

ENCLOSED GABLE END BUILDING

MAXIMUM 30'-0" WIDE X 16'-0" EAVE HEIGHT WITH BOX FRAME / (UP TO) 145 M.P.H. WIND ZONE - 30 P.S.F. SNOW LOAD

FOR:

**N.C. CARPORTS & GARAGES
116 EAST MARKET STREET / ELKIN, NC. 28621**

ISSUE DATE: FEBRUARY 01, 2023



JCMT Associates, LLC

**211 Stone Drive, Pilot Mountain, NC 27041
336-399-6277**

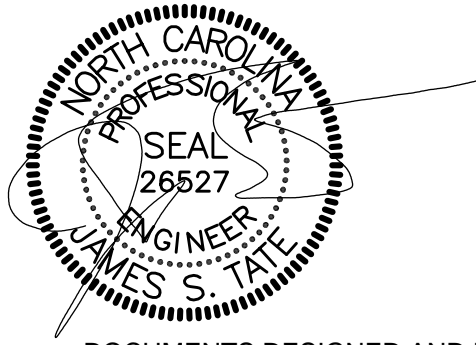

DOCUMENTS DESIGNED AND DRAWN TO MEET THE 2018 NC BUILDING CODE (2015 IBC)

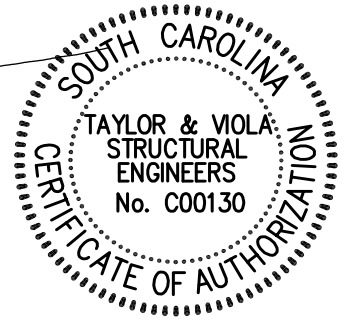
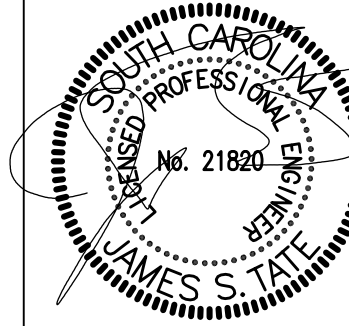

DOCUMENTS DESIGNED AND DRAWN TO MEET THE 2021 SC BUILDING CODE (2021 IBC)

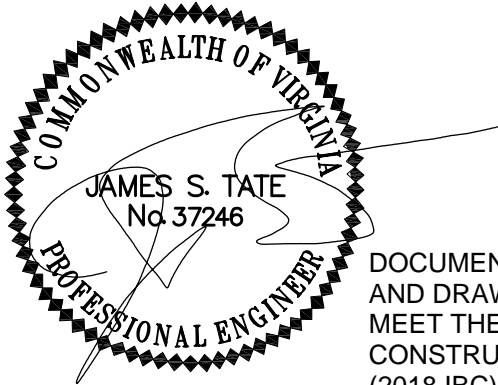

DOCUMENTS DESIGNED AND DRAWN TO MEET THE 2018 VA CONSTRUCTION CODE (2018 IBC)

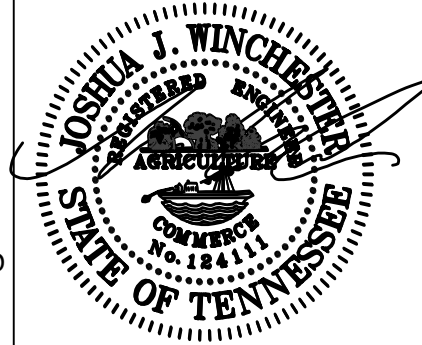

DOCUMENTS DESIGNED AND DRAWN TO MEET THE 2012 IBC



DOCUMENTS DESIGNED AND DRAWN TO MEET THE 2018 IBC



DOCUMENTS DESIGNED AND DRAWN TO MEET THE 2020 BUILDING CODE OF NEW YORK STATE (2018 IBC)

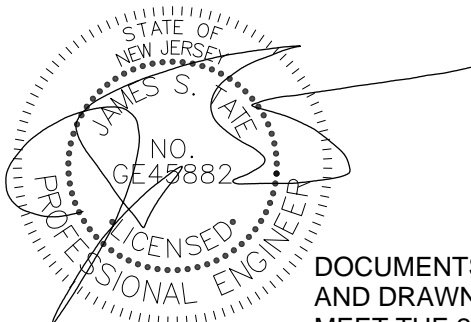

DOCUMENTS DESIGNED AND DRAWN TO MEET THE 20210 BUILDING CODENEW JERSEY EDITION (2021 IBC)

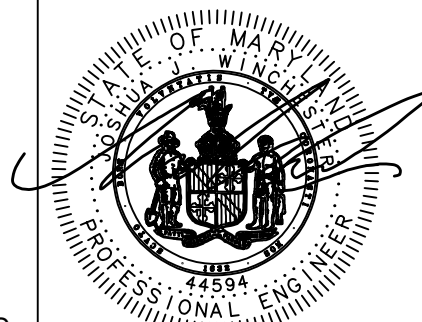

DOCUMENTS DESIGNED AND DRAWN TO MEET THE 2018 IBC

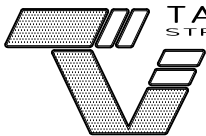

TAYLOR & VIOLA
STRUCTURAL ENGINEERS
P.O.B. 2616 HICKORY NORTH CAROLINA
TELE: 828-328-6331 FAX: 828-322-1801
WWW.TAYLORVIOLA.COM

N . C . CARPORT
& GARAGES

116 EAST MARKET STREET
ELKIN, NORTH CAROLINA 28621

DRAWN BY:
BKS

PROJECT NO:
MISC

DATE:
2023.02.01

SHEET NO:
S1



DOCUMENTS DESIGNED AND DRAWN TO MEET THE 2018 IBC



DOCUMENTS DESIGNED AND DRAWN TO MEET THE 2021 BUILDING CODE OF ALABAMA (2021 IBC)



DOCUMENTS DESIGNED AND DRAWN TO MEET THE 2018 IBC

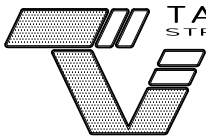

TAYLOR & VIOLA
STRUCTURAL ENGINEERS

P.O.B. 2616 HICKORY NORTH CAROLINA
TELE: 828-328-6331 FAX: 828-322-1801
WWW.TAYLORVIOLA.COM

N.C. CARPORT
& GARAGES

116 EAST MARKET STREET
ELKIN, NORTH CAROLINA 28621

DRAWN BY:
BKS

PROJECT NO:
MISC

DATE:
2023.02.01

SHEET NO:
S1

SHEET INDEX

SHEET NUMBER	SHEET TITLE
S0	SEALED COVER SHEET
S1	P.E. SEALS SHEET
S1A	P.E. SEALS SHEET
S2	DRAWING INDEX
S3	GENERAL NOTES AND SPECIFICATIONS
S4	SIDE AND END ELEVATIONS
S5	TYPICAL RAFTER / COLUMN FRAME SECTIONS
S5A	TYPICAL RAFTER / COLUMN FRAME SECTIONS
S5B	TYPICAL RAFTER / COLUMN FRAME AND SIDE FRAMING SECTION
S6	COLUMN CONNECTION DETAILS (LACED COLUMN)
S6A	COLUMN CONNECTION DETAILS (DOUBLE AND SINGLE COLUMN)
S6B	COLUMN CONNECTION DETAILS (LACED COLUMN)
S6C	COLUMN CONNECTION DETAILS (DOUBLE AND SINGLE COLUMN)
S7	BASE RAIL ANCHORAGE
S7A	BASE RAIL ANCHORAGE
S8	BASE RAIL ANCHORAGE
S9	TYPICAL END WALL OPENINGS FRAMING SECTIONS
S9A	TYPICAL SIDE WALL OPENINGS FRAMING SECTIONS
S10	CONNECTION DETAILS
S11	CONNECTION DETAILS
S12	CONNECTION DETAILS
S13	CONNECTION DETAILS
S14	CONNECTION DETAILS
S15	LEAN-TO OPTIONS
S15A	LEAN-TO CONNECTION DETAILS
S15B	LEAN-TO CONNECTION DETAILS
S15C	LEAN-TO CONNECTION DETAILS
S16	VERTICAL ROOF / SIDING OPTION END AND SIDE ELEVATION
S16A	VERTICAL ROOF / SIDING OPTION END SECTION
S16B	VERTICAL ROOF / SIDING OPTION SIDE SECTION
S17	SIDE WALL HEADER OPTIONS
S17A	END WALL HEADER OPTIONS



N . C . C A R P O R T
& G A R A G E S

116 EAST MARKET STREET
ELKIN, NORTH CAROLINA 28621

DRAWN BY:
BKS

PROJECT NO:
MISC

DATE:
2023.02.01

SHEET NO:
S2

DESIGN LOADS:

IMPORTANCE FACTORS	WIND	(1w)	1.00	
	SNOW	(1s)	1.00	
	SEISMIC	(1e)	1.00	
DEAD LOADS	ROOF	13	PSF	
	ROOF COLLATERAL	0	PSF	
LIVE LOADS	ROOF	20	PSF	
GROUND SNOW LOAD:		30	PSF	
GROUND LOAD:	BASIC WIND SPEED	V 145	mph (ASCE 7-10)	* DRIFT LOAD HAS NOT BEEN CALCULATED
	EXPOSURE CATAGORY	B		

SEISMIC DESIGN CATAGORY A

COMPLIANCE WITH SECTION 1616.4? NO YES

PROVIDE THE FOLLOWING SEISMIC DESIGN PARAMETERS:

OCCUPANCY CATEGORY I

SPECTRAL RESPONSE ACCELERATION Ss 20.5 %g S1 8.8 %g

SITE CLASSIFICATION D FIELD TEST PRESUMPTIVE HISTORICAL DATA

BASIC STRUCTURAL SYSTEM (CHECK ONE)

<input type="checkbox"/>	BEARING WALL	<input type="checkbox"/>	DUAL W/ SPECTRAL MOMENT FRAME
<input checked="" type="checkbox"/>	BUILDING FRAME	<input type="checkbox"/>	DUAL W/ INTERMEDIATE R/C OR SPECIAL STEEL
<input type="checkbox"/>	MOMENT FRAME	<input type="checkbox"/>	INVERTED PENDULUM

ANALYSIS PROCEDURE SIMPLIFIED EQUIVALANT LATERAL FORCE MODAL

LATERAL DESIGN CONTROL? EARTHQUAKE WIND

SOIL BEARING CAPACITIES:

PRESUMPTIVE BEARING CAPACITIES: 2,000 PSF

GENERAL NOTES:

1. MAX FRAME SPACING SHALL BE 60"oc UNLESS NOTED OTHERWISE.
2. MAX. END-WALL COLUMN SPACING SHALL BE 60"oc UNLESS NOTED OTHERWISE.
3. TUBE MATERIAL SHALL BE 2-1/2" x 2-1/2" x 14 GA. 50 KSI MIN. UNLESS NOTED OTHERWISE.
4. ALL FASTENERS SHALL BE #12 SELF TAPPING AT 9"o.c. UNLESS NOTED OTHERWISE.
5. 2,000 PSF ASSUMED BEARING CAPACITY UNLESS NOTED OTHERWISE.



N . C . C A R P O R T
& G A R A G E S

116 EAST MARKET STREET
ELKIN, NORTH CAROLINA 28621

DRAWN BY:
BKS

PROJECT NO:
MISC

DATE:
2023.02.01

SHEET NO:
S3

BOX EVE FRAME RAFTER STURCTURE

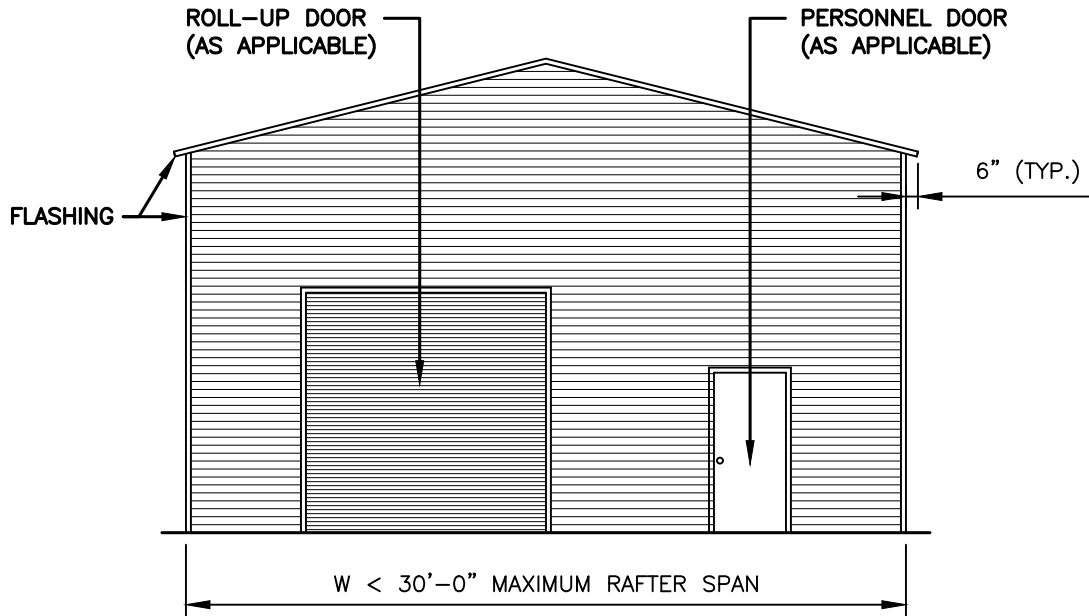

TYPICAL END ELEVATION

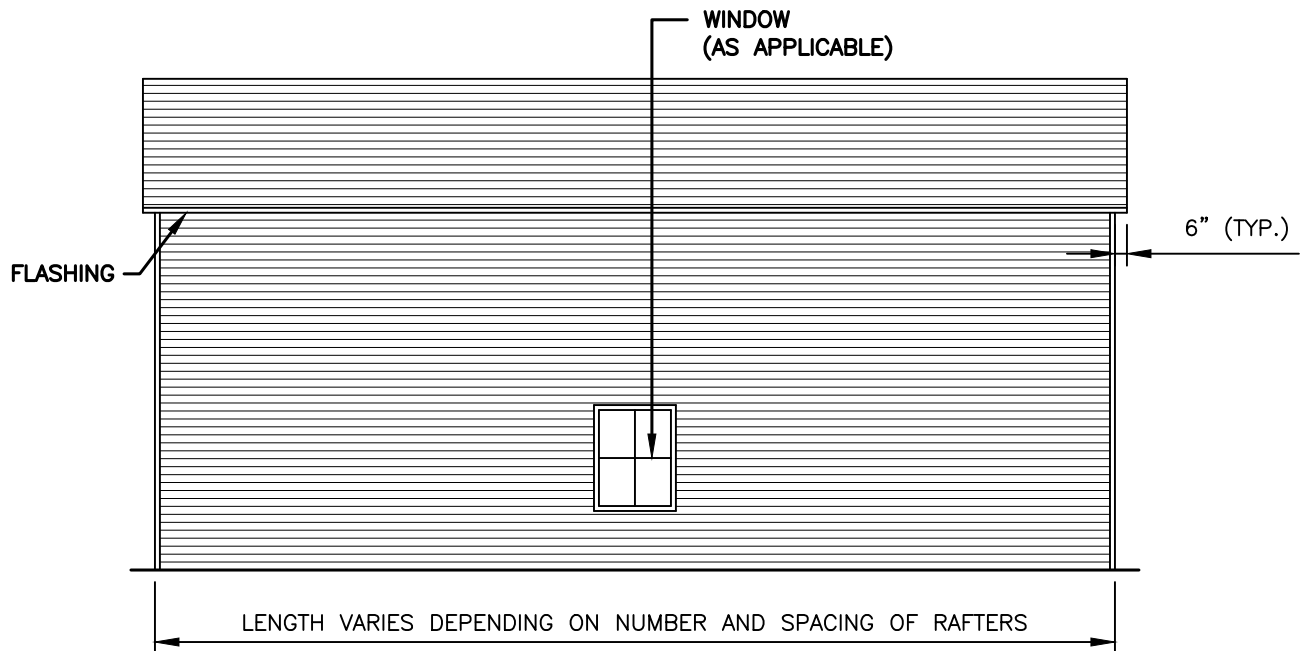

TYPICAL SIDE ELEVATION

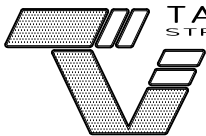

TAYLOR & VIOLA
STRUCTURAL ENGINEERS

P.O.B. 2616 HICKORY NORTH CAROLINA
TELE: 828-328-6331 FAX: 828-322-1801
WWW.TAYLORVIOLA.COM

N . C . CARPORT
& GARAGES

116 EAST MARKET STREET
ELKIN, NORTH CAROLINA 28621

DRAWN BY:
BKS

DATE:
2023.02.01

PROJECT NO:
MISC

SHEET NO:
S4

'U' BRACE TRUSS TIE - NOTE:
 6'-0" BRACE FOR 21'-24' BUILDING WIDTH
 20' TUBE TRUSS TIE (AS SHOWN) FOR 25'-30'

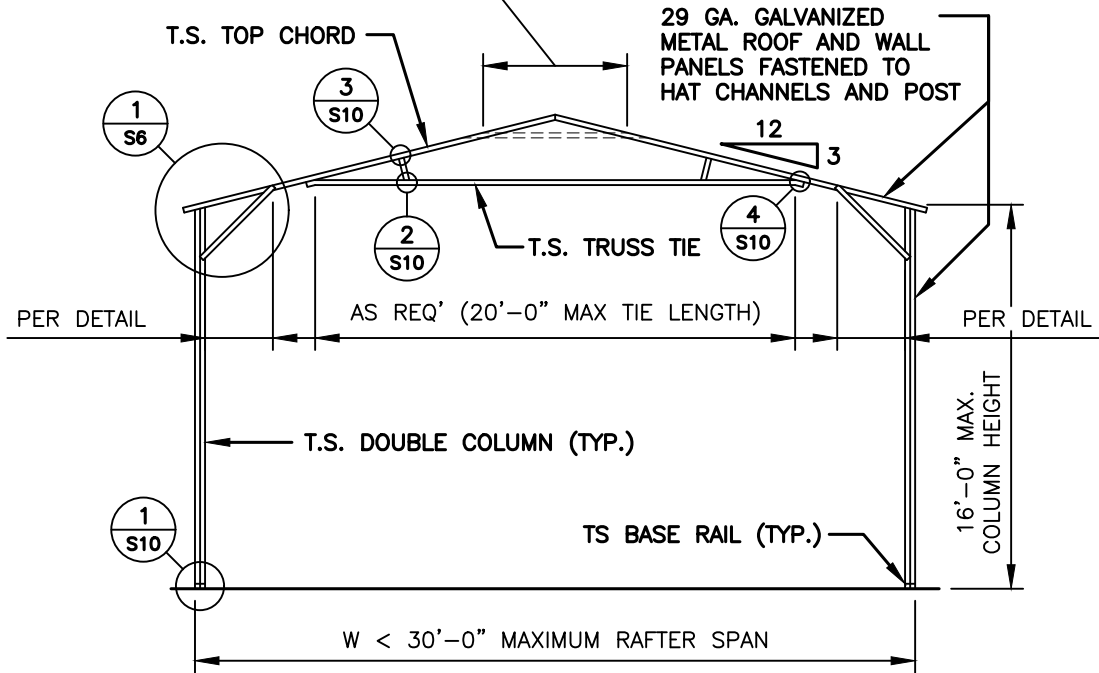

TYPICAL RAFTER / COLUMN FRAME SECTION

'U' BRACE TRUSS TIE - NOTE:
 6'-0" BRACE FOR 21'-24' BUILDING WIDTH
 20' TUBE TRUSS TIE (AS SHOWN) FOR 25'-30'

NOTE:
 H.S.S. 2-1/2"x2-1/2"x14ga. OR 2-1/4"x2-1/4"x14ga.
 MATERIAL MAY BE USED FOR TRUSS METAL.

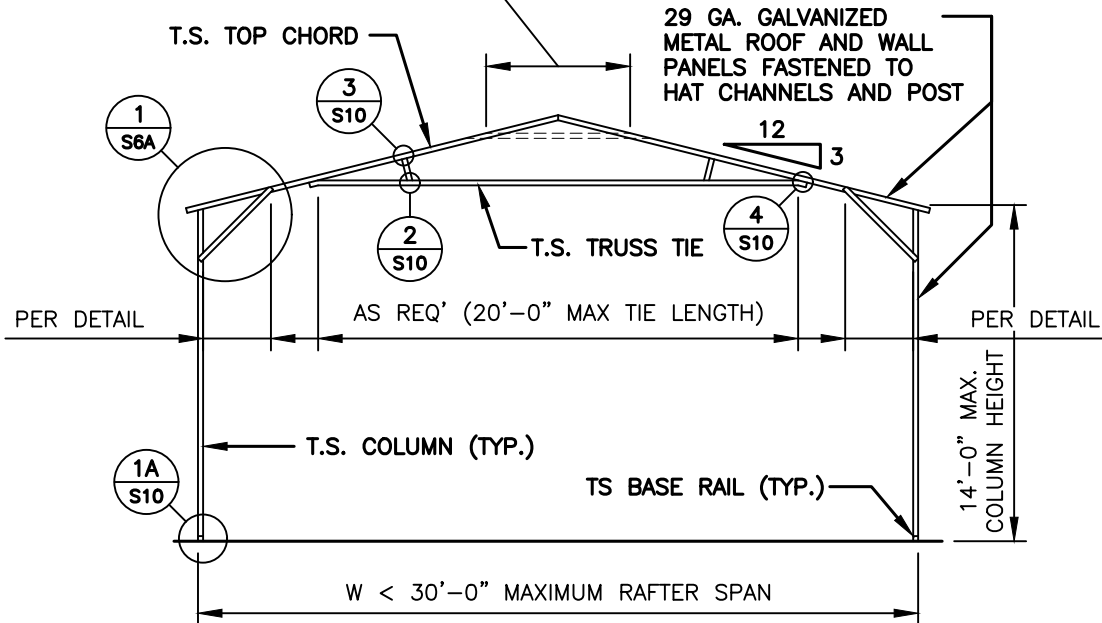

TYPICAL RAFTER / COLUMN FRAME SECTION



N.C. CARPORT
 & GARAGES

116 EAST MARKET STREET
 ELKIN, NORTH CAROLINA 28621

DRAWN BY:
 BKS

PROJECT NO:
 MISC

DATE:
 2023.02.01

SHEET NO:
S5

'U' BRACE TRUSS TIE - NOTE:
 6'-0" BRACE FOR 21'-24' BUILDING WIDTH
 20' TUBE TRUSS TIE (AS SHOWN) FOR 25'-30'

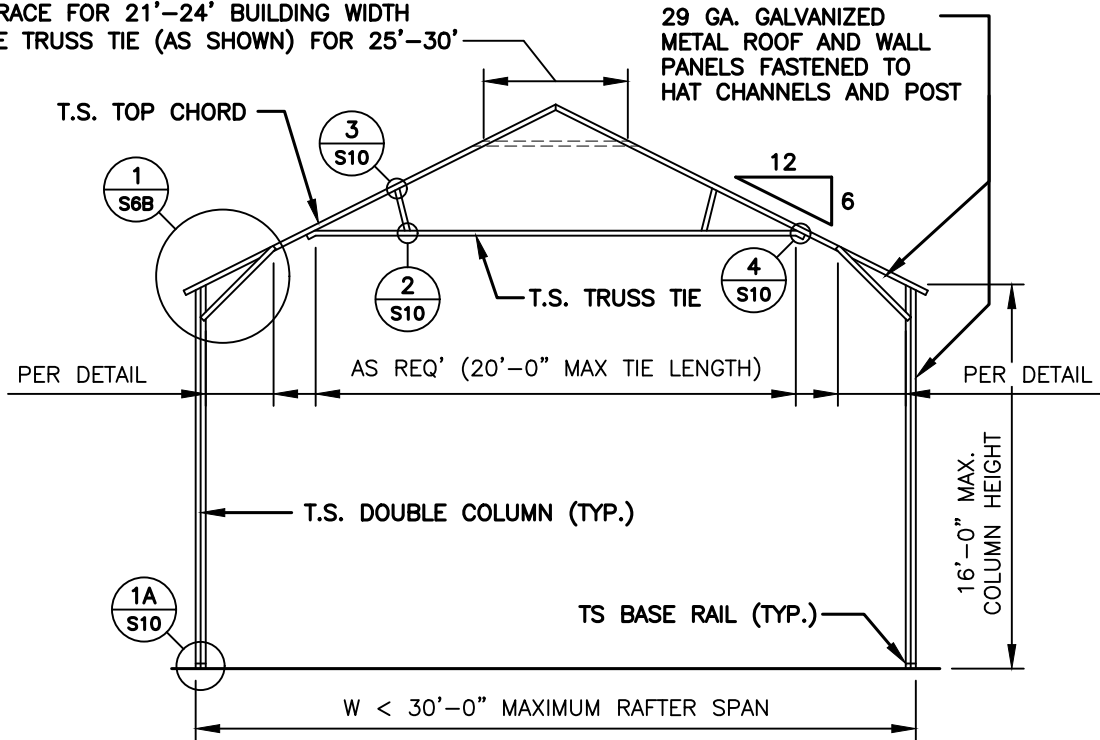

TYPICAL RAFTER / COLUMN FRAME SECTION

'U' BRACE TRUSS TIE - NOTE:
 6'-0" BRACE FOR 21'-24' BUILDING WIDTH
 20' TUBE TRUSS TIE (AS SHOWN) FOR 25'-30'

NOTE:
 H.S.S. 2-1/2"x2-1/2"x14ga. OR 2-1/4"x2-1/4"x14ga.
 MATERIAL MAY BE USED FOR TRUSS METAL.

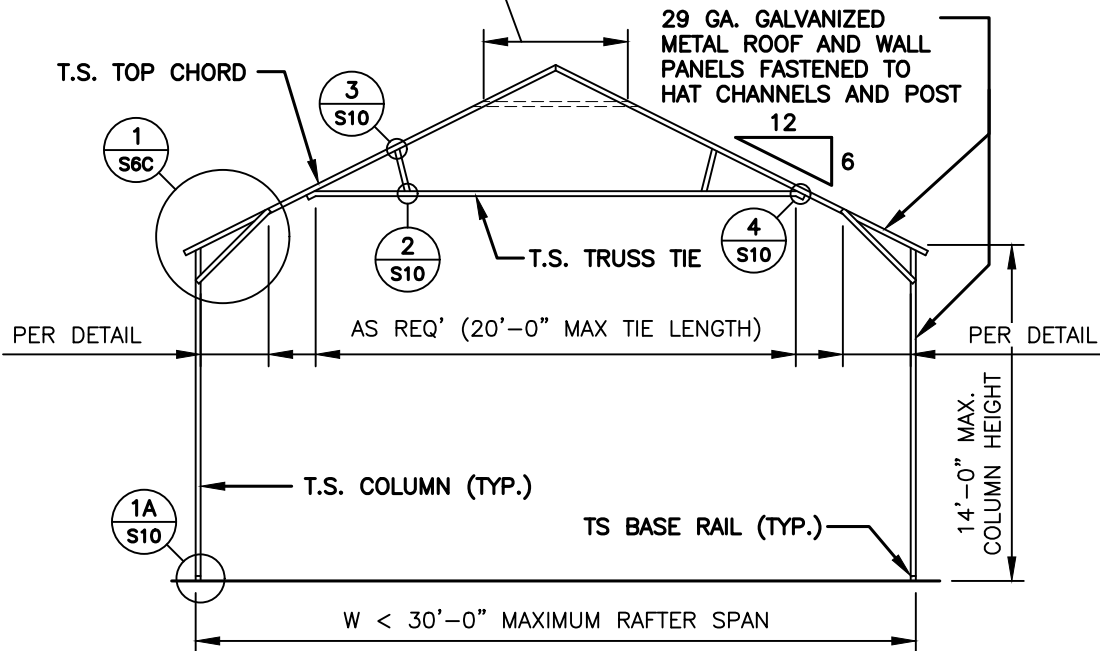

TYPICAL RAFTER / COLUMN FRAME SECTION

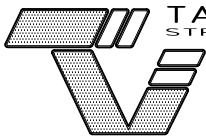

TAYLOR & VIOLA
 STRUCTURAL ENGINEERS
 P.O.B. 2616 HICKORY NORTH CAROLINA
 TELE: 828-328-6331 FAX: 828-322-1801
 WWW.TAYLORVIOLA.COM

**N.C. CARPORT
 & GARAGES**

116 EAST MARKET STREET
 ELKIN, NORTH CAROLINA 28621

DRAWN BY:
 BKS

PROJECT NO:
 MISC

DATE:
 2023.02.01

SHEET NO:
S5A

NOTE:
 H.S.S. 2-1/2"x2-1/2"x14ga. OR
 2-1/4"x2-1/4"x14ga. MATERIAL
 MAY BE USED FOR TRUSS METAL.

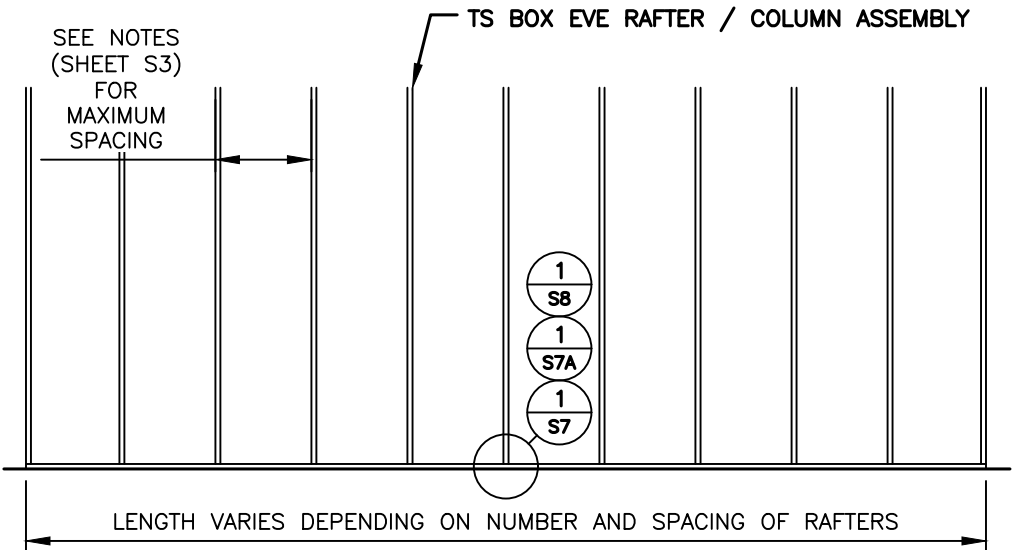

TYPICAL RAFTER / COLUMN SIDE FRAME SECTION



TAYLOR & VIOLA
 STRUCTURAL ENGINEERS
 P.O.B. 2616 HICKORY NORTH CAROLINA
 TELE: 828-328-6331 FAX: 828-322-1801
 WWW.TAYLORVIOLA.COM

N.C. CARPORT
 & GARAGES
 116 EAST MARKET STREET
 ELKIN, NORTH CAROLINA 28621

DRAWN BY: BKS	PROJECT NO: MISC
DATE: 2023.02.01	SHEET NO: S5B

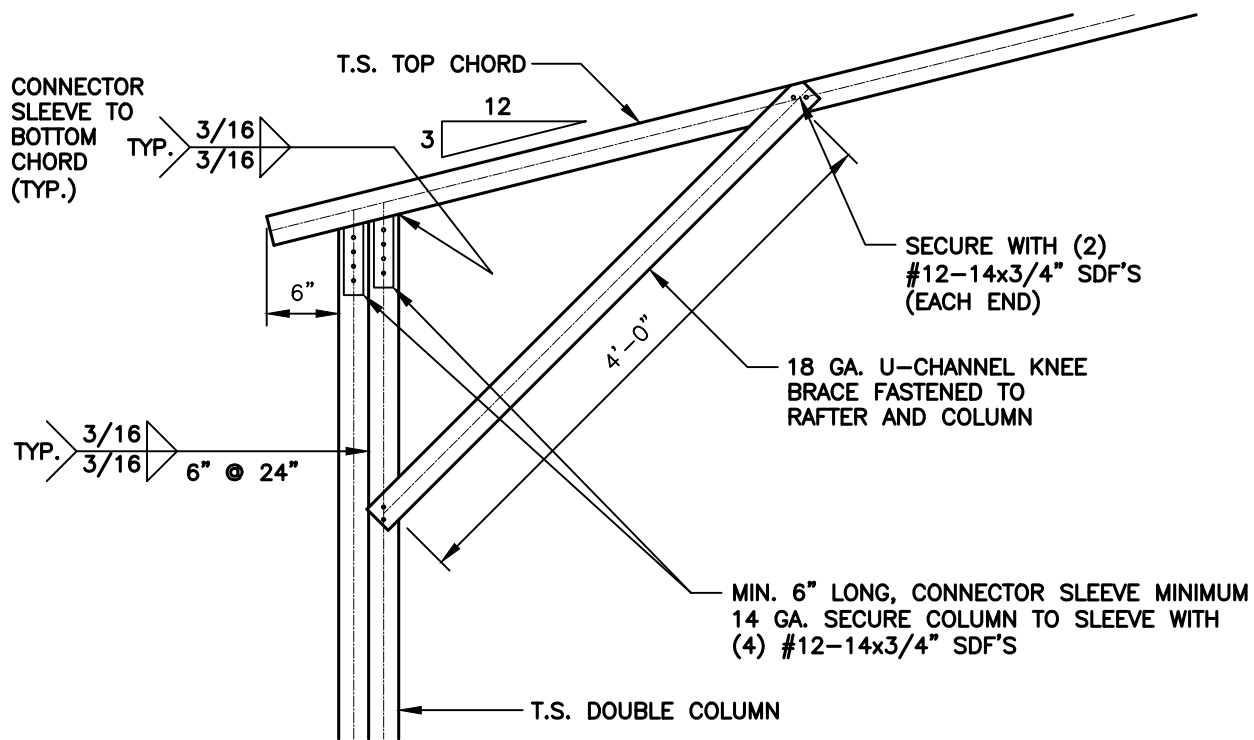

1 BOX EAVE / CORNER POST CONNECTION DETAIL FOR HEIGHTS 14'-1" < TO <16'-0"

S6 SCALE: 3/4" = 1'-0"

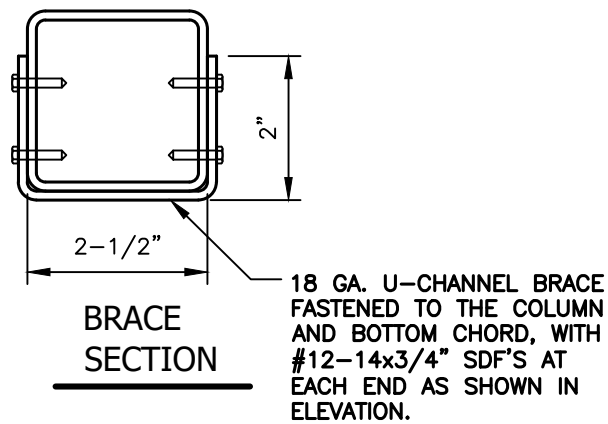

TAYLOR & VIOLA
STRUCTURAL ENGINEERS

P.O.B. 2616 HICKORY NORTH CAROLINA
TELE: 828-328-6331 FAX: 828-322-1801
WWW.TAYLORVIOLA.COM

N.C. CARPORT
& GARAGES

116 EAST MARKET STREET
ELKIN, NORTH CAROLINA 28621

DRAWN BY:
BKS

PROJECT NO:
MISC

DATE:
2023.02.01

SHEET NO:
S6

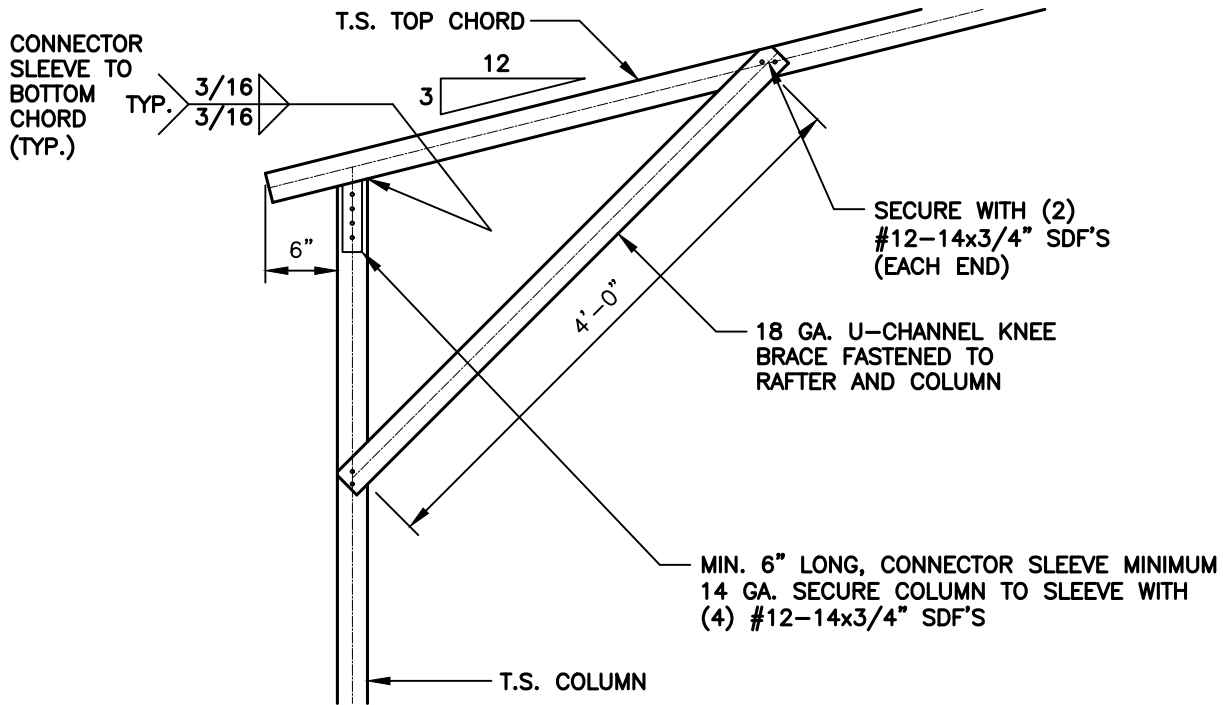

1 BOX EAVE / CORNER POST CONNECTION DETAIL FOR HEIGHTS < 14'-0"

S6A SCALE: 3/4" = 1'-0"

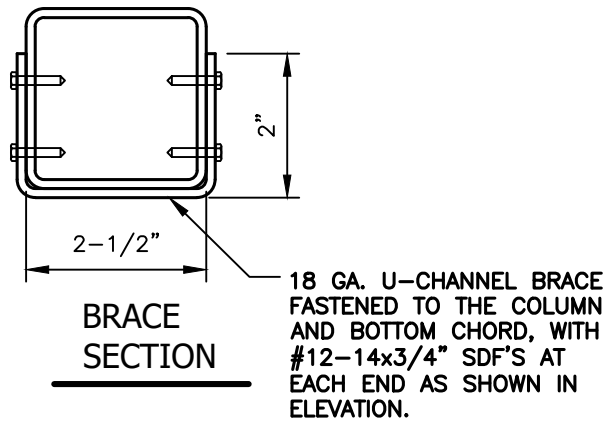

N.C. CARPORT
& GARAGES

116 EAST MARKET STREET
ELKIN, NORTH CAROLINA 28621

DRAWN BY:
BKS

PROJECT NO:
MISC

DATE:
2023.02.01

SHEET NO:
S6A

CONNECTOR SLEEVE TO BOTTOM CHORD (TYP.)

TYP. $\frac{3}{16}$ / $\frac{3}{16}$

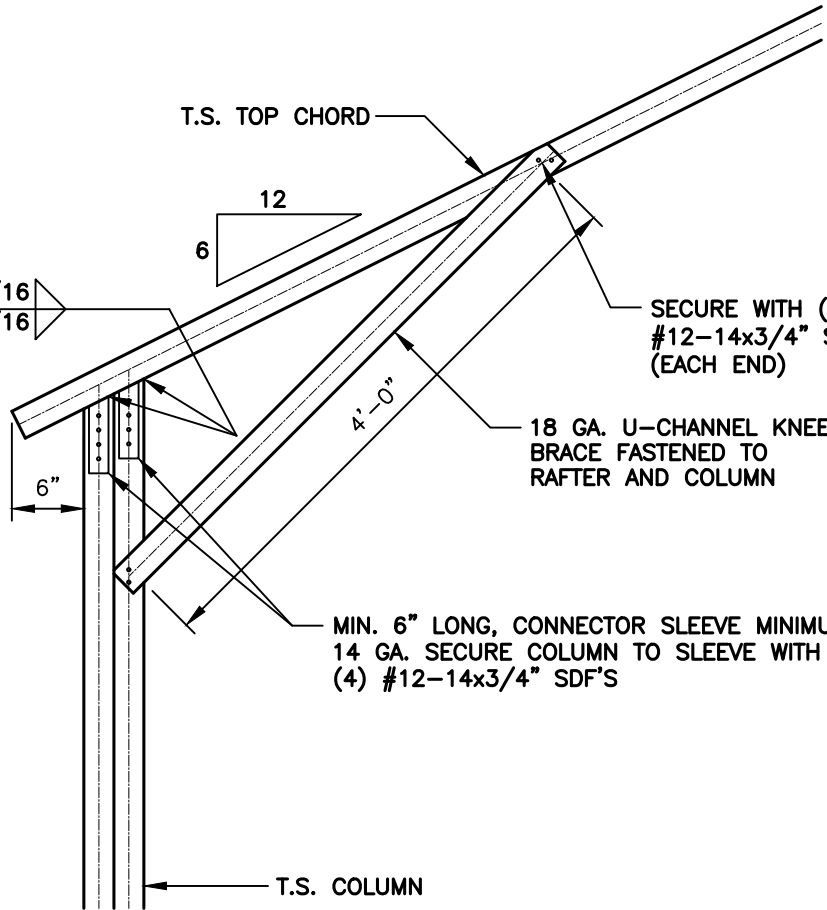

SECURE WITH (2) #12-14x3/4" SDF'S (EACH END)

18 GA. U-CHANNEL KNEE BRACE FASTENED TO RAFTER AND COLUMN

MIN. 6" LONG, CONNECTOR SLEEVE MINIMUM 14 GA. SECURE COLUMN TO SLEEVE WITH (4) #12-14x3/4" SDF'S

T.S. COLUMN

1
S6C

BOX EAVE / CORNER POST CONNECTION DETAIL FOR HEIGHTS 14'-1" < TO <16'-0"

SCALE: 3/4" = 1'-0"

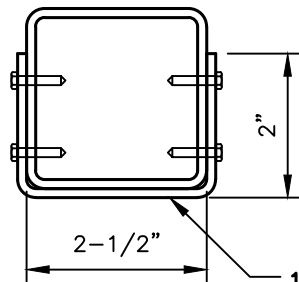

BRACE SECTION

18 GA. U-CHANNEL BRACE FASTENED TO THE COLUMN AND BOTTOM CHORD, WITH #12-14x3/4" SDF'S AT EACH END AS SHOWN IN ELEVATION.



TAYLOR & VIOLA
STRUCTURAL ENGINEERS

P.O.B. 2616 HICKORY NORTH CAROLINA
TELE: 828-328-6331 FAX: 828-322-1801
WWW.TAYLORVIOLA.COM

N.C. CARPORT
& GARAGES

116 EAST MARKET STREET
ELKIN, NORTH CAROLINA 28621

DRAWN BY:
BKS

PROJECT NO:
MISC

DATE:
2023.02.01

SHEET NO:
S6B

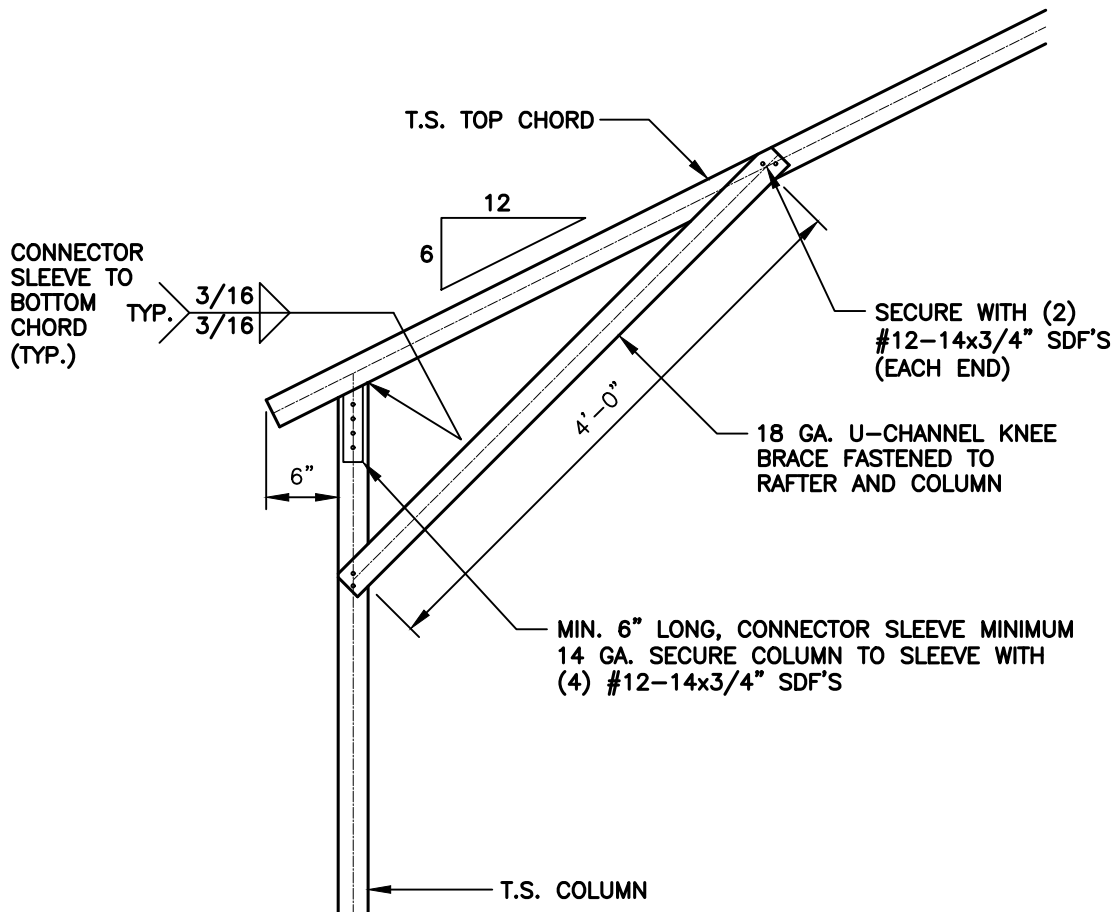

1 BOX EAVE / CORNER POST CONNECTION DETAIL FOR HEIGHTS < 14'-0"

S6C

SCALE: 3/4" = 1'-0"

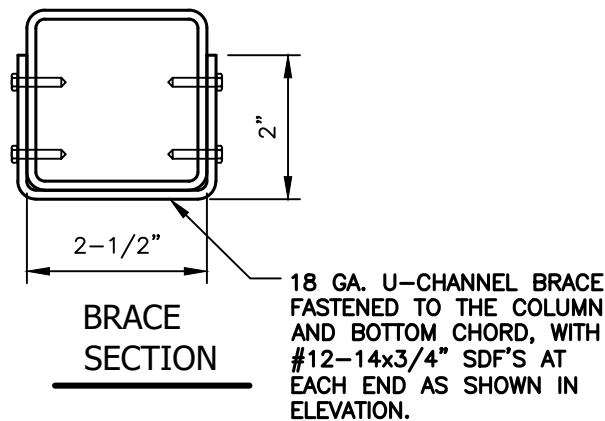

TAYLOR & VIOLA
STRUCTURAL ENGINEERS

P.O.B. 2616 HICKORY NORTH CAROLINA
TELE: 828-328-6331 FAX: 828-322-1801
WWW.TAYLORVIOLA.COM

N.C. CARPORT
& GARAGES

116 EAST MARKET STREET
ELKIN, NORTH CAROLINA 28621

DRAWN BY:
BKS

PROJECT NO:
MISC

DATE:
2023.02.01

SHEET NO:
S6C

CONCRETE BASE RAIL ANCHORAGE

INSTALL (1) 1/2"x6 1/2"
EXPANSION ANCHOR THROUGH BASE
RAIL WITHIN 6" OF EACH COLUMN.
(ALSO APPLICABLE TO END WALLS)

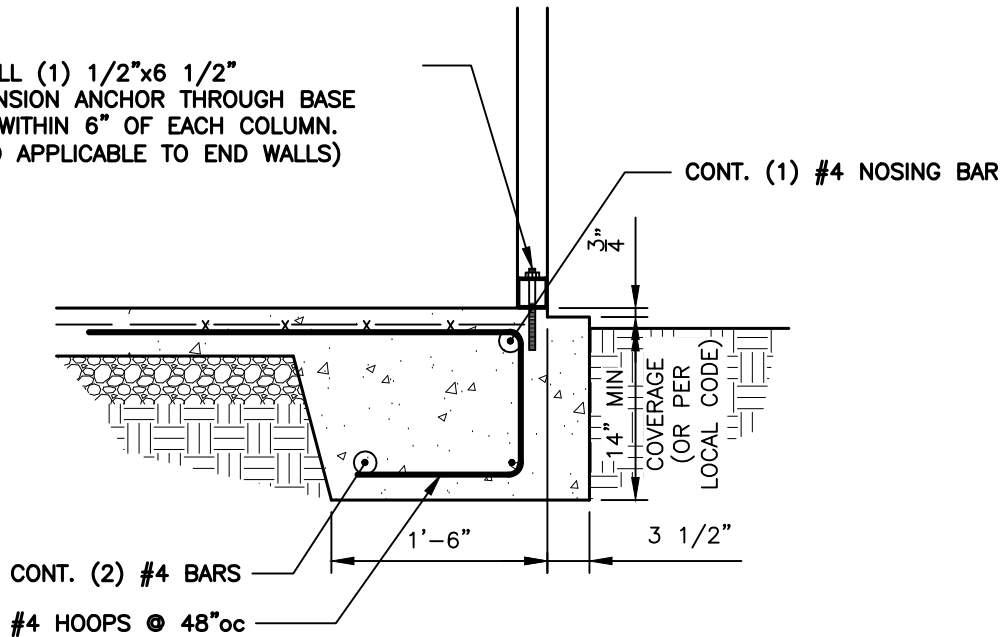

BASE RAIL ANCHORAGE DETAIL

SCALE: 3/4" = 1'-0"

GENERAL NOTES:

ALL CONCRETE MONOLITHIC SLAB DESIGN BASED ON MINIMUM SOIL BEARING CAPACITY OF 2,000 PSF

CONCRETE:

CONCRETE SHALL HAVE A MINIMUM SPECIFIED COMPRESSIVE STRENGTH OF 3,000 PSI AT 28 DAYS

COVER OVER REINFORCING STEEL:

FOR FOUNDATIONS, MINIMUM CONCRETE COVER OVER REINFORCING BARS SHALL BE PER ACI-318:

3" IN FOUNDATIONS WHERE THE CONCRETE IS CAST AGAINST AND PERMANENTLY IN CONTACT WITH THE EARTH OR EXPOSED TO THE EARTH AND WEATHER AND 1-1/2" ELSEWHERE.

REINFORCING STEEL:

THE TURNDOWN REINFORCING STEEL SHALL BE ASTM A615 GRADE 60. THE SLAB REINFORCEMENT SHALL BE WELDED WIRE FABRIC MEETING ASTM A185 OR FIBERGLASS FIBER REINFORCEMENT.

REINFORCEMENT MAT BE BENT IN THE SHOP OF THE FIELD PROVIDED:

1. REINFORCEMENT IS BENT COLD.
2. THE DIAMETER OF THE BEND, MEASURED ON THE INSIDE OF THE BAR, IS NOT LESS THAN SIX-BAR DIAMETERS.
3. REINFORCEMENT PARTIALLY EMBEDDED IN CONCRETE SHALL NOT BE FIELD BENT.

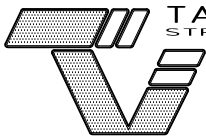

TAYLOR & VIOLA
STRUCTURAL ENGINEERS

P.O.B. 2616 HICKORY NORTH CAROLINA
TELE: 828-328-6331 FAX: 828-322-1801
WWW.TAYLORVIOLA.COM

N . C . C A R P O R T
& G A R A G E S

116 EAST MARKET STREET
ELKIN, NORTH CAROLINA 28621

DRAWN BY:
BKS

PROJECT NO:
MISC

DATE:
2023.02.01

SHEET NO:
S7

CONCRETE BASE RAIL ANCHORAGE

INSTALL (1) 1/2"x6 1/2"
EXPANSION ANCHOR THROUGH BASE
RAIL WITHIN 6" OF EACH COLUMN.
(ALSO APPLICABLE TO END WALLS)

CONT. (1) #4 NOSING BAR

INSTALL (1) 1/2"x6 1/2"
EXPANSION ANCHOR
THROUGH BASE RAIL WITHIN
6" OF EACH COLUMN. (ALSO
APPLICABLE TO END WALLS)

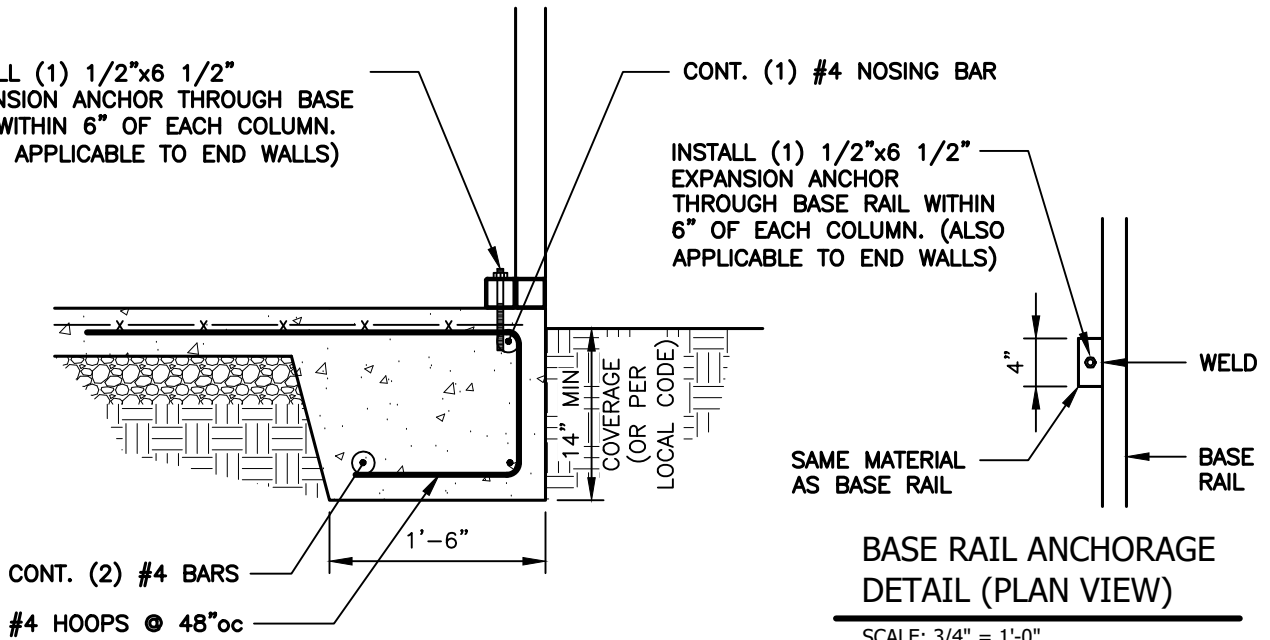

**BASE RAIL ANCHORAGE
DETAIL (PLAN VIEW)**

SCALE: 3/4" = 1'-0"



BASE RAIL ANCHORAGE DETAIL

SCALE: 3/4" = 1'-0"

GENERAL NOTES:

ALL CONCRETE MONOLITHIC SLAB DESIGN BASED ON MINIMUM SOIL BEARING CAPACITY OF 2,000 PSF

CONCRETE:

CONCRETE SHALL HAVE A MINIMUM SPECIFIED COMPRESSIVE STRENGTH OF 3,000 PSI AT 28 DAYS

COVER OVER REINFORCING STEEL:

FOR FOUNDATIONS, MINIMUM CONCRETE COVER OVER REINFORCING BARS SHALL BE PER ACI-318:

3" IN FOUNDATIONS WHERE THE CONCRETE IS CAST AGAINST AND PERMANENTLY IN CONTACT WITH THE EARTH OR EXPOSED TO THE EARTH AND WEATHER AND 1-1/2" ELSEWHERE.

REINFORCING STEEL:

THE TURNDOWN REINFORCING STEEL SHALL BE ASTM A615 GRADE 60. THE SLAB REINFORCEMENT SHALL BE WELDED WIRE FABRIC MEETING ASTM A185 OR FIBERGLASS FIBER REINFORCEMENT.

REINFORCEMENT MAT BE BENT IN THE SHOP OF THE FIELD PROVIDED:

1. REINFORCEMENT IS BENT COLD.
2. THE DIAMETER OF THE BEND, MEASURED ON THE INSIDE OF THE BAR, IS NOT LESS THAN SIX-BAR DIAMETERS.
3. REINFORCEMENT PARTIALLY EMBEDDED IN CONCRETE SHALL NOT BE FIELD BENT.

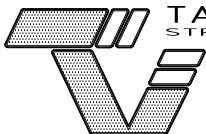

TAYLOR & VIOLA
STRUCTURAL ENGINEERS

P.O.B. 2616 HICKORY NORTH CAROLINA
TELE: 828-328-6331 FAX: 828-322-1801
WWW.TAYLORVIOLA.COM

N . C . C A R P O R T
& G A R A G E S

116 EAST MARKET STREET
ELKIN, NORTH CAROLINA 28621

DRAWN BY:
BKS

PROJECT NO:
MISC

DATE:
2023.02.01

SHEET NO:
S7A

SOIL NAIL BASE RAIL ANCHORAGE

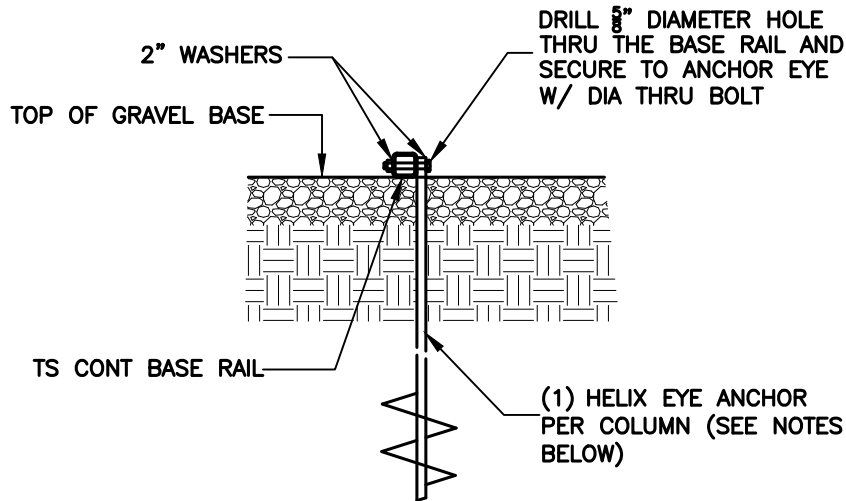

1
S8
BASE RAIL ANCHORAGE DETAIL
 SCALE: 3/4" = 1'-0"

HELIX EMBEDMENT INFORMATION:

FOR VERY DENSE OR CEMENTED SANDS, COARSE GRAVEL, COBBLES, CALICHE, PRELOADED SILTS AND CLAYS, USE MIN (2) 4" HELICES WITH MINIMUM 30" EMBEDMENT OR SINGLE 6" HELIX WITH 50" EMBEDMENT

FOR CORAL, USE MIN (2) 4" HELICES WITH MINIMUM 30" EMBEDMENT OR SINGLE 6" HELIX WITH 50" EMBEDMENT

FOR MED DENSE COARSE SANDS, SANDY GRAVEL, VERY STIFF SILTS, AND CLAYS, USE MIN (2) 4" HELICES WITH MINIMUM 30" EMBEDMENT OR SINGLE 6" HELIX WITH 50" EMBEDMENT

FOR LOOSE TO MEDIUM DENSE SANDS, FIRM TO STIFF CLAYS AND SILTS, USE MIN (2) 6" HELICES WITH MINIMUM 50" EMBEDMENT

FOR VERY LOOSE TO MEDIUM DENSE SANDS, FIRM TO STIFFER CLAYS AND SILTS AND ALLUVIAL FILL, USE MIN (2) 8" HELICES WITH MINIMUM 60" EMBEDMENT

 <p>TAYLOR & VIOLA STRUCTURAL ENGINEERS</p> <p><small>P.O.B. 2616 HICKORY NORTH CAROLINA TELE: 828-328-6331 FAX: 828-322-1801 WWW.TAYLORVIOLA.COM</small></p>	<p>N.C. CARPORT & GARAGES</p> <p>116 EAST MARKET STREET ELKIN, NORTH CAROLINA 28621</p>	DRAWN BY: BKS	PROJECT NO: MISC
		DATE: 2023.02.01	SHEET NO: S8

BOX EVE RAFTER END WALL OPENINGS

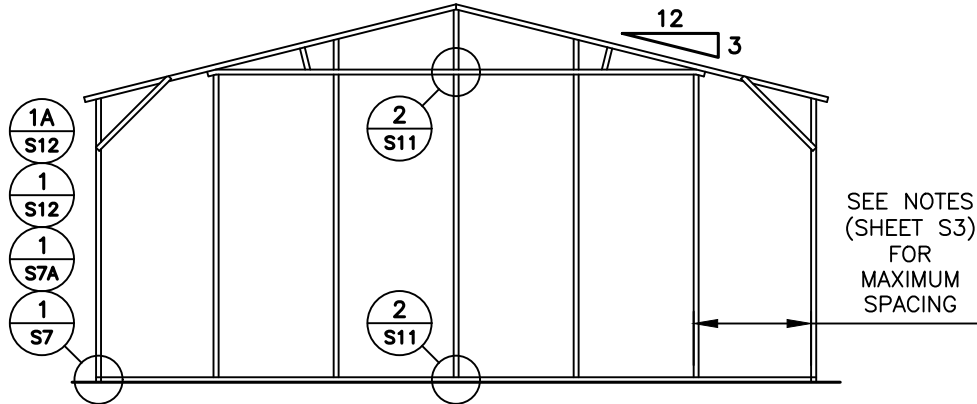

TYPICAL BOX EVE RAFTER / END WALL COLUMN FRAME SECTION

NOTE:
 ROLL UP DOORS SHALL
 HAVE ONE JAMB EACH
 SIDE + ONE FRAME
 COLUMN BETWEEN OR SITE
 SPECIFIC SHALL BE REQ'D.

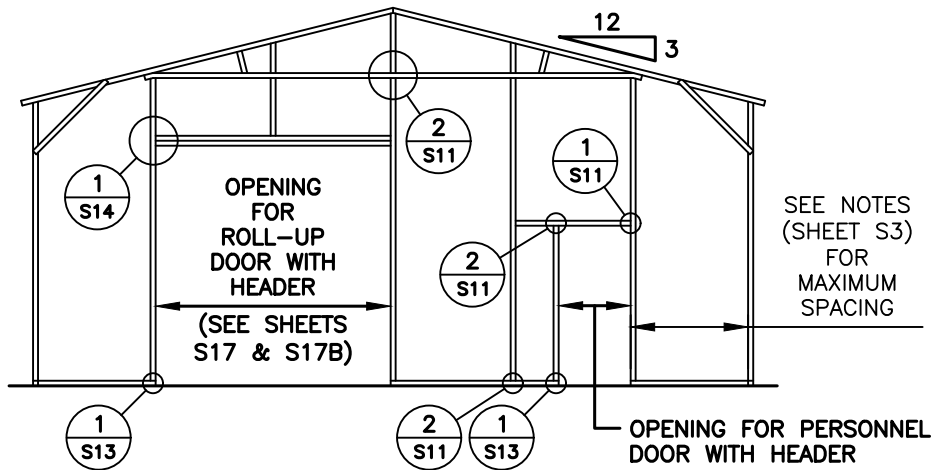

TYPICAL BOX EVE RAFTER END WALL OPENINGS FRAMING SECTION

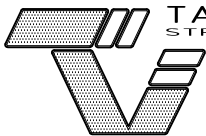

TAYLOR & VIOLA
 STRUCTURAL ENGINEERS

P.O.B. 2616 HICKORY NORTH CAROLINA
 TELE: 828-328-6331 FAX: 828-322-1801
 WWW.TAYLORVIOLA.COM

N.C. CARPORT
 & GARAGES

116 EAST MARKET STREET
 ELKIN, NORTH CAROLINA 28621

DRAWN BY:
 BKS

PROJECT NO:
 MISC

DATE:
 2023.02.01

SHEET NO:
S9

BOX EVE RAFTER END WALL AND SIDE WALL OPENINGS

NOTE:
 ROLL UP DOORS SHALL HAVE ONE JAMB
 EACH SIDE + ONE FRAME COLUMN BETWEEN
 OR SITE SPECIFIC SHALL BE REQ'D.

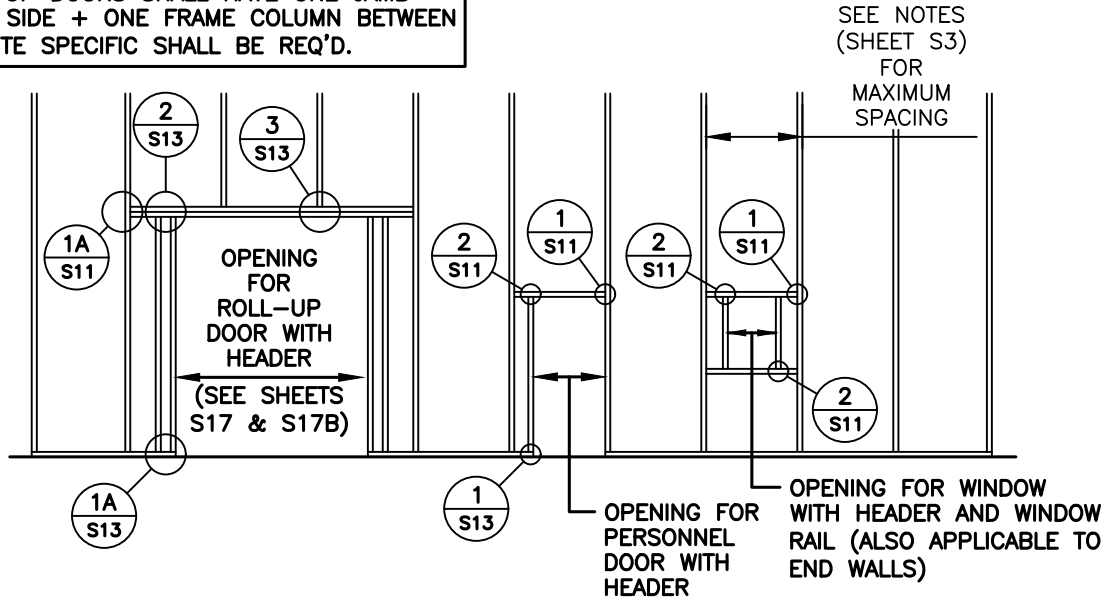

TYPICAL END WALL OPENING FRAMING SECTION

NOTE:
 ROLL UP DOORS SHALL HAVE ONE JAMB
 EACH SIDE + ONE FRAME COLUMN BETWEEN
 OR SITE SPECIFIC SHALL BE REQ'D.

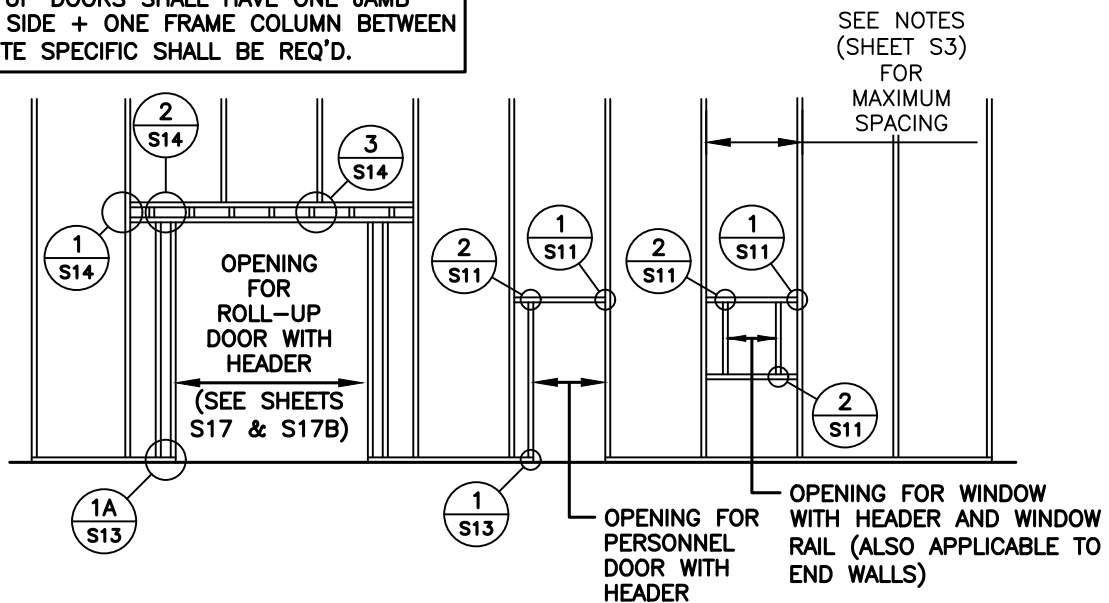

TYPICAL SIDE WALL OPENING FRAMING SECTION

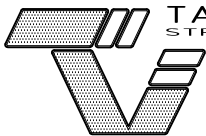

TAYLOR & VIOLA
 STRUCTURAL ENGINEERS

P.O.B. 2616 HICKORY NORTH CAROLINA
 TELE: 828-328-6331 FAX: 828-322-1801
 WWW.TAYLORVIOLA.COM

N . C . CARPORT
 & GARAGES

116 EAST MARKET STREET
 ELKIN, NORTH CAROLINA 28621

DRAWN BY:
 BKS

PROJECT NO:
 MISC

DATE:
 2023.02.01

SHEET NO:
S9A

CONNECTION DETAILS

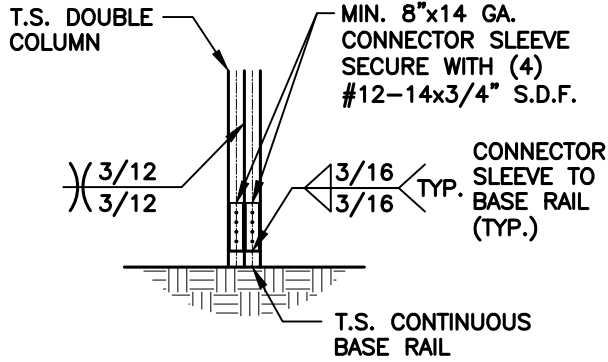

1
POST / BASE RAIL
CONNECTION DETAIL

S10 SCALE: 1/2" = 1'-0"

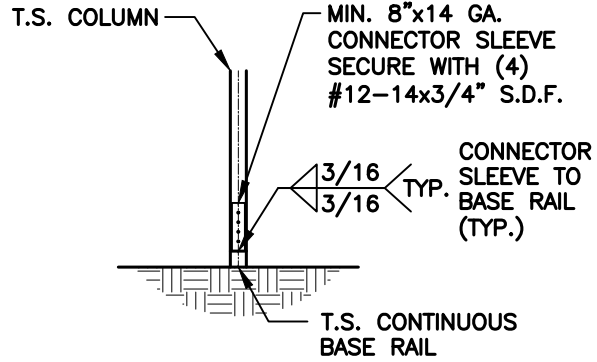

1A
POST / BASE RAIL
CONNECTION DETAIL

S10 SCALE: 1/2" = 1'-0"

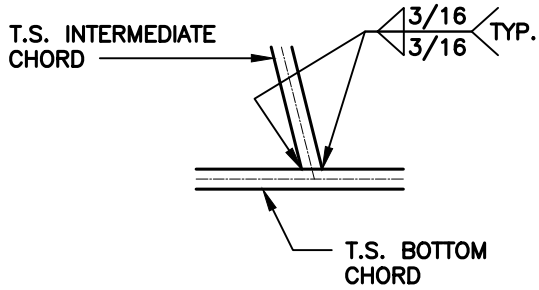

2
INTERMEDIATE CHORD
TO BOTTOM CHORD
CONNECTION DETAIL

S10 SCALE: 1/2" = 1'-0"

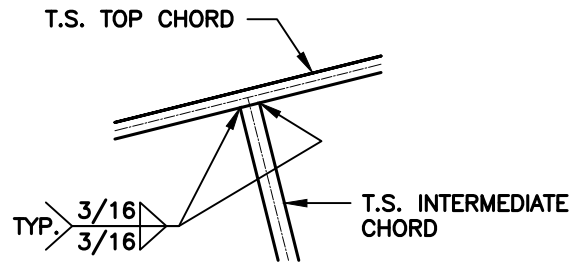

3
INTERMEDIATE CHORD TO TOP
CHORD CONNECTION DETAIL

S10 SCALE: 1/2" = 1'-0"

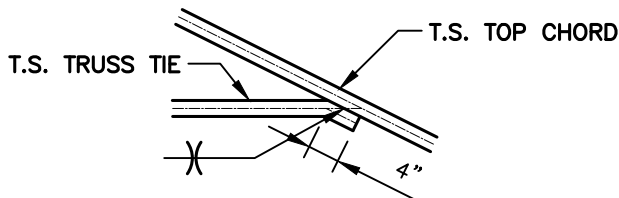

4
TRUSS TIE
CONNECTION DETAIL

S10 SCALE: 1/2" = 1'-0"



N . C . CARPORT
& GARAGES

116 EAST MARKET STREET
ELKIN, NORTH CAROLINA 28621

DRAWN BY:
BKS

PROJECT NO:
MISC

DATE:
2023.02.01

SHEET NO:
S10

CONNECTION DETAILS

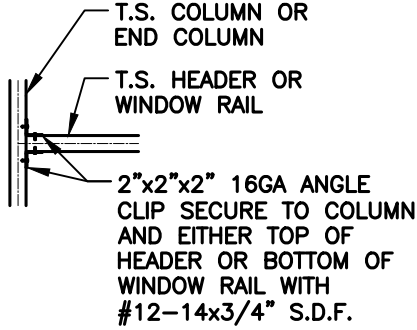

COLUMN OR WINDOW
RAIL / WALL GIRT TO POST
CONNECTION DETAIL

1
S11

SCALE: 1/2" = 1'-0"

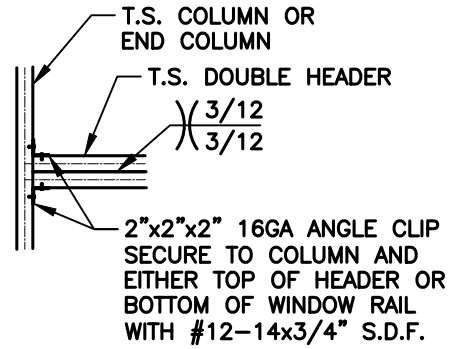

COLUMN / DOUBLE HEADER
CONNECTION DETAIL

1A
S11

SCALE: 1/2" = 1'-0"

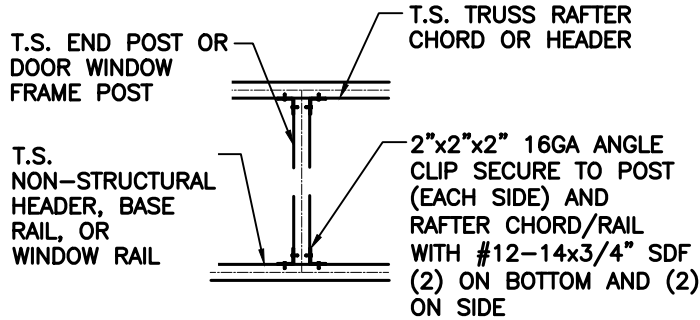

DOOR OR WINDOW HEADER
RAIL TO POST CONNECTION
DETAIL

2
S11

SCALE: 1/2" = 1'-0"

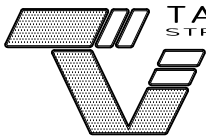

TAYLOR & VIOLA
STRUCTURAL ENGINEERS

P.O.B. 2616 HICKORY NORTH CAROLINA
TELE: 828-328-6331 FAX: 828-322-1801
WWW.TAYLORVIOLA.COM

N.C. CARPORT
& GARAGES

116 EAST MARKET STREET
ELKIN, NORTH CAROLINA 28621

DRAWN BY:
BKS

PROJECT NO:
MISC

DATE:
2023.02.01

SHEET NO:
S11

CONNECTION DETAILS

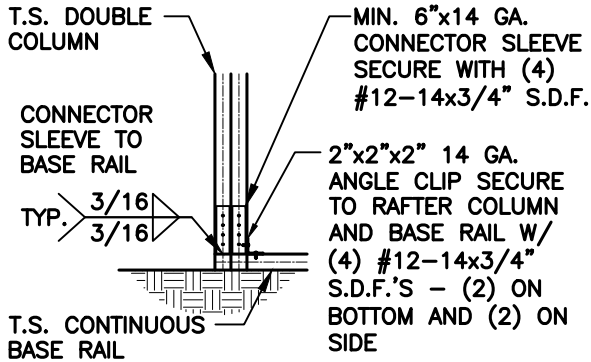

END COLUMN / BASE RAIL
CONNECTION DETAIL

1
S12

SCALE: 1/2" = 1'-0"

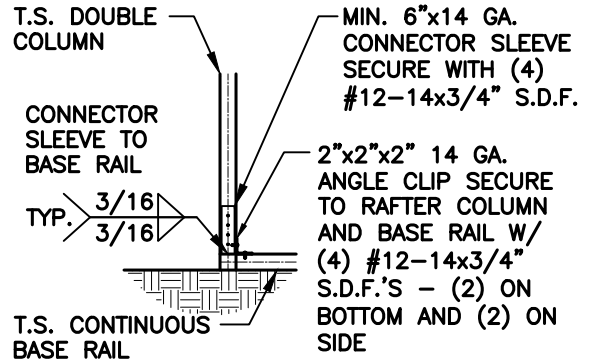

END COLUMN / BASE RAIL
CONNECTION DETAIL

1A
S12

SCALE: 1/2" = 1'-0"

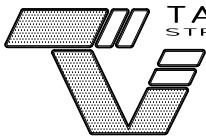

TAYLOR & VIOLA
STRUCTURAL ENGINEERS

P.O.B. 2616 HICKORY NORTH CAROLINA
TELE: 828-328-6331 FAX: 828-322-1801
WWW.TAYLORVIOLA.COM

N . C . CARPORT
& GARAGES

116 EAST MARKET STREET
ELKIN, NORTH CAROLINA 28621

DRAWN BY:
BKS

PROJECT NO:
MISC

DATE:
2023.02.01

SHEET NO:
S12

CONNECTION DETAILS

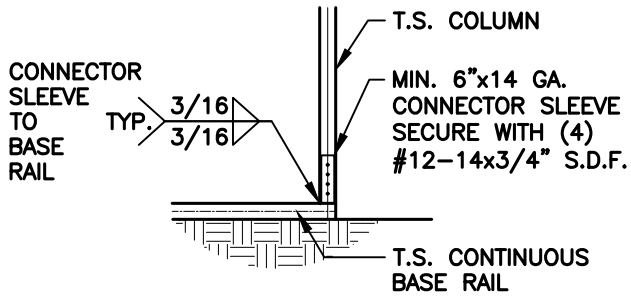

1
S13 COLUMN / BASE RAIL CONNECTION DETAIL

SCALE: 1/2" = 1'-0"

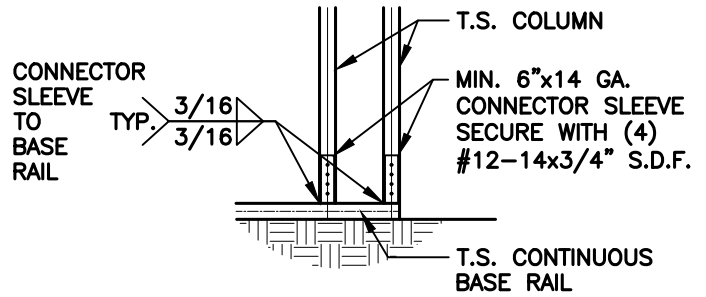

1A
S13 COLUMN / BASE RAIL CONNECTION DETAIL

SCALE: 1/2" = 1'-0"

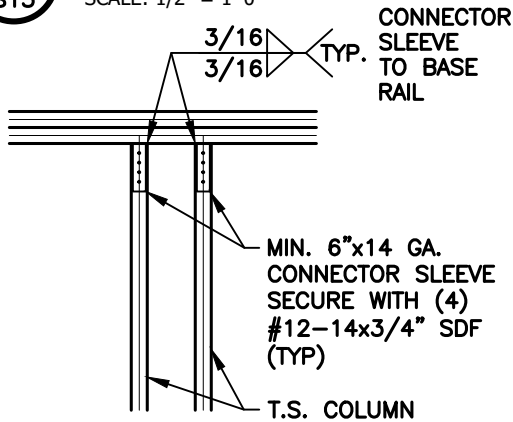

2
S13 DOUBLE HEADER / COLUMN CONNECTION DETAIL

SCALE: 1/2" = 1'-0"

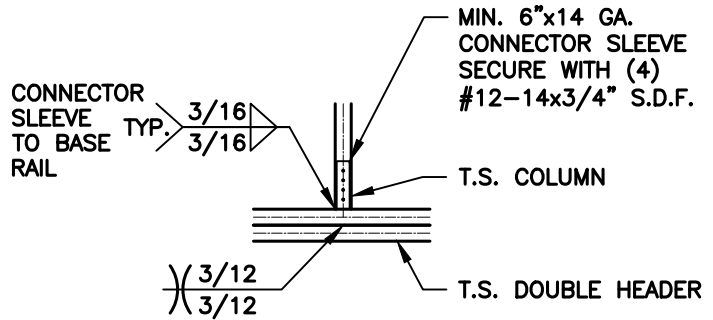

3
S13 COLUMN / DOUBLE HEADER CONNECTION DETAIL

SCALE: 1/2" = 1'-0"

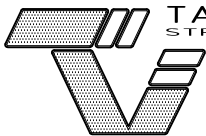

TAYLOR & VIOLA
STRUCTURAL ENGINEERS

P.O.B. 2616 HICKORY NORTH CAROLINA
TELE: 828-328-6331 FAX: 828-322-1801
WWW.TAYLORVIOLA.COM

N.C. CARPORT
& GARAGES

116 EAST MARKET STREET
ELKIN, NORTH CAROLINA 28621

DRAWN BY:
BKS

PROJECT NO:
MISC

DATE:
2023.02.01

SHEET NO:
S13

CONNECTION DETAILS

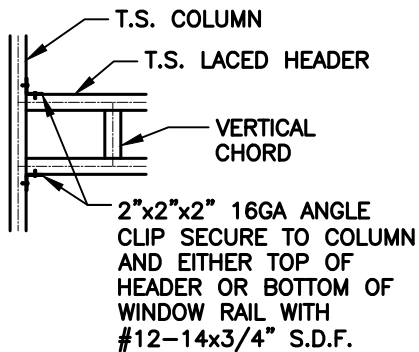

1
COLUMN / LACED HEADER CONNECTION DETAIL

S14

SCALE: 1/2" = 1'-0"

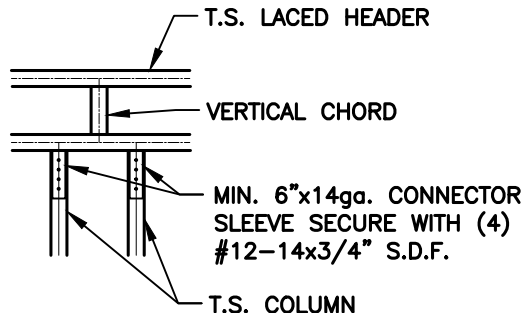

2
LACED HEADER / COLUMN CONNECTION DETAIL

S14

SCALE: 1/2" = 1'-0"

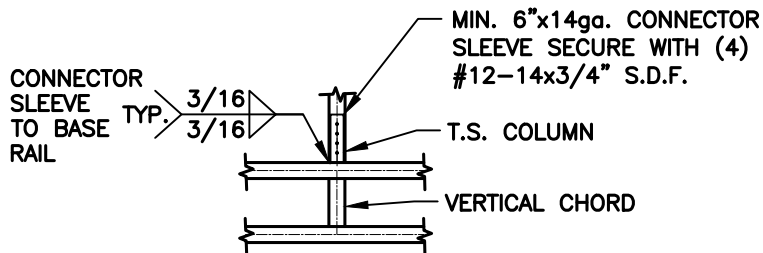

3
COLUMN / LACED HEADER CONNECTION DETAIL

S14

SCALE: 1/2" = 1'-0"

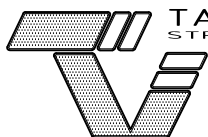

TAYLOR & VIOLA
STRUCTURAL ENGINEERS

P.O.B. 2616 HICKORY NORTH CAROLINA
TELE: 828-328-6331 FAX: 828-322-1801
WWW.TAYLORVIOLA.COM

N.C. CARPORT
& GARAGES

116 EAST MARKET STREET
ELKIN, NORTH CAROLINA 28621

DRAWN BY:
BKS

PROJECT NO:
MISC

DATE:
2023.02.01

SHEET NO:
S14

BOX EVE RAFTER LEAN-TO OPTIONS

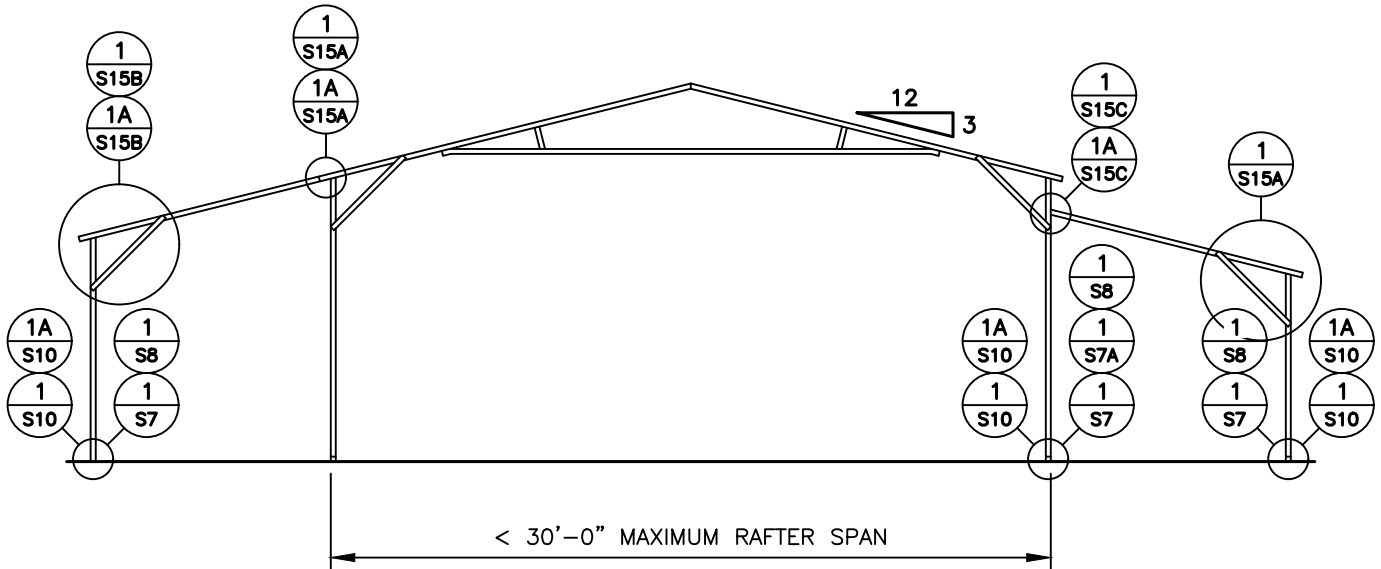

TYPICAL LEAN-TO OPTIONS FRAMING SECTION (BOTH OPTIONS SHOWN)

MAXIMUM WIDTH OF SINGLE MEMBER ROOF EXTENSION AND LEAN-TO OPTION IS 12'-0"

MAXIMUM WIDTH OF DOUBLE MEMBER ROOF EXTENSION AND LEAN-TO IS 15'-0"

12'-0" MAX. LEAN-TO HEIGHT WITH SINGLE COLUMN



TAYLOR & VIOLA
STRUCTURAL ENGINEERS

P.O.B. 2616 HICKORY NORTH CAROLINA
TELE: 828-328-6331 FAX: 828-322-1801
WWW.TAYLORVIOLA.COM

N . C . CARPORT
& GARAGES

116 EAST MARKET STREET
ELKIN, NORTH CAROLINA 28621

DRAWN BY:
BKS

PROJECT NO:
MISC

DATE:
2023.02.01

SHEET NO:
S15

LEAN-TO CONNECTION DETAILS

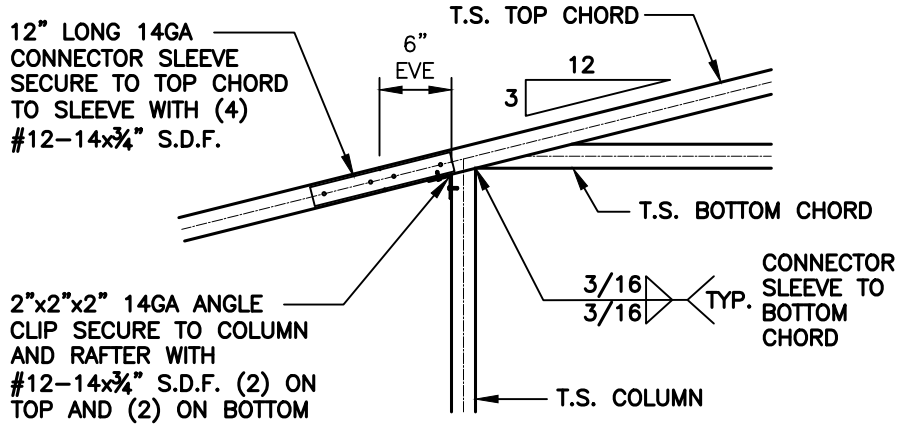

ROOF EXTENSION RAFTER / CORNER POST
DETAIL FOR WIDTHS < 12'-0"

1
S15A

SCALE: 3/4" = 1'-0"

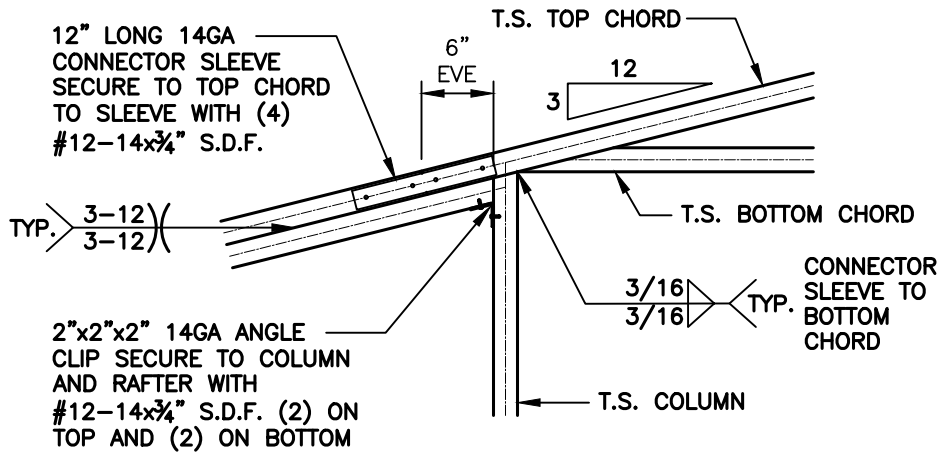

ROOF EXTENSION RAFTER / CORNER POST
DETAIL FOR WIDTHS < 15'-0"

1A
S15A

SCALE: 3/4" = 1'-0"

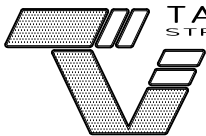

TAYLOR & VIOLA
STRUCTURAL ENGINEERS

P.O.B. 2616 HICKORY NORTH CAROLINA
TELE: 828-328-6331 FAX: 828-322-1801
WWW.TAYLORVIOLA.COM

N.C. CARPORT
& GARAGES

116 EAST MARKET STREET
ELKIN, NORTH CAROLINA 28621

DRAWN BY:
BKS

PROJECT NO:
MISC

DATE:
2023.02.01

SHEET NO:
S15A

LEAN-TO CONNECTION DETAILS

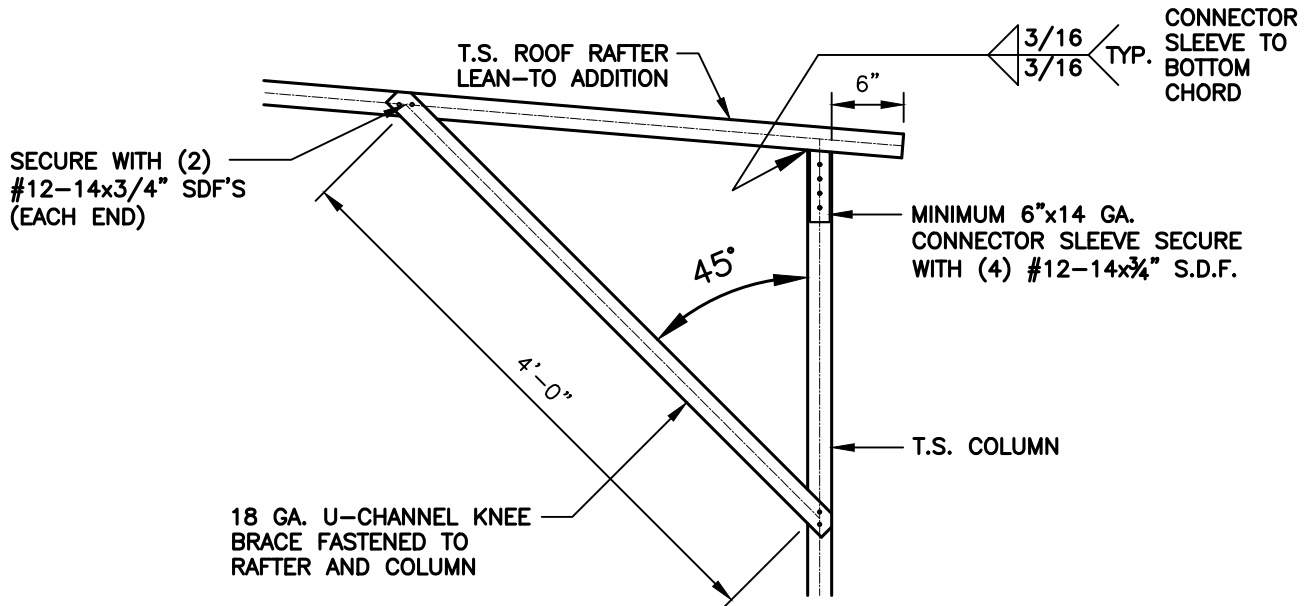

**BOX EAVE RAFTER COLUMN CONNECTION
DETAIL FOR LEAN-TO RAFTER SPAN <12'-0"**

1
S15B

SCALE: 3/4" = 1'-0"

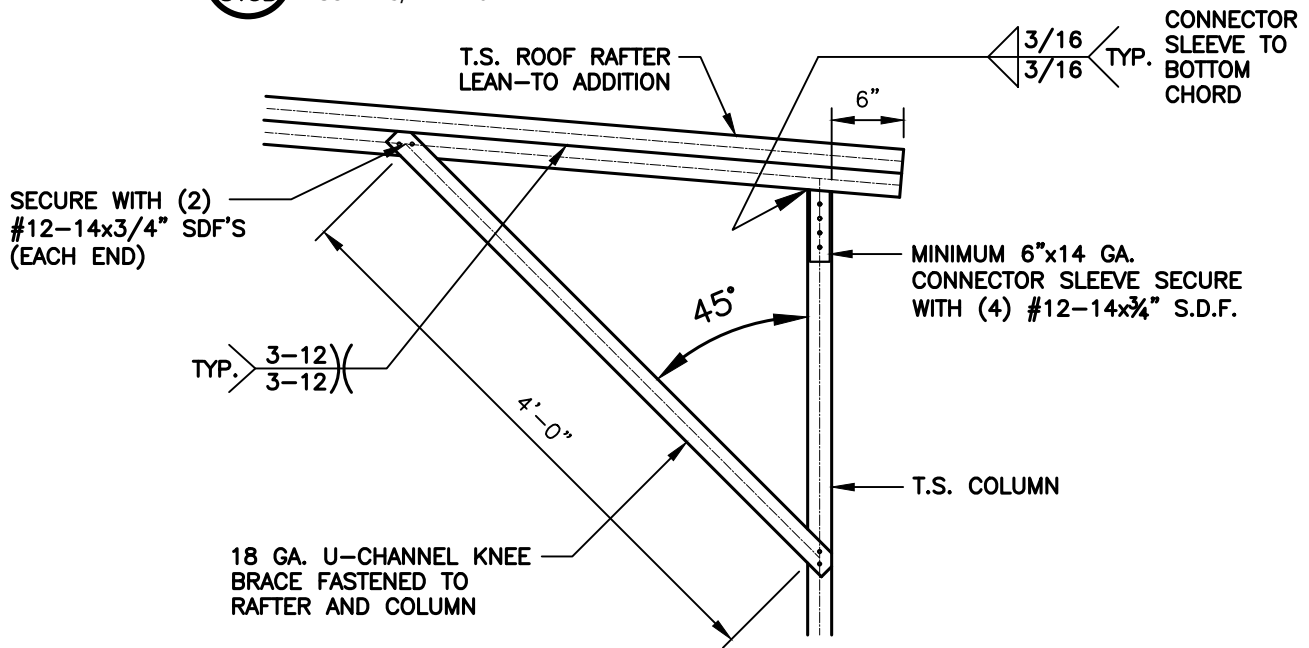

**BOX EAVE RAFTER COLUMN CONNECTION
DETAIL FOR LEAN-TO RAFTER SPAN <15'-0"**

1A
S15B

SCALE: 3/4" = 1'-0"



TAYLOR & VIOLA
STRUCTURAL ENGINEERS

P.O.B. 2616 HICKORY NORTH CAROLINA
TELE: 828-328-6331 FAX: 828-322-1801
WWW.TAYLORVIOLA.COM

N.C. CARPORT
& GARAGES

116 EAST MARKET STREET
ELKIN, NORTH CAROLINA 28621

DRAWN BY:
BKS

PROJECT NO:
MISC

DATE:
2023.02.01

SHEET NO:
S15B

LEAN-TO CONNECTION DETAILS

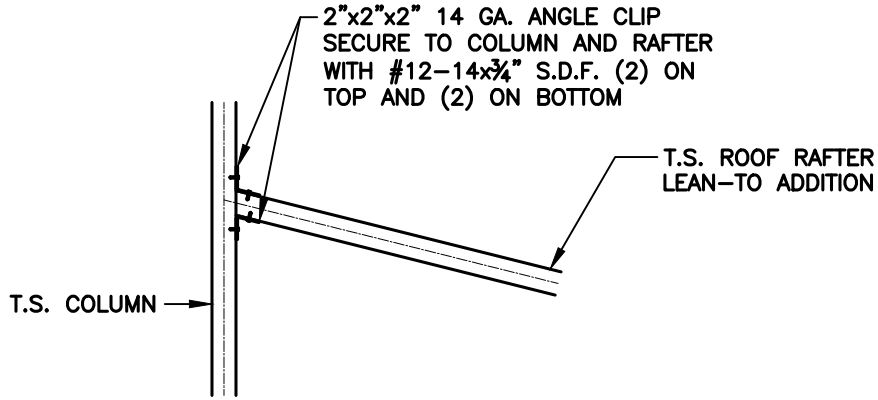

LEAN-TO RAFTER TO RAFTER POST
CONNECTION DETAIL FOR WIDTHS < 12'-0"

1
S15C

SCALE: 3/4" = 1'-0"

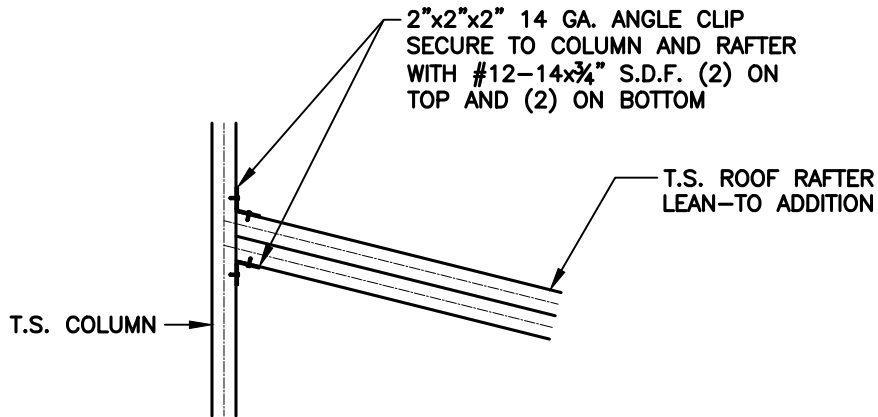

LEAN-TO RAFTER TO RAFTER POST
CONNECTION DETAIL FOR WIDTHS < 15'-0"

1A
S15C

SCALE: 3/4" = 1'-0"

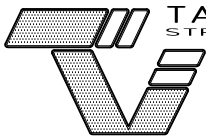

TAYLOR & VIOLA
STRUCTURAL ENGINEERS

P.O.B. 2616 HICKORY NORTH CAROLINA
TELE: 828-328-6331 FAX: 828-322-1801
WWW.TAYLORVIOLA.COM

N . C . CARPORT
& GARAGES

116 EAST MARKET STREET
ELKIN, NORTH CAROLINA 28621

DRAWN BY:
BKS

PROJECT NO:
MISC

DATE:
2023.02.01

SHEET NO:
S15C

VERTICAL ROOF / SIDING OPTION

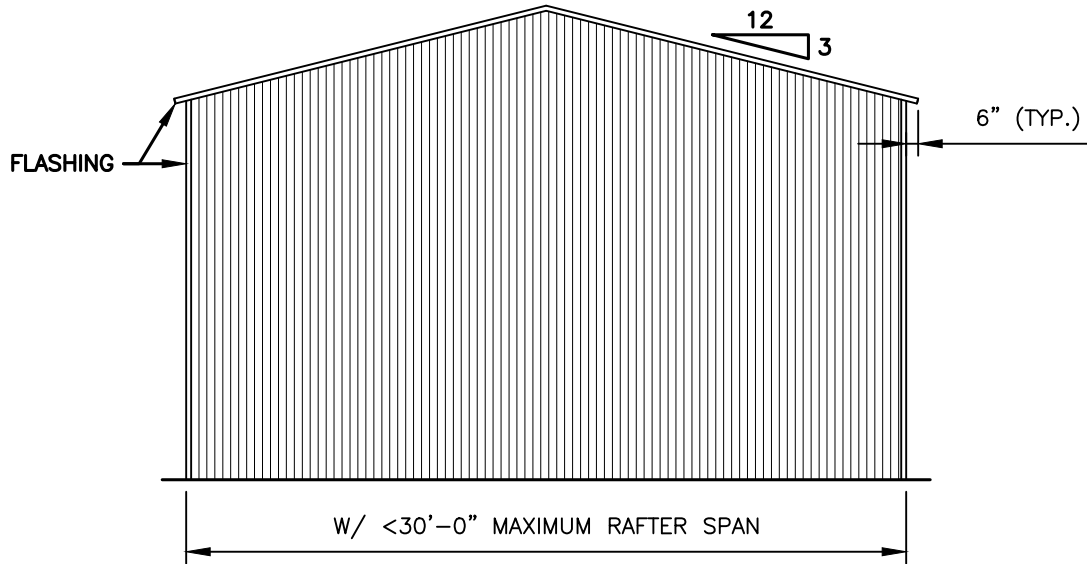

TYPICAL END ELEVATION - VERTICAL ROOF / SIDING

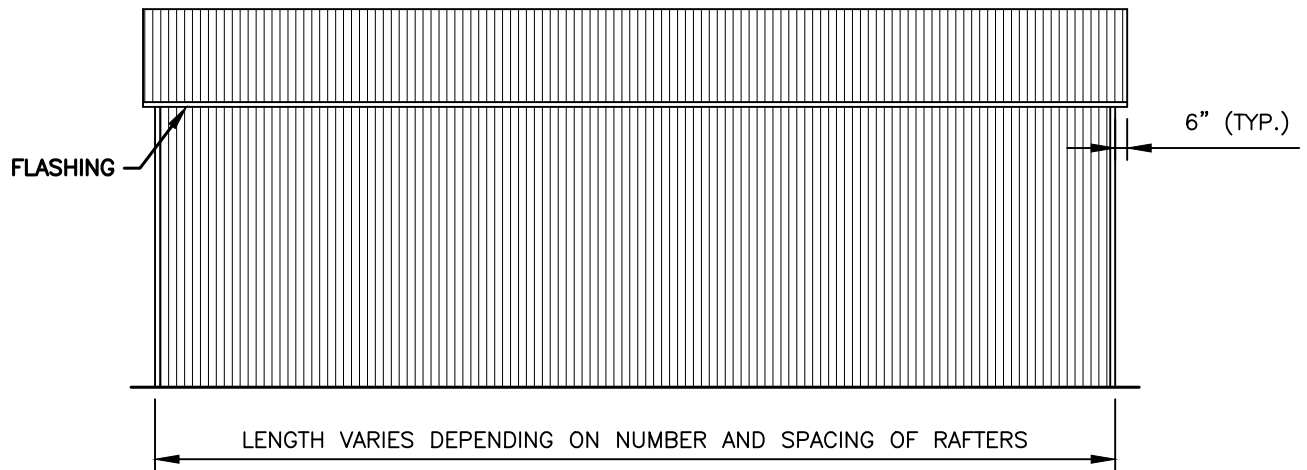

TYPICAL SIDE ELEVATION - VERTICAL ROOF / SIDING

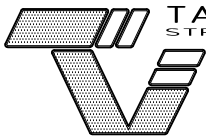

TAYLOR & VIOLA
STRUCTURAL ENGINEERS

P.O.B. 2616 HICKORY NORTH CAROLINA
TELE: 828-328-6331 FAX: 828-322-1801
WWW.TAYLORVIOLA.COM

N.C. CARPORT
& GARAGES

116 EAST MARKET STREET
ELKIN, NORTH CAROLINA 28621

DRAWN BY:
BKS

DATE:
2023.02.01

PROJECT NO:
MISC

SHEET NO:
S16

VERTICAL ROOF / SIDING OPTION

1.125"-18 GA. HAT CHANNELS
FASTENED TO EACH RAFTER
WITH (2) #12-14x3/4" S.D.F.
SPACED AT 4'-0"oc MAX.

29 GA. GALVANIZED
METAL ROOF AND WALL
PANELS FASTENED TO
HAT CHANNELS AND
GIRTS

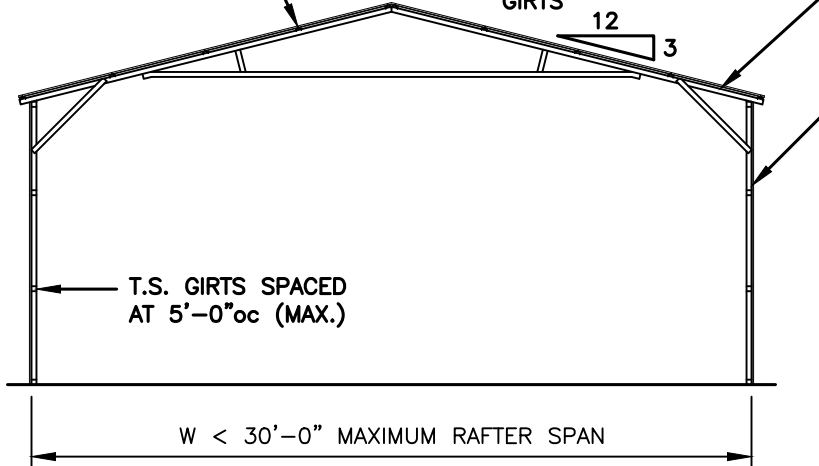

TYPICAL SECTION VERTICAL ROOF / SIDING OPTION

NOTE:
H.S.S. 2-1/2"x2-1/2"x14ga. OR
2-1/4"x2-1/4"x14ga. MATERIAL
MAY BE USED FOR TRUSS METAL.

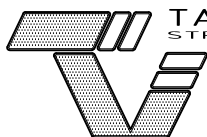

TAYLOR & VIOLA
STRUCTURAL ENGINEERS

P.O.B. 2616 HICKORY NORTH CAROLINA
TELE: 828-328-6331 FAX: 828-322-1801
WWW.TAYLORVIOLA.COM

N.C. CARPORT
& GARAGES

116 EAST MARKET STREET
ELKIN, NORTH CAROLINA 28621

DRAWN BY:
BKS

PROJECT NO:
MISC

DATE:
2023.02.01

SHEET NO:
S16A

VERTICAL ROOF / SIDING OPTION

SEE NOTES
(SHEET S3)
FOR MAXIMUM
SPACING

1.125"-18 GA. HAT CHANNELS
FASTENED TO EACH RAFTER
WITH (2) #12-14x3/4" S.D.F.
SPACED AT 4'-0"oc MAX.

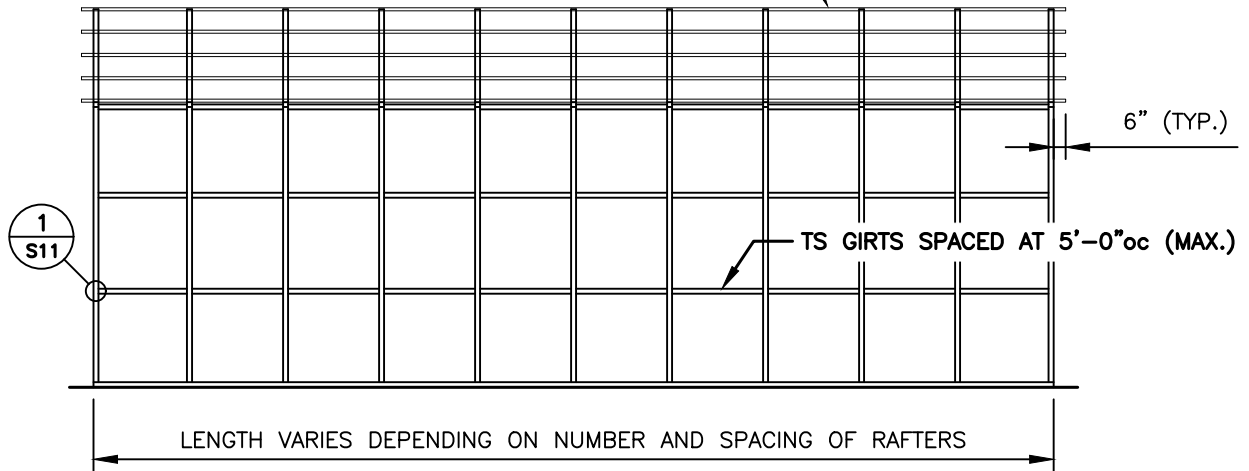

TYPICAL SIDE FRAMING SECTION VERTICAL ROOF / SIDING OPTION

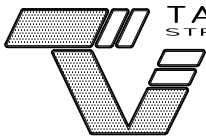
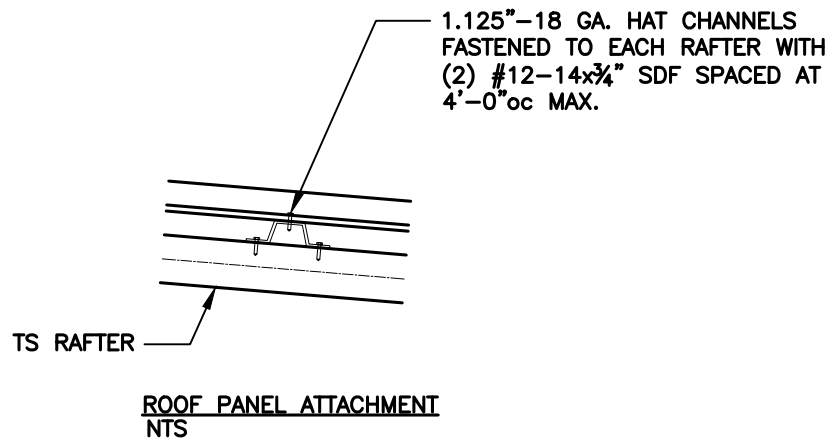

TAYLOR & VIOLA
STRUCTURAL ENGINEERS

P.O.B. 2616 HICKORY NORTH CAROLINA
TELE: 828-328-6331 FAX: 828-322-1801
WWW.TAYLORVIOLA.COM

N.C. CARPORT
& GARAGES

116 EAST MARKET STREET
ELKIN, NORTH CAROLINA 28621

DRAWN BY:
BKS

PROJECT NO:
MISC

DATE:
2023.02.01

SHEET NO:
S16B

SIDE WALL HEADER OPTIONS

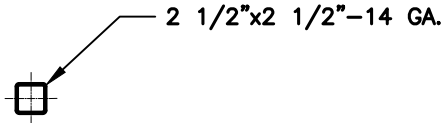

HEADER DETAIL FOR DOOR
OPENINGS < 4'-0"
 NTS

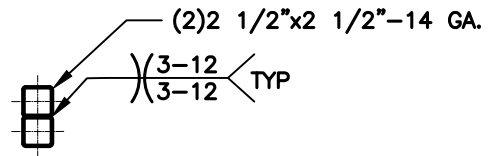

HEADER DETAIL FOR DOOR
OPENINGS 4'-1" < TO < 12'-0"
 NTS

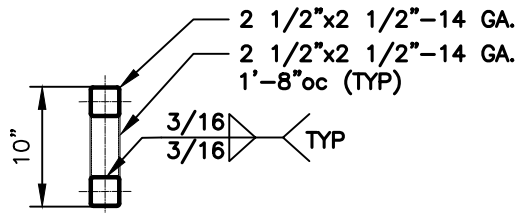

LACED HEADER DETAIL FOR DOOR
OPENINGS 12'-1" < TO < 15'-0"
 NTS

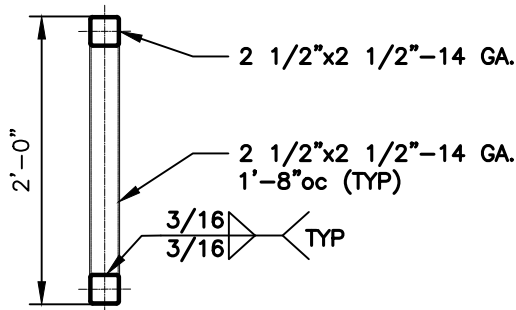

LACED HEADER DETAIL FOR DOOR
OPENINGS 15'-1" < TO < 20'-0"



TAYLOR & VIOLA
 STRUCTURAL ENGINEERS

P.O.B. 2616 HICKORY NORTH CAROLINA
 TELE: 828-328-6331 FAX: 828-322-1801
 WWW.TAYLORVIOLA.COM

N.C. CARPORT
 & GARAGES

116 EAST MARKET STREET
 ELKIN, NORTH CAROLINA 28621

DRAWN BY:
 BKS

PROJECT NO:
 MISC

DATE:
 2023.02.01

SHEET NO:
S17

END WALL HEADER OPTIONS

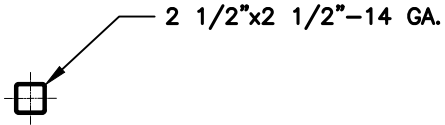

HEADER DETAIL FOR DOOR
OPENINGS < 7'-0"
 NTS

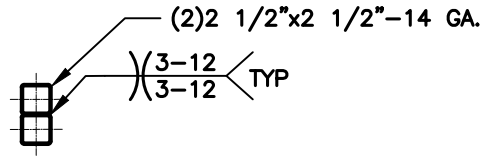

HEADER DETAIL FOR DOOR
OPENINGS 7'-1" < TO < 16'-0"
 NTS

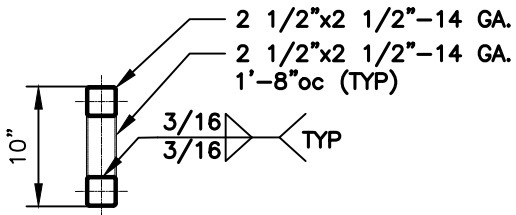

LACED HEADER DETAIL FOR DOOR
OPENINGS 16'-1" < TO < 20'-0"
 NTS



TAYLOR & VIOLA
 STRUCTURAL ENGINEERS

P.O.B. 2616 HICKORY NORTH CAROLINA
 TELE: 828-328-6331 FAX: 828-322-1801
 WWW.TAYLORVIOLA.COM

N . C . CARPORT
 & GARAGES

116 EAST MARKET STREET
 ELKIN, NORTH CAROLINA 28621

DRAWN BY:
 BKS

PROJECT NO:
 MISC

DATE:
 2023.02.01

SHEET NO:
S17A