

NOTICE TO CONTRACTOR
All construction shall comply with current NC Building Codes and is subject to final inspection and certification.

APPROVED
Contract Building with Insulation
Permit holder responsible for full compliance with the code.

08/04/2023



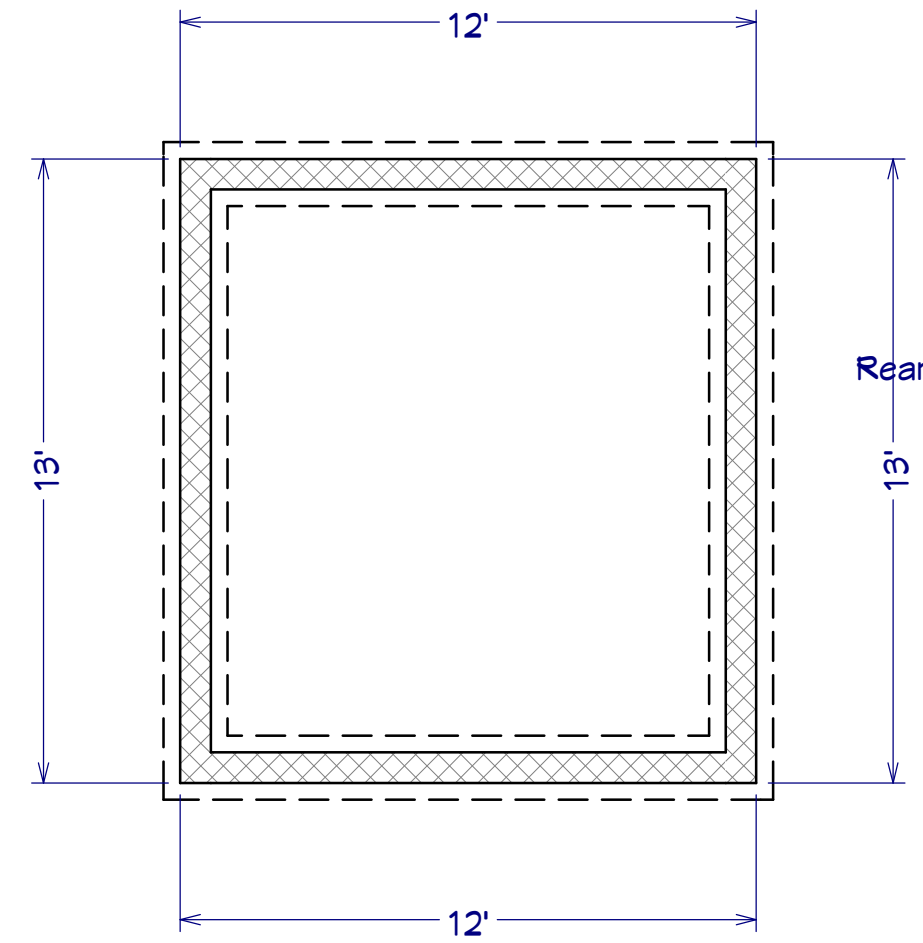

Front



R-38 minimum

- 2"x10"x12' floor joist
- r19 floor insulation
- r15 walls "
- r28 ceiling "
- footing 18"w x18" depth
- 8" concrete

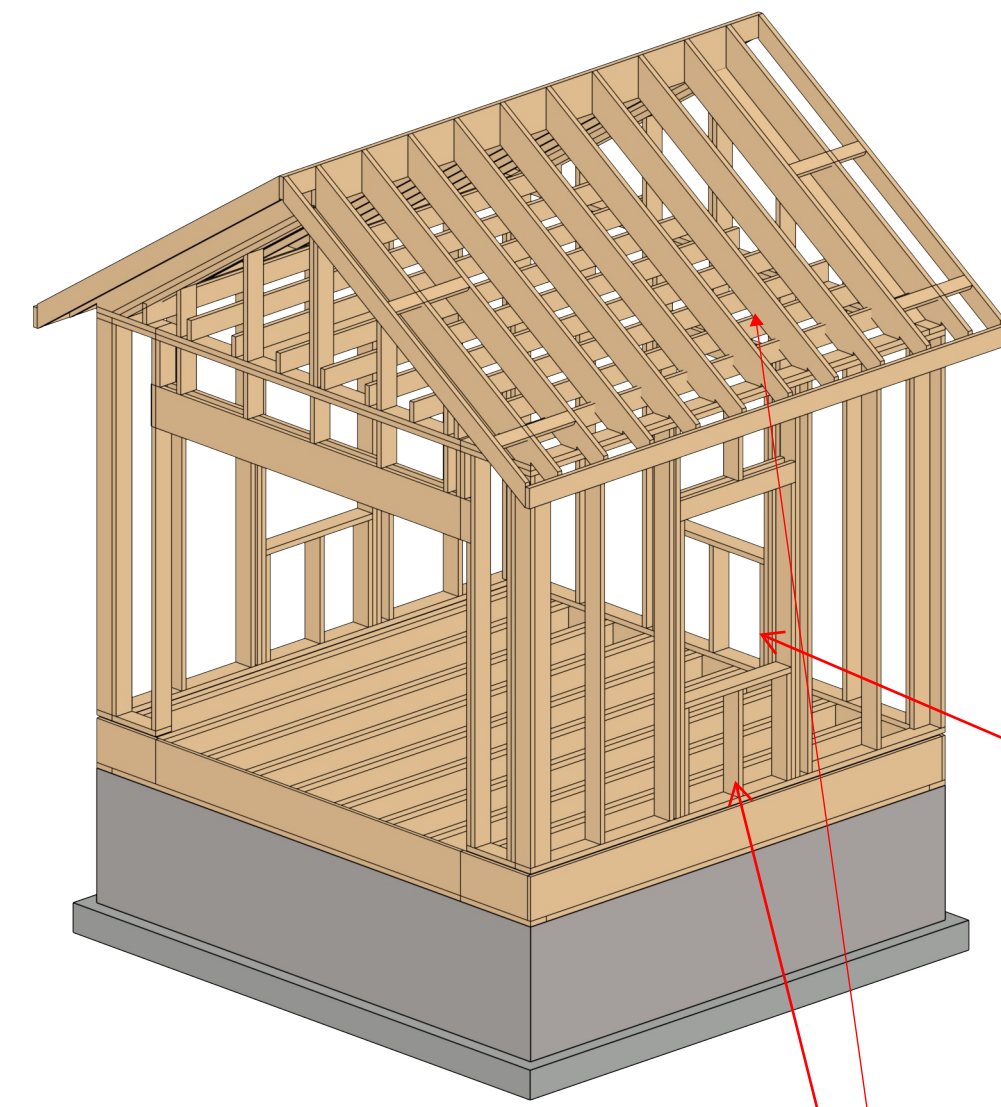
125 Irene ct
Fuquay, NC



Camera 2

- 2"x4"x93" studs
- cinder block foundation
- 2"x8" rafters
- 2"x6" ceiling joists
- 2-2"x10" headers

Windows must meet energy code

sheath with 7/16 osb minimum

--

NO.	DESCRIPTION	BY	DATE

SHEET TITLE:

SHEET TITLE

PROJECT DESCRIPTION:

PROJECT

DRAWINGS PROVIDED BY:

DESIGNER

DATE:

SCALE:

SHEET:

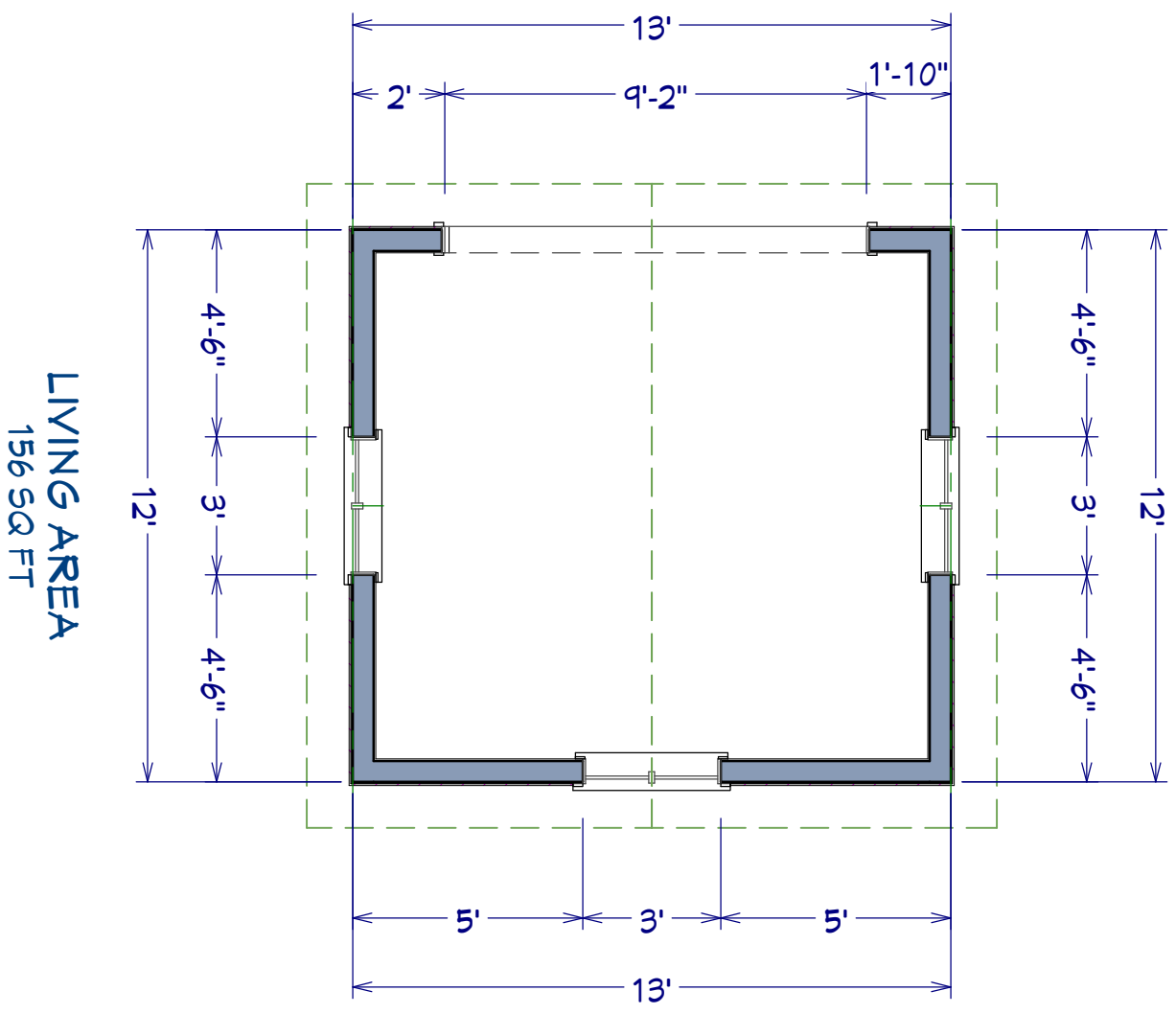

A-2

SHEET:

SCALE:

DATE:

DRAWINGS PROVIDED BY:

PROJECT DESCRIPTION:

SHEET TITLE:

NO.	DESCRIPTION	BY	DATE

