

**DISCLAIMER:** THESE PLANS, IDEAS, & CONCEPTS CONTAINED HEREIN, INCLUDING DIGITAL INFORMATION, ARE THE PROPERTY OF MK WEBER ENGINEERING AND ARE NOT TO BE COPIED, REPRODUCED, MODIFIED, OR CHANGED IN ANY FORM OR MANNER WITHOUT WRITTEN PERMISSION OF MK WEBER ENGINEERING. UNAUTHORIZED CHANGES TO THESE DRAWINGS AND WORK NOT DESCRIBED BY THESE DRAWINGS ARE NOT COVERED BY THE ENGINEER CERTIFICATION. VIOLATION OF THE COPYRIGHT LAWS MAY RESULT IN LEGAL ACTION. THESE PLANS ARE ONLY PERMISSIBLE FOR ONE USE, FOR THE ADDRESS NOTATED IN THE TITLE BLOCK. UTILIZING THESE PLANS FOR ANY OTHER PROJECT AT THE SAME SITE OR ANY OTHER SITE IS NOT PERMITTED AND WILL RESULT IN LEGAL ACTION TAKEN AGAINST THE PARTY REUSING OR REPRODUCING THESE PLANS. THESE PLANS ARE NOT VALID WITHOUT A RAISED SEAL. THESE PLANS ARE NOT VALID IF ANY HANDWRITTEN INFORMATION IS PRESENT, APART FROM THE LICENSEE'S SIGNATURE.

**STRUCTURAL NOTES**

**GENERAL**

**1. DESIGN CODE DATA**

2018 INTERNATIONAL BUILDING CODE  
 ASCE 7-16: MINIMUM DESIGN LOADS FOR BUILDINGS AND OTHER STRUCTURES.  
 AISC 360-05: SPECIFICATION FOR STRUCTURAL STEEL BUILDINGS

**2. DESIGN LOADS:**

ROOF DEAD LOADS: 10 PSF  
 ROOF LIVE LOADS: 20 PSF

**3. WIND DESIGN CRITERIA**

WIND LOAD: 150 MPH 3 SECOND GUST  
 NOMINAL DESIGN WIND SPEED: 116 MPH  
 INTERNAL PRESSURE COEFFICIENT: 0.0 (OPEN)  
 RISK CATEGORY 1 BUILDING (THIS STRUCTURE IS DESIGNED AS AN UNINHABITABLE STRUCTURE AND SHALL NOT BE CONVERTED TO A HABITABLE WITHOUT PRIOR APPROVAL FROM ENGINEER OF RECORD)  
 EXPOSURE CATEGORY B  
 BASE VELOCITY PRESSURE: 34.3 PSF

4. THE CONTRACTOR IS RESPONSIBLE FOR LIMITING THE AMOUNT OF CONSTRUCTION LOAD IMPOSED UPON OR EXISTING STRUCTURAL FRAMING. CONSTRUCTION LOADS SHALL NOT EXCEED THE DESIGN CAPACITY OF THE FRAMING AT THE TIME THE LOADS ARE IMPOSED.

COMPONENTS AND CLADDING				
ROOFS	DESIGN PRESSURE (ULT)		DESIGN PRESSURE (ASD)	
	POSITIVE (PSF)	NEGATIVE (PSF)	POSITIVE (PSF)	NEGATIVE (PSF)
TRIBUTARY AREA 10 SF				
ZONE 1 max	33.4	30.7	20.0	18.4
ZONE 2 max	51.6	47.6	30.9	28.5
ZONE 3 max	66.8	61.5	40.1	36.9
TRIBUTARY AREA 100 SF				
ZONE 1 max	33.4	30.7	20.0	18.4
ZONE 2 max	33.4	47.6	20.0	28.5
ZONE 3 max	33.4	47.6	20.0	28.5
WALLS				
DESIGN PRESSURE				
TRIBUTARY AREA 10 SF	POSITIVE (PSF)	NEGATIVE (PSF)	POSITIVE (PSF)	NEGATIVE (PSF)
ZONE 4	34.3	37.7	20.6	22.6
ZONE 5	34.3	48.0	20.6	28.8
TRIBUTARY AREA 100 SF	POSITIVE (PSF)	NEGATIVE (PSF)	POSITIVE (PSF)	NEGATIVE (PSF)
ZONE 4	28.2	31.7	16.9	19.0
ZONE 5	28.2	35.9	16.9	21.5

BUILDING RISK CATEGORY 1 - AGRICULTURAL STORAGE STRUCTURES INTENDED ONLY FOR INCIDENTAL HUMAN OCCUPANCY, OR A DETACHED ONE & TWO FAMILY DWELLING ASSIGNED SDC A, B, OR C, OR WITH A Ss, IS LESS THAN 0.4g.

**5. SNOW LOAD (S)**

19.00psf = Roof Snow Load 25psf = Ground Snow Load  
 Thermal Factor = 1.00 Snow Exposure Factor = 1.00 Snow Importance Factor = 0.80

**6. SEISMIC LOAD (E)**

Equivalent Lateral Force Procedure  
 0.35 = 0.2s Short Period Spectral Response Acceleration S(s)  
 0.12 = 1.0s Spectral Response Acceleration S(1)  
 Site Classification = D  
 Seismic Importance Factor = 1.00  
 Seismic Design Category = C  
 Seismic Design Short Period Acceleration, Sds = 0.355  
 Seismic Design 1 Sec Period Acceleration, SD1 = 1.189  
 Cantilever Columns for Timber Frames, R=1.5 Transverse & Longitudinal.

Analysis Procedure: Under Section 1613 of the IBC 2018, Earthquake Loads are not required to be considered for a Risk Category 1 Structure.

7. THE STRUCTURE IS DESIGNED TO FUNCTION AS A UNIT UPON COMPLETION. THE CONTRACTOR IS RESPONSIBLE FOR DESIGNING AND FURNISHING ALL TEMPORARY BRACING AND/OR SUPPORT THAT MAY BE REQUIRED AS THE RESULT OF THE CONTRACTOR'S CONSTRUCTION METHODS AND/OR SEQUENCES. THE STRUCTURAL ENGINEER ASSUMES NO LIABILITY FOR THE STRUCTURE DURING CONSTRUCTION.

8. THE CONTRACTOR IS RESPONSIBLE FOR ALL MEANS AND METHODS OF CONSTRUCTION AND ALL JOB SITE SAFETY.

9. VERIFY ALL DIMENSIONS PRIOR TO THE START OF CONSTRUCTION - DO NOT SCALE DRAWINGS.

**10. CONCRETE**

FOOTING AND FOUNDATION WALL 3,000 PSI @ 28 DAYS  
 SLAB ON GRADE 3,000 PSI @ 28 DAYS  
 ALL OTHER CIP CONCRETE 3,000 PSI @ 28 DAYS  
 CONCRETE REINFORCING STEEL 60 KSI, ASTM A615

**11. FOUNDATION**

- ALLOWABLE SOIL BEARING CAPACITY = 2,000 PSF FOR FOOTINGS (PRESUMPTIVE)
- GRADE AREAS IN ACCORDANCE WITH ELEVATIONS AND GRADES SHOWN ON THE SITE DRAWINGS AND AS REQUIRED FOR DRAINAGE.
- ALL SLAB ON GRADE AREAS SHALL BE PROOF ROLLED. ALL SOFT SPOTS SHALL BE REMOVED AND REPLACED WITH COMPACTABLE FILL.
- SLAB ON GRADE TO BE CONSTRUCTED ON A MINIMUM OF 6" OF COMPACTED GRANULAR FILL.
- ALL FILL MATERIAL USED IN GRADING OPERATIONS SHALL CONSIST OF EARTH, WHICH IS FREE OF DEBRIS, BOULDERS OR ORGANIC MATERIAL. FILL SHALL BE PLACED IN MAXIMUM OF 12" LIFTS AND COMPACTED TO 95% OF MODIFIED PROCTOR MAXIMUM DRY DENSITY.
- ALL FOOTINGS SHALL BEAR ON UNDISTURBED SOIL OR COMPACTED FILL HAVING A MINIMUM ALLOWABLE BEARING CAPACITY AS INDICATED ABOVE.
- THE ENGINEER SHALL BE NOTIFIED IF ACTUAL FIELD CONDITIONS DO NOT MEET BEARING REQUIREMENTS OR, IF QUESTIONABLE SOIL CONDITIONS ARE DISCOVERED INCLUDING BUT NOT LIMITED TO PEAT AND OTHER HIGH ORGANIC SOILS.
- ANY FOUNDATION UNDER THE BASE FLOOD ELEVATION SHALL COMPLY W/ R322.2.2 OF THE FLORIDA BUILDING CODE & WILL PROVIDE FLOOD VENTS TO MEET THESE REQUIREMENTS.

**12. STEEL**

ANGLES, PLATES, AND CHANNELS 36 KSI, ASTM A36  
 SQUARE AND RECTANGULAR HSS 46 KSI, ASTM A500 GRADE B,  
 BOLTS @ RIDGE (PEAK): (2) GRADE A5, 5/8" W/ A325 BOLTS  
 (4) FLAT & (2) LOCK WASHERS  
 BOLTS @ TRUSS TO POST CONN. (2) 5/8" X 12" CARRIAGE BOLTS &  
 (4) 2"x2"x1/8" FLAT & LOCK WASHERS  
 WELDING ELECTRODES E70XX  
 (ALL WELDS ARE FULL PENETRATION WELDS U.N.O.)

**13. WOOD**

2x8 AND SMALLER SYP NO. 2 OR BETTER  
 MINIMUM DESIGN VALUES  
 Fb 1,500 PSI  
 Ft 825 PSI  
 Fv 175 PSI  
 Fc<sub>⊥</sub> 565 PSI  
 Fc<sub>||</sub> 1,600 PSI  
 E 1,600,000 PSI  
 Emin 580,000 PSI

**WIND ZONES**

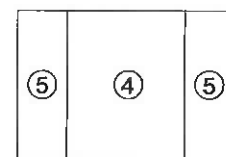

WALL  
 \*3'-0" EDGE DISTANCE

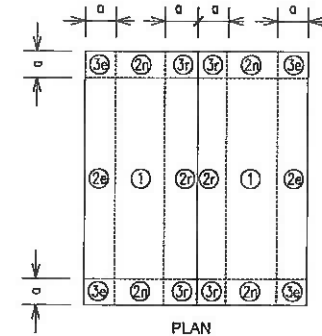

Gable and Flat Roofs 7° < θ < 45°

6x6, 8X8 OR 10X10 WD POST TREATED SOUTHERN YELLOW PINE (SYP)

MINIMUM DESIGN VALUES  
 Fb 1,350 PSI  
 E 1,500,000 PSI

**14. ROOF & WALL SHEATHING**

ROOF METAL PANELS SHALL BE 26 GA. x 3'-0" WIDE w/ 5 RIBS (RECOMMENDED)  
 OR 29 GA. x 3'-0" WIDE w/ 5 RIBS

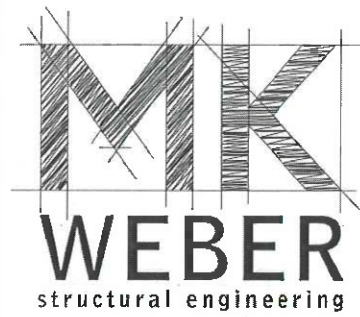

3200 W. 23RD STREET  
 PANAMA CITY, FL 32405  
 MKWEBER.COM

8/17/22  
*Michael K. Weber*

EOR: MICHAEL K. WEBER P.E.  
 STRUCTURAL ENGINEER  
 NORTH CAROLINA P.E. # 043557

EMBOSSED/WET STAMP  
 SCANNED AND ELECTRONICALLY TRANSMITTED COPIES OF THIS DOCUMENT ARE NOT CONSIDERED SIGNED AND SEALED. SIGNATURE IS NOT CONSIDERED VALID WITHOUT THE PRESENCE OF BLUE INK

DIGITAL  
 PRINTED COPIES OF THIS DOCUMENT ARE NOT CONSIDERED SIGNED AND SEALED AND THE SIGNATURE MUST BE VERIFIED ON THE ELECTRONIC COPIES

12'-50' HSS Tube Truss Drawings for:  
 Blackwater Truss Systems  
 8736 Hwy 87 N.  
 Milton, FL 32570

REV.	DESCRIPTION	DATE

JOB NUMBER: 22007-40  
 DRAWN BY: DAW  
 CHECKED BY: MKW  
 PLOT DATE: 8/17/2022

SHEET TITLE  
 GENERAL NOTES  
 DRAWING NUMBER  
**S100**

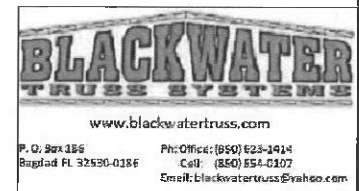

**DISCLAIMER:** THESE PLANS, IDEAS, & CONCEPTS CONTAINED HEREIN, INCLUDING DIGITAL INFORMATION, ARE THE PROPERTY OF MK WEBER ENGINEERING AND ARE NOT TO BE COPIED, REPRODUCED, MODIFIED, OR CHANGED IN ANY FORM OR MANNER WITHOUT WRITTEN PERMISSION OF MK WEBER ENGINEERING. UNAUTHORIZED CHANGES TO THESE DRAWINGS AND WORK NOT DESCRIBED BY THESE DRAWINGS ARE NOT COVERED BY THE ENGINEER CERTIFICATION. VIOLATION OF THE COPYRIGHT LAWS MAY RESULT IN LEGAL ACTION. THESE PLANS ARE ONLY PERMISSIBLE FOR ONE USE, FOR THE ADDRESS NOTATED IN THE TITLE BLOCK. UTILIZING THESE PLANS FOR ANY OTHER PROJECT AT THE SAME SITE OR ANY OTHER SITE IS NOT PERMITTED AND WILL RESULT IN LEGAL ACTION TAKEN AGAINST THE PARTY REUSING OR REPRODUCING THESE PLANS. THESE PLANS ARE NOT VALID WITHOUT A RAISED SEAL. THESE PLANS ARE NOT VALID IF ANY HANDWRITTEN INFORMATION IS PRESENT, APART FROM THE LICENSEE'S SIGNATURE.

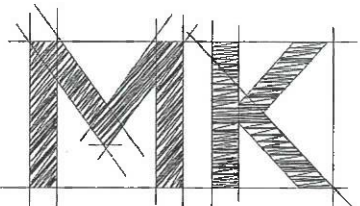

**WEBER**  
structural engineering

3200 W. 23RD STREET  
PANAMA CITY, FL 32405  
MKWEBER.COM

8/17/22  
*[Signature]*

EOR: MICHAEL K. WEBER P.E.  
STRUCTURAL ENGINEER  
NORTH CAROLINA P.E. # 043557

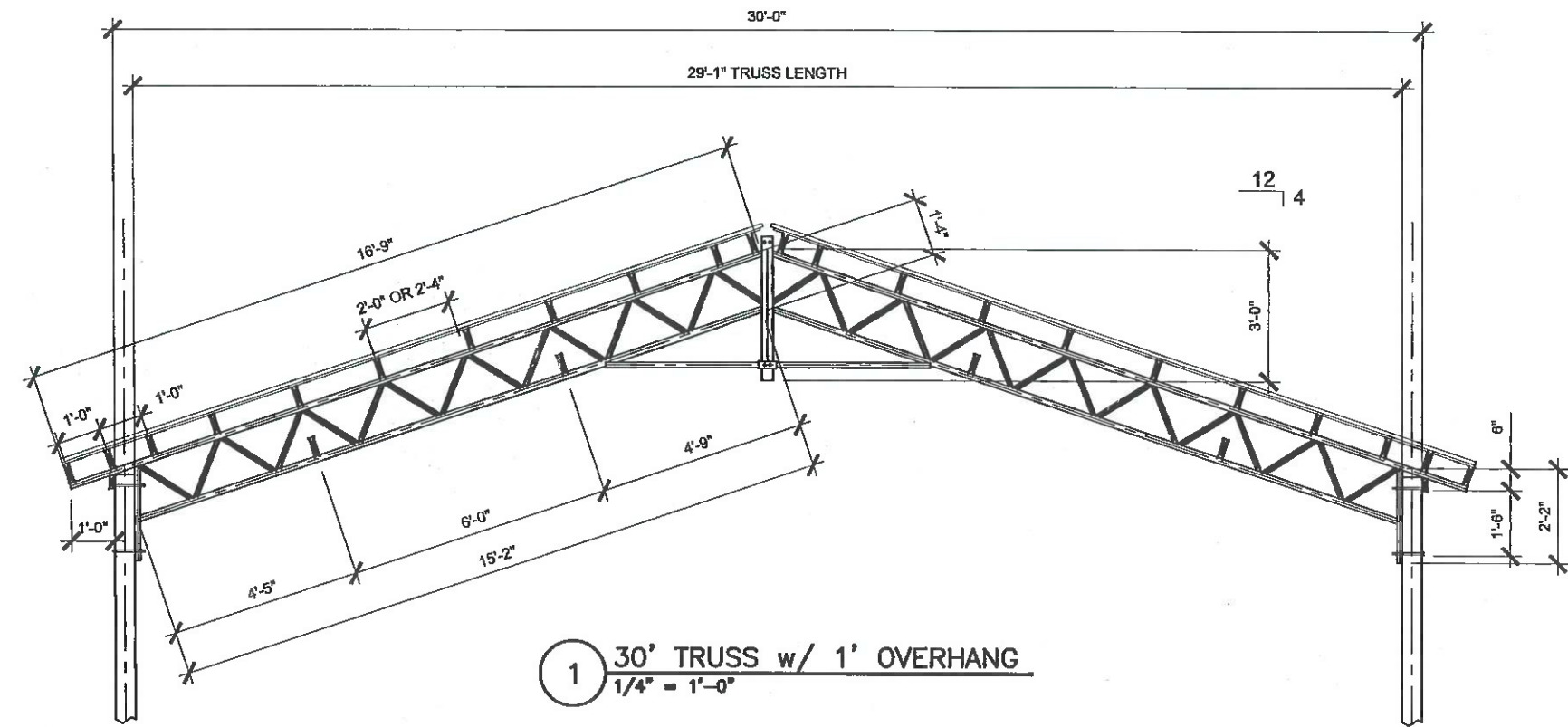

1 30' TRUSS w/ 1' OVERHANG  
1/4" = 1'-0"

ALL HOLES IN CHORD & WEB ITEMS ARE 11/16" Ø, 1" FROM ENDS AND/OR CENTERED RELATIVE TO ENDS.

TOP CHORD SHALL BE HSS1-1/2x1-1/2x14 GA.

BOTTOM CHORD SHALL BE HSS1-1/2x1-1/2x14 GA.

DIAGONAL WEB MEMBERS SHALL BE HSS1x1x14 GA.

VERTICAL ENDS SHALL BE L1-1/2x1-1/2x3/16

RIDGE COLLAR-TIE SHALL BE L1-1/2x1-1/2x11 GA.

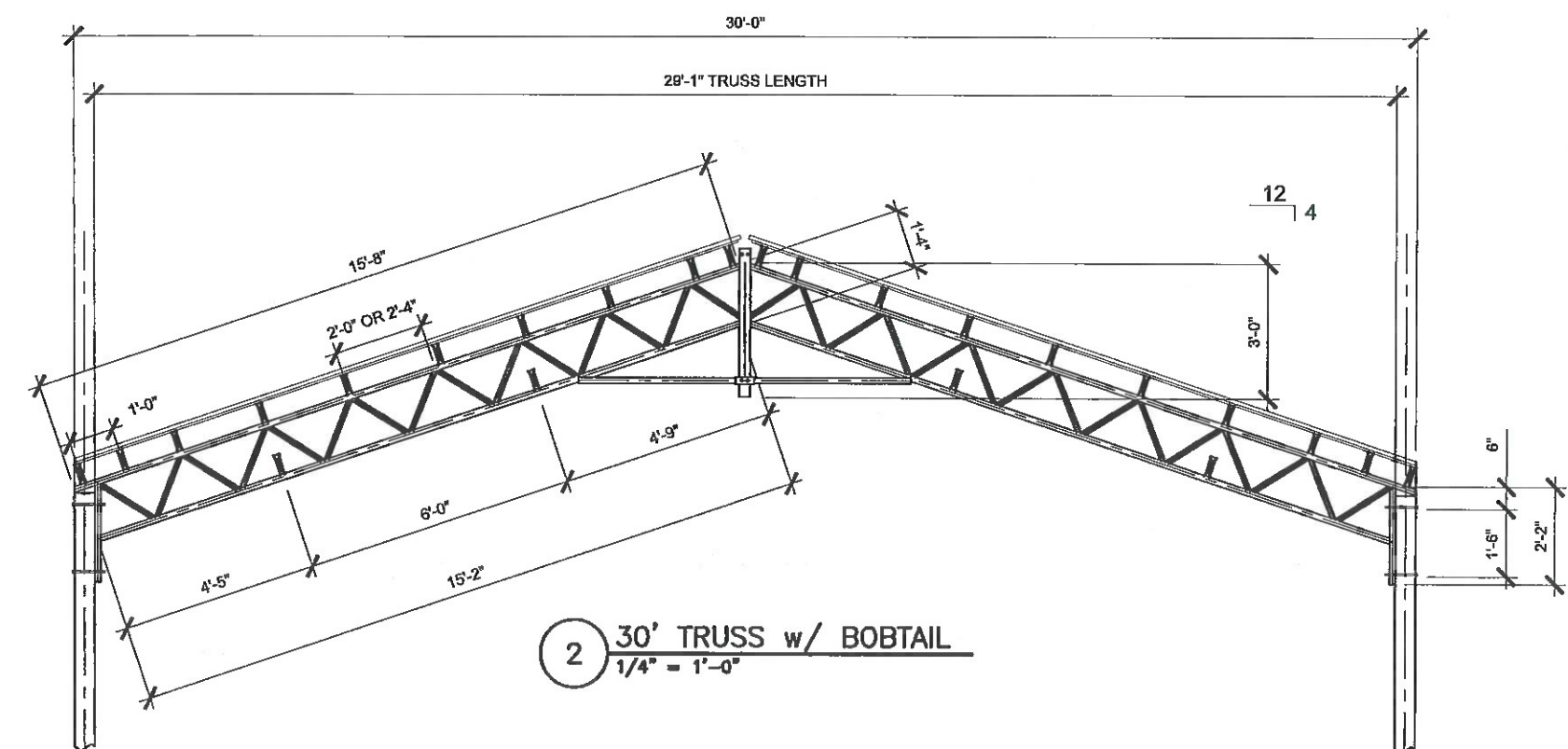

2 30' TRUSS w/ BOBTAIL  
1/4" = 1'-0"

EMBOSSED/ WET STAMP	DIGITAL
SCANNED AND ELECTRONICALLY TRANSMITTED COPIES OF THIS DOCUMENT ARE NOT CONSIDERED SIGNED AND SEALED. SIGNATURE IS NOT CONSIDERED VALID WITHOUT THE PRESENCE OF BLUE INK	PRINTED COPIES OF THIS DOCUMENT ARE NOT CONSIDERED SIGNED AND SEALED AND THE SIGNATURE MUST BE VERIFIED ON THE ELECTRONIC COPIES

12'-50' HSS Tube Truss Drawings for: Blackwater Truss Systems 8736 Hwy 87 N. Milton, FL 32570	REV.	DESCRIPTION	DATE

JOB NUMBER: 22007-40  
DRAWN BY: DAW  
CHECKED BY: MKW  
PLOT DATE: 8/17/2022

SHEET TITLE  
30' TRUSS PLAN

DRAWING NUMBER  
S106

**DISCLAIMER:** THESE PLANS, IDEAS, & CONCEPTS CONTAINED HEREIN, INCLUDING DIGITAL INFORMATION, ARE THE PROPERTY OF MK WEBER ENGINEERING AND ARE NOT TO BE COPIED, REPRODUCED, MODIFIED, OR CHANGED IN ANY FORM OR MANNER WITHOUT WRITTEN PERMISSION OF MK WEBER ENGINEERING. UNAUTHORIZED CHANGES TO THESE DRAWINGS AND WORK NOT DESCRIBED BY THESE DRAWINGS ARE NOT COVERED BY THE ENGINEER CERTIFICATION. VIOLATION OF THE COPYRIGHT LAWS MAY RESULT IN LEGAL ACTION. THESE PLANS ARE ONLY PERMISSIBLE FOR ONE USE, FOR THE ADDRESS NOTATED IN THE TITLE BLOCK. UTILIZING THESE PLANS FOR ANY OTHER PROJECT AT THE SAME SITE OR ANY OTHER SITE IS NOT PERMITTED AND WILL RESULT IN LEGAL ACTION TAKEN AGAINST THE PARTY REUSING OR REPRODUCING THESE PLANS. THESE PLANS ARE NOT VALID WITHOUT A RAISED SEAL. THESE PLANS ARE NOT VALID IF ANY HANDWRITTEN INFORMATION IS PRESENT, APART FROM THE LICENSEE'S SIGNATURE.

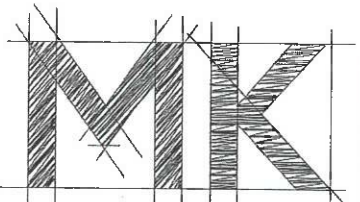

**WEBER**  
structural engineering

3200 W. 23RD STREET  
PANAMA CITY, FL 32405  
MKWEBER.COM

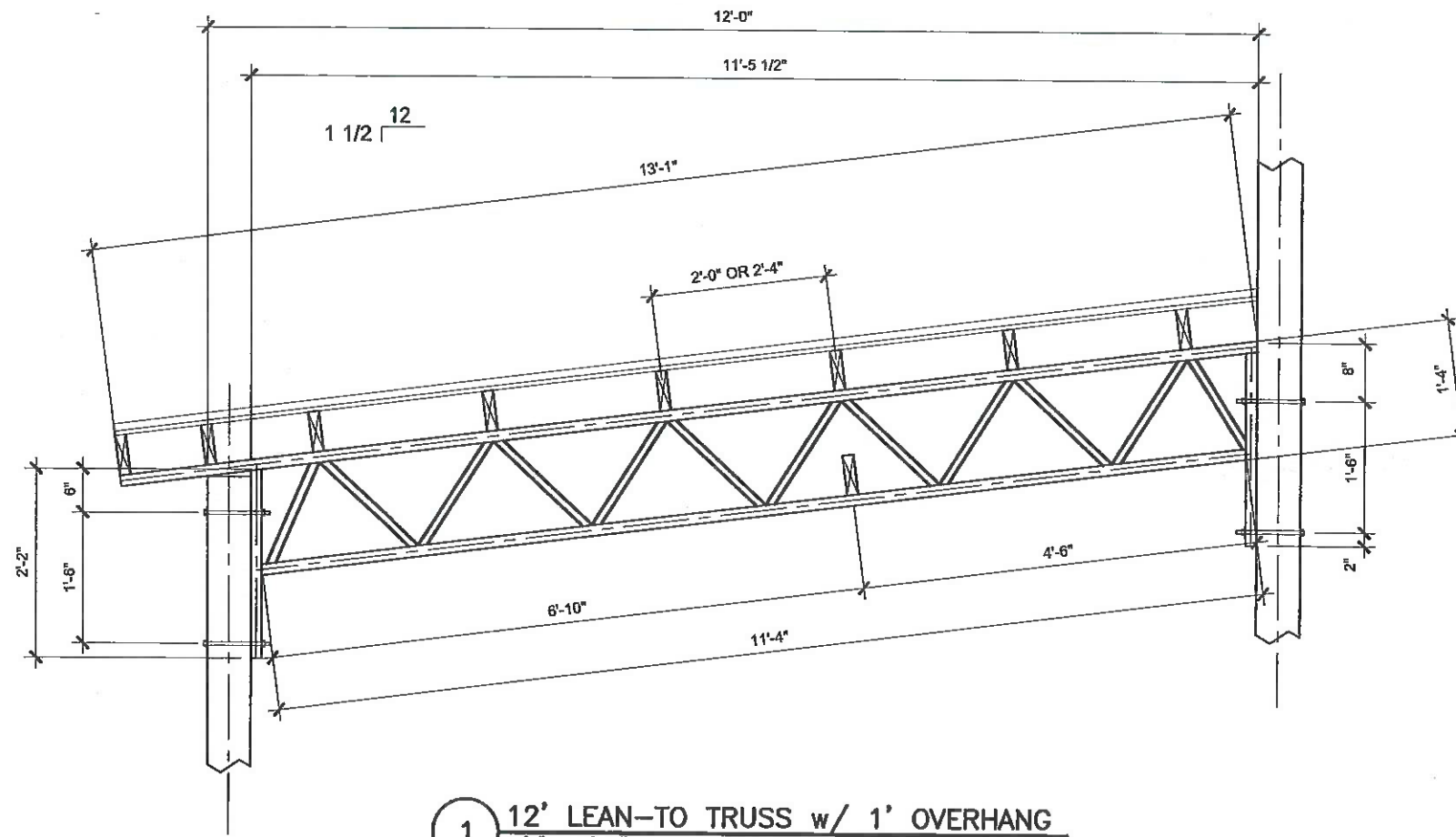

1 12' LEAN-TO TRUSS w/ 1' OVERHANG  
1/2" = 1'-0"

- ALL HOLES IN CHORD & WEB ITEMS ARE 11/16" Ø
- 1" FROM ENDS AND/OR CENTERED RELATIVE TO ENDS.
- TOP CHORD SHALL BE HSS1-1/2x1-1/2x14GA. TUBE.
- BOTTOM CHORD SHALL BE HSS1-1/2x1-1/2x14GA. TUBE
- DIAGONAL WEB MEMBERS SHALL BE HSS1x1x14GA. TUBE.
- VERTICAL ENDS SHALL BE L1-1/2x1-1/2x3/16

8/17/22  
*[Signature]*

EOR: MICHAEL K. WEBER P.E.  
STRUCTURAL ENGINEER  
NORTH CAROLINA P.E. # 043557

EMBOSSED/ WET STAMP	DIGITAL
SCANNED AND ELECTRONICALLY TRANSMITTED COPIES OF THIS DOCUMENT ARE NOT CONSIDERED SIGNED AND SEALED SIGNATURE IS NOT CONSIDERED VALID WITHOUT THE PRESENCE OF BLUE INK	PRINTED COPIES OF THIS DOCUMENT ARE NOT CONSIDERED SIGNED AND SEALED AND THE SIGNATURE MUST BE VERIFIED ON THE ELECTRONIC COPIES

12'-50' HSS Tube Truss Drawings for: Blackwater Truss Systems 8736 Hwy 87 N. Milton, FL 32570	REV.	DESCRIPTION	DATE

JOB NUMBER: 22007-40  
DRAWN BY: DAW  
CHECKED BY: MKW  
PLOT DATE: 8/17/2022

**NOTE:**  
MAXIMUM STEP IN ROOF IS 14"  
BETWEEN LEAN-TO TRUSS &  
MAIN STRUCTURE DUE TO  
SNOW DRIFT REQUIREMENTS

SHEET TITLE  
12' LEAN-TO TRUSS PLAN  
DRAWING NUMBER  
**S113**