



ASM Engineering, PLLC

2248 Joel Rd.
Carthage, NC 28327
Phone: (910) 701-3070
scott@asmengineering.net
License # P-2502

October 2, 2023

Attn: Mr. Knight

Re: 158 Edgemont Terrace
Sanford, NC 27332
ASM# 23053

Dear Mr. Knight,

ASM Engineering, PLLC (ASM) performed an inspection at the above referenced site on September 14, 2023. The purpose of the site visit was to inspect the rafters on a newly covered back patio.

At the time of the inspection, the patio was covered and the framing was complete. The area of concern was the rafter depth size at the bearing location furthest away from the house (See Figure 2.0). According to the NC 2018 Residential Building Code, the required rafter depth at the outside bearing location is required to be a min. of 3-1/2" in depth (See Figure 3.0). The rafters were measured and found to exceed this min. depth of 3-1/2", and therefore meets the requirements of Chapter 8, from the NC 2018 Residential Building Code.

ASM attached pictures of the inspection in the following pages.

Thank you for this opportunity to serve you. Please contact ASM Engineering, PLLC. for any further information.

Sincerely,

A. Scott Matthews, PE
President

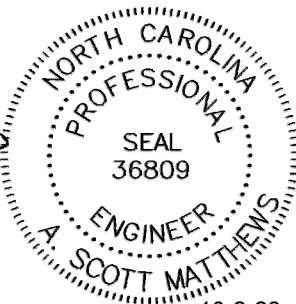

10-2-23



Covered Patio, view from back of the house.



Covered Patio, view from side of house.



View of rafters at outside bearing location.



Outside bearing location of the rafters (Figure 2.0).

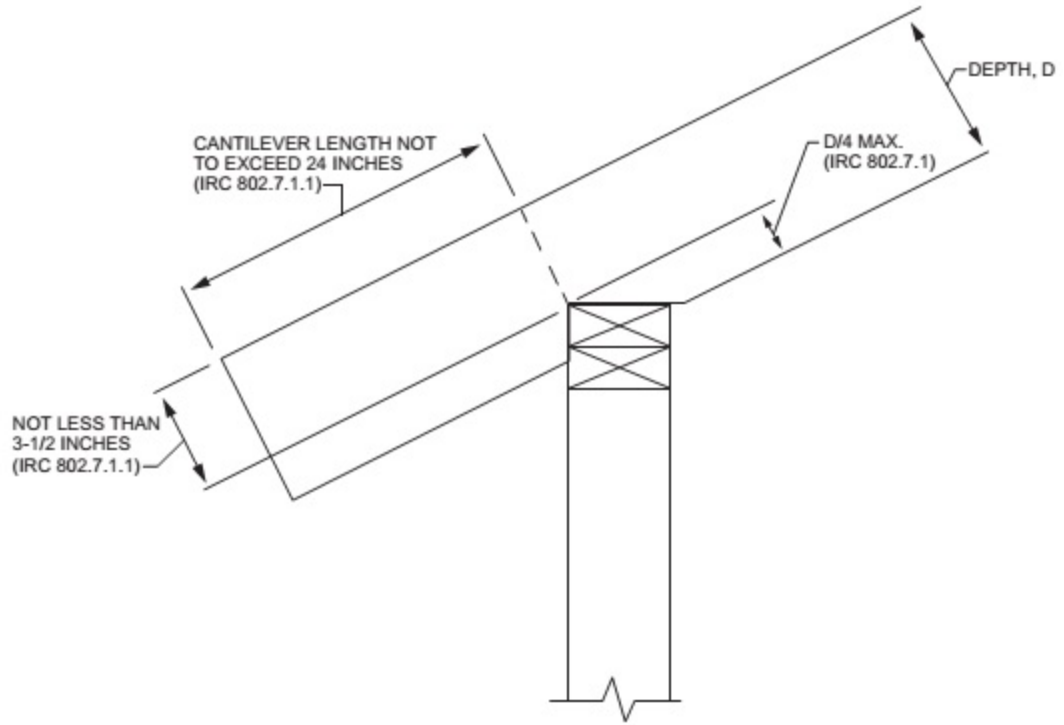

2018 Residential Building Code reference R802.7.1.1

(Figure 3.0)