

NOTES:

1. FASTEN TOGETHER WITH 3" HOT-DIPPED GALVANIZED NAILS (SCREW-SHANK).
2. STAIR / LANDING STRUCTURE IS DESIGNED TO BE SET DIRECTLY ON THE GROUND WITHOUT FOOTINGS UNDERNEATH.
3. REFER TO THE CURRENT EDITION OF THE "NC REGULATIONS FOR MANUFACTURED HOMES".
4. USE #2 PRIME TREATED WOOD.

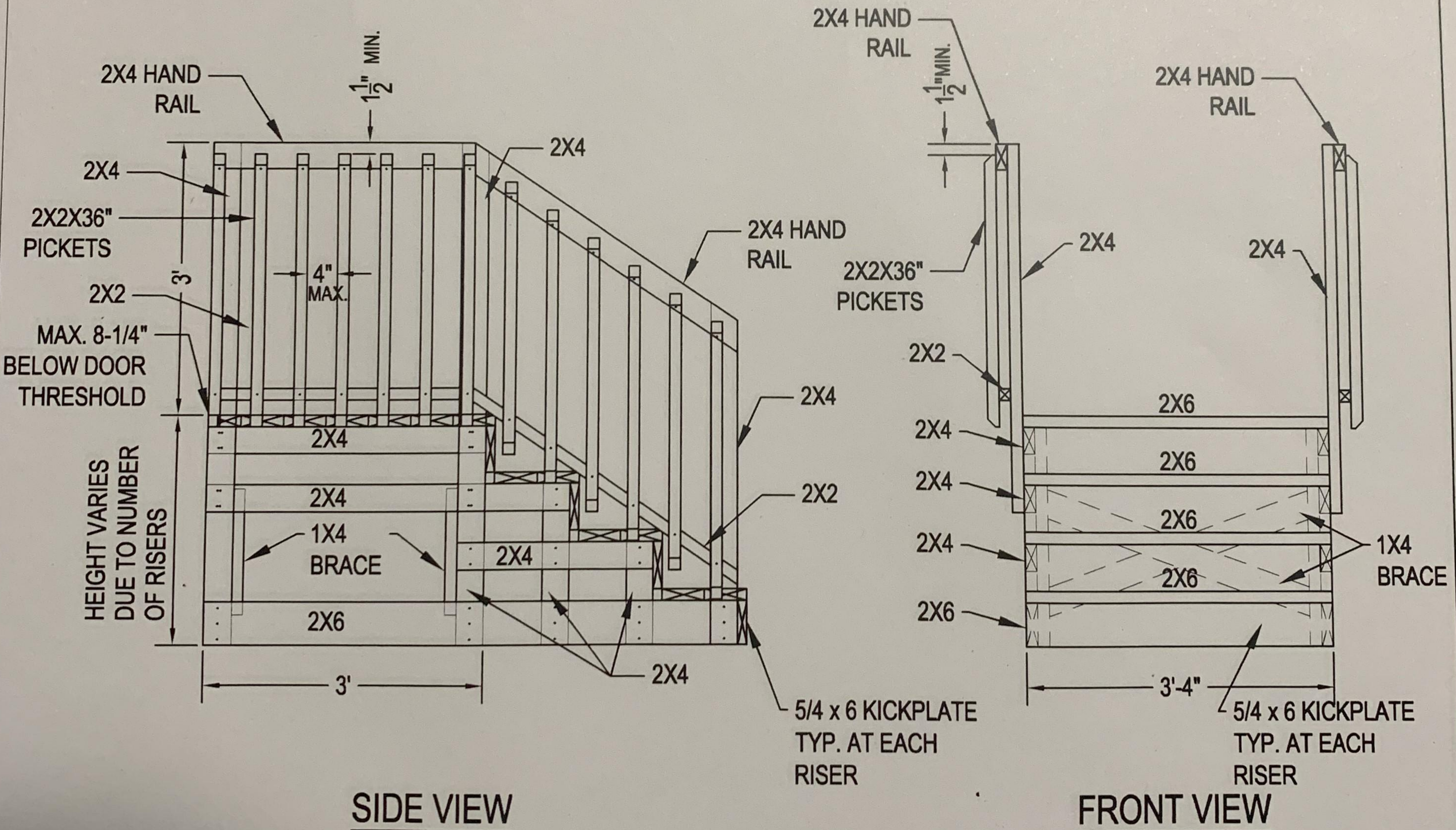

SIDE VIEW

FRONT VIEW

STAIR / PLATFORM DETAILS FOR

SOUTHEASTERN STEP & DECK, INC.

1907 EAST FIFTH STREET
LUMBERTON, N.C. 28358

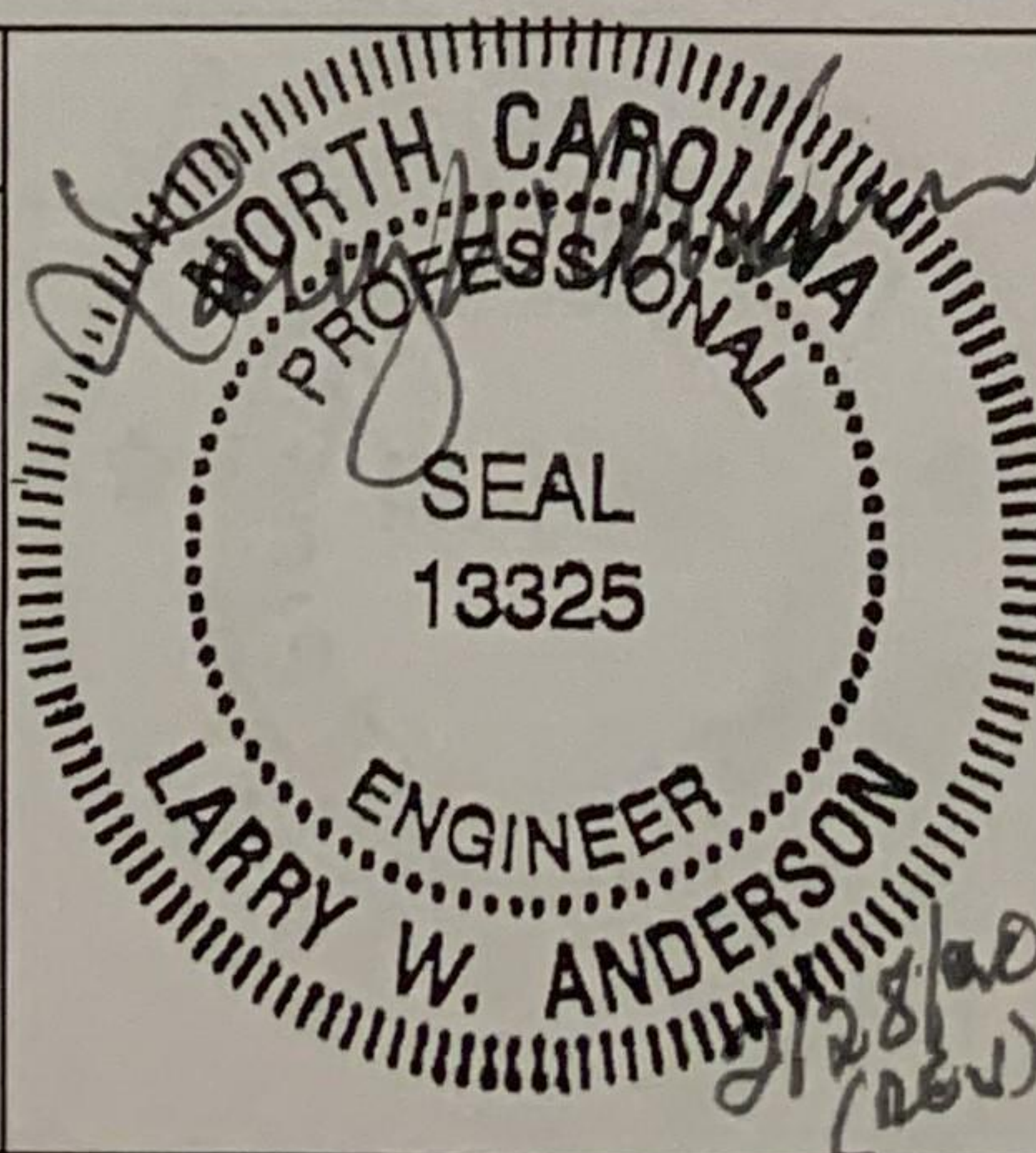

NO.	DATE	REVISION
1	2-19-2020	ADD KICKPLATES
2	2-28-2020	1x4 BRACE
PROJ. NO: S/E STEP		SCALE: 1/2"=1'
DWG. NO:		DWG. BY: DJ
DATE: 1-24-2020		APPROVED: LWA

SHEET NO. 1 OF 1

LARRY W. ANDERSON, PE.
305 N. Chippewa Street
Lumberton, NC 28358
Office: (910) 671-9530
Fax: (910) 618-0838
Email:
andersonengineeringpa@gmail.com
Licensure #: P.E. 13325 (NC.)
P.E. 11492 (SC.)