

Rickey & Susan Dotson
294 Village Bend Drive
Fuquay Varina, NC 27526

919-610-9772

Add in the shed door and optional window. Refer to double door and window plans for build details.

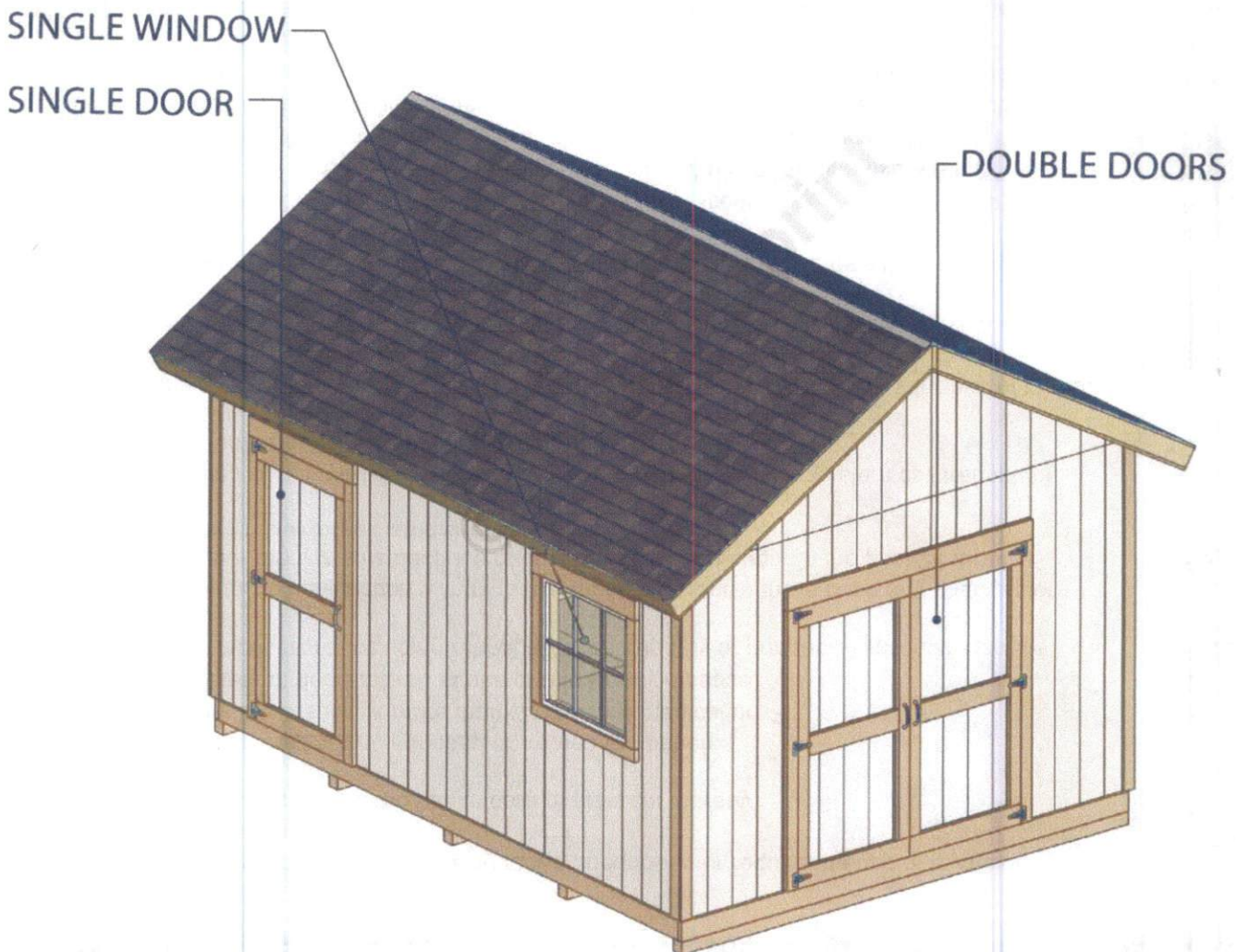

SEE DOOR AND WINDOW DETAILS

HEALTH QUESTIONNAIRE

Current Height _____

NAME _____

Current Weight _____

NOTICE TO APPLICANT: PLEASE ANSWER ALL OF THE FOLLOWING QUESTIONS in the Health Questions Sections. If any question in Section 1 is answered "YES", the applicant is not eligible for coverage. If any question(s) in Section 2 is answered "YES", the applicant may be eligible for coverage. Please verify the accuracy and completeness of the health information on this application. Incomplete or false information could jeopardize future claims.

HEALTH QUESTIONS SECTION # 1

.....IF ANY QUESTION 1-8 IS ANSWERED "YES", THE APPLICANT IS NOT ELIGIBLE FOR COVERAGE.....

- 1. Are you currently:
A. Hospitalized confined to a nursing facility, bedridden or require the use of a wheelchair or motorized mobility aid? YES NO
B. Receiving hospice, home health care or physical therapy? YES NO
2. Have you ever been medically diagnosed or treated for diabetes:
A. That requires insulin or more than (2) two oral medications? YES NO
B. With history of heart attack, stroke or any kidney disease? YES NO
C. With complications including retinopathy, neuropathy or peripheral vascular disease? YES NO
3. If you have diabetes in conjunction with high blood pressure, have there been any changes or adjustments in your medications because of uncontrolled blood sugar in the past 24 months? (If you do not have diabetes this question should be answered "NO") YES NO
4. Have you ever had or been advised to have any bone marrow transplant, stem cell transplant, an organ transplant or any amputation caused by disease? YES NO
5. At any time have you been medically diagnosed with, treated for, or had surgery for any of the following:
A. Alzheimer's disease, senile dementia, or any other cognitive disorder? YES NO
B. Emphysema, chronic obstructive pulmonary disease (COPD), sarcoidosis, or any pulmonary condition treated with supplemental oxygen or a nebulizer? YES NO
C. Parkinson's disease, multiple sclerosis, amyotrophic lateral sclerosis (Lou Gehrig's disease), muscular dystrophy or cerebral palsy? YES NO
D. Lupus, scleroderma, myasthenia gravis or Paget's disease? YES NO
E. Osteoporosis with fracture(s), crippling/disabling arthritis or rheumatoid arthritis? YES NO
F. Chronic hepatitis, cirrhosis of the liver, Crohn's disease or ulcerative colitis? YES NO
G. Retinopathy, wet macular degeneration or any eye condition that required injection(s)? YES NO
H. Addison's disease, Hodgkin's Disease, kidney failure or ever had kidney dialysis? YES NO
I. Congestive heart failure or a cardiac defibrillator? YES NO
J. Lymphoma, leukemia, multiple myeloma or more than (1) one occurrence of internal cancer? YES NO
K. Acquired immune deficiency syndrome (AIDS), AIDS related complex (ARC), or human immunodeficiency virus (HIV) infection? YES NO
6. Within the past (5) five years, have you been treated for, or been advised to have treatment for;
A. Hepatitis C, alcoholism, drug abuse, or had a mental or nervous disorder requiring a hospital confinement? YES NO
B. Any condition that resulted in chemotherapy or radiation treatments? YES NO
C. Osteopenia, Osteoporosis or any Arthritic condition whereas treatment included infusions(s) or injection(s)? YES NO
7. Within the past (2) two years, have you been treated for, or been advised to have treatment for:
A. Heart attack, cardiomyopathy, an enlarged heart, Stroke or transient ischemic attack (TIA)? YES NO
B. Coronary bypass surgery, heart valve surgery, aneurysm, angioplasty, or vascular surgery including stent(s) placement and or artery blockage? YES NO
C. Heart rhythm disorder, Atrial fibrillation (AFIB) or have you had a pacemaker implanted? YES NO
D. Any form of Internal cancer or melanoma? YES NO

Rickey Dotson

294 Village Bend Dr.
Fog way Varina NC 27526

919-610-9772

STEP 1 - FOUNDATION AND FLOOR

Start with selecting a proper site for the shed foundation, ideally a flat solid surface away from any large trees.

The first step is cut ten 2x6 lumbers to 15'-9" length, and two 2x6 lumbers to 12'-0". Next, place the five 12' 4x4 lumbers parallel to each other at 48" apart. Then, assemble the 2x6 perimeter frames on top, this will outline the overall floor frame. Drill pilot holes through the joists and secure with 3 1/2" screws. Finally, install the eight 2x6 floor joists at 16" O.C. to complete the foundation.

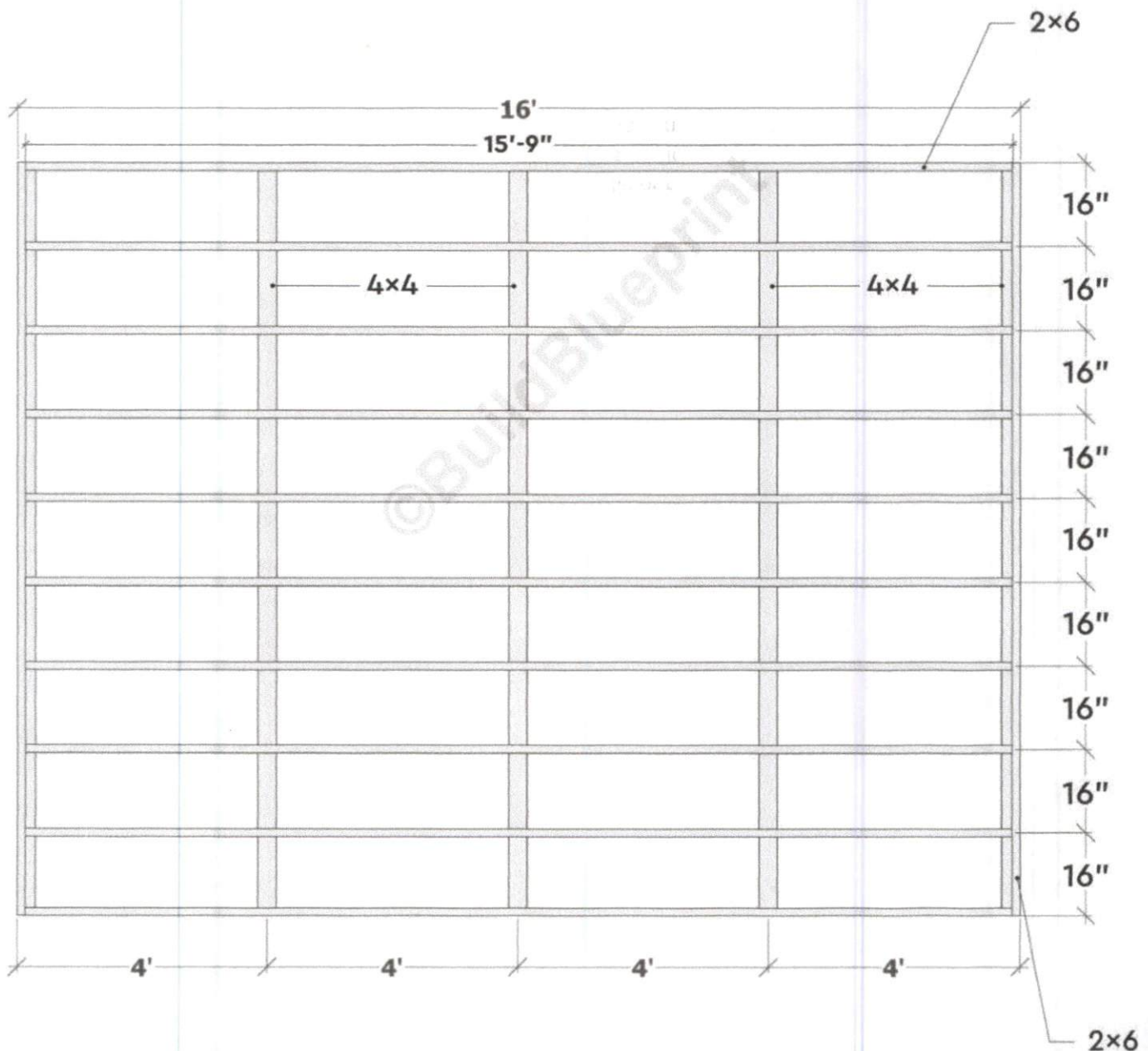

FLOOR FRAMING PLAN

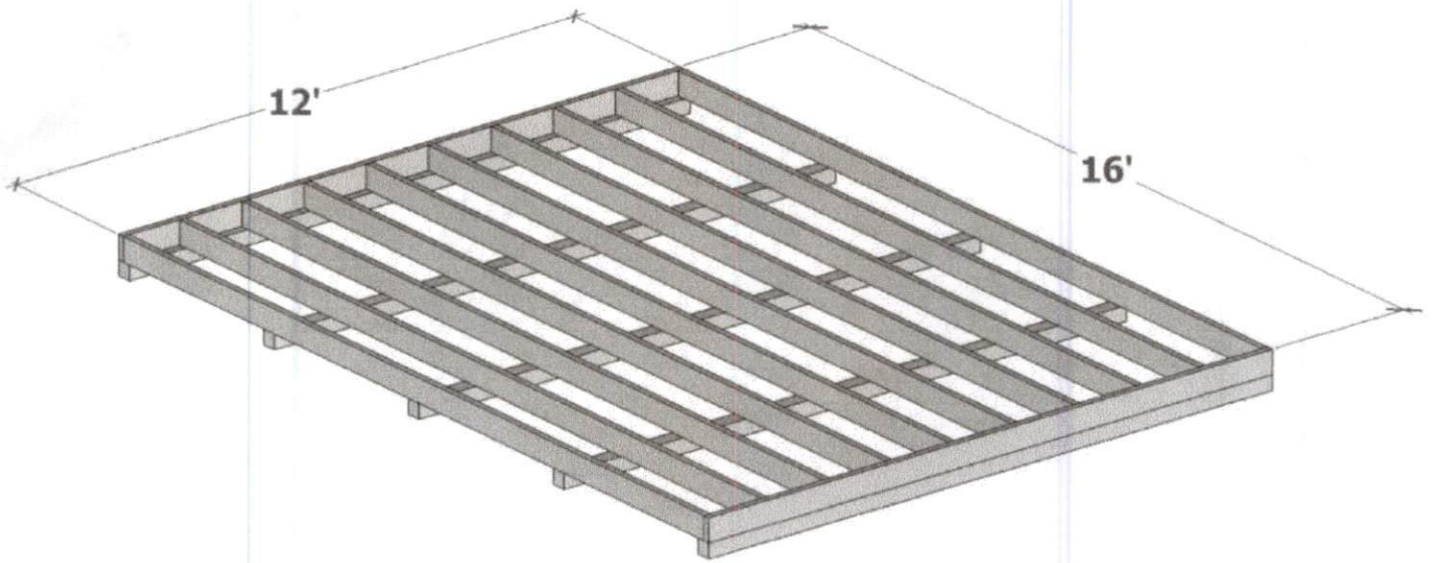

After the floor frame is secured, cut the tongue and groove 23/32" plywood to size and attach to the frame. You'll need 6 full sheets to cover the 192SF floor area. These sheets usually come in standard sizes of 48" x 96". Insert 2" deck screws every 8" along the joint, don't leave any gaps between the sheets. Refer to the cut pattern below:

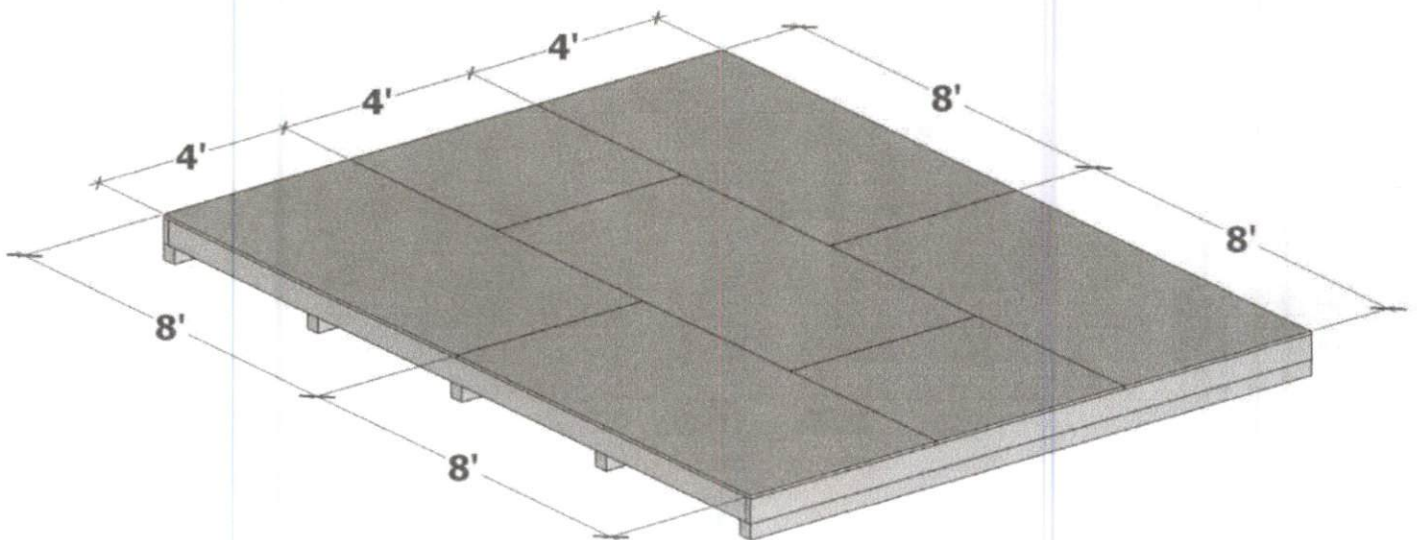

STEP 3 – ROOF

The roof will require a total of 10 identical gable kingpost style trusses, installed 20" O.C. There are also two cross bracing placed on both ends for added stability. The trusses are designed to have an overhang of 10" on both sides. Refer to the truss detail page for dimensions and assembly instructions.

Tip: make 1 truss first and make sure everything fits in place.

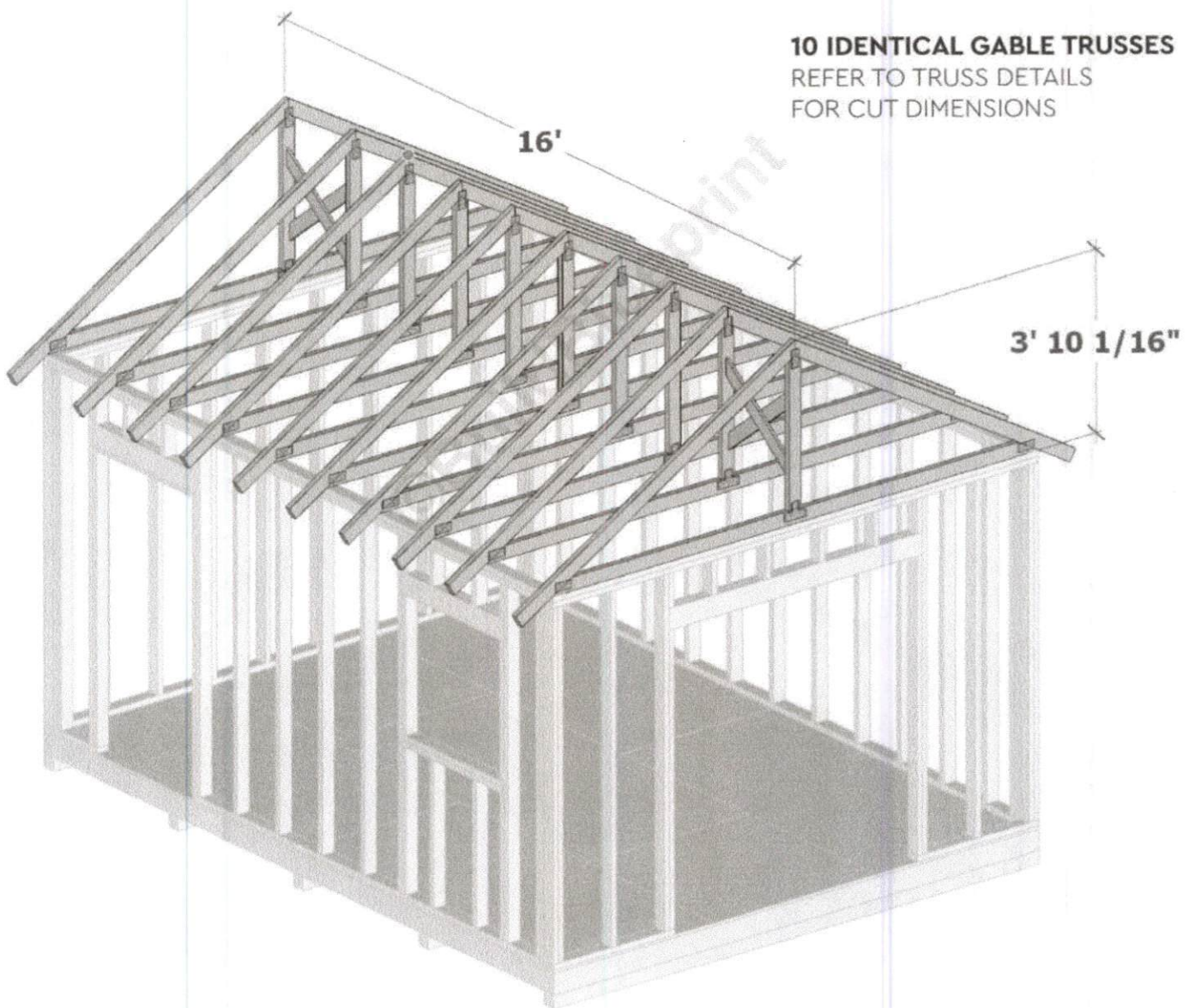

Now that all 4 wall frames are done, time to put them together!

First, line up the edges of the front and side wall frame with the floor frame perimeter. Make sure edges line up and there's no gaps, use a spirit level if needed. Then, drill pilot holes through the bottom wall plate, and insert 3 ½" screws to secure wall frame to the floor. After both wall frames are secured, lock the adjacent walls together by inserting 3 ½" screws or nails.

Repeat and assemble all 4 wall frames.

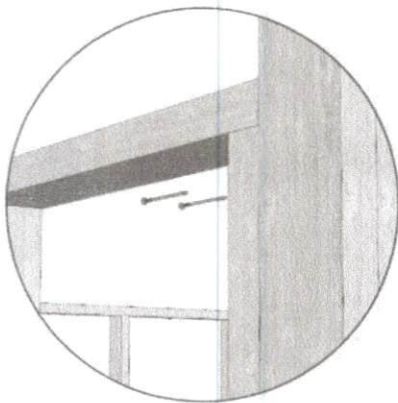

Assemble and secure frames with 3 ½" nails

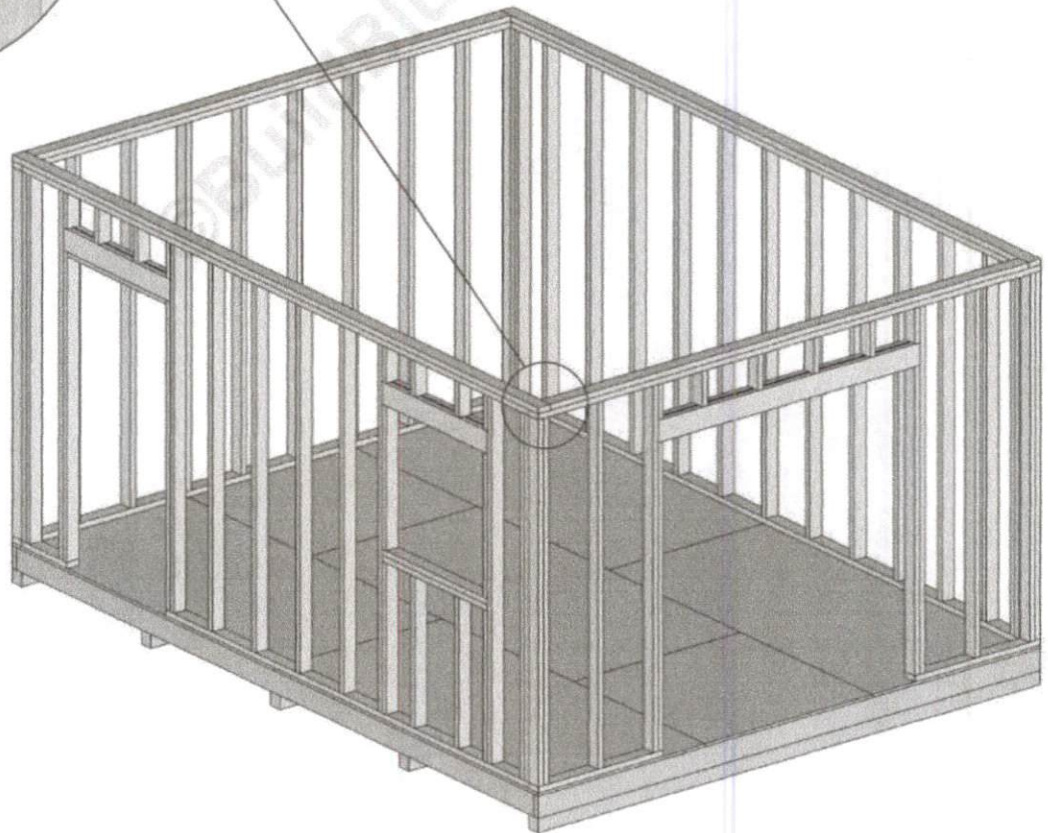

The east side wall is built with 15 2x4 wall studs at 7'-5 3/4" length, spaced 16" apart on center. The top and bottom plates are 15'-5" 2x4's, with the double top plate at 16'-0". Drill pilot holes through the plate and insert 3 1/2" screws to secure the studs.

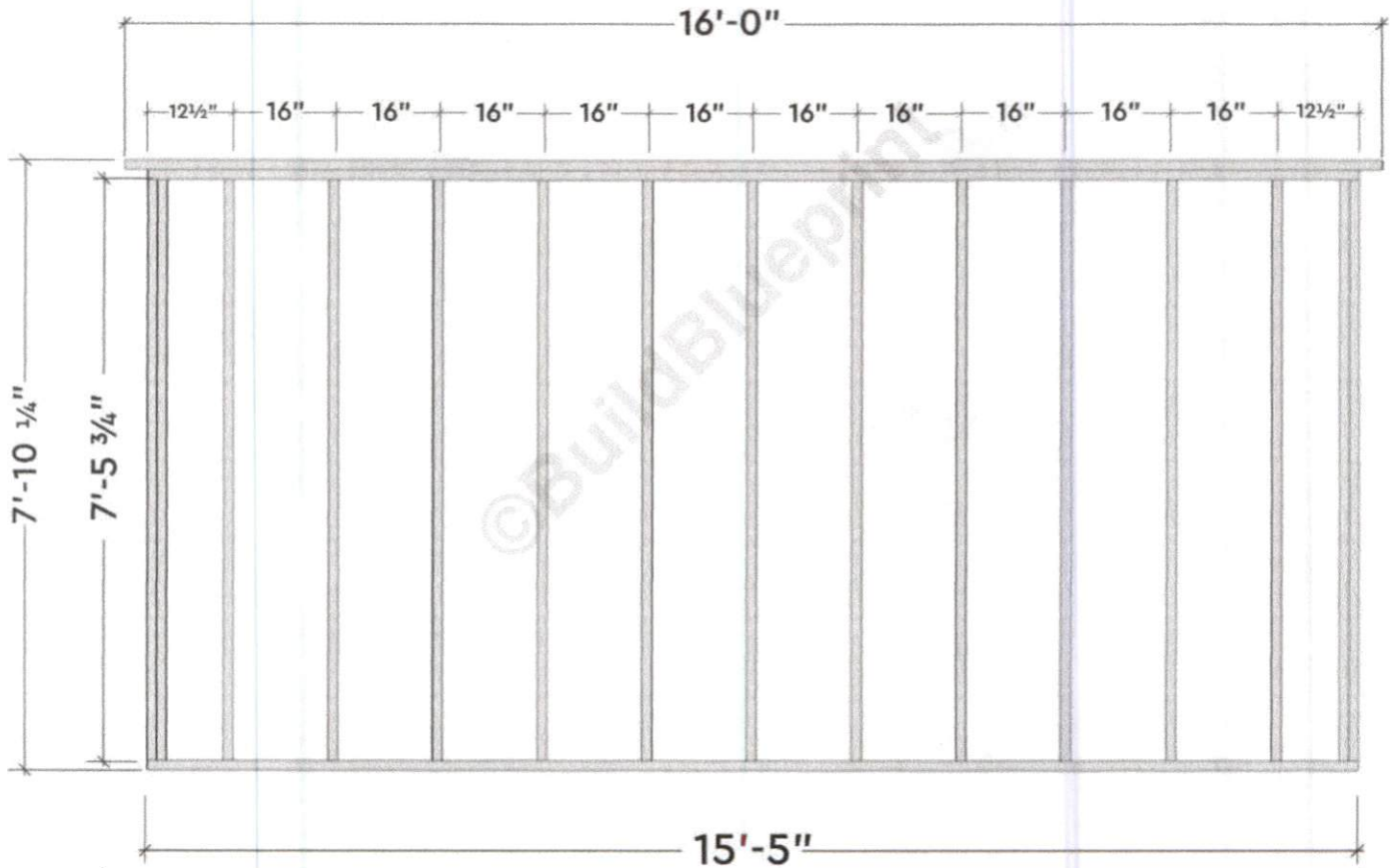

EAST SIDE WALL FRAMING

Continue the build by assembling the 2 side wall frames. Cut two 2 x 4's lumber to 15'-5" as top and bottom plate, then a full 16' 2 x 4 as the double top plate. then cut 12 2 x 4's to 7'-5 3/4" for the wall studs. The single door studs are 6'-3 1/2" in length.

See door and window detail for detailed build dimensions.

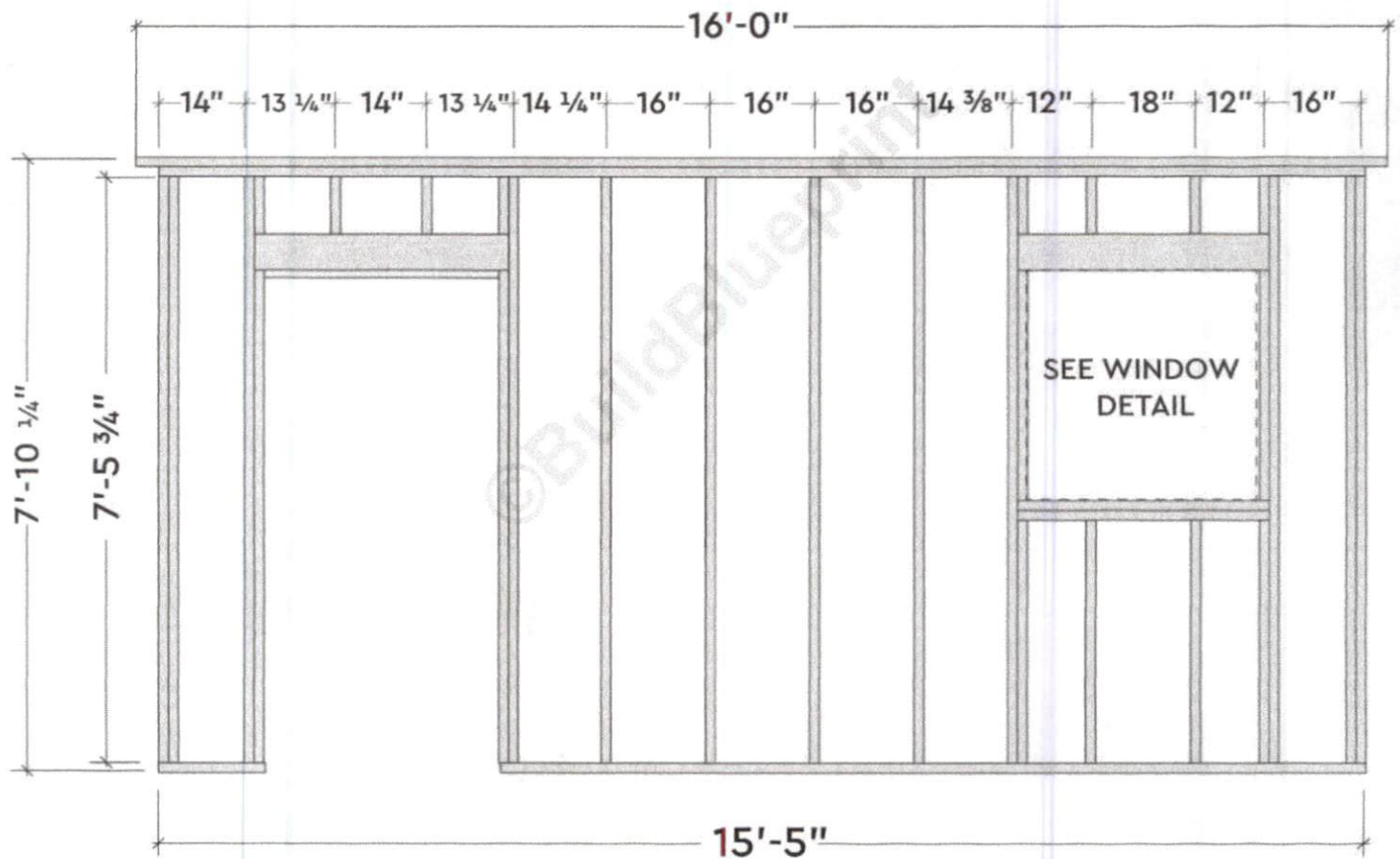

WEST SIDE WALL FRAMING

\$4.96

\$4.96

\$1.24

\$4.15

Oxycodone-acetaminophen 5-325mg tablet

\$7.70

\$7.70

\$1.69

\$1.93

\$4.15

Prasugrel hci 10mg tablet

\$67.10

\$67.10

\$14.76

\$16.78

\$4.15

Prednisone 5mg tablet

\$7.25

Next up is the building up the shed's back wall. Cut two 2 x 4's to 12' length, and 12 more 2 x 4's to 7'-5 3/4" length. Then cut out a 11'-5" 2 x 4 as the double top plate. Follow the framing plan below.

Space the wall studs to 16" O.C. matching the width of the front wall frame. Drill pilot holes through the plate and insert 3 1/2" screws to secure the studs.

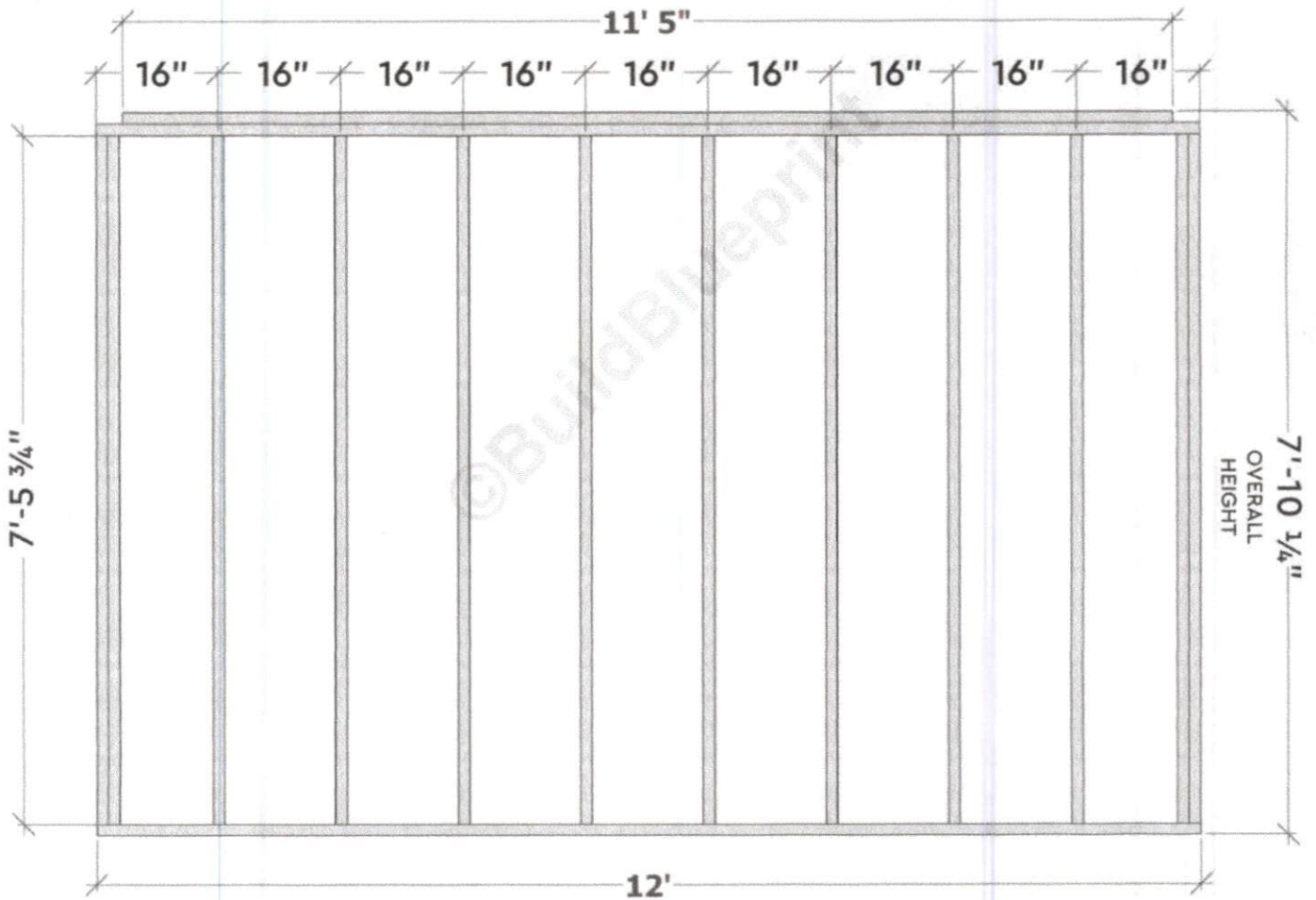

REAR WALL FRAMING

Escitalopram oxalate 20mg tablet

\$12.20

\$12.20

\$12.20

\$3.05

\$4.15

Fentanyl 50mcg/hr patch 72 hour

\$74.45

\$74.45

\$36.48

\$18.61

\$4.15

Furosemide 20mg tablet

\$2.30

\$2.30

\$2.30

\$0.58

\$2.30

To construct the door header, cut two 2 x 6 lumber to 6'-3" length, and insert 1/2" plywood as filler. Use wood glue and 3 1/2" nails to secure all the pieces together.

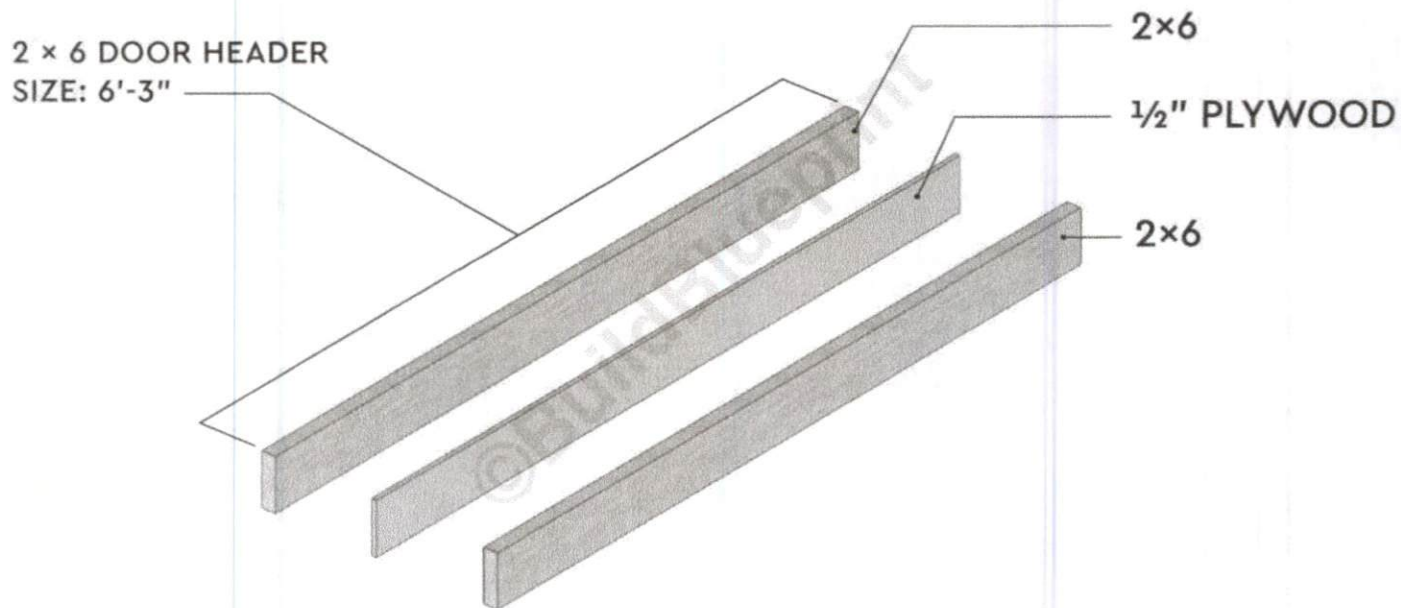

\$7.25

\$1.81

\$4.15

Repatha pushtronex system 420mg/3.5ml solution cartridge

\$625.57

\$625.57

\$137.63

\$156.39

\$31.28

Tizanidine hcl 4mg tablet

\$11.30

\$11.30

\$11.30

\$2.83

\$4.15

Monthly totals

\$865.44

\$852.83

STEP 4 – EXTERIOR SIDINGS

Next up is installing the exterior shed sidings, it's easier to do this first before adding in the roof trims.

Measure and cut 16 T1-11 plywood siding panels to size. These shed panels are designed to interlock, so plan them out accordingly. These siding panels also come in standard sizes of 96" x 48", you'll need about 496SF to cover the entire shed.

For the front wall siding, measure and cut out the door and window openings before installing. The rough double door opening is 72" x 77", rough opening for single door is 36" x 77", and the optional window opening is 2'-11 1/4" x 2'-11 3/8".



L

LATCH

M

Assorted fasteners

(estimate)

25.00

Grand Total

Print this list out and take it down to your local building supply store to calculate the cost of building this 12x12 shed. Use the notes below for additional information on the items you need.

Materials notes for 12x12 gable roof shed plans:

FREE download:

- [Click here to download a 28 page PDF that includes materials lists and cost estimate worksheets for all my shed and garage plans.](#)

Compare these 12x12 gable shed plans with my 3 other styles of 12x12 shed plans:

Share this:



Buy All 4
Shed Plans
For Only
\$27.95



\$27.95

TRUSS DETAIL

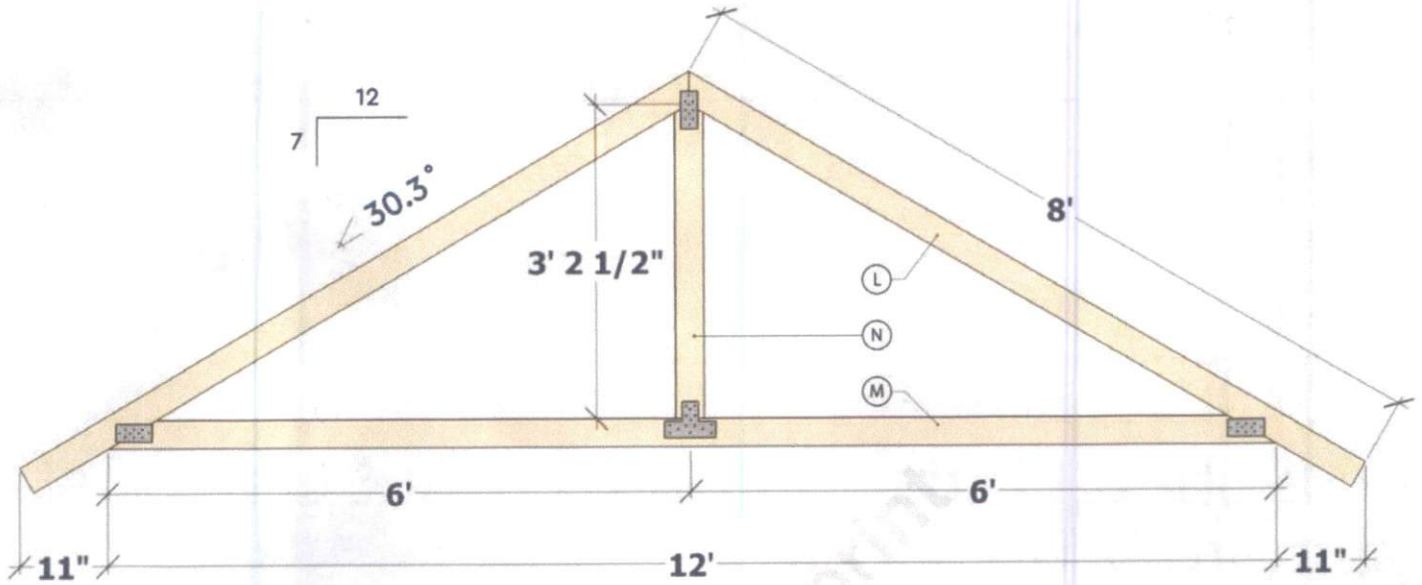

GABLE TRUSS DETAIL

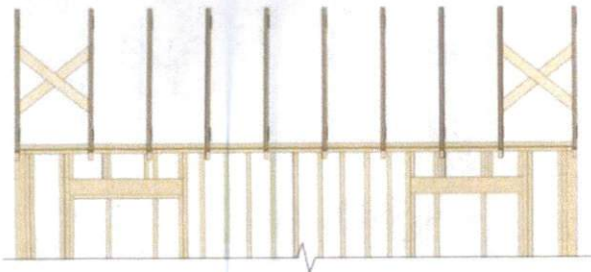

ROOF BRACING SECTION VIEW

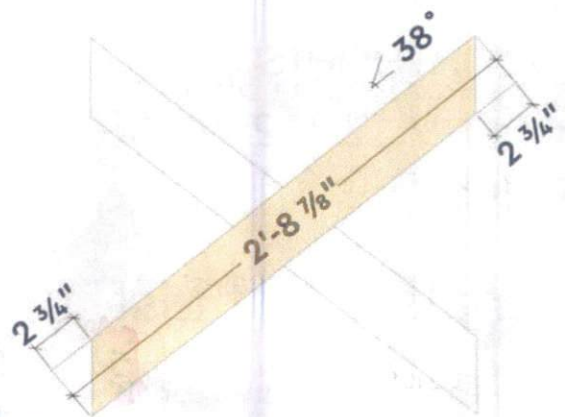

ROOF BRACING DETAIL

\$9.97 TALL BARN PLANS

\$7.95 PLANS

\$9.95 DELUXE PLANS

\$11.95 LEAN TO PLANS

\$19.95 GARAGE PLANS

12x12 Shed Plans, Materials & Cut List, Cost Estimate Worksheet

In addition to the 12x12 Gable shed plans I offer these 3 other styles of 12x12 shed plans:

- 12x12 Deluxe gable shed plans
- 12x12 Gambrel barn shed plans
- 12x12 Lean to single slope shed plans

This materials & cut list and cost estimate worksheet is for my 12x12 gable roof shed plans with these features:

Materials & Cut List, 12x12 Gable Shed Plans

- Click here to download a 28 page PDF that includes materials lists and cost estimate worksheets for all my shed and garage plans.

Notes

Item: Cut dimensions, Table 2

Size

Quantity

TRUSS DETAIL

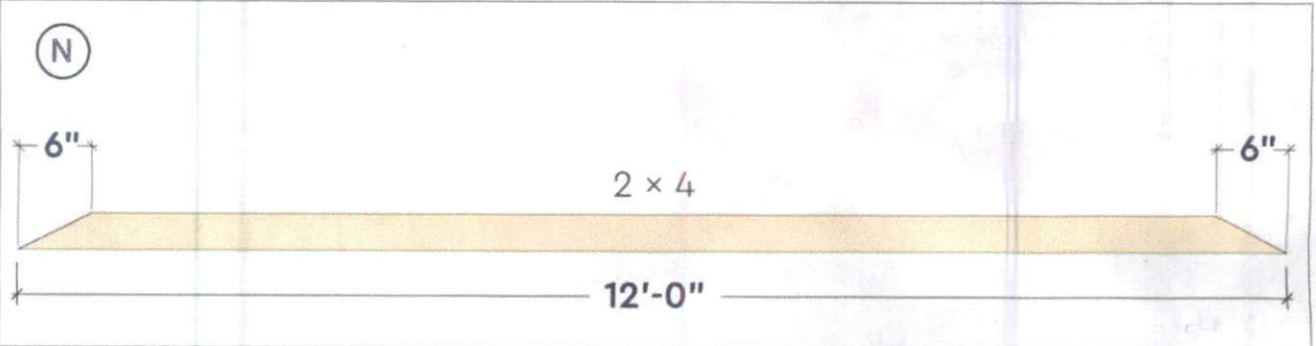
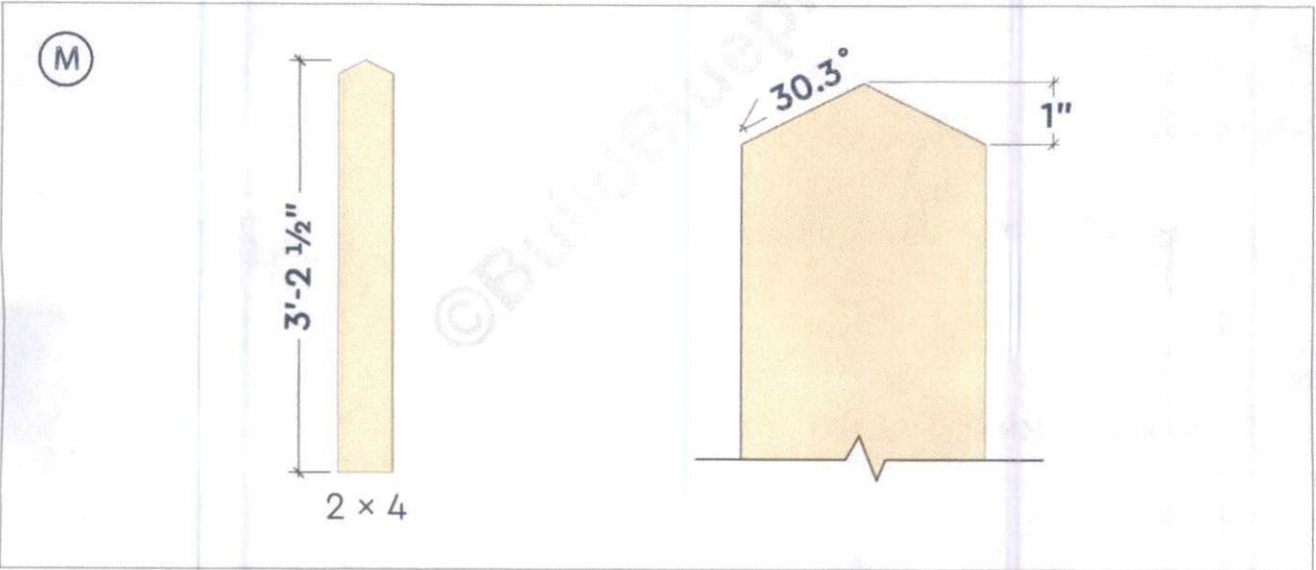
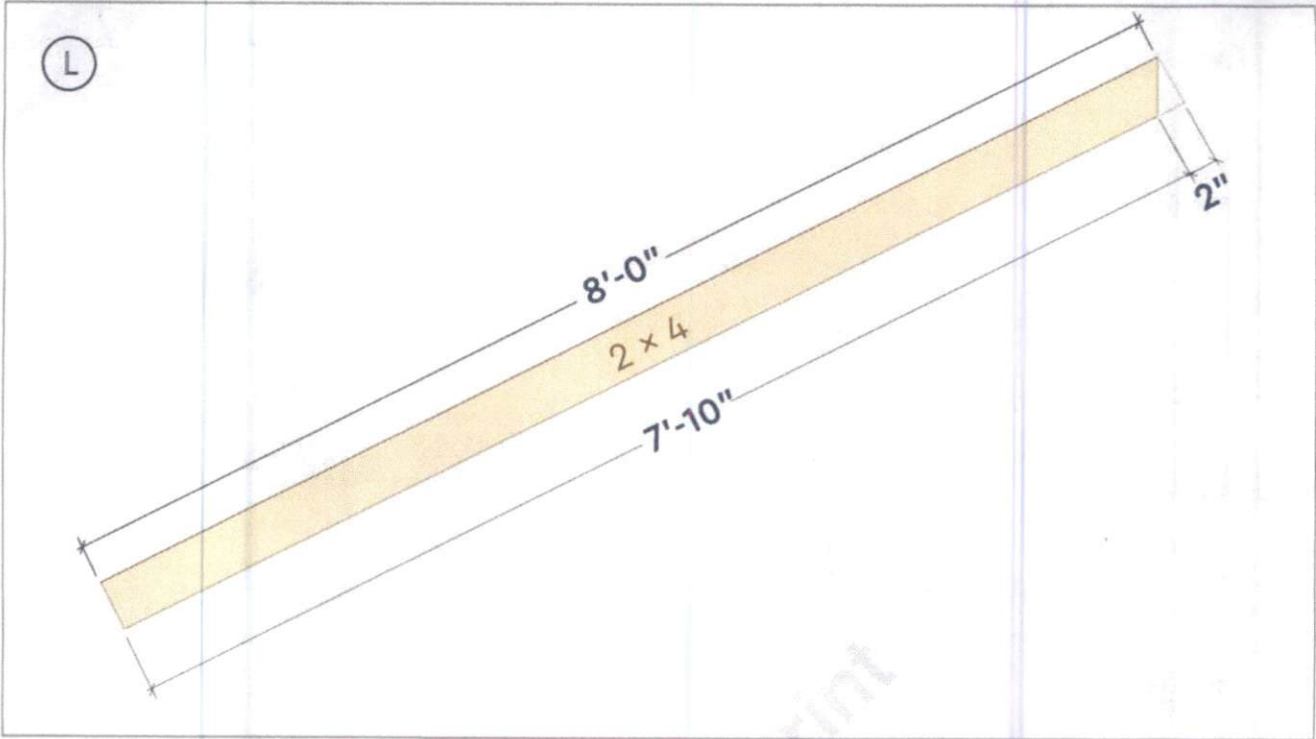

TRUSS MEMBER CUTS

BUY PLANS

RESOURCES

FORUM

FAQ'S

REFUNDS

CONTACT

A

Pressure treated studs. D

5k:ds

4x4x12ft
4x4x12

2

Floor

Band boards: B

2x6x12ft

2

Floor joists: C

2x6x12ft

10

F

Floor sheeting, 3/4in plywood or OSB

4ftx8ft

5

12ft Side wall #1

Top & bottom plates: E

2x4x12ft

2

B

Studs: Figure 4b

2x4x92 5/8

7

D

Siding, 7/16 to 5/8inch

4ftx8ft

3

12ft Side wall #2

Top & bottom plates: E

2x4x12ft

2

B

Studs: Figure 4b

2x4x92 5/8

7

D

Siding, 7/16 to 5/8inch

4ftx8ft

3

12ft End wall #1

Top & bottom plates: A

2x4x12ft

2

B

Studs: Figure 4a

2x4x92 5/8

7

D

Siding, 7/16 to 5/8 inch

4ftx8ft

3

12ft End wall #2

Top & bottom plates: A

2x4x12ft

2

After all the purlins are secured in place, measure and cut the 3/4" plywood panels to size. These sheets usually come in standard 96" x 48" size, you'll need about 295SF to cover the entire roof area. Insert 2 1/2" nails into the purlins at about every 10" to lock the plywood sheets in place.

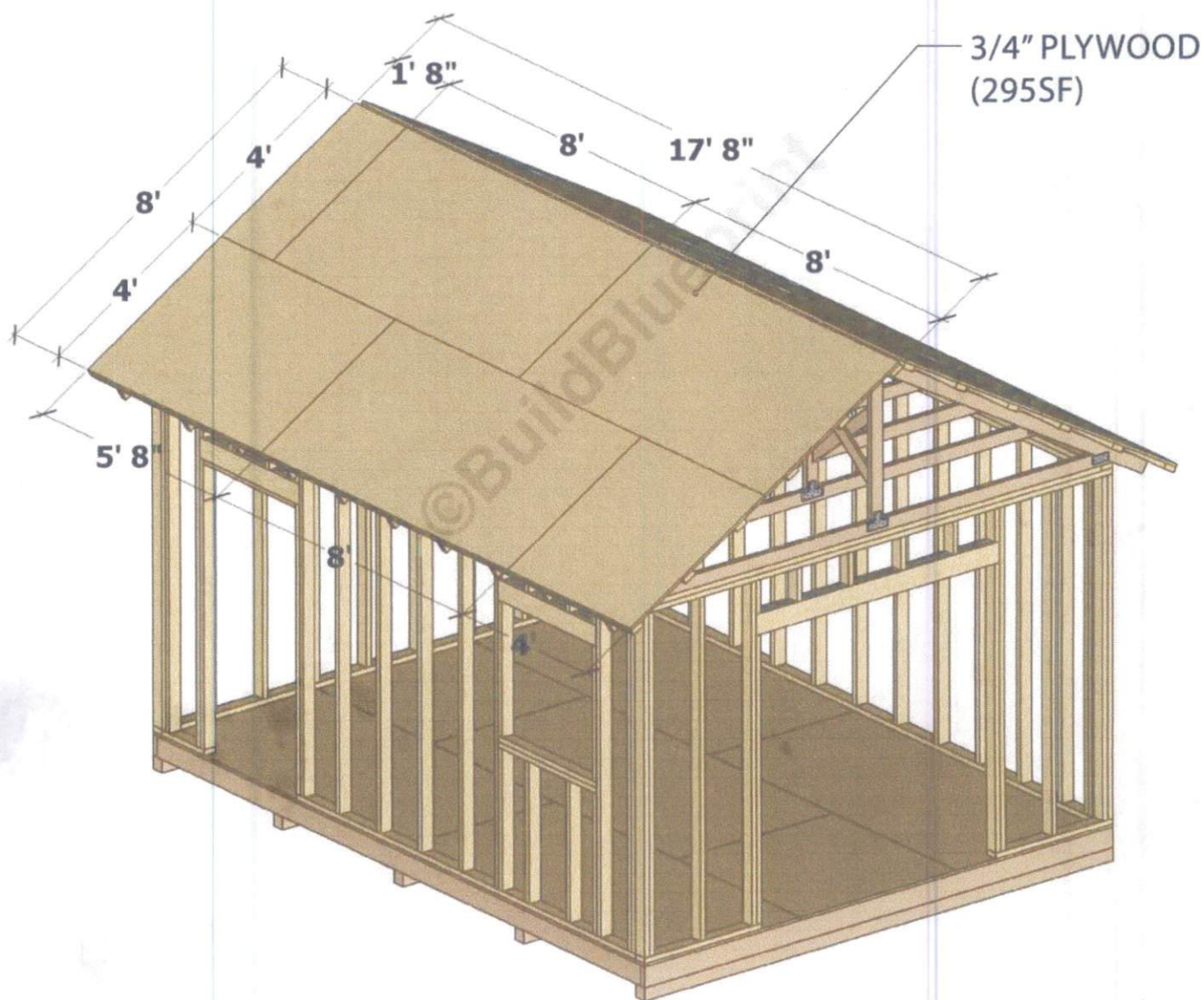

12/29/22, 7:39 AM

Gmail - Receipt for Your Payment to Progressive Direct Insurance

Not sure why you received this email? [Learn more](#)

Copyright © 1999-2022 PayPal, Inc. All rights reserved. PayPal is located at 2211 N. First St., San Jose, CA 95131.

PayPal RT000016:en_US(en-US):1.5.0:7483377ba6234