



STRUCTURAL DESIGN



ENCLOSED BUILDING

MAXIMUM 30'-0" WIDE X 20'-0" EAVE HEIGHT-
BOX EAVE FRAME AND BOW FRAME

21 March 2022
Revision 1
M&A Project No. 19164S/22020S

Prepared for:

TOL Buildings, Inc.
P.O. Box 542
Toast, NC 27049

Prepared by:

Moore and Associates Engineering and Consulting, Inc.
1009 East Avenue
North Augusta, SC 29841

401 S. Main Street, Suite 200
Mt. Airy, NC 27030



MOORE AND ASSOCIATES
ENGINEERING AND CONSULTING

Moore and Associates Engineering and Consulting, Inc. ("Moore & Associates") is the author and owner of all plans, drawings, specifications, etc. ("Instruments of Service") provided by it, and retains all common law, statutory, and other reserved rights, including without limitation copyrights. A limited license is granted to you for use of the Instruments of Service solely and exclusively in connection with the specific project for which the Instruments of Service were created by Moore & Associates. All other uses, including without limitation transfer to a third party, are strictly prohibited. Acceptance of the Instruments of Service constitutes your agreement to indemnify and to hold Moore & Associates harmless from all cost, expenses, damages, and attorney's fees arising from or relating to any unauthorized use or transfer of the Instruments of Service.

<p>MOORE AND ASSOCIATES ENGINEERING AND CONSULTING, INC.</p>		<p>DRAWN BY: LT</p> <p>CHECKED BY: PDH</p>		<p>TOL BUILDINGS, INC. P.O. BOX 542 TOAST, NC 27049 30'-0" x 20'-0" ENCLOSED STRUCTURE</p>	
<p>THIS DOCUMENT IS THE PROPERTY OF MOORE AND ASSOCIATES ENGINEERING AND CONSULTING. THE UNAUTHORIZED REPRODUCTION, COPYING, OR OTHERWISE USE OF THIS DOCUMENT IS STRICTLY PROHIBITED AND ANY INFRINGEMENT THEREUPON MAY BE SUBJECT TO LEGAL ACTION.</p>		<p>PROJECT MGR: VSH</p>	<p>DATE: 3-21-22</p>	<p>SCALE: NTS</p>	<p>JOB NO: 19164S/22020S</p>
		<p>CLIENT: TOL</p>	<p>SHT. 1</p>	<p>DWG. NO: SK-3</p>	<p>REV: 1</p>

DRAWING INDEX

SHEET 1	PE SEAL COVER SHEET
SHEET 2	DRAWING INDEX
SHEET 2A	DRAWING INDEX
SHEET 3	INSTALLATION NOTES AND SPECIFICATIONS
SHEET 3A	LIST OF APPLICABLE BUILDING CODES
SHEET 4	TYPICAL END AND SIDE ELEVATIONS
SHEET 5	TYPICAL RAFTER/COLUMN END FRAMING SECTIONS (BOX EAVE RAFTER) 60 PSF < SL < 70 PSF EXPOSURE B
SHEET 5A	TYPICAL RAFTER/COLUMN END AND SIDE FRAMING SECTION (BOX EAVE RAFTER) 60 PSF < SL < 70 PSF EXPOSURE B
SHEET 5B	TYPICAL RAFTER/COLUMN END FRAMING SECTION (BOX EAVE RAFTER) 60 PSF < SL < 70 PSF EXPOSURE C
SHEET 5C	TYPICAL RAFTER/COLUMN END AND SIDE FRAMING SECTION (BOX EAVE RAFTER) 60 PSF < SL < 70 PSF EXPOSURE C
SHEET 5D	TYPICAL RAFTER/COLUMN END AND SIDE FRAMING SECTION (BOX EAVE RAFTER) SL < 60 PSF EXPOSURE B/C
SHEET 5E	TYPICAL RAFTER/COLUMN END AND SIDE FRAMING SECTION (BOX EAVE RAFTER) SL < 60 PSF EXPOSURE B/C
SHEET 5F	TYPICAL RAFTER/COLUMN END AND SIDE FRAMING SECTION (BOX EAVE RAFTER) SL < 30 PSF EXPOSURE B/C
SHEET 6	RAFTER/COLUMN CONNECTION DETAILS (BOX EAVE RAFTER) (60 PSF < SL < 70 PSF EXPOSURE B)
SHEET 6A	RAFTER/COLUMN CONNECTION DETAILS (BOX EAVE RAFTER) (60 PSF < SL < 70 PSF EXPOSURE B)
SHEET 6B	RAFTER/COLUMN CONNECTION DETAILS (BOX EAVE RAFTER) (60 PSF < SL < 70 PSF EXPOSURE B)
SHEET 6C	RAFTER/COLUMN CONNECTION DETAILS (BOX EAVE RAFTER) (60 PSF < SL < 70 PSF EXPOSURE C)
SHEET 6D	RAFTER/COLUMN CONNECTION DETAILS (BOX EAVE RAFTER) (60 PSF < SL < 70 PSF EXPOSURE C)
SHEET 6E	RAFTER/COLUMN CONNECTION DETAILS (BOX EAVE RAFTER) (60 PSF < SL < 70 PSF EXPOSURE C)
SHEET 6F	RAFTER/COLUMN CONNECTION DETAILS (BOX EAVE RAFTER) (SL < 60 PSF EXPOSURE B/C)
SHEET 6G	RAFTER/COLUMN CONNECTION DETAILS (BOX EAVE RAFTER) (SL < 60 PSF EXPOSURE B/C)
SHEET 6H	RAFTER/COLUMN CONNECTION DETAILS (BOX EAVE RAFTER) (SL < 60 PSF EXPOSURE B/C)
SHEET 6J	RAFTER/COLUMN CONNECTION DETAILS (BOX EAVE RAFTER) (SL < 60 PSF EXPOSURE B/C)
SHEET 6K	RAFTER/COLUMN CONNECTION DETAILS (BOX EAVE RAFTER) (SL < 60 PSF EXPOSURE B/C)
SHEET 6L	RAFTER/COLUMN CONNECTION DETAILS (BOX EAVE RAFTER) (SL < 30 PSF EXPOSURE B/C)
SHEET 6M	RAFTER/COLUMN CONNECTION DETAILS (BOX EAVE RAFTER) (SL < 30 PSF EXPOSURE B/C)
SHEET 7	TYPICAL RAFTER/COLUMN END AND SIDE FRAMING SECTION (BOX EAVE RAFTER) 60 PSF < SL < 70 PSF EXPOSURE B
SHEET 7A	TYPICAL RAFTER/COLUMN END AND SIDE FRAMING SECTION (BOX EAVE RAFTER) 60 PSF < SL < 70 PSF EXPOSURE B
SHEET 7B	TYPICAL RAFTER/COLUMN END AND SIDE FRAMING SECTION (BOX EAVE RAFTER) 60 PSF < SL < 70 PSF EXPOSURE C

**MOORE AND ASSOCIATES
ENGINEERING AND CONSULTING, INC.**

DRAWN BY: LT

CHECKED BY: PDH

PROJECT MGR: WSH

CLIENT: TOL

TOL BUILDINGS, INC.

P.O. BOX 542

TOAST, NC 27049

30'-0"x20'-0" ENCLOSED STRUCTURE

DATE: 3-21-22

SCALE: NTS

**JOB NO
19164S/22020S**

SHT. 2

DWG. NO: SK-3

REV: 1

THIS DOCUMENT IS THE PROPERTY OF MOORE AND ASSOCIATES ENGINEERING AND CONSULTING. THE UNAUTHORIZED REPRODUCTION, COPYING, OR OTHERWISE USE OF THIS DOCUMENT IS STRICTLY PROHIBITED AND ANY INFRINGEMENT THEREUPON MAY BE SUBJECT TO LEGAL ACTION.

DRAWING INDEX

SHEET 7C	TYPICAL RAFTER/COLUMN END AND SIDE FRAMING SECTION (BOW EAVE RAFTER) 60 PSF < SL < 70 PSF EXPOSURE C
SHEET 7D	TYPICAL RAFTER/COLUMN END AND SIDE FRAMING SECTION (BOW EAVE RAFTER) SL < 60 PSF EXPOSURE B/C
SHEET 7E	TYPICAL RAFTER/COLUMN END AND SIDE FRAMING SECTION (BOW EAVE RAFTER) SL < 60 PSF EXPOSURE B/C
SHEET 7F	TYPICAL RAFTER/COLUMN END AND SIDE FRAMING SECTION (BOW EAVE RAFTER) SL < 30 PSF EXPOSURE B/C
SHEET 8	RAFTER/COLUMN CONNECTION DETAILS (BOX EAVE RAFTER) (60 PSF < SL < 70 PSF EXPOSURE B)
SHEET 8A	RAFTER/COLUMN CONNECTION DETAILS (BOX EAVE RAFTER) (60 PSF < SL < 70 PSF EXPOSURE B)
SHEET 8B	RAFTER/COLUMN CONNECTION DETAILS (BOX EAVE RAFTER) (60 PSF < SL < 70 PSF EXPOSURE B)
SHEET 8C	RAFTER/COLUMN CONNECTION DETAILS (BOX EAVE RAFTER) (60 PSF < SL < 70 PSF EXPOSURE C)
SHEET 8D	RAFTER/COLUMN CONNECTION DETAILS (BOX EAVE RAFTER) (60 PSF < SL < 70 PSF EXPOSURE C)
SHEET 8E	RAFTER/COLUMN CONNECTION DETAILS (BOX EAVE RAFTER) (60 PSF < SL < 70 PSF EXPOSURE C)
SHEET 8F	RAFTER/COLUMN CONNECTION DETAILS (BOX EAVE RAFTER) (SL < 60 PSF EXPOSURE B/C)
SHEET 8G	RAFTER/COLUMN CONNECTION DETAILS (BOX EAVE RAFTER) (SL < 60 PSF EXPOSURE B/C)
SHEET 8H	RAFTER/COLUMN CONNECTION DETAILS (BOX EAVE RAFTER) (SL < 60 PSF EXPOSURE B/C)
SHEET 8J	RAFTER/COLUMN CONNECTION DETAILS (BOX EAVE RAFTER) (SL < 60 PSF EXPOSURE B/C)
SHEET 8K	RAFTER/COLUMN CONNECTION DETAILS (BOX EAVE RAFTER) (SL < 60 PSF EXPOSURE B/C)
SHEET 8L	RAFTER/COLUMN CONNECTION DETAILS (BOX EAVE RAFTER) (SL < 30 PSF EXPOSURE B/C)
SHEET 8M	RAFTER/COLUMN CONNECTION DETAILS (BOX EAVE RAFTER) (SL < 30 PSF EXPOSURE B/C)
SHEET 9	BASE RAIL ANCHORAGE OPTIONS WITH ATTACHED LEAN-TO
SHEET 9A	BASE RAIL ANCHORAGE OPTIONS WITHOUT ATTACHED LEAN-TO
SHEET 9B	BASE RAIL ANCHORAGE OPTIONS
SHEET 10	TYPICAL END WALL AND SIDE WALL FRAMING SECTIONS (BOX EAVE RAFTER)
SHEET 11	TYPICAL END WALL AND SIDE WALL FRAMING SECTIONS (BOW RAFTER)
SHEET 12	CONNECTION DETAILS
SHEET 13	CONNECTION DETAILS
SHEET 14	LEAN-TO OPTIONS (BOX EAVE RAFTER)
SHEET 14A	LEAN-TO OPTIONS (BOX EAVE RAFTER)
SHEET 15	LEAN-TO OPTIONS (BOW EAVE RAFTER)
SHEET 15A	LEAN-TO OPTIONS (BOW EAVE RAFTER)
SHEET 16	BOX EAVE RAFTER VERTICAL ROOF OPTION END AND SIDE ELEVATION AND SECTION
SHEET 17	SIDE WALL HEADER OPTIONS
SHEET 18	END WALL HEADER OPTIONS

MOORE AND ASSOCIATES ENGINEERING AND CONSULTING, INC.	DRAWN BY: LT	TOL BUILDINGS, INC. P.O. BOX 542 TOAST, NC 27049 30'-0"x20'-0" ENCLOSED STRUCTURE		
	CHECKED BY: PDH	PROJECT MGR: WSH	DATE: 3-21-22	SCALE: NTS
THIS DOCUMENT IS THE PROPERTY OF MOORE AND ASSOCIATES ENGINEERING AND CONSULTING. THE UNAUTHORIZED REPRODUCTION, COPYING, OR OTHERWISE USE OF THIS DOCUMENT IS STRICTLY PROHIBITED AND ANY INFRINGEMENT THEREUPON MAY BE SUBJECT TO LEGAL ACTION.	CLIENT: TOL	SHT. 2A	DWG. NO SK-3	JOB NO: 19164S/22020S REV: 1

INSTALLATION NOTES AND SPECIFICATIONS

1. DESIGN IS FOR MAXIMUM 30'-0" WIDE x 20'-0" EAVE HEIGHT ENCLOSED STRUCTURES.
2. DESIGN WAS DONE IN ACCORDANCE WITH ALL APPLICABLE BUILDING CODES LISTED ON SHEET 3A.
3. DESIGN LOADS ARE AS FOLLOWS:
 - A) ROOF DEAD LOADS:
 - SELF-WEIGHT = 1.5 PSF
 - MEP = 0 PSF FOR RISK CAT. I (10 PSF FOR RISK CAT. II)
 - COLLATERAL = 0 PSF
 - B) ROOF LIVE LOAD = 12 PSF FOR RISK CAT. I (20 PSF FOR RISK CAT. II)
 - C) FLOOR LIVE LOAD = 100 PSF (4" CONCRETE SLAB-ON-GRADE)
 - D) GROUND SNOW LOAD = 30 PSF ($\leq 24'-0"$) FOR U-CHANNEL PEAK BRACE
 - = 60 PSF ($\leq 30'-0"$), WITH WELDED RAFTER TIE TO SINGLE 12 GA. TS. @ 3'-0" O.C.
 - = 70 PSF ($24'-0" < W \leq 30'-0"$)

NOTE: UNBALANCED LOADING DUE TO SNOW DRIFTING FROM AN ADJACENT TALLER STRUCTURE HAS NOT BEEN EVALUATED.
4. ULTIMATE WIND SPEED (LW) 105 (RC I) (115 MPH (RC II) TO 145 (RC I) (155 MPH (RC II)) (NOMINAL WIND SPEED 81 (89) TO 112 (120) MPH); MAXIMUM RAFTER/POST AND END POST SPACING = 4.0 FEET (5.0 FEET FOR WIND SPEED 105 MPH $< T \leq 145$ MPH RC I ONLY).
5. END WALL COLUMN/POSTS ARE EQUIVALENT TO SIDE WALL COLUMN/POSTS IN SIZE AND SPACING UNLESS NOTED OTHERWISE.
6. RISK CATEGORY I AND II (RISK CATEGORY I NOT FOR HUMAN HABITATION).
7. WIND EXPOSURE CATEGORY B OR C.
8. SPECIFICATIONS APPLICABLE TO 29 GAUGE (FOR SL ≤ 60 PSF) AND 26 GAUGE (FOR SL > 60 PSF) METAL PANELS FASTENED DIRECTLY TO 2 1/2"x2 1/2"-14 GAUGE TUBE STEEL (TS) FOR (RC I) AND 2 1/4"x2 1/4"-12 GAUGE (TS) FOR (RC II). FRAMING MEMBERS (UNLESS NOTED OTHERWISE).
9. CONNECTOR SLEEVES ARE MINIMUM 6' LONG, TS 2 1/4"x2 1/4"-14 GAUGE FOR 2 1/2"x2 1/2"-14 GAUGE AND TS 2"x2"-12 GAUGE FOR 2 1/4"x2 1/4"-12 GAUGE FRAMING MEMBERS (UNLESS NOTED OTHERWISE).
10. STRUCTURAL ANALYSIS/DESIGN IS BASED ON TS MEETING THE REQUIREMENTS OF ASTM A653 GRADE 50 WITH MINIMUM YIELD STRENGTH (F_y) OF 54 KSI AND GALVANIZING MEETING THE MINIMUM REQUIREMENTS OF G60.
11. AVERAGE PANEL FASTENER SPACING ON-CENTERS = 8" O.C. (MAX.).
12. FASTENERS CONSIST OF #12-14x3/4" SELF-DRILLING FASTENER (SDF), USE CONTROL SEAL WASHER WITH EXTERIOR FASTENERS. SPECIFICATIONS APPLICABLE ONLY FOR MEAN ROOF HEIGHT OF 20 FEET OR LESS. ROOF SLOPES VARY FROM 4:12, 3:12, 2:12 TO 1:12.
13. ANCHORS SHALL BE INSTALLED THROUGH BASE RAIL AT OR WITHIN 6" OF EVERY COLUMN.
14. STANDARD GROUND ANCHORS (SOIL NAILS) CONSIST OF #4 REBAR W/ WELDED NUT x 36" LONG AND MAY ONLY BE USED FOR RC I STRUCTURES IN SUITABLE SOILS FOR WIND SPEEDS ≤ 145 MPH. OPTIONAL ANCHORAGE MAY BE USED IN SUITABLE SOILS AND MUST BE USED FOR WIND SPEEDS > 145 MPH. OPTIONAL ANCHORAGE MAY BE USED IN SUITABLE SOILS AND MUST BE USED IN UNSUITABLE SOILS AS NOTED. COORDINATE WITH LOCAL CODES/ORDINANCES REGARDING MINIMUM LENGTH FOR FROST DEPTH PROTECTION.
15. CONTRACTOR TO PROVIDE ADEQUATE BRACING FOR STRUCTURE SO THAT IT WILL BE STABLE DURING ALL STAGES OF CONSTRUCTION. THE STRUCTURE AND FOUNDATION ARE DESIGNED FOR A COMPLETED CONDITION ONLY AND, THEREFORE, REQUIRE ADDITIONAL SUPPORT TO MAINTAIN STABILITY BEFORE COMPLETION.
16. WIND FORCES GOVERN OVER SEISMIC FORCES. SEISMIC PARAMETERS ANALYZED ARE:
 - SOIL SITE CLASS = D
 - RISK CATEGORY I/II
 - $R = 3.25$ $I_E = 1.0$
 - $S_{DS} = 2.625 g$ $V = C_s W$
 - $S_{D1} = 2.13 g$
17. FOR RISK CATEGORY II, MAXIMUM THRESHOLD HEIGHT FOR PERSONNEL DOOR(S) USED FOR DEFINED MEANS OF EGRESS IS 1/2'.
18. APPLY LAP SEALANT TO METAL ROOF PANELS FOR ROOF SLOPES LESS THAN 3:12.
19. IF MORE THAN 50% OF COLUMN (LEG) ARE REMOVED IN ANY LONGITUDINAL (SIDE) WALLS OF A BUILDING, THE ENGINEER IS TO BE NOTIFIED TO DETERMINE WHETHER PORTAL FRAMES OR OTHER LONGITUDINAL STABILITY ELEMENTS WILL BE REQUIRED.
20. **THIS MASTER DESIGN IS A GENERIC MASTER DESIGN PRIMARILY INTENDED FOR PLANT FABRICATION AND ERECTION AHEAD TO SHOP DRAWINGS. THE MASTER DESIGN IS NOT PRIMARILY INTENDED FOR CONSTRUCTION PERMIT. WHEN APPLYING FOR BUILDING PERMIT, THE CERTIFIED BUILDING OFFICIAL MUST BE CONSULTED TO VERIFY WHETHER THE USE OF THE MASTER DESIGN IS ADEQUATE OR IF A SITE-SPECIFIC DESIGN IS REQUIRED FOR BUILDING PERMIT. ANY VARIATION FROM THE ANALYSIS/DESIGN PARAMETERS OF THE MASTER DESIGN REQUIRES THE DEVELOPMENT OF A SITE-SPECIFIC DESIGN.**

**MOORE AND ASSOCIATES
ENGINEERING AND CONSULTING, INC.**

DRAWN BY: LT

CHECKED BY: PDH

PROJECT MGR: WSH

CLIENT: TOL

TOL BUILDINGS, INC.

P.O. BOX 542

TOAST, NC 27049

30'-0"x20'-0" ENCLOSED STRUCTURE

DATE: 3-21-22

SHT. 3

SCALE: NTS

DWG. NO: SK-3

JOB NO:

19164S/B2020S

REV: 1

THIS DOCUMENT IS THE PROPERTY OF MOORE AND ASSOCIATES ENGINEERING AND CONSULTING. THE UNAUTHORIZED REPRODUCTION, COPYING, OR OTHERWISE USE OF THIS DOCUMENT IS STRICTLY PROHIBITED AND ANY INFRINGEMENT THEREUPON MAY BE SUBJECT TO LEGAL ACTION.

LIST OF APPLICABLE BUILDING CODES

2021 INTERNATIONAL BUILDING CODE (IBC 2021)

2018 INTERNATIONAL BUILDING CODE (IBC 2018)

2015 INTERNATIONAL BUILDING CODE (IBC 2015)

2012 INTERNATIONAL BUILDING CODE (IBC 2012)

BUILDING CODE 2015 OF ALABAMA
 (ADOPTS THE IBC 2015 WITHOUT AMENDMENTS)
 (IBC 2015, IBC 2018 (DEPENDENT UPON LOCAL JURISDICTION))

GEORGIA STATE MINIMUM STANDARD BUILDING CODE
 (ADOPTS THE IBC 2018 WITH AMENDMENTS)

MA STATE BUILDING CODE, 9TH ED, BASE VOLUME
 (ADOPTS THE IBC 2015 WITH AMENDMENTS)

2020 BUILDING CODE OF NEW YORK STATE
 (ADOPTS THE IBC 2018 WITH AMENDMENTS)
 NYC BUILDING CODE 2014
 (ADOPTS THE IBC 2009 WITH AMENDMENTS)

2018 NORTH CAROLINA BUILDING CODE
 (ADOPTS THE IBC 2015 WITH AMENDMENTS)

OHIO BUILDING CODE 2017
 (ADOPTS THE 2015 WITH AMENDMENTS)

BUILDING CODE 2018 OF PENNSYLVANIA
 (ADOPTS THE IBC 2018 WITH AMENDMENTS)
 PHILADELPHIA BUILDING CODE
 (ADOPTS THE IBC 2018 WITH AMENDMENTS)

2018 SOUTH CAROLINA BUILDING CODE
 (ADOPTS THE IBC 2018 WITH AMENDMENTS)

BUILDING CODE 2012 OF TENNESSEE
 (ADOPTS THE IBC 2012 WITH AMENDMENTS)
 BUILDING CODE 2018 OF NASHVILLE AND DAVIDSON
 COUNTY (ADOPTS THE IBC 2018 WITH AMENDMENTS)

2018 VIRGINIA CONSTRUCTION CODE
 (ADOPTS THE IBC 2018 WITH AMENDMENTS)

BUILDINGS

**MOORE AND ASSOCIATES
 ENGINEERING AND CONSULTING, INC.**

DRAWN BY: LT

CHECKED BY: PDH

PROJECT MGR: VSM

CLIENT: TOL

TOL BUILDINGS, INC.
 P.O. BOX 542
 TOAST, NC 27049
 30'-0"x20'-0" ENCLOSED STRUCTURE

DATE: 3-21-22

SHT. 3A

SCALE: NTS

DWG. NO SK-3

**JOB NO:
 191643/22020S**

REV: 1

THIS DOCUMENT IS THE PROPERTY OF MOORE AND ASSOCIATES ENGINEERING AND CONSULTING. THE UNAUTHORIZED REPRODUCTION, COPYING, OR OTHERWISE USE OF THIS DOCUMENT IS STRICTLY PROHIBITED AND ANY INFRINGEMENT THEREUPON MAY BE SUBJECT TO LEGAL ACTION.

BOX EAVE FRAME RAFTER STRUCTURE

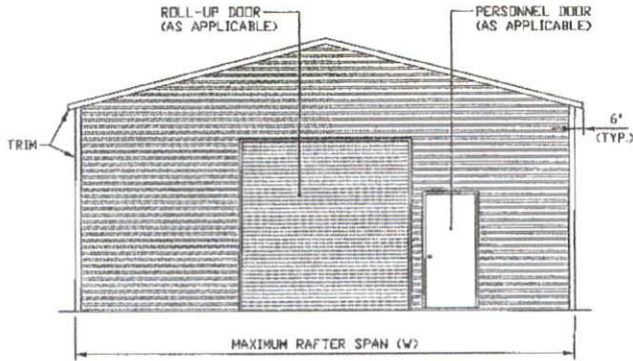

TYPICAL END ELEVATION
SCALE: NTS

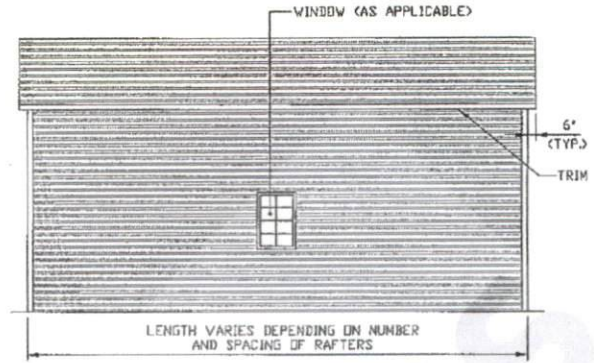

TYPICAL SIDE ELEVATION
SCALE: NTS

BOX EAVE FRAME RAFTER STRUCTURE

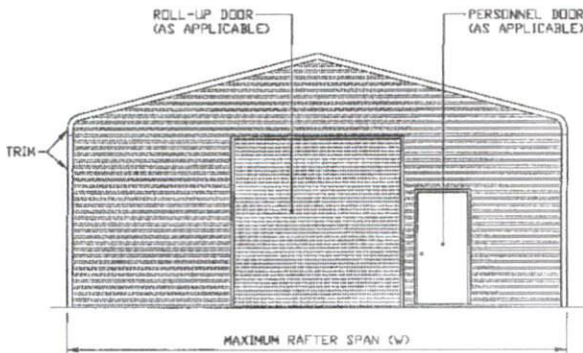

TYPICAL END ELEVATION
SCALE: NTS

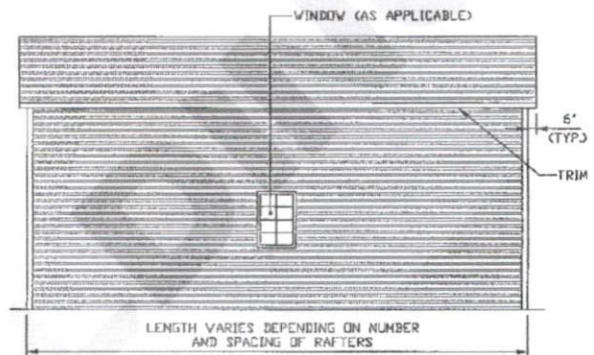

TYPICAL SIDE ELEVATION
SCALE: NTS

**MOORE AND ASSOCIATES
ENGINEERING AND CONSULTING, INC.**

DRAWN BY: LT

CHECKED BY: PDH

PROJECT MGR: WSM

CLIENT: TOL

TOL BUILDINGS, INC.
P.O. BOX 542
TOAST, NC 27049
30'-0" x 20'-0" ENCLOSED STRUCTURE

DATE: 3-21-22

SHT. 4

SCALE: NTS

DWG. NO: SK-3

**JOB NO:
19164S/22020S**

REV: 1

THIS DOCUMENT IS THE PROPERTY OF MOORE AND ASSOCIATES ENGINEERING AND CONSULTING. THE UNAUTHORIZED REPRODUCTION, COPYING, OR OTHERWISE USE OF THIS DOCUMENT IS STRICTLY PROHIBITED AND ANY INFRINGEMENT THEREUPON MAY BE SUBJECT TO LEGAL ACTION.

60 PSF < SL ≤ 70 PSF

EXPOSURE B

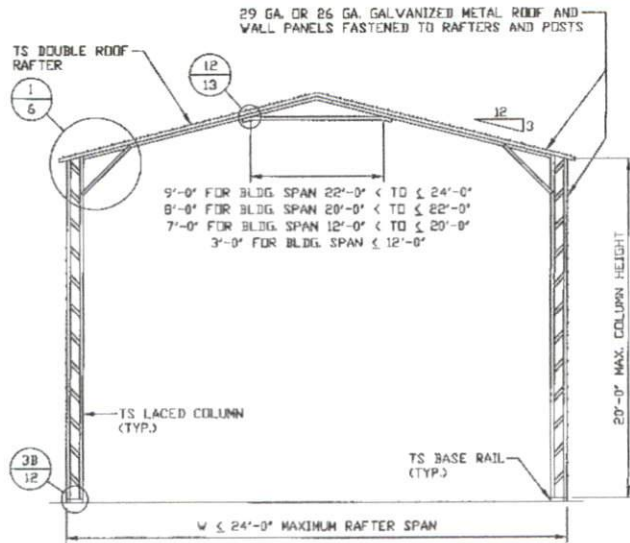

TYPICAL RAFTER/COLUMN END FRAME SECTION
SCALE: NTS

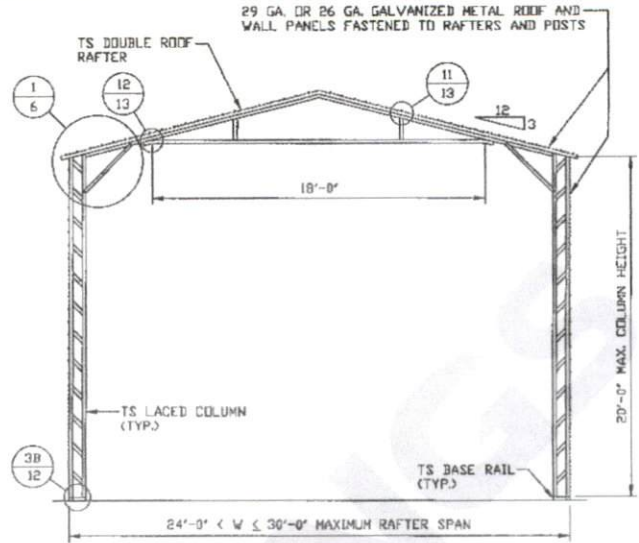

TYPICAL RAFTER/COLUMN END FRAME SECTION
SCALE: NTS

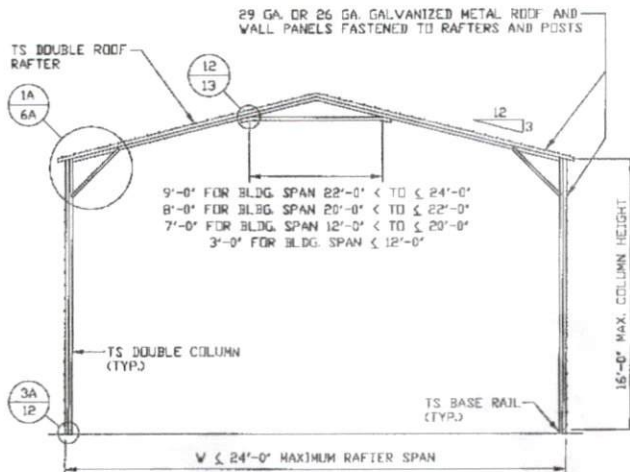

TYPICAL RAFTER/COLUMN END FRAME SECTION
SCALE: NTS

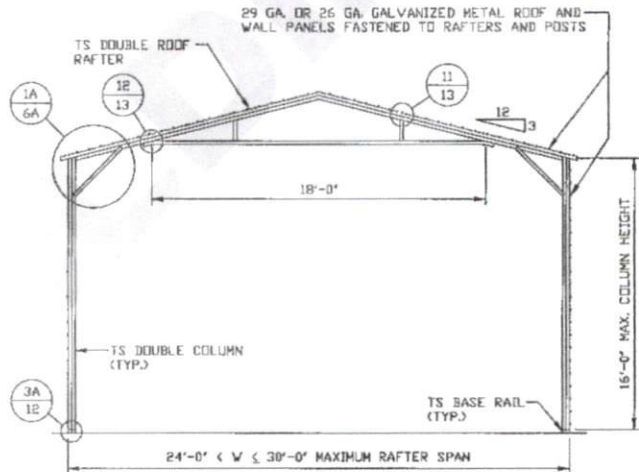

TYPICAL RAFTER/COLUMN END FRAME SECTION
SCALE: NTS

MOORE AND ASSOCIATES
ENGINEERING AND CONSULTING, INC.

DRAWN BY: LT

CHECKED BY: PDH

PROJECT MGR: WSM

CLIENT: TOL

TOL BUILDINGS, INC.
P.O. BOX 542
TOAST, NC 27049
30'-0" x 20'-0" ENCLOSED STRUCTURE

DATE: 3-21-22

SCALE: NTS

DWG. NO: SK-3

JOB NO:
19164S/22020S

SHT. 5

REV: 1

THIS DOCUMENT IS THE PROPERTY OF MOORE AND ASSOCIATES ENGINEERING AND CONSULTING. THE UNAUTHORIZED REPRODUCTION, COPYING, OR OTHERWISE USE OF THIS DOCUMENT IS STRICTLY PROHIBITED AND ANY INFRINGEMENT THEREUPON MAY BE SUBJECT TO LEGAL ACTION.

60 PSF < SL ≤ 70 PSF

EXPOSURE B

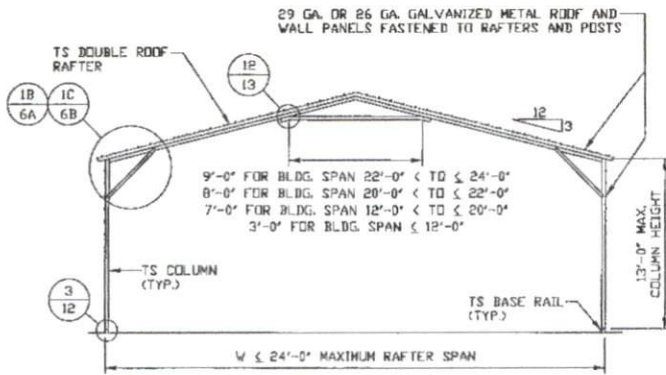

TYPICAL RAFTER/COLUMN END FRAME SECTION

SCALE: NTS

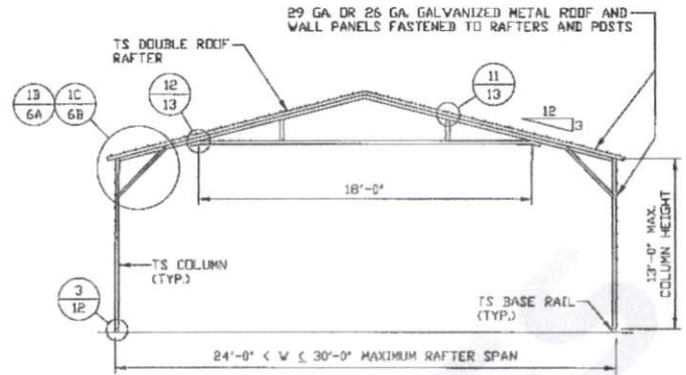

TYPICAL RAFTER/COLUMN END FRAME SECTION

SCALE: NTS

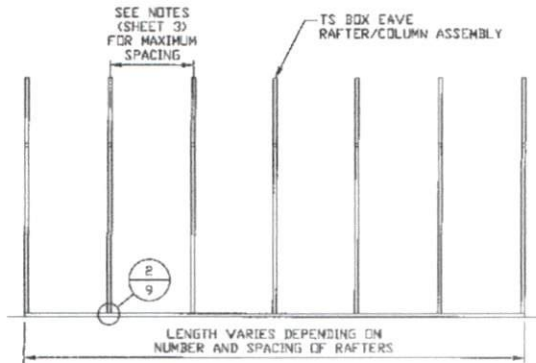

TYPICAL RAFTER/COLUMN SIDE FRAMING SECTION

SCALE: NTS

MOORE AND ASSOCIATES
ENGINEERING AND CONSULTING, INC.

DRAWN BY: LT

CHECKED BY: PDH

PROJECT MGR: WSH

CLIENT: TOL

TOL BUILDINGS, INC.
P.O. BOX 542
TOAST, NC 27049
30'-0" x 20'-0" ENCLOSED STRUCTURE

DATE: 3-21-22

SCALE: NTS

JOB NO:
19164S/22020S

SHT. 5A

DWG. NO SK-3

REV: 1

THIS DOCUMENT IS THE PROPERTY OF MOORE AND ASSOCIATES ENGINEERING AND CONSULTING. THE UNAUTHORIZED REPRODUCTION, COPYING, OR OTHERWISE USE OF THIS DOCUMENT IS STRICTLY PROHIBITED AND ANY INFRINGEMENT THEREUPON MAY BE SUBJECT TO LEGAL ACTION.

60 PSF < SL ≤ 70 PSF

EXPOSURE C

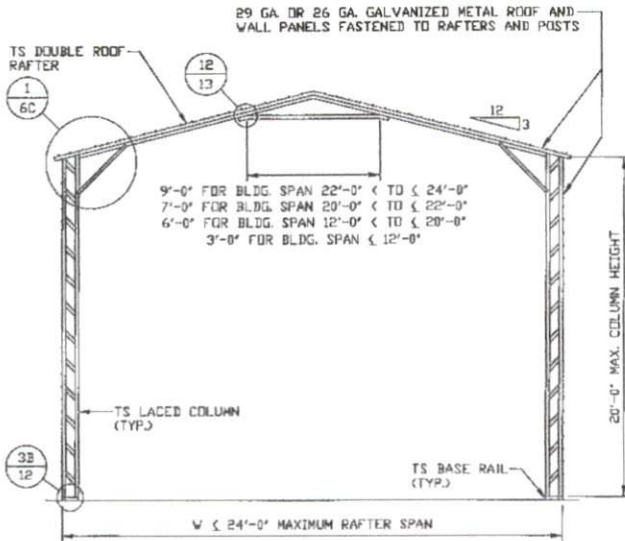

TYPICAL RAFTER/COLUMN END FRAME SECTION

SCALE: NTS

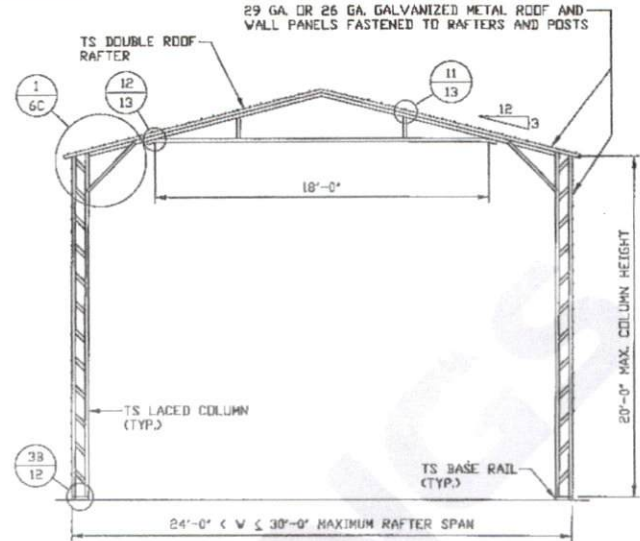

TYPICAL RAFTER/COLUMN END FRAME SECTION

SCALE: NTS

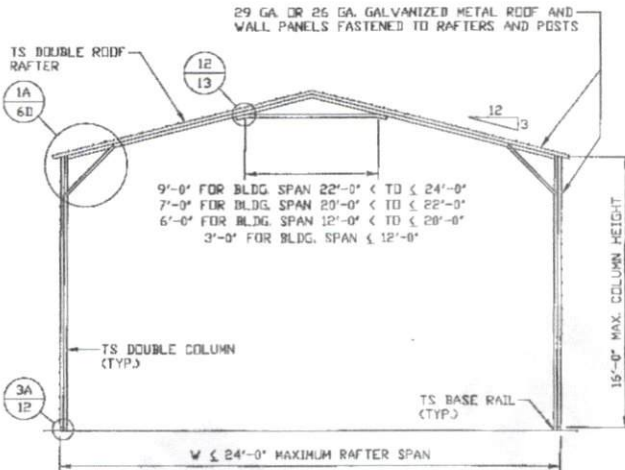

TYPICAL RAFTER/COLUMN END FRAME SECTION

SCALE: NTS

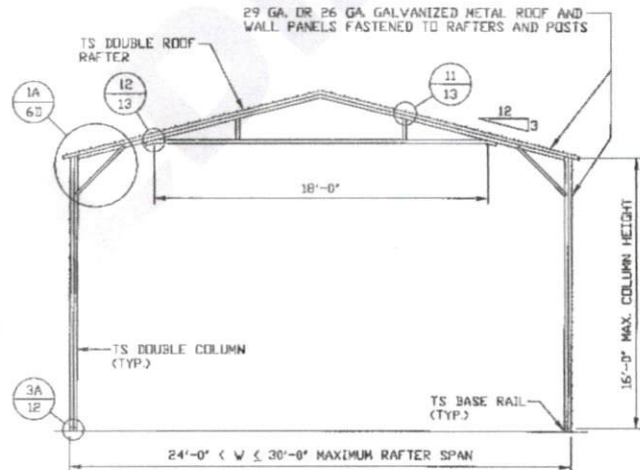

TYPICAL RAFTER/COLUMN END FRAME SECTION

SCALE: NTS

MOORE AND ASSOCIATES
ENGINEERING AND CONSULTING, INC.

DRAWN BY: LT

CHECKED BY: PDH

PROJECT MGR: WSM

CLIENT: TOL

TOL BUILDINGS, INC.
P.O. BOX 542
TOAST, NC 27049
30'-0" x 20'-0" ENCLOSED STRUCTURE

DATE: 3-21-22

SHT. 5B

SCALE: NTS

DWG. NO: SK-3

JOB NO:
19164S/22020S

REV: 1

THIS DOCUMENT IS THE PROPERTY OF MOORE AND ASSOCIATES ENGINEERING AND CONSULTING. THE UNAUTHORIZED REPRODUCTION, COPYING, OR OTHERWISE USE OF THIS DOCUMENT IS STRICTLY PROHIBITED AND ANY INFRINGEMENT THEREUPON MAY BE SUBJECT TO LEGAL ACTION.

60 PSF < SL ≤ 70 PSF

EXPOSURE C

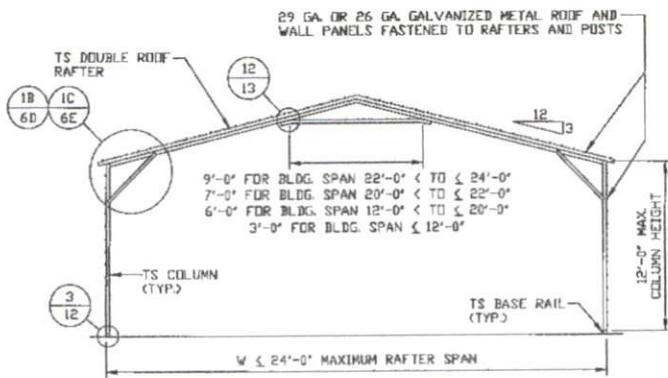

TYPICAL RAFTER/COLUMN END FRAME SECTION
SCALE: NTS

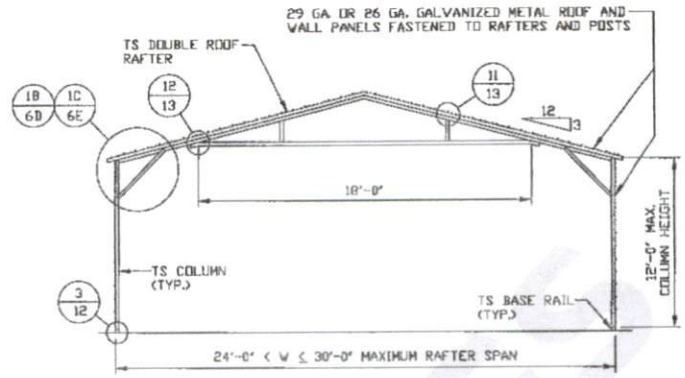

TYPICAL RAFTER/COLUMN END FRAME SECTION
SCALE: NTS

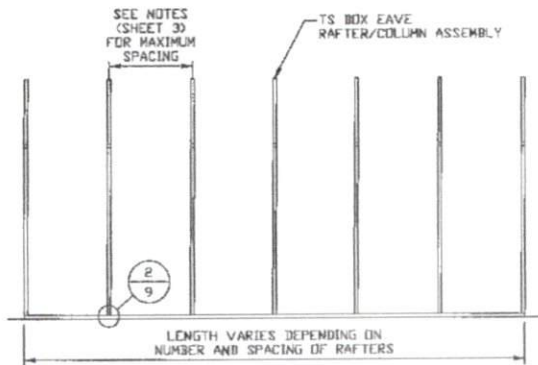

TYPICAL RAFTER/COLUMN SIDE FRAMING SECTION
SCALE: NTS

**MOORE AND ASSOCIATES
ENGINEERING AND CONSULTING, INC.**

DRAWN BY: LT

CHECKED BY: PDH

PROJECT MGR: WSH

CLIENT: TOL

TOL BUILDINGS, INC.
P.O. BOX 542
TOAST, NC 27049
30'-0" x 20'-0" ENCLOSED STRUCTURE

DATE: 3-21-22

SHT. 5C

SCALE: NTS

DWG. NO: SK-3

**JOB NO:
19164S/22020S**

REV: 1

THIS DOCUMENT IS THE PROPERTY OF MOORE AND ASSOCIATES ENGINEERING AND CONSULTING. THE UNAUTHORIZED REPRODUCTION, COPYING, OR OTHERWISE USE OF THIS DOCUMENT IS STRICTLY PROHIBITED AND ANY INFRINGEMENT THEREUPON MAY BE SUBJECT TO LEGAL ACTION.

SL ≤ 60 PSF
EXPOSURE B/C

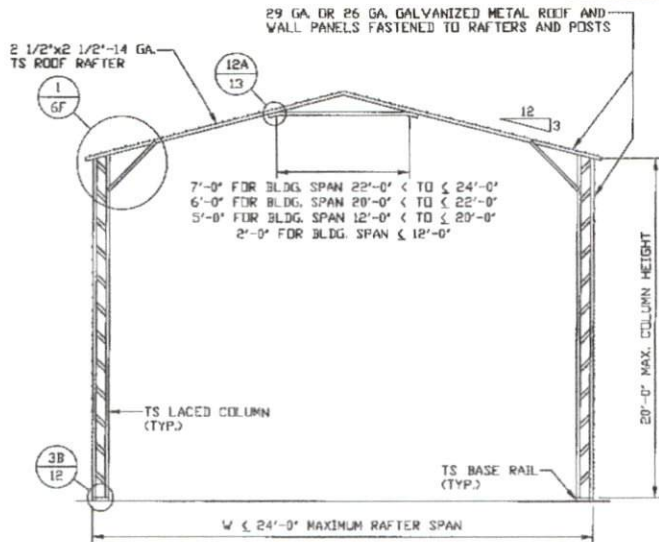

TYPICAL RAFTER/COLUMN END FRAME SECTION
SCALE: NTS

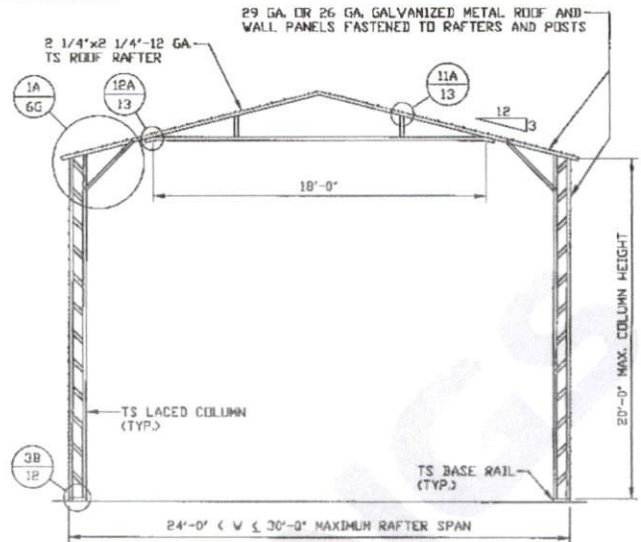

TYPICAL RAFTER/COLUMN END FRAME SECTION
SCALE: NTS

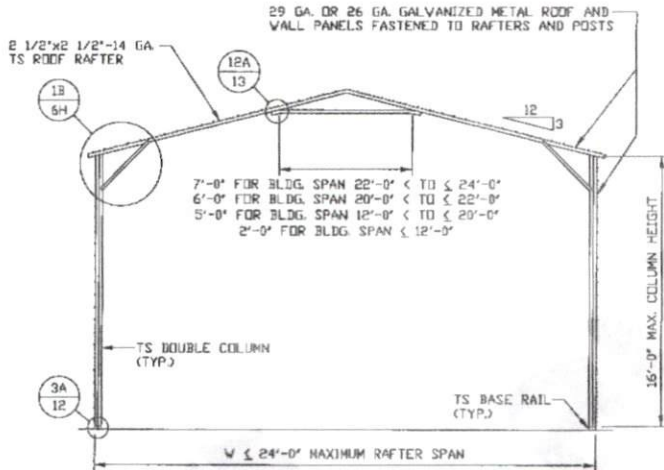

TYPICAL RAFTER/COLUMN END FRAME SECTION
SCALE: NTS

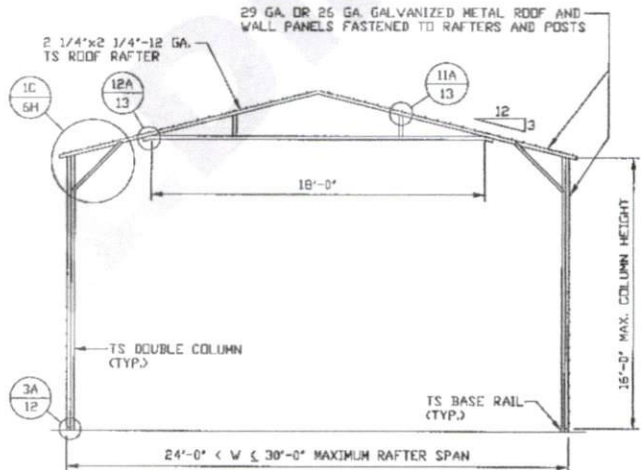

TYPICAL RAFTER/COLUMN END FRAME SECTION
SCALE: NTS

MOORE AND ASSOCIATES
ENGINEERING AND CONSULTING, INC.

DRAWN BY: LT

CHECKED BY: PDH

PROJECT MGR: WSH

CLIENT: TOL

TOL BUILDINGS, INC.

P.O. BOX 542

TOAST, NC 27049

30'-0"x20'-0" ENCLOSED STRUCTURE

DATE: 3-21-22

SHT. 5D

SCALE: NTS

DWG. NO: SK-3

JOB NO.
19164S/22026S

REV: 1

THIS DOCUMENT IS THE PROPERTY OF MOORE AND ASSOCIATES ENGINEERING AND CONSULTING. THE UNAUTHORIZED REPRODUCTION, COPYING, OR OTHERWISE USE OF THIS DOCUMENT IS STRICTLY PROHIBITED AND ANY INFRINGEMENT THEREUPON MAY BE SUBJECT TO LEGAL ACTION.

SL ≤ 60 PSF
EXPOSURE B/C

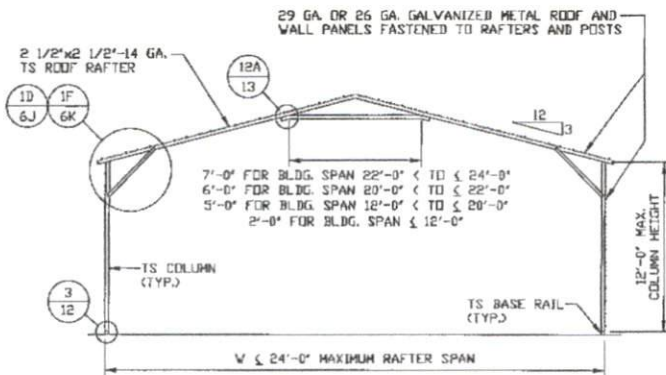

TYPICAL RAFTER/COLUMN END FRAME SECTION
SCALE: NTS

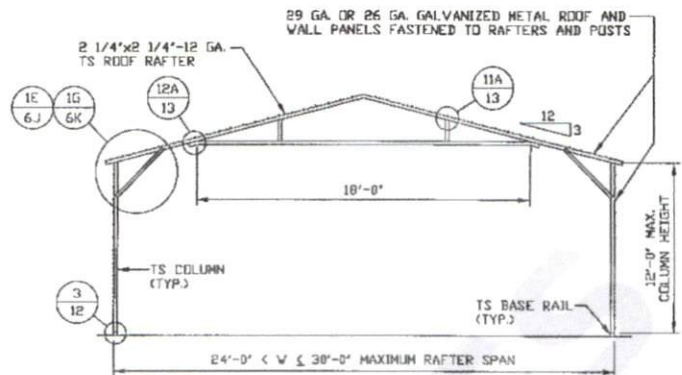

TYPICAL RAFTER/COLUMN END FRAME SECTION
SCALE: NTS

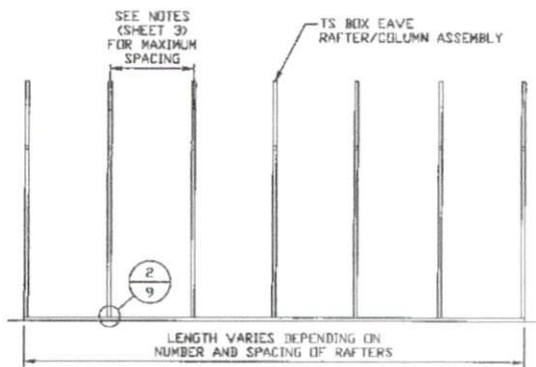

TYPICAL RAFTER/COLUMN SIDE FRAMING SECTION
SCALE: NTS

**MOORE AND ASSOCIATES
ENGINEERING AND CONSULTING, INC.**

DRAWN BY: LT

CHECKED BY: PDH

PROJECT MGR: WSM

CLIENT: TOL

TOL BUILDINGS, INC.
P.O. BOX 542
TOAST, NC 27049
30'-0" x 20'-0" ENCLOSED STRUCTURE

DATE: 3-21-22

SHT. 5E

SCALE: NTS

DWG. NO: SK-3

JOB NO:
19164S/22020S

REV: 1

THIS DOCUMENT IS THE PROPERTY OF MOORE AND ASSOCIATES ENGINEERING AND CONSULTING. THE UNAUTHORIZED REPRODUCTION, COPYING, OR OTHERWISE USE OF THIS DOCUMENT IS STRICTLY PROHIBITED AND ANY INFRINGEMENT THEREUPON MAY BE SUBJECT TO LEGAL ACTION.

SL ≤ 30 PSF
EXPOSURE B/C

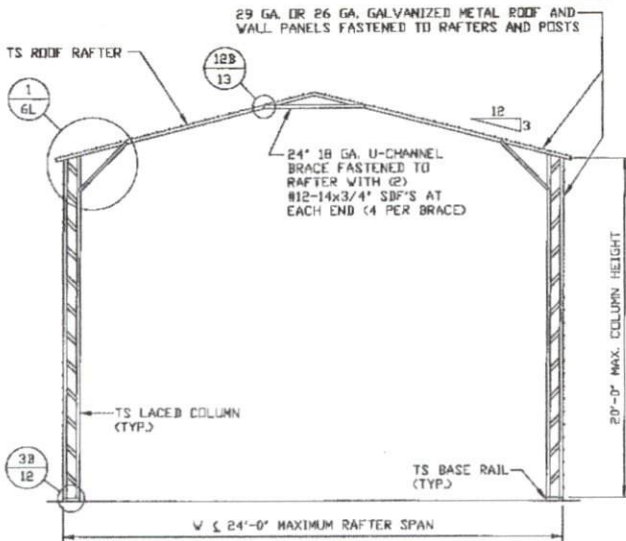

TYPICAL RAFTER/COLUMN END FRAME SECTION
SCALE: NTS

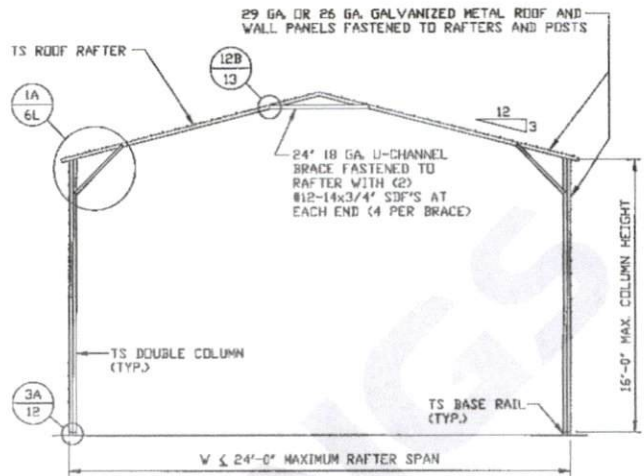

TYPICAL RAFTER/COLUMN END FRAME SECTION
SCALE: NTS

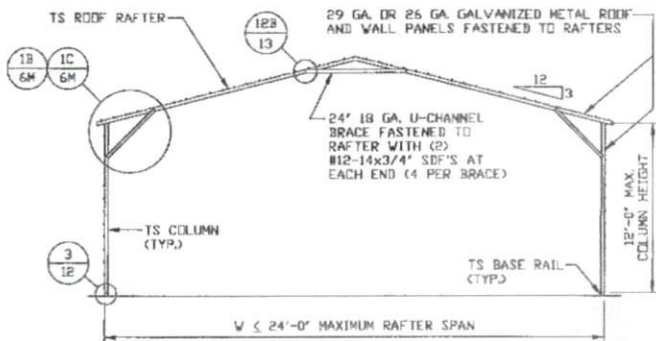

TYPICAL RAFTER/COLUMN END FRAME SECTION
SCALE: NTS

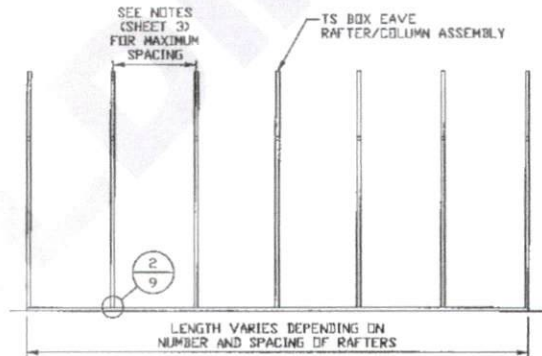

TYPICAL RAFTER/COLUMN SIDE FRAMING SECTION
SCALE: NTS

MOORE AND ASSOCIATES
ENGINEERING AND CONSULTING, INC.

DRAWN BY: LT

CHECKED BY: PDH

PROJECT MGR: VSM

CLIENT: TOL

TOL BUILDINGS, INC.

P.O. BOX 542

TOAST, NC 27049

30'-0" x 20'-0" ENCLOSED STRUCTURE

DATE: 3-21-22

SHT. 5F

SCALE: NTS

DWG. NO: SK-3

JOB NO: 19164S/22020S

REV: 1

THIS DOCUMENT IS THE PROPERTY OF MOORE AND ASSOCIATES ENGINEERING AND CONSULTING. THE UNAUTHORIZED REPRODUCTION, COPYING, OR OTHERWISE USE OF THIS DOCUMENT IS STRICTLY PROHIBITED AND ANY INFRENGEMENT THEREUPON MAY BE SUBJECT TO LEGAL ACTION.

60 PSF < SL ≤ 70 PSF
EXPOSURE B

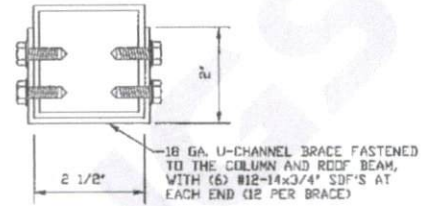
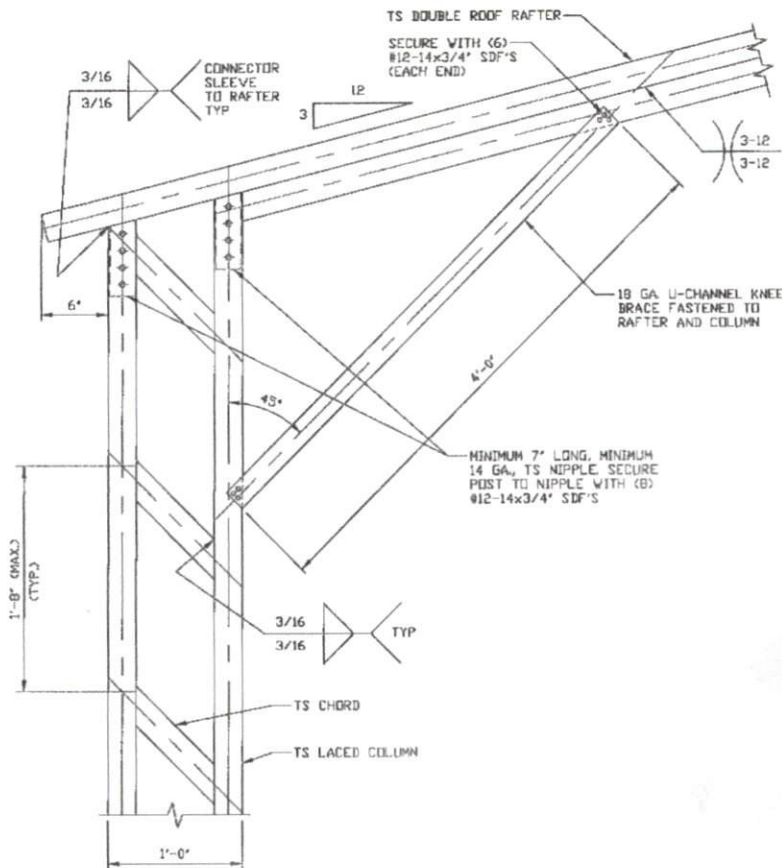

BRACE SECTION
SCALE: NTS

BOX EAVE RAFTER COLUMN CONNECTION DETAIL
FOR HEIGHTS 16'-0" < TO ≤ 20'-0"
HEIGHTS 15'-0" < TO ≤ 20'-0"
FOR APPLICABLE RISK CATEGORY WIND SPEEDS

1
SCALE: NTS

MOORE AND ASSOCIATES
ENGINEERING AND CONSULTING, INC.

DRAWN BY: LT

CHECKED BY: PDH

PROJECT MGR: VSM

CLIENT: TOL

TOL BUILDINGS, INC.
P.O. BOX 542
TOAST, NC 27049
30'-0" x 20'-0" ENCLOSED STRUCTURE

DATE: 3-21-22

SHT. 6

SCALE: NTS

DWG. NO: SK-3

JOB NO:
19164S/22020S

REV: 1

THIS DOCUMENT IS THE PROPERTY OF MOORE AND ASSOCIATES ENGINEERING AND CONSULTING. THE UNAUTHORIZED REPRODUCTION, COPYING, OR OTHERWISE USE OF THIS DOCUMENT IS STRICTLY PROHIBITED AND ANY INFRINGEMENT THEREUPON MAY BE SUBJECT TO LEGAL ACTION.

60 PSF < SL ≤ 70 PSF

EXPOSURE B

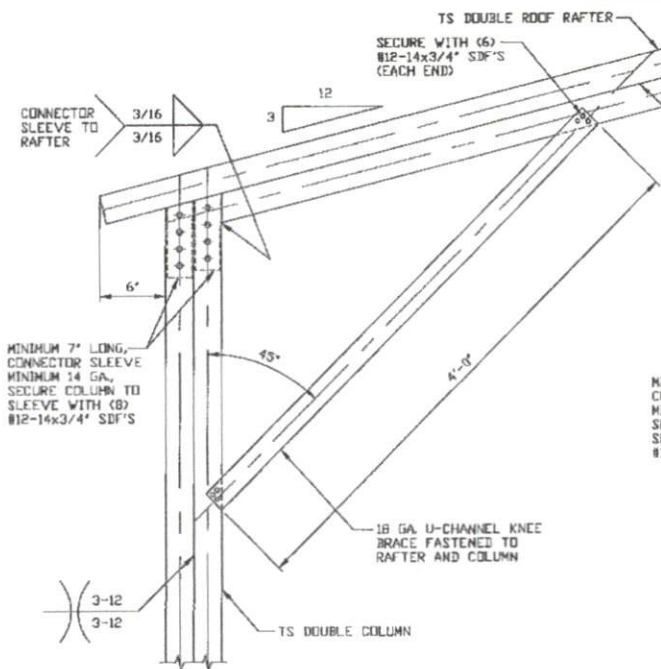

BOX EAVE RAFTER COLUMN CONNECTION DETAIL FOR HEIGHTS 13'-0" < TO ≤ 16'-0" HEIGHTS 11'-0" < TO ≤ 15'-0" FOR APPLICABLE RISK CATEGORY WIND SPEEDS

1A

SCALE: NTS

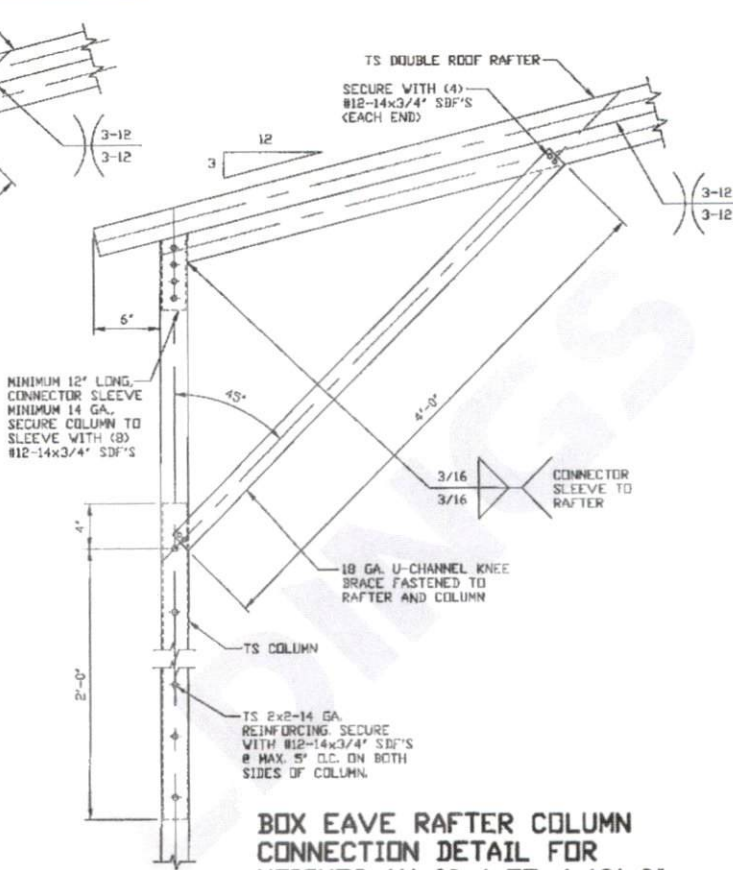

BOX EAVE RAFTER COLUMN CONNECTION DETAIL FOR HEIGHTS 11'-0" < TO ≤ 13'-0" HEIGHTS 9'-0" < TO ≤ 11'-0" FOR APPLICABLE RISK CATEGORY WIND SPEEDS

1B

SCALE: NTS

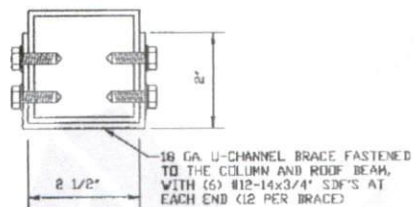

BRACE SECTION

SCALE: NTS

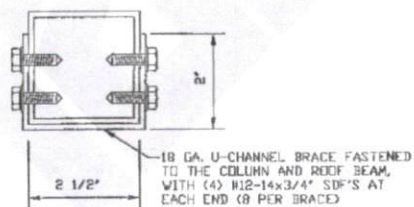

BRACE SECTION

SCALE: NTS

MOORE AND ASSOCIATES ENGINEERING AND CONSULTING, INC.

DRAWN BY: LT
CHECKED BY: PDH

TOL BUILDINGS, INC.
P.O. BOX 542
TOAST, NC 27049
30'-0" x 20'-0" ENCLOSED STRUCTURE

THIS DOCUMENT IS THE PROPERTY OF MOORE AND ASSOCIATES ENGINEERING AND CONSULTING. THE UNAUTHORIZED REPRODUCTION, COPYING, OR OTHERWISE USE OF THIS DOCUMENT IS STRICTLY PROHIBITED AND ANY INFRINGEMENT THEREUPON MAY BE SUBJECT TO LEGAL ACTION.

PROJECT MGR: WSM	DATE: 3-21-22	SCALE: NTS	JOB NO: 19164S/22020S
CLIENT: TOL	SHT. 6A	DWG. NO SK-3	REV: 1

60 PSF < SL ≤ 70 PSF
EXPOSURE B

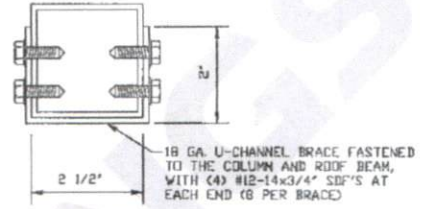
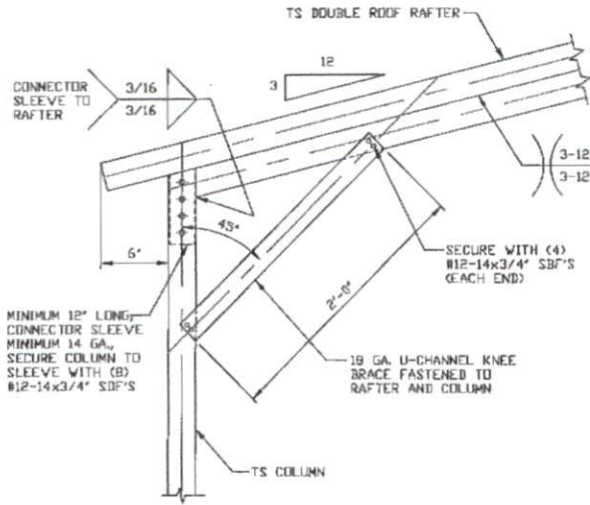

BRACE SECTION
 SCALE: NTS

BOX EAVE RAFTER COLUMN CONNECTION DETAIL FOR HEIGHTS ≤ 11'-0" HEIGHTS ≤ 9'-0" FOR APPLICABLE RISK CATEGORY WIND SPEEDS

1C

SCALE: NTS

MOORE AND ASSOCIATES ENGINEERING AND CONSULTING, INC.

DRAWN BY: LT

CHECKED BY: PDH

PROJECT MGR: WSH

CLIENT: TOL

TOL BUILDINGS, INC.
 P.O. BOX 542
 TOAST, NC 27049
 30'-0"x20'-0" ENCLOSED STRUCTURE

DATE: 3-21-22

SHT. 6B

SCALE: NTS

DWG. NO: SK-3

JOB NO: 19164S/P2020S

REV: 1

THIS DOCUMENT IS THE PROPERTY OF MOORE AND ASSOCIATES ENGINEERING AND CONSULTING. THE UNAUTHORIZED REPRODUCTION, COPYING, OR OTHERWISE USE OF THIS DOCUMENT IS STRICTLY PROHIBITED AND ANY INFRINGEMENT THEREUPON MAY BE SUBJECT TO LEGAL ACTION.

60 PSF < SL ≤ 70 PSF
EXPOSURE C

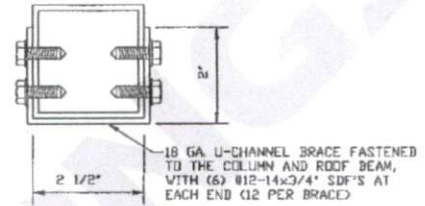
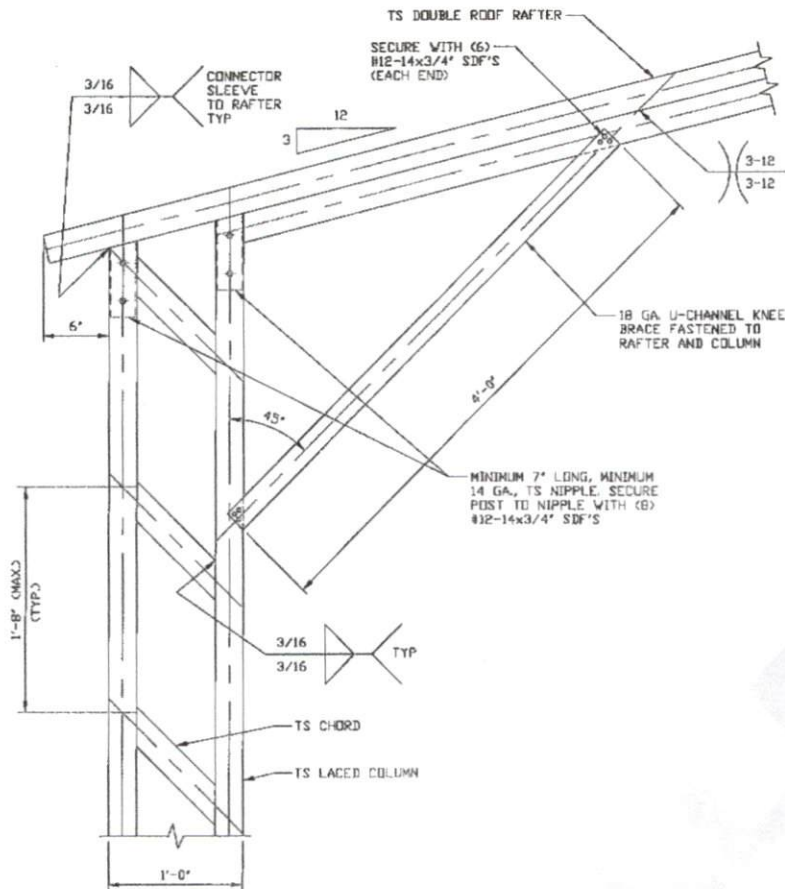

BRACE SECTION
SCALE: NTS

BOX EAVE RAFTER COLUMN CONNECTION DETAIL
FOR HEIGHTS 16'-0" < TO ≤ 20'-0"
HEIGHTS 14'-0" < TO ≤ 20'-0"
FOR APPLICABLE RISK CATEGORY WIND SPEEDS

1
SCALE: NTS

MOORE AND ASSOCIATES
ENGINEERING AND CONSULTING, INC.

DRAWN BY: LT

CHECKED BY: PDH

PROJECT MGR: WSM

CLIENT: TOL

TOL BUILDINGS, INC.
P.O. BOX 542
TOAST, NC 27049
30'-0" x 20'-0" ENCLOSED STRUCTURE

DATE: 3-21-22

SHT. 6C

SCALE: NTS

DWG. NO SK-3

JOB NO:
19164S/22080S

REV: 1

THIS DOCUMENT IS THE PROPERTY OF MOORE AND ASSOCIATES ENGINEERING AND CONSULTING. THE UNAUTHORIZED REPRODUCTION, COPYING, OR OTHERWISE USE OF THIS DOCUMENT IS STRICTLY PROHIBITED AND ANY INFRINGEMENT THEREUPON MAY BE SUBJECT TO LEGAL ACTION.

60 PSF < SL ≤ 70 PSF
EXPOSURE C

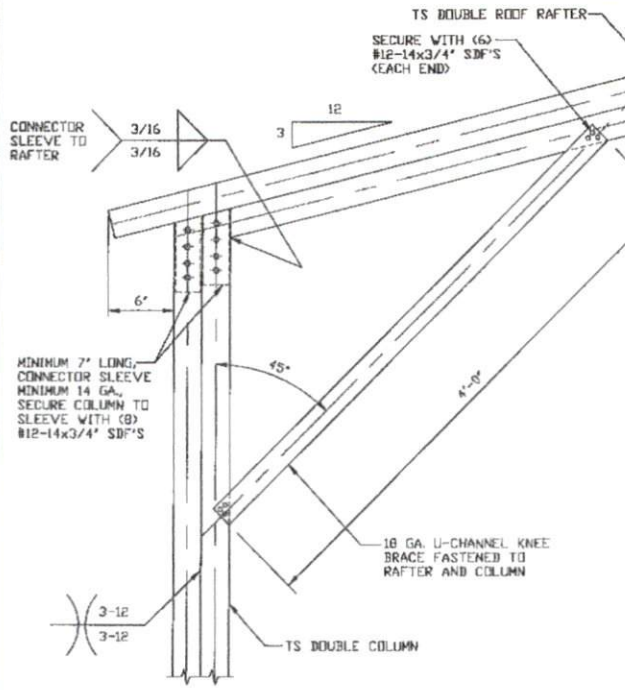

1A

BOX EAVE RAFTER COLUMN CONNECTION DETAIL FOR HEIGHTS 12'-0" < TO ≤ 16'-0" HEIGHTS 10'-0" < TO ≤ 14'-0" FOR APPLICABLE RISK CATEGORY WIND SPEEDS

SCALE: NTS

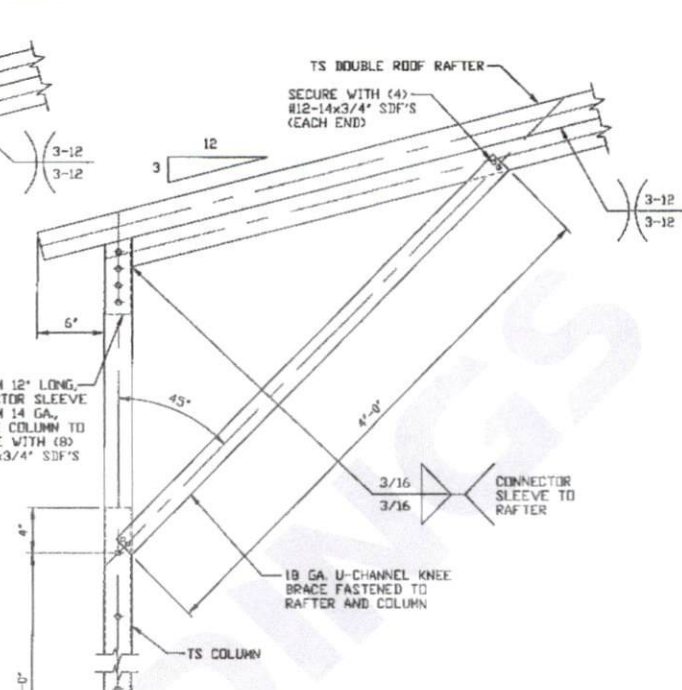

1B

BOX EAVE RAFTER COLUMN CONNECTION DETAIL FOR HEIGHTS 10'-0" < TO ≤ 12'-0" HEIGHTS 9'-0" < TO ≤ 10'-0" FOR APPLICABLE RISK CATEGORY WIND SPEEDS

SCALE: NTS

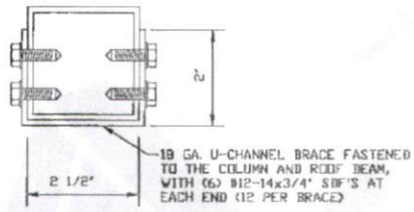

BRACE SECTION

SCALE: NTS

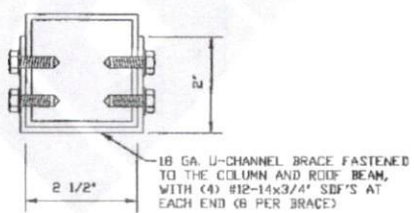

BRACE SECTION

SCALE: NTS

MOORE AND ASSOCIATES ENGINEERING AND CONSULTING, INC.	DRAWN BY: LT	TOL BUILDINGS, INC. P.O. BOX 542 TOAST, NC 27049 30'-0" x 20'-0" ENCLOSED STRUCTURE		
	CHECKED BY: PDH			
PROJECT MGR: WSM	DATE: 3-21-22	SCALE: NTS	JOB NO: 19164S/22020S	
CLIENT: TOL	SHT. 6D	DWG. NO. SK-3	REV. 1	

THIS DOCUMENT IS THE PROPERTY OF MOORE AND ASSOCIATES ENGINEERING AND CONSULTING. THE UNAUTHORIZED REPRODUCTION, COPYING, OR OTHERWISE USE OF THIS DOCUMENT IS STRICTLY PROHIBITED AND ANY INFRINGEMENT THEREUPON MAY BE SUBJECT TO LEGAL ACTION.

60 PSF < SL ≤ 70 PSF

EXPOSURE C

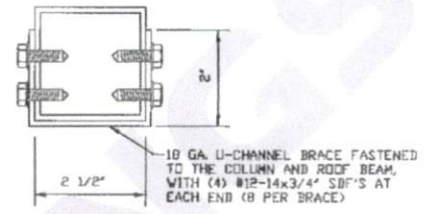
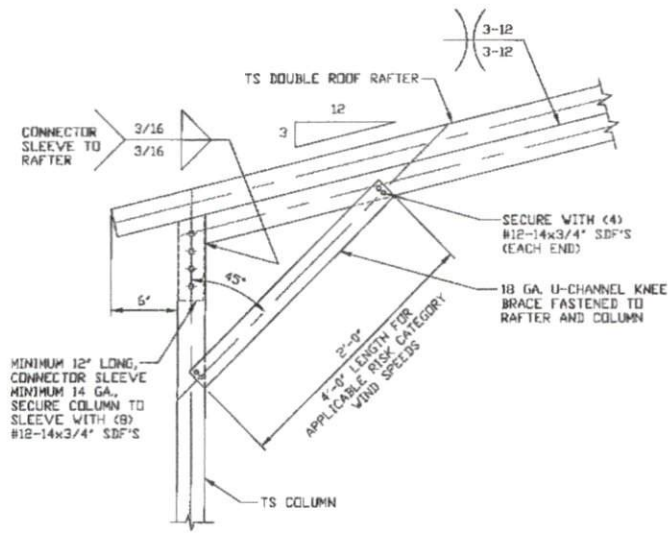

BRACE SECTION
SCALE: NTS

**BOX EAVE RAFTER COLUMN
CONNECTION DETAIL FOR
HEIGHTS ≤ 10'-0"
HEIGHTS ≤ 9'-0"
FOR APPLICABLE RISK
CATEGORY WIND SPEEDS**

1C

SCALE: NTS

**MOORE AND ASSOCIATES
ENGINEERING AND CONSULTING, INC.**

DRAWN BY: LT
CHECKED BY: PDH

TOL BUILDINGS, INC.
P.O. BOX 542
TOAST, NC 27049
30'-0" x 20'-0" ENCLOSED STRUCTURE

THIS DOCUMENT IS THE PROPERTY OF MOORE AND ASSOCIATES ENGINEERING AND CONSULTING. THE UNAUTHORIZED REPRODUCTION, COPYING, OR OTHERWISE USE OF THIS DOCUMENT IS STRICTLY PROHIBITED AND ANY INFRINGEMENT THEREUPON MAY BE SUBJECT TO LEGAL ACTION.

PROJECT MGR: WSM
CLIENT: TOL

DATE: 9-21-22
SHT. 6E

SCALE: NTS
DWG. NO: SK-3
JOB NO: 19164S/PR020S
REV: 1

SL ≤ 60 PSF
EXPOSURE B/C

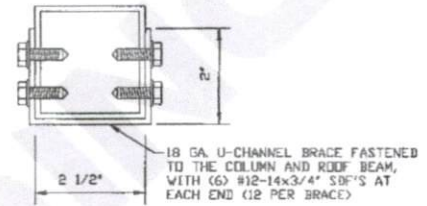
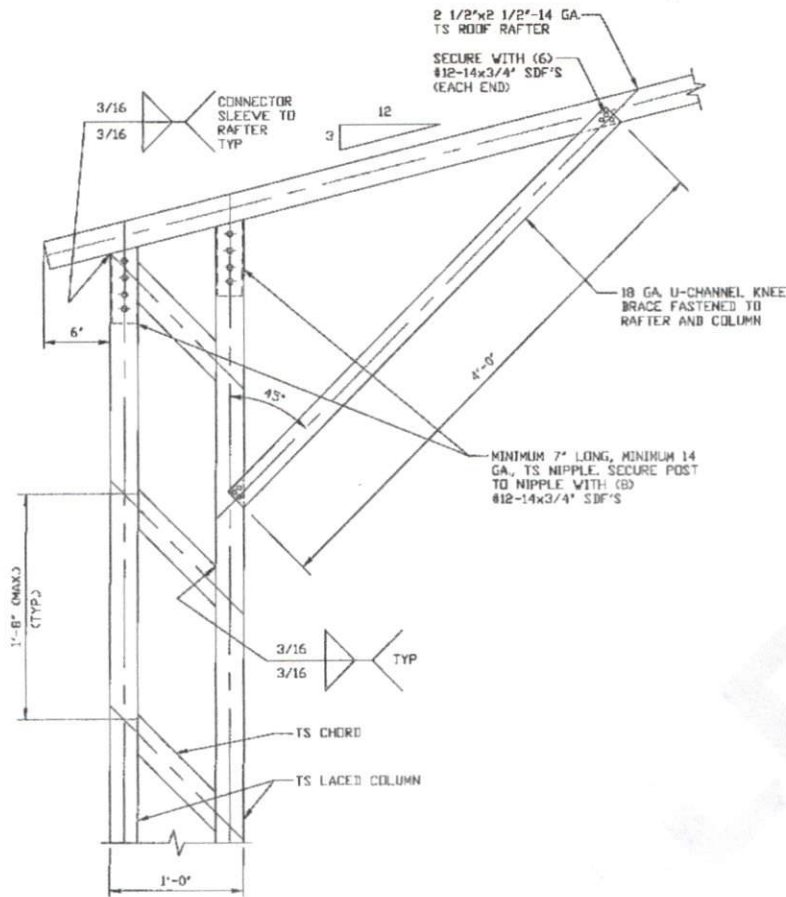

BRACE SECTION
SCALE: NTS

BOX EAVE RAFTER COLUMN CONNECTION DETAIL
FOR HEIGHTS 16'-0" < TO ≤ 20'-0"
HEIGHTS 15'-0" < TO ≤ 20'-0"
FOR APPLICABLE RISK CATEGORY WIND SPEEDS

1
SCALE: NTS

MOORE AND ASSOCIATES ENGINEERING AND CONSULTING, INC.	DRAWN BY: LT	TOL BUILDINGS, INC. P.O. BOX 542 TOAST, NC 27049 30'-0" x 20'-0" ENCLOSED STRUCTURE		
	CHECKED BY: PDH			
<small>THIS DOCUMENT IS THE PROPERTY OF MOORE AND ASSOCIATES ENGINEERING AND CONSULTING. THE UNAUTHORIZED REPRODUCTION, COPYING, OR OTHERWISE USE OF THIS DOCUMENT IS STRICTLY PROHIBITED AND ANY INFRINGEMENT THEREUPON MAY BE SUBJECT TO LEGAL ACTION.</small>	PROJECT MGR: WSM	DATE: 3-21-22	SCALE: NTS	JOB NO: 19164S/22020S
	CLIENT: TOL	SHT. 6F	DWG. NO. SK-3	REV. 1

SL ≤ 60 PSF
EXPOSURE B/C

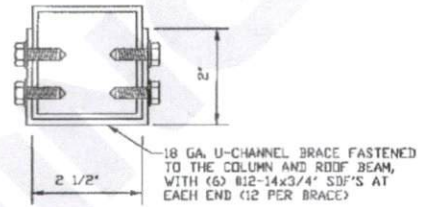
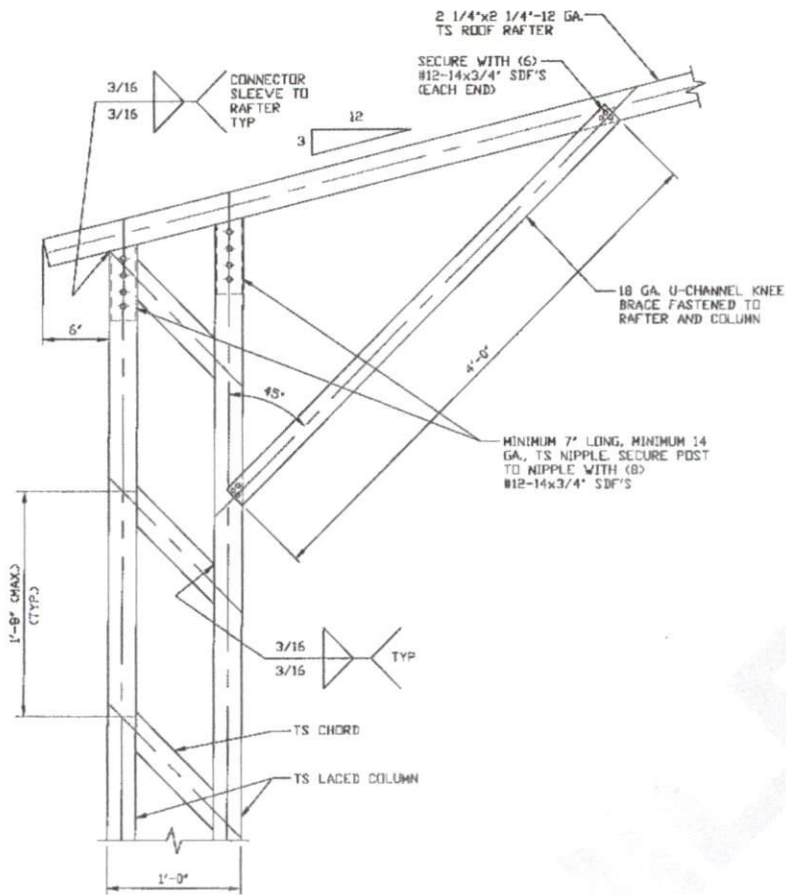

BRACE SECTION
SCALE: NTS

BOX EAVE RAFTER COLUMN CONNECTION DETAIL
FOR HEIGHTS 16'-0" < TO ≤ 20'-0"
HEIGHTS 15'-0" < TO ≤ 20'-0"
FOR APPLICABLE RISK CATEGORY WIND SPEEDS

1A

SCALE: NTS

MOORE AND ASSOCIATES
ENGINEERING AND CONSULTING, INC.

DRAWN BY: LT

CHECKED BY: PDM

PROJECT MGR: WSM

CLIENT: TOL

TOL BUILDINGS, INC.

P.O. BOX 542

TOAST, NC 27049

30'-0" x 20'-0" ENCLOSED STRUCTURE

DATE: 3-21-22

SHT. 6G

SCALE: NTS

DWG. NO: SK-3

JOB NO:

19164S/22020S

REV: 1

THIS DOCUMENT IS THE PROPERTY OF MOORE AND ASSOCIATES ENGINEERING AND CONSULTING. THE UNAUTHORIZED REPRODUCTION, COPYING, OR OTHERWISE USE OF THIS DOCUMENT IS STRICTLY PROHIBITED AND ANY INFRINGEMENT THEREUPON MAY BE SUBJECT TO LEGAL ACTION.

SL ≤ 60 PSF
EXPOSURE B/C

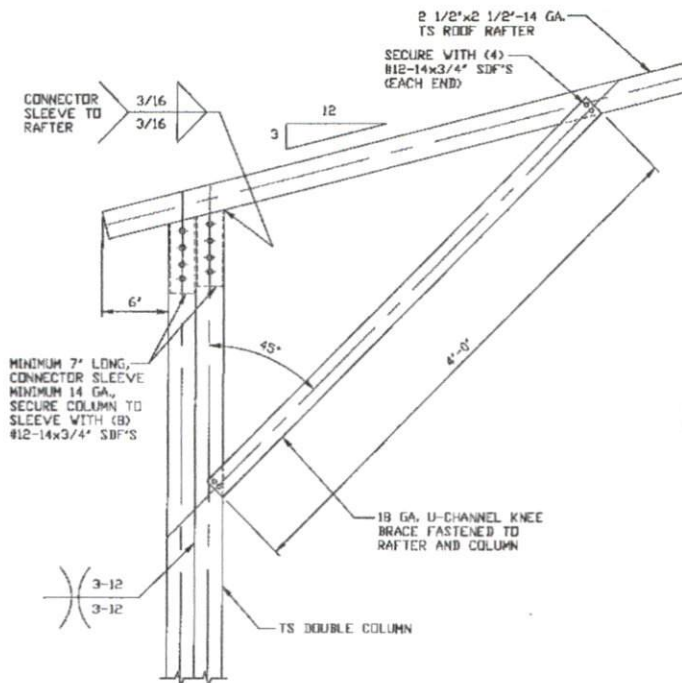

BOX EAVE RAFTER COLUMN CONNECTION DETAIL FOR HEIGHTS 12'-0" < TO ≤ 16'-0" HEIGHTS 11'-0" < TO ≤ 15'-0" FOR APPLICABLE WIND RISK CATEGORY WIND SPEEDS

1B

SCALE: NTS

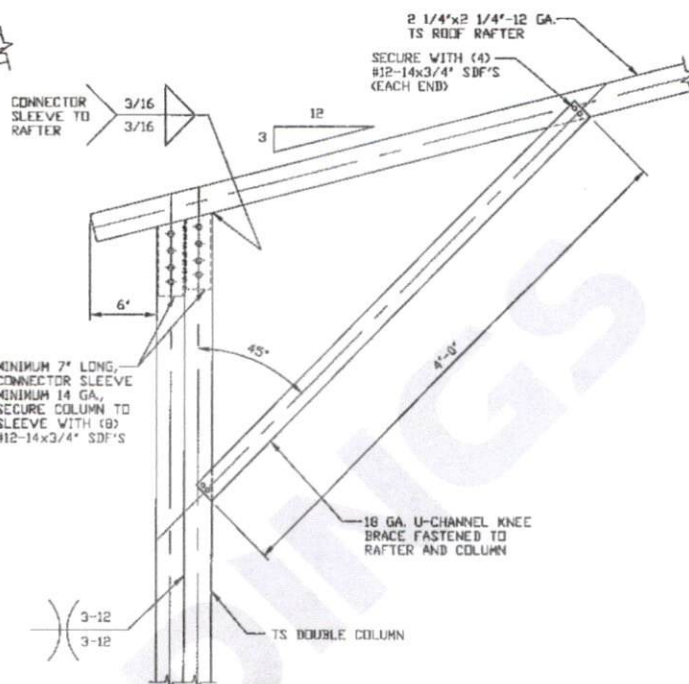

BOX EAVE RAFTER COLUMN CONNECTION DETAIL FOR HEIGHTS 12'-0" < TO ≤ 16'-0" HEIGHTS 11'-0" < TO ≤ 15'-0" FOR APPLICABLE RISK CATEGORY WIND SPEEDS

1C

SCALE: NTS

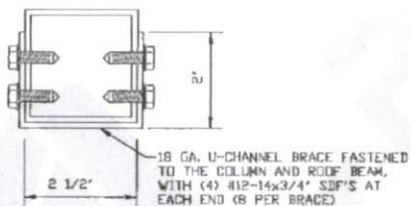

BRACE SECTION

SCALE: NTS

MOORE AND ASSOCIATES ENGINEERING AND CONSULTING, INC.

DRAWN BY: LT

CHECKED BY: PDH

PROJECT MGR: VSM

CLIENT: TOL

TOL BUILDINGS, INC.
P.O. BOX 542
TOAST, NC 27049
30'-0" x 20'-0" ENCLOSED STRUCTURE

DATE: 3-21-22

SHT. 6H

SCALE: NTS

DWG. NO: SK-3

JOB NO: 19164S/22020S

REV. 1

THIS DOCUMENT IS THE PROPERTY OF MOORE AND ASSOCIATES ENGINEERING AND CONSULTING. THE UNAUTHORIZED REPRODUCTION, COPYING, OR OTHERWISE USE OF THIS DOCUMENT IS STRICTLY PROHIBITED AND ANY INFRINGEMENT THEREUPON MAY BE SUBJECT TO LEGAL ACTION.

**SL ≤ 60 PSF
EXPOSURE B/C**

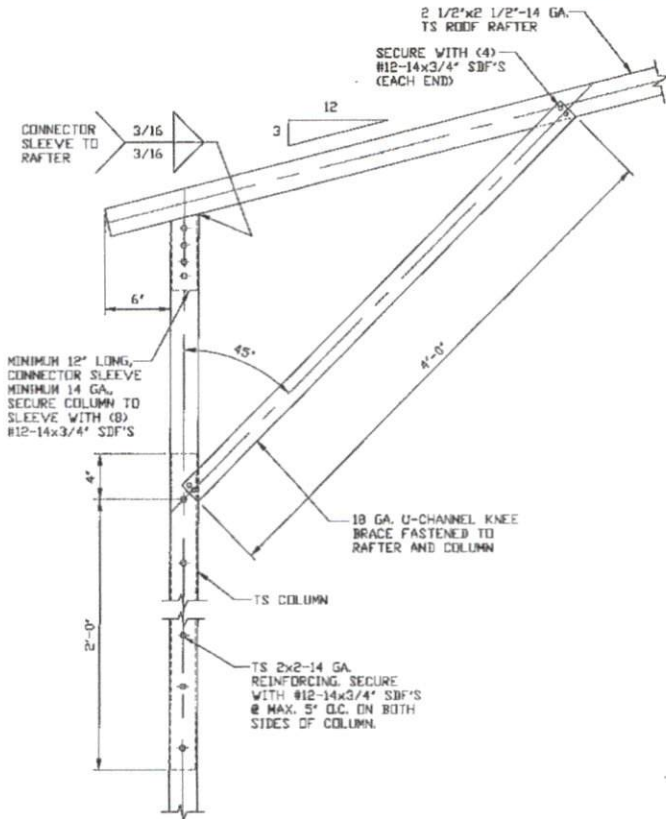

BOX EAVE RAFTER COLUMN CONNECTION DETAIL FOR HEIGHTS 11'-0" < TO ≤ 12'-0" HEIGHTS 9'-0" < TO ≤ 11'-0" FOR APPLICABLE RISK CATEGORY WIND SPEEDS

1D
SCALE: NTS

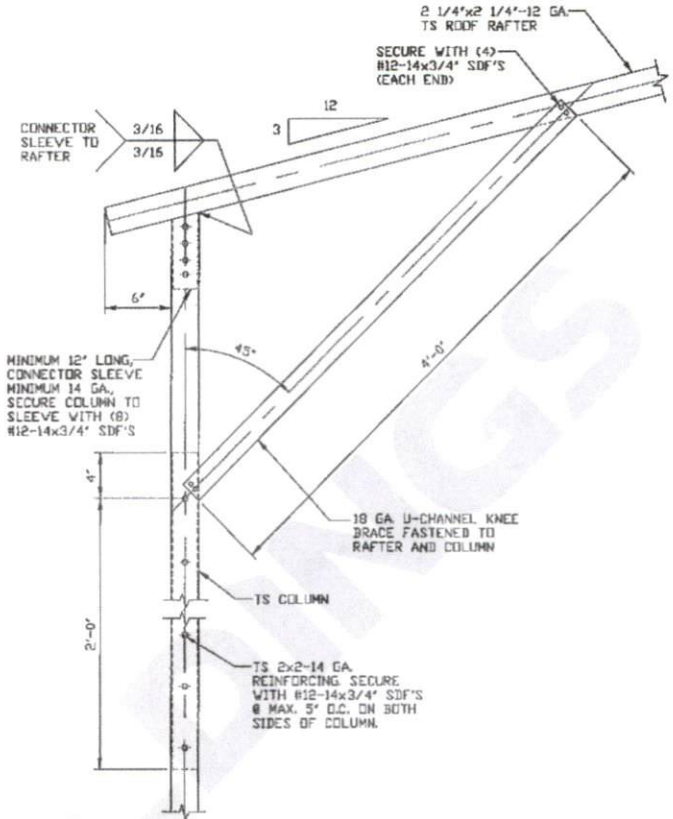

BOX EAVE RAFTER COLUMN CONNECTION DETAIL FOR HEIGHTS 11'-0" < TO ≤ 12'-0" HEIGHTS 9'-0" < TO ≤ 11'-0" FOR APPLICABLE RISK CATEGORY WIND SPEEDS

1E
SCALE: NTS

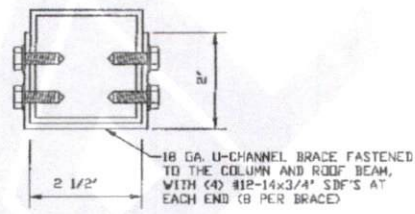

BRACE SECTION
SCALE: NTS

**MOORE AND ASSOCIATES
ENGINEERING AND CONSULTING, INC.**

DRAWN BY: LT
CHECKED BY: PDH
PROJECT MGR: VSM
CLIENT: TOL

TOL BUILDINGS, INC.
P.O. BOX 542
TOAST, NC 27049
30'-0" x 20'-0" ENCLOSED STRUCTURE
DATE: 3-21-22
SCALE: NTS
SHT. 6J
DWG. NO: SK-3
JOB NO: 19164S/2R020S
REV: 1

THIS DOCUMENT IS THE PROPERTY OF MOORE AND ASSOCIATES ENGINEERING AND CONSULTING. THE UNAUTHORIZED REPRODUCTION, COPYING, OR OTHERWISE USE OF THIS DOCUMENT IS STRICTLY PROHIBITED AND ANY INFRINGEMENT THEREUPON MAY BE SUBJECT TO LEGAL ACTION.

SL ≤ 60 PSF
EXPOSURE B/C

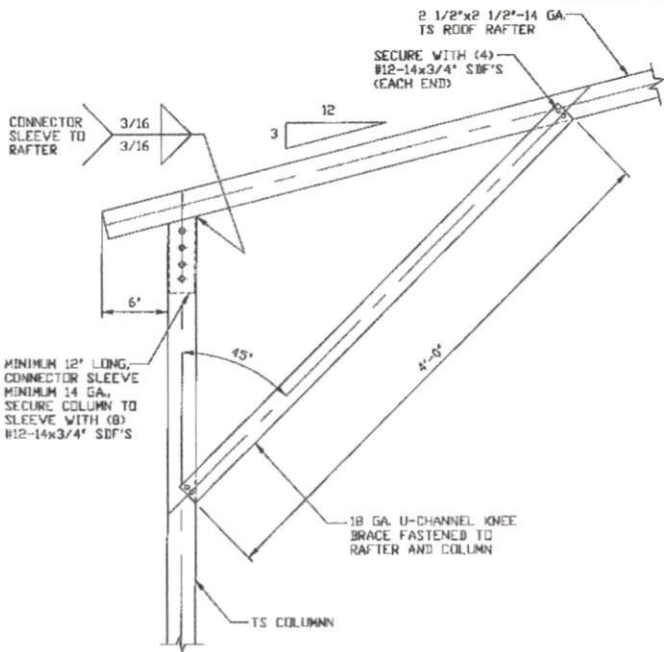

BOX EAVE RAFTER COLUMN CONNECTION DETAIL FOR HEIGHTS ≤ 11'-0\" HEIGHTS ≤ 9'-0\" FOR APPLICABLE RISK CATEGORY WIND SPEEDS

1F

SCALE: NTS

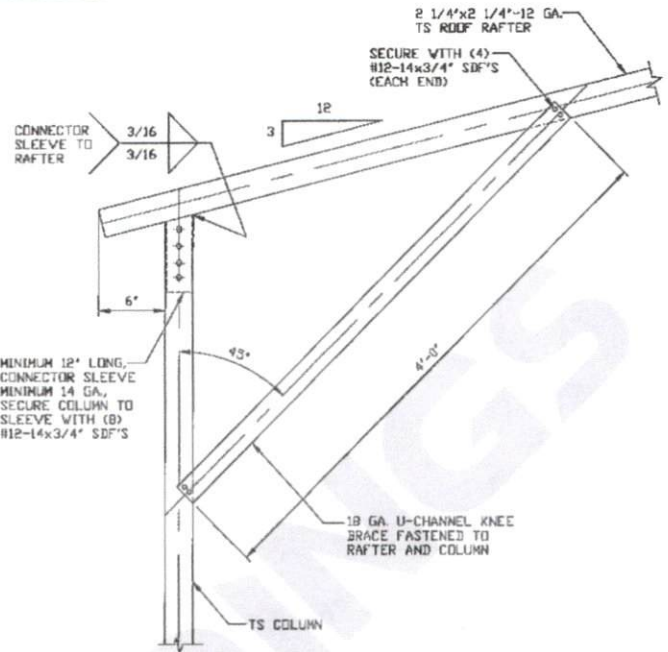

BOX EAVE RAFTER COLUMN CONNECTION DETAIL FOR HEIGHTS ≤ 11'-0\" HEIGHTS ≤ 9'-0\" FOR APPLICABLE RISK CATEGORY WIND SPEEDS

1G

SCALE: NTS

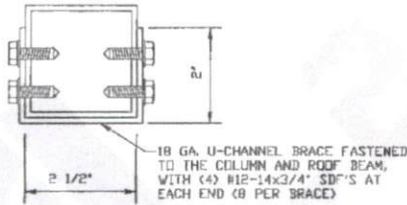

BRACE SECTION

SCALE: NTS

MOORE AND ASSOCIATES ENGINEERING AND CONSULTING, INC.

DRAWN BY: LT

CHECKED BY: PDH

PROJECT MGR: WSM

CLIENT: TOL

TOL BUILDINGS, INC.
P.O. BOX 542
TOAST, NC 27049

30'-0\" x 20'-0\" ENCLOSED STRUCTURE

DATE: 3-21-22

SHT. 6K

SCALE: NTS

DWG. NO SK-3

JOB NO: 19164S/22020S

REV: 1

THIS DOCUMENT IS THE PROPERTY OF MOORE AND ASSOCIATES ENGINEERING AND CONSULTING. THE UNAUTHORIZED REPRODUCTION, COPYING, OR OTHERWISE USE OF THIS DOCUMENT IS STRICTLY PROHIBITED AND ANY INFRINGEMENT THEREUPON MAY BE SUBJECT TO LEGAL ACTION.

SL ≤ 30 PSF
EXPOSURE B/C

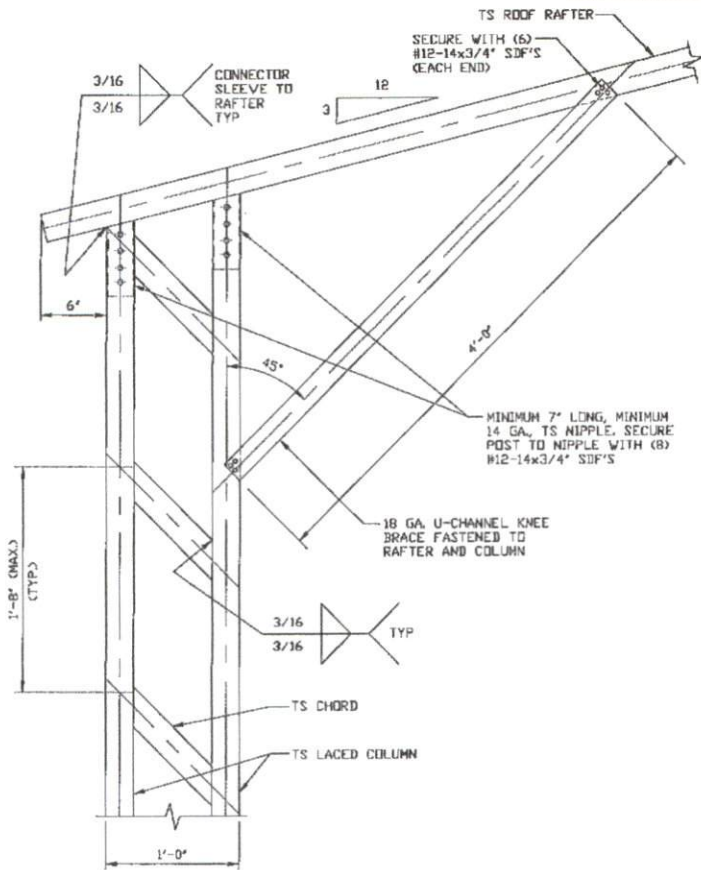

BOX EAVE RAFTER COLUMN CONNECTION DETAIL FOR HEIGHTS 12'-0" < TO ≤ 16'-0" HEIGHTS 15'-0" < TO ≤ 20'-0" FOR APPLICABLE RISK CATEGORY WIND SPEEDS

1

SCALE: NTS

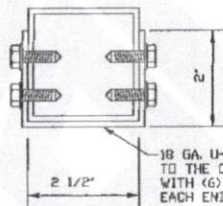

BRACE SECTION
SCALE: NTS

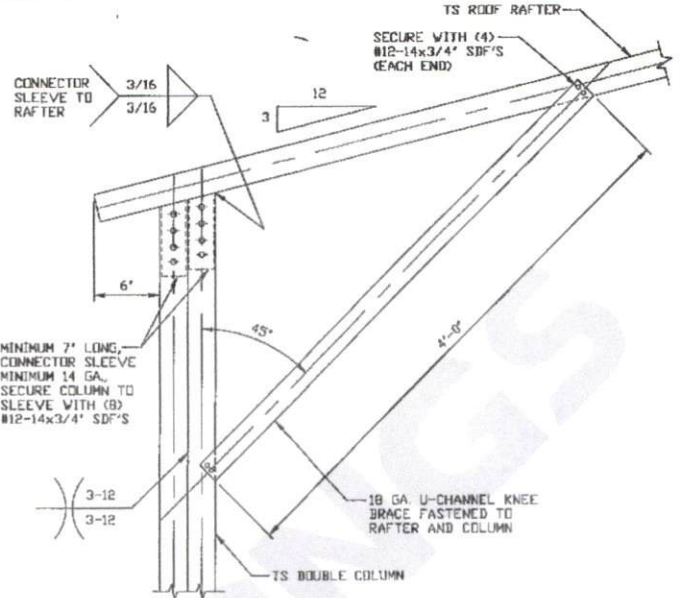

BOX EAVE RAFTER COLUMN CONNECTION DETAIL FOR HEIGHTS 11'-0" < TO ≤ 16'-0" HEIGHTS 11'-0" < TO ≤ 15'-0" FOR APPLICABLE RISK CATEGORY WIND SPEEDS

1A

SCALE: NTS

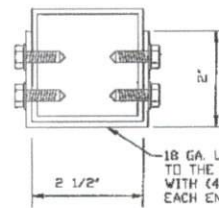

BRACE SECTION
SCALE: NTS

MOORE AND ASSOCIATES ENGINEERING AND CONSULTING, INC.

DRAWN BY: LT

CHECKED BY: PDH

PROJECT MGR: WSM

CLIENT: TOL

TOL BUILDINGS, INC.
P.O. BOX 542
TOAST, NC 27049
30'-0" x 20'-0" ENCLOSED STRUCTURE

DATE: 3-21-22

SHT. 6L

SCALE: NTS

DWG. NO: SK-3

JOB NO: 19164S/22020S

REV: 1

THIS DOCUMENT IS THE PROPERTY OF MOORE AND ASSOCIATES ENGINEERING AND CONSULTING. THE UNAUTHORIZED REPRODUCTION, COPYING, OR OTHERWISE USE OF THIS DOCUMENT IS STRICTLY PROHIBITED AND ANY INFRINGEMENT THEREUPON MAY BE SUBJECT TO LEGAL ACTION.

SL ≤ 30 PSF
EXPOSURE B/C

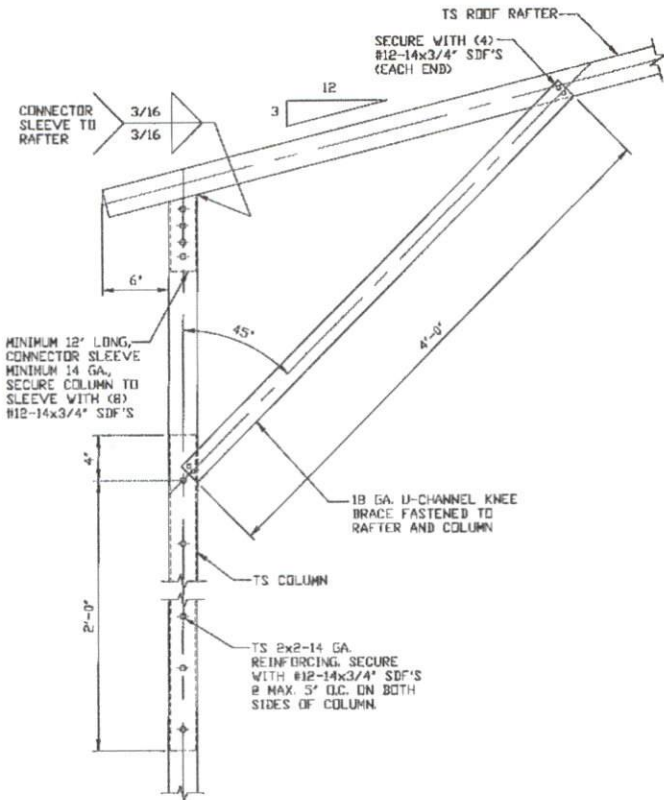

1B

BOX EAVE RAFTER COLUMN CONNECTION DETAIL FOR HEIGHTS 11'-0" < TO ≤ 12'-0" HEIGHTS 9'-0" < TO ≤ 11'-0" FOR APPLICABLE RISK CATEGORY WIND SPEEDS

SCALE: NTS

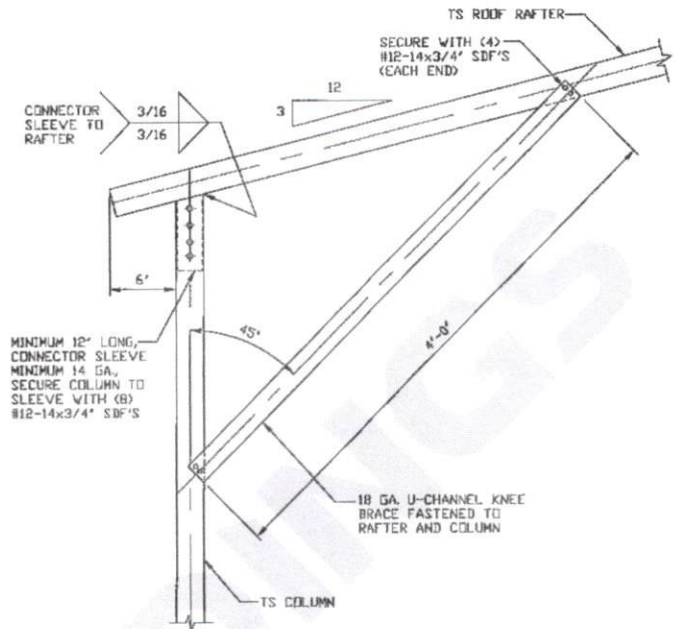

1C

BOX EAVE RAFTER COLUMN CONNECTION DETAIL FOR HEIGHTS ≤ 11'-0" HEIGHTS ≤ 9'-0" FOR APPLICABLE RISK CATEGORY WIND SPEEDS

SCALE: NTS

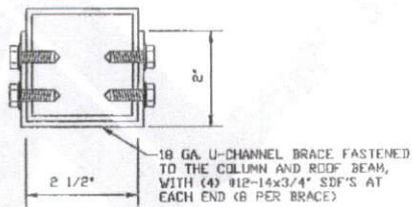

BRACE SECTION

SCALE: NTS

MOORE AND ASSOCIATES ENGINEERING AND CONSULTING, INC.

DRAWN BY: LT

CHECKED BY: PDH

PROJECT MGR: WSN

CLIENT: TOL

TOL BUILDINGS, INC.
P.O. BOX 542
TOAST, NC 27049
30'-0" x 20'-0" ENCLOSED STRUCTURE

DATE: 3-21-22

SHT. 6H

SCALE: NTS

DWG. NO: SK-3

JOB NO: 19164S/22020S

REV: 1

THIS DOCUMENT IS THE PROPERTY OF MOORE AND ASSOCIATES ENGINEERING AND CONSULTING. THE UNAUTHORIZED REPRODUCTION, COPYING, OR OTHERWISE USE OF THIS DOCUMENT IS STRICTLY PROHIBITED AND ANY INFRINGEMENT THEREUPON MAY BE SUBJECT TO LEGAL ACTION.

60 PSF < SL ≤ 70 PSF

EXPOSURE B

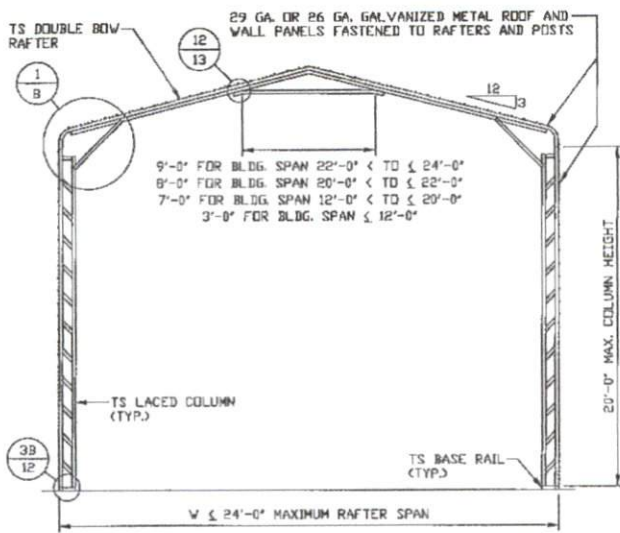

TYPICAL RAFTER/COLUMN END FRAME SECTION
SCALE: NTS

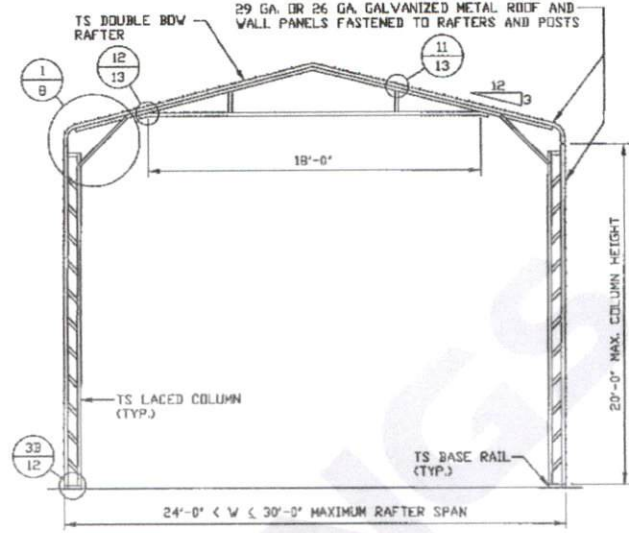

TYPICAL RAFTER/COLUMN END FRAME SECTION
SCALE: NTS

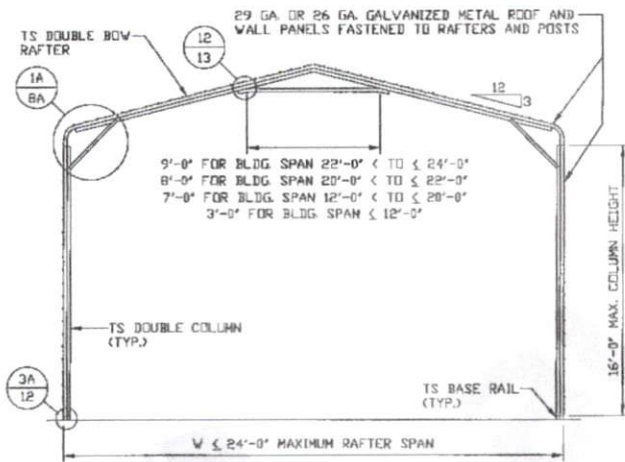

TYPICAL RAFTER/COLUMN END FRAME SECTION
SCALE: NTS

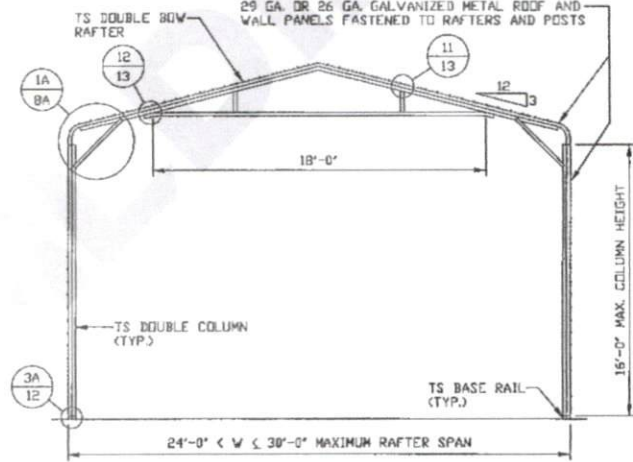

TYPICAL RAFTER/COLUMN END FRAME SECTION
SCALE: NTS

**MOORE AND ASSOCIATES
ENGINEERING AND CONSULTING, INC.**

DRAWN BY: LT
CHECKED BY: PDH

TOL BUILDINGS, INC.
P.O. BOX 542
TOAST, NC 27049
30'-0" X 20'-0" ENCLOSED STRUCTURE

THIS DOCUMENT IS THE PROPERTY OF MOORE AND ASSOCIATES ENGINEERING AND CONSULTING. THE UNAUTHORIZED REPRODUCTION, COPYING, OR OTHERWISE USE OF THIS DOCUMENT IS STRICTLY PROHIBITED AND ANY INFRINGEMENT THEREUPON MAY BE SUBJECT TO LEGAL ACTION.

PROJECT MGR: VSH
CLIENT: TOL

DATE: 3-21-22
SHT. 7

SCALE: NTS
DWG. NO: SK-3

JOB NO: 19164S/22020S
REV: 1

60 PSF < SL ≤ 70 PSF
EXPOSURE B

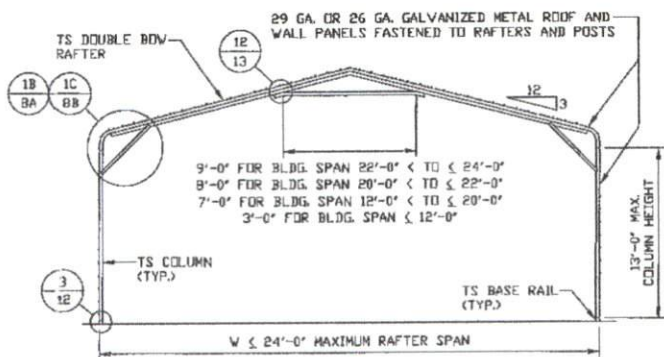

TYPICAL RAFTER/COLUMN END FRAME SECTION
SCALE: NTS

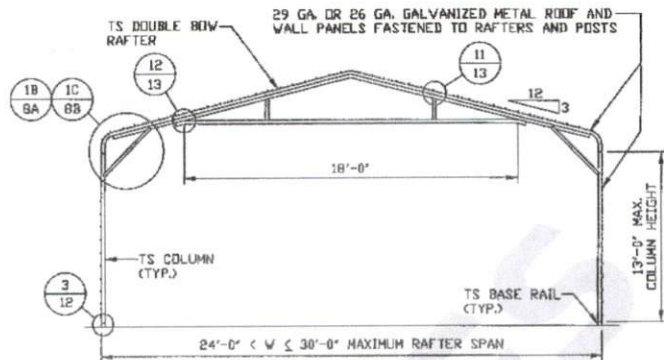

TYPICAL RAFTER/COLUMN END FRAME SECTION
SCALE: NTS

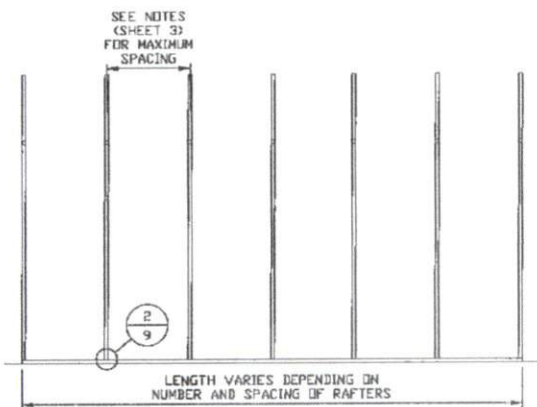

TYPICAL RAFTER/COLUMN SIDE FRAMING SECTION
SCALE: NTS

**MOORE AND ASSOCIATES
ENGINEERING AND CONSULTING, INC.**

DRAWN BY: LT

CHECKED BY: PDH

PROJECT MGR: WSM

CLIENT: TOL

TOL BUILDINGS, INC.
P.O. BOX 542
TOAST, NC 27049
30'-0" x 20'-0" ENCLOSED STRUCTURE

DATE: 3-21-22

SHT. 7A

SCALE: NTS

DWG. NO. SK-3

JOB NO.
19164S/22020S

REV: 1

THIS DOCUMENT IS THE PROPERTY OF MOORE AND ASSOCIATES ENGINEERING AND CONSULTING. THE UNAUTHORIZED REPRODUCTION, COPYING, OR OTHERWISE USE OF THIS DOCUMENT IS STRICTLY PROHIBITED AND ANY INFRINGEMENT THEREUPON MAY BE SUBJECT TO LEGAL ACTION.

60 PSF < SL ≤ 70 PSF

EXPOSURE C

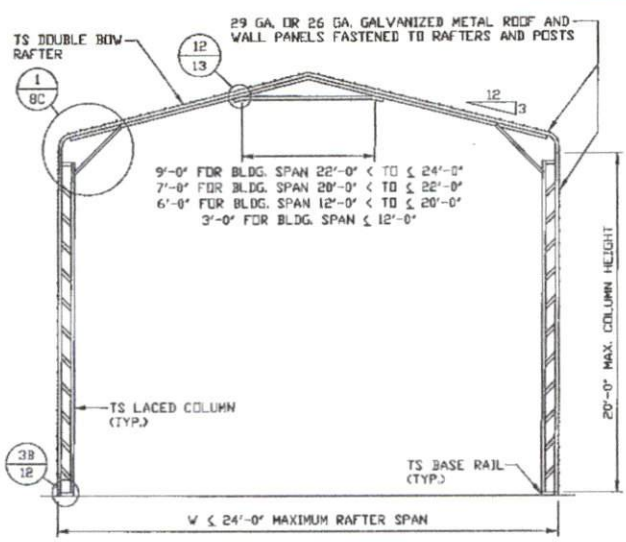

TYPICAL RAFTER/COLUMN END FRAME SECTION
SCALE: NTS

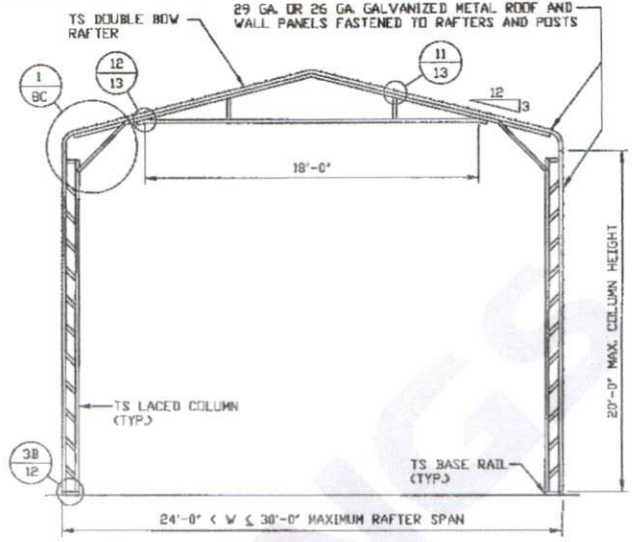

TYPICAL RAFTER/COLUMN END FRAME SECTION
SCALE: NTS

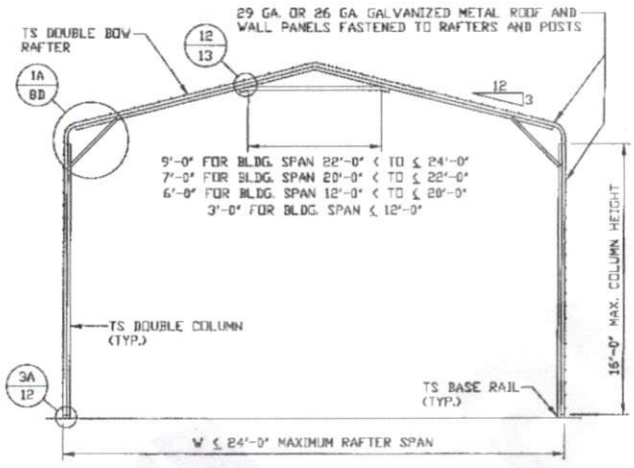

TYPICAL RAFTER/COLUMN END FRAME SECTION
SCALE: NTS

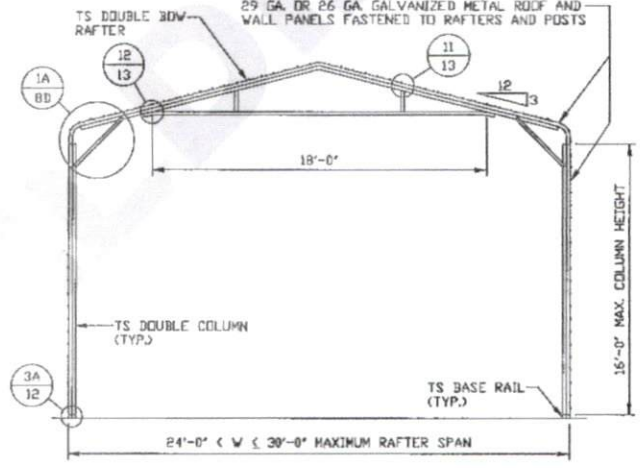

TYPICAL RAFTER/COLUMN END FRAME SECTION
SCALE: NTS

MOORE AND ASSOCIATES
ENGINEERING AND CONSULTING, INC.

DRAWN BY: LT
CHECKED BY: PDH

TOL BUILDINGS, INC.
P.O. BOX 542
TOAST, NC 27049
30'-0"x20'-0" ENCLOSED STRUCTURE

THIS DOCUMENT IS THE PROPERTY OF MOORE AND ASSOCIATES ENGINEERING AND CONSULTING. THE UNAUTHORIZED REPRODUCTION, COPYING, OR OTHERWISE USE OF THIS DOCUMENT IS STRICTLY PROHIBITED AND ANY INFRINGEMENT THEREUPON MAY BE SUBJECT TO LEGAL ACTION.

PROJECT MGR: VSM
CLIENT: TOL

DATE: 3-21-22
SHT. 7B

SCALE: NTS
DWG. NO: SK-3

JOB NO: 19164S/22080S
REV: 1

60 PSF < SL ≤ 70 PSF
EXPOSURE C

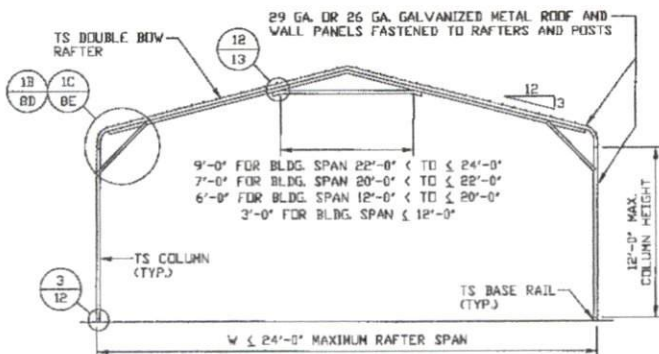

TYPICAL RAFTER/COLUMN END FRAME SECTION
SCALE: NTS

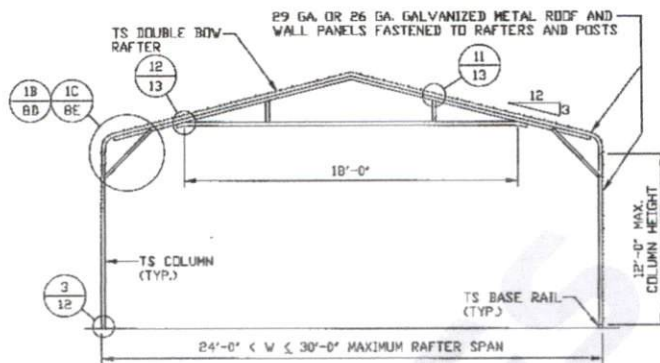

TYPICAL RAFTER/COLUMN SIDE FRAMING SECTION
SCALE: NTS

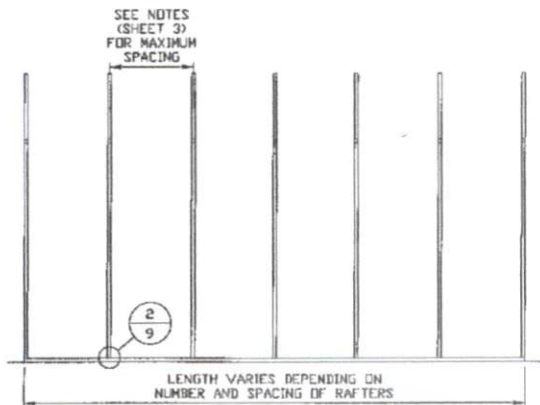

TYPICAL RAFTER/COLUMN SIDE FRAMING SECTION
SCALE: NTS

MOORE AND ASSOCIATES
ENGINEERING AND CONSULTING, INC.

DRAWN BY: LT

CHECKED BY: PDH

PROJECT MGR: WSM

CLIENT: TOL

TOL BUILDINGS, INC.

P.O. BOX 542

TOAST, NC 27049

30'-0" x 20'-0" ENCLOSED STRUCTURE

DATE: 3-21-22

SHT. 7C

SCALE: NTS

DWG. NO SK-3

JOB NO.
19164S/22020S

REV: 1

THIS DOCUMENT IS THE PROPERTY OF MOORE AND ASSOCIATES ENGINEERING AND CONSULTING. THE UNAUTHORIZED REPRODUCTION, COPYING, OR OTHERWISE USE OF THIS DOCUMENT IS STRICTLY PROHIBITED AND ANY INFRINGEMENT THEREUPON MAY BE SUBJECT TO LEGAL ACTION.

SL ≤ 60 PSF
EXPOSURE B/C

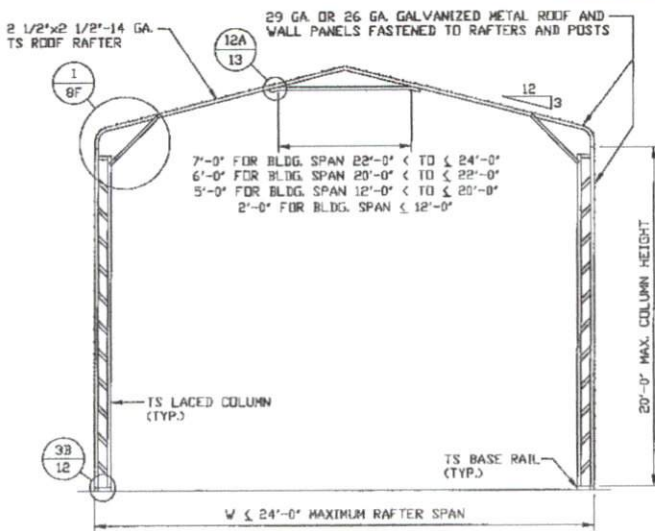

TYPICAL RAFTER/COLUMN END FRAME SECTION
SCALE: NTS

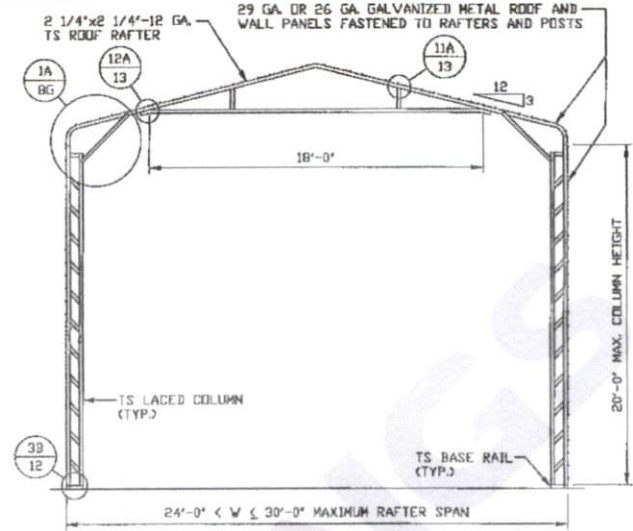

TYPICAL RAFTER/COLUMN END FRAME SECTION
SCALE: NTS

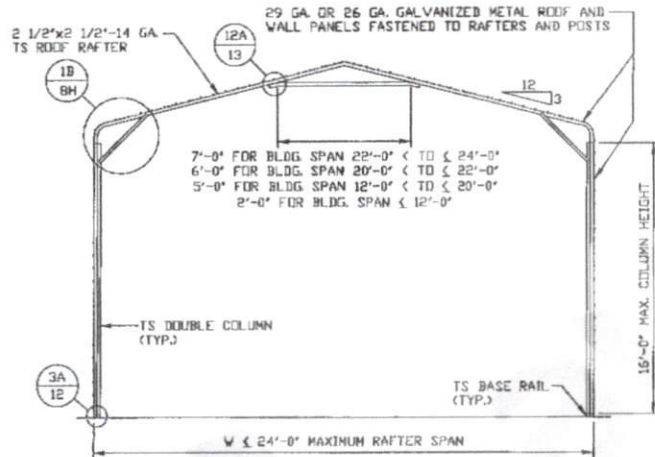

TYPICAL RAFTER/COLUMN END FRAME SECTION
SCALE: NTS

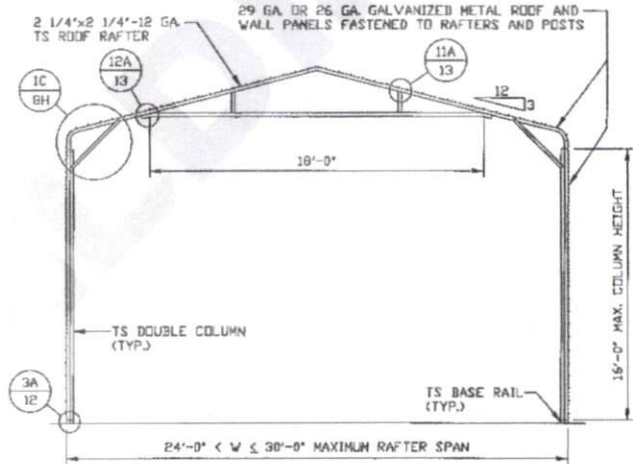

TYPICAL RAFTER/COLUMN END FRAME SECTION
SCALE: NTS

**MOORE AND ASSOCIATES
ENGINEERING AND CONSULTING, INC.**

DRAWN BY: LT

CHECKED BY: PJH

PROJECT MGR: WSM

CLIENT: TOL

TOL BUILDINGS, INC.
P.O. BOX 542
TOAST, NC 27049
30'-0" x 20'-0" ENCLOSED STRUCTURE

DATE: 3-21-22

SCALE: NTS

DWG. NO: SK-3

JOB NO:
19164S/22020S

REV: 1

THIS DOCUMENT IS THE PROPERTY OF MOORE AND ASSOCIATES ENGINEERING AND CONSULTING. THE UNAUTHORIZED REPRODUCTION, COPYING, OR OTHERWISE USE OF THIS DOCUMENT IS STRICTLY PROHIBITED AND ANY INFRINGEMENT THEREUPON MAY BE SUBJECT TO LEGAL ACTION.

SL ≤ 60 PSF
EXPOSURE B/C

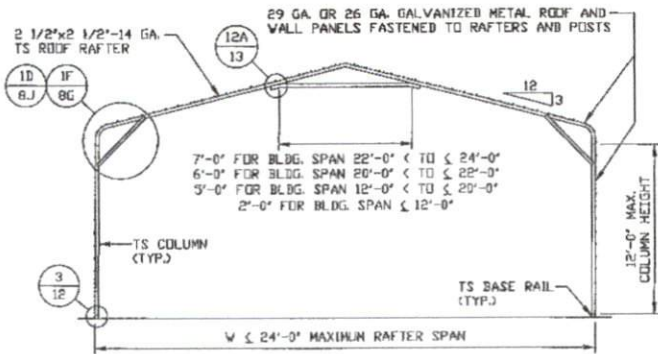

TYPICAL RAFTER/COLUMN END FRAME SECTION

SCALE: NTS

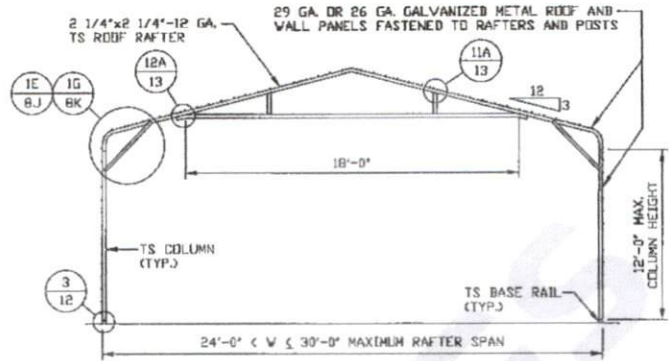

TYPICAL RAFTER/COLUMN END FRAME SECTION

SCALE: NTS

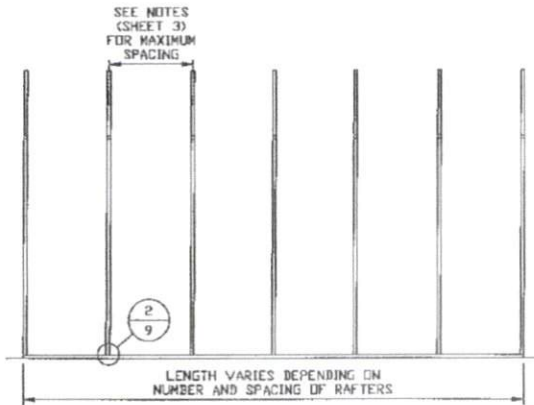

TYPICAL RAFTER/COLUMN SIDE FRAMING SECTION

SCALE: NTS

**MOORE AND ASSOCIATES
ENGINEERING AND CONSULTING, INC.**

DRAWN BY: LT

CHECKED BY: PDH

PROJECT MGR: VSM

CLIENT: TOL

TOL BUILDINGS, INC.
P.O. BOX 542
TOAST, NC 27049
30'-0" x 20'-0" ENCLOSED STRUCTURE

DATE: 3-21-22

SHT. 7E

SCALE: NTS

DWG. NO. SK-3

JOB NO:
19164S/22020S

REV: 1

THIS DOCUMENT IS THE PROPERTY OF MOORE AND ASSOCIATES ENGINEERING AND CONSULTING. THE UNAUTHORIZED REPRODUCTION, COPYING, OR OTHERWISE USE OF THIS DOCUMENT IS STRICTLY PROHIBITED AND ANY INFRINGEMENT THEREUPON MAY BE SUBJECT TO LEGAL ACTION.

SL ≤ 30 PSF
EXPOSURE B/C

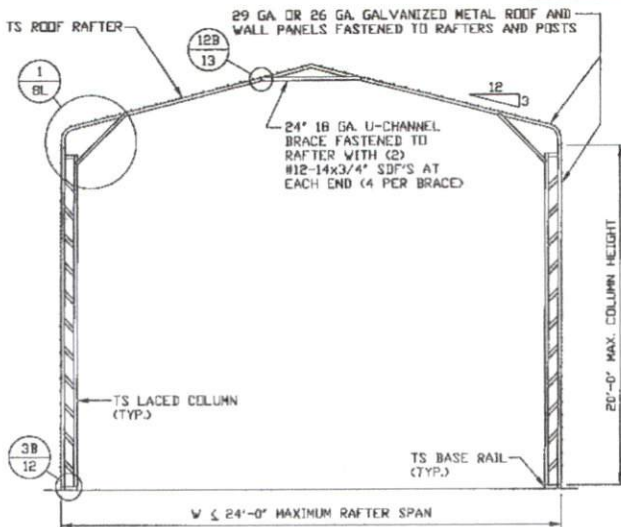

TYPICAL RAFTER/COLUMN END FRAME SECTION
SCALE: NTS

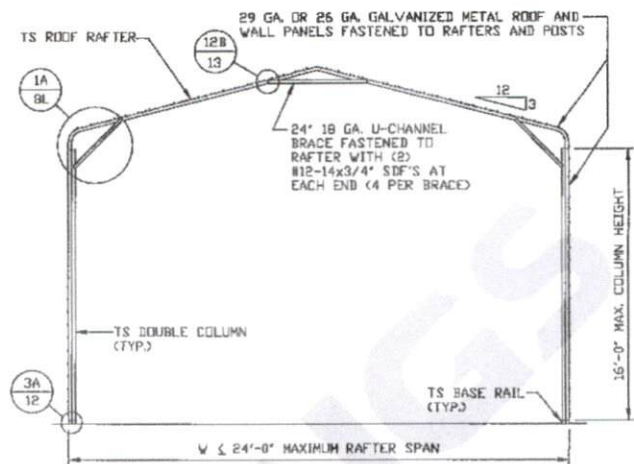

TYPICAL RAFTER/COLUMN END FRAME SECTION
SCALE: NTS

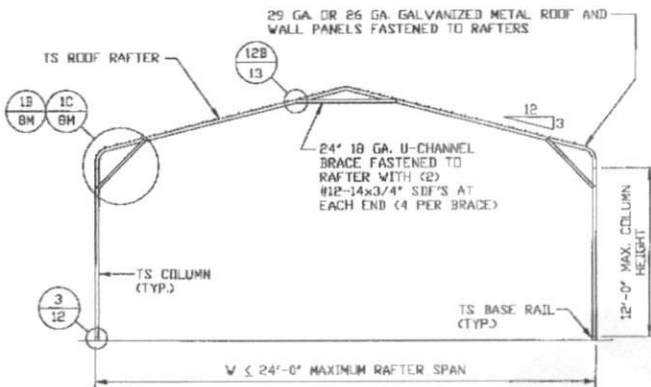

TYPICAL RAFTER/COLUMN END FRAME SECTION
SCALE: NTS

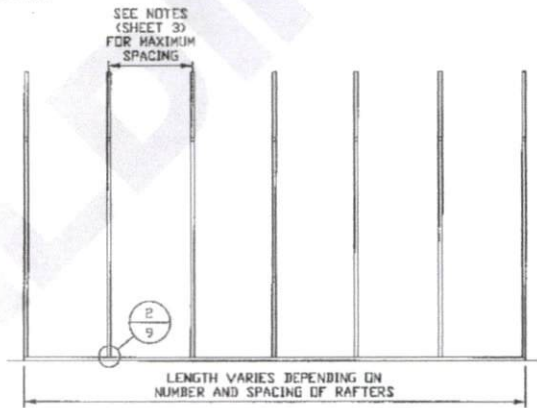

TYPICAL RAFTER/COLUMN SIDE FRAMING SECTION
SCALE: NTS

**MOORE AND ASSOCIATES
ENGINEERING AND CONSULTING, INC.**

DRAWN BY: LT
CHECKED BY: PDH

TOL BUILDINGS, INC.
P.O. BOX 542
TOAST, NC 27049
30'-0" x 20'-0" ENCLOSED STRUCTURE

THIS DOCUMENT IS THE PROPERTY OF MOORE AND ASSOCIATES ENGINEERING AND CONSULTING. THE UNAUTHORIZED REPRODUCTION, COPYING, OR OTHERWISE USE OF THIS DOCUMENT IS STRICTLY PROHIBITED AND ANY INFRINGEMENT THEREUPON MAY BE SUBJECT TO LEGAL ACTION.

PROJECT MGR: WSH
CLIENT: TOL

DATE: 3-21-22
SHT. 7F

SCALE: NTS
DWG. NO: SK-3

JOB NO: 19164S/22020S
REV: 1

60 PSF < SL ≤ 70 PSF

EXPOSURE B

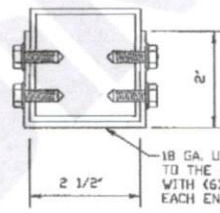
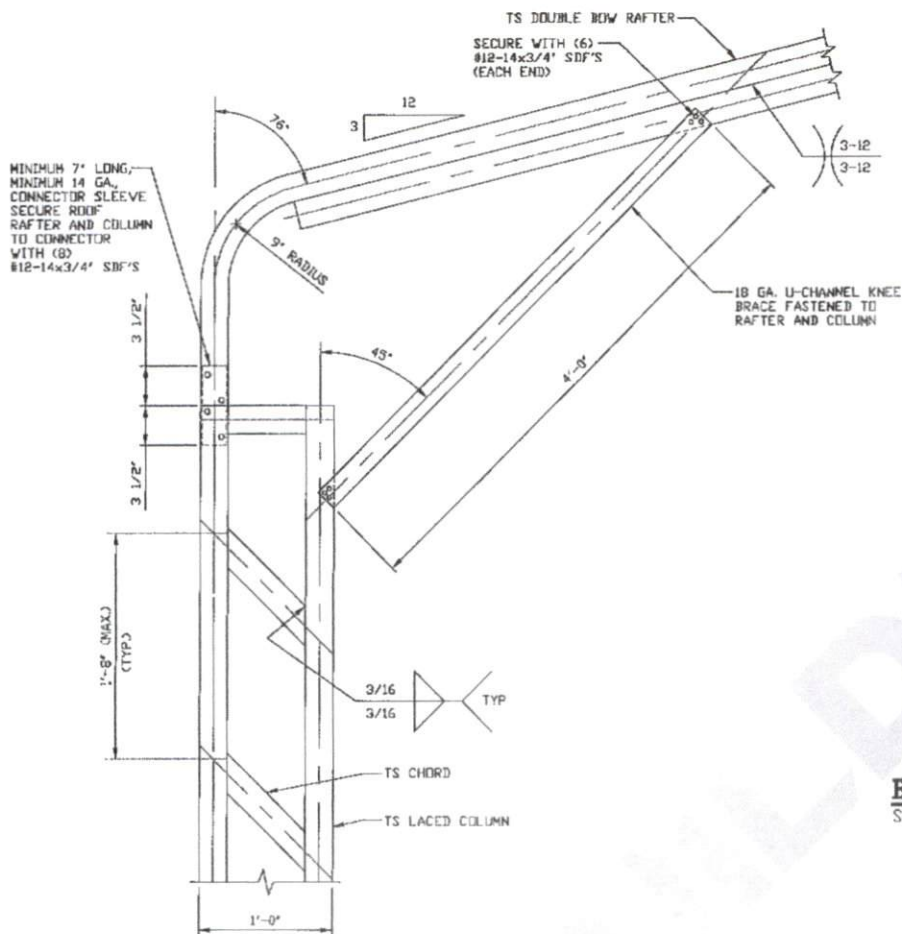

BRACE SECTION

SCALE: NTS

**BOW EAVE RAFTER COLUMN CONNECTION DETAIL
FOR HEIGHTS 16'-0" < TO ≤ 20'-0"
HEIGHTS 15'-0" < TO ≤ 20'-0"
FOR APPLICABLE RISK CATEGORY WIND SPEEDS**

1

SCALE: NTS

**MOORE AND ASSOCIATES
ENGINEERING AND CONSULTING, INC.**

DRAWN BY: LT
CHECKED BY: PDH

TOL BUILDINGS, INC.
P.O. BOX 542
TOAST, NC 27049
30'-0"x20'-0" ENCLOSED STRUCTURE

THIS DOCUMENT IS THE PROPERTY OF MOORE AND ASSOCIATES ENGINEERING AND CONSULTING. THE UNAUTHORIZED REPRODUCTION, COPYING, OR OTHERWISE USE OF THIS DOCUMENT IS STRICTLY PROHIBITED AND ANY INFRINGEMENT THEREUPON MAY BE SUBJECT TO LEGAL ACTION.

PROJECT MGR: WSH
CLIENT: TOL

DATE: 3-21-22
SHT. 8

SCALE: NTS
DWG. NO: SK-3
JOB NO: 19164S/22020S
REV: 1

60 PSF < SL ≤ 70 PSF

EXPOSURE B

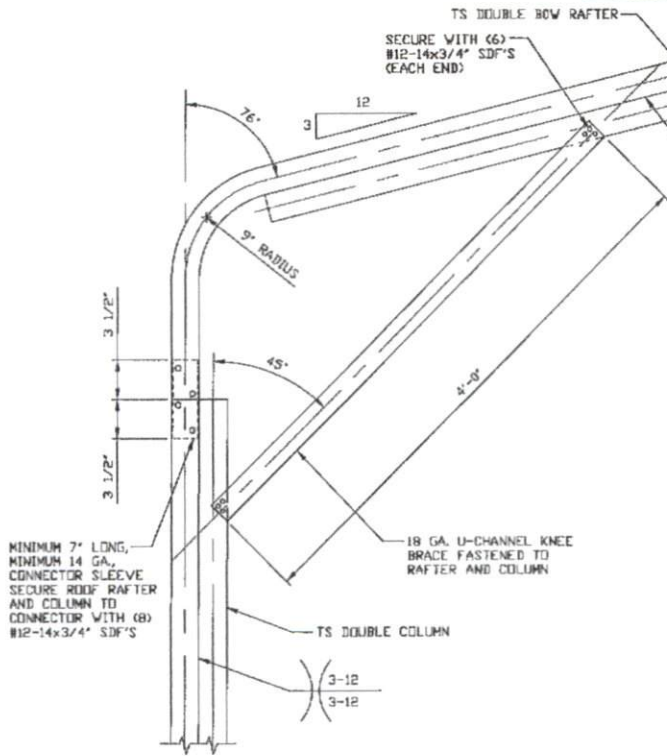

1A
SCALE: NTS
BOW EAVE RAFTER COLUMN CONNECTION DETAIL FOR HEIGHTS 13'-0" < TO ≤ 16'-0" HEIGHTS 11'-0" < TO ≤ 15'-0" FOR APPLICABLE RISK CATEGORY WIND SPEEDS

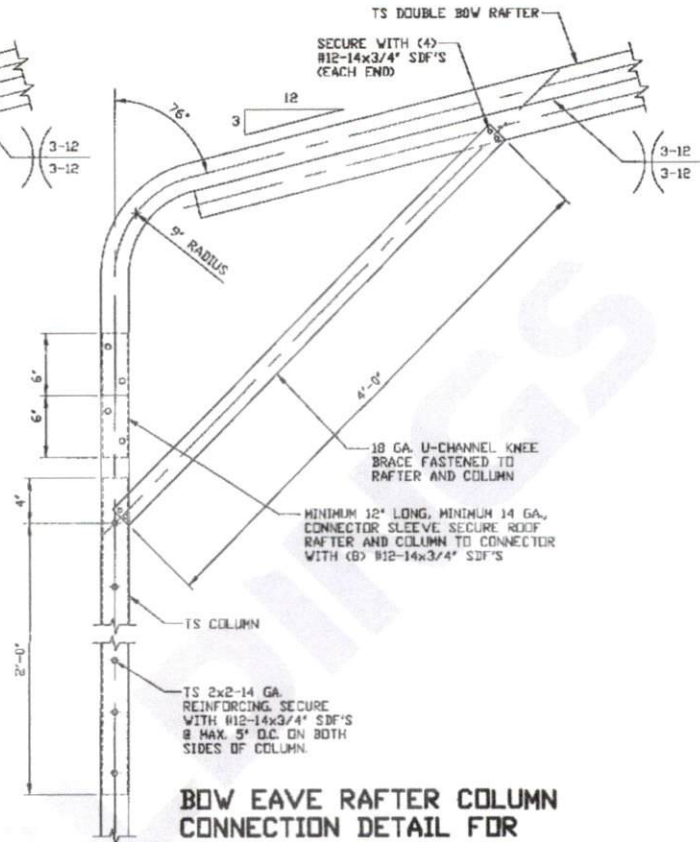

1B
SCALE: NTS
BOW EAVE RAFTER COLUMN CONNECTION DETAIL FOR HEIGHTS 11'-0" < TO ≤ 13'-0" HEIGHTS 9'-0" < TO ≤ 11'-0" FOR APPLICABLE RISK CATEGORY WIND SPEEDS

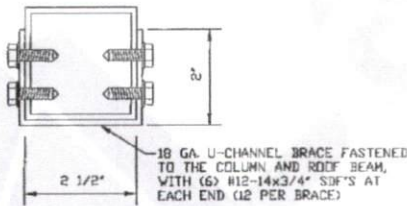

BRACE SECTION
SCALE: NTS

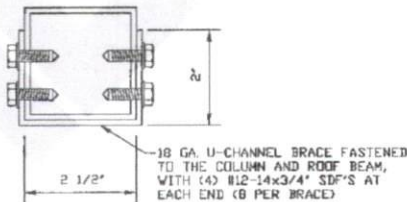

BRACE SECTION
SCALE: NTS

**MOORE AND ASSOCIATES
ENGINEERING AND CONSULTING, INC.**

DRAWN BY: LT

CHECKED BY: PDH

PROJECT MGR: WSM

CLIENT: TOL

TOL BUILDINGS, INC.
P.O. BOX 542
TOAST, NC 27049
30'-0" x 20'-0" ENCLOSED STRUCTURE

DATE: 3-21-22

SHT. 8A

SCALE: NTS

DWG. NO. SK-3

JOB NO. 19164S/22028S

REV. 1

THIS DOCUMENT IS THE PROPERTY OF MOORE AND ASSOCIATES ENGINEERING AND CONSULTING. THE UNAUTHORIZED REPRODUCTION, COPYING, OR OTHERWISE USE OF THIS DOCUMENT IS STRICTLY PROHIBITED AND ANY INFRINGEMENT THEREUPON MAY BE SUBJECT TO LEGAL ACTION.

60 PSF < SL ≤ 70 PSF

EXPOSURE B

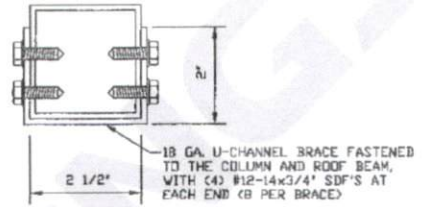
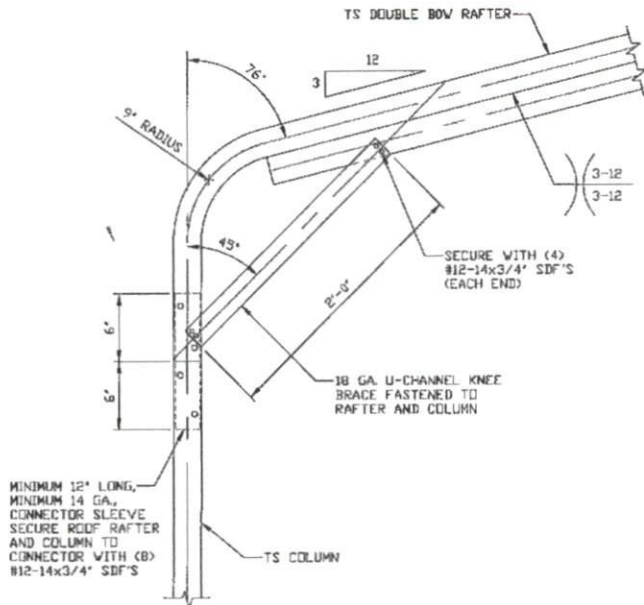

BRACE SECTION
SCALE: NTS

BOW EAVE RAFTER COLUMN CONNECTION DETAIL FOR HEIGHTS ≤ 11'-0" HEIGHTS ≤ 9'-0" FOR APPLICABLE RISK CATEGORY WIND SPEEDS

1C

SCALE: NTS

MOORE AND ASSOCIATES ENGINEERING AND CONSULTING, INC.

DRAWN BY: LT

CHECKED BY: PDH

PROJECT MGR: WSM

CLIENT: TOL

TOL BUILDINGS, INC.
P.O. BOX 542
TOAST, NC 27049
30'-0" x 20'-0" ENCLOSED STRUCTURE

DATE: 3-21-22

SHT. 88

SCALE: NTS

DWG. NO: SK-3

JOB NO: 19164S/22020S

REV: 1

THIS DOCUMENT IS THE PROPERTY OF MOORE AND ASSOCIATES ENGINEERING AND CONSULTING. THE UNAUTHORIZED REPRODUCTION, COPYING, OR OTHERWISE USE OF THIS DOCUMENT IS STRICTLY PROHIBITED AND ANY INFRINGEMENT THEREUPON MAY BE SUBJECT TO LEGAL ACTION.

60 PSF < SL ≤ 70 PSF
EXPOSURE C

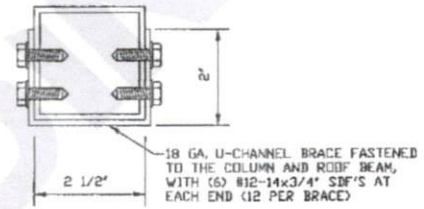
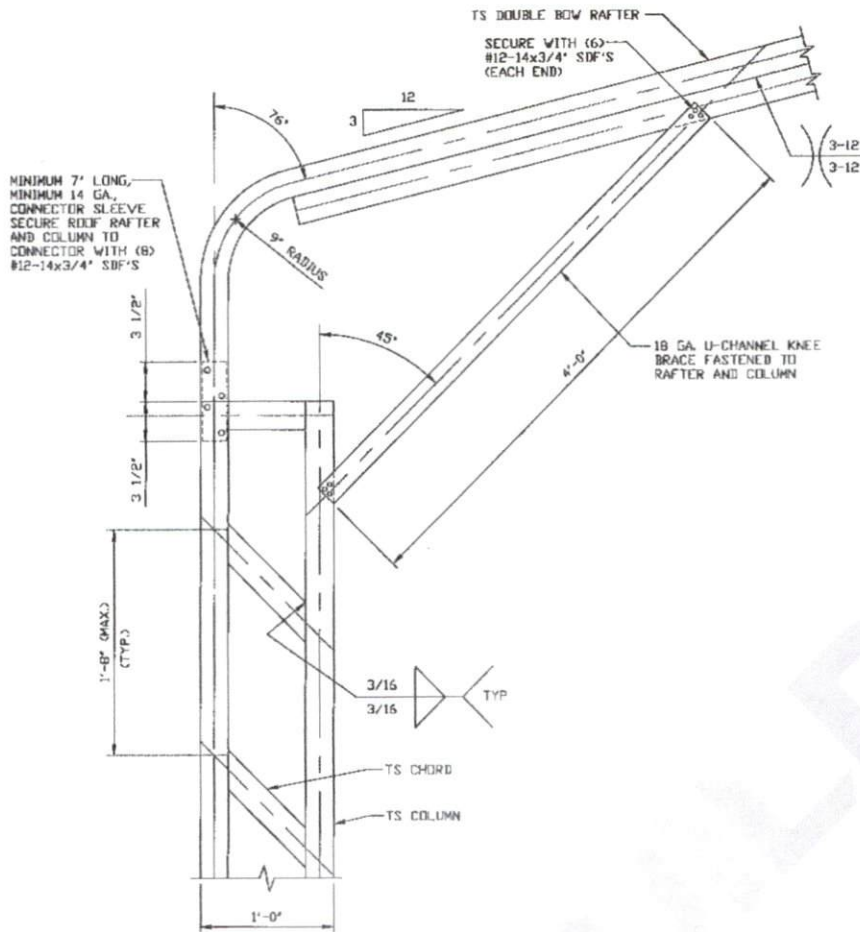

BRACE SECTION
SCALE: NTS

BOW EAVE RAFTER COLUMN CONNECTION DETAIL
FOR HEIGHTS 16'-0" < TO ≤ 20'-0"
HEIGHTS 14'-0" < TO ≤ 20'-0"
FOR APPLICABLE RISK CATEGORY WIND SPEEDS

1
SCALE: NTS

MOORE AND ASSOCIATES
ENGINEERING AND CONSULTING, INC.

DRAWN BY: LT

CHECKED BY: POH

PROJECT MGR: VSM

CLIENT: TOL

TOL BUILDINGS, INC.
P.O. BOX 542
TOAST, NC 27049
30'-0" x 20'-0" ENCLOSED STRUCTURE

DATE: 3-21-22

SHT. 8C

SCALE: NTS

DWG. NO. SK-3

JOB NO.
19164S/22020S

REV: 1

THIS DOCUMENT IS THE PROPERTY OF MOORE AND ASSOCIATES ENGINEERING AND CONSULTING. THE UNAUTHORIZED REPRODUCTION, COPYING, OR OTHERWISE USE OF THIS DOCUMENT IS STRICTLY PROHIBITED AND ANY INFRINGEMENT THEREUPON MAY BE SUBJECT TO LEGAL ACTION.

60 PSF < SL ≤ 70 PSF

EXPOSURE C

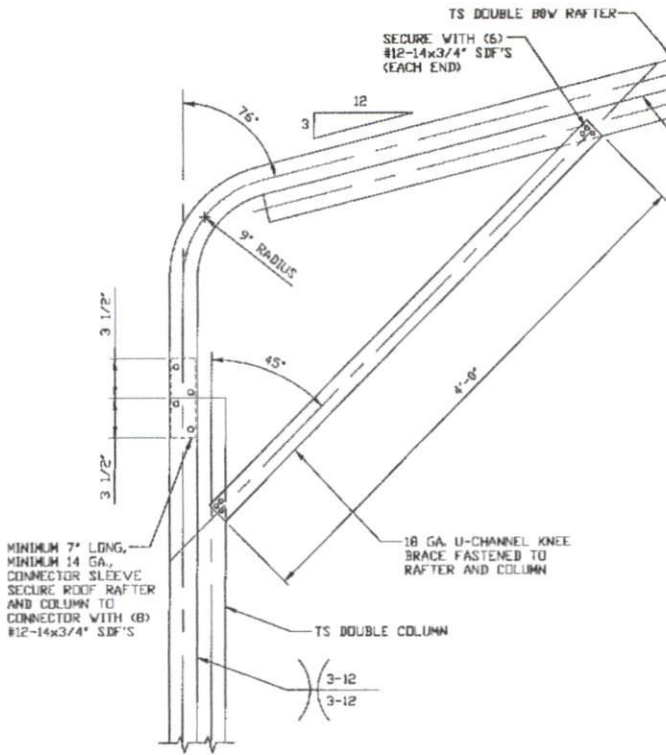

BOW EAVE RAFTER COLUMN CONNECTION DETAIL FOR HEIGHTS 12'-0" < TO ≤ 16'-0" HEIGHTS 10'-0" < TO ≤ 14'-0" FOR APPLICABLE RISK CATEGORY WIND SPEEDS

1A

SCALE: NTS

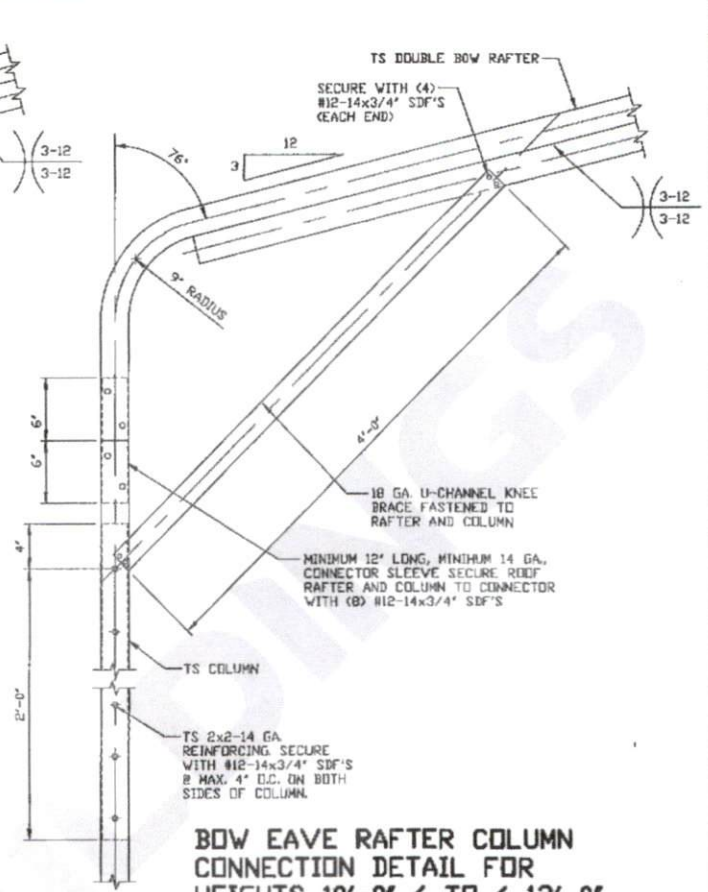

BOW EAVE RAFTER COLUMN CONNECTION DETAIL FOR HEIGHTS 10'-0" < TO ≤ 12'-0" HEIGHTS 9'-0" < TO ≤ 10'-0" FOR APPLICABLE RISK CATEGORY WIND SPEEDS

1B

SCALE: NTS

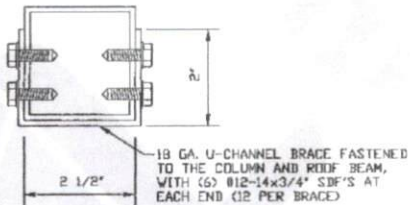

BRACE SECTION

SCALE: NTS

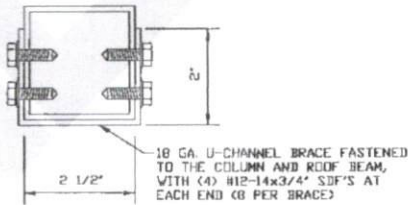

BRACE SECTION

SCALE: NTS

MOORE AND ASSOCIATES ENGINEERING AND CONSULTING, INC.

DRAWN BY: LT

CHECKED BY: PDH

PROJECT MGR: VSM

CLIENT: TOL

TOL BUILDINGS, INC.
P.O. BOX 542
TOAST, NC 27049
30'-0" x 20'-0" ENCLOSED STRUCTURE

DATE: 3-21-22

SHT. 8D

SCALE: NTS

DWG. NO. SK-3

JOB NO. 19164S/22020S

REV: 1

THIS DOCUMENT IS THE PROPERTY OF MOORE AND ASSOCIATES ENGINEERING AND CONSULTING. THE UNAUTHORIZED REPRODUCTION, COPYING, OR OTHERWISE USE OF THIS DOCUMENT IS STRICTLY PROHIBITED AND ANY INFRINGEMENT THEREUPON MAY BE SUBJECT TO LEGAL ACTION.

60 PSF < SL ≤ 70 PSF
EXPOSURE C

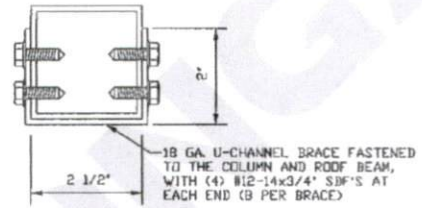
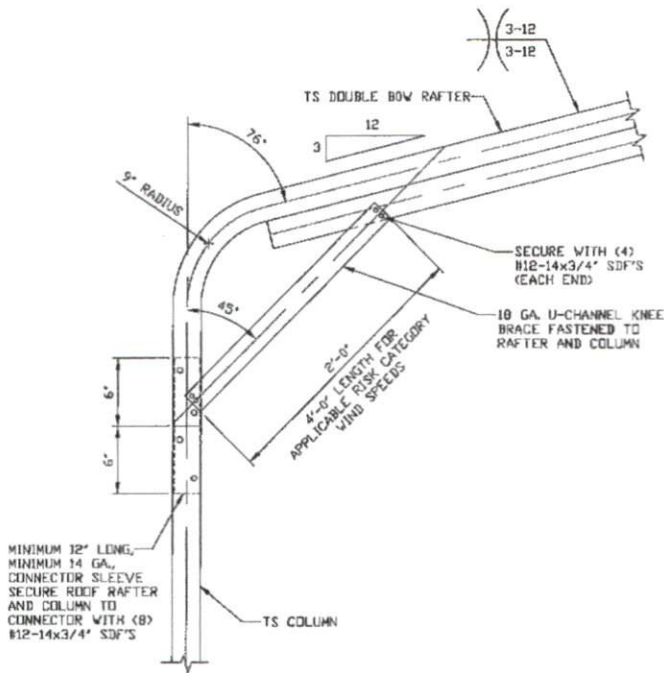

BRACE SECTION
SCALE: NTS

BOW EAVE RAFTER COLUMN CONNECTION DETAIL FOR HEIGHTS ≤ 10'-0" HEIGHTS ≤ 9'-0" FOR APPLICABLE RISK CATEGORY WIND SPEEDS

1C

SCALE: NTS

MOORE AND ASSOCIATES ENGINEERING AND CONSULTING, INC.

DRAWN BY: LT

CHECKED BY: PDH

PROJECT MGR: WSH

CLIENT: TOL

TOL BUILDINGS, INC.
P.O. BOX 542
TOAST, NC 27049
30'-0" x 20'-0" ENCLOSED STRUCTURE

DATE: 3-21-22

SCALE: NTS

SHT. 0E

DWG. NO. SK-3

JOB NO. 19164S/22020S

REV. 1

THIS DOCUMENT IS THE PROPERTY OF MOORE AND ASSOCIATES ENGINEERING AND CONSULTING. THE UNAUTHORIZED REPRODUCTION, COPYING, OR OTHERWISE USE OF THIS DOCUMENT IS STRICTLY PROHIBITED AND ANY INFRINGEMENT THEREUPON MAY BE SUBJECT TO LEGAL ACTION.

SL ≤ 60 PSF
EXPOSURE B/C

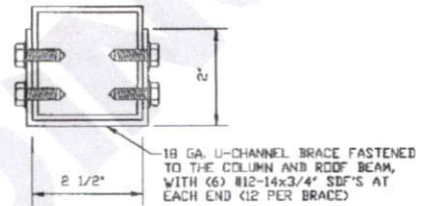
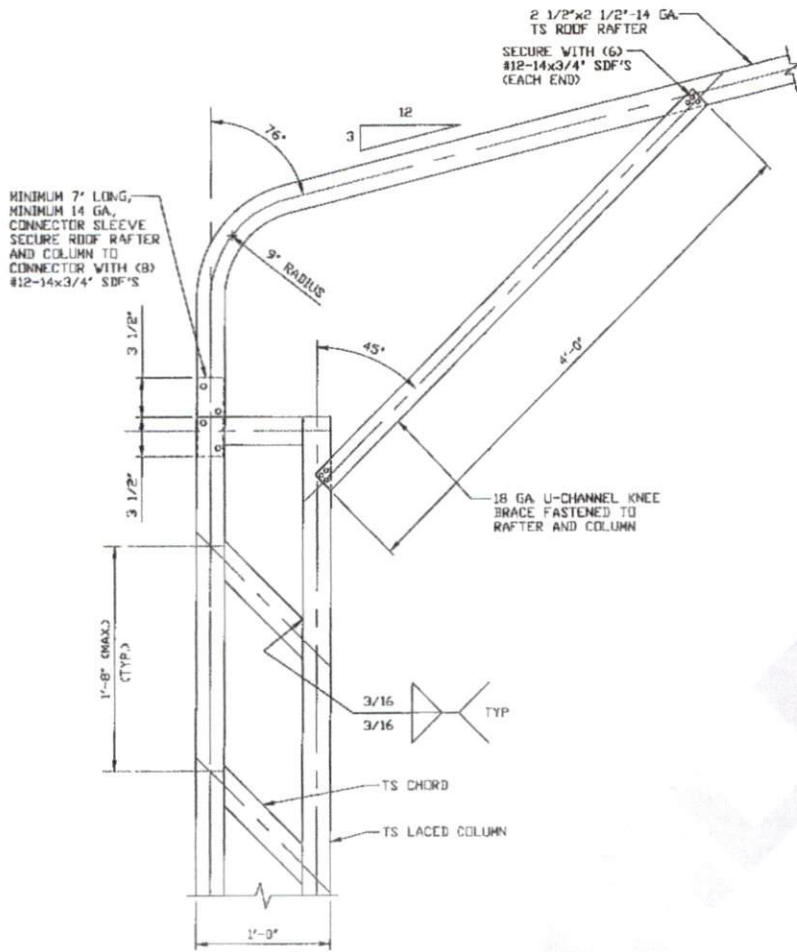

BRACE SECTION
SCALE: NTS

BOW EAVE RAFTER COLUMN CONNECTION DETAIL
FOR HEIGHTS 16'-0" < TO ≤ 20'-0"
HEIGHTS 15'-0" < TO ≤ 20'-0"
FOR APPLICABLE RISK CATEGORY WIND SPEEDS

1

SCALE: NTS

MOORE AND ASSOCIATES
ENGINEERING AND CONSULTING, INC.

DRAWN BY: LT

CHECKED BY: PDH

PROJECT MGR: WSH

CLIENT: TOL

TOL BUILDINGS, INC.
P.O. BOX 542
TOAST, NC 27049
30'-0"x20'-0" ENCLOSED STRUCTURE

DATE: 3-21-22

SHT. 8F

SCALE: NTS

DWG. NO: SK-3

JOB NO:
19164S/22020S

REV: 1

THIS DOCUMENT IS THE PROPERTY OF MOORE AND ASSOCIATES ENGINEERING AND CONSULTING. THE UNAUTHORIZED REPRODUCTION, COPYING, OR OTHERWISE USE OF THIS DOCUMENT IS STRICTLY PROHIBITED AND ANY INFRINGEMENT THEREUPON MAY BE SUBJECT TO LEGAL ACTION.

SL ≤ 60 PSF
EXPOSURE B/C

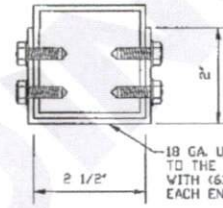
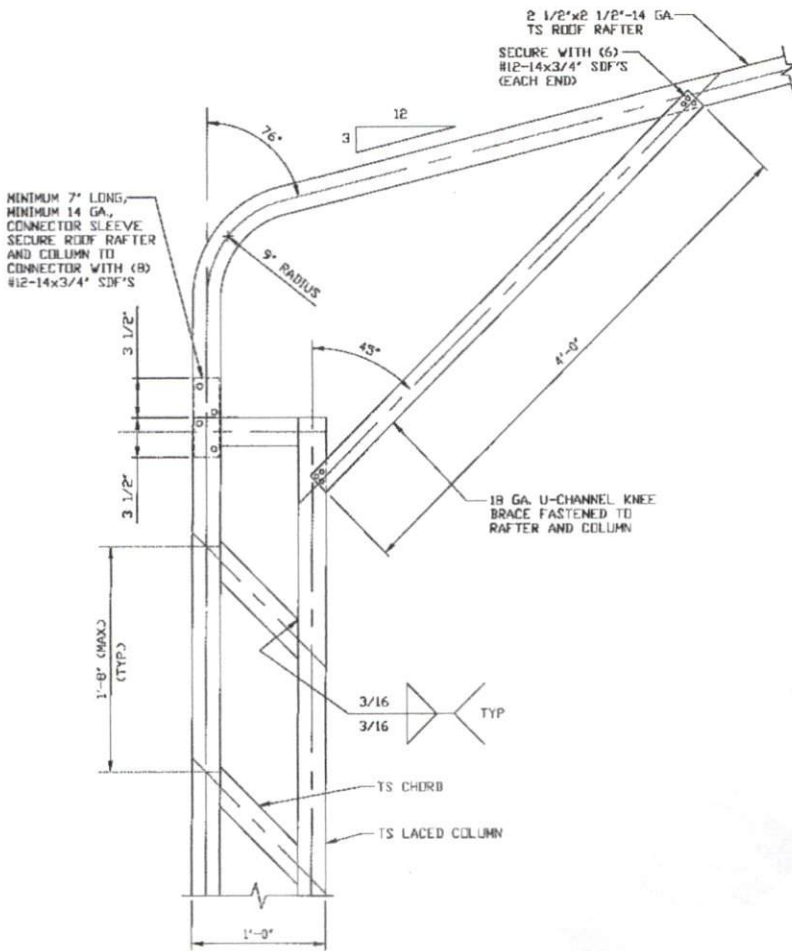

BRACE SECTION
 SCALE: NTS

BOW EAVE RAFTER COLUMN CONNECTION DETAIL
FOR HEIGHTS 16'-0" < TO ≤ 20'-0"
HEIGHTS 15'-0" < TO ≤ 20'-0"
FOR APPLICABLE RISK CATEGORY WIND SPEEDS

1A

SCALE: NTS

MOORE AND ASSOCIATES
ENGINEERING AND CONSULTING, INC.

DRAWN BY: LT

CHECKED BY: PDH

PROJECT MGR: VSM

CLIENT: TOL

TOL BUILDINGS, INC.
 P.O. BOX 542
 TOAST, NC 27049
 30'-0" x 20'-0" ENCLOSED STRUCTURE

DATE: 3-21-22

SHT. 8G

SCALE: NTS

DWG. NO: SK-3

JOB NO:
19164S/22020S

REV: 1

THIS DOCUMENT IS THE PROPERTY OF MOORE AND ASSOCIATES ENGINEERING AND CONSULTING. THE UNAUTHORIZED REPRODUCTION, COPYING, OR OTHERWISE USE OF THIS DOCUMENT IS STRICTLY PROHIBITED AND ANY INFRINGEMENT THEREUPON MAY BE SUBJECT TO LEGAL ACTION.

SL ≤ 60 PSF
EXPOSURE B/C

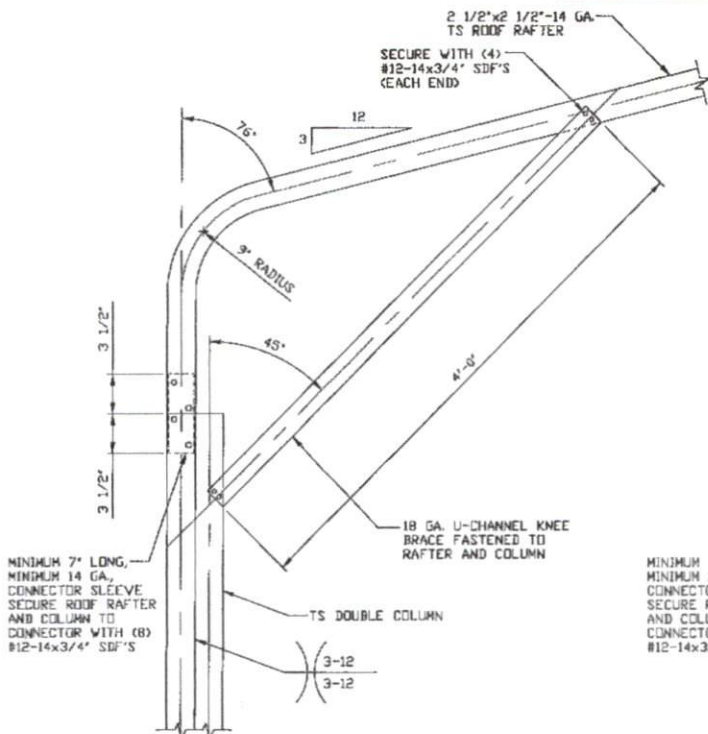

BOW EAVE RAFTER COLUMN CONNECTION DETAIL FOR HEIGHTS 12'-0" < TO ≤ 16'-0" HEIGHTS 11'-0" < TO ≤ 15'-0" FOR APPLICABLE RISK CATEGORY WIND SPEEDS

1B
SCALE: NTS

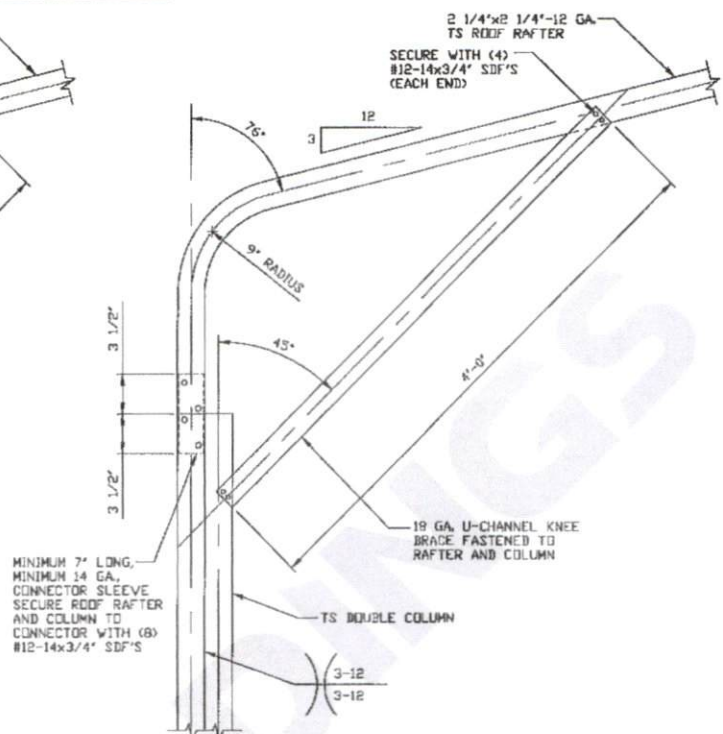

BOW EAVE RAFTER COLUMN CONNECTION DETAIL FOR HEIGHTS 12'-0" < TO ≤ 16'-0" HEIGHTS 11'-0" < TO ≤ 15'-0" FOR APPLICABLE RISK CATEGORY WIND SPEEDS

1C
SCALE: NTS

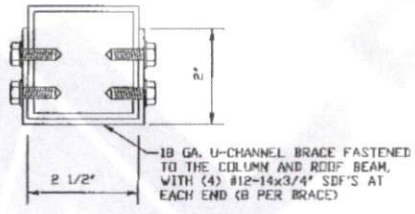

BRACE SECTION
SCALE: NTS

MOORE AND ASSOCIATES ENGINEERING AND CONSULTING, INC.

DRAWN BY: LT
CHECKED BY: PDH

TOL BUILDINGS, INC.
P.O. BOX 542
TOAST, NC 27049
30'-0" x 20'-0" ENCLOSED STRUCTURE

THIS DOCUMENT IS THE PROPERTY OF MOORE AND ASSOCIATES ENGINEERING AND CONSULTING. THE UNAUTHORIZED REPRODUCTION, COPYING, OR OTHERWISE USE OF THIS DOCUMENT IS STRICTLY PROHIBITED AND ANY INFRINGEMENT THEREUPON MAY BE SUBJECT TO LEGAL ACTION.

PROJECT MGR: WSM
CLIENT: TOL

DATE: 3-21-22
SHT. 8H

SCALE: NTS
DWG. NO: SK-3

JOB NO: 19164S/22020S
REV: 1

**SL ≤ 60 PSF
EXPOSURE B/C**

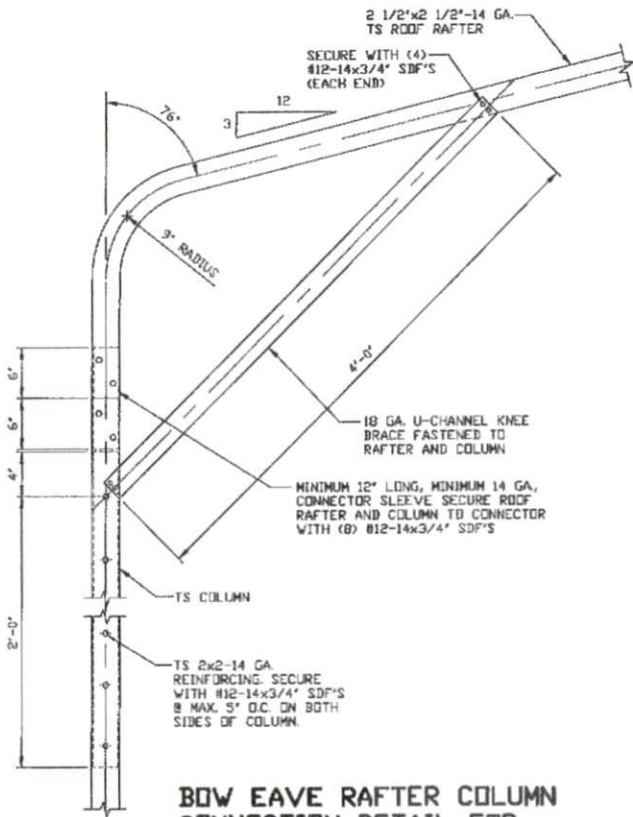

**BOW EAVE RAFTER COLUMN
CONNECTION DETAIL FOR
HEIGHTS 11'-0" < TO ≤ 12'-0"
HEIGHTS 9'-0" < TO ≤ 11'-0"
FOR APPLICABLE RISK
CATEGORY WIND SPEEDS**

1D

SCALE: NTS

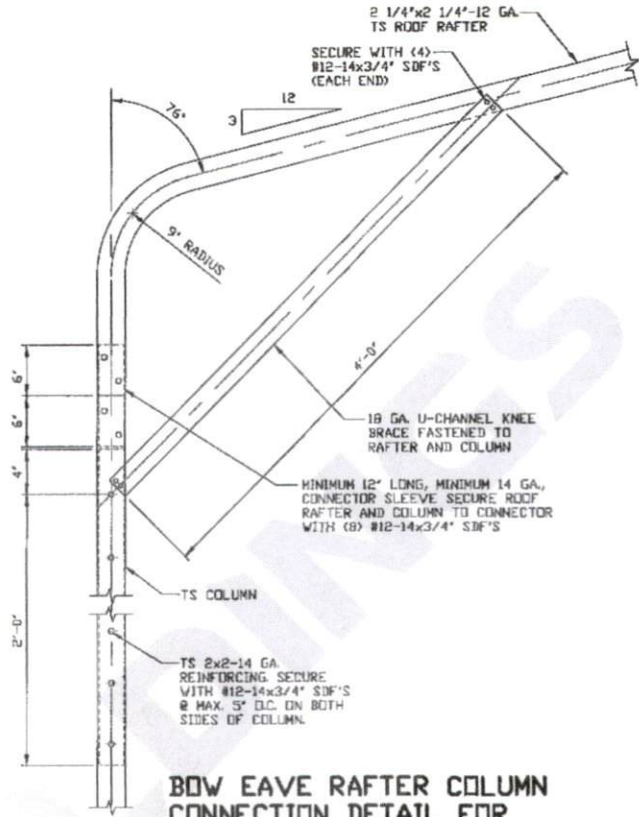

**BOW EAVE RAFTER COLUMN
CONNECTION DETAIL FOR
HEIGHTS 11'-0" < TO ≤ 12'-0"
HEIGHTS 9'-0" < TO ≤ 11'-0"
FOR APPLICABLE RISK
CATEGORY WIND SPEEDS**

1E

SCALE: NTS

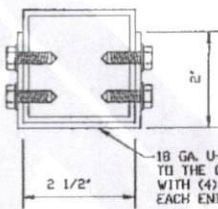

BRACE SECTION

SCALE: NTS

**MOORE AND ASSOCIATES
ENGINEERING AND CONSULTING, INC.**

DRAWN BY: LT

CHECKED BY: PDH

PROJECT MGR: VSM

CLIENT: TOL

TOL BUILDINGS, INC.
P.O. BOX 542
TOAST, NC 27049
30'-0" x 20'-0" ENCLOSED STRUCTURE

DATE: 3-21-22

SHT. 8J

SCALE: NTS

DWG. NO. SK-3

JOB NO.
19164S/22020S

REV. 1

THIS DOCUMENT IS THE PROPERTY OF MOORE AND ASSOCIATES ENGINEERING AND CONSULTING. THE UNAUTHORIZED REPRODUCTION, COPYING, OR OTHERWISE USE OF THIS DOCUMENT IS STRICTLY PROHIBITED AND ANY INFRINGEMENT THEREUPON MAY BE SUBJECT TO LEGAL ACTION.

**SL ≤ 60 PSF
EXPOSURE B/C**

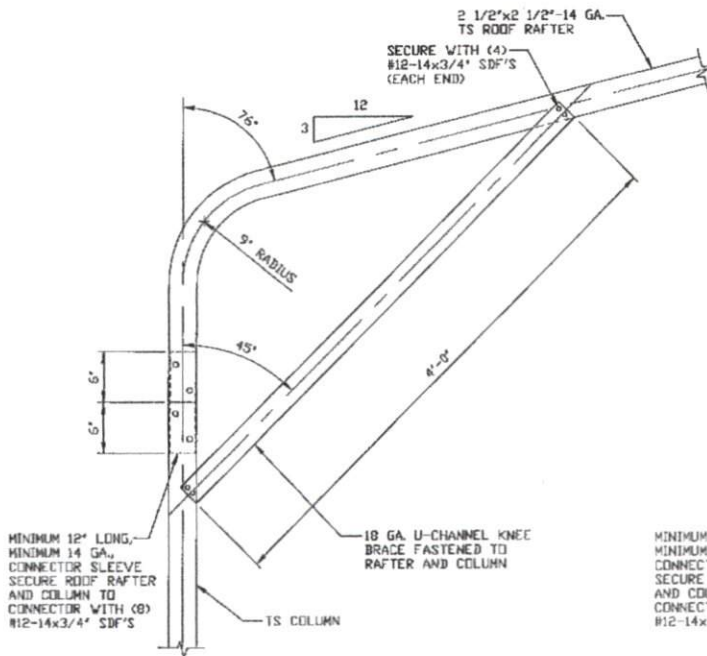

1F
**BOW EAVE RAFTER COLUMN
 CONNECTION DETAIL FOR
 HEIGHTS ≤ 11'-0"
 HEIGHTS ≤ 9'-0"
 FOR APPLICABLE RISK
 CATEGORY WIND SPEEDS**

SCALE: NTS

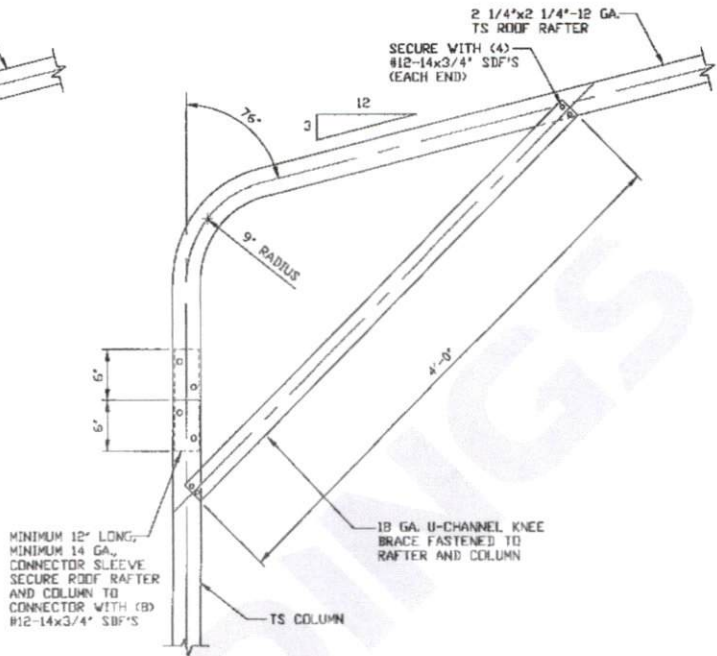

1G
**BOW EAVE RAFTER COLUMN
 CONNECTION DETAIL FOR
 HEIGHTS ≤ 11'-0"
 HEIGHTS ≤ 9'-0"
 FOR APPLICABLE RISK
 CATEGORY WIND SPEEDS**

SCALE: NTS

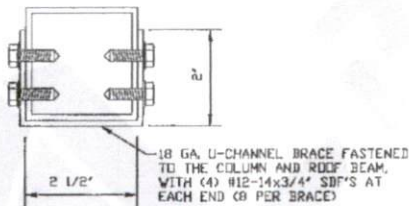

BRACE SECTION

SCALE: NTS

**MOORE AND ASSOCIATES
 ENGINEERING AND CONSULTING, INC.**

DRAWN BY: LT

CHECKED BY: PMH

PROJECT MGR: VSH

CLIENT: TOL

**TOL BUILDINGS, INC.
 P.O. BOX 542
 TOAST, NC 27049
 30'-0" x 20'-0" ENCLOSED STRUCTURE**

DATE: 3-21-22

SCALE: NTS

SHT. BK

DWG. NO: SK-3

**JOB NO:
 19164S/22020S**

REV: 1

THIS DOCUMENT IS THE PROPERTY OF MOORE AND ASSOCIATES ENGINEERING AND CONSULTING. THE UNAUTHORIZED REPRODUCTION, COPYING, OR OTHERWISE USE OF THIS DOCUMENT IS STRICTLY PROHIBITED AND ANY INFRINGEMENT THEREUPON MAY BE SUBJECT TO LEGAL ACTION.

**SL ≤ 30 PSF
EXPOSURE B/C**

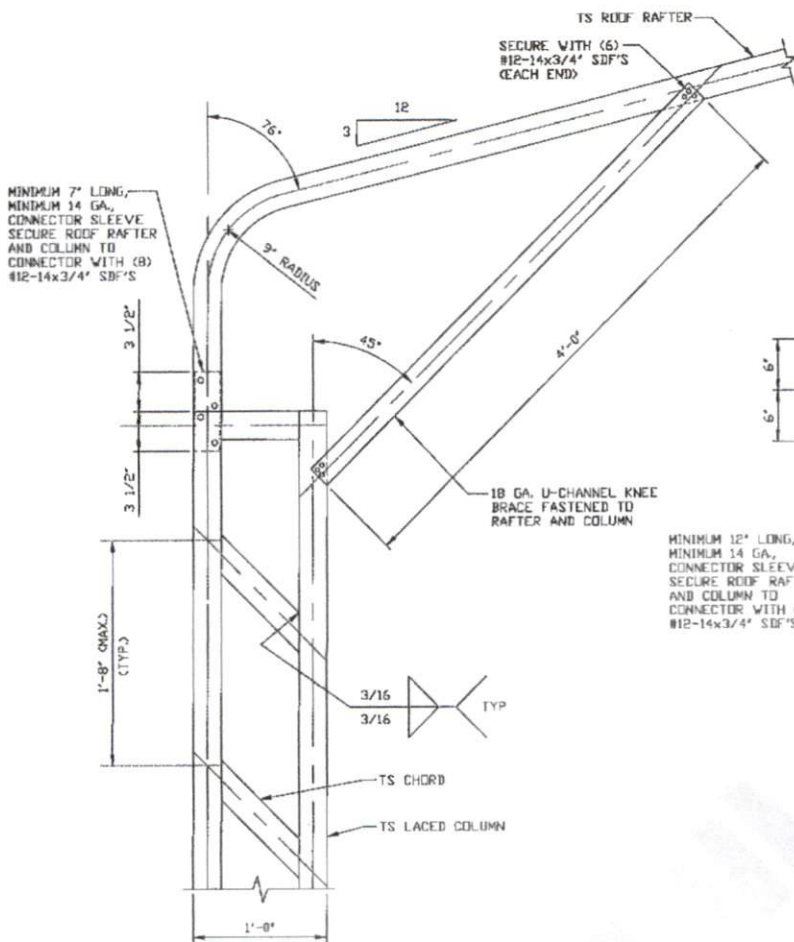

**BOX EAVE RAFTER COLUMN
CONNECTION DETAIL FOR
HEIGHTS 12'-0" < TO ≤ 16'-0"
HEIGHTS 15'-0" < TO ≤ 20'-0"
FOR APPLICABLE RISK
CATEGORY WIND SPEEDS**

1
SCALE: NTS

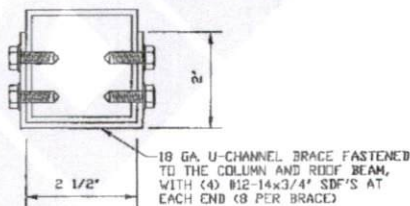

BRACE SECTION
SCALE: NTS

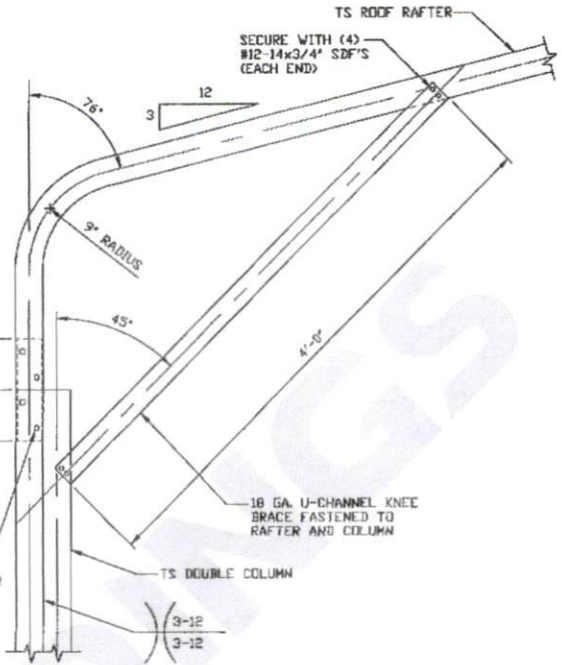

**BOX EAVE RAFTER COLUMN
CONNECTION DETAIL FOR
HEIGHTS 12'-0" < TO ≤ 16'-0"
HEIGHTS 11'-0" < TO ≤ 15'-0"
FOR APPLICABLE RISK
CATEGORY WIND SPEEDS**

1A
SCALE: NTS

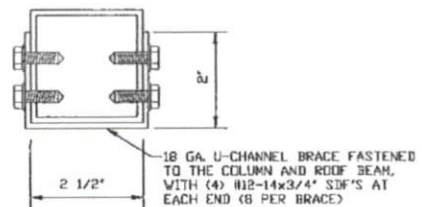

BRACE SECTION
SCALE: NTS

**MOORE AND ASSOCIATES
ENGINEERING AND CONSULTING, INC.**

DRAWN BY: LT
CHECKED BY: PDH

TOL BUILDINGS, INC.
P.O. BOX 542
TOAST, NC 27049
30'-0" x 20'-0" ENCLOSED STRUCTURE

THIS DOCUMENT IS THE PROPERTY OF MOORE AND ASSOCIATES ENGINEERING AND CONSULTING. THE UNAUTHORIZED REPRODUCTION, COPYING, OR OTHERWISE USE OF THIS DOCUMENT IS STRICTLY PROHIBITED AND ANY INFRINGEMENT THEREUPON MAY BE SUBJECT TO LEGAL ACTION.

PROJECT MGR: WSH
CLIENT: TOL

DATE: 3-21-22
SHT. 8L

SCALE: NTS
DWG. NO: SK-3

JOB NO: 19164S/22020S
REV: 1

SL ≤ 30 PSF
EXPOSURE B/C

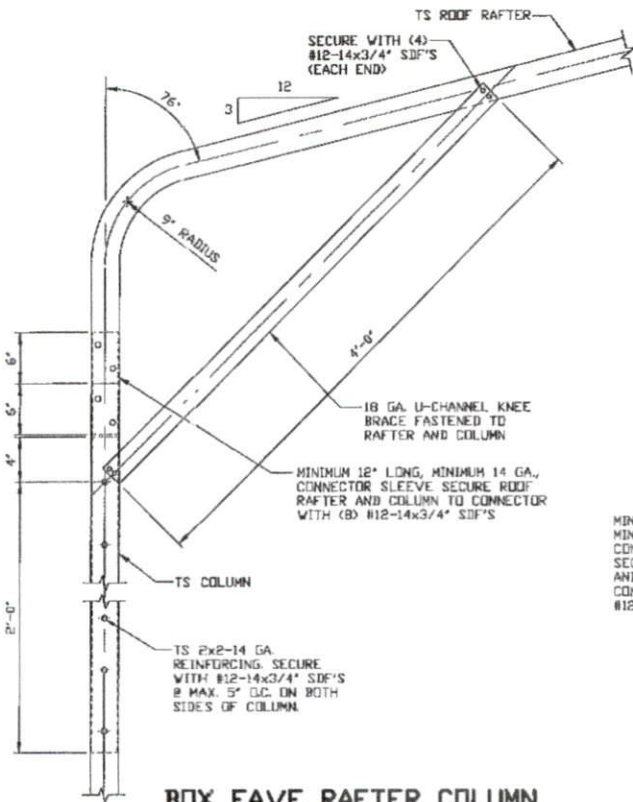

BOX EAVE RAFTER COLUMN CONNECTION DETAIL FOR HEIGHTS 11'-0" < TO ≤ 12'-0" HEIGHTS 9'-0" < TO ≤ 11'-0" FOR APPLICABLE RISK CATEGORY WIND SPEEDS

1B

SCALE: NTS

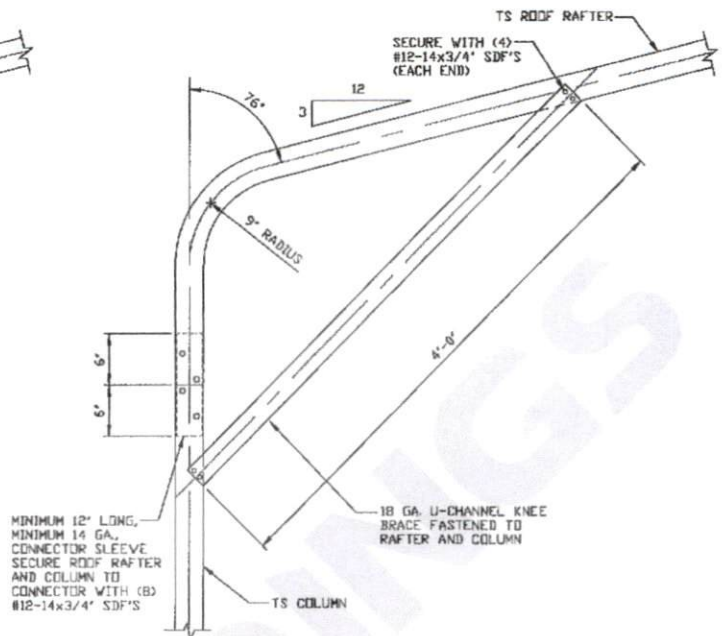

BOX EAVE RAFTER COLUMN CONNECTION DETAIL FOR HEIGHTS ≤ 11'-0" HEIGHTS ≤ 9'-0" FOR APPLICABLE RISK CATEGORY WIND SPEEDS

1C

SCALE: NTS

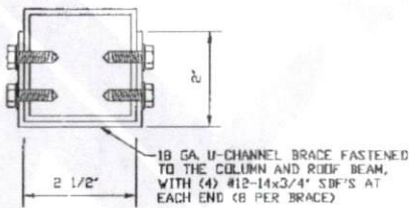

BRACE SECTION

SCALE: NTS

MOORE AND ASSOCIATES ENGINEERING AND CONSULTING, INC.

DRAWN BY: LT

CHECKED BY: PDH

PROJECT MGR: VSM

CLIENT: TOL

TOL BUILDINGS, INC.
P.O. BOX 542
TOAST, NC 27049
30'-0" x 20'-0" ENCLOSED STRUCTURE

DATE: 3-21-22

SHT. 8M

SCALE: NTS

DWG. NO. SK-3

JOB NO. 19164S/22020S

REV. 1

THIS DOCUMENT IS THE PROPERTY OF MOORE AND ASSOCIATES ENGINEERING AND CONSULTING. THE UNAUTHORIZED REPRODUCTION, COPYING, OR OTHERWISE USE OF THIS DOCUMENT IS STRICTLY PROHIBITED AND ANY INFRINGEMENT THEREUPON MAY BE SUBJECT TO LEGAL ACTION.

BASE RAIL ANCHORAGE OPTIONS WITH ATTACHED LEAN-TO

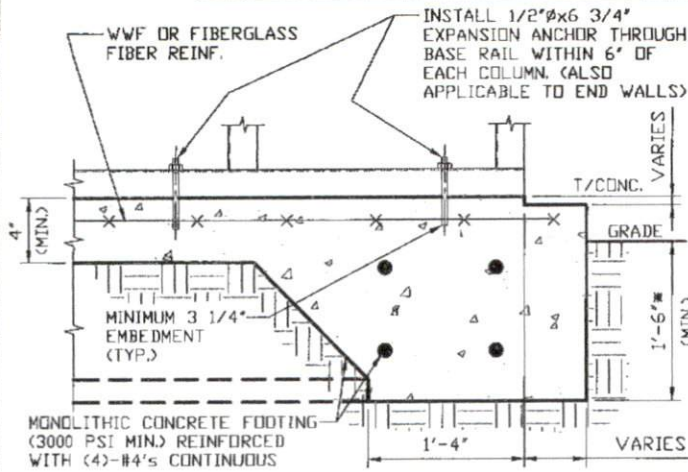

2

CONCRETE MONOLITHIC SLAB BASE RAIL ANCHORAGE

SCALE: NTS
(MINIMUM ANCHOR EDGE DISTANCE IS 4")
* COORDINATE WITH LOCAL BUILDING CODE
AND/OR DRD. REGARDING REQUIRED FOOTING DEPTH.

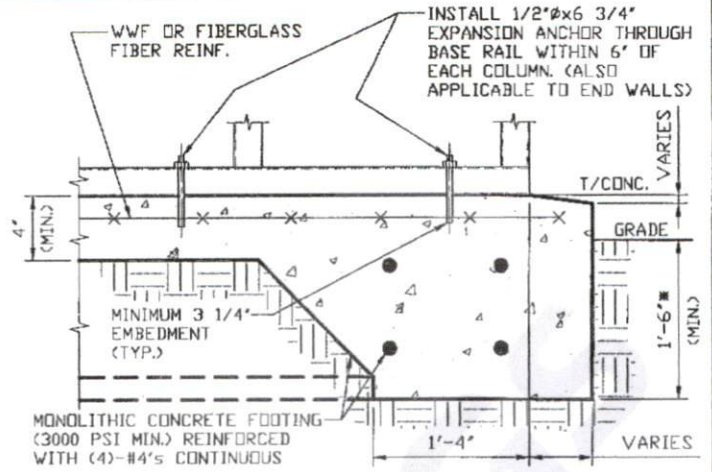

2A

CONCRETE MONOLITHIC SLAB BASE RAIL ANCHORAGE

SCALE: NTS
(MINIMUM ANCHOR EDGE DISTANCE IS 4")
* COORDINATE WITH LOCAL BUILDING CODE
AND/OR DRD. REGARDING REQUIRED FOOTING DEPTH.

GENERAL NOTES

NOTE: CONCRETE MONOLITHIC SLAB DESIGN BASED ON
MINIMUM SOIL BEARING CAPACITY OF 1,500 PSF.

CONCRETE:

CONCRETE SHALL HAVE A MINIMUM SPECIFIED COMPRESSIVE
STRENGTH OF 3,000 PSI AT 28 DAYS.

COVER OVER REINFORCING STEEL:

FOR FOUNDATIONS, MINIMUM CONCRETE COVER OVER REINFORCING
BARS SHALL BE PER ACI-318:
3" IN FOUNDATIONS WHERE THE CONCRETE IS CAST AGAINST AND
PERMANENTLY IN CONTACT WITH THE EARTH OR EXPOSED TO THE
EARTH OR WEATHER, AND 1 1/2" ELSEWHERE.

REINFORCING STEEL:

THE TURNDOWN REINFORCING STEEL SHALL BE ASTM A615 GRADE
60. THE SLAB REINFORCEMENT SHALL BE WELDED WIRE FABRIC
MEETING ASTM A185 OR FIBERGLASS FIBER REINFORCEMENT.

REINFORCEMENT MAY BE BENT IN THE SHOP OR THE FIELD PROVIDED:

1. REINFORCEMENT IS BENT COLD.
2. THE DIAMETER OF THE BEND, MEASURED ON THE INSIDE OF THE
BAR, IS NOT LESS THAN SIX-BAR DIAMETERS.
3. REINFORCEMENT PARTIALLY EMBEDDED IN CONCRETE SHALL NOT
BE FIELD BENT.

HELIX ANCHOR NOTES:

1. FOR VERY DENSE AND/OR CEMENTED SANDS, COARSE GRAVEL
AND COBBLES, CALICHE, PRELOADED SILTS AND CLAYS, USE
MINIMUM (2) 4' HELICES WITH MINIMUM 30" EMBEDMENT OR
SINGLE 6" HELIX WITH MINIMUM 50" EMBEDMENT.
2. FOR CORAL USE MINIMUM (2) 4' HELICES WITH MINIMUM
30" EMBEDMENT OR SINGLE 6" HELIX WITH MINIMUM
50" EMBEDMENT.
3. FOR MEDIUM DENSE COARSE SANDS, SANDY GRAVELS, VERY
STIFF SILTS, AND CLAYS USE MINIMUM (2) 4' HELICES WITH
MINIMUM 30 INCH EMBEDMENT OR SINGLE 6" HELIX WITH MINIMUM
50" EMBEDMENT.
4. FOR LOOSE TO MEDIUM DENSE SANDS, FIRM TO STIFF CLAYS AND
SILTS ALLUVIAL FILL, USE MINIMUM (2) 6" HELICES WITH MINIMUM
50" EMBEDMENT.
5. FOR VERY LOOSE TO MEDIUM DENSE SANDS, FIRM TO STIFFER
CLAYS AND SILTS, ALLUVIAL FILL, USE MINIMUM (2) 8" HELICES
WITH MINIMUM 60" EMBEDMENT.

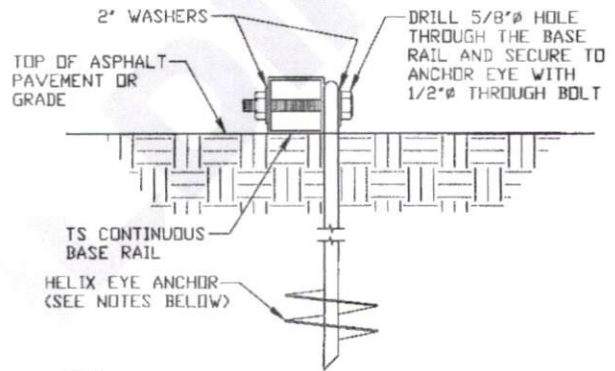

2B

GROUND BASE HELIX ANCHORAGE

SCALE: NTS (CAN BE USED FOR ASPHALT)
* COORDINATE WITH LOCAL CODES/DRD.
REGARDING MINIMUM FROST DEPTH REQ.
NOTE: TWO EXPANSION ANCHORS ARE REQ'D.
AT EVERY COLUMN WHEN LEAN-TO ARE
ATTACHED TO STRUCTURE.

**MOORE AND ASSOCIATES
ENGINEERING AND CONSULTING, INC.**

DRAWN BY: LT

CHECKED BY: PDH

PROJECT MGR: VSM

CLIENT: TOL

TOL BUILDINGS, INC.
P.O. BOX 542
TOAST, NC 27049
30'-0" x 20'-0" ENCLOSED STRUCTURE

DATE: 9-21-22

SHT. 9

SCALE: NTS

DWG. NO: SK-3

JOB NO:
19164S/22020S

REV: 1

THIS DOCUMENT IS THE PROPERTY OF MOORE AND ASSOCIATES ENGINEERING AND
CONSULTING. THE UNAUTHORIZED REPRODUCTION, COPYING, OR OTHERWISE USE OF
THIS DOCUMENT IS STRICTLY PROHIBITED AND ANY INFRINGEMENT THEREUPON MAY
BE SUBJECT TO LEGAL ACTION.

BASE RAIL ANCHORAGE OPTIONS WITHOUT ATTACHED LEAN-TO

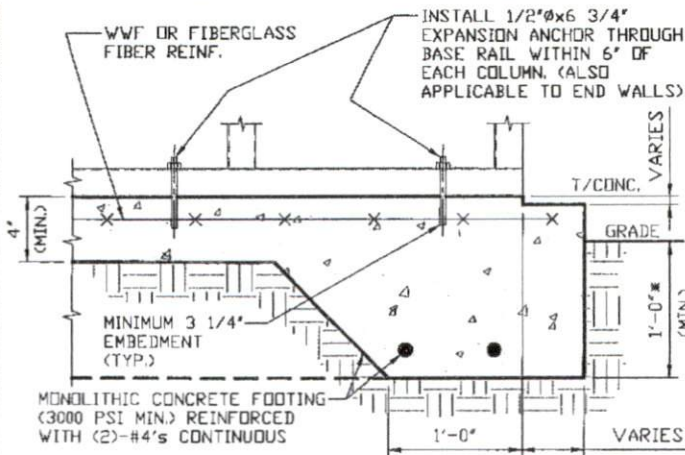

2

CONCRETE MONOLITHIC SLAB BASE RAIL ANCHORAGE

SCALE: NTS
(MINIMUM ANCHOR EDGE DISTANCE IS 4")
* COORDINATE WITH LOCAL BUILDING CODE
AND/OR D. REGARDING REQUIRED FOOTING DEPTH.

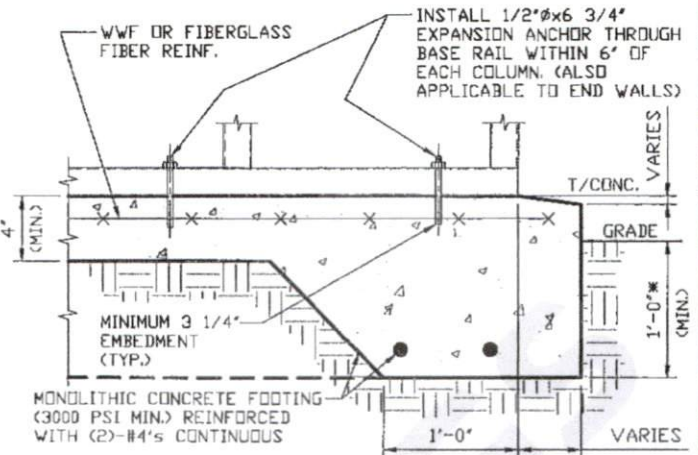

2A

CONCRETE MONOLITHIC SLAB BASE RAIL ANCHORAGE

SCALE: NTS
(MINIMUM ANCHOR EDGE DISTANCE IS 4")
* COORDINATE WITH LOCAL BUILDING CODE
AND/OR D. REGARDING REQUIRED FOOTING DEPTH.

GENERAL NOTES

NOTE: CONCRETE MONOLITHIC SLAB DESIGN BASED ON MINIMUM SOIL BEARING CAPACITY OF 1,500 PSF.

CONCRETE:

CONCRETE SHALL HAVE A MINIMUM SPECIFIED COMPRESSIVE STRENGTH OF 3,000 PSI AT 28 DAYS.

COVER OVER REINFORCING STEEL:

FOR FOUNDATIONS, MINIMUM CONCRETE COVER OVER REINFORCING BARS SHALL BE PER ACI-318;
3" IN FOUNDATIONS WHERE THE CONCRETE IS CAST AGAINST AND PERMANENTLY IN CONTACT WITH THE EARTH OR EXPOSED TO THE EARTH OR WEATHER, AND 1 1/2" ELSEWHERE.

REINFORCING STEEL:

THE TURNDOWN REINFORCING STEEL SHALL BE ASTM A615 GRADE 60. THE SLAB REINFORCEMENT SHALL BE WELDED WIRE FABRIC MEETING ASTM A185 OR FIBERGLASS FIBER REINFORCEMENT.

REINFORCEMENT MAY BE BENT IN THE SHOP OR THE FIELD PROVIDED:

1. REINFORCEMENT IS BENT COLD.
2. THE DIAMETER OF THE BEND, MEASURED ON THE INSIDE OF THE BAR, IS NOT LESS THAN SIX-BAR DIAMETERS.
3. REINFORCEMENT PARTIALLY EMBEDDED IN CONCRETE SHALL NOT BE FIELD BENT.

HELIX ANCHOR NOTES:

1. FOR VERY DENSE AND/OR CEMENTED SANDS, COARSE GRAVEL AND COBBLES, CALICHE, PRELOADED SILTS AND CLAYS, USE MINIMUM (2) 4" HELICES WITH MINIMUM 30" EMBEDMENT OR SINGLE 6" HELIX WITH MINIMUM 50" EMBEDMENT.
2. FOR CORAL USE MINIMUM (2) 4" HELICES WITH MINIMUM 30" EMBEDMENT OR SINGLE 6" HELIX WITH MINIMUM 50" EMBEDMENT.
3. FOR MEDIUM DENSE COARSE SANDS, SANDY GRAVELS, VERY STIFF SILTS, AND CLAYS USE MINIMUM (2) 4" HELICES WITH MINIMUM 30 INCH EMBEDMENT OR SINGLE 6" HELIX WITH MINIMUM 50" EMBEDMENT.
4. FOR LOOSE TO MEDIUM DENSE SANDS, FIRM TO STIFF CLAYS AND SILTS ALLUVIAL FILL, USE MINIMUM (2) 6" HELICES WITH MINIMUM 50" EMBEDMENT.
5. FOR VERY LOSE TO MEDIUM DENSE SANDS, FIRM TO STIFFER CLAYS AND SILTS, ALLUVIAL FILL, USE MINIMUM (2) 8" HELICES WITH MINIMUM 60" EMBEDMENT.

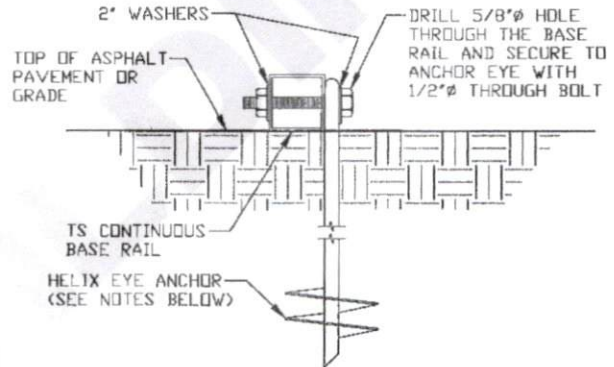

2B

GROUND BASE HELIX ANCHORAGE

SCALE: NTS (CAN BE USED FOR ASPHALT)
* COORDINATE WITH LOCAL CODES/ORD.
REGARDING MINIMUM FROST DEPTH REQ.

MOORE AND ASSOCIATES
ENGINEERING AND CONSULTING, INC.

DRAWN BY: LT

CHECKED BY: PDH

PROJECT MGR: WSM

CLIENT: TOL

TOL BUILDINGS, INC.
P.O. BOX 542
TOAST, NC 27049
30'-0" x 20'-0" ENCLOSED STRUCTURE

DATE: 3-21-22

SHT. 9A

SCALE: NTS

DWG. NO: SK-3

JOB NO:
19164S/22020S

REV: 1

THIS DOCUMENT IS THE PROPERTY OF MOORE AND ASSOCIATES ENGINEERING AND CONSULTING. THE UNAUTHORIZED REPRODUCTION, COPYING, OR OTHERWISE USE OF THIS DOCUMENT IS STRICTLY PROHIBITED AND ANY INFRINGEMENT THEREUPON MAY BE SUBJECT TO LEGAL ACTION.

BASE RAIL ANCHORAGE OPTIONS

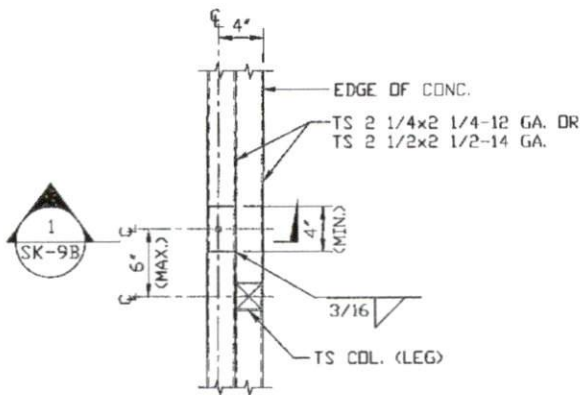

TYPICAL ANCHOR DETAIL WHEN BASE RAIL IS NEAR EDGE OF CONCRETE

SCALE: NTS

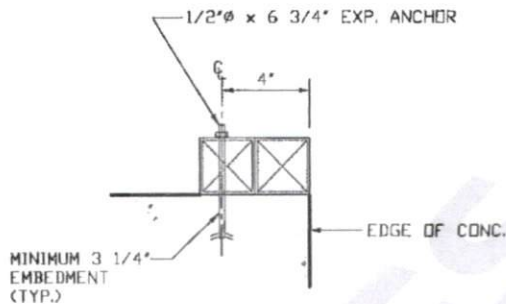

SECTION 1 SK-9B
 SCALE: NTS

**MOORE AND ASSOCIATES
 ENGINEERING AND CONSULTING, INC.**

DRAWN BY: LT

CHECKED BY: PDH

PROJECT MGR: VSM

CLIENT: TDL

TOL BUILDINGS, INC.
 P.O. BOX 542
 TOAST, NC 27049
 30'-0" x 20'-0" ENCLOSED STRUCTURE

DATE: 3-21-22

SHT. 9B

SCALE: NTS

DWG. NO: SK-3

JOB NO:
 19164S/P2020S

REV: 1

THIS DOCUMENT IS THE PROPERTY OF MOORE AND ASSOCIATES ENGINEERING AND CONSULTING. THE UNAUTHORIZED REPRODUCTION, COPYING, OR OTHERWISE USE OF THIS DOCUMENT IS STRICTLY PROHIBITED AND ANY INFRINGEMENT THEREUPON MAY BE SUBJECT TO LEGAL ACTION.

BOX EAVE RAFTER END WALL AND SIDE WALL OPENINGS

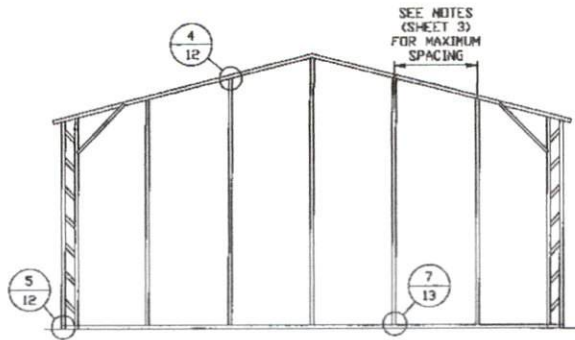

**TYPICAL BOX EAVE RAFTER
END WALL FRAMING SECTION**

SCALE: NTS

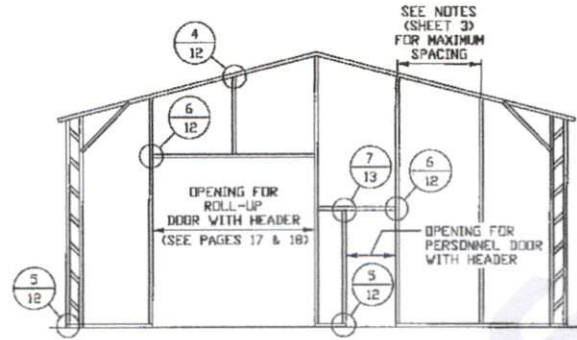

**TYPICAL BOX EAVE RAFTER END
WALL OPENINGS FRAMING SECTION**

SCALE: NTS

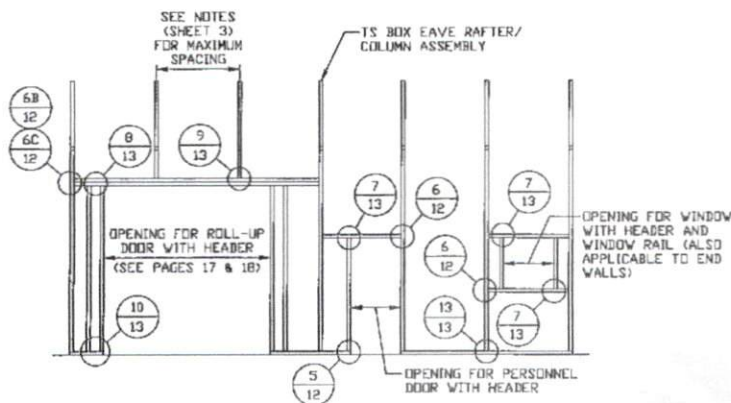

**TYPICAL BOX EAVE RAFTER SIDE
WALL OPENINGS FRAMING SECTION**

SCALE: NTS

**MOORE AND ASSOCIATES
ENGINEERING AND CONSULTING, INC.**

DRAWN BY: LT

CHECKED BY: PDH

PROJECT MGR: WSM

CLIENT: TOL

TOL BUILDINGS, INC.
P.O. BOX 542
TOAST, NC 27049
30'-0" x 20'-0" ENCLOSED STRUCTURE

DATE: 3-21-22

SHT. 10

SCALE: NTS

DWG. NO: SK-3

**JOB NO:
19164S/22020S**

REV: 1

THIS DOCUMENT IS THE PROPERTY OF MOORE AND ASSOCIATES ENGINEERING AND CONSULTING. THE UNAUTHORIZED REPRODUCTION, COPYING, OR OTHERWISE USE OF THIS DOCUMENT IS STRICTLY PROHIBITED AND ANY INFRINGEMENT THEREUPON MAY BE SUBJECT TO LEGAL ACTION.

BOW RAFTER END WALL AND SIDE WALL OPENINGS

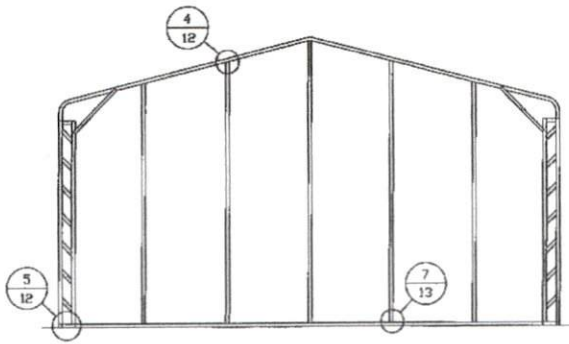

TYPICAL BOW RAFTER END WALL FRAMING SECTION

SCALE: NTS

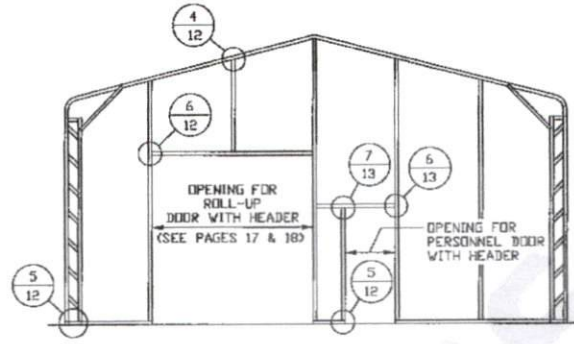

TYPICAL BOW RAFTER END WALL OPENINGS FRAMING SECTION

SCALE: NTS

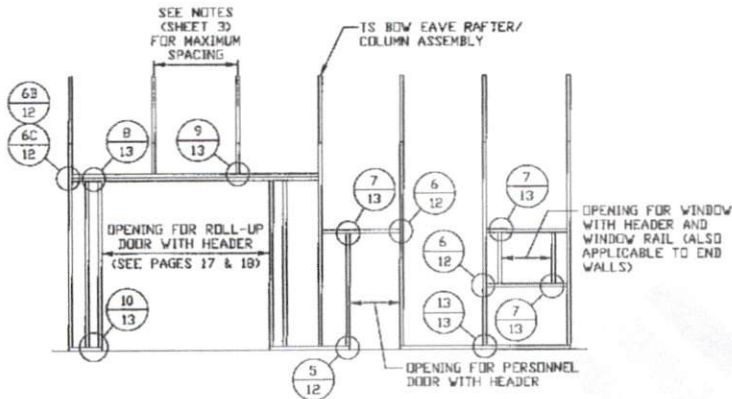

TYPICAL BOW RAFTER SIDE WALL OPENINGS FRAMING SECTION

SCALE: NTS

**MOORE AND ASSOCIATES
ENGINEERING AND CONSULTING, INC.**

DRAWN BY: LT

CHECKED BY: PDH

PROJECT MGR: VSM

CLIENT: TOL

TOL BUILDINGS, INC.
P.O. BOX 542
TOAST, NC 27049
30'-0" x 20'-0" ENCLOSED STRUCTURE

DATE: 3-21-22

SHT. 11

SCALE: NTS

DWG. NO: SK-3

JOB NO: 19164S/22020S

REV: 1

THIS DOCUMENT IS THE PROPERTY OF MOORE AND ASSOCIATES ENGINEERING AND CONSULTING. THE UNAUTHORIZED REPRODUCTION, COPYING, OR OTHERWISE USE OF THIS DOCUMENT IS STRICTLY PROHIBITED AND ANY INFRINGEMENT THEREUPON MAY BE SUBJECT TO LEGAL ACTION.

CONNECTION DETAILS

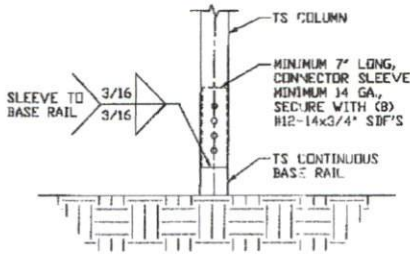

3 COLUMN/BASE RAIL CONNECTION DETAIL

SCALE: NTS

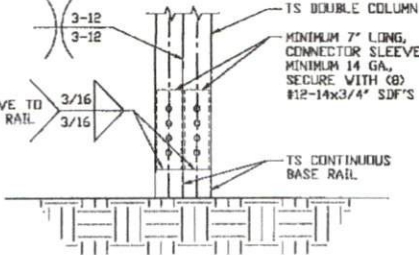

3A DOUBLE COLUMN/BASE RAIL CONNECTION DETAIL

SCALE: NTS

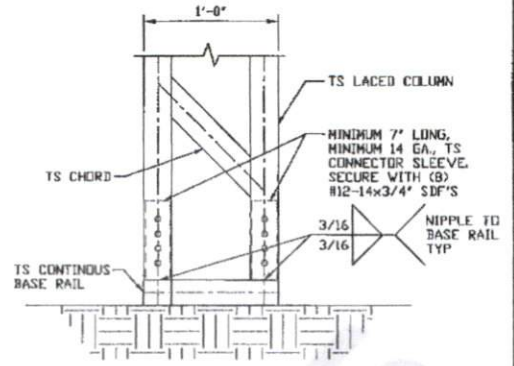

3B LACED COLUMN/BASE RAIL CONNECTION DETAIL

SCALE: NTS

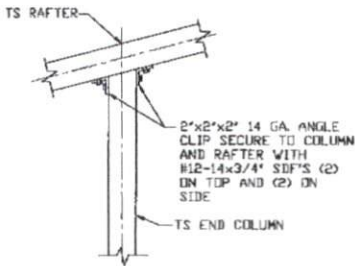

4 END COLUMN/RAFTER CONNECTION DETAIL

SCALE: NTS

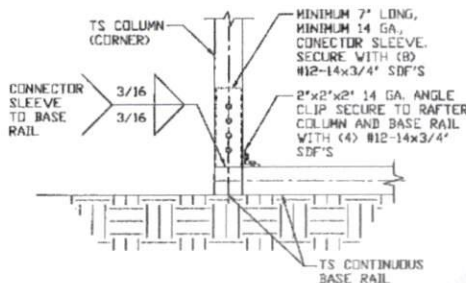

5 END COLUMN/BASE RAIL CONNECTION DETAIL

SCALE: NTS

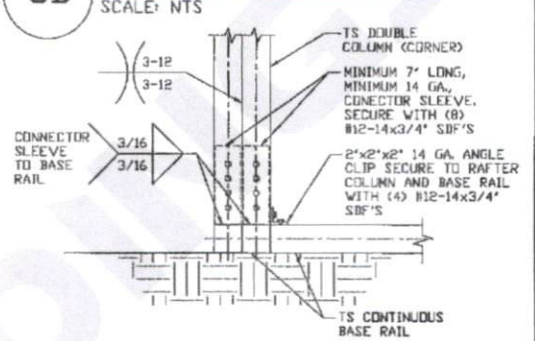

5A END COLUMN/BASE RAIL CONNECTION DETAIL

SCALE: NTS

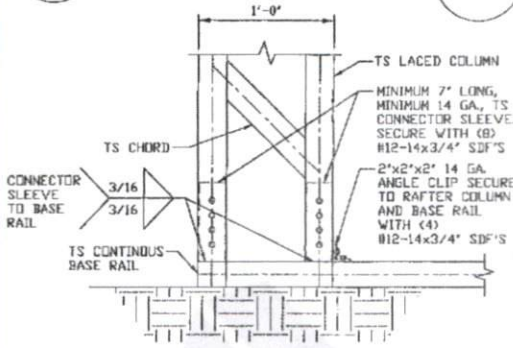

5B END COLUMN/BASE RAIL CONNECTION DETAIL

SCALE: NTS

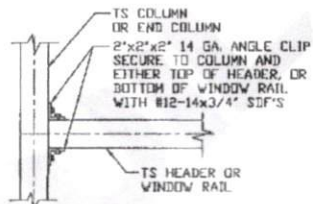

6 COLUMN OR WINDOW RAIL TO POST CONNECTION DETAIL

SCALE: NTS

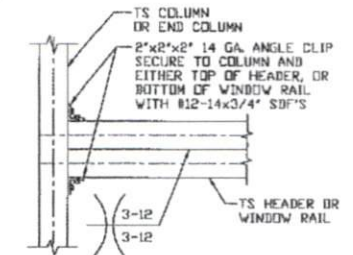

6A DOUBLE HEADER/COLUMN CONNECTION DETAIL

SCALE: NTS

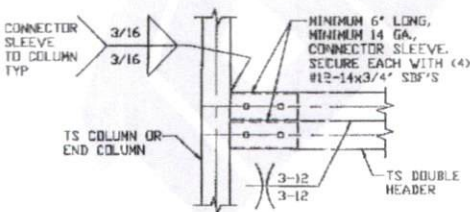

6B SIDE WALL DOUBLE HEADER/COLUMN CONNECTION DETAIL

SCALE: NTS

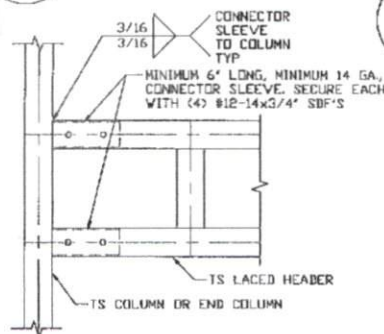

6C SIDE WALL LACED HEADER/COLUMN CONNECTION DETAIL

SCALE: NTS

**MOORE AND ASSOCIATES
ENGINEERING AND CONSULTING, INC.**

DRAWN BY: LT

CHECKED BY: PDH

PROJECT MGR: WSM

CLIENT: TOL

TOL BUILDINGS, INC.
P.O. BOX 542
TOAST, NC 27049
30'-0" x 20'-0" ENCLOSED STRUCTURE

DATE: 3-21-22

SHT. 12

SCALE: NTS

DWG. NO: SK-3

JOB NO:
19164S/22020S

REV: 1

THIS DOCUMENT IS THE PROPERTY OF MOORE AND ASSOCIATES ENGINEERING AND CONSULTING. THE UNAUTHORIZED REPRODUCTION, COPYING, OR OTHERWISE USE OF THIS DOCUMENT IS STRICTLY PROHIBITED AND ANY INFRINGEMENT THEREUPON MAY BE SUBJECT TO LEGAL ACTION.

CONNECTION DETAILS

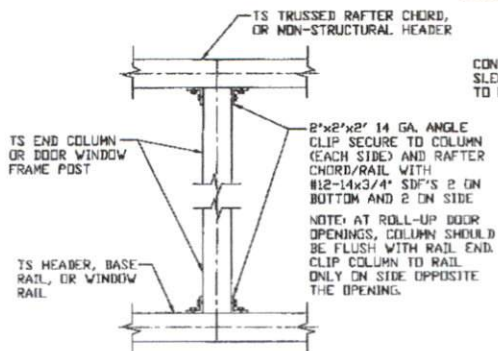

7 COLUMN TO HEADER, BASE RAIL OR WINDOW RAIL CONNECTION DETAIL
SCALE: NTS

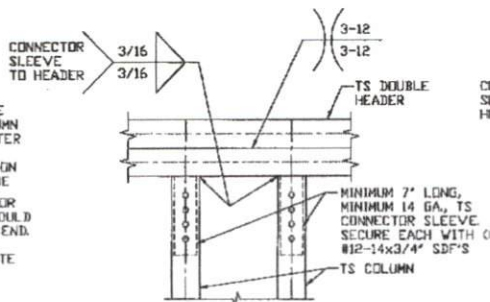

8 DOUBLE HEADER/COLUMN CONNECTION DETAIL
SCALE: NTS

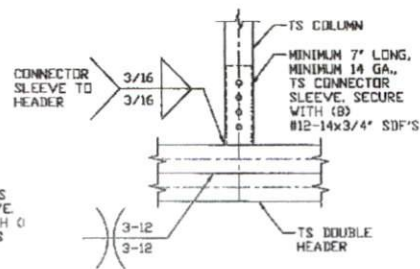

9 COLUMN/DOUBLE HEADER CONNECTION DETAIL
SCALE: NTS

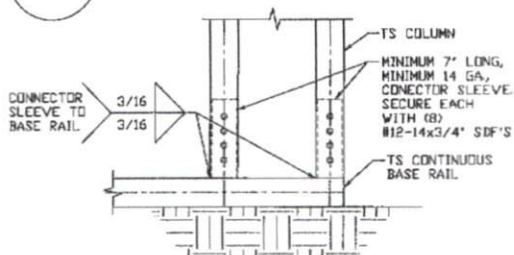

10 COLUMN/BASE RAIL CONNECTION DETAIL
SCALE: NTS

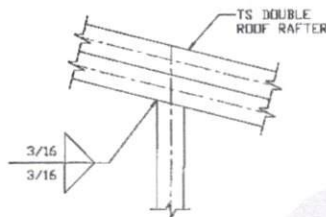

11 RAFTER TO CHORD CONNECTION DETAIL
SCALE: NTS

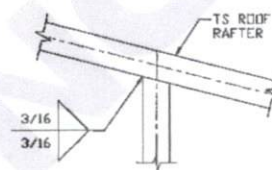

11A RAFTER TO CHORD CONNECTION DETAIL
SCALE: NTS

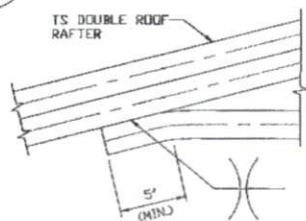

12 COLLAR TIE CONNECTION DETAIL
SCALE: NTS

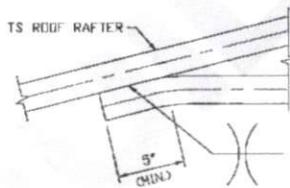

12A COLLAR TIE CONNECTION DETAIL
SCALE: NTS

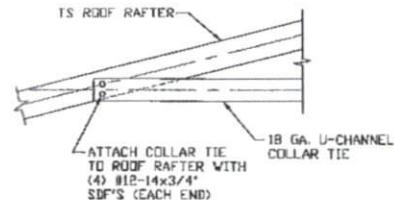

12B COLLAR TIE CONNECTION DETAIL
SCALE: NTS

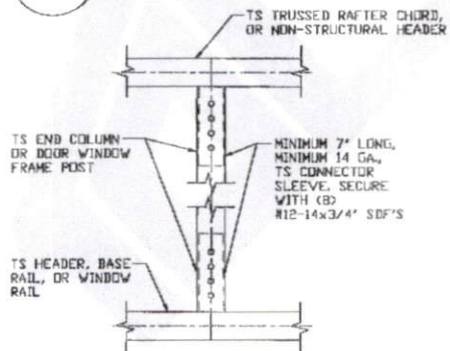

13 COLUMN TO HEADER OR BASE RAIL CONNECTION DETAIL
SCALE: NTS

MOORE AND ASSOCIATES
ENGINEERING AND CONSULTING, INC.

DRAWN BY: LT

CHECKED BY: PDH

PROJECT MGR: WSM

CLIENT: TOL

TOL BUILDINGS, INC.
P.O. BOX 542
TOAST, NC 27049
30'-0" x 20'-0" ENCLOSED STRUCTURE

DATE: 3-21-22

SHT. 13

SCALE: NTS

DWG. NO: SK-3

JOB NO:
19164S/22020S

REV. 1

THIS DOCUMENT IS THE PROPERTY OF MOORE AND ASSOCIATES ENGINEERING AND CONSULTING. THE UNAUTHORIZED REPRODUCTION, COPYING, OR OTHERWISE USE OF THIS DOCUMENT IS STRICTLY PROHIBITED AND ANY INFRINGEMENT THEREUPON MAY BE SUBJECT TO LEGAL ACTION.

BOX EAVE RAFTER LEAN-TO OPTIONS

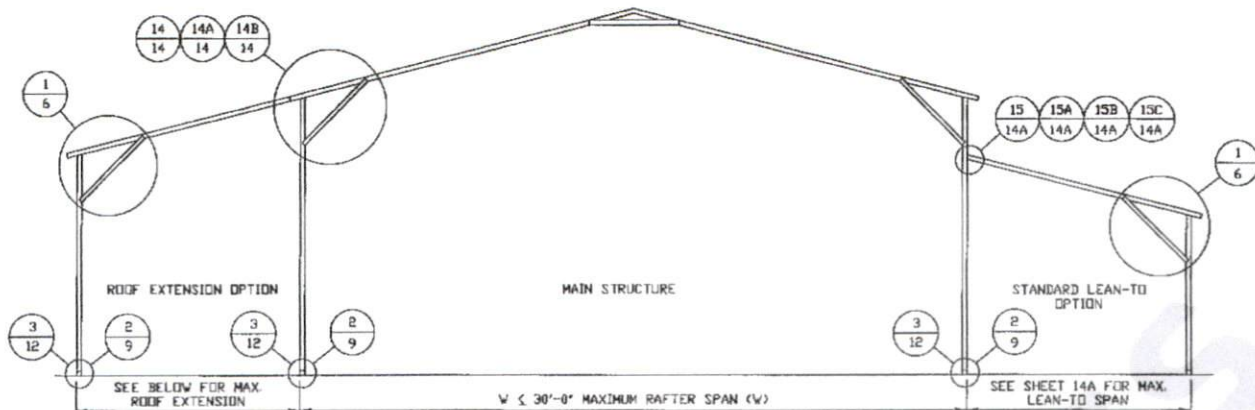

TYPICAL BOX EAVE RAFTER LEAN-TO OPTIONS FRAMING SECTION (BOTH OPTIONS SHOWN)

SCALE: NTS

MAXIMUM WIDTH OF SINGLE MEMBER ROOF EXTENSION AND LEAN-TO IS 10'-0".

MAXIMUM WIDTH OF DOUBLE MEMBER ROOF EXTENSION AND LEAN-TO IS 16'-0".

MAXIMUM WIDTH OF LACED MEMBER ROOF EXTENSION AND LEAN-TO IS 24'-0".

MAIN BUILDING COLUMNS WITH LEAN-TO OR ROOF EXTENSION ATTACHED ARE REQUIRED TO BE LACED COLUMNS FOR

EAVE HEIGHTS 14'-0" < TO ≤ 20'-0".

MAIN BUILDING COLUMNS WITH LEAN-TO OR ROOF EXTENSION ATTACHED ARE REQUIRED TO BE DOUBLE COLUMNS FOR

EAVE HEIGHTS 10'-0" < TO ≤ 16'-0".

MAIN BUILDING COLUMNS WITH LEAN-TO OR ROOF EXTENSION ATTACHED ARE REQUIRED TO BE SINGLE COLUMNS WITH

INSERTS FOR EAVE HEIGHTS 9'-0" < TO ≤ 12'-0".

MAIN BUILDING COLUMNS WITH LEAN-TO OR ROOF EXTENSION ATTACHED ARE REQUIRED TO BE SINGLE COLUMNS FOR

EAVE HEIGHTS ≤ 9'-0".

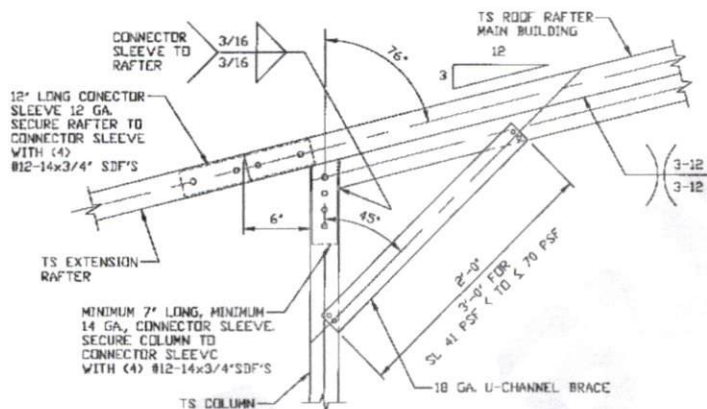

14 SIDE EXTENSION RAFTER/COLUMN DETAIL FOR SPAN ≤ 10'-0"

SCALE: NTS

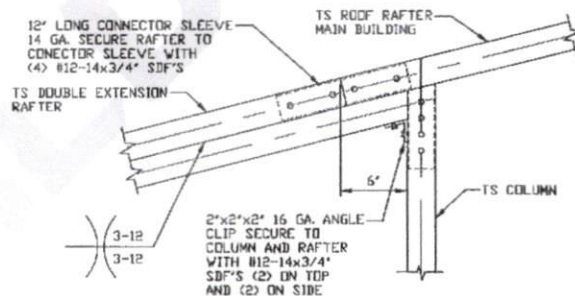

14A SIDE EXTENSION RAFTER/COLUMN DETAIL FOR SPAN 10'-0" < L ≤ 16'-0"

SCALE: NTS

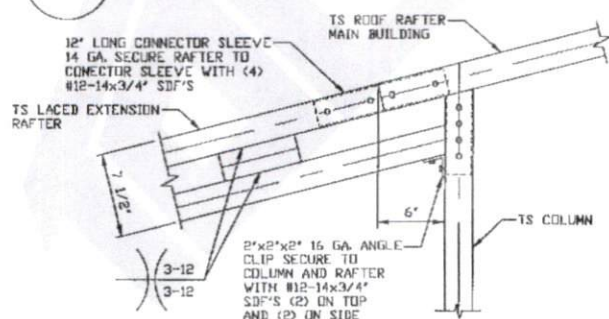

14B SIDE EXTENSION RAFTER/COLUMN DETAIL FOR SPAN 16'-0" < L ≤ 24'-0"

SCALE: NTS

**MOORE AND ASSOCIATES
ENGINEERING AND CONSULTING, INC.**

DRAWN BY: LT

CHECKED BY: PDH

PROJECT MGR: WSM

CLIENT: TOL

TOL BUILDINGS, INC.

P.O. BOX 542

TOAST, NC 27049

30'-0" x 20'-0" ENCLOSED STRUCTURE

DATE: 3-21-22

SHT. 14

SCALE: NTS

DWG. NO. SK-3

JOB NO. 19164S/22020S

REV. 1

THIS DOCUMENT IS THE PROPERTY OF MOORE AND ASSOCIATES ENGINEERING AND CONSULTING. THE UNAUTHORIZED REPRODUCTION, COPYING, OR OTHERWISE USE OF THIS DOCUMENT IS STRICTLY PROHIBITED AND ANY INFRINGEMENT THEREUPON MAY BE SUBJECT TO LEGAL ACTION.

BOX EAVE RAFTER LEAN-TO OPTIONS

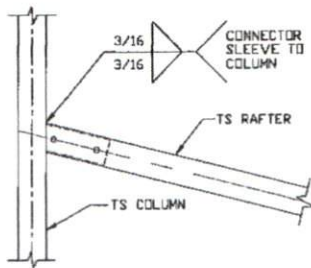

15

**LEAN-TO RAFTER TO RAFTER
COLUMN CONNECTION DETAIL
FOR SPAN $\le 10'-0''$**

SCALE: NTS

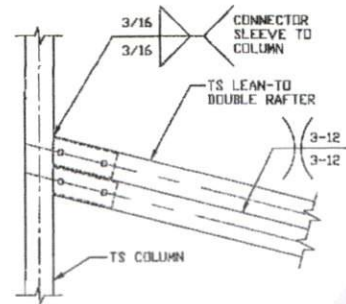

15A

**LEAN-TO RAFTER TO RAFTER
COLUMN CONNECTION DETAIL
FOR SPAN $10'-0'' < L \le 16'-0''$**

SCALE: NTS

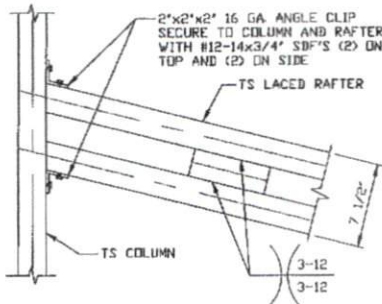

15B

**LEAN-TO RAFTER TO RAFTER
COLUMN CONNECTION DETAIL
FOR SPAN $16'-0'' < L \le 24'-0''$**

SCALE: NTS

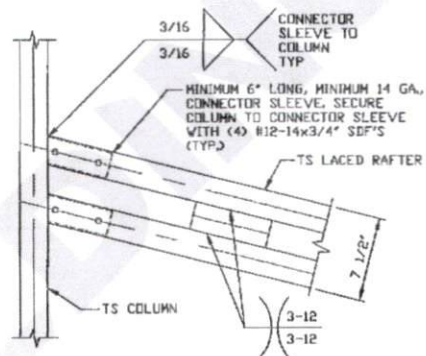

15C

**LEAN-TO RAFTER TO RAFTER
COLUMN CONNECTION DETAIL
FOR SPAN $16'-0'' < L \le 24'-0''$**

SCALE: NTS

**MOORE AND ASSOCIATES
ENGINEERING AND CONSULTING, INC.**

DRAWN BY: LT

CHECKED BY: PDH

PROJECT MGR: WSM

CLIENT: TOL

TOL BUILDINGS, INC.
P.O. BOX 542
TOAST, NC 27049
30'-0" x 20'-0" ENCLOSED STRUCTURE

DATE: 3-21-22

SCALE: NTS

DWG. NO: SK-3

JOB NO:
19164S/22020S

SHT. 14A

REV: 1

THIS DOCUMENT IS THE PROPERTY OF MOORE AND ASSOCIATES ENGINEERING AND CONSULTING. THE UNAUTHORIZED REPRODUCTION, COPYING, OR OTHERWISE USE OF THIS DOCUMENT IS STRICTLY PROHIBITED AND ANY INFRINGEMENT THEREUPON MAY BE SUBJECT TO LEGAL ACTION.

BOW RAFTER LEAN-TO OPTION

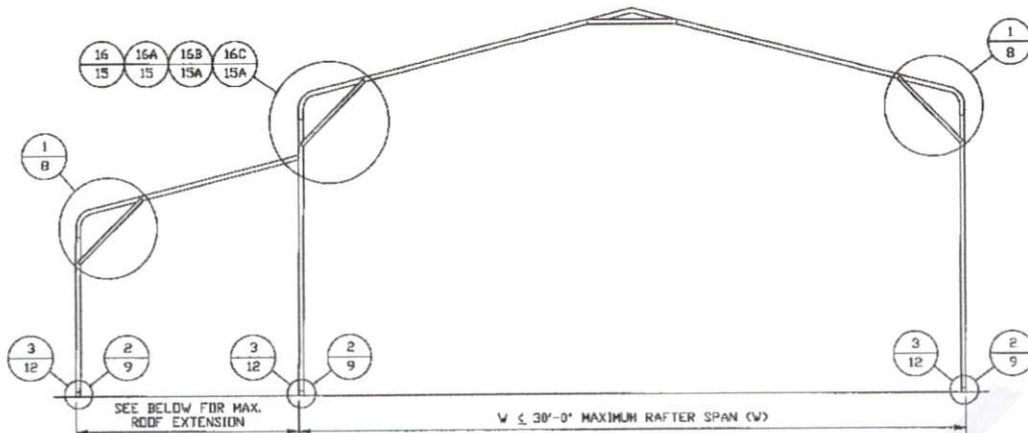

TYPICAL BOW EAVE RAFTER LEAN-TO OPTION FRAMING SECTION

SCALE: NTS

MAXIMUM WIDTH OF SINGLE MEMBER ROOF EXTENSION AND LEAN-TO IS 10'-0".
 MAXIMUM WIDTH OF DOUBLE MEMBER ROOF EXTENSION AND LEAN-TO IS 16'-0".
 MAXIMUM WIDTH OF LACED MEMBER ROOF EXTENSION AND LEAN-TO IS 24'-0".
 MAIN BUILDING COLUMNS WITH LEAN-TO OR ROOF EXTENSION ATTACHED ARE REQUIRED TO BE LACED COLUMNS FOR EAVE HEIGHTS 14'-0" < TO ≤ 20'-0".
 MAIN BUILDING COLUMNS WITH LEAN-TO OR ROOF EXTENSION ATTACHED ARE REQUIRED TO BE DOUBLE COLUMNS FOR EAVE HEIGHTS 10'-0" < TO ≤ 16'-0".
 MAIN BUILDING COLUMNS WITH LEAN-TO OR ROOF EXTENSION ATTACHED ARE REQUIRED TO BE SINGLE COLUMNS WITH INSERTS FOR EAVE HEIGHTS 9'-0" < TO ≤ 12'-0".
 MAIN BUILDING COLUMNS WITH LEAN-TO OR ROOF EXTENSION ATTACHED ARE REQUIRED TO BE SINGLE COLUMNS FOR EAVE HEIGHTS ≤ 9'-0".

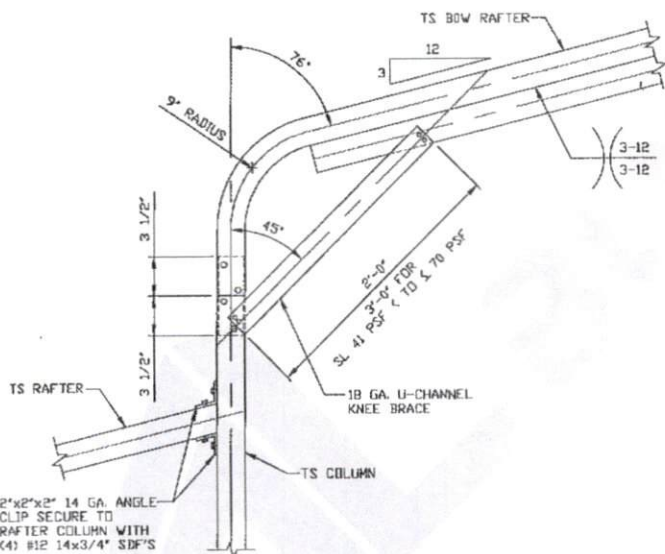

LEAN-TO RAFTER TO RAFTER COLUMN CONNECTION DETAIL FOR SPAN ≤ 10'-0"

16

SCALE: NTS

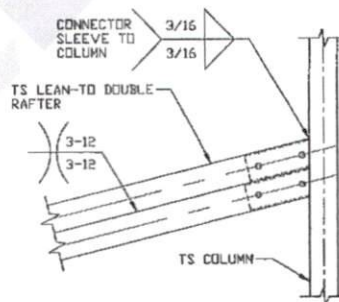

LEAN-TO RAFTER TO RAFTER COLUMN CONNECTION DETAIL FOR SPAN 10'-0" < L ≤ 16'-0"

16A

SCALE: NTS

**MOORE AND ASSOCIATES
ENGINEERING AND CONSULTING, INC.**

DRAWN BY: LT

CHECKED BY: PDH

PROJECT MGR: VSM

CLIENT: TDL

TOL BUILDINGS, INC.
P.O. BOX 542
TOAST, NC 27049
30'-0" x 20'-0" ENCLOSED STRUCTURE

DATE: 3-21-22

SHT. 15

SCALE: NTS

DWG. NO: SK-3

JOB NO:
19164S/22020S

REV: 1

THIS DOCUMENT IS THE PROPERTY OF MOORE AND ASSOCIATES ENGINEERING AND CONSULTING. THE UNAUTHORIZED REPRODUCTION, COPYING, OR OTHERWISE USE OF THIS DOCUMENT IS STRICTLY PROHIBITED AND ANY INFRINGEMENT THEREUPON MAY BE SUBJECT TO LEGAL ACTION.

BOW RAFTER LEAN-TO OPTION

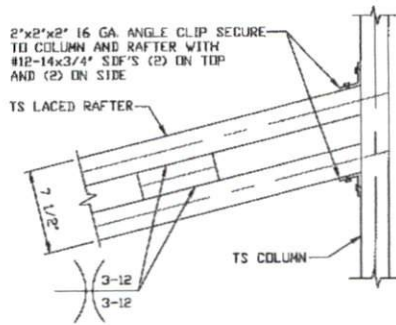

15B

LEAN-TO RAFTER TO RAFTER COLUMN CONNECTION DETAIL FOR SPAN 16'-0" < L ≤ 24'-0"
SCALE: NTS

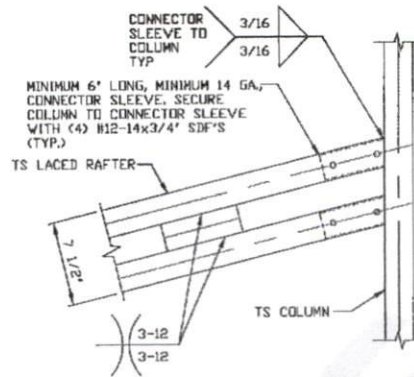

15C

LEAN-TO RAFTER TO RAFTER COLUMN CONNECTION DETAIL FOR SPAN 16'-0" < L ≤ 24'-0"
SCALE: NTS

MOORE AND ASSOCIATES
ENGINEERING AND CONSULTING, INC.

DRAWN BY: LT

CHECKED BY: PDH

PROJECT MGR: WSH

CLIENT: TOL

TOL BUILDINGS, INC.
P.O. BOX 542
TOAST, NC 27049
30'-0" x 20'-0" ENCLOSED STRUCTURE

DATE: 3-21-22

SHT. 15A

SCALE: NTS

DWG. NO: SK-3

JOB NO:
19164S/22020S

REV: 1

THIS DOCUMENT IS THE PROPERTY OF MOORE AND ASSOCIATES ENGINEERING AND CONSULTING. THE UNAUTHORIZED REPRODUCTION, COPYING, OR OTHERWISE USE OF THIS DOCUMENT IS STRICTLY PROHIBITED AND ANY INFRINGEMENT THEREUPON MAY BE SUBJECT TO LEGAL ACTION.

BOX EAVE RAFTER VERTICAL ROOF OPTION

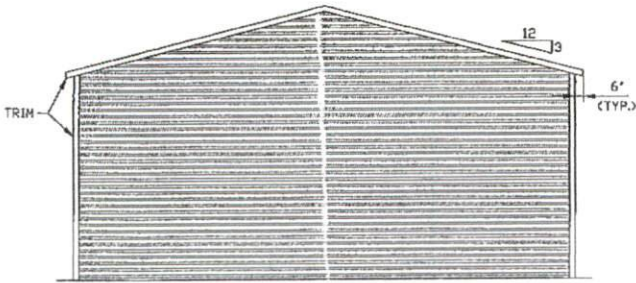

TYPICAL END ELEVATION-VERTICAL ROOF
SCALE: NTS

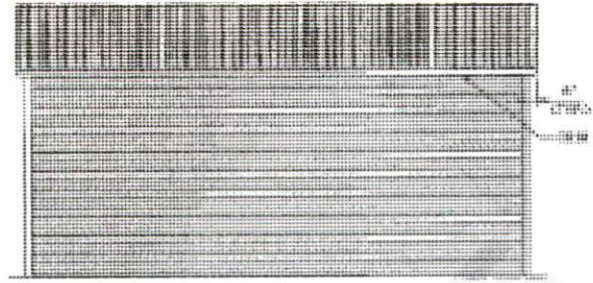

TYPICAL SIDE ELEVATION-VERTICAL ROOF OPTION
SCALE: NTS

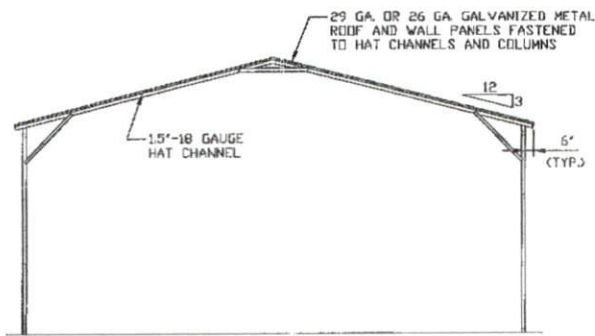

TYPICAL SECTION-VERTICAL ROOF
SCALE: NTS

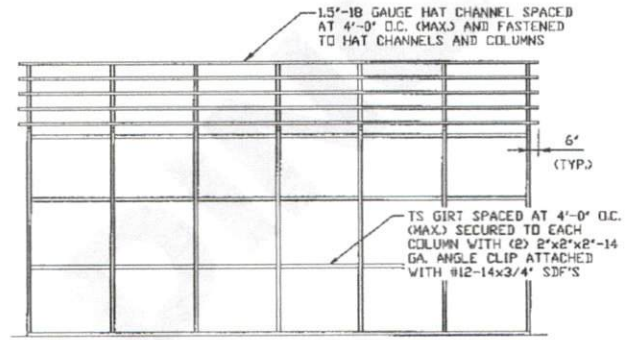

TYPICAL FRAMING SECTION-VERTICAL ROOF OPTION
SCALE: NTS
NOTE: HAT CHANNELS CAN BE USED AS AN OPTION IN PLACE OF TS GIRTS. HAT CHANNELS MUST BE SPACED AT 4'-0" O.C. (MAX.) AND FASTENED TO EACH COLUMN (LEG) WITH #12-14x3/4" SDF'S.

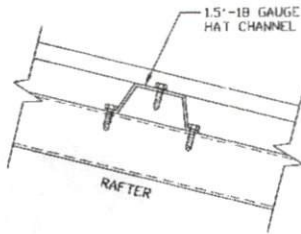

ROOF PANEL ATTACHMENT
(ALTERNATE FOR VERTICAL ROOF PANELS)
SCALE: NTS

**MOORE AND ASSOCIATES
ENGINEERING AND CONSULTING, INC.**

DRAWN BY: LT
CHECKED BY: PDH

TOL BUILDINGS, INC.
P.O. BOX 542
TOAST, NC 27049
30'-0"x20'-0" ENCLOSED STRUCTURE

THIS DOCUMENT IS THE PROPERTY OF MOORE AND ASSOCIATES ENGINEERING AND CONSULTING. THE UNAUTHORIZED REPRODUCTION, COPYING, OR OTHERWISE USE OF THIS DOCUMENT IS STRICTLY PROHIBITED AND ANY INFRINGEMENT THEREUPON MAY BE SUBJECT TO LEGAL ACTION.

PROJECT MGR: WSM
CLIENT: TOL

DATE: 3-21-22
SHT. 16

SCALE: NTS
DWG. NO: SK-3

JOB NO: 19164S/22020S
REV: 1

SIDE WALL HEADER OPTIONS

41 PSF < TO ≤ 70 PSF

NOTE: HEADER DESIGN DOES NOT TAKE IN TO ACCOUNT ADDITIONAL ROOF LOADING FROM ATTACHED LEAN-TO STRUCTURES.

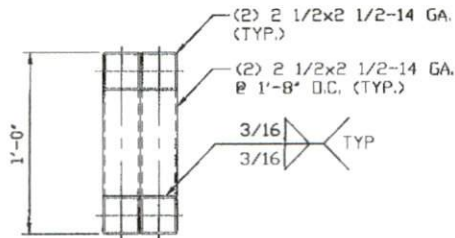

HEADER DETAIL FOR SIDE WALL DOOR OPENINGS 15'-0" < LENGTH ≤ 20'-0"

SCALE: NTS

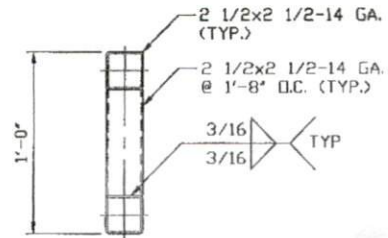

HEADER DETAIL FOR SIDE WALL DOOR OPENINGS 8'-0" < LENGTH ≤ 15'-0"

SCALE: NTS

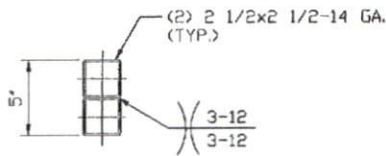

HEADER DETAIL FOR SIDE WALL DOOR OPENINGS ≤ 8'-0"

SCALE: NTS

SIDE WALL HEADER OPTIONS

≤ 40 PSF

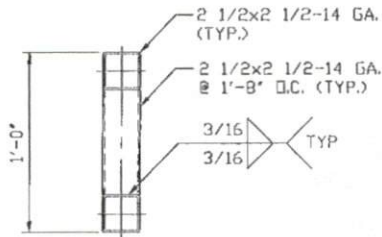

HEADER DETAIL FOR SIDE WALL DOOR OPENINGS 10'-0" < LENGTH ≤ 20'-0"

SCALE: NTS

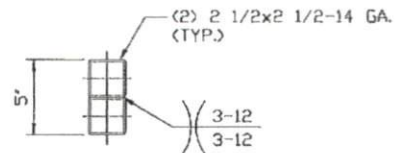

HEADER DETAIL FOR SIDE WALL DOOR OPENINGS ≤ 10'-0"

SCALE: NTS

**MOORE AND ASSOCIATES
ENGINEERING AND CONSULTING, INC.**

DRAWN BY: LT

CHECKED BY: PDH

PROJECT MGR: VSM

CLIENT: TOL

TOL BUILDINGS, INC.
P.O. BOX 542
TOAST, NC 27049
30'-0"x20'-0" ENCLOSED STRUCTURE

DATE: 3-21-22

SHT. 17

SCALE: NTS

DWG. NO. SK-3

**JOB NO:
19164S/22020S**

REV: 1

THIS DOCUMENT IS THE PROPERTY OF MOORE AND ASSOCIATES ENGINEERING AND CONSULTING. THE UNAUTHORIZED REPRODUCTION, COPYING, OR OTHERWISE USE OF THIS DOCUMENT IS STRICTLY PROHIBITED AND ANY INFRINGEMENT THEREUPON MAY BE SUBJECT TO LEGAL ACTION.

END WALL HEADER OPTIONS

NOTE: HEADER DESIGN DOES NOT TAKE IN TO ACCOUNT ADDITIONAL ROOF LOADING FROM ATTACHED LEAN-TO STRUCTURES.

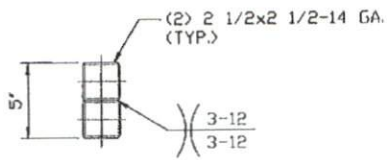

HEADER DETAIL FOR SIDE WALL DOOR OPENINGS 13'-0" < LENGTH ≤ 20'-0"

SCALE: NTS

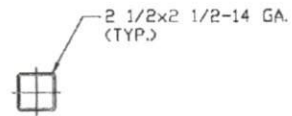

HEADER DETAIL FOR SIDE WALL DOOR OPENINGS ≤ 13'-0"

SCALE: NTS

**MOORE AND ASSOCIATES
ENGINEERING AND CONSULTING, INC.**

DRAWN BY: LT

CHECKED BY: PDH

PROJECT MGR: WSM

CLIENT: TOL

TOL BUILDINGS, INC.

P.O. BOX 542

TOAST, NC 27049

30'-0"x20'-0" ENCLOSED STRUCTURE

DATE: 3-21-22

SHT. 18

SCALE: NTS

DWG. NO: SK-3

JOB NO:

19164S/22020S

REV: 1

THIS DOCUMENT IS THE PROPERTY OF MOORE AND ASSOCIATES ENGINEERING AND CONSULTING. THE UNAUTHORIZED REPRODUCTION, COPYING, OR OTHERWISE USE OF THIS DOCUMENT IS STRICTLY PROHIBITED AND ANY INFRINGEMENT THEREUPON MAY BE SUBJECT TO LEGAL ACTION.