



December 7, 2022

Mr. Mike Hamm, P.E.
State of North Carolina
Department of Insurance
Manufactured Building Division
1202 Mail Service Center
Raleigh, NC 27699-1202

RE: R-Anell Housing Group. LLC
Model 1B1503-R36-NC

Dear Mr. Hamm,

Enclosed, you will find one (1) copy of the above-mentioned project for your files.

Should you have any questions or comments, please contact me at your earliest convenience.

Sincerely,

Roger Colson

Roger Colson
Account Manager
ICC-NTA LLC

Adopted Codes: State of North Carolina

- 2018 North Carolina Residential Code
- 2017 North Carolina Electrical Code (2017 NEC)
- 2018 North Carolina Energy Code
- 2018 North Carolina Mechanical Code
- 2018 North Carolina Plumbing Code

Project Location:

74 Bait Road
 Dunn, NC 28334
 HARNETT County

Occupancy:

Occupancy:IRC - Single Family Dwelling
 Construction Type:5B (Wood Frame - Unprotected)
 Number of Stories:One Story Ranch

Design Load:

Floor Area:2077 Sq.Ft. Floor Live Load:40 psf
 Ground Snow Load:20 psf Floor Dead Load:10 psf
 Top Chord Dead Load:10 psf Bottom Chord Live Load:.....N/A psf
 Ultimate Wind Speed: 130 mph Wind Exposure Category:B
 Seismic Design Category: ...C IECC Geographical Code:4

Insulation

Reference RESCheck for Requirements.

Attention Local Inspection Departments:

1. Set-up instructions for this modular unit are included by attachment to these plans. Any plans set that does not include an attachment entitled "MODULAR HOME INSTALLATION MANUAL" is incomplete.
2. The following items are not completed by the home manufacturer, are not inspected by in-factory third party inspectors, and are not certified by the modular compliance label: (A) Components or connections for heating or air conditioning systems which are NOT part of the factory installation. (B) Below floor ducts. (C) Electrical service disconnect. (D) Foundation designs and attachments. In order to verify that all required systems connections are complete, refer to the "Inspection Check Sheet" in the manufacturer's modular home installation manual. Regardless of factory or site installation, the furnace, water heater, and all elements of heating system must be per applicable codes, (refer to ResCheck if applicable).
3. Site installed furnace must meet IECC Energy Efficiency Certificate if applicable.
4. This unit must be connected to a public water supply and sewer system if these are available.
5. **If this structure is in a thermal zone more stringent than that listed on these plans, is set on pilings, or is installed at a mountain region or coastal high hazard site such that wind or other design parameters are increased, the design must be determined to be adequate for actual site conditions. Alterations may be required to bring the home into compliance with the more stringent conditions.**
6. Soffit materials for this unit assume that the building face will be 10 feet or greater from the property line when installed on site. Where the building face is less than 10 feet from the property line, underlayment materials and ventilation in accordance with **Section R302.1.1, NC Residential Code**, must be provided and installed at the site and inspected by the local jurisdiction.
7. If after installation of this home, the lowest part of the clear opening of any window is more than 72" above the finished grade, guards will be required to be installed onsite in accordance with **Section R312**; subject to local inspection.
8. Partial plumbing installation (stubbed in) requires full DWV testing in field. Testing of factory portion of DWV is not required unless partial testing is mandated by code.
9. Smoke detectors required by code that are not shown on the plan will be site installed by others and are subject to inspection by the authority having jurisdiction.
10. Where required, window protection designed and provided on site by others to meet applicable local codes.

Model: 1B1503-R36
 Customer: HILL
 Builder: CUSTOM BUILT
Manufacturer:
R-Anell Housing Group, LLC
 Commodore Homes, LLC
 235 Anthony Grove Rd.
 Crouse, NC 28033



FRONT VIEW

Drawing Index

Title	Page
Cover	CV
Floor Plan	FP
Electrical Plan	EP
Schedules and General Notes	NG
Elevations	EL
Cross Section	XS
Hot Water Lines	WH
Cold Water Lines	WC
DWV System	DL
DWV Notes	DN
Supply Air Ducts - Perimeter Registers	SP
Ceiling Return Air System	HR
Braced Walls-Prescriptive	BWP
Foundation 2x10 Marriage Line without Stair	FD20#
Manual J Calculations	ATTACHED
ResCheck	ATTACHED
Truss Diagram	ATTACHED

APPROVED BY

 12/7/2022
 Approval of this document does not authorize or approve any deviation or deviations from the requirements of applicable State Laws.
 Roger Colson

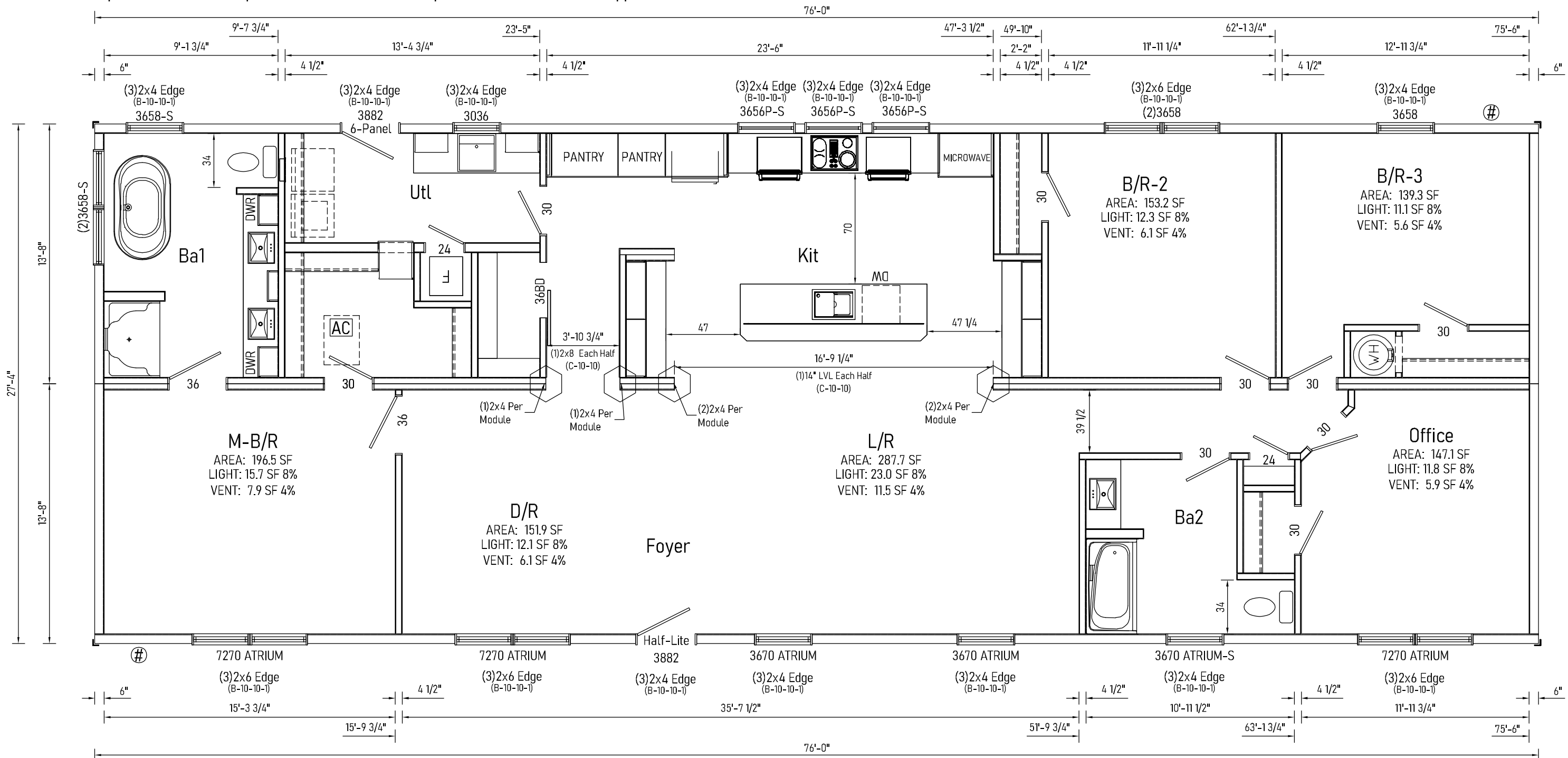
Note: Window fall protection must be provided on-site where required in accordance with applicable code.



See Schedules and General Notes Page

⬡ = Column Support Location

AC = Attic Access

Note:
* LVLs noted must extend past column on at least one end 24" minimum and be overlaid with OSB sheathing.

- Notes:
1. Exterior opening headers and jack studs are SPF #2 unless otherwise noted.
 2. Sidewall headers may use alternate construction per section B-10 of Systems Manual.
 3. LVL's where specified to be minimum of 1 1/2" wide, M.O.E. = 2.0 and fb = 2900 PSI.
 4. See C-10-45 for stair opening framing.
 5. See C-10-105 for dormer opening framing.

APPROVED BY



12/7/2022

Approval of this document does not authorize or approve any deviation or deviations from the requirements of applicable State Laws.
Roger Colson

Builder: R-Anell Housing Group, LLC - Subsidiary of The Commodore Corp.

Title: Floor Plan

Callout: 2876

Revisions

Scale: 3/16" = 1'-0"

Date: 11/30/2022

Cust: HILL

Drawn By: NE

Reference: NONE

Dlr: CUSTOM BUILT

S/N: 43906

Pg:

Model/Eng. No.: 1B1503-R36
FP

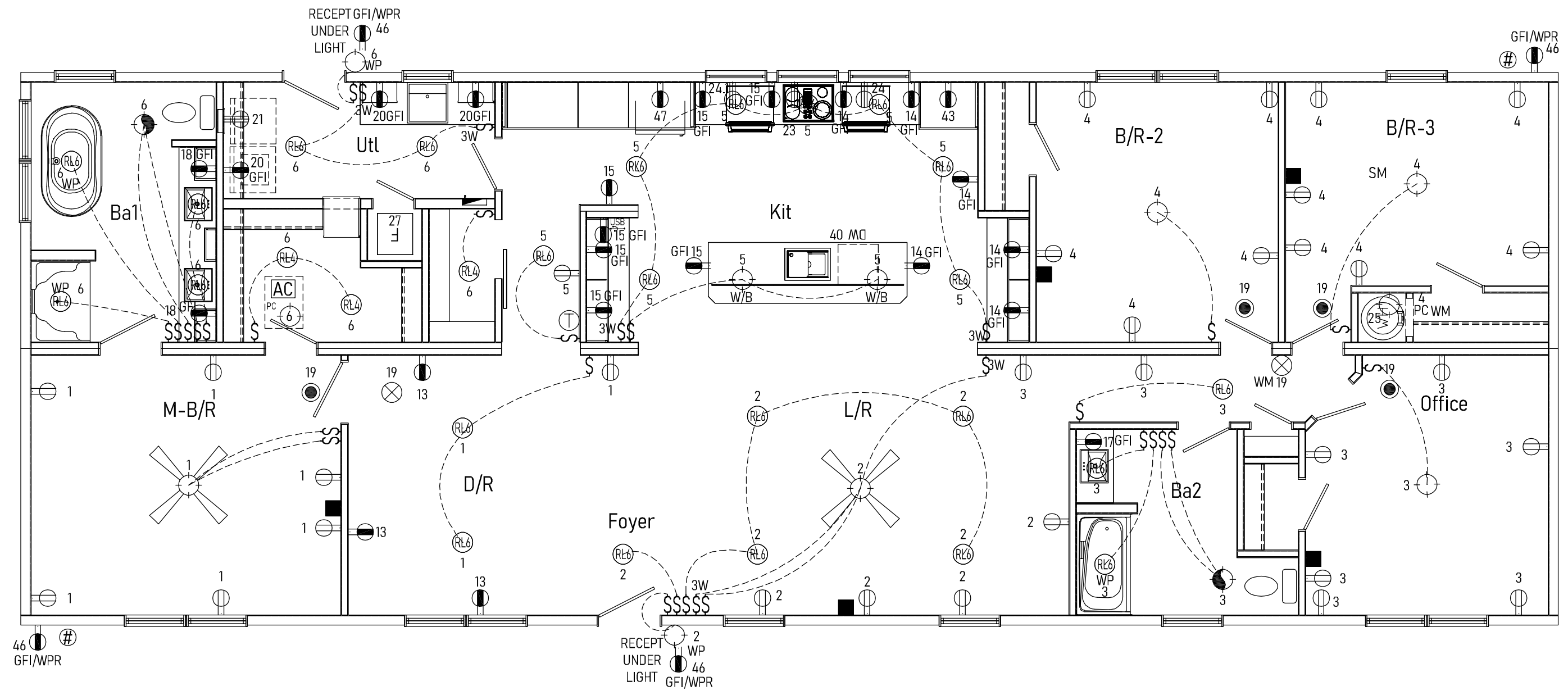

APPROVED BY
NIA 12/7/2022
 Approval of this document does not authorize or approve any deviation or deviations from the requirements of applicable State Laws.
 Roger Colson

See Schedules and General Notes Page

Builder: R-Anell Housing Group, LLC - Subsidiary of The Commodore Corp.	Callout: 2876	Revisions:	Scale: 3/16" = 1'-0"	Date: 11/30/2022	Cust: HILL
Title: Electrical Plan		Drawn By: NE	Reference: NONE		Dlr: CUSTOM BUILT
					S/N: 43906
					Pg.: EP

Optional Method Load Calculation for One-Family Dwellings		Model # 1B1503-R36																									
1 General Lighting and Receptacle Loads 220.82(B)(1) <i>Do not include open porches, garages, or unused or unfinished spaces not adaptable for future use.</i>	3 x 2077 = (ft ² using outside dimensions)	1	6231																								
2 Small-Appliance Branch Circuits 220.82(B)(2) <i>At least two small-appliance branch circuits must be included. 210.11(C)(1)</i>	1500 x 3 = (minimum of two)	2	4500																								
3 Laundry Branch Circuits(s) 220.82(B)(2) <i>At least one laundry branch circuit must be included. 210.11(C)(2)</i>	1500 x 1 = (minimum of one)	3	1500																								
4 Appliances 220.82(B)(3) and (4) <i>Do NOT include any heating or Use the nameplate rating of all appliances (fastened in place, permanently connected, or connected to a specific circuit), ranges, ovens, cooktops, motors, and clothes dryers. Convert any nameplate rating given in amperes to volt-amperes by multiplying the amperes by the rated voltage.</i>	Total volt-amperes of all app. LISTED BLEOW	4	32600																								
<table border="0"> <tr> <td>(1) Electric H₂O Heater</td> <td>4.5 KVA</td> <td>(2) Vent Fans</td> <td>0.6 KVA</td> </tr> <tr> <td>(1) Electric Dryer</td> <td>5.4 KVA</td> <td>(1) Microwave</td> <td>1.5 KVA</td> </tr> <tr> <td>(1) Electric Cooktop</td> <td>7.4 KVA</td> <td>(1) Dishwasher</td> <td>1.5 KVA</td> </tr> <tr> <td>(2) Electric Wal Oven (S)</td> <td>7.2 KVA</td> <td>(1) Refrigerator</td> <td>1.5 KVA</td> </tr> <tr> <td>(0) Electric Wal Oven (D)</td> <td>0 KVA</td> <td></td> <td></td> </tr> <tr> <td>(2) Bath Circ's</td> <td>3 KVA</td> <td></td> <td></td> </tr> </table>		(1) Electric H ₂ O Heater	4.5 KVA	(2) Vent Fans	0.6 KVA	(1) Electric Dryer	5.4 KVA	(1) Microwave	1.5 KVA	(1) Electric Cooktop	7.4 KVA	(1) Dishwasher	1.5 KVA	(2) Electric Wal Oven (S)	7.2 KVA	(1) Refrigerator	1.5 KVA	(0) Electric Wal Oven (D)	0 KVA			(2) Bath Circ's	3 KVA				
(1) Electric H ₂ O Heater	4.5 KVA	(2) Vent Fans	0.6 KVA																								
(1) Electric Dryer	5.4 KVA	(1) Microwave	1.5 KVA																								
(1) Electric Cooktop	7.4 KVA	(1) Dishwasher	1.5 KVA																								
(2) Electric Wal Oven (S)	7.2 KVA	(1) Refrigerator	1.5 KVA																								
(0) Electric Wal Oven (D)	0 KVA																										
(2) Bath Circ's	3 KVA																										
5 Apply 220.82(B) demand factor to the total of lines 1 through 4. 44831 - 10,000 = 34831 x 40% = 13932 + 10,000 = 23932 (total of lines 1-4)																											
6 Heating or Air-Conditioning System 220.82(C). <i>Use the nameplate ratings in volt-amperes for all applicable systems in lines a through e.</i>		c) Supplemental electric heating equipment for heat-pump systems. Include the heat-pump compressor(s) at 100%. If the heat-pump compressor is prevented from operating with the supplemental heat, omit the compressor.																									
a) Air-conditioning and cooling systems, including heat pumps without any supplemental electric heating: 6000 x 100% = a) 6000		d) Electric space-heating equipment, if fewer than four separately controlled units: 20000 x 65% = d) 13000																									
b) Electric thermal storage & other heating systems where the usual load is expected to be continuous at full nameplate value. Systems qualifying under this selection shall not be figured under any other selection in 220.82(C). 0 x 100% = b) 0		e) Electric space-heating equipment, if four or more separately controlled units: 0 x 40% = e) 0																									
7 Total Volt-Ampere Demand Load: (Largest VA rating, 6a - 6e)		7 36932																									
8 Minimum Amperes Divide the total volt-amperes by voltage. (line 7) (voltage) (min. amperes)		9 Minimum Size Service or Feeder 200 Amps Installed																									
10 Size the Service or Feeder Conductors. Use 310.15(B)(6) to find the service conductor up to 400 amperes. Ratings in excess of 400 amperes shall comply w/ Table 310.16. 310.15(B)(6) also applies to feeder conductors serving as the main power feeder.		10 Minimum Size Conductors 2/0 Copper OR 4/0 Aluminum																									

LEGEND			
		WPR = WEATHERPROOF ENCLOSURE WITH WEATHER RESISTANT RECEPT	

CIRCUIT ID NO.	LOAD	AMPS	POLES REQ'D	WIRE SIZE
1-12	General Lighting/Receptacles	15	1	NM14-2/WG
13-16	Small Appliance	20	1	NM12-2/WG
17-18	Bath (GFCI)	20	1	NM12-2/WG
19	Smoke Alarms (AFCI)	15	1	NM14-2/WG
20	Laundry	20	1	NM12-2/WG
21	Electric Dryer	30	2	NM10-3/WG
22	Electric Range	50	2	NM6-3/WG
23	Electric Cooktop	40	2	NM8-3/WG
24	Electric Wall Oven	20	2	NM12-2/WG
	Electric Wall Oven	40	2	NM8-2/WG
25	Electric W/H	25	2	NM10-2/WG
25.1	Tankless W/H	20	1	NM12-2/WG
26	Gas Furnace	15	1	NM14-2/WG
27	Electric Furnace	60/30	4	NM4-2/WG
	Electric Furnace	60/60	4	NM4-2/WG
28-37	Electric BB Heat	20	2	NM12-2/WG
38	A/C	50	2	NM6-2/WG
39	Freezer	20	1	NM12-2/WG
40	Dishwasher	15	1	NM14-2/WG
41	Disposal (GFCI)	15	1	NM14-2/WG
42	Whirlpool Tub (GFCI)	20	1	NM12-2/WG
43	Microwave Oven	20	1	NM12-2/WG
44	Garage (GFCI)	20	1	NM12-2/WG
46	Exterior Receptacles	15 (Opt. 20)	1	NM14-2/WG (Opt. NM12-2/WG)
47	Refrigerator	20	1	NM12-2/WG

Doors Exterior							
Door Type	Size	Width	Height	RO SF	Light	Vent	Design Load
9 Lite	3476	2'-10"	6'-4"	17.94	4.38	16.26	50
6 Panel Fire Rated	3680	3'-1"	6'-9 1/8"	20.85	0	19.93	50
2 Lite	3882	3'-2"	6'-10"	21.64	0.51	20	50
Oval	3882	3'-2"	6'-10"	21.64	5.73	20	50
9 Lite	3882	3'-2"	6'-10"	21.64	4.378	20	50
Sunburst	3882	3'-2"	6'-10"	21.64	0.893	20	50
15 Lite	3882	3'-2"	6'-10"	21.64	7.073	20	50
Slider	7280	6'-0"	6'-8"	40.00	32.13	16.2	50
Exterior Door	3482	2'-10"	6'-10"	20.00	0	17.78	50
Atrium	7582	6'-3"	6'-8"	42.70	14.69	19.45	50
Atrium	7276	6'-3 1/2"	6'-4 1/4"	39.98	18.5	17.72	50
French	7282	6'-3 1/2"	6'-10 1/4"	43.15	18.4	38.4	50
Side Light	1782	1'-4 1/2"	6'-10"	10.25	1.85	-	50
Half Lite	3882	3'-2"	6'-10 1/4"	21.70	9.25	19.13	50
Atrium	7280	6'-3 1/8"	6'-10"	42.78	18.4	19.2	35
1-Lite	3882	3'-2"	6'-10 1/4"	21.70	5.45	19.125	50
1617 RD Patio	9868	9'-7 3/4"	6'-8"	64.31	46.83	22.74	35
10068-SG Patio	10068	9'-11 3/4"	6'-8 3/4"	67.15	62.38	22.74	35
6 Panel	3882	3'-2"	6'-10 1/2"	21.73	0	20	50
3/4-Lite	3882	3'-2"	6'-10 1/4"	21.70	1.45	19.13	50

STAIRWAYS
RISER HEIGHT - 8 1/4" MAX.
TREAD DEPTH - 9" MIN.
HEAD ROOM 80" MIN.
 NOTE: THE STAIRWELL GEOMETRY IN THIS HOME HAS BEEN DESIGNED TO THE CRITERIA ABOVE. IF MORE STRINGENT STAIR GEOMETRY IS REQUIRED OR DESIRED, PLEASE CONTACT THE PLANT OF MANUFACTURE FOR PLAN ADJUSTMENTS.

Doors Interior			
Door Type	Size	Width	Height
Int. Passage	24	2'-2 1/8"	6'-11"
Int. Passage	28	2'-6 1/8"	6'-11"
Int. Passage	30	2'-8 1/8"	6'-11"
Int. Passage	32	2'-10 1/8"	6'-11"
Int. Passage	36	3'-2 1/8"	6'-11"
Int. Passage	48	4'-1"	6'-11"

- ELECTRICAL PLAN NOTES BASED ON NEC 2017:**
- ALL KITCHEN AND BATHROOM COUNTER RECEPTS TO BE GFCI PROTECTED.
 - ALL CLOSET LIGHTS TO BE ENCLOSED SURFACE MOUNT FIXTURES, 12" MIN. FROM STORAGE SPACE.
 - ALL RECEPTS TO BE GROUNDING TYPE, PER 210-7/NEC.
 - SPECS, WIRING, INSTALLATIONS, ETC. TO COMPLY WITH NEC REGULATIONS.
 - SERVICE PANEL MAY BE LOCATED IN GARAGE.
 - ALL SMOKE ALARMS TO HAVE BATTERY BACK-UP AND TO BE INTERCONNECTED WITH A 14 GA. MIN. INTERCONNECTION WIRE, 14-3 CABLE, OR EQUIVALENT PER MFG.S RECOMMENDATIONS.
 - EXTERIOR LIGHT AT GARAGE SIDE MAY BE REPLACED.
 - GAS APPLIANCES MAY BE SUBSTITUTED FOR ELECTRIC APPLIANCES WHERE APPLICABLE. WHEN GAS APPLIANCES ARE INSTALLED, ALL GAS PIPING, CONNECTIONS, HOOK-UPS, ETC. TO BE INSTALLED ON SITE BY OTHERS. THE OPTIONAL GARBAGE DISPOSAL CONNECTED TO INDEPENDENT RECEPTACLE AND WALL SWITCH.
 - 200 AMP PANEL BOX INSTALLED
 - ALL 120v GENERAL USE RECEPTS ARE TAMPER RESISTANT UNLESS MOUNTED AT LEAST 66" ABOVE FLOOR, OR ARE PART OF A LISTED LIGHT FIXTURE OR APPLIANCE, OR WHERE CORD & PLUG APPLIANCE IN DEDICATED SPACE IS NOT EASILY MOVED FOR USE.
 - ALL EXTERIOR RECEPTACLES ARE GFI, TAMPER RESISTANT AND LISTED FOR WET LOCATIONS.
 - COMBINATION TYPE AFCI BREAKERS ARE REQUIRED FOR ALL 120 V CIRCUITS EXCEPT THOSE SERVING BATHROOMS, GARAGE, LAUNDRY AREAS, KITCHENS, UNFINISHED BASEMENTS AND OUTDOORS.
 - ALL ELECTRICAL BOXES SUPPORTING LIGHTING FIXTURES MUST BE RATED @ 50# AND IDENTIFIED ON THE BOX.
 - WHIRLPOOL RECEPTACLES MUST BE GFCI, TAMPER RESISTANT AND READILY ACCESSIBLE PER NEC 680.71
 - A CIRCUIT BREAKER LOCKING DEVICE SHALL BE PROVIDED TO LOCK THE APPLICABLE BREAKERS IN THEIR "OFF" POSITION. THIS APPLIES TO CIRCUIT BREAKERS WHICH SERVE AS THE DISCONNECT FOR ELECTRIC WATER HEATERS, ELECTRIC BASEBOARD HEATERS, AND ANY APPLIANCE RATED OVER 300 WATTS OR 1/8 HORSEPOWER, WHICH ARE NOT LOCATED WITHIN CLEAR SIGHT OF THEIR DISCONNECT
 - A RECEPTACLE OUTLET IS REQUIRED FOR PORCHES, BALCONIES OR DECKS WHICH ARE ACCESSIBLE FROM THE INSIDE OF THE DWELLING UNIT REGARDLESS OF THE SIZE OF THE PORCH, BALCONY OR DECK.
 - NON-SWITCHED CIRCUIT NEUTRAL CONDUCTOR MUST BE PRESENT AT EACH WALL SWITCH. RE-IDENTIFIED CONDUCTORS WITH WHITE, GREY OR THREE STRIPE INSULATION MAY ONLY BE USED AS SUPPLY TO SWITCH AND NOT FOR HOT RETURN TO FIXTURE.
 - 120v 15 OR 20 AMP RECEPTS LOCATED WITHIN 6' FROM ANY DWELLING UNIT SINK MUST BE GFCI PROTECTED.
 - IF THE PERIMETERS OF THE AREAS OF THE ON-SITE INSTALLED STOOPS, PORCHES OR DECKS ARE NOT UNDER THE EXTERIOR ELECTRICAL RECEPTACLES SHOWN IN THE ELECTRICAL FLOOR PLAN, THEN ADDITIONAL RECEPTACLES SHALL BE SITE INSTALLED WITHIN THESE AREAS BY THE CONTRACTOR.

REFER TO RESCHECK FOR DOOR AND WINDOW U-VALUES

WINDOW SCHEDULE - MOD SINGLE HUNG											
S SUFFIX DENOTES SAFETY GLAZING / E SUFFIX DENOTES EGRESS											
Label	Width R/O	Height R/O	R/O SF	Light	Vent	Room SF	U Value	Egress		Design Load	SHGC w/o Grids
								No	Yes		
3670 ATRIUM	36.5	71	17.99	13.91	5.76	144.00	0.34		●	50	0.24
3670 ATRIUM-S	36.5	71	17.99	13.91	5.76	144.00	0.34		●	50	0.24
7270 ATRIUM	73	70.75	35.86	28.03	11.52	288.00	0.34		●	50	0.24
3656P-S	36.5	56.5	14.32	12.33	0.00	0.00	0.33	●		50	0.24
3036	30.5	36.5	7.62	5.55	2.64	66.00	0.34	●		66	0.25
3658	36.5	58.5	14.66	11.76	5.76	144.00	0.34		●	50	0.25
3658-S	36.5	58.5	14.66	11.76	5.76	144.00	0.34		●	50	0.25
(2)3658	73	58.5	29.43	23.52	11.52	288.00	0.34		●	50	0.25
(2)3658-S	73	58.5	29.43	23.52	11.52	288.00	0.34		●	50	0.25

Builder: R-Anell Housing Group, LLC - Subsidiary of The Commodore Corp.	Callout: 2876	Revisions:	Scale: N.T.S.	Date: 11/30/2022	Cust: HILL
Title: Schedules and General Notes		Drawn By: NE	Reference: NONE		Dir: CUSTOM BUILT
					S/N: 43906
					Pg.: 1B1503-R36 NG

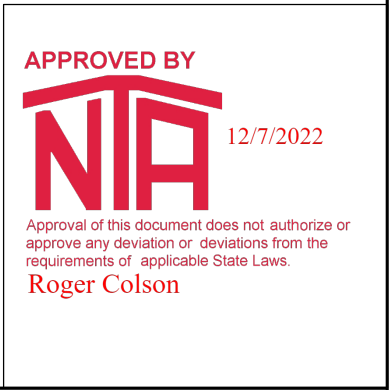

ELEVATIONS SHOWN ON THIS PAGE REPRESENT BASIC COMPONENTS AND ARE NOT INTENDED TO BE ALL INCLUSIVE, NOR DO THESE ELEVATIONS DETAIL EVERY CODE REQUIRED ASPECT OF THIS BUILDING. SITE BUILT STOOPS, STEPS, DECKS, PORCHES, HANDRAILS AND/OR SIMILAR ITEMS MUST BE PROVIDED BY OTHERS ON SITE FOR COMPLIANCE WITH APPLICABLE CODES. COMPLIANCE WITH ALL APPLICABLE CODES PER LOCAL AUTHORITY HAVING JURISDICTION, WHETHER DETAILED IN THIS SET OR NOT, MUST BE MET.

Note: Window fall protection must be provided on-site where required in accordance with applicable code.



FRONT VIEW

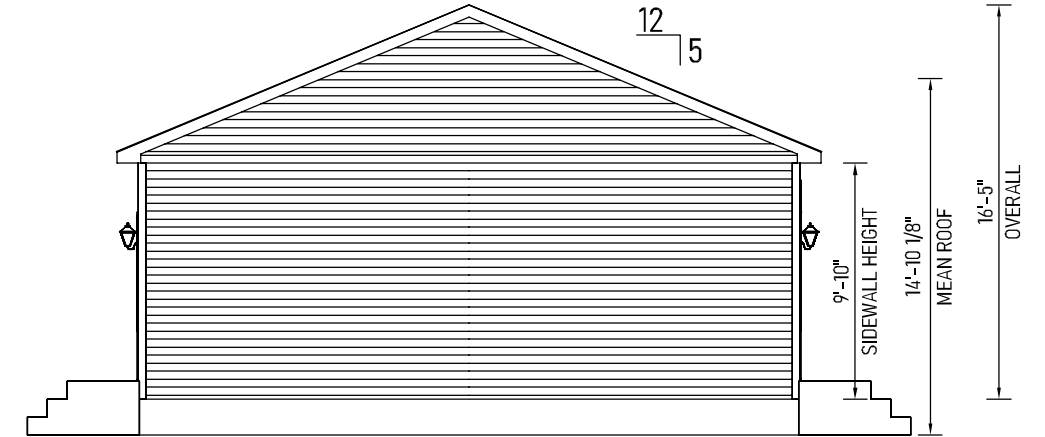

RIGHT VIEW

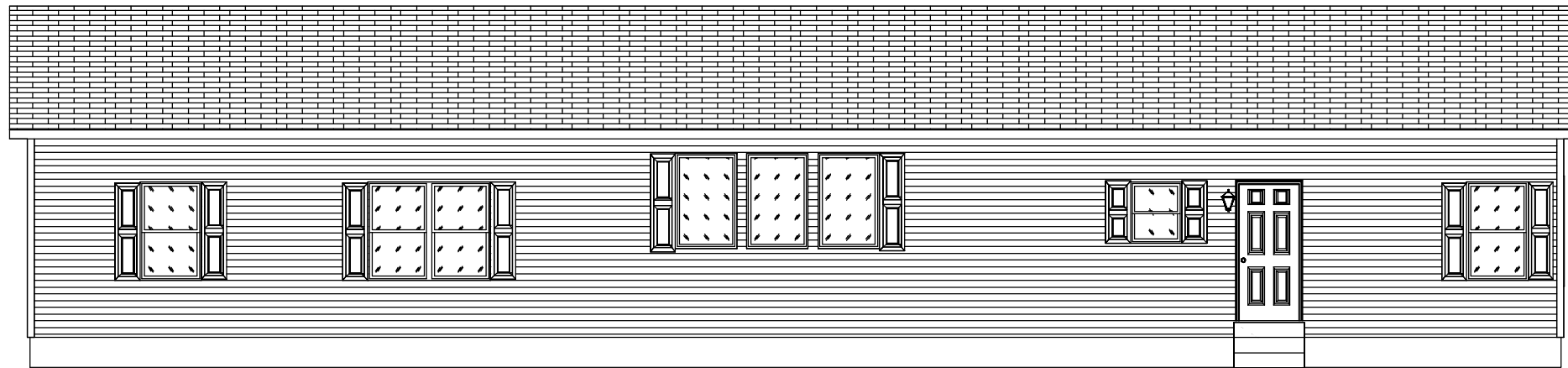

REAR VIEW

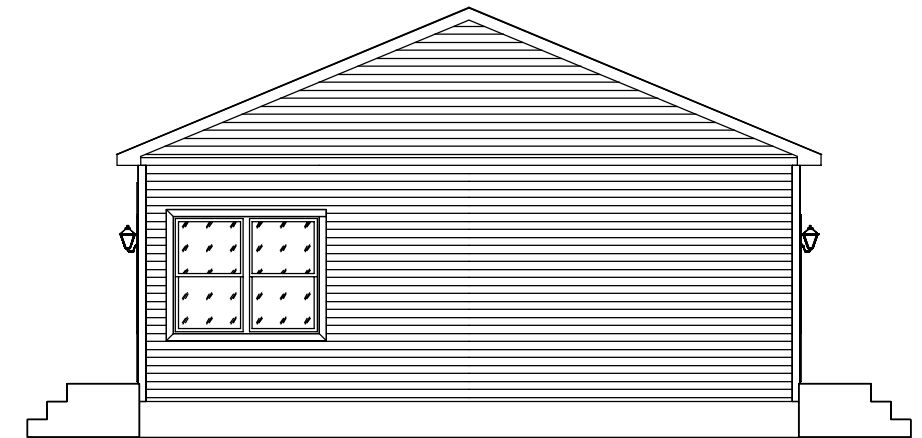

LEFT VIEW

-NOTES-

1. FOUNDATION SHALL BE DESIGNED AND CONSTRUCTED BY OTHERS WHERE "OTHERS" REFERS TO THE DEALER BUILDER.
2. GUTTERS AND LEADERS SHALL BE INSTALLED BY OTHERS.
3. TYPICAL 12" OR 15" VINYL SHUTTERS PROVIDED BY MANUFACTURERS.
4. ALL FOOTINGS, RAILINGS AND STEPS SHALL BE FIELD INSTALLED IN COMPLIANCE WITH APPLICABLE STATE AND LOCAL CODES.
5. SIDING SHALL BE VINYL SIDING WITH VINYL TRIM, AND MAY BE PARTIALLY INSTALLED ON SITE.
6. EXTERIOR LIGHTS MAY BE SHIPPED LOOSE FOR INSTALLATION ON SITE.
7. ROOFING SHINGLES MAY BE PARTIALLY SITE INSTALLED.
8. PORCH RAILINGS ARE PVC. TREATED LUMBER PORCH POSTS MAY BE COVERED WITH VINYL. PORCH DECKING SHALL BE TREATED.
9. ALL EXTERIOR COVERINGS SHALL BE WEATHER AND DECAY RESISTIVE TO PROVIDE PROPER PROTECTION FOR UNTREATED MATERIALS.

NOTE:

HOMES WITH ATTIC SPACE QUALIFYING AS HABITABLE, MUST BE EQUIPPED WITH EMERGENCY ESCAPE AND RESCUE OPENINGS REGARDLESS OF WHETHER ATTIC AREA IS FINISHED OR UNFINISHED. OPENINGS MAY OCCUR AT END WALL OF ATTIC AND/OR AT ROOF DORMERS IN WHATEVER ARRANGEMENT NECESSARY TO INSURE THAT ANY SLEEPING ROOM HAS AT LEAST ONE EGRESS OPENING.

APPROVED BY

 12/7/2022
 Approval of this document does not authorize or approve any deviation or deviations from the requirements of applicable State Laws.
Roger Colson

Builder: R-Anell Housing Group, LLC - Subsidiary of The Commodore Corp.	Callout: 2876	Revisions:	Scale: N.T.S.	Date: 11/30/2022	Cust#HILL
Title: Elevations		Drawn By: NE	Reference: NONE		Dlr: CUSTOM BUILT
					S/N: 43906

Model/Eng. No.:
1B1503-R36
 EL

- LEGEND**
- 1 JACK POST, PIER OR CONCRETE FILLED POST THAT MEETS OR EXCEEDS REQUIRED SUPPORT CAPACITY PER FOUNDATION DESIGN.
 - 2 EXTERIOR WALL INSULATION (SEE INSULATION R-VALUES).
 - 3 2X6 #3 SPF EXTERIOR WALL STUDS. (SEE STUD O.C. SPACING NOTE)
 - 4 2X6 #3 SPF SIDEWALL BOTTOM PLATE.
 - 5 7/16" RATED SHEATHING.
 - 6 VINYL OR HARDBOARD SIDING (RAN VERT. OR HORZ.) INSTALLED PER MFGR.'S INSTRUCTIONS.
 - 7 AIR INFILTRATION AND WATER RESISTANT BARRIER.
 - 8 2X4 #3 SPF SINGLE OR DOUBLE TOP PLATE.
 - 9 2X6 TREATED SILL PLATE. FASTENING OF SILL AND HOME TO FOUNDATION ON SITE PER CODES OR BY LOCAL ENGINEER WHEN APPLICABLE.
 - 10 2X4 #3 SPF INTERIOR WALL STUDS. (SEE STUD O.C. SPACING NOTE)
 - 11 2X4 #3 SPF BOTTOM PLATE INTERIOR WALLS, TYP.
 - 12 ENGINEERED TRUSSES SPACED TO MEET DESIGNED GROUND LOAD SNOW LOAD.
 - 13 VAPOR BARRIER.
 - 14 CEILING BOARD 1/2" GYPSUM.
 - 15 7/16" 24/16 RATED ROOF DECKING MIN. TYP.
 - 16 2X4 #3 SPF MIN. VERT. RAIL CONT. ON BOTH SECTIONS OVER MATE WALL. USE APPLICABLE BEAM OVER OPEN SPANS (TYP.) PER PG'S C-10-10 OF SYSTEM DOCUMENT.
 - 17 RIDGE VENT TYP. 50% VENTILATION OF ROOF CAVITY (UPPER PORTION), INSTALLED PER CODE REQUIREMENTS.
 - 18 TYPICAL SHINGLES, INSTALLED PER MFGR'S INSTRUCTIONS.
 - 19 SHINGLE UNDERLAYMENT TYP.
 - 20 JOIST HANGERS AT MATELINE(S).
 - 21 1" MIN. SPACE FOR ATTIC VENTILATION.
 - 22 TYPICAL ICE BARRIER PER SECTION 905 OF APPLICABLE CODE.
 - 23 CEILING INSULATION TYP. (SEE INSULATION R-VALUES).
 - 24 ALUM., VINYL OR HARDIE BOARD FACIA AND DRIP EDGE.
 - 25 FLOOR CAVITY OR PERIMETER WALL MUST BE INSULATED ON SITE OR AT THE FACTORY (SEE "INSULATION R-VALUES")
 - 26 PERIMETER RIM JOIST MUST BE INSULATED TO R-VALUE LISTED FOR EXTERIOR WALLS
 - 27 INSULATION INSTALLED ONSITE BY OTHERS PER THERMAL REQUIREMENTS AND/OR STATE AND LOCAL CODES
 - 28 VENTED SOFFIT 50% OF LOWER ROOF VENTILATION.
 - 29 BAFFLE REQUIRED
 - 30 DRIFT BLOCKER
 - 31 FLOOR DECKING RATED FOR 19.2" O.C. JOIST SPACING MAX.
 - 32 MIN. 2X10 #2 SPF FLOOR JOIST 16" O.C.
 - 33 2X6 #3 SPF DOUBLE TOP PLATE.
 - 34 WALL COVERING (MIN. 1/2" GYPSUM).

Truss Data			
Truss #	Spacing	Sidewall	Centerline
R28R5F2	24	711	538
.	.	.	.
.	.	.	.

STUD O.C. SPACING
 EXTERIOR WALL: 16"
 INTERIOR WALL: 24"

SYSTEMS MANUAL REFERENCES
 FLOOR CONSTRUCTION: A-10-10 & 20
 SIDEWALL CONSTRUCTION: B-10-10
 CENTER WALL UPLIFT DETAIL: B-20-10
 COLUMN REQUIREMENTS: B-20-20, 21 & 30
 INTERIOR WALLS: B-30-10 & 11
 BEAMS: C-10-10 THRU C-10-30

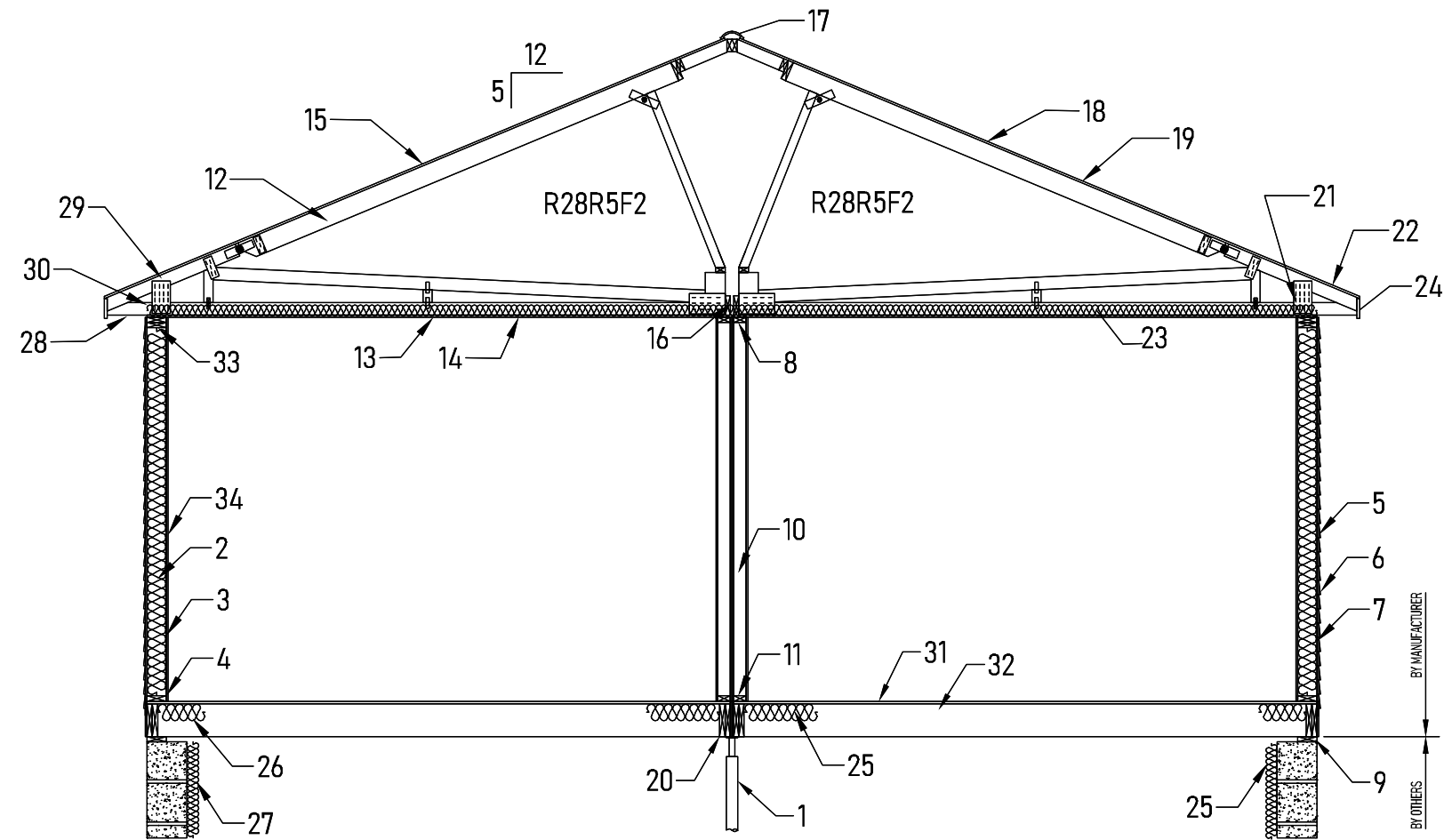

INSULATION R-VALUES
 CEILING: 38
 CEILING (Between Knee Walls: 0
 EXTERIOR WALLS (continuous): .
 EXTERIOR WALLS (cavity): 21
 FLOOR: 0
 FOUNDATION WALLS (continuous): 19
 FOUNDATION WALLS (cavity): 0

NOTES:
 FOLLOW RECOMMENDED ATTACHMENTS FOR FASTENING OF HOME TO FOUNDATION.
 FOUNDATIONS TO BE BUILT AND CONSTRUCTED BY OTHERS ON SITE.
 FOUNDATIONS (BY OTHERS) MUST MEET ALL APPLICABLE CODES.
 NOTES AND/OR ILLUSTRATIONS SHOWN ARE TYPICAL AND MAY NOT APPLY TO ALL HOMES CONSTRUCTED.
 CONSTRUCTION & SPECIFICATIONS MAY VARY PER PLAN.
 REFER TO INSTALLATION MANUAL FOR MODULE CONNECTIONS.
 REFER TO INSTALLATION MANUAL AND TRUSS MFG. DIAGRAM FOR ROOF TRUSS BRACING.

IMPORTANT!
 MAIN LEVEL FLOORS, OVER ENCLOSED FOUNDATIONS, CONSTRUCTED WITH OPTIONAL ENGINEERED WEB FLOOR JOISTS (OPEN JOISTS) OR WITH JOISTS OF NOMINAL LUMBER LESS THAN 2X10, MAY BE SUBJECT TO SPECIAL FIRE PROTECTIVE REQUIREMENTS TO BE PERFORMED BY OTHERS ON SITE. CONSULT ADOPTED LOCAL CODES FOR COMPLIANCE WITH FIRE PROTECTION OF FLOORS.

REFERENCE THE APPROVED SYSTEMS PACKAGE FOR ADDITIONAL AND SPECIFIC CROSS SECTION INFORMATION

TRIMLINE RIDGE VENT: ALLOWS 13" OF NET FREE AIR PER LINEAL FOOT
 FULL LENGTH OF HOUSE AIR FLO SOFFIT: FULL VENTED 5.89 SQ IN PER LINEAL FOOT
 FULL LENGTH OF HOUSE 2077/300 = 6.92 VENT REQUIRED

APPROVED BY

 12/7/2022
 Approval of this document does not authorize or approve any deviation or deviations from the requirements of applicable State Laws.
 Roger Colson

Builder: R-Anell Housing Group, LLC - Subsidiary of The Commodore Corp.	Callout: 2876	Revisions:	Scale: 1/4" = 1'-0"	Date: 11/30/2022	Cust: HILL
Title: Cross Section		Drawn By: NE	Reference: NONE		Dlr: CUSTOM BUILT
					S/N: 43906

Model/Eng. No.:
1B1503-R36
 XS

- NOTE:
- 3/4" GALVANIZED, OR COPPER RELIEF DRAIN (NOT SHOWN) THRU FLOOR w/VISIBLE AIR GAP
 - INLET WITH 1" CAP & CHAIN.
 - DIMENSIONS EXPRESSED IN PARENTHESIS (A x B) INDICATE: (DIST. FROM REAR END OF HOME FLOOR x DIST. FROM HOME MATE LINE).
 - ANTI-SCALD DEVICE ON ALL SHOWER, AND TUB/SHOWER COMBINATIONS.
 - WATER-HAMMER ARRESTORS AT BATTERY OF FIXTURES INSTALLED WHEREVER THERE IS A QUICK-CLOSING VALVE CONFORMING TO ASSE 1010 & MANUFACTURER'S INSTRUCTIONS.
 - SHUT-OFF VALVE IS REQUIRED AT EACH FIXTURE
 - BATHROOMS WITH DOUBLE LAVS ARE FED FROM THE SAME RISER.
 - ANY LINE NOT LABELED IS 1/2"
 - WATER HEATER TEMPERATURE & PRESSURE RELIEF VALVE AND RELIEF DRAIN PIPE INSTALLED PER MANUFACTURER'S SPECIFICATIONS.
 - SHUT-OFF VALVE AT WATER HEATER IS FULL OPEN VALVE INSTALLED ON COLD WATER SUPPLY PIPE AT EACH WATER HEATER, PER CODE.
 - FULLWAY SHUT-OFF VALVE WITH BLEED ORIFICE INSTALLED AT MAIN INLET SERVICE VALVE, INSTALLED ON-SITE, PER CODE.
 - SEE SYSTEMS PACKAGE PLUMBING SECTION PAGES FOR ADDITIONAL PLUMBING NOTES AND DETAILS

SITE NOTES FOR DIAGRAM EXPLANATION:

- WHEN VERTICAL FIXTURE WATER SUPPLY RISERS ONLY ARE SHOWN ON THIS PLAN, RISERS ONLY ARE FACTORY INSTALLED AS SHOWN AND TERMINATED BELOW THE FLOOR AT THE INDICATED LOCATIONS. MATERIAL PROVISIONS, SYSTEM CONNECTIONS, TESTING, AND INSPECTION FOR ALL BELOW-FLOOR CONNECTIONS ARE ON SITE BY OTHERS IN ACCORDANCE WITH ALL STATE AND LOCAL CODES.
- WHEN BELOW-FLOOR SYSTEM CONNECTIONS TO RISERS ARE SHOWN ON PLAN BY SOLID LINES, THESE ARE COMPLETED, TESTED, AND INSPECTED IN THE FACTORY TO THE TERMINATION POINT SHOWN ON ILLUSTRATED PLAN.
- DOTTED LINES ON PLAN, (IF PRESENT), ARE INTENDED ONLY TO ILLUSTRATE TYPICAL ON-SITE CONNECTIONS. THESE ARE FOR ILLUSTRATION ONLY AND ARE NOT PROVIDED, INSTALLED, TESTED, OR INSPECTED BY THE FACTORY.
- ALL BELOW FLOOR WATER LINES MUST BE SIZED, INSTALLED, AND TESTED ON SITE PER APPLICABLE LOCAL AND STATE CODES.

- ELECTRIC WATER HEATER-RHEEM MODEL #82V40-2
- ELECTRIC WATER HEATER-RHEEM MODEL #82V52-2
- ELECTRIC WATER HEATER-RHEEM MODEL #83VR52-2
- GAS WATER HEATER-RHEEM MODEL #22V40F1
- GAS WATER HEATER-RHEEM MODEL #22V50F1

LINE SIZED FOR DISHWASHER

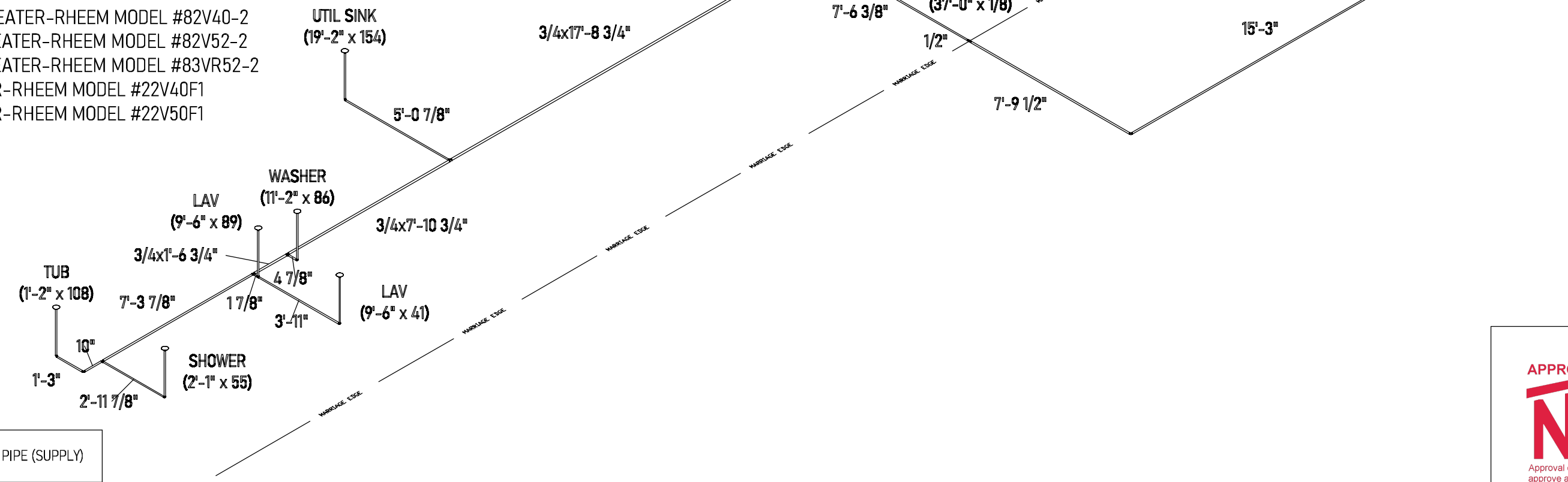

HANGER SPACING - PEX PIPE (SUPPLY)	
MAX HORIZONTAL SPACING (FT.)	MAX VERTICAL SPACING (FT.)
2'-8"	4'-0"

ALL DIMENSIONS FROM REAR AND MARRIAGE EDGE



Builder: R-Anell Housing Group, LLC - Subsidiary of The Commodore Corp.	Callout: 2876	Revisions:	Scale: CUSTOM	Date: 11/30/2022	Cust: HILL
Title: Hot Water Lines	Drawn By: NE	Reference: NONE	Dir: CUSTOM BUILT		S/N: 43906
					Model/Eng. No.: 1B1503-R36
					WH

- NOTE:
- 3/4" GALVANIZED, OR COPPER RELIEF DRAIN (NOT SHOWN) THRU FLOOR w/VISIBLE AIR GAP
 - INLET WITH 1" CAP & CHAIN.
 - DIMENSIONS EXPRESSED IN PARENTHESIS (A x B) INDICATE: (DIST. FROM REAR END OF HOME FLOOR x DIST. FROM HOME MATE LINE).
 - ANTI-SCALD DEVICE ON ALL SHOWER, AND TUB/SHOWER COMBINATIONS.
 - WATER-HAMMER ARRESTORS AT BATTERY OF FIXTURES INSTALLED WHEREVER THERE IS A QUICK-CLOSING VALVE CONFORMING TO ASSE 1010 & MANUFACTURER'S INSTRUCTIONS.
 - SHUT-OFF VALVE IS REQUIRED AT EACH FIXTURE
 - BATHROOMS WITH DOUBLE LAVS ARE FED FROM THE SAME RISER.
 - ANY LINE NOT LABELED IS 1/2"
 - WATER HEATER TEMPERATURE & PRESSURE RELIEF VALVE AND RELIEF DRAIN PIPE INSTALLED PER MANUFACTURER'S SPECIFICATIONS.
 - SHUT-OFF VALVE AT WATER HEATER IS FULL OPEN VALVE INSTALLED ON COLD WATER SUPPLY PIPE AT EACH WATER HEATER, PER CODE.
 - FULLWAY SHUT-OFF VALVE WITH BLEED ORIFICE INSTALLED AT MAIN INLET SERVICE VALVE, INSTALLED ON-SITE, PER CODE.
 - SEE SYSTEMS PACKAGE PLUMBING SECTION PAGES FOR ADDITIONAL PLUMBING NOTES AND DETAILS

- SITE NOTES FOR DIAGRAM EXPLANATION:
- WHEN VERTICAL FIXTURE WATER SUPPLY RISERS ONLY ARE SHOWN ON THIS PLAN, RISERS ONLY ARE FACTORY INSTALLED AS SHOWN AND TERMINATED BELOW THE FLOOR AT THE INDICATED LOCATIONS. MATERIAL PROVISIONS, SYSTEM CONNECTIONS, TESTING, AND INSPECTION FOR ALL BELOW-FLOOR CONNECTIONS ARE ON SITE BY OTHERS IN ACCORDANCE WITH ALL STATE AND LOCAL CODES.
 - WHEN BELOW-FLOOR SYSTEM CONNECTIONS TO RISERS ARE SHOWN ON PLAN BY SOLID LINES, THESE ARE COMPLETED, TESTED, AND INSPECTED IN THE FACTORY TO THE TERMINATION POINT SHOWN ON ILLUSTRATED PLAN.
 - DOTTED LINES ON PLAN, (IF PRESENT), ARE INTENDED ONLY TO ILLUSTRATE TYPICAL ON-SITE CONNECTIONS. THESE ARE FOR ILLUSTRATION ONLY AND ARE NOT PROVIDED, INSTALLED, TESTED, OR INSPECTED BY THE FACTORY.
 - ALL BELOW FLOOR WATER LINES MUST BE SIZED, INSTALLED, AND TESTED ON SITE PER APPLICABLE LOCAL AND STATE CODES.

ELECTRIC WATER HEATER-RHEEM MODEL #82V40-2
 ELECTRIC WATER HEATER-RHEEM MODEL #82V52-2
 ELECTRIC WATER HEATER-RHEEM MODEL #83VR52-2
 GAS WATER HEATER-RHEEM MODEL #22V40F1
 GAS WATER HEATER-RHEEM MODEL #22V50F1

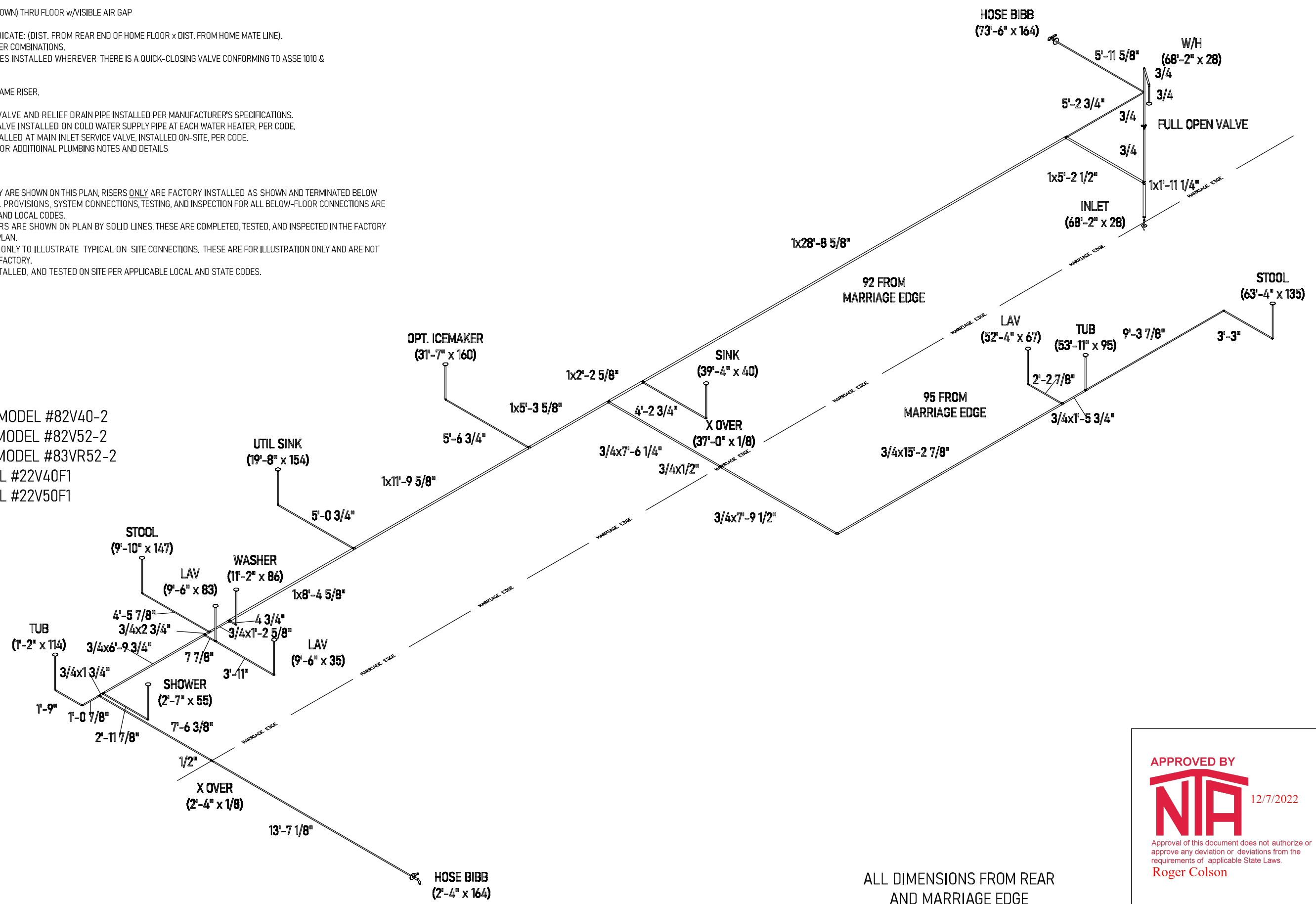

HANGER SPACING - PEX PIPE (SUPPLY)	
MAX HORIZONTAL SPACING (FT.)	MAX VERTICAL SPACING (FT.)
2'-8"	4'-0"

ALL DIMENSIONS FROM REAR AND MARRIAGE EDGE

APPROVED BY

 12/7/2022
 Approval of this document does not authorize or approve any deviation or deviations from the requirements of applicable State Laws.
 Roger Colson

Builder: R-Anell Housing Group, LLC - Subsidiary of The Commodore Corp.	Callout: 2876	Revisions:	Scale: CUSTOM	Date: 11/30/2022	Cust: HILL
Title: Cold Water Lines	Drawn By: NE	Reference: NONE	S/N: 43906	Dtr: CUSTOM BUILT	Model/Eng. No.: 1B1503-R36
					Pg.: WC

NOTE:

1. ALL LINES 1/4" SLOPE/FOOT MINIMUM UNLESS OTHERWISE NOTED.
2. ←○ DENOTES 1/8" SLOPE/FOOT.
3. ALL 2" DIA. LINES SHOWN FILLED (BOLD)
4. ALL LINES 1-1/2" DIA. MINIMUM OTHERWISE NOTED.
5. LINES SERVING STOOL ARE 3" DIA. CONTINUOUS TO OUTLET.
6. AIR ADMITTANCE VALVES SHOWN ARE IN ACCORDANCE w/ASSE 1051 & MANUFACTURER'S INSTRUCTIONS.
7. CONTINUOUS WASTE APPL. ON SINKS AND LAVATORIES WHERE SPACING DOES NOT EXCEED 30".
8. STACKS CLEANED THROUGH REMOVABLE FIXTURE P-TRAPS.
9. THE DISCHARGE LINE FROM THE DISHWASHER SHALL BE NOT LESS THAN 1/2 INCH NOMINAL SIZE AND SHALL EITHER BE LOOPED UP AND SECURELY FASTENED TO THE UNDERSIDE OF THE COUNTER OR BE CONNECTED TO A DECK-MOUNTED DISHWASHER AIR GAP FITTING THAT IS LISTED.

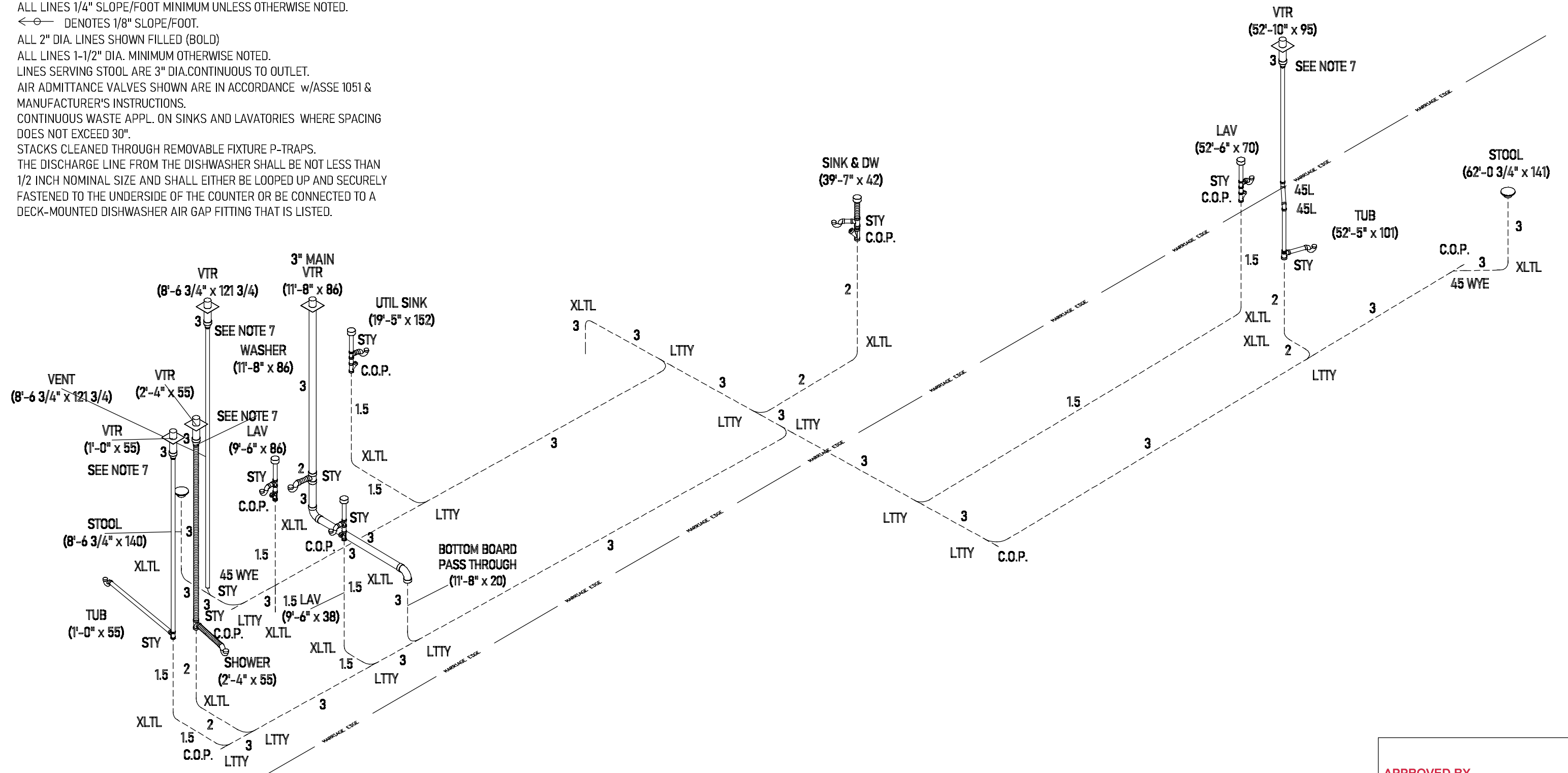

ALL DIMENSIONS FROM REAR AND MARRIAGE EDGE

HANGER SPACING - DRAIN PIPE (DWW)	
MAX HORIZONTAL SPACING (FT.)	VERTICAL SPACING
4'-0"	Vertical piping shall be supported at each story or floor level.

DWW FITTING IDENTIFICATION			
XLTL	LONG TURN 90° ELBOW	4X3CB	90° CLOSET ELBOW
XLSL	LONG TURN 90° STREET ELBOW	3-WAY-L	DOUBLE 90° ELBOW
45L	45° ELBOW	STY	SANITARY TEE
45SL	45° STREET ELBOW	LTTY	LONG RADIUS TY
22.5L	22 1/2° ELBOW	45 WYE	45° WYE
22.5SL	22 1/2° STREET ELBOW		

PLUMBING ABOVE THE FLOOR IS FACTORY INSTALLED. PLUMBING BELOW THE FLOOR INCLUDING CONNECTIONS SHALL BE INSTALLED ON SITE BY OTHERS ACCORDING TO SITE CONDITIONS, SUBJECT TO APPROVAL OF LOCAL INSPECTION. ON SITE PLUMBING SHOWN IS SUGGESTIVE ONLY.

APPROVED BY

 12/7/2022
 Approval of this document does not authorize or approve any deviation or deviations from the requirements of applicable State Laws.
 Roger Colson

Builder: R-Anell Housing Group, LLC - Subsidiary of The Commodore Corp.	Callout: 2876	Revisions:	Scale: CUSTOM	Date: 11/30/2022	Cust: HILL
Title: DWV System		Drawn By: NE	Reference: NONE		Dlr: CUSTOM BUILT
					S/N: 43906
					Pg: DL

PIPE SUPPORT:

VERTICAL PIPING:

SUPPORTS AT 10' O.C. MAX. OR BETWEEN FLOOR LEVELS.

HORIZONTAL PIPING:

SUPPORTS AT 4' O.C. MAX. ENDS OF BRANCHES, AND AT CHANGES IN ELEVATION AND/OR DIRECTION.

TRAP ARMS:

SUPPORT LOCATED AS CLOSE TO TRAP AS POSSIBLE WHEN TRAP TO VENT EXCEEDS 3'.

WATER HEATERS, WHICH HAVE A "BACK-FLOW PREVENTER" OR A "CHECK VALVE" LOCATED IN THE COLD WATER INLET LINE, ARE TO BE EQUIPPED WITH AN EXPANSION TANK INSTALLED BETWEEN THE BACK-FLOW PREVENTER (OR CHECK VALVE) AND THE WATER HEATER IN ORDER TO ALIEVIATE THERMAL EXPANSION.

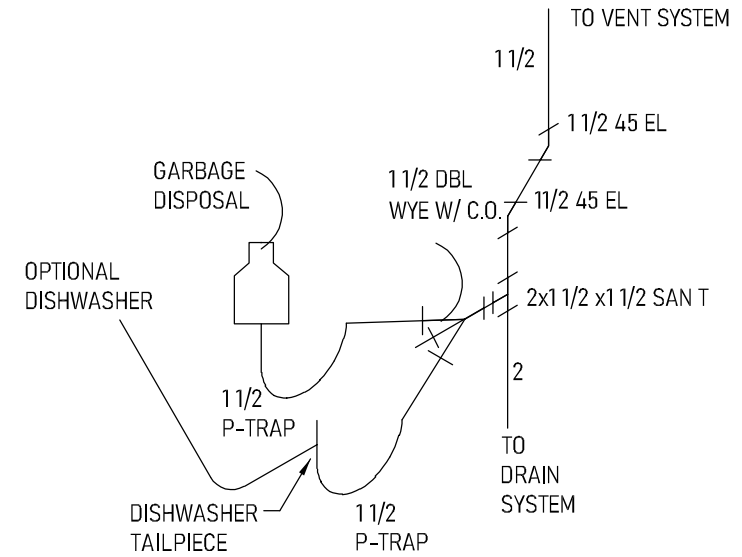
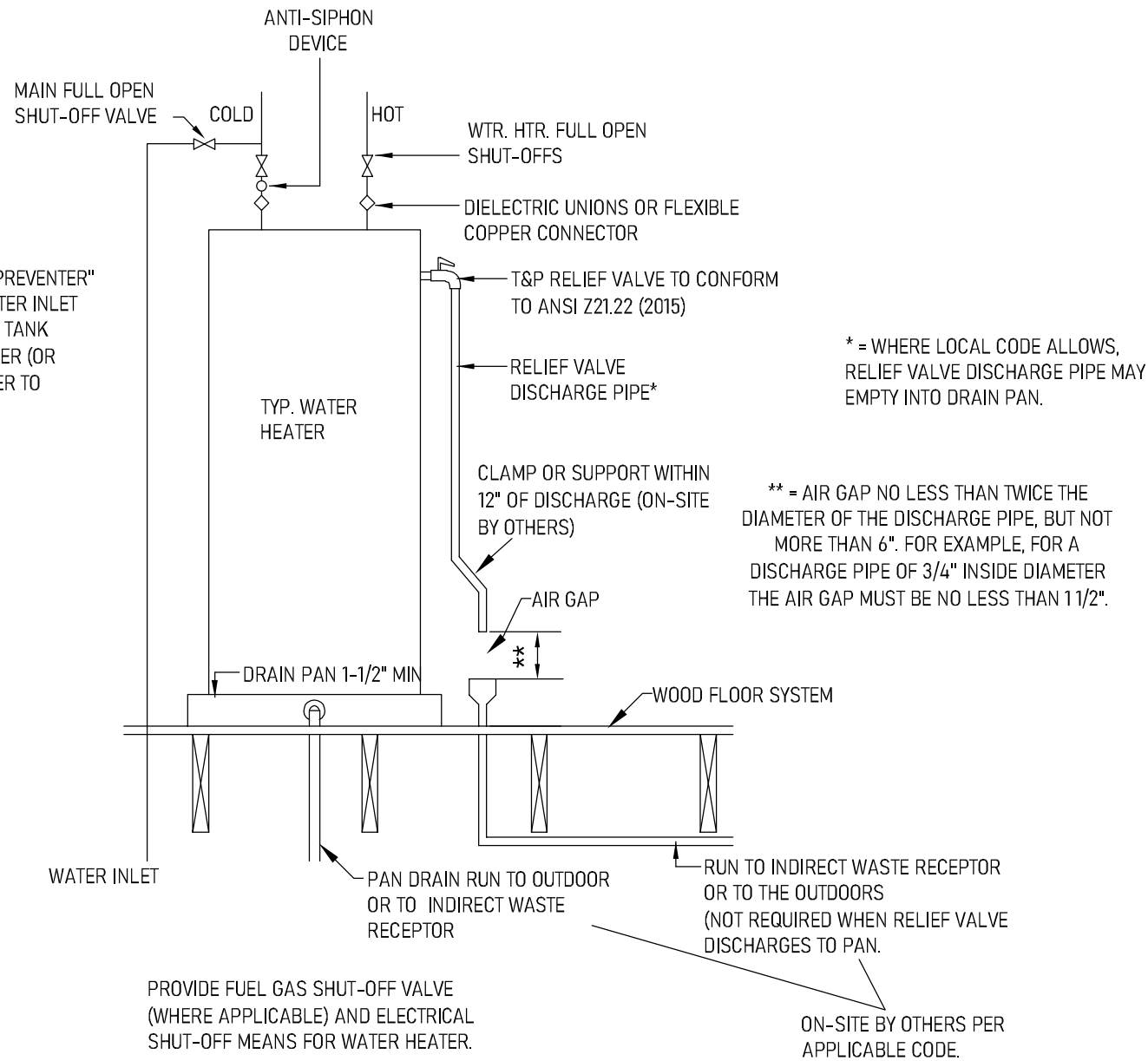

OPTIONAL GARBAGE DISPOSAL PLUMBING ILLINOIS MODELS ONLY - USE DETAIL ABOVE FOR OPTIONAL GARBAGE DISPOSAL.

- NOTES:**
- ALL BELOW FLOOR PLUMBING BY OTHERS. ALL FITTINGS BELOW BOTTOM CAN BE SHIPPED LOOSE.
 - ALL BELOW FLOOR PLUMBING ILLUSTRATIONS ARE RECOMMENDATIONS ONLY. ON-SITE CONDITIONS AND/OR RESTRICTIONS MAY REQUIRE SOME MODIFICATIONS.
 - OPT. GARBAGE DISPOSAL TO BE LOCATED ON KITCHEN SINK WASTE ASSEMBLY. ALL VENTS THRU ROOF TO BE 3", 12" MIN. ABOVE AND BELOW ROOF PENETRATION.
 - ALL P-TRAPS TO BE 1 1/2" UNLESS NOTED.
 - HORIZONTAL VENT SLOPE : 1/8" PER FOOT
 - HORIZONTAL DRAIN SLOPE: 1/4" PER FOOT
 - DRAIN, WASTE, AND VENT PLUMBING TO BE PVC PLASTIC OR EQUAL, APPROVED FOR DWV APPLICATIONS.
 - DRAIN AND DISCHARGE PIPES SERVING WATER HEATERS TO BE CPVC OR OTHER CODE APPROVED MATERIAL.
 - ANY TRANSITIONS TO MATERIALS, OTHER THAN THE SPECIFIED MATERIAL, MUST INCORPORATE AN APPROVED FITTING FOR CONNECTION.
 - ALL TUBS WITH WHIRLPOOL MUST BE PROVIDED WITH ACCESS TO MOTOR. ALL PLUMBING TO MEET OR EXCEED CURRENT ADOPTED PLUMBING CODES.
 - IN CONCEALED SPACES WHERE PIPING IS INSTALLED THRU HOLES OR NOTCHES IN STUDS, JOISTS, TRUSSES, OR SIMILAR MEMBERS LESS THAN 1 1/2" FROM NEAREST EDGE OF THE MEMBER, THE PIPE SHALL BE PROTECTED BY SHIELD PLATES.
 - PROTECTIVE SHIELD PLATES SHALL BE A MINIMUM OF 16 GA. STEEL. PLATES SHALL COVER AREA OF THE PIPE WHERE THE MEMBERS ARE NOTCHED OR BORED, AND SHALL EXTEND A MINIMUM OF 2" ABOVE SOLE PLATES AND BELOW TOP PLATES.
 - AIR ADMITTANCE VALVES MAY SUBSTITUTE ROOF VENTS AT VARIOUS LOCATIONS PER APPLICABLE STATE AND LOCAL PLUMBING CODES. THE 3" MAIN VENT MUST BE VENTED THRU THE ROOF AND CANNOT BE MECHANICALLY VENTED.
 - IN SEISMIC CATEGORIES D0, D1, D2 OR E STRAP UPPER THIRD AND LOWER THIRD OF WATER HEATER TO RESIST A HORIZONTAL FORCE OF 1/3 THE OPERATING WEIGHT OF THE WATER HEATER.

APPROVED BY

 12/7/2022
 Approval of this document does not authorize or approve any deviation or deviations from the requirements of applicable State Laws.
Roger Colson

Builder: R-Anell Housing Group, LLC - Subsidiary of The Commodore Corp.	Callout: 2876	Revisions:	Scale: N.T.S.	Date: 11/30/2022	Cust: HILL
Title: DWV Notes		Drawn By: NE	Reference: NONE		Dlr: CUSTOM BUILT
					S/N: 43906

Model/Eng. No.:
1B1503-R36
 DN

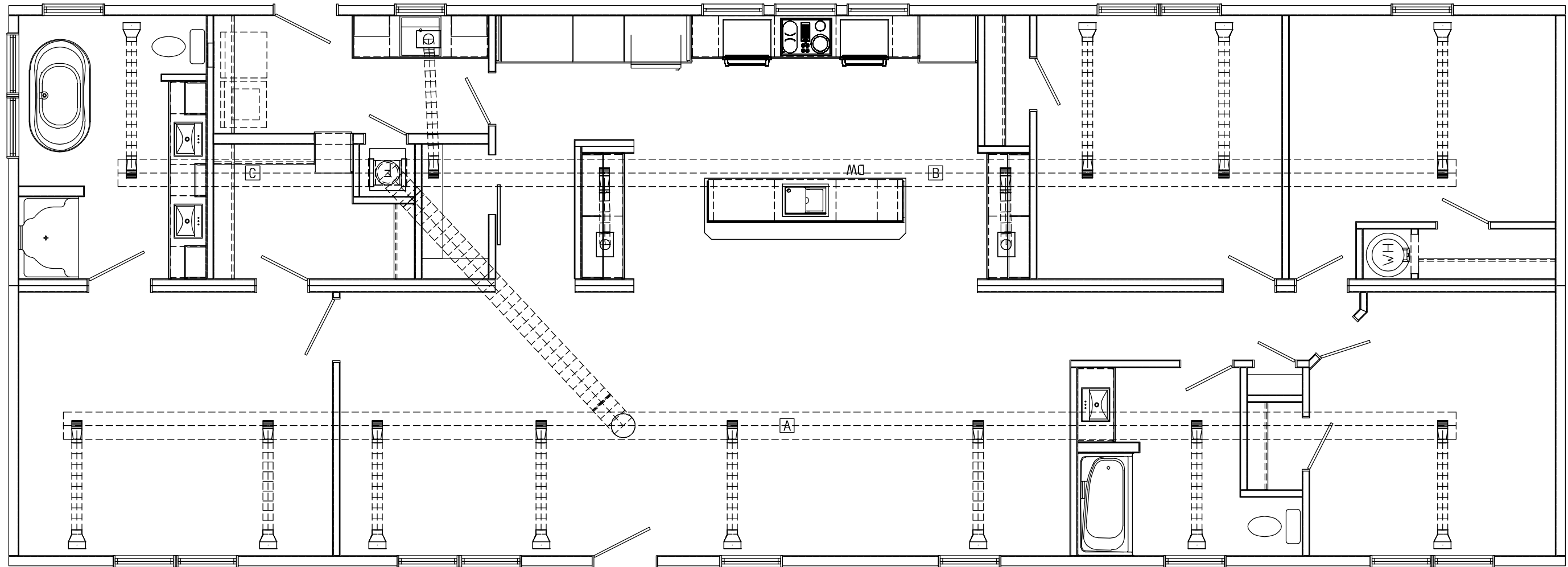

HVAC SCHEDULE			
LABEL	QTY	DESCRIPTION	LENGTH
A	1	DUCT - 7.5X16.13	68'-0"
B	1	DUCT - 7.5X16.13	51'-5 7/8"
C	1	DUCT - 7.5X16.13	12'-5 7/8"

APPROVED BY



12/7/2022

Approval of this document does not authorize or approve any deviation or deviations from the requirements of applicable State Laws.

Roger Colson

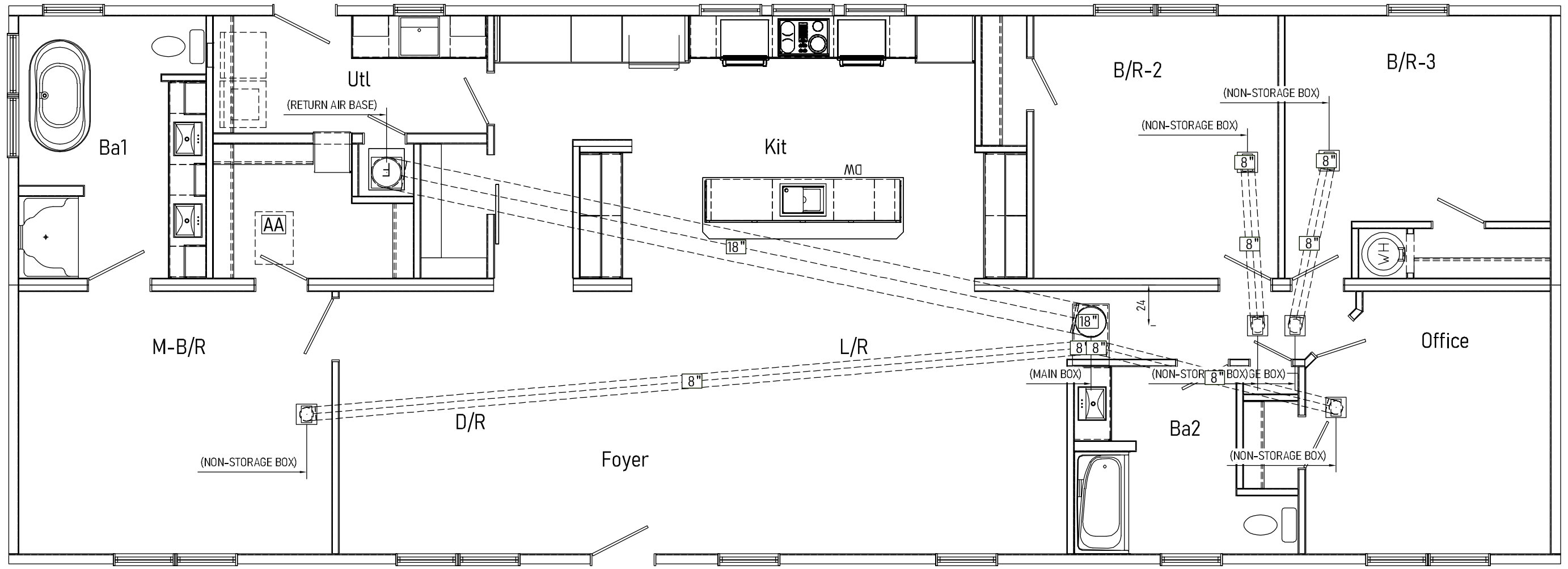

Return Air Material/Quantity List	
Main Box	1
Non-Storage Box (12x12x4)	6
10x6 Ceiling Grille	6
20x24 Ceiling Grille	1
8" Insulated Flex Duct	72'
18" Insulated Flex Duct	38'
6" Start Collar	1
8" Start Collar	6

RETURNS IN CEILING IN ADDITION TO AIR THRU GRILLES/OPENINGS

APPROVED BY

 12/7/2022
 Approval of this document does not authorize or approve any deviation or deviations from the requirements of applicable State Laws.
Roger Colson

VERTICAL BWL 1	
REQUIRED	9.69
PROVIDED	19.90
MEETS REQ	YES
% SHEATHED	77%

NCRC BRACED WALL CONSTRUCTION DETAILS	
WALL TYPE	CONSTRUCTION
EXTERIOR	7/16" SHEATHING ONE SIDE WITH 0.131 PD NAILS AT 6" O/C EDGE SPACING AND 12" O/C FIELD SPACING.

VERTICAL BWL 2	
REQUIRED	9.69
PROVIDED	27.33
MEETS REQ	YES
% SHEATHED	100%

HORIZONTAL BWL 1	
REQUIRED	3.77
PROVIDED	46.35
MEETS REQ	YES
% SHEATHED	64%

HORIZONTAL BWL 2	
REQUIRED	3.77
PROVIDED	45.42
MEETS REQ	YES
% SHEATHED	59%

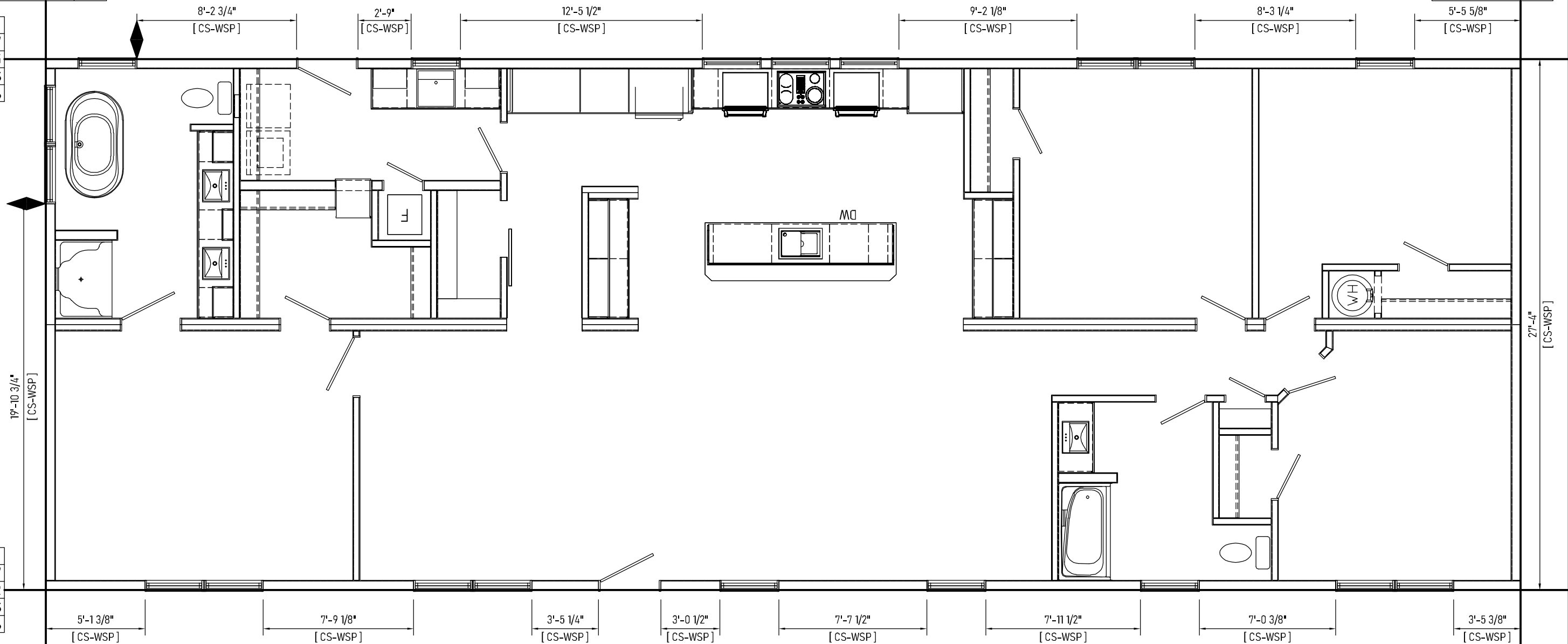

Braced Wall										
Unit	Method	Wind Load	Wind Load Method	Width	Length	Exposure	Roof Pitch	Sidewall Height	Seismic	Max. Mean Roof Height
MAIN	2018 NC RC	130 mph	Ultimate	27'-4"	76'-0"	B	5/12	9'-0"	C	IRC

◆ = Factory Installed Hold-Down Device with a Minimum Uplift Design Value of 800 LB.

Bracing per prescriptive North Carolina 2018 Residential code.

In conjunction with the wall bracing requirements of Section 602.10, all exterior walls are sheathed with wood structural sheathing panels in accordance with 4506.2 for 140 to 150 MPH structural bracing.

FOUNDATION TIE-DOWN MUST BE CONNECTED ON-SITE BY POINT LOAD LOCATIONS AS NOTED (BY OTHERS). ALTERNATIVE TIE DOWN CONNECTION METHODS APPROVED BY A LOCAL ENGINEER MAY BE USED. REFER TO THE IRC FOR FOUNDATION TIE DOWN REQUIREMENTS FOR 130 MPH OR LESS WIND ZONES

APPROVED BY



12/7/2022

Approval of this document does not authorize or approve any deviation or deviations from the requirements of applicable State Laws.

Roger Colson

Builder: R-Anell Housing Group, LLC - Subsidiary of The Commodore Corp.	Callout: 2876	Revisions:	Scale: 3/16" = 1'-0"	Date: 11/30/2022	Cust: HILL
Title: Braced Walls-Prescriptive		Drawn By: NE	Reference: NONE		Dlr: CUSTOM BUILT
					S/N: 43906

Model/Eng. No.: 1B1503-R36
BWP

Footing size (in.)	Footing max. load (lbs.) for 8" x16" pier		
	1500 PSF	2000 PSF	2500 PSF
*16x16x6	2.5K	3.4K	4.3K
*20x20x6	4.0K	5.3K	6.7K
24x24x8	5.6K	7.6K	9.6K
30x30x10	8.5K	11.7K	14.8K
36x36x12	12.4K	16.7K	20.7K
42x42x14	16.5K	22.4K	28.2K
48x48x14	21.2K	N/A	N/A

* = A 4" thick pre-cast footer of equivalent width and length may be used in place of a 6" thick cast in place footer.
 Footer size must be designed by others to site conditions if noted kip load exceeds capacities listed above

COLUMNS & FOOTINGS MUST BE RATED TO MEET THE CENTER LINE LOADS LISTED

GROUND SNOW LOAD
20 PSF

Kip loads noted are based on allowable stress design (ASD). Capacity of supports (columns, footings, etc.) must exceed noted Kip loads. Any changes to this plan that effect the foundation in any way will be the sole responsibility of the builder/dealer.

SELF-WEIGHT ON FOOTERS NOT INCLUDED IN LOADS SHOWN.
 ♦ IF APPLICABLE, REPRESENTS TIE DOWN LOADS FROM BRACE WALLS TO FOUNDATION. TO BE DESIGNED ON SITE BY OTHERS.

FOR CONNECTION OF THE HOME TO FOUNDATION AT BRACING WALLS, REFER TO "BRACED WALLS-CALCULATED" PAGE, IF APPLICABLE. WHEN THIS PAGE IS PRESENT, HORIZONTAL AND OVERTURNING (RACKING) LOADS AT BRACING WALL LOCATIONS ARE INDICATED FOR THESE FOUNDATION CONNECTIONS. THESE LOADS MAY BE RECALCULATED AND REDESIGNED PER LOCAL CODES TO CONFORM TO SITE CONDITIONS AS REQUIRED. REFER TO CHAPTER 3 (3.9 TIE DOWN TO FOUNDATION) OF THE "MODULAR HOME INSTALLATION MANUAL" FOR ADDITIONAL INFORMATION. REFER TO APPLICABLE CODES FOR CONNECTION OF HOME TO FOUNDATION WHEN "BRACED WALLS-PRESCRIPTIVE" PAGE IS APPLICABLE.

FOUNDATION SHOWN MUST BE DESIGNED BY OTHERS TO THE SITE CONDITIONS. THIS INCLUDES SEISMIC DESIGN AND ATTACHING THE HOME TO THE FOUNDATION, ALONG WITH RESISTANCE TO LATERAL, LONGITUDINAL SHEAR, UPLIFT AND DOWNLIFT FORCES IN BOTH DIRECTIONS.

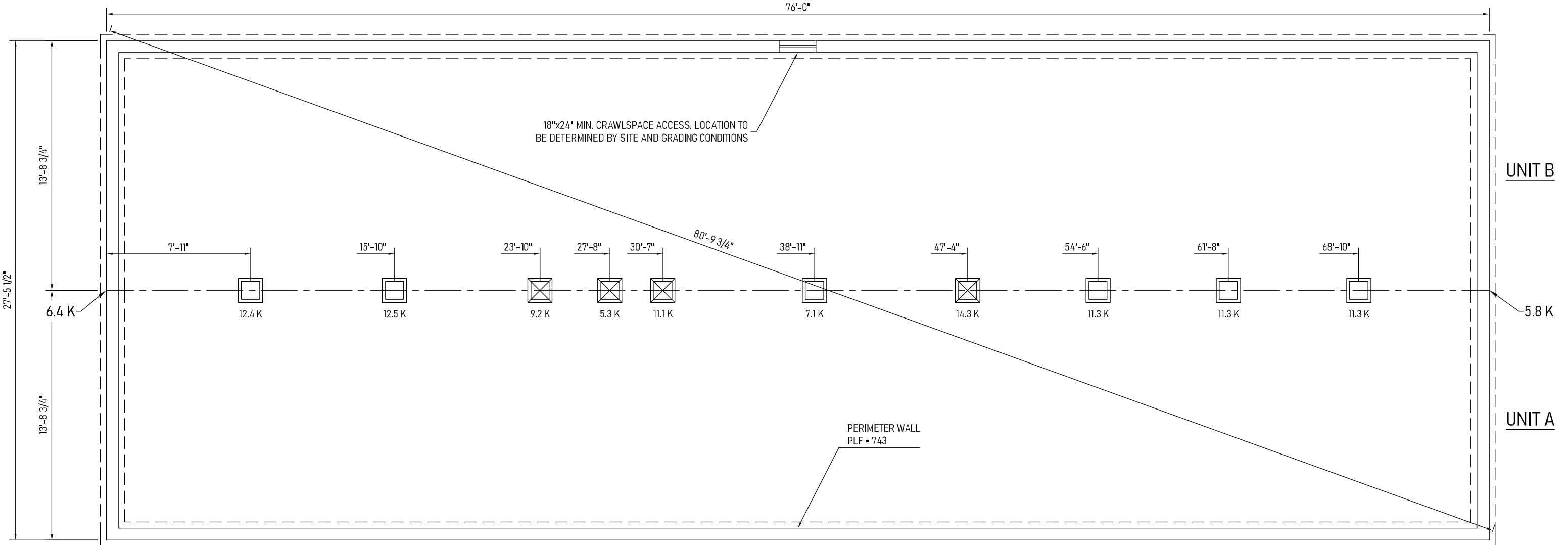

- 2X10 OR TRUSS FLOOR NOTES -
- FOUNDATION LAYOUT IS APPLICABLE TO NOTED MAXIMUM SNOW LOADING AND MINIMUM SOIL BEARING PRESSURE. REFER TO INSTALLATION MANUAL FOR OTHER APPLICABLE INFORMATION. CONSULT LOCAL OFFICIALS AND THE APPLICABLE LOCAL CODES FOR OTHER REQUIREMENTS (I.E. DRAINAGE, DAMP-PROOFING, BACKFILL SUPPORT, ETC.).
 - WIDTH DIMENSIONS SHOWN INCLUDE A 3/4" ALLOWANCE PER HOME SECTION FOR HOMES WITH FACTORY-INSTALLED O.S.B. ON THE MARRIAGE WALL MATE LINE. THIS ALLOWANCE TAKES INTO ACCOUNT THE 7/16" O.S.B. MATERIAL INSTALLED ON EACH MARRIAGE WALL PLUS ALLOWANCE DUE TO OTHER FACTORS. IF HOME DOES NOT INCLUDE O.S.B. ON THE MARRIAGE WALL MATE LINE, FOUNDATION WIDTH IS TO BE SIZED EQUAL TO ACTUAL MANUFACTURED FLOOR WIDTH. LESSER DIMENSION, IF SHOWN, INDICATES ACTUAL FLOOR WIDTH. THESE DIMENSIONS DO NOT ALLOW FOR ANY VARIANCE THAT MAY OCCUR IN SITE INSTALLATION SUCH AS GAPPING, OFF CENTER SET OR OTHER FIELD-ENCOUNTERED VARIABLES. ANY ADJUSTMENTS NEEDED IN FOUNDATION WIDTH DUE TO SUCH VARIANCES ARE AT THE DISCRETION OF THE INSTALLER.
 - FOR DEVIATIONS &/OR OTHER FOUNDATION DESIGNS CONSULT A LOCAL PROFESSIONAL ENGINEER & YOUR LOCAL BUILDING OFFICIAL.
 - SILL PLATE FASTENING TO BE PER INSTALLATION MANUAL AND/OR LOCAL CODES. SILL FASTENING REQUIREMENT IS PER APPLICABLE WIND SPEED AND SEISMIC ZONES. SEE YOUR HOME DATA PLATE FOR APPLICABLE ZONES.
 - CONCRETE COMPRESSIVE STRENGTH (FC): 2500 PSI MINIMUM.
 - CENTERLINE LINE SUPPORTS AND SPACING ARE BASED ON (2) 2X10'S SPF#2 ON EACH HALF (4-2X10'S TOTAL).
 - CRAWLSPACE VENTILATION IS NOT REQUIRED WHEN INSULATION IS APPLIED TO CRAWLSPACE WALLS AS REQUIRED BY RESCHECK (CONDITIONED AIR). INSTALLATION OF VENTS IN CRAWLSPACE WALLS WOULD MANDATE INSULATING THE FLOOR SYSTEM PER APPLICABLE THERMAL CALCULATIONS. REFER TO APPLICABLE PRESCRIPTIVE CODES & GUIDELINES. WHEN REQUIRED, ONE VENT SHALL BE PROVIDED WITHIN 3 FEET OF EACH CORNER.
 - FOUNDATION CONSTRUCTION AND TIE DOWN REQUIREMENTS FOR HOMES LOCATED IN 90 MPH OR LESS WIND ZONES MAY USE APPLICABLE PRESCRIPTIVE CODES & GUIDELINES UNLESS NOTED OTHERWISE.

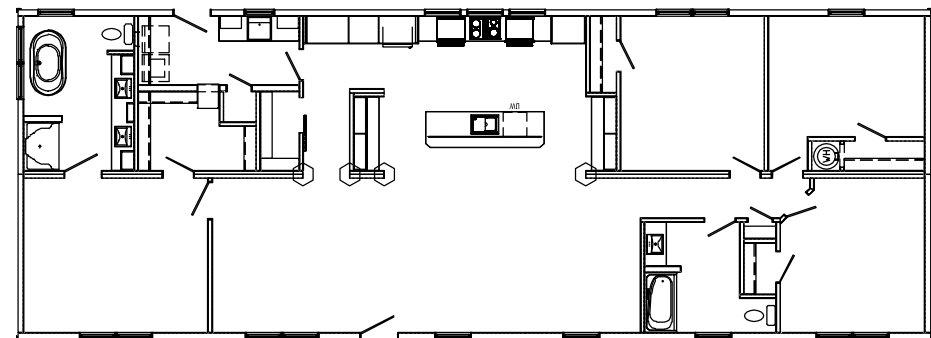

APPROVED BY

 12/7/2022
 Approval of this document does not authorize or approve any deviation or deviations from the requirements of applicable State Laws.
Roger Colson

Builder: R-Anell Housing Group, LLC - Subsidiary of The Commodore Corp.	Callout: 2876	Revisions:	Scale: 3/16" = 1'-0"	Date: 11/30/2022	Cust: HILL
Title: Foundation 2x10 Marriage Line without Stair	Drawn By: NE	Reference: NONE	Dtr: CUSTOM BUILT	S/N: 43906	Model/Eng. No.: 1B1503-R36
					Pg.: FD20#

3933 E. Jackson Blvd., Elkhart, IN 46516 Phone: 574-293-5526 Fax: 574-294-1366 Email: eng-ams@comcast.net

APPROVED BY



12/7/2022

Project Information

For: The Commodore Corporation
 1B1503-R36

Approval of this document does not authorize or approve any deviation or deviations from the requirements of applicable State Laws.
Roger Colson

Design Information

	Htg	Clg	Infiltration	
Outside db (°F)	17	100	Method	Simplified
Inside db (°F)	70	75	Construction quality	Average
Design TD (°F)	53	25	Fireplaces	0
Daily range	-	M		
Inside humidity (%)	50	50		
Moisture difference (gr/lb)	45	48		

HEATING EQUIPMENT

Make	Generic
Trade	
Model	AFUE 100
AHRI ref	
Efficiency	100 AFUE
Heating input	8.1 kW
Heating output	27746 Btuh
Temperature rise	27 °F
Actual air flow	938 cfm
Air flow factor	0.042 cfm/Btuh
Static pressure	0.50 in H2O
Space thermostat	

COOLING EQUIPMENT

Make	Generic
Trade	
Cond	SEER 14.0
Coil	
AHRI ref	
Efficiency	12.2 EER, 14 SEER
Sensible cooling	23544 Btuh
Latent cooling	10090 Btuh
Total cooling	33634 Btuh
Actual air flow	938 cfm
Air flow factor	0.047 cfm/Btuh
Static pressure	0.50 in H2O
Load sensible heat ratio	0.78

ROOM NAME	Area (ft²)	Htg load (Btuh)	Clg load (Btuh)	Htg AVF (cfm)	Clg AVF (cfm)
BA1	135	1898	1516	80	72
WIC	62	0	0	0	0
UTL	97	1399	1077	59	51
PAN	27	0	0	0	0
KIT	338	2393	4351	101	207
B2	182	1487	2210	63	105
B3	186	1937	1695	81	81
B1	220	2369	2424	100	115
STAIR	52	0	0	0	0
D/R-L/R	443	3794	4023	160	191
BA2	102	1015	956	43	45
H	44	0	0	0	0
OFFICE	168	1860	1495	78	71
CRAWL	2071	4148	0	174	0

Calculations approved by ACCA to meet all requirements of Manual J 8th Ed.

CL	16	0	0	0	
Entire House	4142	22299	19747	938	938
Other equip loads		5447	2591		
Equip. @ 1.05 RSM			23544		
Latent cooling			6242		
TOTALS	4142	27746	29786	938	938

APPROVED BY
 12/7/2022
 Approval of this document does not authorize or approve any deviation or deviations from the requirements of applicable State Laws.
Roger Colson

Calculations approved by ACCA to meet all requirements of Manual J 8th Ed.

Project Information

For: The Commodore Corporation
 1B1503-R36

Notes:

APPROVED BY



12/7/2022

Approval of this document does not authorize or approve any deviation or deviations from the requirements of applicable State Laws.

Roger Colson

Design Information

Weather: Harnett Regional, NC, US

Winter Design Conditions

Outside db	17 °F
Inside db	70 °F
Design TD	53 °F

Summer Design Conditions

Outside db	100 °F
Inside db	75 °F
Design TD	25 °F
Daily range	M
Relative humidity	50 %
Moisture difference	48 gr/lb

Heating Summary

Structure	23037 Btuh
Ducts	-738 Btuh
Central vent (93 cfm)	5447 Btuh
Outside air	
Humidification	0 Btuh
Piping	0 Btuh
Equipment load	27746 Btuh

Sensible Cooling Equipment Load Sizing

Structure	20487 Btuh
Ducts	-741 Btuh
Central vent (93 cfm)	2591 Btuh
Outside air	
Blower	0 Btuh
Use manufacturer's data	n
Rate/swing multiplier	1.05
Equipment sensible load	23544 Btuh

Infiltration

Method	Simplified
Construction quality	Average
Fireplaces	0

Latent Cooling Equipment Load Sizing

Structure	2905 Btuh
Ducts	322 Btuh
Central vent (93 cfm)	3016 Btuh
Outside air	
Equipment latent load	6242 Btuh

	Heating	Cooling
Area (ft ²)	4142	4142
Volume (ft ³)	18639	18639
Air changes/hour	0.28	0.15
Equiv. AVF (cfm)	87	47

Equipment Total Load (Sen+Lat)	29786 Btuh
Req. total capacity at 0.70 SHR	2.8 ton

Heating Equipment Summary

Make	Generic
Trade	
Model	AFUE 100
AHRI ref	
Efficiency	100 AFUE
Heating input	8.1 kW
Heating output	27746 Btuh
Temperature rise	27 °F
Actual air flow	938 cfm
Air flow factor	0.042 cfm/Btuh
Static pressure	0.50 in H2O
Space thermostat	

Cooling Equipment Summary

Make	Generic
Trade	
Cond	SEER 14.0
Coil	
AHRI ref	
Efficiency	12.2 EER, 14 SEER
Sensible cooling	23544 Btuh
Latent cooling	10090 Btuh
Total cooling	33634 Btuh
Actual air flow	938 cfm
Air flow factor	0.047 cfm/Btuh
Static pressure	0.50 in H2O
Load sensible heat ratio	0.78

Calculations approved by ACCA to meet all requirements of Manual J 8th Ed.

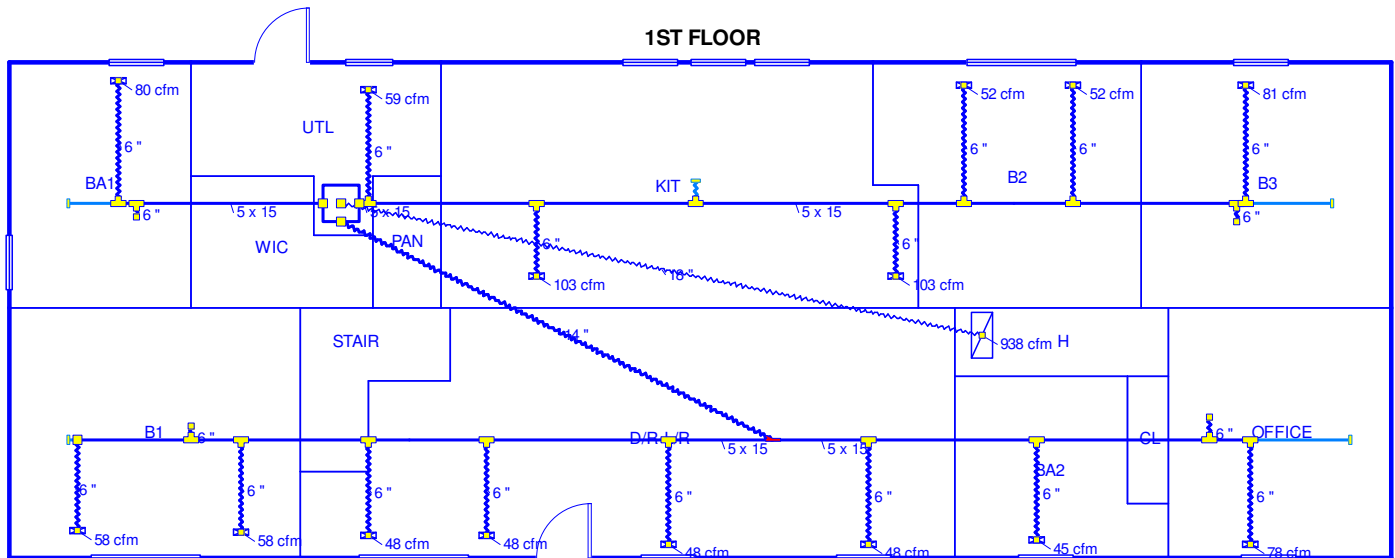
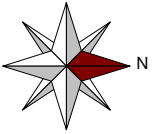

APPROVED BY

NIA 12/7/2022

Approval of this document does not authorize or approve any deviation or deviations from the requirements of applicable State Laws.

Roger Colson

Job #: 1B1503-R36
Performed by AMS of Indiana, Inc. for:
 The Commodore Corporation
 1B1503-R36

AMS of Indiana, Inc.
 3933 E. Jackson Blvd.
 Elkhart, IN 46516
 Phone: 574-293-5526 Fax: 574-294-1366
 eng-ams@comcast.net

Scale: 1 : 127
 Page 1
 Right-Suite@ Universal 2022
 22.0.01 RSU02009
 2022-Dec-06 14:55:51
 F:\DS\Commodore\1B1503-R36(NC...

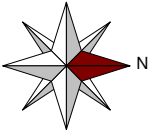

CRAWL



APPROVED BY



12/7/2022

Approval of this document does not authorize or approve any deviation or deviations from the requirements of applicable State Laws.

Roger Colson

Job #: 1B1503-R36
Performed by AMS of Indiana, Inc. for:
 The Commodore Corporation
 1B1503-R36

AMS of Indiana, Inc.
 3933 E. Jackson Blvd.
 Elkhart, IN 46516
 Phone: 574-293-5526 Fax: 574-294-1366
 eng-ams@comcast.net

Scale: 1 : 127
 Page 2
 Right-Suite@ Universal 2022
 22.0.01 RSU02009
 2022-Dec-06 14:55:51
 F:\DS\Commodore\1B1503-R36(NC...

Project Information

For: The Commodore Corporation
 1B1503-R36

	Heating	Cooling
External static pressure	0.50 in H2O	0.50 in H2O
Pressure losses	0.26 in H2O	0.26 in H2O
Available static pressure	0.24 in H2O	0.24 in H2O
Supply / return available pressure	0.179 / 0.061 in H2O	0.179 / 0.061 in H2O
Lowest friction rate	0.064 in/100ft	0.064 in/100ft
Actual air flow	938 cfm	938 cfm
Total effective length (TEL)	375 ft	

Supply Branch Detail Table

Name	Design (Btuh)	Htg (cfm)	Clg (cfm)	Design FR	Diam (in)	H x W (in)	Duct Matl	Actual Ln (ft)	Ftg.Eqv Ln (ft)	Trunk	
B1	c	1212	50	58	0.067	6.0	0x0	VIFx	69.9	195.0	st6
B1-A	c	1212	50	58	0.065	6.0	0x0	VIFx	60.9	215.0	st6
B2	c	1105	31	52	0.089	6.0	0x0	VIFx	39.8	160.0	st4
B2-A	c	1105	31	52	0.091	6.0	0x0	VIFx	45.8	150.0	st4
B3	h	1937	81	81	0.096	6.0	0x0	VIFx	55.3	130.0	st4
BA1	h	1898	80	72	0.121	6.0	0x0	VIFx	18.0	130.0	st3
BA2	c	956	43	45	0.068	6.0	0x0	VIFx	46.6	215.0	st7
CRAWL	h	1037	44	0	0.094	6.0	0x0	VIFx	49.3	140.0	st4
CRAWL-B	h	1037	44	0	0.068	6.0	0x0	VIFx	59.4	205.0	st6
CRAWL-C	h	1037	44	0	0.118	6.0	0x0	VIFx	11.0	140.0	st3
CRAWL-D	h	1037	44	0	0.070	6.0	0x0	VIFx	51.9	205.0	st7
D/R-L/R	c	1006	40	48	0.064	6.0	0x0	VIFx	38.1	240.0	st6
D/R-L/R-B	c	1006	40	48	0.068	6.0	0x0	VIFx	37.6	225.0	st7
D/R-L/R-C	c	1006	40	48	0.064	6.0	0x0	VIFx	54.1	225.0	st6
D/R-L/R-D	c	1006	40	48	0.064	6.0	0x0	VIFx	47.6	230.0	st6
KIT	c	2176	50	103	0.095	6.0	0x0	VIFx	13.8	175.0	st1
KIT-A	c	2176	50	103	0.090	6.0	0x0	VIFx	33.5	165.0	st4
OFFICE	h	1860	78	71	0.070	6.0	0x0	VIFx	58.6	195.0	st7
UTL	h	1399	59	51	0.098	6.0	0x0	VIFx	6.8	175.0	st1

APPROVED BY

12/7/2022

Approval of this document does not authorize or approve any deviation or deviations from the requirements of applicable State Laws.

Roger Colson

Supply Trunk Detail Table

Name	Trunk Type	Htg (cfm)	Clg (cfm)	Design FR	Veloc (fpm)	Diam (in)	H x W (in)	Duct Material	Trunk
st6	Peak AVF	263	258	0.064	505	9.6	15 x 5	RectFbg	st2
st4	Peak AVF	238	289	0.089	555	9.3	15 x 5	RectFbg	st1
st7	Peak AVF	204	164	0.068	393	8.7	15 x 5	RectFbg	st2
st1	Peak AVF	347	443	0.089	851	11.0	15 x 5	RectFbg	
st3	Peak AVF	123	72	0.118	237	6.4	15 x 5	RectFbg	
st2	Peak AVF	467	423	0.064	437	14.0	0 x 0	VinlFix	

Return Branch Detail Table

Name	Grille Size (in)	Htg (cfm)	Clg (cfm)	TEL (ft)	Design FR	Veloc (fpm)	Diam (in)	H x W (in)	Stud/Joist Opening (in)	Duct Matl	Trunk
rb1	0x0	938	938	96.0	0.064	531	18.0	0x 0		VIFx	

APPROVED BY

12/7/2022

Approval of this document does not authorize or approve any deviation or deviations from the requirements of applicable State Laws.

Roger Colson

Bold/italic values have been manually overridden



Generated by REScheck-Web Software Compliance Certificate

Project 1B1503-R36

Energy Code: **2018 IECC**
 Location: **Harnett County, North Carolina**
 Construction Type: **Single-family**
 Project Type: **New Construction**
 Orientation: **Unspecified**
 Conditioned Floor Area: **2,077 ft²**
 Glazing Area: **15%**
 Climate Zone: **4 (3499 HDD)**
 Permit Date:
 Permit Number:

APPROVED BY



12/7/2022

Approval of this document does not authorize or approve any deviation or deviations from the requirements of applicable State Laws.

Roger Colson

Construction Site:
74 Bait Road
Dunn, North Carolina 28334

Owner/Agent:
HILL
CUSTOM BUILT

Designer/Contractor:
R-Anell Housing Group, LLC
Commodore Homes, LLC
235 Anthony Grove Rd.
Crouse, NC 28033

Compliance: Passes using UA trade-off

Compliance: **1.6% Better Than Code** Maximum UA: **305** Your UA: **300** Maximum SHGC: **0.40** Your SHGC: **0.24**

The % Better or Worse Than Code Index reflects how close to compliance the house is based on code trade-off rules. It DOES NOT provide an estimate of energy use or cost relative to a minimum-code home.

Slab-on-grade tradeoffs are no longer considered in the UA or performance compliance path in REScheck. Each slab-on-grade assembly in the specified climate zone must meet the minimum energy code insulation R-value and depth requirements.

Envelope Assemblies

Assembly	Gross Area or Perimeter	Cavity R-Value	Cont. R-Value	Prop. U-Factor	Req. U-Factor	Prop. UA	Req. UA
Ceiling 1: Flat Ceiling or Scissor Truss	2,077	38.0	0.0	0.030	0.026	62	54
Wall [1walls]: Wood Frame, 16" o.c. Orientation: Right side	267	21.0	0.0	0.057	0.060	15	16
Wall [1walls]: Wood Frame, 16" o.c. Orientation: Left side	267	21.0	0.0	0.057	0.060	14	14
Window - (2) Kinro 3658 {Qty 1}: Vinyl Frame:Double Pane with Low-E SHGC: 0.25 Orientation: Left side	29			0.340	0.320	10	9
Wall [1walls]: Wood Frame, 16" o.c. Orientation: Back	743	21.0	0.0	0.057	0.060	35	37
Door - Hinged - Exterior - 6 Panel {Qty 1}: Solid Orientation: Back	22			0.220	0.320	5	7
Window - Kinro 3658 {Qty 2}: Vinyl Frame:Double Pane with Low-E SHGC: 0.25 Orientation: Back	29			0.340	0.320	10	9

Assembly	Gross Area or Perimeter	Cavity R-Value	Cont. R-Value	Prop. U-Factor	Req. U-Factor	Prop. UA	Req. UA
Window - Kinro 3036 {Qty 1}: Vinyl Frame:Double Pane with Low-E SHGC: 0.25 Orientation: Back	8			0.340	0.320	3	3
Window - (2) Kinro 3658 {Qty 1}: Vinyl Frame:Double Pane with Low-E SHGC: 0.25 Orientation: Back	29			0.340	0.320	10	9
Window - Kinro 3656 Picture Saftey {Qty 3}: Vinyl Frame:Double Pane with Low-E SHGC: 0.24 Orientation: Back	43			0.330	0.320	14	14
Wall [1walls]: Wood Frame, 16" o.c. Orientation: Front	743	21.0	0.0	0.057	0.060	32	34
Door - Hinged - Exterior - Half Lite - Royal {Qty 1}: Solid Orientation: Front	22			0.280	0.320	6	7
Window - (2) Kinro 3658 wTrans - 7270 {Qty 3}: Vinyl Frame:Double Pane with Low-E SHGC: 0.24 Orientation: Front	108			0.340	0.320	37	35
Window - Kinro 3658 wTrans - 3670 {Qty 3}: Vinyl Frame:Double Pane with Low-E SHGC: 0.24 Orientation: Front	54			0.340	0.320	18	17
Crawl 1: Solid Concrete or Masonry Wall height: 3.0' Depth below grade: 2.0' Insulation depth: 3.0'	620	0.0	19.0	0.046	0.065	29	40

Compliance Statement: The proposed building design described here is consistent with the building plans, specifications, and other calculations submitted with the permit application. The proposed building has been designed to meet the 2018 IECC requirements in REScheck Version : REScheck-Web and to comply with the mandatory requirements listed in the REScheck Inspection Checklist.

N. Edwards - drafter
Name - Title

N. Edwards
Signature

12/6/2022
Date



Approval of this document does not authorize or
approve any deviation or deviations from the
requirements of applicable State Laws.

Roger Colson



Inspection Checklist

Energy Code: 2018 IECC

Requirements: 0.0% were addressed directly in the REScheck software

Text in the "Comments/Assumptions" column is provided by the user in the REScheck Requirements screen. For each requirement, the user certifies that a code requirement will be met and how that is documented, or that an exception is being claimed. Where compliance is itemized in a separate table, a reference to that table is provided.







Section # & Req.ID	Pre-Inspection/Plan Review	Plans Verified Value	Field Verified Value	Complies?	Comments/Assumptions
103.1, 103.2 [PR1] ¹	Construction drawings and documentation demonstrate energy code compliance for the building envelope. Thermal envelope represented on construction documents.			<input type="checkbox"/> Complies <input type="checkbox"/> Does Not <input type="checkbox"/> Not Observable <input type="checkbox"/> Not Applicable	
103.1, 103.2, 403.7 [PR3] ¹	Construction drawings and documentation demonstrate energy code compliance for lighting and mechanical systems. Systems serving multiple dwelling units must demonstrate compliance with the IECC Commercial Provisions.			<input type="checkbox"/> Complies <input type="checkbox"/> Does Not <input type="checkbox"/> Not Observable <input type="checkbox"/> Not Applicable	
302.1, 403.7 [PR2] ²	Heating and cooling equipment is sized per ACCA Manual S based on loads calculated per ACCA Manual J or other methods approved by the code official.	Heating: Btu/hr____ Cooling: Btu/hr____	Heating: Btu/hr____ Cooling: Btu/hr____	<input type="checkbox"/> Complies <input type="checkbox"/> Does Not <input type="checkbox"/> Not Observable <input type="checkbox"/> Not Applicable	

Additional Comments/Assumptions:

APPROVED BY

 12/7/2022
 Approval of this document does not authorize or approve any deviation or deviations from the requirements of applicable State Laws.
 Roger Colson

1 High Impact (Tier 1)	2 Medium Impact (Tier 2)	3 Low Impact (Tier 3)
------------------------	--------------------------	-----------------------

Section # & Req.ID	Foundation Inspection	Plans Verified Value	Field Verified Value	Complies?	Comments/Assumptions
402.2.11 [FO7] ¹ 	Unvented crawl space wall insulation R-value.	R-____ R-____	R-____ R-____	<input type="checkbox"/> Complies <input type="checkbox"/> Does Not <input type="checkbox"/> Not Observable <input type="checkbox"/> Not Applicable	See the Envelope Assemblies table for values.
303.2 [FO8] ¹ 	Unvented crawl space wall insulation installed per manufacturer's instructions.			<input type="checkbox"/> Complies <input type="checkbox"/> Does Not <input type="checkbox"/> Not Observable <input type="checkbox"/> Not Applicable	
402.2.11 [FO9] ¹ 	Unvented crawl space continuous vapor retarder installed over exposed earth, joints overlapped by 6 in. and sealed, extending at least 6 in. up and attached to the wall.			<input type="checkbox"/> Complies <input type="checkbox"/> Does Not <input type="checkbox"/> Not Observable <input type="checkbox"/> Not Applicable	
402.2.11 [FO10] ¹ 	Unvented crawl space wall insulation depth of burial or distance from top of wall.	____ in.	____ in.	<input type="checkbox"/> Complies <input type="checkbox"/> Does Not <input type="checkbox"/> Not Observable <input type="checkbox"/> Not Applicable	See the Envelope Assemblies table for values.
303.2.1 [FO11] ² 	A protective covering is installed to protect exposed exterior insulation and extends a minimum of 6 in. below grade.			<input type="checkbox"/> Complies <input type="checkbox"/> Does Not <input type="checkbox"/> Not Observable <input type="checkbox"/> Not Applicable	
403.9 [FO12] ² 	Snow- and ice-melting system controls installed.			<input type="checkbox"/> Complies <input type="checkbox"/> Does Not <input type="checkbox"/> Not Observable <input type="checkbox"/> Not Applicable	

Additional Comments/Assumptions:

APPROVED BY



12/7/2022

Approval of this document does not authorize or approve any deviation or deviations from the requirements of applicable State Laws.

Roger Colson

1 High Impact (Tier 1)	2 Medium Impact (Tier 2)	3 Low Impact (Tier 3)
------------------------	--------------------------	-----------------------

Section # & Req.ID	Framing / Rough-In Inspection	Plans Verified Value	Field Verified Value	Complies?	Comments/Assumptions
402.1.1, 402.3.4 [FR1] ¹	Door U-factor.	U-____	U-____	<input type="checkbox"/> Complies <input type="checkbox"/> Does Not <input type="checkbox"/> Not Observable <input type="checkbox"/> Not Applicable	See the Envelope Assemblies table for values.
402.1.1, 402.3.1, 402.3.3, 402.5 [FR2] ¹	Glazing U-factor (area-weighted average).	U-____	U-____	<input type="checkbox"/> Complies <input type="checkbox"/> Does Not <input type="checkbox"/> Not Observable <input type="checkbox"/> Not Applicable	See the Envelope Assemblies table for values.
303.1.3 [FR4] ¹	U-factors of fenestration products are determined in accordance with the NFRC test procedure or taken from the default table.			<input type="checkbox"/> Complies <input type="checkbox"/> Does Not <input type="checkbox"/> Not Observable <input type="checkbox"/> Not Applicable	
402.4.1.1 [FR23] ¹	Air barrier and thermal barrier installed per manufacturer's instructions.			<input type="checkbox"/> Complies <input type="checkbox"/> Does Not <input type="checkbox"/> Not Observable <input type="checkbox"/> Not Applicable	
402.4.3 [FR20] ¹	Fenestration that is not site built is listed and labeled as meeting AAMA /WDMA/CSA 101/I.S.2/A440 or has infiltration rates per NFRC 400 that do not exceed code limits.			<input type="checkbox"/> Complies <input type="checkbox"/> Does Not <input type="checkbox"/> Not Observable <input type="checkbox"/> Not Applicable	
402.4.5 [FR16] ²	IC-rated recessed lighting fixtures sealed at housing/interior finish and labeled to indicate ≤ 2.0 cfm leakage at 75 Pa.			<input type="checkbox"/> Complies <input type="checkbox"/> Does Not <input type="checkbox"/> Not Observable <input type="checkbox"/> Not Applicable	
403.3.1 [FR12] ¹	Supply and return ducts in attics insulated $\geq R-8$ where duct is ≥ 3 inches in diameter and $\geq R-6$ where < 3 inches. Supply and return ducts in other portions of the building insulated $\geq R-6$ for diameter ≥ 3 inches and $R-4.2$ for < 3 inches in diameter.			<input type="checkbox"/> Complies <input type="checkbox"/> Does Not <input type="checkbox"/> Not Observable <input type="checkbox"/> Not Applicable	
403.3.2 [FR13] ¹	Ducts, air handlers and filter boxes are sealed with joints/seams compliant with International Mechanical Code or International Residential Code, as applicable.			<input type="checkbox"/> Complies <input type="checkbox"/> Does Not <input type="checkbox"/> Not Observable <input type="checkbox"/> Not Applicable	
403.3.5 [FR15] ³	Building cavities are not used as ducts or plenums.			<input type="checkbox"/> Complies <input type="checkbox"/> Does Not <input type="checkbox"/> Not Observable <input type="checkbox"/> Not Applicable	
403.4 [FR17] ²	HVAC piping conveying fluids above 105 °F or chilled fluids below 55 °F are insulated to $\geq R-3$.	R-____	R-____	<input type="checkbox"/> Complies <input type="checkbox"/> Does Not <input type="checkbox"/> Not Observable <input type="checkbox"/> Not Applicable	
403.4.1 [FR24] ¹	Protection of insulation on HVAC piping.			<input type="checkbox"/> Complies <input type="checkbox"/> Does Not <input type="checkbox"/> Not Observable <input type="checkbox"/> Not Applicable	
403.5.3 [FR18] ²	Hot water pipes are insulated to $\geq R-3$.	R-____	R-____	<input type="checkbox"/> Complies <input type="checkbox"/> Does Not <input type="checkbox"/> Not Observable <input type="checkbox"/> Not Applicable	

APPROVED BY



12/7/2022

Approval of this document does not authorize or approve any deviation or deviations from the requirements of applicable State Laws.

Roger Colson

1 High Impact (Tier 1)	2 Medium Impact (Tier 2)	3 Low Impact (Tier 3)
------------------------	--------------------------	-----------------------

Section # & Req.ID	Framing / Rough-In Inspection	Plans Verified Value	Field Verified Value	Complies?	Comments/Assumptions
403.6 [FR19] ²	Automatic or gravity dampers are installed on all outdoor air intakes and exhausts.			<input type="checkbox"/> Complies <input type="checkbox"/> Does Not <input type="checkbox"/> Not Observable <input type="checkbox"/> Not Applicable	

Additional Comments/Assumptions:

APPROVED BY
 12/7/2022
Approval of this document does not authorize or approve any deviation or deviations from the requirements of applicable State Laws.
Roger Colson

1	High Impact (Tier 1)	2	Medium Impact (Tier 2)	3	Low Impact (Tier 3)
---	----------------------	---	------------------------	---	---------------------

Section # & Req.ID	Insulation Inspection	Plans Verified Value	Field Verified Value	Complies?	Comments/Assumptions
303.1 [IN13] ²	All installed insulation is labeled or the installed R-values provided.			<input type="checkbox"/> Complies <input type="checkbox"/> Does Not <input type="checkbox"/> Not Observable <input type="checkbox"/> Not Applicable	
402.1.1, 402.2.5, 402.2.6 [IN3] ¹	Wall insulation R-value. If this is a mass wall with at least 1/2 of the wall insulation on the wall exterior, the exterior insulation requirement applies (FR10).	R-_____ <input type="checkbox"/> Wood <input type="checkbox"/> Mass <input type="checkbox"/> Steel	R-_____ <input type="checkbox"/> Wood <input type="checkbox"/> Mass <input type="checkbox"/> Steel	<input type="checkbox"/> Complies <input type="checkbox"/> Does Not <input type="checkbox"/> Not Observable <input type="checkbox"/> Not Applicable	See the Envelope Assemblies table for values.
303.2 [IN4] ¹	Wall insulation is installed per manufacturer's instructions.			<input type="checkbox"/> Complies <input type="checkbox"/> Does Not <input type="checkbox"/> Not Observable <input type="checkbox"/> Not Applicable	

Additional Comments/Assumptions:

APPROVED BY

 12/7/2022

Approval of this document does not authorize or approve any deviation or deviations from the requirements of applicable State Laws.

Roger Colson

1 High Impact (Tier 1)	2 Medium Impact (Tier 2)	3 Low Impact (Tier 3)
------------------------	--------------------------	-----------------------

Section # & Req.ID	Final Inspection Provisions	Plans Verified Value	Field Verified Value	Complies?	Comments/Assumptions
402.1.1, 402.2.1, 402.2.2, 402.2.6 [FI1] ¹	Ceiling insulation R-value.	R-____ <input type="checkbox"/> Wood <input type="checkbox"/> Steel	R-____ <input type="checkbox"/> Wood <input type="checkbox"/> Steel	<input type="checkbox"/> Complies <input type="checkbox"/> Does Not <input type="checkbox"/> Not Observable <input type="checkbox"/> Not Applicable	See the Envelope Assemblies table for values.
303.1.1.1, 303.2 [FI2] ¹	Ceiling insulation installed per manufacturer's instructions. Blown insulation marked every 300 ft ² .			<input type="checkbox"/> Complies <input type="checkbox"/> Does Not <input type="checkbox"/> Not Observable <input type="checkbox"/> Not Applicable	
402.2.3 [FI22] ²	Vented attics with air permeable insulation include baffle adjacent to soffit and eave vents that extends over insulation.			<input type="checkbox"/> Complies <input type="checkbox"/> Does Not <input type="checkbox"/> Not Observable <input type="checkbox"/> Not Applicable	
402.2.4 [FI3] ¹	Attic access hatch and door insulation ≥R-value of the adjacent assembly.	R-____	R-____	<input type="checkbox"/> Complies <input type="checkbox"/> Does Not <input type="checkbox"/> Not Observable <input type="checkbox"/> Not Applicable	
402.4.1.2 [FI17] ¹	Blower door test @ 50 Pa. ≤=5 ach in Climate Zones 1-2, and ≤=3 ach in Climate Zones 3-8.	ACH 50 = ____	ACH 50 = ____	<input type="checkbox"/> Complies <input type="checkbox"/> Does Not <input type="checkbox"/> Not Observable <input type="checkbox"/> Not Applicable	
403.3.3 [FI27] ¹	Ducts are pressure tested to determine air leakage with either: Rough-in test: Total leakage measured with a pressure differential of 0.1 inch w.g. across the system including the manufacturer's air handler enclosure if installed at time of test. Postconstruction test: Total leakage measured with a pressure differential of 0.1 inch w.g. across the entire system including the manufacturer's air handler enclosure.	____ cfm/100 ft ²	____ cfm/100 ft ²	<input type="checkbox"/> Complies <input type="checkbox"/> Does Not <input type="checkbox"/> Not Observable <input type="checkbox"/> Not Applicable	
403.3.4 [FI4] ¹	Duct tightness test result of ≤=4 cfm/100 ft ² across the system or ≤=3 cfm/100 ft ² without air handler @ 25 Pa. For rough-in tests, verification may need to occur during Framing Inspection.	____ cfm/100 ft ²	____ cfm/100 ft ²	<input type="checkbox"/> Complies <input type="checkbox"/> Does Not <input type="checkbox"/> Not Observable <input type="checkbox"/> Not Applicable	
403.3.2.1 [FI24] ¹	Air handler leakage designated by manufacturer at ≤=2% of design air flow.			<input type="checkbox"/> Complies <input type="checkbox"/> Does Not <input type="checkbox"/> Not Observable <input type="checkbox"/> Not Applicable	
403.1.1 [FI9] ²	Programmable thermostats installed for control of primary heating and cooling systems and initially set by manufacturer to code specifications.			<input type="checkbox"/> Complies <input type="checkbox"/> Does Not <input type="checkbox"/> Not Observable <input type="checkbox"/> Not Applicable	
403.1.2 [FI10] ²	Heat pump thermostat installed on heat pumps.			<input type="checkbox"/> Complies <input type="checkbox"/> Does Not <input type="checkbox"/> Not Observable <input type="checkbox"/> Not Applicable	
403.5.1 [FI11] ²	Circulating service hot water systems have automatic or accessible manual controls.			<input type="checkbox"/> Complies <input type="checkbox"/> Does Not <input type="checkbox"/> Not Observable <input type="checkbox"/> Not Applicable	

APPROVED BY
NIA 12/7/2022
Approval of this document does not authorize or approve any deviation or deviations from the requirements of applicable State Laws.
Roger Colson

1 High Impact (Tier 1)
2 Medium Impact (Tier 2)
3 Low Impact (Tier 3)

Section # & Req.ID	Final Inspection Provisions	Plans Verified Value	Field Verified Value	Complies?	Comments/Assumptions
403.6.1 [FI25] ²	All mechanical ventilation system fans not part of tested and listed HVAC equipment meet efficacy and air flow limits per Table R403.6.1.			<input type="checkbox"/> Complies <input type="checkbox"/> Does Not <input type="checkbox"/> Not Observable <input type="checkbox"/> Not Applicable	
403.2 [FI26] ²	Hot water boilers supplying heat through one- or two-pipe heating systems have outdoor setback control to lower boiler water temperature based on outdoor temperature.			<input type="checkbox"/> Complies <input type="checkbox"/> Does Not <input type="checkbox"/> Not Observable <input type="checkbox"/> Not Applicable	
403.5.1.1 [FI28] ²	Heated water circulation systems have a circulation pump. The system return pipe is a dedicated return pipe or a cold water supply pipe. Gravity and thermosyphon circulation systems are not present. Controls for circulating hot water system pumps start the pump with signal for hot water demand within the occupancy. Controls automatically turn off the pump when water is in circulation loop is at set-point temperature and no demand for hot water exists.			<input type="checkbox"/> Complies <input type="checkbox"/> Does Not <input type="checkbox"/> Not Observable <input type="checkbox"/> Not Applicable	
403.5.1.2 [FI29] ²	Electric heat trace systems comply with IEEE 515.1 or UL 515. Controls automatically adjust the energy input to the heat tracing to maintain the desired water temperature in the piping.			<input type="checkbox"/> Complies <input type="checkbox"/> Does Not <input type="checkbox"/> Not Observable <input type="checkbox"/> Not Applicable	
403.5.2 [FI30] ²	Demand recirculation water systems have controls that manage operation of the pump and limit the temperature of the water entering the cold water piping to $\leq 104^{\circ}\text{F}$.			<input type="checkbox"/> Complies <input type="checkbox"/> Does Not <input type="checkbox"/> Not Observable <input type="checkbox"/> Not Applicable	
403.5.4 [FI31] ²	Drain water heat recovery units tested in accordance with CSA B55.1. Potable water-side pressure loss of drain water heat recovery units < 3 psi for individual units connected to one or two showers. Potable water-side pressure loss of drain water heat recovery units < 2 psi for individual units connected to three or more showers.			<input type="checkbox"/> Complies <input type="checkbox"/> Does Not <input type="checkbox"/> Not Observable <input type="checkbox"/> Not Applicable	
404.1 [FI6] ¹	90% or more of permanent fixtures have high efficacy lamps.			<input type="checkbox"/> Complies <input type="checkbox"/> Does Not <input type="checkbox"/> Not Observable <input type="checkbox"/> Not Applicable	
404.1.1 [FI23] ³	Fuel gas lighting systems have no continuous pilot light.			<input type="checkbox"/> Complies <input type="checkbox"/> Does Not <input type="checkbox"/> Not Observable <input type="checkbox"/> Not Applicable	
401.3 [FI7] ²	Compliance certificate posted.			<input type="checkbox"/> Complies <input type="checkbox"/> Does Not <input type="checkbox"/> Not Observable <input type="checkbox"/> Not Applicable	

APPROVED BY

 12/7/2022
Approval of this document does not authorize or approve any deviation or deviations from the requirements of applicable State Laws.
Roger Colson

1 High Impact (Tier 1)
2 Medium Impact (Tier 2)
3 Low Impact (Tier 3)

Section # & Req.ID	Final Inspection Provisions	Plans Verified Value	Field Verified Value	Complies?	Comments/Assumptions
303.3 [FI18] ³	Manufacturer manuals for mechanical and water heating systems have been provided.			<input type="checkbox"/> Complies <input type="checkbox"/> Does Not <input type="checkbox"/> Not Observable <input type="checkbox"/> Not Applicable	

Additional Comments/Assumptions:

APPROVED BY
 12/7/2022
Approval of this document does not authorize or approve any deviation or deviations from the requirements of applicable State Laws.
Roger Colson

1	High Impact (Tier 1)	2	Medium Impact (Tier 2)	3	Low Impact (Tier 3)
---	----------------------	---	------------------------	---	---------------------



2018 IECC Energy Efficiency Certificate

Insulation Rating	R-Value
-------------------	---------

Above-Grade Wall	21.00
Below-Grade Wall	19.00
Floor	0.00
Ceiling / Roof	38.00
Ductwork (unconditioned spaces):	_____

Glass & Door Rating	U-Factor	SHGC
---------------------	----------	------

Window	0.34	0.24
Door	0.22	

Heating & Cooling Equipment	Efficiency
-----------------------------	------------

Heating System: _____	_____
Cooling System: _____	_____
Water Heater: _____	_____

Name: _____ Date: _____

Comments

APPROVED BY



12/7/2022

Approval of this document does not authorize or approve any deviation or deviations from the requirements of applicable State Laws.

Roger Colson



UFP INDUSTRIES

Job	Truss	MFG	Customer
105014	HMC88316	274	COMMODORE

The professional engineering seal indicates that a licensed professional has reviewed the design under the standards referenced within this document, not necessarily the current state building code. The engineering seal is not an approval to use a design in a specific state. The final determination on whether a truss design is acceptable under the locally adopted building code rest with the building official or designated appointee.



APPROVED BY



12/7/2022

Approval of this document does not authorize or approve any deviation or deviations from the requirements of applicable State Laws.

Roger Colson

NORTH CAROLINA
MODULAR PLANS REVIEW CHECKLIST

PAGE 1 of 3

revised June 2018

Manufacturer
Model number/name
3rd Party
Review Date
Reviewer

Plan Sheet Page # and NOTES

QC MANUAL (current and complete)

APPENDIX B (required and attached)

PLAN SHEETS

Each plan sheet third-party stamped with approver's name

Each plan sheets is numbered and/or indexed

GENERAL (cover sheet)

Code References

Statement regarding connection to public utilities

Statement regarding bathrooms if not included

Construction type

Occupancy classification

Fire resistance ratings (if required)

Floor live load

Roof live load

Design wind velocity

Seismic information (commercial projects)

Thermal zones

Notice to inspections department regarding items to be site inspected

FLOOR PLANS

Interior and exterior wall layouts

Door and window schedule

Light and Ventilation requirements

Attic access (size and location)

Non-prescriptive headers

Safety glazing requirements

Fire rating of Exterior walls (if applicable)

EXTERIOR ELEVATIONS

Exterior materials

Attic ventilation requirements

PLUMBING

Plan

All fixtures furnished by mfg. shown on plans

Materials (water supply & distribution, DWV, storm drainage)

Supply and waste risers, including DWV system (generic) beneath the building.

Water heater (type and capacity)

NORTH CAROLINA
MODULAR PLANS REVIEW CHECKLIST

PAGE 2 of 3

revised June 2018

Plan Sheet Page # and NOTES

MECHANICAL

Design calculations
 Installed unit capacity
 Supply and returns (locations and sizes)
 Duct sizes
 Specifications (units, ducts)
 All appliances furnished by mfg. shown on plans

ELECTRICAL

Plan
 Location of all electrical boxes
 Electrical panel location
 Note regarding main disconnect (if applicable)
 Exterior lighting and receptacles
 Ground level receptacles (if applicable)
 Smoke detector location(s)
 Electrical load calculations
 Electrical panel layout (breaker and wire sizes, circuit schedule)
 Panel and service entrance sizes
 All fixtures furnished by mfg. shown on plans

ACCESSIBILITY

(for other than 1 & 2 family dwellings)

Entrances and means of egress
 Doors, doorways, and door hardware
 Stairs and handrails
 Toilet rooms, plumbing fixtures, grab bars, etc
 Bathrooms and shower rooms
 Occupancy specific requirements
 Multi-family dwellings: Type A and B units

FLOOR X-SECTION

Joists and beam sizes and spacing
 Materials species and grade
 Sheathing, decking, and concrete as applicable
 Fastening instructions
 Insulation
 Details as required for clarification

WALL X-SECTION

Stud and column sizes and spacing
 Materials species and grade
 Sheathing and bracing
 Headers and lintels
 Finishes
 Fastening instructions
 Insulation
 Details as required for clarification

NORTH CAROLINA
MODULAR PLANS REVIEW CHECKLIST

PAGE 3 of 3

revised June 2018

Plan Sheet Page # and NOTES

CEILING / ROOF X-SECTION

- Truss, rafter, and beam spacing
- Lumber species and grade
- Sheathing and decking
- Finishes
- Fastening instructions
- Insulation
- Details including NC sealed truss designs or manual reference

FOUNDATION PLAN

- Footings, pier, and curtain wall locations and specifications
- X-sections with dimensions
- Anchorage - sill plate to piers and curtain wall
- Anchorage - building to sill plate
- Anchorage - tie downs (lateral and longitudinal)
- Soil bearing capacity
- Minimum concrete compressive strength
- Mortar type
- Ventilation requirements (with and without vapor barrier)
- Crawl space access requirements

ENERGY COMPLIANCE

- Demonstrated compliance

SET-UP INSTRUCTIONS

- Floor and ceiling connections
- Marriage wall connections
- Roof set-up and connection
- Plumbing connections
- Mechanical connections
- Electrical connections
- Fire stopping
- Air infiltration elimination
- Notice to inspections department attachment if set-up instructions are by attachment

ITEMS NOT INSPECTED IN PLANT

- List of items not inspected by 3rd. Party
- Notice to inspections department