

Date: August 22, 2022
Project: Cox Residence
Address: 209 E E St
Erwin, NC 28339

Floor Support Analysis

This report is prepared for Southeast Foundation Repair (contractor) by FDN Engineering (engineer). Floor support jacks (SmartJacks) are specified for installation at the above referenced project. The support system is intended to stabilize and potentially lift the existing floor structure – reducing deflections in the floor and supporting the vertical loads tributary to the support. Load requirements for the SmartJacks were calculated at areas identified by the contractor. See page 2 for engineering analysis assumptions and results. See pages 3 and 4 for details of the floor support system. See page 5 for a layout of the floor supports on a footprint of the structure.

To the best of my professional knowledge and belief, the design of the floor structure support system meets the structural requirements of the 2018 North Carolina State Building Code to the extent that it applies to our scope of work.

Upon completion of floor support system, the contractor shall supply engineer a log of the installed locations and lift of the SmartJacks. Engineer will evaluate the log and prepare a letter of completion.

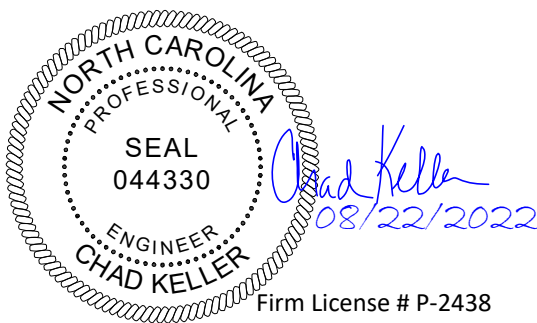

FDN Engineering, LLC

2412 N 179th St.
Omaha, NE 68116
(402) 739-9642

SmartJack Project Assumptions (contractor to confirm assumptions):

1. Structure is one-story, single family residential with wood-frame floors.
2. Soil bearing pressure at the site is a minimum of 2,000 psf.
3. SmartJack model size 350 is specified.
4. SmartJacks and supplemental girders do not support interior load-bearing walls or columns.
5. Contractor will install footings, SmartJacks, supplemental girders and all related components per the support manufacturer's installation instructions and according to their technical specs.
6. Contractor to select support base that adequately transfers load from SmartJack to soil.
7. Supplemental support girders are restrained against lateral rotation at an interval equal to or less than the SmartJack spacing.
8. SmartJacks supporting existing girders are not spaced farther than the original/existing supports; and the existing girder/joist's condition is adequate to support the new compression load.
9. Supports are not placed on sinkholes.
10. The design assumes the original structure was constructed of conventional means and methods.
11. Where supplemental girders are specified, use S4x7.7 ASTM Gr. 50 (or equal).
12. New wood-frame girders/joists that replace existing girders/joists to be at least as large as the original member, from like material, and supports placed no further than original distance.

SmartJack Analysis Notes and Results:

13. Interior floor load is assumed to not exceed 55 psf nominal load (15 psf DL + 40 psf LL), per Code.
14. SmartJacks are designed to support axial compression load only; with a max height of 9'-0".
15. Maximum total load on SmartJack is **2,100 lbs.**
16. SmartJack spacing along the supported girder (or tributary length) shall not exceed **6'-0" O.C.**

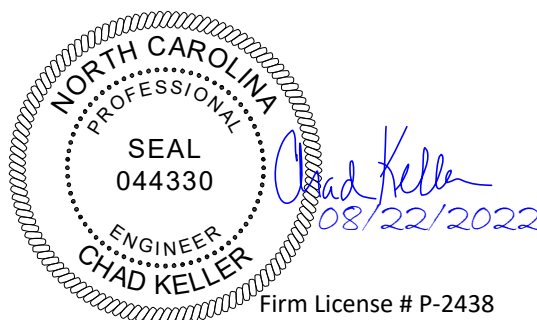

Note:
See manufacturer's specifications for more information regarding the post, top bracket and base plate's material and capacities.

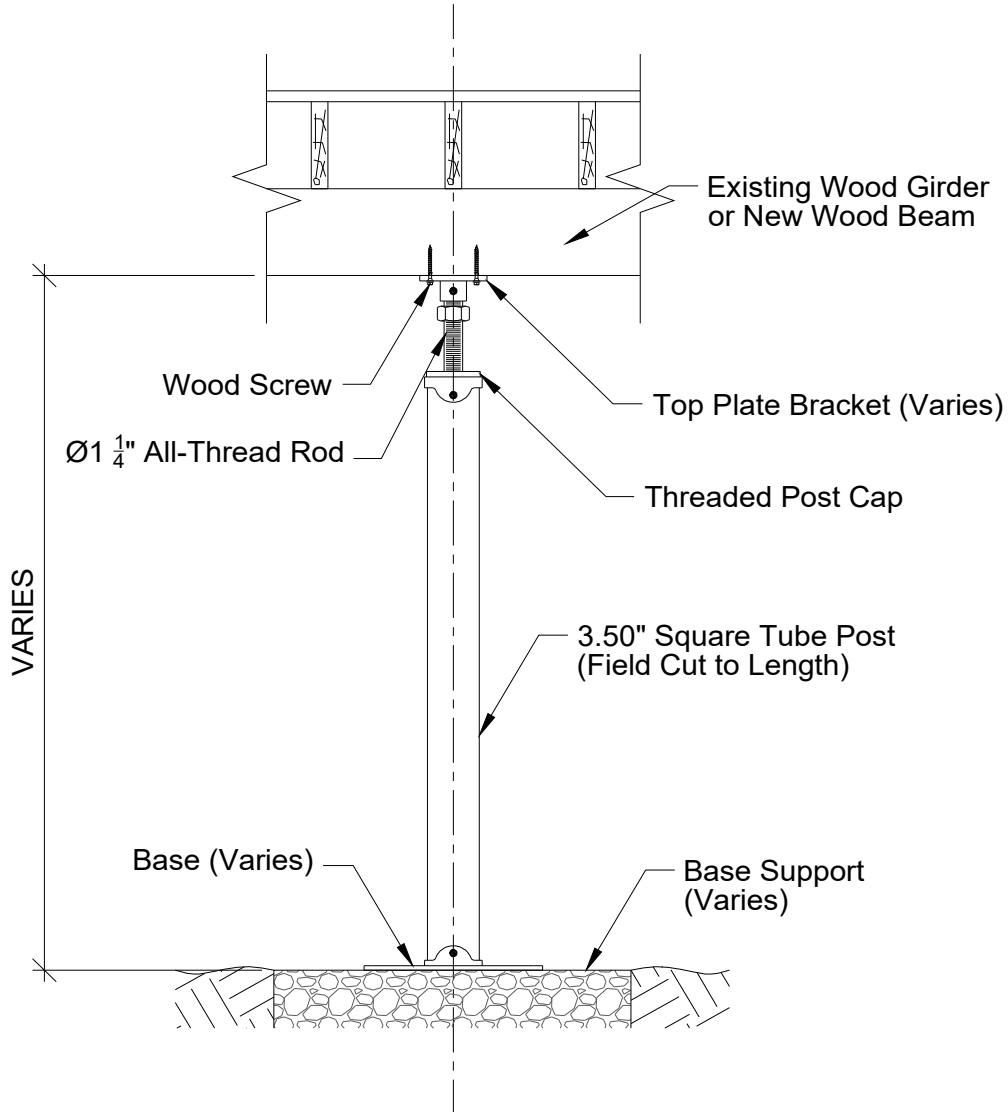

General SmartJack Detail
Shown with Top Plate for Wood Attachment
(See Following Page for Acceptable Variations)



All below variations shown are structurally acceptable and may be used at the contractor's discretion based on field conditions.

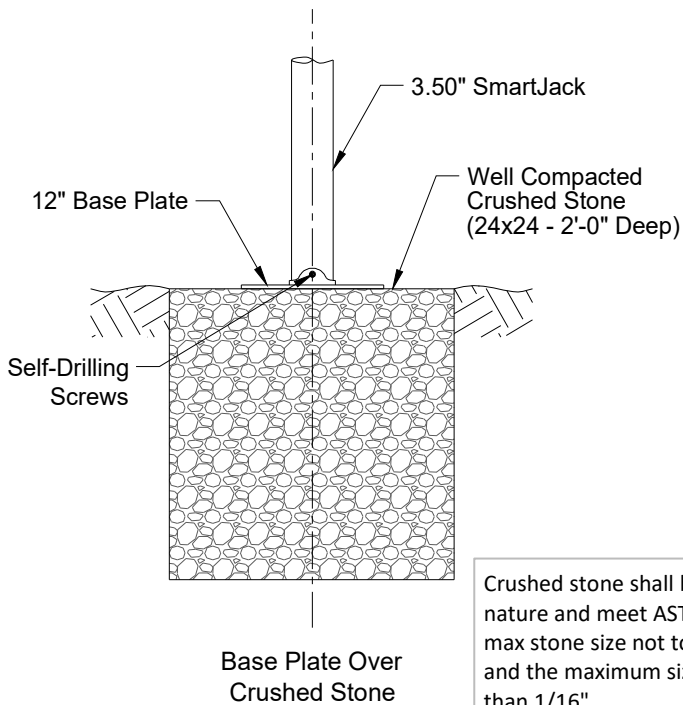
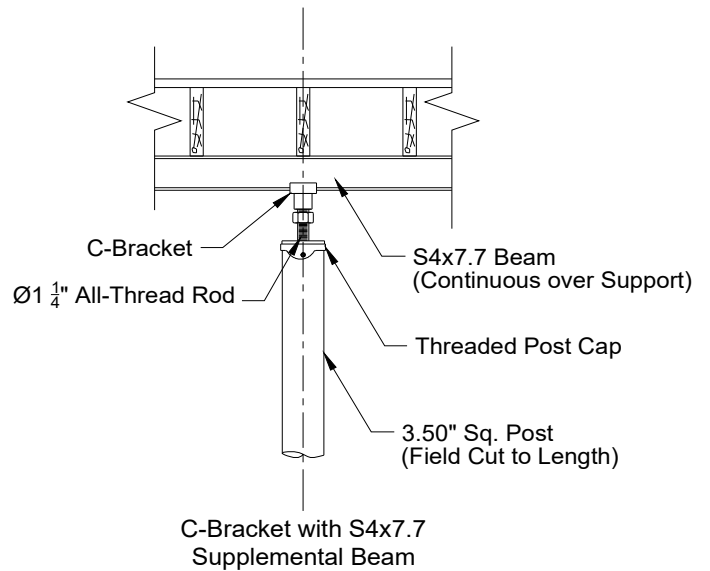
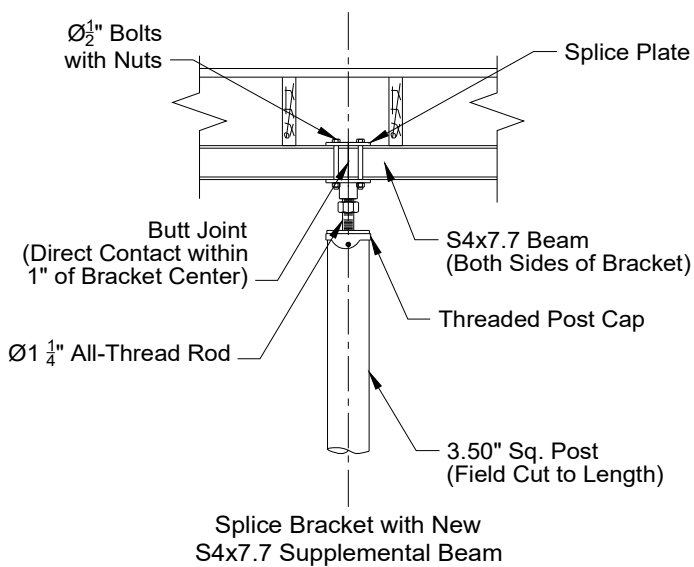

Crushed stone shall be angular in nature and meet ASTM C33, with max stone size not to exceed 1/2" and the maximum size no smaller than 1/16".

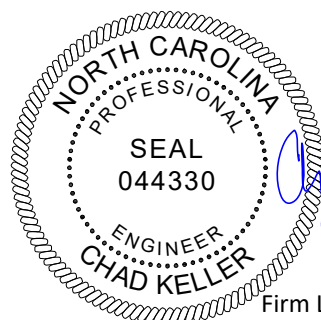
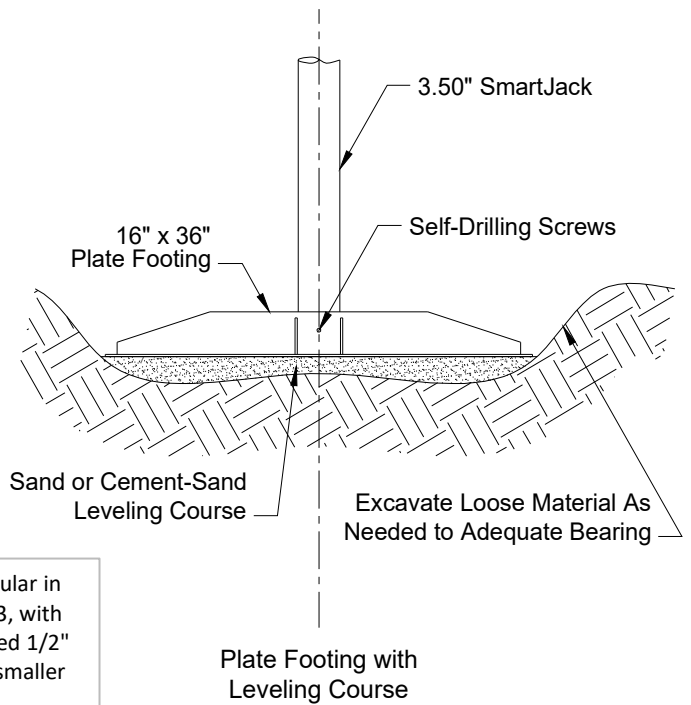

Chad Keller
 08/22/2022

SmartJack Notes:

1. Residential construction, one-story.
2. Layout of (3) SmartJacks Model 350 for floor support at **6'-0" O.C., max.**
3. Install per SmartJack manufacturer's instructions and technical specifications.
4. Notify engineer if design assumptions are discovered inaccurate.

Follow all floor framing requirements specified in Chapter 5 of the International Residential Code.

Per R317 of the Code, contractor to use preservative-treated wood if wood joists are closer than 18 inches to exposed ground. See R317 for more specific information.

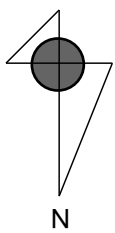
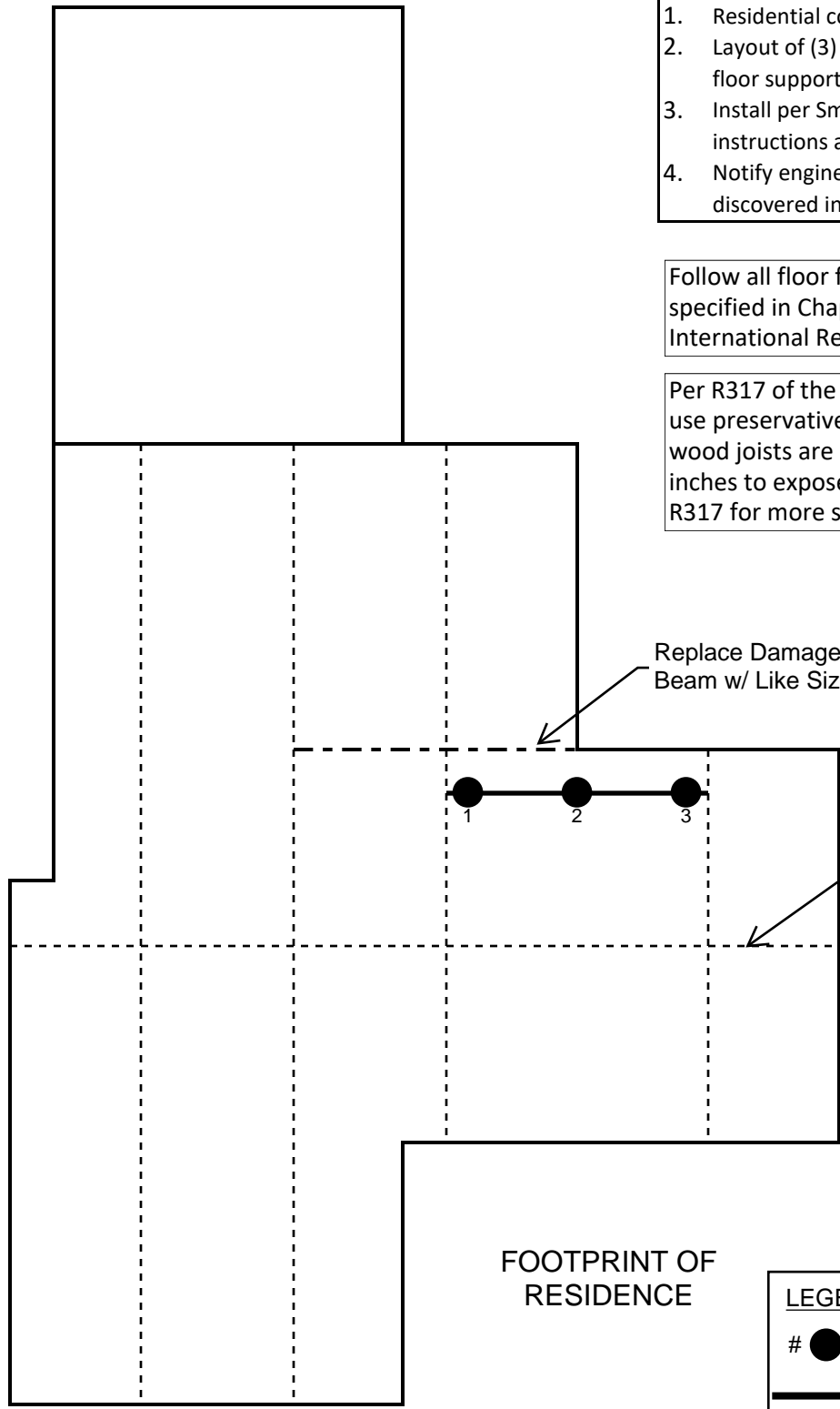

FRONT HOUSE

FOOTPRINT OF RESIDENCE

LEGEND:

- # ● Indicates SmartJack and Mark Number
- Supplemental Girder
- - - - - Replace Main Beam
- Existing Beam

DRAWING NOT TO SCALE

Project:
 Cox Residence
 209 E E St
 Erwin, NC 28339

FDN Engineering, LLC
 2412 N 179th St.
 Omaha, NE 68116
 (402) 739-9642