

1 First Floor Plan
1/4" = 1'-0"

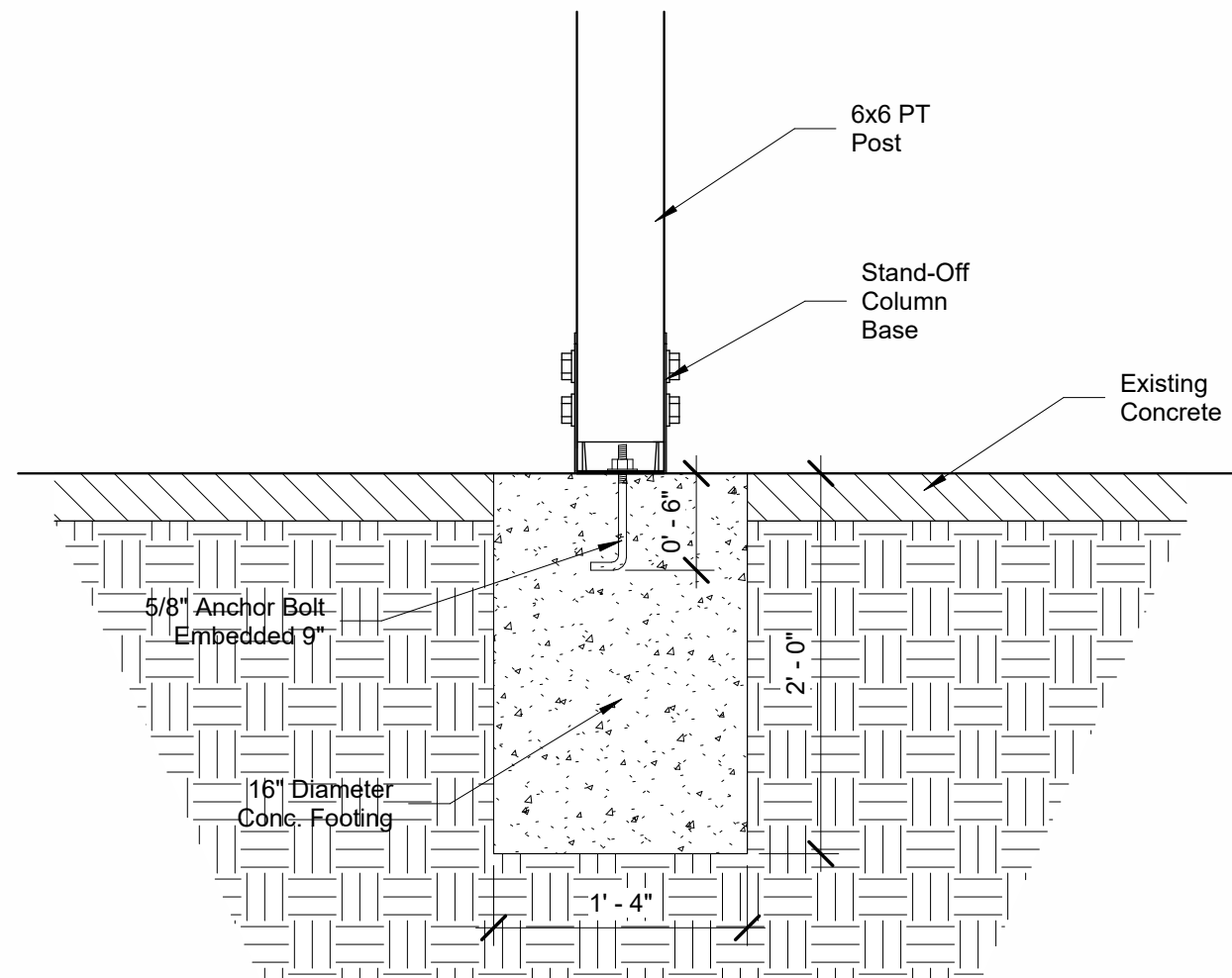

2 Footing Detail
1" = 1'-0"

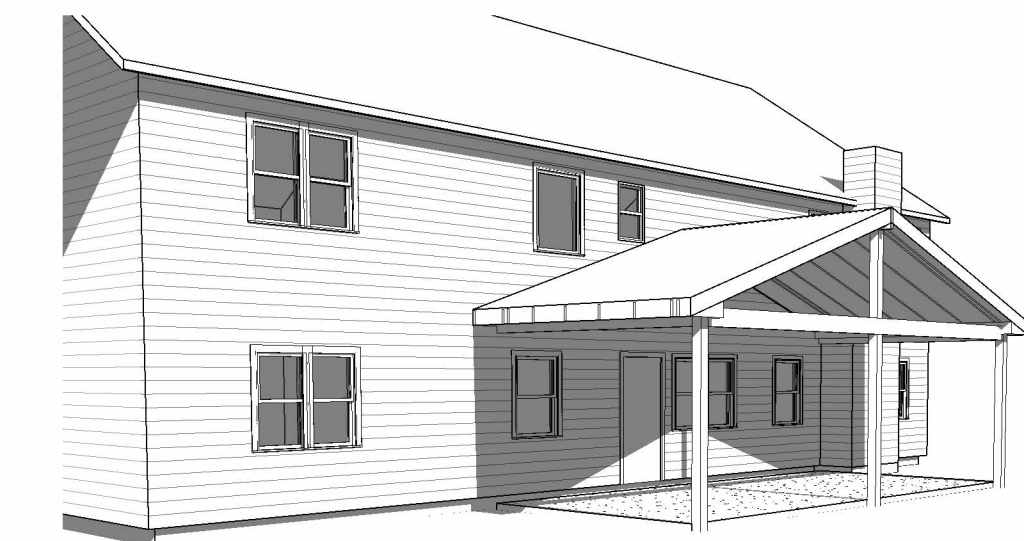

6 3D View (1)

- General Notes:**
- All dimensions are given from the exterior face of the stud to the centerline of interior studs unless otherwise noted.
 - All work shall be performed in conformance with the 2018 NC Building Code for One and Two Family Dwellings and all referenced standards.
 - All finishes, appliances, equipment and fixtures shall be coordinated by Owner and G.C.
 - G.C. to field verify all existing dimensions and conditions prior to commencing work.
 - Drawings are an instrument to communicate intent of construction. Do not scale drawings.
 - All doors and windows to be selected by Owner and provided and installed by G.C.
 - All casework to be selected by Owner and provided and installed by G.C.

IT IS THE SOLE RESPONSIBILITY OF THE CONTRACTOR AND/OR BUILDER TO CONFORM TO ALL STANDARDS, PROVISIONS, REQUIREMENTS, METHODS OF CONSTRUCTION AND USES OF MATERIALS, IN BUILDING CODES ANY OTHER LOCAL AGENCIES AND IN ACCORDANCE WITH GOOD ENGINEERING AND CONSTRUCTION PRACTICES.

I CERTIFY THAT THE CONSTRUCTION EXHIBITS FOR (IDENTIFICATION OF THE PROPERTY BY HOUSE TYPE, LOT, BLOCK, SUBDIVISION NAME, AND SO ON) MEET ALL LOCAL CODE REQUIREMENTS AND ARE IN SUBSTANTIAL CONFORMITY WITH BOTH SAH AND VA MINIMUM PROPERTY REQUIREMENTS. ALL BUILDING STANDARDS AS SET FORTH BY THE INTERNATIONAL CODE COUNCIL (ICC) AND FEDERAL SAFE DRINKING WATER PLUMBING STANDARD.

DESIGNED BY:
TIMOTHY PEPPERS JR.
RESIDENTIAL DESIGN
CONSULTANT
CAMERON
NORTH CAROLINA
(910) 644-4587

PROPERTY OF TPJR
DRAWINGS AND SPECIFICATIONS AS INSTRUMENTS OF SERVICE ARE AND SHALL REMAIN PROPERTY OF THE DESIGNER WHETHER THE PROJECT FOR WHICH THEY ARE MADE FOR IS EXECUTED OR NOT. THE DRAWINGS AND SPECIFICATIONS SHALL NOT BE USED BY THE OWNER ON OTHER PROJECTS OR FOR ADDITIONS TO THIS PROJECT OR FOR COMPLETION OF THIS PROJECT BY OTHERS EXCEPT BY AGREEMENT IN WRITING WITH THE APPROPRIATE COMPENSATION TO THE DESIGNER.

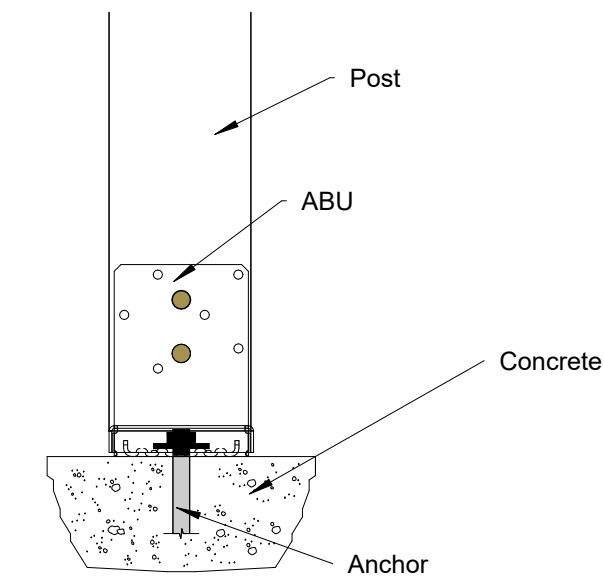

SIMPSON Strong-Tie®
Post Anchor Detail
N.T.S

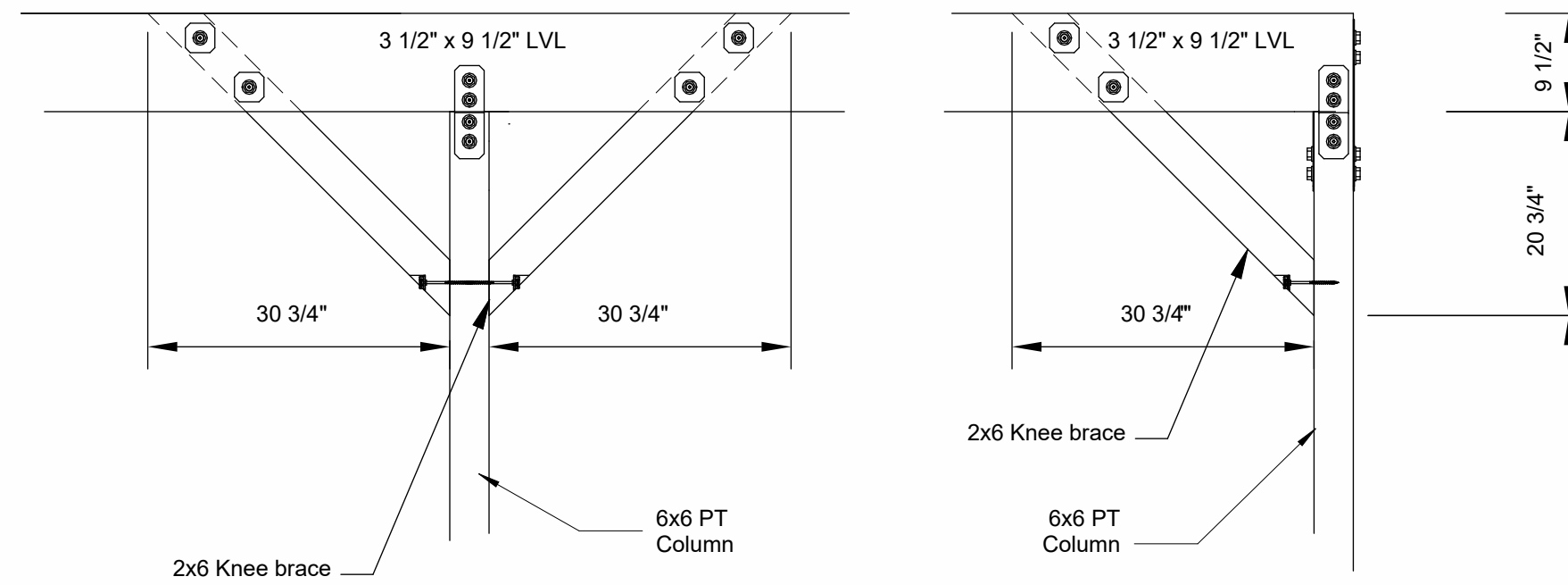

4 Knee Brace Detail
1/2" = 1'-0"



5 3D View (2)

SCALE:
As indicated

DATE:
9/14/2022

Project number
0901420220001

Drawn by TP
Checked by TP

IT IS THE SOLE RESPONSIBILITY OF THE CONTRACTOR AND/OR BUILDER TO CONFORM TO ALL STANDARDS, PROVISIONS, REQUIREMENTS, METHODS OF CONSTRUCTION AND USES OF MATERIALS, IN BUILDING CODES AND OTHER LOCAL AGENCIES AND IN ACCORDANCE WITH GOOD ENGINEERING AND CONSTRUCTION PRACTICES.

I CERTIFY THAT THE CONSTRUCTION EXHIBITS FOR (IDENTIFICATION OF THE PROPERTY BY HOUSE TYPE, LOT, BLOCK, SUBDIVISION NAME, AND SO ON) MEET ALL LOCAL CODE REQUIREMENTS AND ARE IN SUBSTANTIAL CONFORMITY WITH BOTH SAH AND VA MINIMUM PROPERTY REQUIREMENTS. ALL BUILDING STANDARDS AS SET FORTH BY THE INTERNATIONAL CODE COUNCIL (ICC) AND FEDERAL SAFE DRINKING WATER PLUMBING STANDARD.

DESIGNED BY:
TIMOTHY PEPPERS JR.
RESIDENTIAL DESIGN
CONSULTANT

CAMERON
NORTH CAROLINA
(910) 644-4587

PROPERTY OF TPJR

DRAWINGS AND SPECIFICATIONS AS INSTRUMENTS OF SERVICE ARE AND SHALL REMAIN PROPERTY OF THE DESIGNER WHETHER THE PROJECT FOR WHICH THEY ARE MADE FOR IS EXECUTED OR NOT. THE DRAWINGS AND SPECIFICATIONS SHALL NOT BE USED BY THE OWNER ON OTHER PROJECTS FOR ADDITIONS TO THIS PROJECT OR FOR COMPLETION OF THIS PROJECT BY OTHERS EXCEPT BY AGREEMENT IN WRITING WITH THE APPROPRIATE COMPENSATION TO THE DESIGNER.

Patio Cover Addition
119 Skycroft Dr
Sanford, NC 27332
Elevations

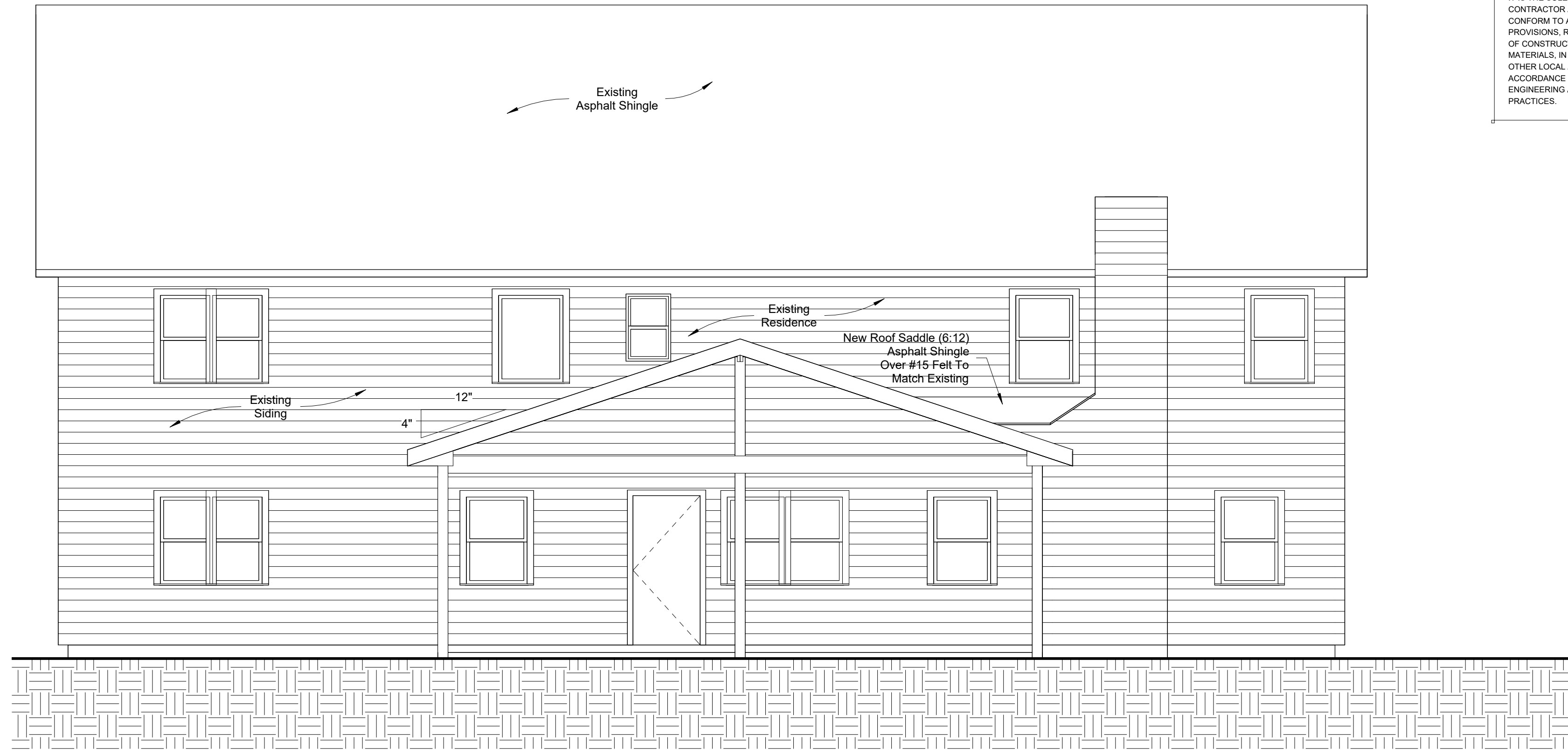

③ Rear
1/4" = 1'-0"

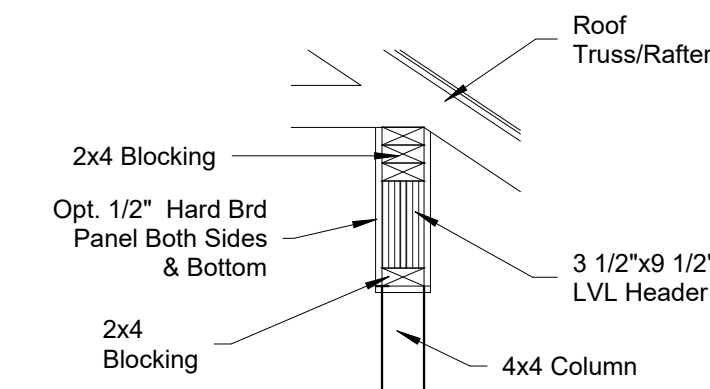
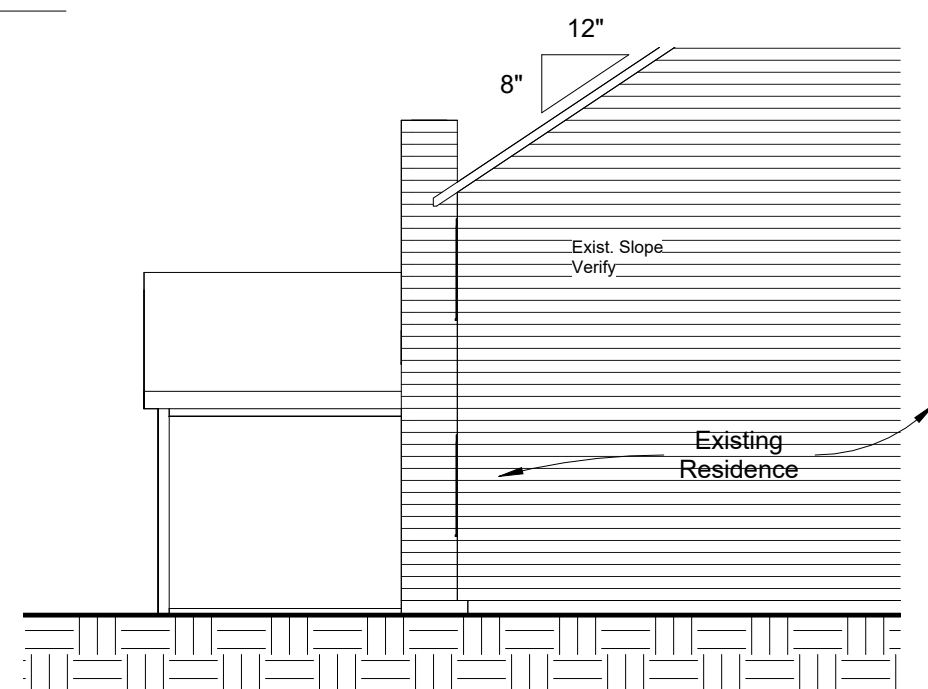

② Detail - Porch Header
3/4" = 1'-0"

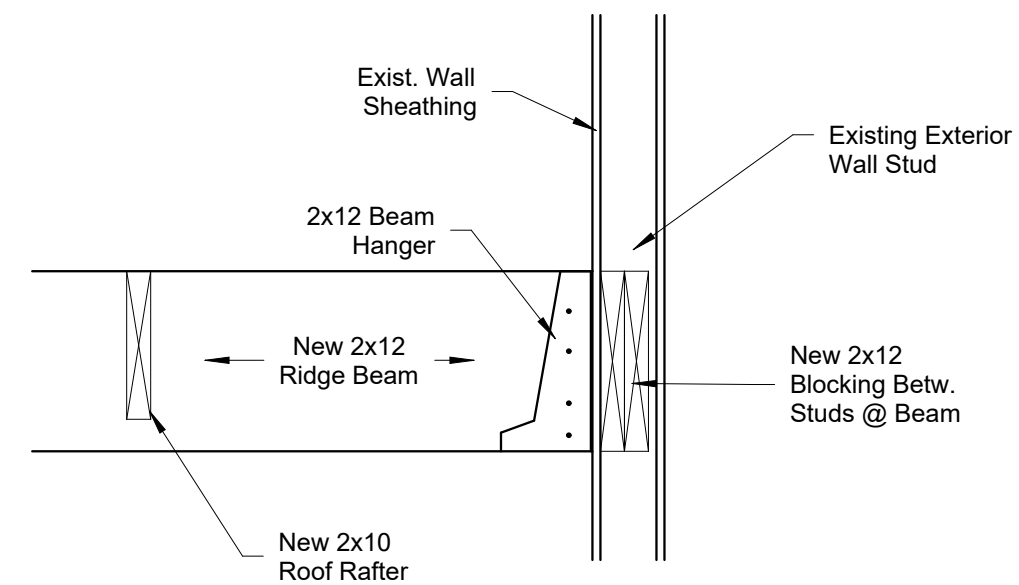

⑤ Detail - Ridge Beam
1" = 1'-0"

① Left
1/8" = 1'-0"

Elevation Notes:

- Gutters and downspouts are not shown for clarity, downspouts shall be located towards the front and rear of the house. Locate downspouts in non-visually offensive locations. General contractor shall verify existing grades and coordinate any necessary drainage requirements with owner.
- Plumbing and HVAC vents shall be grouped in attic to limit roof penetrations and to be located away from public view and shall be primed and painted to match roof color where necessary.
- Provide attic ventilation per local code requirements.
- Exterior flashing shall be correctly installed at all connections between roofs, walls, chimneys, projections and penetrations as required by approved construction practices.
- Contractor shall provide adequate attic ventilations/roof vents per local governing code. Install continuous ridge ventilation and match to roof. Provide appropriate soffit ventilation at overhangs.

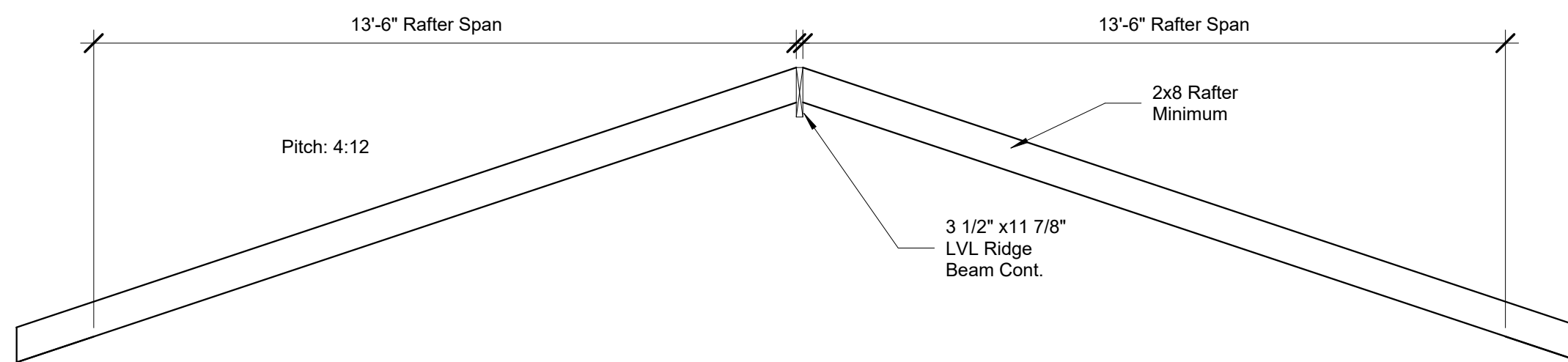

④ Roof Truss Detail
3/8" = 1'-0"

SCALE:

As indicated

DATE:

9/14/202

Project number

0901420220001

Drawn by

TP

Checked by

TP