



STRUCTURAL DESIGN

ENCLOSED BUILDING

**MAXIMUM 30'-0" WIDE X 16'- 0" EAVE HEIGHT-
BOX EAVE FRAME AND BOW FRAME**

**21 August 2020
Revision 0
M&A Project No. 20172S**

Prepared for:











**DBA Cowboys
1772 N. Andy Griffith Parkway
Mt. Airy, NC 27030**

Prepared by:

**Moore and Associates Engineering and Consulting, Inc.
1009 East Avenue
North Augusta, SC 29841**

**401 S. Main Street, Suite 200
Mt. Airy, NC 27030**



MOORE AND ASSOCIATES ENGINEERING AND CONSULTING, INC.	DRAWN BY: JG	DBA COWBOYS 1772 N. ANDY GRIFFITH PKWY MT. AIRY, NC 27030 30'-0"x16'-0" ENCLOSED STRUCTURE		
	CHECKED BY: PDH	PROJECT MGR: WSM	DATE: 8-21-20	SCALE: NTS
<small>THIS DOCUMENT IS THE PROPERTY OF MOORE AND ASSOCIATES ENGINEERING AND CONSULTING. THE UNAUTHORIZED REPRODUCTION, COPYING, OR OTHERWISE USE OF THIS DOCUMENT IS STRICTLY PROHIBITED AND ANY INFRINGEMENT THEREUPON MAY BE SUBJECT TO LEGAL ACTION.</small>	CLIENT: DBA COWBOYS	SHT. 1	DWG. NO SK-3	JOB NO: 20172S REV: 0

DRAWING INDEX

SHEET 1	PE SEAL COVER SHEET
SHEET 2	DRAWING INDEX
SHEET 3	INSTALLATION NOTES AND SPECIFICATIONS
SHEET 4	TYPICAL SIDE AND END ELEVATIONS
SHEET 5	TYPICAL RAFTER/COLUMN FRAME AND SIDE FRAMING SECTION (BOX EAVE RAFTER)
SHEET 5A	TYPICAL RAFTER/COLUMN FRAME AND SIDE FRAMING SECTION (BOX EAVE RAFTER)
SHEET 6	COLUMN CONNECTION DETAILS (BOX EAVE RAFTER)
SHEET 6A	COLUMN CONNECTION DETAILS (BOX EAVE RAFTER)
SHEET 7	TYPICAL RAFTER/COLUMN FRAME AND SIDE FRAMING SECTION (BOW EAVE RAFTER)
SHEET 7A	TYPICAL RAFTER/COLUMN FRAME AND SIDE FRAMING SECTION (BOW EAVE RAFTER)
SHEET 8	COLUMN CONNECTION DETAILS (BOW EAVE RAFTER)
SHEET 8A	COLUMN CONNECTION DETAILS (BOW EAVE RAFTER)
SHEET 9	BASE RAIL ANCHORAGE OPTIONS
SHEET 10	TYPICAL END WALL AND SIDE WALL FRAMING SECTIONS (BOX EAVE RAFTER)
SHEET 11	TYPICAL END WALL AND SIDE WALL FRAMING SECTIONS (BOW EAVE RAFTER)
SHEET 12	CONNECTION DETAILS
SHEET 13	CONNECTION DETAILS
SHEET 14	LEAN-TO OPTIONS (BOX EAVE RAFTER)
SHEET 14A	LEAN-TO OPTIONS (BOX EAVE RAFTER)
SHEET 15	LEAN-TO OPTIONS (BOW EAVE RAFTER)
SHEET 16	VERTICAL ROOF/SIDING OPTION END AND SIDE ELEVATION AND SECTION (BOX EAVE RAFTER)
SHEET 17	SIDE WALL AND END WALL HEADER OPTIONS

MOORE AND ASSOCIATES ENGINEERING AND CONSULTING, INC.	DRAWN BY: JG	DBA COWBOYS 1772 N. ANDY GRIFFITH PKWY MT. AIRY, NC 27030 30'-0"x16'-0" ENCLOSED STRUCTURE		
	CHECKED BY: PDH			
THIS DOCUMENT IS THE PROPERTY OF MOORE AND ASSOCIATES ENGINEERING AND CONSULTING. THE UNAUTHORIZED REPRODUCTION, COPYING, OR OTHERWISE USE OF THIS DOCUMENT IS STRICTLY PROHIBITED AND ANY INFRINGEMENT THEREUPON MAY BE SUBJECT TO LEGAL ACTION.	PROJECT MGR: WSM	DATE: 6-21-20	SCALE: NTS	JOB NO: 20172S
	CLIENT: DBA COWBOYS	SHT. 2	DWG. NO: SK-3	REV: 0

INSTALLATION NOTES AND SPECIFICATIONS

1. DESIGN IS FOR MAXIMUM 30'-0" WIDE x 16'-0" EAVE HEIGHT ENCLOSED STRUCTURES.
2. DESIGN WAS DONE IN ACCORDANCE WITH THE 2018 INTERNATIONAL BUILDING CODE (IBC), 2015 IBC AND 2018 NORTH CAROLINA BUILDING CODE (NCBC).
3. DESIGN LOADS ARE AS FOLLOWS:
 - A) DEAD LOAD = 15 PSF
 - B) LIVE LOAD = 12 PSF
 - C) GROUND SNOW LOAD = 45 PSF
 - = 30 PSF WITH U-CHANNEL PEAK BRACE (W ≤ 24'-0")

NOTE: UNBALANCED SNOW LOAD DUE TO DRIFTING HAS NOT BEEN EVALUATED.
4. 3-SECOND GUST ULTIMATE WIND SPEED (V_{ULT}) ≤ 145 MPH (NOMINAL WIND SPEED ≤ 112 MPH).
5. MAXIMUM RAFTER/COLUMN AND END COLUMN SPACING = 5.0 FEET (UNLESS NOTED OTHERWISE).
6. ENDWALL COLUMNS (POSTS) AND SIDE WALL COLUMNS ARE EQUIVALENT IN SIZE AND SPACING (UNLESS NOTED OTHERWISE).
7. RISK CATEGORY I.
8. WIND EXPOSURE CATEGORY B.
9. SPECIFICATIONS APPLICABLE TO 29 GAUGE METAL PANELS FASTENED DIRECTLY TO 2 1/2" x 2 1/2" - 14 GAUGE TUBE STEEL (TS) FRAMING MEMBERS (UNLESS NOTED OTHERWISE). 2 1/4" x 2 1/4" - 12 GAUGE TS MAY BE USED AS OPTIONAL FRAMING MEMBERS.
10. AVERAGE FASTENER SPACING ON-CENTERS ALONG RAFTERS OR HAT CHANNELS, AND COLUMNS (INTERIOR OR END) = 10 INCHES.
11. FASTENERS CONSIST OF #12-14x3/4" SELF-DRILLING FASTENER (SDF), USE CONTROL SEAL WASHER WITH EXTERIOR FASTENERS. SPECIFICATIONS APPLICABLE ONLY FOR MEAN ROOF HEIGHT OF 16 FEET OR LESS, AND ROOF SLOPES OF 14" (3:12 PITCH) OR LESS. SPACING REQUIREMENTS FOR OTHER ROOF HEIGHTS AND/OR SLOPES MAY VARY. ROOF SLOPES LESS THAN 3:12 REQUIRE USE OF JOINT SEALANT.
12. GROUND ANCHORS SHALL BE INSTALLED THROUGH BASE RAIL WITHIN 6" OF EACH COLUMN.
13. STANDARD GROUND ANCHORS (SOIL NAILS) CONSIST OF #4 REBAR W/ WELDED NUT x 36" LONG AND MAY BE USED IN SUITABLE SOILS. OPTIONAL ANCHORAGE MAY BE USED IN SUITABLE SOILS AND MUST BE USED IN UNSUITABLE SOILS AS NOTED.
14. WIND FORCES GOVERN OVER SEISMIC FORCES. SEISMIC PARAMETERS ANALYZED ARE:
 - SOIL SITE CLASS = D
 - RISK CATEGORY I
 - R = 3.25 I_e = 1.0
 - S_{DS} = 2.039 g V = C_sW
 - S_M = 1.258 g

MOORE AND ASSOCIATES ENGINEERING AND CONSULTING, INC.	DRAWN BY: JG	DBA COWBOYS 1772 N. ANDY GRIFFITH PKWY MT. AIRY, NC 27030 30'-0"x16'-0" ENCLOSED STRUCTURE		
	CHECKED BY: PDH			
THIS DOCUMENT IS THE PROPERTY OF MOORE AND ASSOCIATES ENGINEERING AND CONSULTING. THE UNAUTHORIZED REPRODUCTION, COPYING, OR OTHERWISE USE OF THIS DOCUMENT IS STRICTLY PROHIBITED AND ANY INFRINGEMENT THEREUPON MAY BE SUBJECT TO LEGAL ACTION.	PROJECT MGR: WSM	DATE: 8-21-20	SCALE: NTS	JOB NO: 20172S
	CLIENT: DBA COWBOYS	SHT. 3	DWG. NO: SK-3	REV: 0

BOX EAVE FRAME RAFTER STRUCTURE

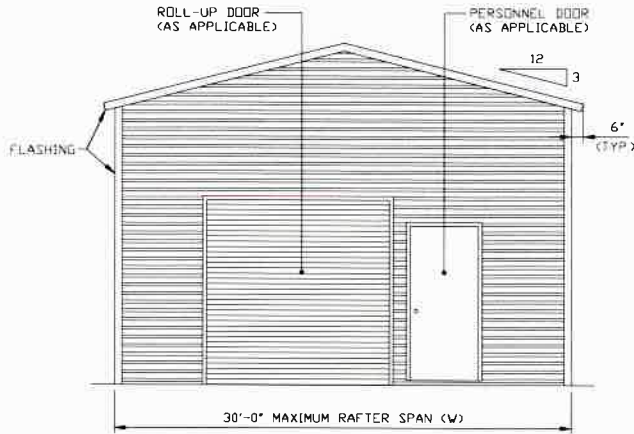

TYPICAL END ELEVATION
SCALE: NTS

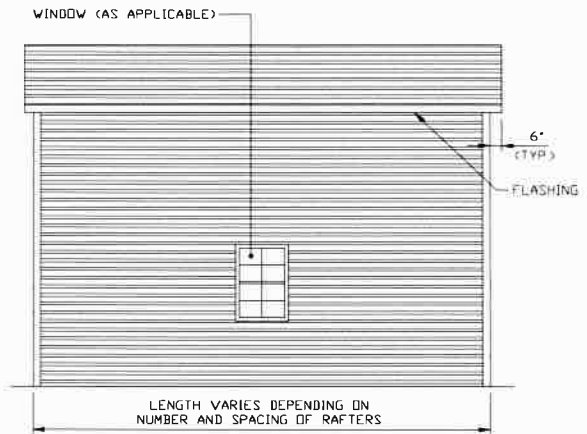

TYPICAL SIDE ELEVATION
SCALE: NTS

BOW EAVE FRAME RAFTER STRUCTURE

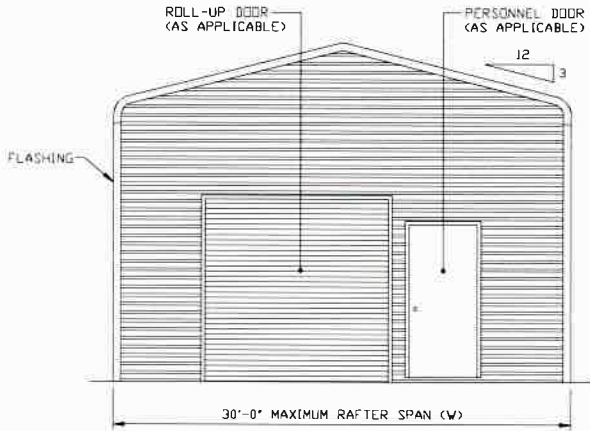

TYPICAL END ELEVATION
SCALE: NTS

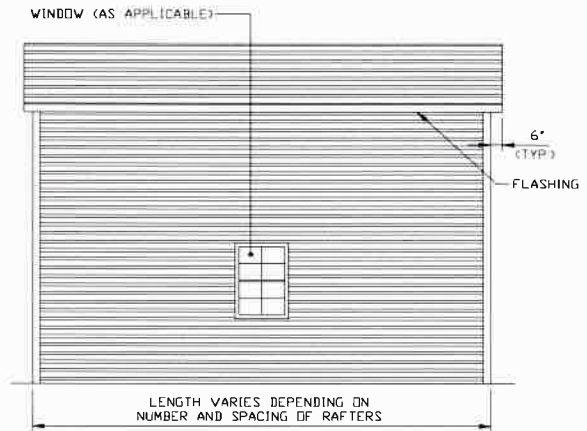

TYPICAL SIDE ELEVATION
SCALE: NTS

**MOORE AND ASSOCIATES
ENGINEERING AND CONSULTING, INC.**

DRAWN BY: JG

CHECKED BY: PDH

PROJECT MGR: WSM

CLIENT: DBA COWBOYS

DBA COWBOYS
1772 N. ANDY GRIFFITH PKWY
MT. AIRY, NC 27030
30'-0"x16'-0" ENCLOSED STRUCTURE

DATE: 8-21-20

SHT. 4

SCALE: NTS

DWG. NO: SK-3

JOB NO: 20172S

REV: 0

THIS DOCUMENT IS THE PROPERTY OF MOORE AND ASSOCIATES ENGINEERING AND CONSULTING. THE UNAUTHORIZED REPRODUCTION, COPYING, OR OTHERWISE USE OF THIS DOCUMENT IS STRICTLY PROHIBITED AND ANY INFRINGEMENT THEREUPON MAY BE SUBJECT TO LEGAL ACTION.

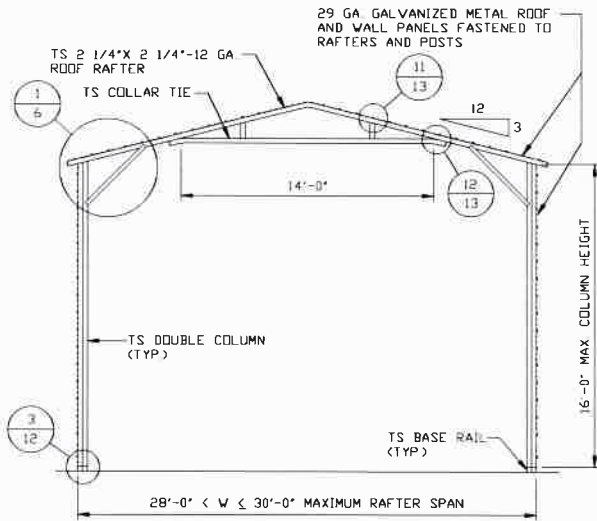

TYPICAL RAFTER/COLUMN FRAME SECTION
SCALE: NTS

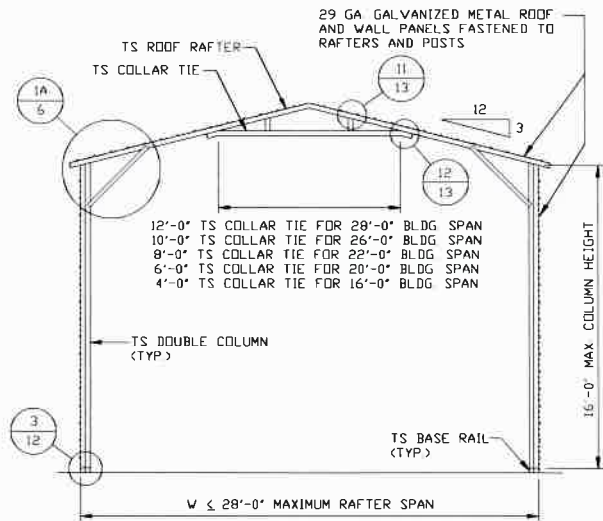

TYPICAL RAFTER/COLUMN FRAME SECTION
SCALE: NTS

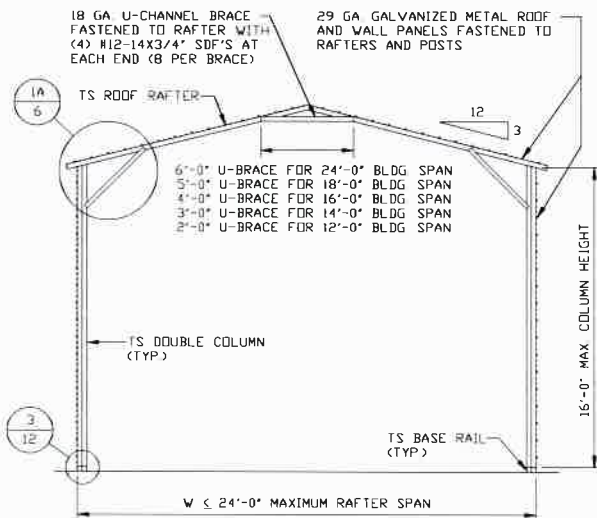

TYPICAL RAFTER/COLUMN FRAME SECTION
SCALE: NTS

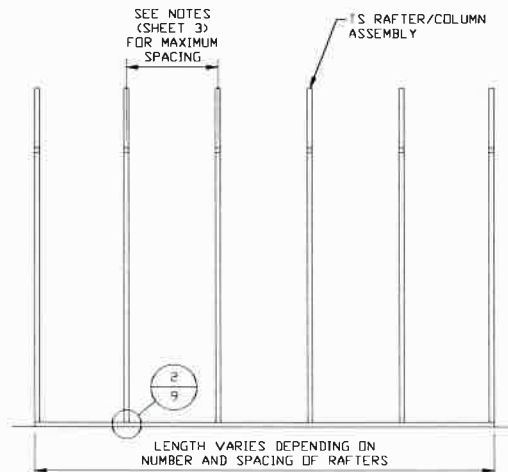

TYPICAL RAFTER/COLUMN SIDE FRAMING SECTION
SCALE: NTS

**MOORE AND ASSOCIATES
ENGINEERING AND CONSULTING, INC.**

DRAWN BY: JG

CHECKED BY: PDH

PROJECT MGR: WSM

CLIENT: DBA COWBOYS

DBA COWBOYS
1772 N. ANDY GRIFFITH PKWY
MT. AIRY, NC 27030
30'-0" x 16'-0" ENCLOSED STRUCTURE

DATE: 8-21-20

SHT. 5

SCALE: NTS

DWG. NO: SK-3

JOB NO: 20172S

REV: 0

THIS DOCUMENT IS THE PROPERTY OF MOORE AND ASSOCIATES ENGINEERING AND CONSULTING. THE UNAUTHORIZED REPRODUCTION, COPYING, OR OTHERWISE USE OF THIS DOCUMENT IS STRICTLY PROHIBITED AND ANY INFRINGEMENT THEREUPON MAY BE SUBJECT TO LEGAL ACTION.

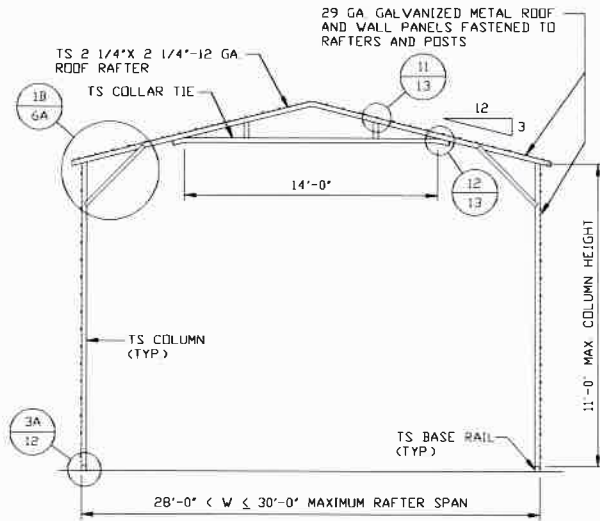

TYPICAL RAFTER/COLUMN FRAME SECTION
SCALE: NTS

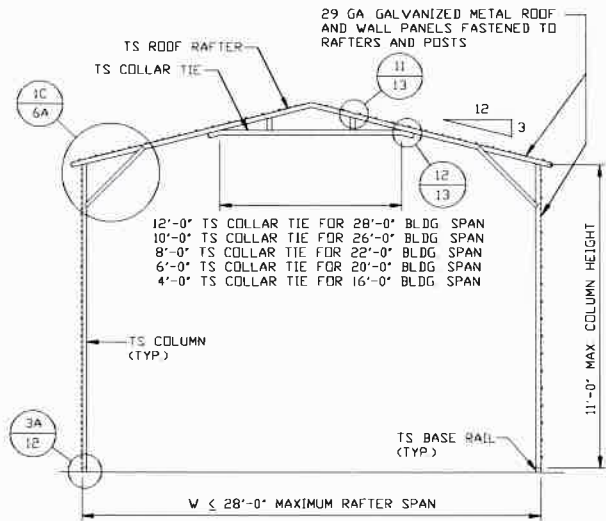

TYPICAL RAFTER/COLUMN FRAME SECTION
SCALE: NTS

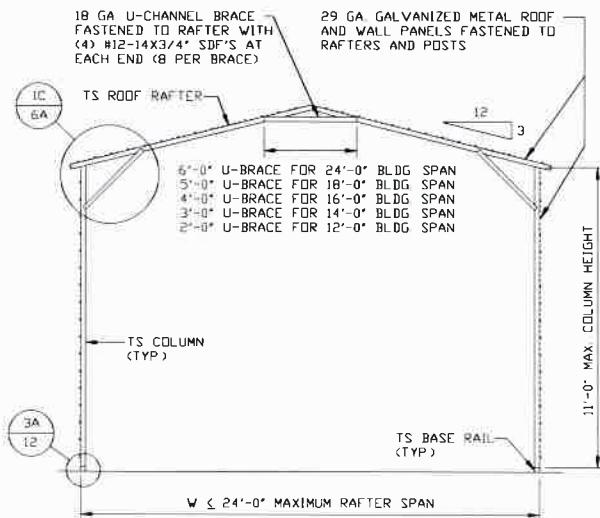

TYPICAL RAFTER/COLUMN FRAME SECTION
SCALE: NTS

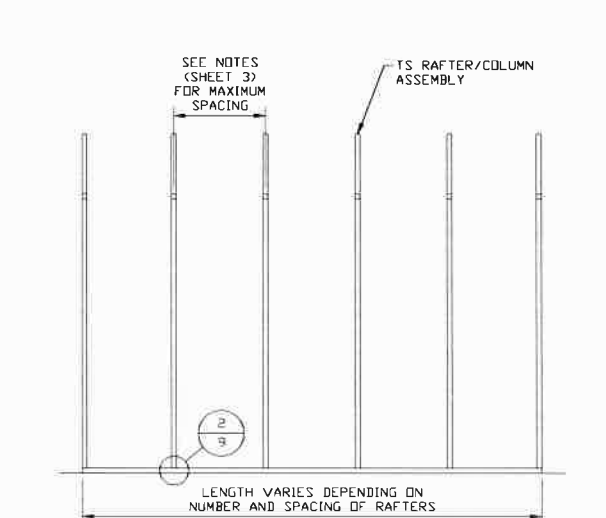

TYPICAL RAFTER/COLUMN SIDE FRAMING SECTION
SCALE: NTS

MOORE AND ASSOCIATES ENGINEERING AND CONSULTING, INC.	DRAWN BY: JG	DBA COWBOYS 1772 N. ANDY GRIFFITH PKWY MT. AIRY, NC 27030 30'-0"x16'-0" ENCLOSED STRUCTURE		
	CHECKED BY: PDH			
<small>THIS DOCUMENT IS THE PROPERTY OF MOORE AND ASSOCIATES ENGINEERING AND CONSULTING. THE UNAUTHORIZED REPRODUCTION, COPYING, OR OTHERWISE USE OF THIS DOCUMENT IS STRICTLY PROHIBITED AND ANY INFRINGEMENT THEREUPON MAY BE SUBJECT TO LEGAL ACTION.</small>	PROJECT MGR: WSM	DATE: 8-21-20	SCALE: NTS	JOB NO: 20172S
	CLIENT: DBA COWBOYS	SHT. 5A	DWG. NO: SK-3	REV: 0

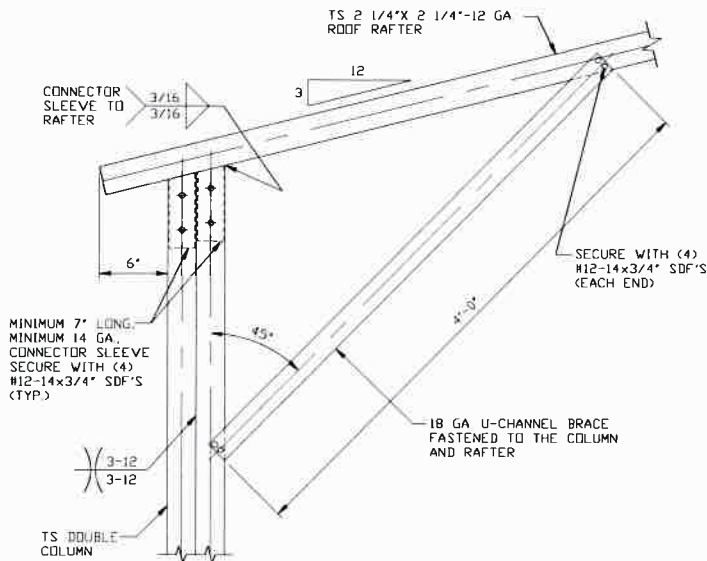

1 BOX EAVE RAFTER/CORNER POST CONNECTION DETAIL FOR HEIGHTS 11'-0" < TO <= 16'-0"

SCALE: NTS

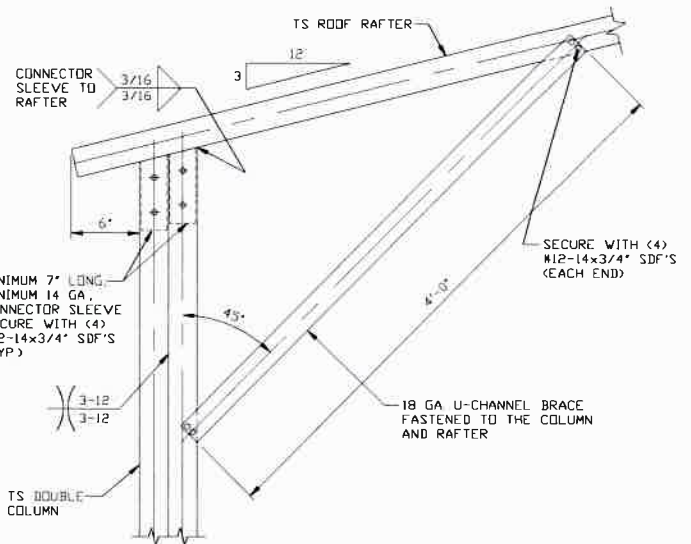

1A BOX EAVE RAFTER/CORNER POST CONNECTION DETAIL FOR HEIGHTS 11'-0" < TO <= 16'-0"

SCALE: NTS

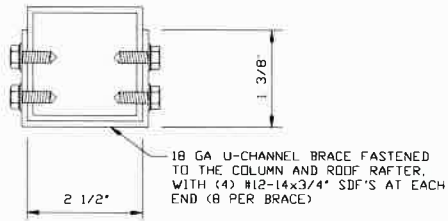

BRACE SECTION

SCALE: NTS

**MOORE AND ASSOCIATES
ENGINEERING AND CONSULTING, INC.**

DRAWN BY: JG

CHECKED BY: PDH

PROJECT MGR: WSM

CLIENT: DBA COWBOYS

DBA COWBOYS
1772 N. ANDY GRIFFITH PKWY
MT. AIRY, NC 27030
30'-0" X 16'-0" ENCLOSED STRUCTURE

DATE: 8-21-20

SCALE: NTS

JOB NO: 20172S

SHT. 6

DWG. NO: SK-3

REV: 0

THIS DOCUMENT IS THE PROPERTY OF MOORE AND ASSOCIATES ENGINEERING AND CONSULTING. THE UNAUTHORIZED REPRODUCTION, COPYING, OR OTHERWISE USE OF THIS DOCUMENT IS STRICTLY PROHIBITED AND ANY INFRINGEMENT THEREUPON MAY BE SUBJECT TO LEGAL ACTION.

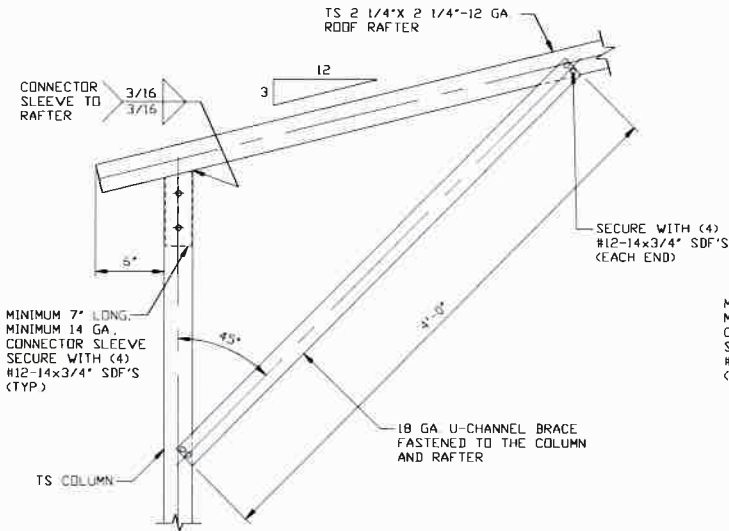

BOX EAVE RAFTER/CORNER POST CONNECTION DETAIL FOR HEIGHTS $\leq 11'-0''$

1B

SCALE: NTS

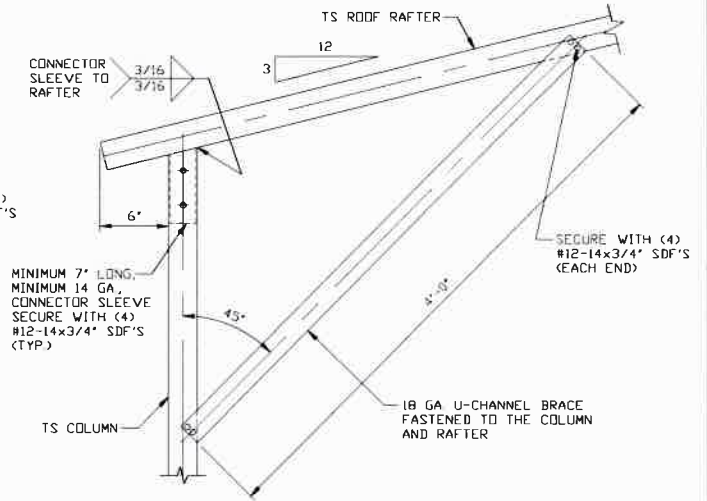

BOX EAVE RAFTER/CORNER POST CONNECTION DETAIL FOR HEIGHTS $\leq 11'-0''$

1C

SCALE: NTS

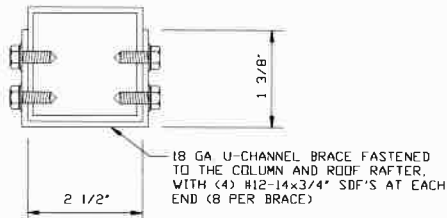

BRACE SECTION

SCALE: NTS

**MOORE AND ASSOCIATES
ENGINEERING AND CONSULTING, INC.**

DRAWN BY: JG

CHECKED BY: PDH

PROJECT MGR: WSH

CLIENT: DBA COWBOYS

DBA COWBOYS
1772 N. ANDY GRIFFITH PKWY
MT. AIRY, NC 27030
30'-0" x 16'-0" ENCLOSED STRUCTURE

DATE: 8-21-20

SHT. 6A

SCALE: NTS

DWG. NO: SK-3

JOB NO: 20172S

REV: 0

THIS DOCUMENT IS THE PROPERTY OF MOORE AND ASSOCIATES ENGINEERING AND CONSULTING. THE UNAUTHORIZED REPRODUCTION, COPYING, OR OTHERWISE USE OF THIS DOCUMENT IS STRICTLY PROHIBITED AND ANY INFRINGEMENT THEREUPON MAY BE SUBJECT TO LEGAL ACTION.

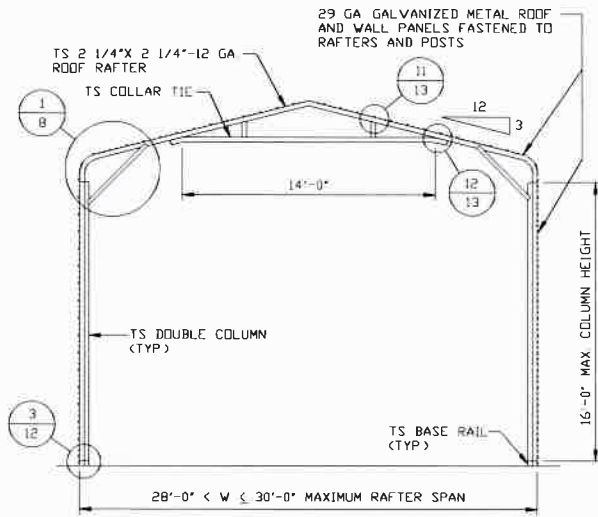

TYPICAL RAFTER/COLUMN FRAME SECTION
SCALE: NTS

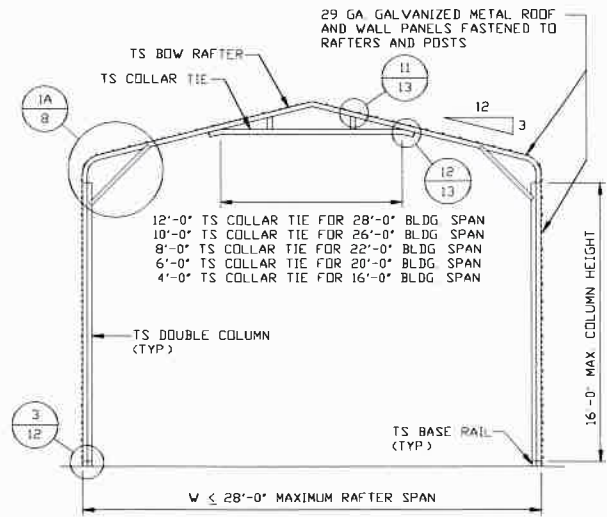

TYPICAL RAFTER/COLUMN FRAME SECTION
SCALE: NTS

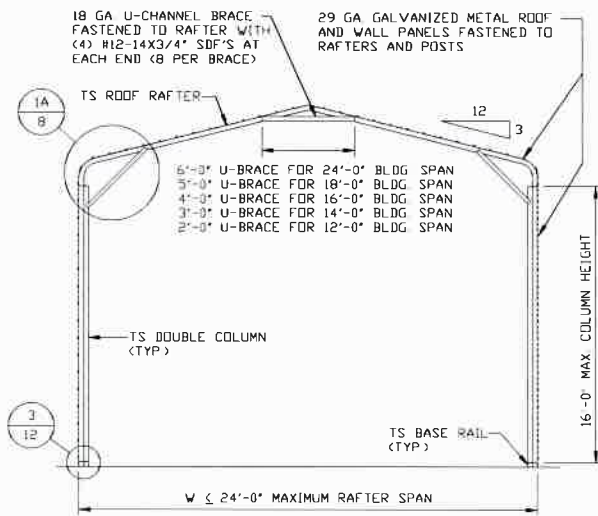

TYPICAL RAFTER/COLUMN FRAME SECTION
SCALE: NTS

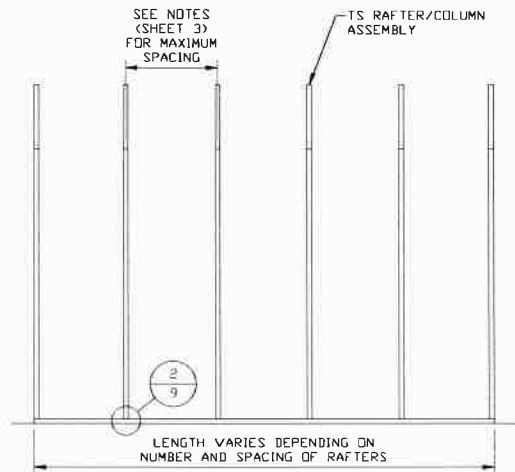

TYPICAL RAFTER/COLUMN SIDE FRAMING SECTION
SCALE: NTS

**MOORE AND ASSOCIATES
ENGINEERING AND CONSULTING, INC.**

DRAWN BY: JG

CHECKED BY: PDH

PROJECT MGR: WSM

CLIENT: DBA COWBOYS

**DBA COWBOYS
1772 N. ANDY GRIFFITH PKWY
MT. AIRY, NC 27030
30'-0"x16'-0" ENCLOSED STRUCTURE**

DATE: 8-21-20

SHT. 7

SCALE: NTS

DWG. NO: SK-3

JOB NO: 20172S

REV: 0

THIS DOCUMENT IS THE PROPERTY OF MOORE AND ASSOCIATES ENGINEERING AND CONSULTING. THE UNAUTHORIZED REPRODUCTION, COPYING, OR OTHERWISE USE OF THIS DOCUMENT IS STRICTLY PROHIBITED AND ANY INFRINGEMENT THEREUPON MAY BE SUBJECT TO LEGAL ACTION.

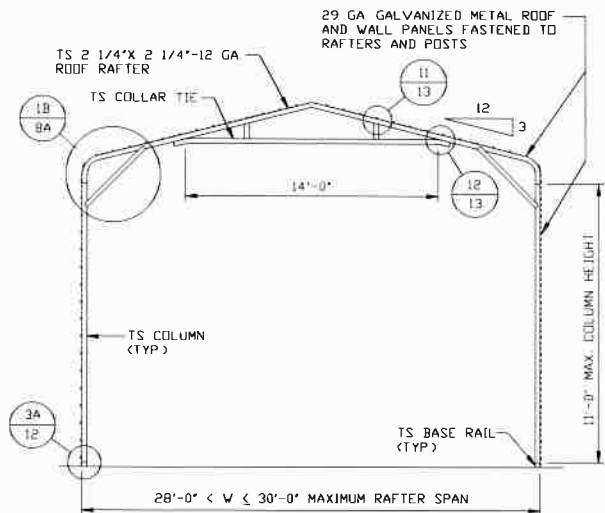

TYPICAL RAFTER/COLUMN FRAME SECTION
SCALE: NTS

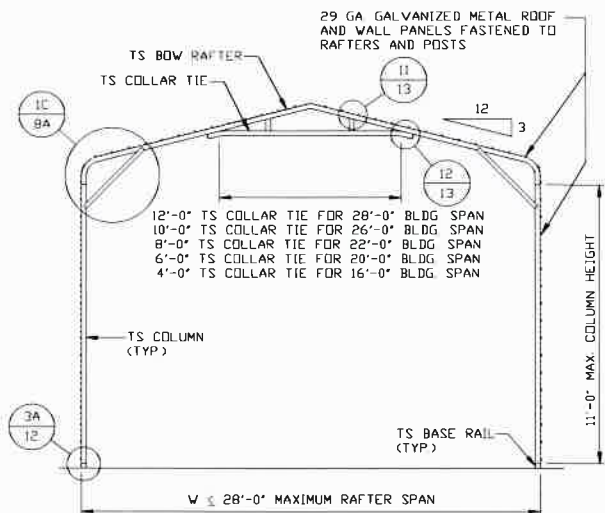

TYPICAL RAFTER/COLUMN FRAME SECTION
SCALE: NTS

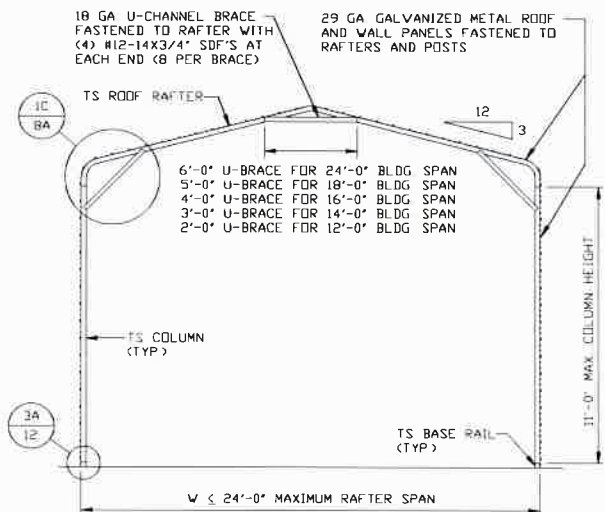

TYPICAL RAFTER/COLUMN FRAME SECTION
SCALE: NTS

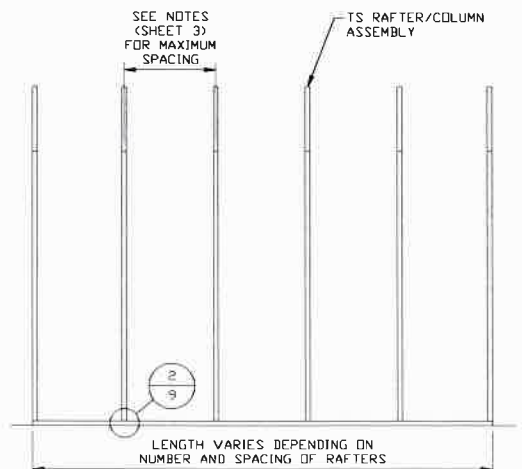

TYPICAL RAFTER/COLUMN SIDE FRAMING SECTION
SCALE: NTS

**MOORE AND ASSOCIATES
ENGINEERING AND CONSULTING, INC.**

DRAWN BY: JG CHECKED BY: PDH PROJECT MGR: WSM CLIENT: DBA COWBOYS	DATE: 8-21-20 SHT. 7A	DBA COWBOYS 1772 N. ANDY GRIFFITH PKWY MT. AIRY, NC 27030 30'-0"x16'-0" ENCLOSED STRUCTURE SCALE: NTS DWG. NO: SK-3	JOB NO: 20172S REV: 0
--	--------------------------	--	--------------------------

THIS DOCUMENT IS THE PROPERTY OF MOORE AND ASSOCIATES ENGINEERING AND CONSULTING. THE UNAUTHORIZED REPRODUCTION, COPYING, OR OTHERWISE USE OF THIS DOCUMENT IS STRICTLY PROHIBITED AND ANY INFRINGEMENT THEREUPON MAY BE SUBJECT TO LEGAL ACTION.

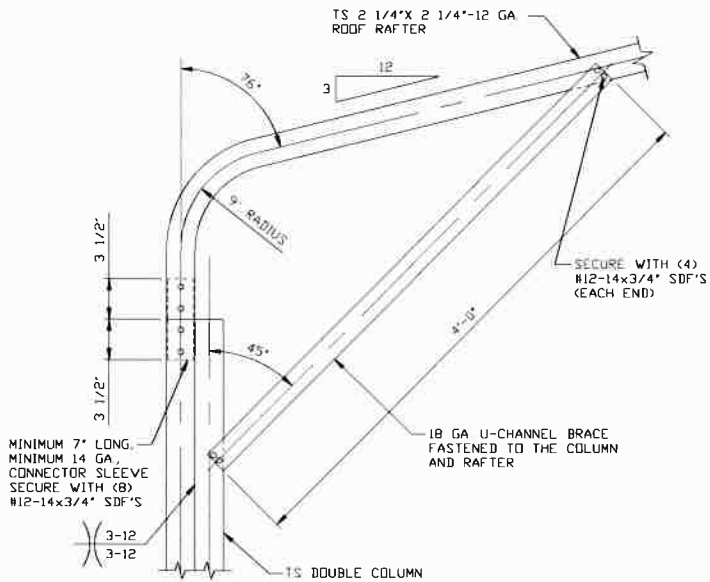

1
BOW EAVE RAFTER/CORNER POST CONNECTION DETAIL
FOR HEIGHTS 11'-0" < TO ≤ 16'-0"
 SCALE: NTS

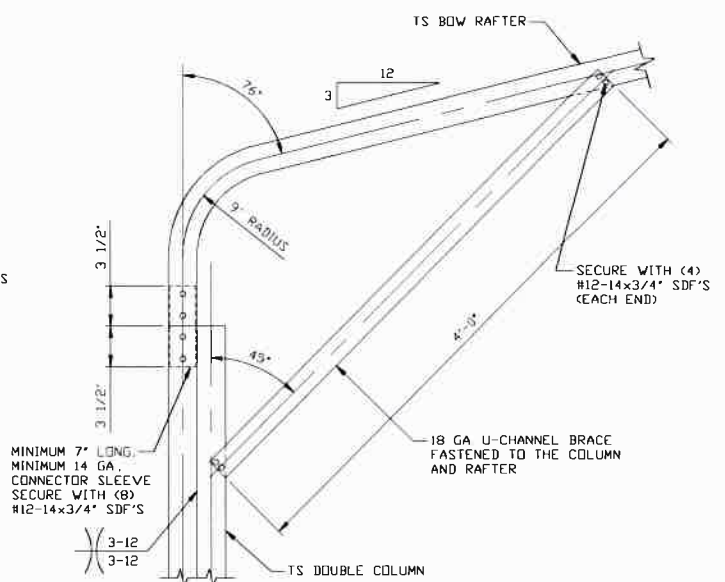

1A
BOW EAVE RAFTER/CORNER POST CONNECTION DETAIL
FOR HEIGHTS 11'-0" < TO ≤ 16'-0"
 SCALE: NTS

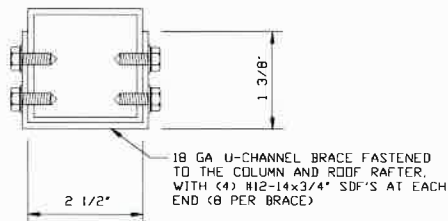

BRACE SECTION
 SCALE: NTS

MOORE AND ASSOCIATES
ENGINEERING AND CONSULTING, INC.

DRAWN BY: JG

CHECKED BY: PDH

PROJECT MGR: WSM

CLIENT: DBA COWBOYS

DBA COWBOYS
 1772 N. ANDY GRIFFITH PKWY
 MT. AIRY, NC 27030
 30'-0"x16'-0" ENCLOSED STRUCTURE

DATE: 8-21-20

SHT. 8

SCALE: NTS

DWG. NO: SK-3

JOB NO: 20172S

REV: 0

THIS DOCUMENT IS THE PROPERTY OF MOORE AND ASSOCIATES ENGINEERING AND CONSULTING. THE UNAUTHORIZED REPRODUCTION, COPYING, OR OTHERWISE USE OF THIS DOCUMENT IS STRICTLY PROHIBITED AND ANY INFRINGEMENT THEREUPON MAY BE SUBJECT TO LEGAL ACTION.

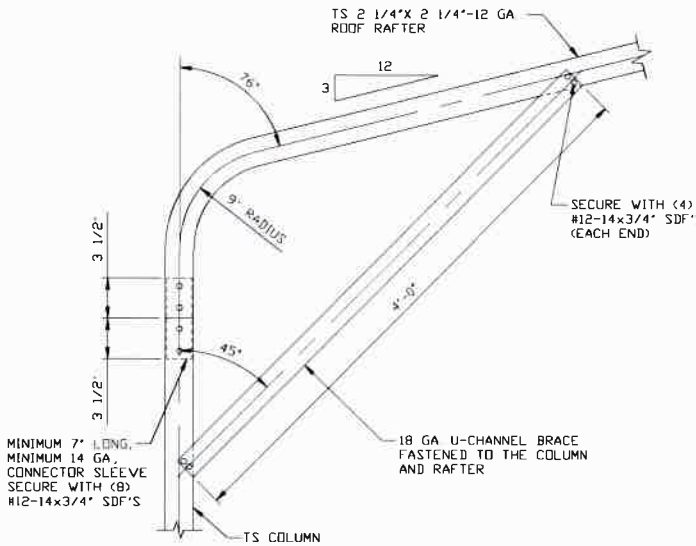

BOW EAVE RAFTER/CORNER POST CONNECTION DETAIL FOR HEIGHTS < 11'-0"

1B

SCALE: NTS

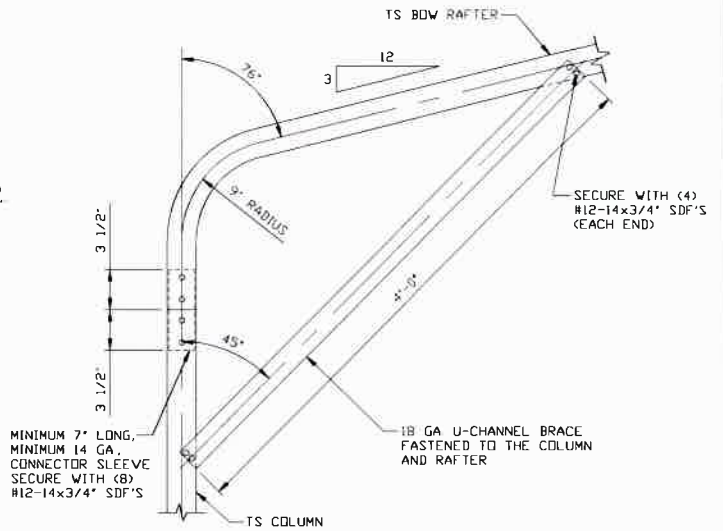

BOW EAVE RAFTER/CORNER POST CONNECTION DETAIL FOR HEIGHTS < 11'-0"

1C

SCALE: NTS

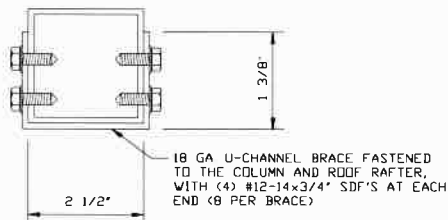

BRACE SECTION

SCALE: NTS

**MOORE AND ASSOCIATES
ENGINEERING AND CONSULTING, INC.**

DRAWN BY: JG

CHECKED BY: PDH

PROJECT MGR: WSM

CLIENT: DBA COWBOYS

DBA COWBOYS
1772 N. ANDY GRIFFITH PKWY
MT. AIRY, NC 27030
30'-0" X 16'-0" ENCLOSED STRUCTURE

DATE: 8-21-20

SHT. 8A

SCALE: NTS

DWG. NO: SK-3

JOB NO: 20172S

REV: 0

THIS DOCUMENT IS THE PROPERTY OF MOORE AND ASSOCIATES ENGINEERING AND CONSULTING. THE UNAUTHORIZED REPRODUCTION, COPYING, OR OTHERWISE USE OF THIS DOCUMENT IS STRICTLY PROHIBITED AND ANY INFRINGEMENT THEREUPON MAY BE SUBJECT TO LEGAL ACTION.

BASE RAIL ANCHORAGE OPTIONS

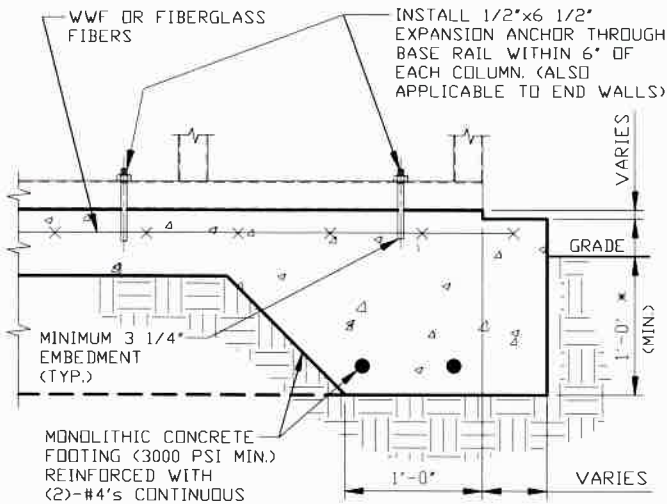

2

CONCRETE MONOLITHIC SLAB BASE RAIL ANCHORAGE

SCALE: NTS
MINIMUM ANCHOR EDGE DISTANCE IS 4"
* COORDINATE WITH LOCAL BUILDING CODE
AND/OR D REGARDING MINIMUM FROST DEPTH
(LENGTH)

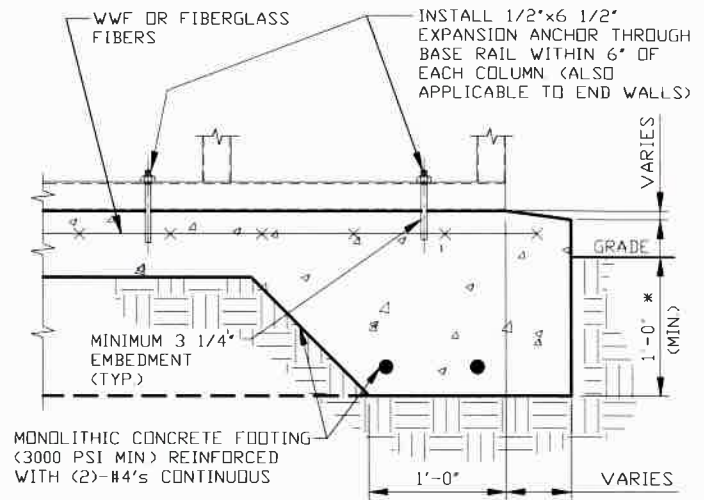

2A

CONCRETE SLAB BASE RAIL ANCHORAGE

SCALE: NTS
MINIMUM ANCHOR EDGE DISTANCE IS 4"
* COORDINATE WITH LOCAL BUILDING CODE
AND/OR D REGARDING MINIMUM FROST DEPTH
(LENGTH)

GENERAL NOTES

NOTE: CONCRETE MONOLITHIC SLAB DESIGN BASED ON MINIMUM SOIL BEARING CAPACITY OF 1,500 PSF

CONCRETE:

CONCRETE SHALL HAVE A MINIMUM SPECIFIED COMPRESSIVE STRENGTH OF 3,000 PSI AT 28 DAYS

COVER OVER REINFORCING STEEL:

FOR FOUNDATIONS, MINIMUM CONCRETE COVER OVER REINFORCING BARS SHALL BE PER ACI-318:
3" IN FOUNDATIONS WHERE THE CONCRETE IS CAST AGAINST AND PERMANENTLY IN CONTACT WITH THE EARTH OR EXPOSED TO THE EARTH OR WEATHER, AND 1 1/2" ELSEWHERE.

REINFORCING STEEL:

THE TURNDOWN REINFORCING STEEL SHALL BE ASTM A615 GRADE 60. THE SLAB REINFORCEMENT SHALL BE WELDED WIRE FABRIC MEETING ASTM A185 OR FIBERGLASS FIBER REINFORCEMENT.

REINFORCEMENT MAY BE BENT IN THE SHOP OR THE FIELD PROVIDED:

1. REINFORCEMENT IS BENT COLD.
2. THE DIAMETER OF THE BEND, MEASURED ON THE INSIDE OF THE BAR, IS NOT LESS THAN SIX-BAR DIAMETERS.
3. REINFORCEMENT PARTIALLY EMBEDDED IN CONCRETE SHALL NOT BE FIELD BENT.

HELIX ANCHOR NOTES:

1. FOR VERY DENSE AND/OR CEMENTED SANDS, COARSE GRAVEL AND COBBLES, CALICHE, PRELOADED SILTS AND CLAYS, USE MINIMUM (2) 4" HELICES WITH MINIMUM 30" EMBEDMENT OR SINGLE 6" HELIX WITH MINIMUM 50" EMBEDMENT.
2. FOR CORAL USE MINIMUM (2) 4" HELICES WITH MINIMUM 30" EMBEDMENT OR SINGLE 6" HELIX WITH MINIMUM 50" EMBEDMENT.
3. FOR MEDIUM DENSE COARSE SANDS, SANDY GRAVELS, VERY STIFF SILTS, AND CLAYS USE MINIMUM (2) 4" HELICES WITH MINIMUM 30 INCH EMBEDMENT OR SINGLE 6" HELIX WITH MINIMUM 50" EMBEDMENT.
4. FOR LOOSE TO MEDIUM DENSE SANDS, FIRM TO STIFF CLAYS AND SILTS ALLUVIAL FILL, USE MINIMUM (2) 6" HELICES WITH MINIMUM 50" EMBEDMENT.
5. FOR VERY LOOSE TO MEDIUM DENSE SANDS, FIRM TO STIFFER CLAYS AND SILTS, ALLUVIAL FILL, USE MINIMUM (2) 8" HELICES WITH MINIMUM 50" EMBEDMENT.

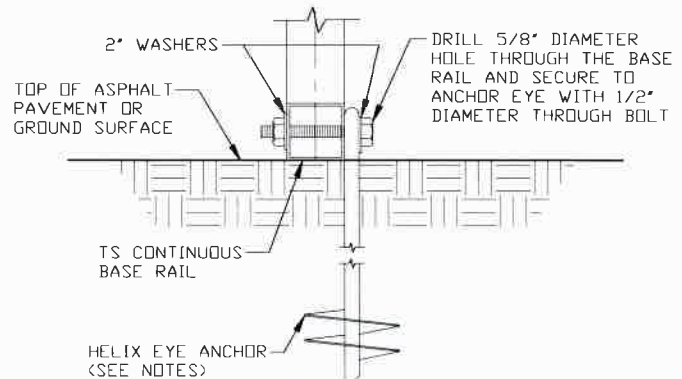

2B

GROUND BASE HELIX ANCHORAGE

SCALE: NTS
(CAN BE USED FOR ASPHALT)
* COORDINATE WITH LOCAL BUILDING CODE AND/OR D REGARDING MINIMUM FROST DEPTH (LENGTH)

**MOORE AND ASSOCIATES
ENGINEERING AND CONSULTING, INC.**

DRAWN BY: JG

CHECKED BY: PDH

PROJECT MGR: VSM

CLIENT: DBA COWBOYS

DBA COWBOYS
1772 N. ANDY GRIFFITH PKWY
MT. AIRY, NC 27030
30'-0"x16'-0" ENCLOSED STRUCTURE

DATE: 8-21-20

SHT. 9

SCALE: NTS

DWG. NO: SK-3

JOB NO: 20172S

REV: 0

THIS DOCUMENT IS THE PROPERTY OF MOORE AND ASSOCIATES ENGINEERING AND CONSULTING. THE UNAUTHORIZED REPRODUCTION, COPYING, OR OTHERWISE USE OF THIS DOCUMENT IS STRICTLY PROHIBITED AND ANY INFRINGEMENT THEREUPON MAY BE SUBJECT TO LEGAL ACTION.

BOX EAVE RAFTER END WALL AND SIDE WALL OPENINGS

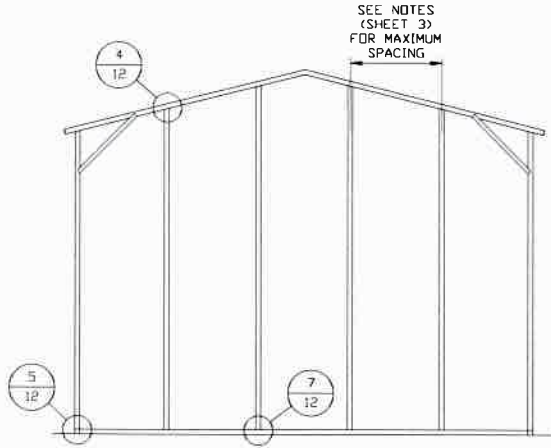

**TYPICAL BOX EAVE RAFTER
END WALL FRAMING SECTION**

SCALE: NTS

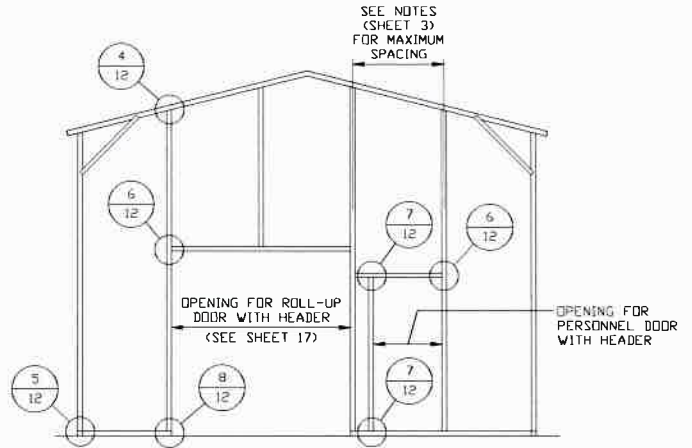

**TYPICAL BOX EAVE RAFTER END
WALL OPENINGS FRAMING SECTION**

SCALE: NTS

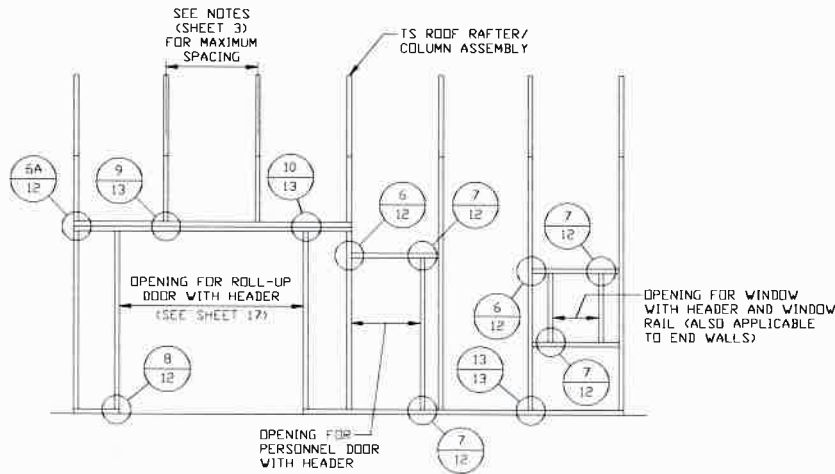

**TYPICAL BOX EAVE RAFTER
SIDE WALL OPENINGS FRAMING SECTION**

SCALE: NTS

**MOORE AND ASSOCIATES
ENGINEERING AND CONSULTING, INC.**

DRAWN BY: JG

CHECKED BY: PDH

PROJECT MGR: WSM

CLIENT: DBA COWBOYS

DBA COWBOYS
1772 N. ANDY GRIFFITH PKWY
MT. AIRY, NC 27030
30'-0" x 16'-0" ENCLOSED STRUCTURE

DATE: 8-21-20

SHT. 10

SCALE: NTS

DWG. NO: SK-3

JOB NO: 20172S

REV: 0

THIS DOCUMENT IS THE PROPERTY OF MOORE AND ASSOCIATES ENGINEERING AND CONSULTING. THE UNAUTHORIZED REPRODUCTION, COPYING, OR OTHERWISE USE OF THIS DOCUMENT IS STRICTLY PROHIBITED AND ANY INFRINGEMENT THEREUPON MAY BE SUBJECT TO LEGAL ACTION.

BOW EAVE RAFTER END WALL AND SIDE WALL OPENINGS

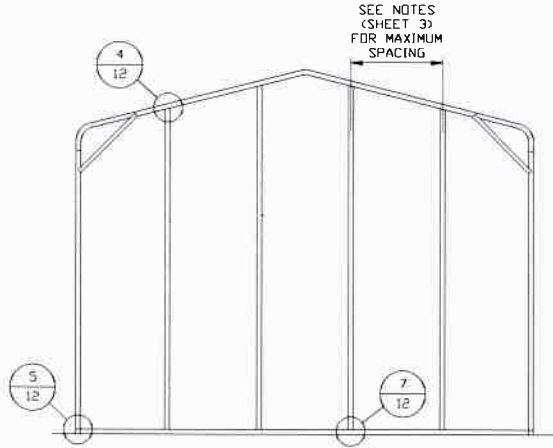

**TYPICAL BOW EAVE RAFTER
END WALL FRAMING SECTION**

SCALE: NTS

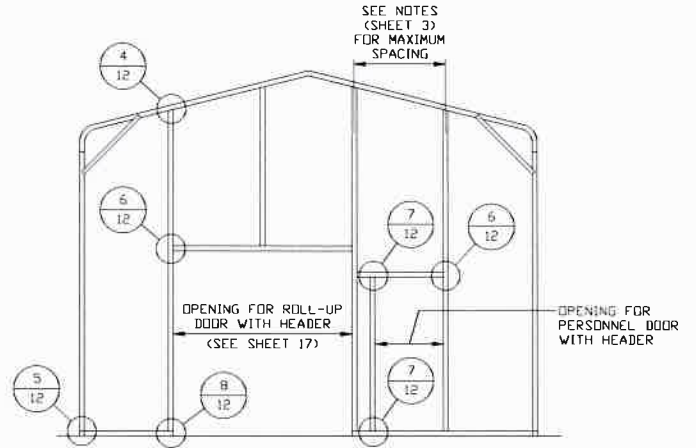

**TYPICAL BOW EAVE RAFTER END
WALL OPENINGS FRAMING SECTION**

SCALE: NTS

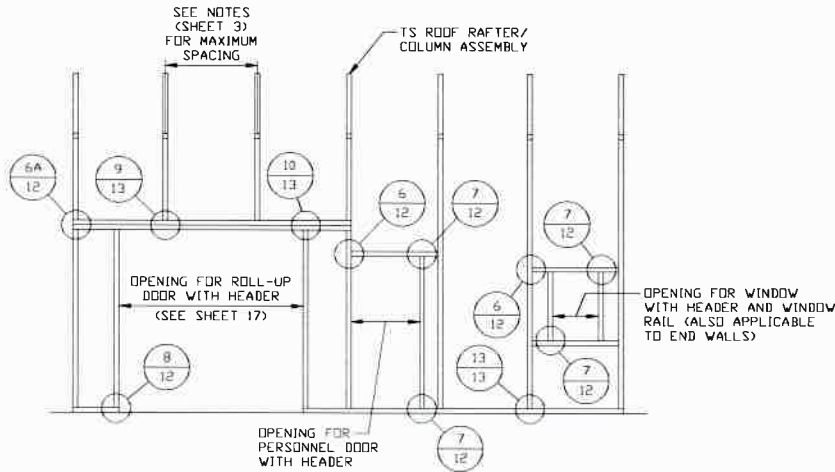

**TYPICAL BOW EAVE RAFTER
SIDE WALL OPENINGS FRAMING SECTION**

SCALE: NTS

**MOORE AND ASSOCIATES
ENGINEERING AND CONSULTING, INC.**

DRAWN BY: JG

CHECKED BY: PDH

PROJECT MGR: WSM

CLIENT: DBA COWBOYS

DBA COWBOYS
1772 N. ANDY GRIFFITH PKWY
MT. AIRY, NC 27030
30'-0" x 16'-0" ENCLOSED STRUCTURE

DATE: 8-21-20

SHT. 11

SCALE: NTS

DWG. NO: SK-3

JOB NO: 20172S

REV: 0

THIS DOCUMENT IS THE PROPERTY OF MOORE AND ASSOCIATES ENGINEERING AND CONSULTING. THE UNAUTHORIZED REPRODUCTION, COPYING, OR OTHERWISE USE OF THIS DOCUMENT IS STRICTLY PROHIBITED AND ANY INFRINGEMENT THEREUPON MAY BE SUBJECT TO LEGAL ACTION.

CONNECTION DETAILS

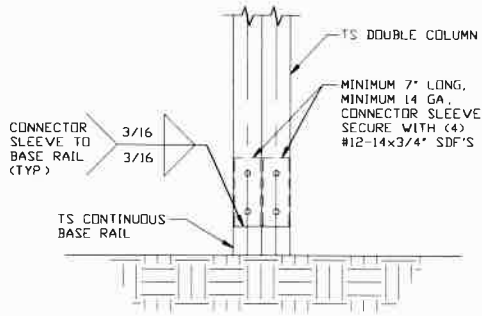

3 **POST/BASE RAIL CONNECTION DETAIL**
SCALE: NTS

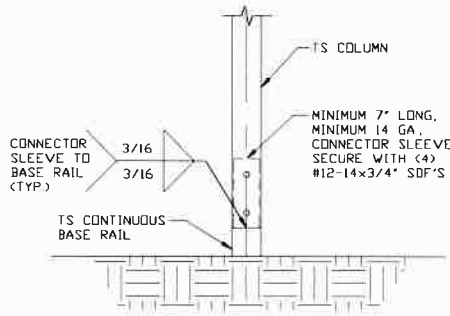

3A **POST/BASE RAIL CONNECTION DETAIL**
SCALE: NTS

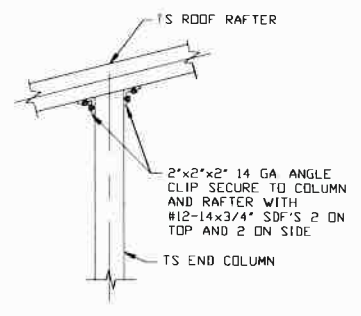

4 **END COLUMN/RAFTER CONNECTION DETAIL**
SCALE: NTS

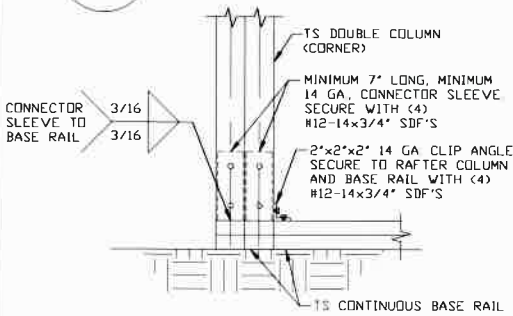

5 **END COLUMN/BASE RAIL CONNECTION DETAIL**
SCALE: NTS

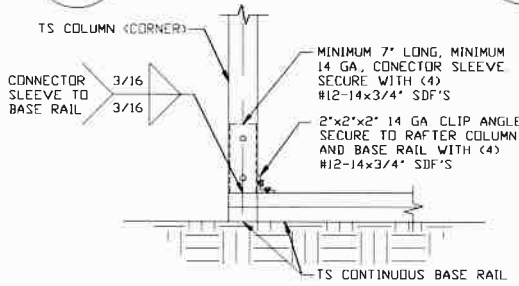

5A **END COLUMN/BASE RAIL CONNECTION DETAIL**
SCALE: NTS

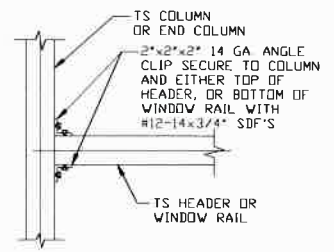

6 **COLUMN OR WINDOW RAIL/WALL GIRTS TO POST CONNECTION DETAIL**
SCALE: NTS

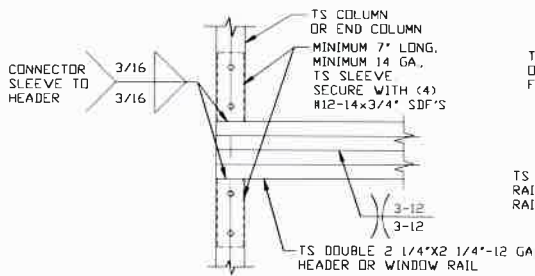

6A **COLUMN OR WINDOW RAIL TO POST CONNECTION DETAIL**
SCALE: NTS

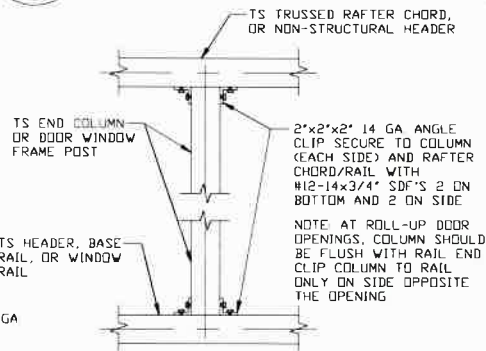

7 **COLUMN TO HEADER, BASE RAIL, OR WINDOW RAIL CONNECTION DETAIL**
SCALE: NTS

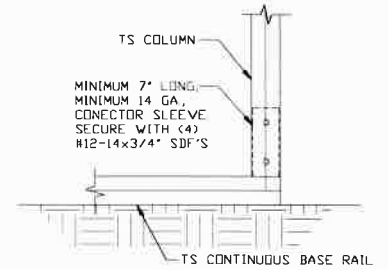

8 **COLUMN/BASE RAIL CONNECTION DETAIL**
SCALE: NTS

MOORE AND ASSOCIATES ENGINEERING AND CONSULTING, INC.

DRAWN BY: JG
CHECKED BY: PDH

DBA COWBOYS
1772 N. ANDY GRIFFITH PKWY
MT. AIRY, NC 27030
30'-0"x16'-0" ENCLOSED STRUCTURE

THIS DOCUMENT IS THE PROPERTY OF MOORE AND ASSOCIATES ENGINEERING AND CONSULTING. THE UNAUTHORIZED REPRODUCTION, COPYING, OR OTHERWISE USE OF THIS DOCUMENT IS STRICTLY PROHIBITED AND ANY INFRINGEMENT THEREUPON MAY BE SUBJECT TO LEGAL ACTION.

PROJECT MGR: WSM **DATE: 8-21-20** **SCALE: NTS** **JOB NO: 20172S**
CLIENT: DBA COWBOYS **SHT. 12** **DWG. NO: SK-3** **REV: 0**

CONNECTION DETAILS

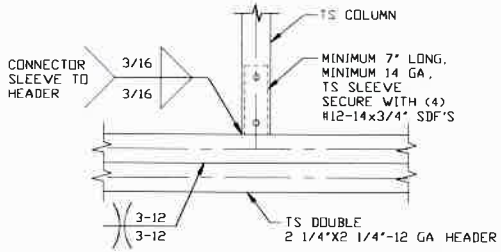

9 COLUMN/DOUBLE HEADER CONNECTION DETAIL
SCALE: NTS

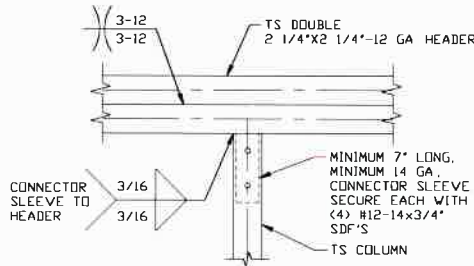

10 DOUBLE HEADER/COLUMN CONNECTION DETAIL
SCALE: NTS

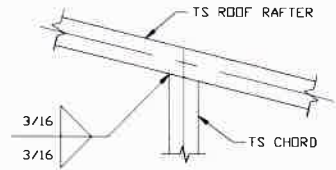

11 RAFTER TO CHORD CONNECTION DETAIL
SCALE: NTS

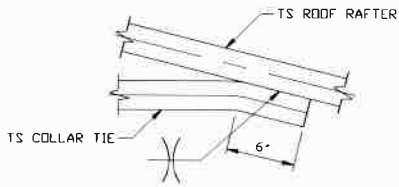

12 COLLAR TIE CONNECTION DETAIL
SCALE: NTS

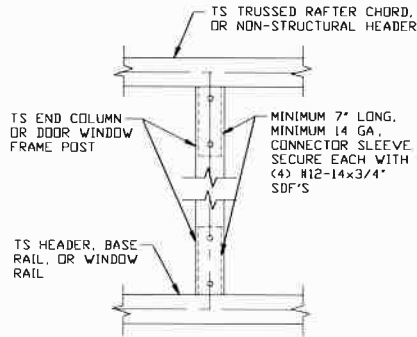

13 COLUMN TO HEADER OR BASE RAIL CONNECTION DETAIL
SCALE: NTS

**MOORE AND ASSOCIATES
ENGINEERING AND CONSULTING, INC.**

DRAWN BY: JG

CHECKED BY: PDH

PROJECT MGR: WSM

CLIENT: DBA COWBOYS

**DBA COWBOYS
1772 N. ANDY GRIFFITH PKWY
MT. AIRY, NC 27030
30'-0" x 16'-0" ENCLOSED STRUCTURE**

DATE: 8-21-20

SCALE: NTS

JOB NO: 20172S

SHT. 13

DWG. NO: SK-3

REV: 0

THIS DOCUMENT IS THE PROPERTY OF MOORE AND ASSOCIATES ENGINEERING AND CONSULTING. THE UNAUTHORIZED REPRODUCTION, COPYING, OR OTHERWISE USE OF THIS DOCUMENT IS STRICTLY PROHIBITED AND ANY INFRINGEMENT THEREUPON MAY BE SUBJECT TO LEGAL ACTION.

BOX EAVE RAFTER LEAN-TO OPTIONS

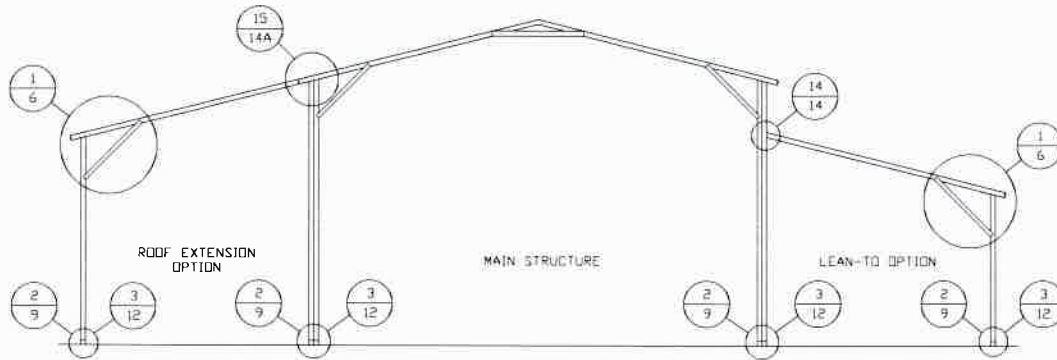

TYPICAL BOX EAVE RAFTER LEAN-TO OPTIONS FRAMING SECTION (BOTH OPTIONS SHOWN)

SCALE: NTS

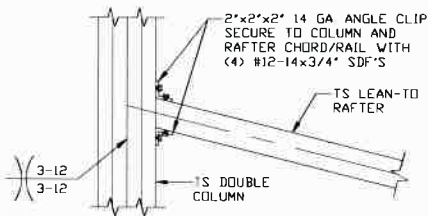

**LEAN-TO RAFTER TO RAFTER
COLUMN CONNECTION DETAIL
FOR RAFTER SPANS $\leq 11'-0"$**

14

SCALE: NTS

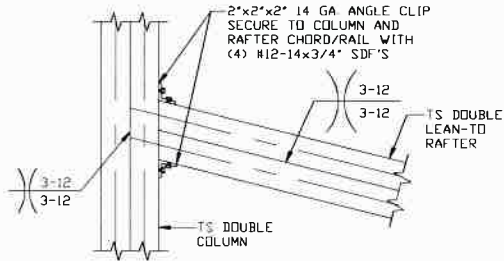

**LEAN-TO RAFTER TO RAFTER
COLUMN CONNECTION DETAIL FOR
RAFTER SPANS $11'-0" < \text{TO} \leq 12'-0"$**

14A

SCALE: NTS

**MOORE AND ASSOCIATES
ENGINEERING AND CONSULTING, INC.**

DRAWN BY: JG

CHECKED BY: PDH

PROJECT MGR: WSM

CLIENT: DBA COWBOYS

DBA COWBOYS
1772 N. ANDY GRIFFITH PKWY
MT. AIRY, NC 27030
30'-0" x 16'-0" ENCLOSED STRUCTURE

DATE: 8-21-20

SCALE: NTS

JOB NO: 20172S

SHT. 14

DWG. NO: SK-3

REV: 0

THIS DOCUMENT IS THE PROPERTY OF MOORE AND ASSOCIATES ENGINEERING AND CONSULTING. THE UNAUTHORIZED REPRODUCTION, COPYING, OR OTHERWISE USE OF THIS DOCUMENT IS STRICTLY PROHIBITED AND ANY INFRINGEMENT THEREUPON MAY BE SUBJECT TO LEGAL ACTION.

BOX EAVE RAFTER LEAN-TO OPTIONS

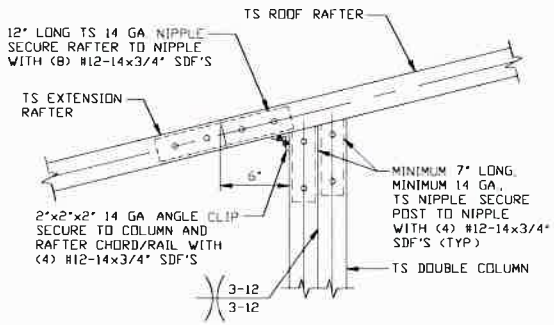

15 SIDE EXTENSION RAFTER/COLUMN
DETAIL FOR SPANS $\leq 11'-0"$

SCALE: NTS

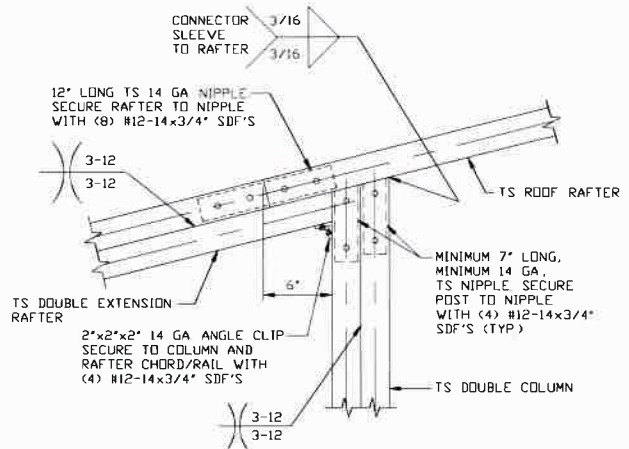

15A SIDE EXTENSION RAFTER/COLUMN
DETAIL FOR SPANS $11'-0" < TO \leq 12'-0"$

SCALE: NTS

**MOORE AND ASSOCIATES
ENGINEERING AND CONSULTING, INC.**

DRAWN BY: JG

CHECKED BY: PDH

PROJECT MGR: WSM

CLIENT: DBA COWBOYS

**DBA COWBOYS
1772 N. ANDY GRIFFITH PKWY
MT. AIRY, NC 27030
30'-0"x16'-0" ENCLOSED STRUCTURE**

DATE: 8-21-20

SCALE: NTS

JOB NO: 20172S

SHT. 14A

DWG. NO: SK-3

REV: 0

THIS DOCUMENT IS THE PROPERTY OF MOORE AND ASSOCIATES ENGINEERING AND CONSULTING. THE UNAUTHORIZED REPRODUCTION, COPYING, OR OTHERWISE USE OF THIS DOCUMENT IS STRICTLY PROHIBITED AND ANY INFRINGEMENT THEREUPON MAY BE SUBJECT TO LEGAL ACTION.

BOW EAVE RAFTER LEAN-TO OPTIONS

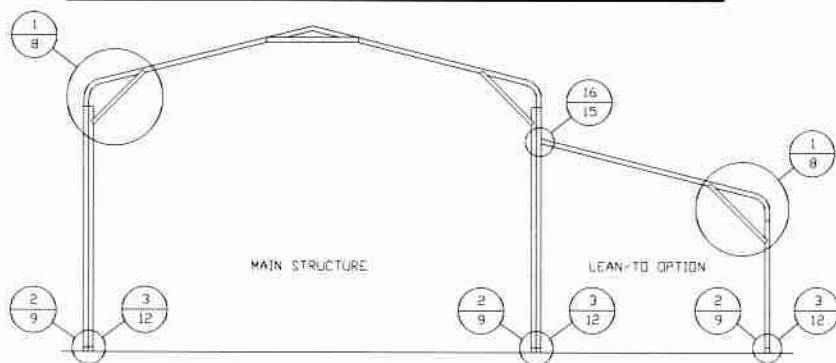

TYPICAL BOW EAVE RAFTER LEAN-TO OPTIONS FRAMING SECTION

SCALE: NTS

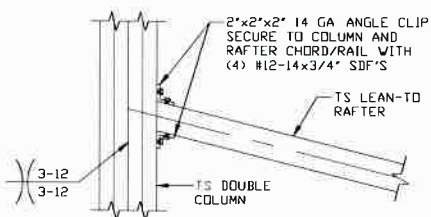

LEAN-TO RAFTER TO RAFTER COLUMN CONNECTION DETAIL FOR RAFTER SPANS $\leq 11'-0''$

SCALE: NTS

16

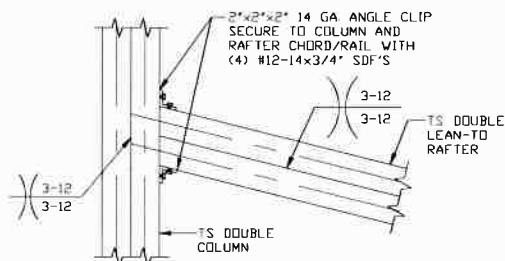

LEAN-TO RAFTER TO RAFTER COLUMN CONNECTION DETAIL FOR RAFTER SPANS $11'-0'' < TO \leq 12'-0''$

SCALE: NTS

16A

**MOORE AND ASSOCIATES
ENGINEERING AND CONSULTING, INC.**

DRAWN BY: JG

CHECKED BY: PDH

PROJECT MGR: WSM

CLIENT: DBA COWBOYS

DBA COWBOYS
1772 N. ANDY GRIFFITH PKWY
MT. AIRY, NC 27030
30'-0" x 16'-0" ENCLOSED STRUCTURE

DATE: 8-21-20

SHT. 15

SCALE: NTS

DWG. NO: SK-3

JOB NO: 20172S

REV: 0

THIS DOCUMENT IS THE PROPERTY OF MOORE AND ASSOCIATES ENGINEERING AND CONSULTING. THE UNAUTHORIZED REPRODUCTION, COPYING, OR OTHERWISE USE OF THIS DOCUMENT IS STRICTLY PROHIBITED AND ANY INFRINGEMENT THEREUPON MAY BE SUBJECT TO LEGAL ACTION.

BOX EAVE RAFTER VERTICAL ROOF/SIDING OPTION

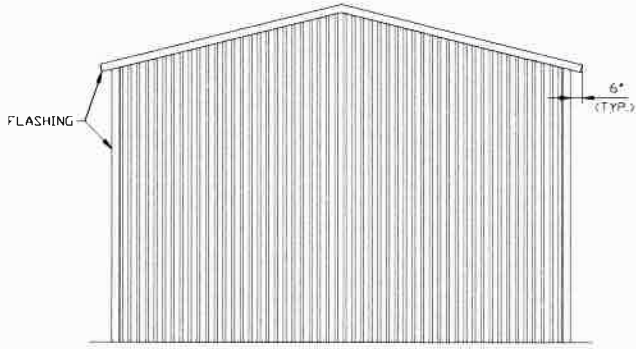

**TYPICAL END ELEVATION
VERTICAL ROOF/SIDING**
SCALE: NTS

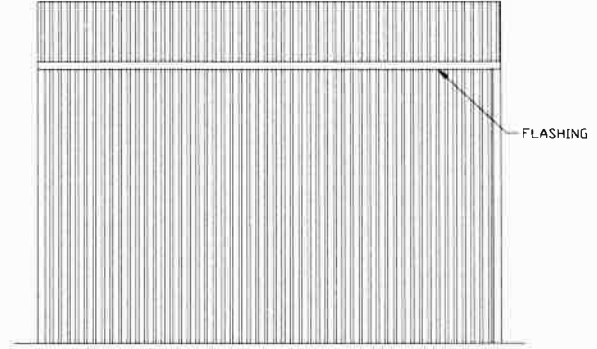

**TYPICAL SIDE ELEVATION
VERTICAL ROOF/SIDING**
SCALE: NTS

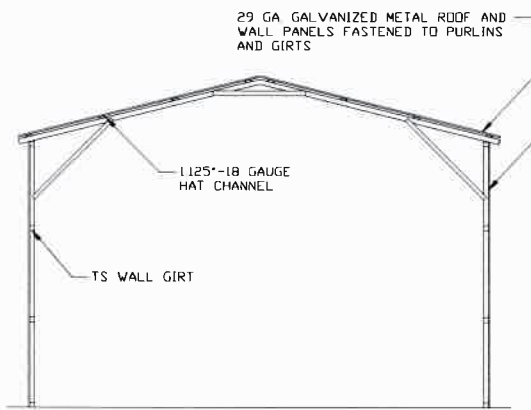

**TYPICAL SECTION VERTICAL
ROOF/SIDING OPTION**
SCALE: NTS

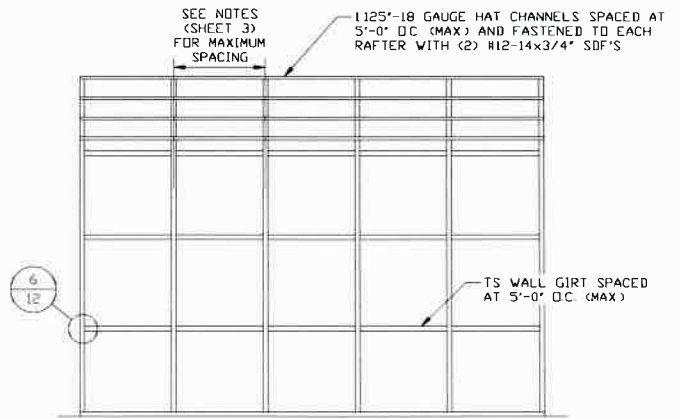

**TYPICAL FRAMING SECTION VERTICAL
ROOF/SIDING OPTION WITH TS GIRTS**
SCALE: NTS

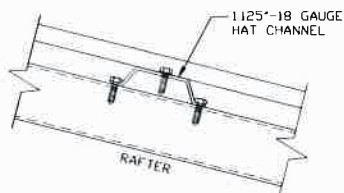

PANEL ATTACHMENT
(ALTERNATE FOR VERTICAL ROOF PANELS)
SCALE: NTS

**MOORE AND ASSOCIATES
ENGINEERING AND CONSULTING, INC.**

DRAWN BY: JG
CHECKED BY: PDH

DBA COWBOYS
1772 N. ANDY GRIFFITH PKWY
MT. AIRY, NC 27030
30'-0" x 16'-0" ENCLOSED STRUCTURE

THIS DOCUMENT IS THE PROPERTY OF MOORE AND ASSOCIATES ENGINEERING AND CONSULTING. THE UNAUTHORIZED REPRODUCTION, COPYING, OR OTHERWISE USE OF THIS DOCUMENT IS STRICTLY PROHIBITED AND ANY INFRINGEMENT THEREUPON MAY BE SUBJECT TO LEGAL ACTION.

PROJECT MGR: WSM	DATE: 8-21-20	SCALE: NTS	JOB NO: 20172S
CLIENT: DBA COWBOYS	SHT. 16	DWG. NO: SK-3	REV: 0

SIDE WALL HEADER OPTIONS

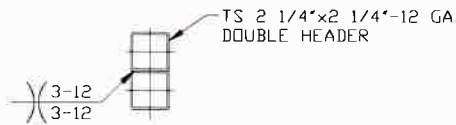

**HEADER DETAIL FOR SIDE WALL
DOOR OPENINGS
6'-0" < LENGTH ≤ 12'-0"**

SCALE: NTS

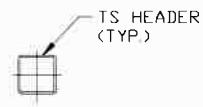

**HEADER DETAIL FOR SIDE WALL
DOOR OPENINGS ≤ 6'-0"**

SCALE: NTS

END WALL HEADER OPTIONS

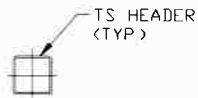

**HEADER DETAIL FOR END WALL
DOOR OPENINGS ≤ 12'-0"**

SCALE: NTS

**MOORE AND ASSOCIATES
ENGINEERING AND CONSULTING, INC.**

DRAWN BY: JG

CHECKED BY: PDH

PROJECT MGR: WSM

CLIENT: DBA COWBOYS

DBA COWBOYS
1772 N. ANDY GRIFFITH PKWY
MT. AIRY, NC 27030
30'-0"x16'-0" ENCLOSED STRUCTURE

DATE: 8-21-20

SCALE: NTS

JOB NO: 20172S

SHT. 17

DWG. NO: SK-3

REV: 0

THIS DOCUMENT IS THE PROPERTY OF MOORE AND ASSOCIATES ENGINEERING AND CONSULTING. THE UNAUTHORIZED REPRODUCTION, COPYING, OR OTHERWISE USE OF THIS DOCUMENT IS STRICTLY PROHIBITED AND ANY INFRINGEMENT THEREUPON MAY BE SUBJECT TO LEGAL ACTION.