



July 5 2022

Joyce Bennett
447 Deanne Lane
Coats, NC 27521
Email: jbennett@gmail.com

Reference: Engineering Services
447 Deanne Lane
Coats, NC 27521
TE&D Project No.: 1901-020458_A

To Whom It May Concern;

As requested by the client, a representative of Tyndall Engineering & Design, PA (TE&D) was on-site to provide analysis for the following item(s):

- 1) Structural assessment of the first-floor framing within the crawlspace.

The following conclusions and recommendations were noted:

- 1) The structural components of the crawlspace framing were inspected and evidence of wood destroying insect damage was observed throughout. The framing was spot checked with a probe to determine the extent of the damage. Based on our observations and analysis, a majority of the framing remains structurally suitable despite insect damage. All framing members are to be thoroughly treated to prevent future moisture damage and damage that may be caused by wood destroying insects. The following framing items are to be repaired:
 - A) Eight (8) 2 x 8 joists were observed to have been previously damaged by wood destroying insects. New, treated 2 x 8 joists are to be "sistered" to all damaged joists with (2) rows of 10D nails at 16" o.c. New joists are to have full bearing at each end. (see plan for joist locations)
 - B) Approximately 13'-0" of the 2 x 8 band at the rear of the house was observed to be damaged. Based on our observations and analysis, the band is to be reinforced with 2 x 10 blocking installed vertically at 16" o.c. Blocking is to be secured to the exterior deck band with 5/8" diameter through bolts. A (2) 2 x 8 header is to be installed over the crawlspace opening.
 - C) The existing band at the right of the house was observed to be notched in (2) locations. New 2 x 4 blocking is to be installed on each side of the notches and secured to the band with (2) rows of 10D nails at 4" o.c.
 - D) The existing band at the front of the house was observed to not fully bear on the foundation wall. A new, treated bottom plate is to be installed tightly between the top of the foundation and the bottom of the band. The new bottom plate is to be secured to the existing band with (1) row of 10D "toenails" at 4" o.c. The new plate may be notched or cut to accommodate existing anchor bolts.
 - E) We observed joists not fully bearing at the second girder from the right and the fourth girder from the right. TE&D recommends securing all affected joists to the girders with Simpson LUS28 face mount hangers (or equivalent) installed per the manufacturer's specifications.
 - F) An unsupported splice was observed in the second girder from the right. A new 8 x 16 CMU block pier is to be installed below the splice. The new pier is to have full bearing on a new, minimum 12" x 20" x 10" poured concrete footing. (see plan for location and detail A for installation)



Upon completion, the repairs above will provide adequate support for the anticipated loading conditions. We appreciate being able to assist you during this phase of the project. If you need further assistance or require additional information, please do not hesitate to contact us.

Sincerely,
Tyndall Engineering & Design

Tripp Amos
BH | 1901-020458_A

Prentice Tyndall Jr., P.E.





Item #1B:
Install 2 x 10 Blocking at 16" o.c.

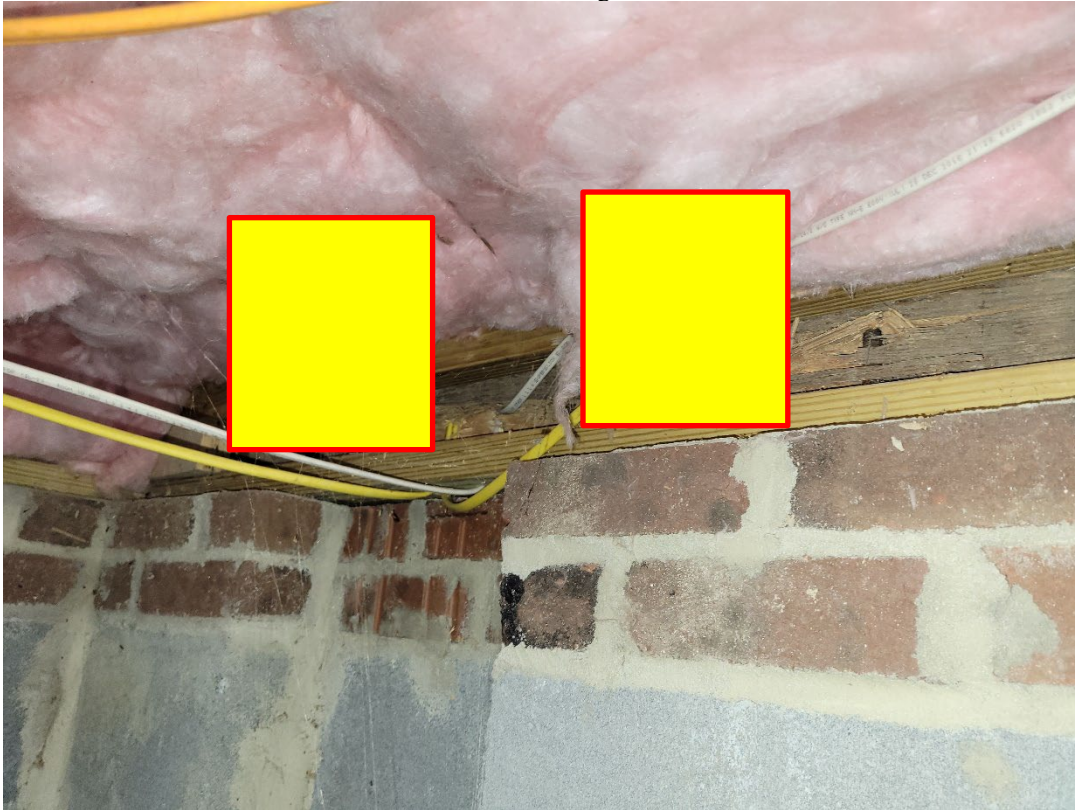

Install (2) 2 x 8 header over crawl opening



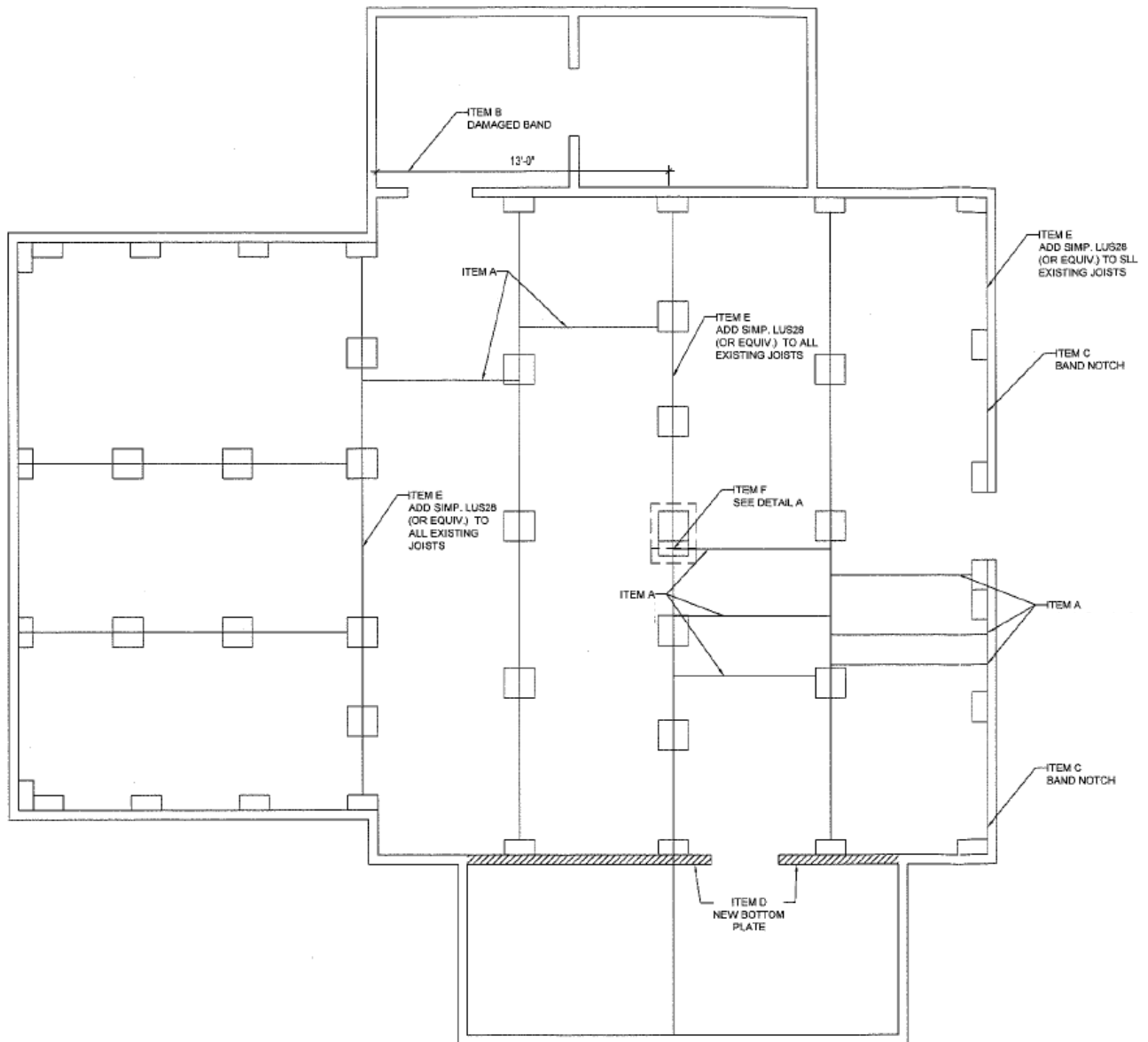

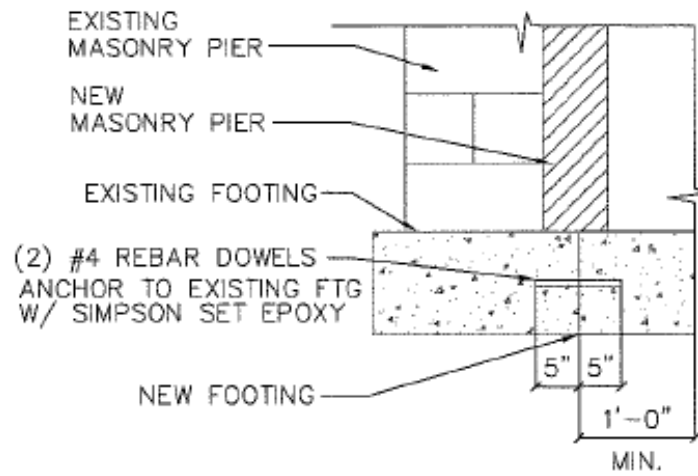

NTS  DETAIL "A"