

STUDIO SHED
 1500 CHERRY ST STE S
 LOUISVILLE, CO 80027
 888.900.3933

SUBMITTAL DOCUMENTS

JOB #:

PROJECT NAME:
EVANS

PROJECT LOCATION:
BROADWAY, NC (CHAPEL HILL)

SIGNATURE:

DATE:

20x50 LP

1

CONCRETE SLAB GENERAL NOTES:

FOUNDATIONS ARE DESIGNED WITHOUT AN ENGINEER'S SOIL INVESTIGATION. THE DESIGN CRITERIA IS ASSUMED FOR PURPOSES OF FOUNDATION DESIGN.

FOOTINGS:

DESIGN OF FOOTINGS IS BASED ON MAXIMUM ALLOWABLE BEARING PRESSURE: **1500 PSF** BEAR ON THE NATURAL UNDISTURBED SOIL OR COMPACTED STRUCTURAL FILL.

REINFORCED CONCRETE:

DESIGN IS BASED ON ACI 318 "BUILDING CODE REQUIREMENTS FOR STRUCTURAL CONCRETE" AND ACI 332 "REQUIREMENTS FOR RESIDENTIAL CONCRETE CONSTRUCTION." CONCRETE WORK SHALL CONFORM TO ACI 301 "STANDARD SPECIFICATIONS FOR STRUCTURAL CONCRETE."

STRUCTURAL CONCRETE SHALL HAVE THE FOLLOWING PROPERTIES:

| | F'C, PSI | MAX W/C RATIO | MAXIMUM AGGREGATE | SLUMP, INCHES (+/- 1") | ENTRAINED AIR, PERCENT (+/- 1.5%) | CEMENT TYPE | ADMIXTURES, COMMENTS |
|-------------------------------|-----------------|---------------------|----------------------|------------------------------|---|----------------|-------------------------|
| INTENDED USE SLAB ON GRADE | 28 DAY 2,500 | 0.45 | 3/4" STONE | 4 | 3 | I/II | |

DETAILING, FABRICATION, AND PLACEMENT OF REINFORCING STEEL SHALL BE IN ACCORDANCE WITH ACI 315-5 "DETAILS AND DETAILING OF CONCRETE REINFORCEMENT."

REINFORCING BARS SHALL CONFORM TO ASTM A615-04A, GRADE 60, EXCEPT TIES OR BARS SHOWN TO BE FIELD-BENT, WHICH SHALL BE GRADE 40.

BARS TO BE WELDED SHALL CONFORM TO ASTM 706-04A.

EXCEPT AS NOTED ON THE DRAWINGS, CONCRETE PROTECTION FOR REINFORCEMENT IN CAST-IN-PLACE CONCRETE SHALL BE AS FOLLOWS:

| | |
|---|---------------|
| CAST AGAINST AND PERMANENTLY EXPOSED TO EARTH: | 3" |
| EXPOSED TO EARTH OR WEATHER: | |
| #6 THROUGH #18 BARS: | 2" |
| #5 BAR, W31 OR D31 WIRE, AND SMALLER: | 1-1/2" |
| NOT EXPOSED TO WEATHER OR IN CONTACT WITH GROUND: | |
| SLABS, WALLS, JOISTS: #11 BARS AND SMALLER: | 3/4" |

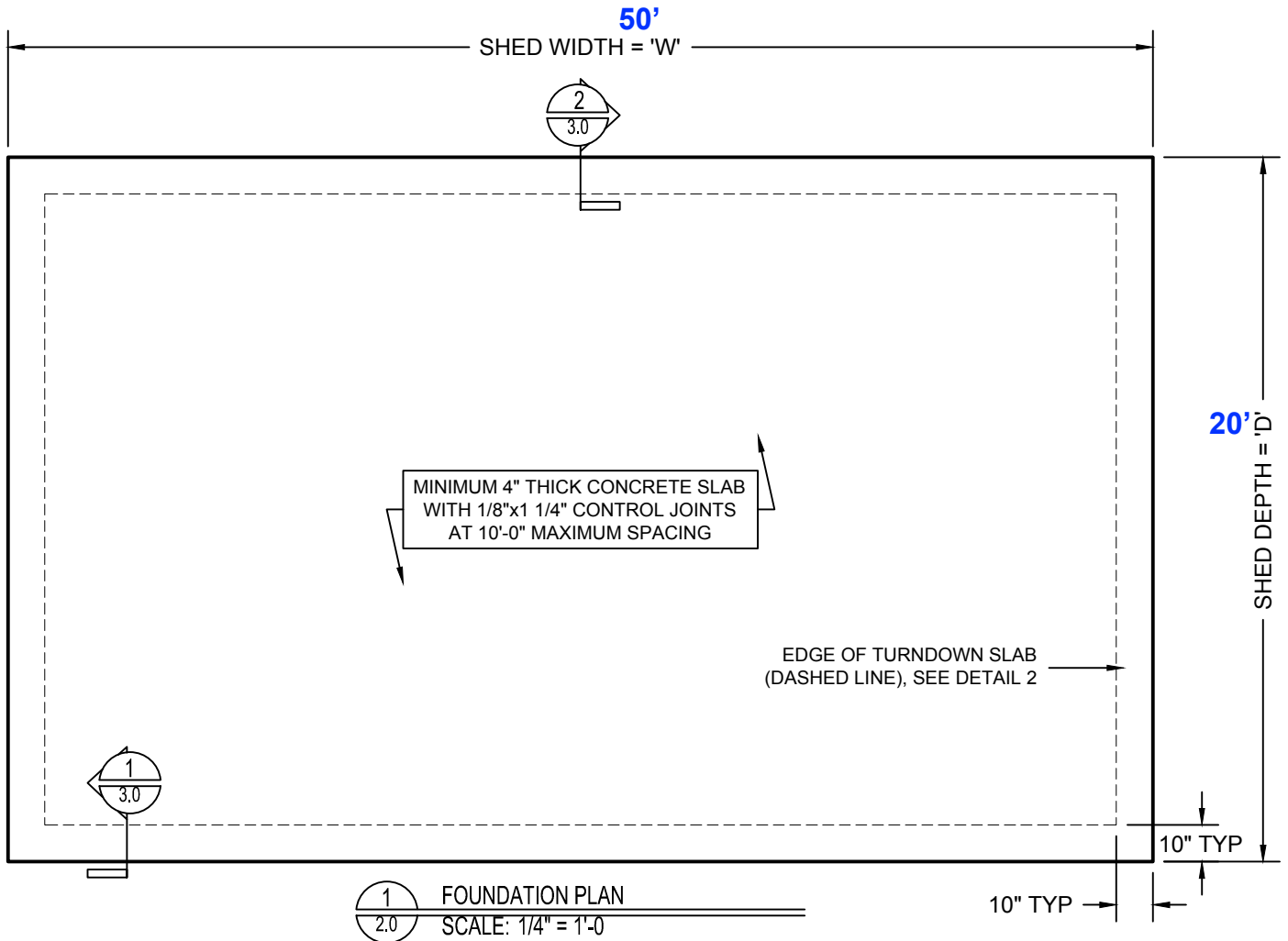

| 14x SHED SLAB SIZE | | |
|--------------------|--------|--------|
| SHED SIZE (DxW) | 'D' | 'W' |
| 14' x 18' | 14'-0" | 18'-0" |
| 14' x 22' | 14'-0" | 22'-0" |
| 14' x 26' | 14'-0" | 26'-0" |
| 14' x 30' | 14'-0" | 30'-0" |
| 14' x 34' | 14'-0" | 34'-0" |

| 16x SHED SLAB SIZE | | |
|--------------------|--------|--------|
| SHED SIZE (DxW) | 'D' | 'W' |
| 16' x 18' | 16'-0" | 18'-0" |
| 16' x 22' | 16'-0" | 22'-0" |
| 16' x 26' | 16'-0" | 26'-0" |
| 16' x 30' | 16'-0" | 30'-0" |
| 16' x 34' | 16'-0" | 34'-0" |
| 16' x 38' | 16'-0" | 38'-0" |

| 18x SHED SLAB SIZE | | |
|--------------------|--------|--------|
| SHED SIZE (DxW) | 'D' | 'W' |
| 18' x 18' | 18'-0" | 18'-0" |
| 18' x 22' | 18'-0" | 22'-0" |
| 18' x 26' | 18'-0" | 26'-0" |
| 18' x 30' | 18'-0" | 30'-0" |
| 18' x 34' | 18'-0" | 34'-0" |
| 18' x 38' | 18'-0" | 38'-0" |
| 18' x 42' | 18'-0" | 42'-0" |
| 18' x 46' | 18'-0" | 46'-0" |

| 20x SHED SLAB SIZE | | |
|--------------------|--------|--------|
| SHED SIZE (DxW) | 'D' | 'W' |
| 20' x 22' | 20'-0" | 22'-0" |
| 20' x 26' | 20'-0" | 26'-0" |
| 20' x 30' | 20'-0" | 30'-0" |
| 20' x 34' | 20'-0" | 34'-0" |
| 20' x 38' | 20'-0" | 38'-0" |
| 20' x 42' | 20'-0" | 42'-0" |
| 20' x 46' | 20'-0" | 46'-0" |
| 20' x 50' | 20'-0" | 50'-0" |

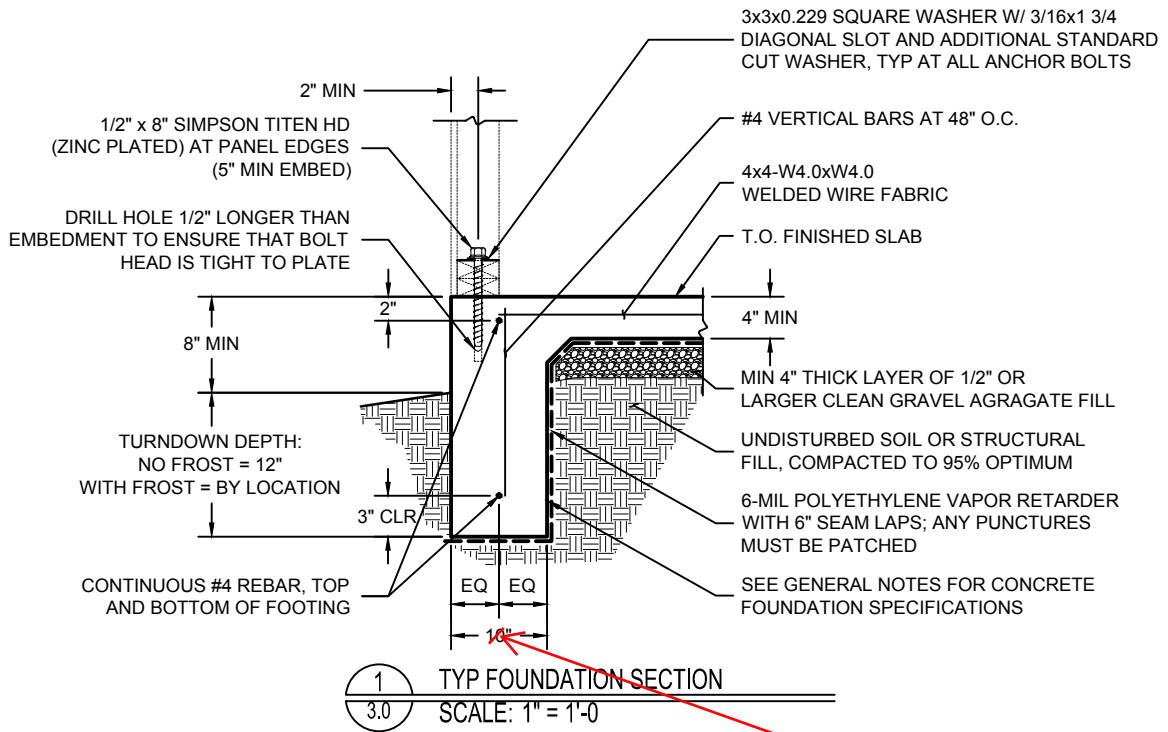

12" minimum

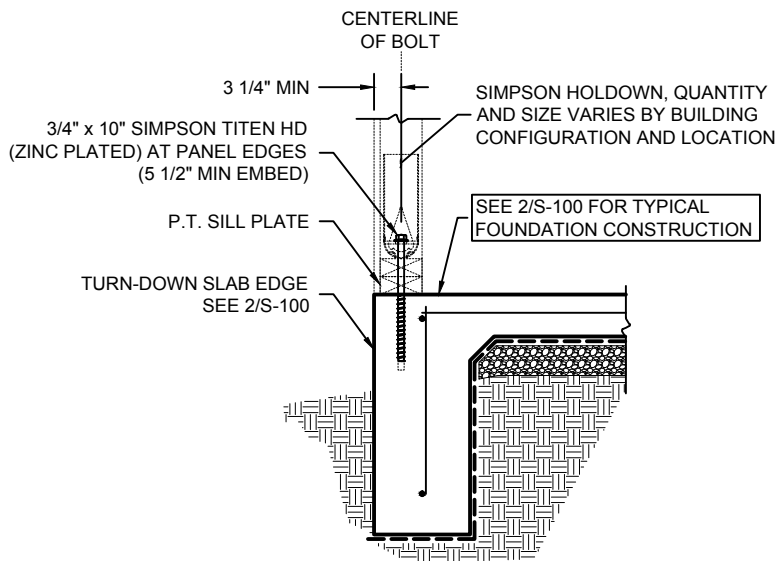

2 SECTION AT HOLDDOWN

3.0 SCALE: 1" = 1'-0"

FOUNDATION NOTES:

1. HOLDOWN CONNECTOR BOLTS INTO WOOD FRAMING REQUIRE APPROVED PLATE WASHERS; AND HOLDDOWNS SHALL BE FINGER TIGHT AND 1/2 WRENCH TURN JUST PRIOR TO COVERING THE WALL FRAMING. CONNECTOR BOLTS INTO WOOD FRAMING REQUIRE STEEL PLATE WASHERS ON THE POST ON THE OPPOSITE SIDE OF THE ANCHORAGE DEVICE. PLATE SIZE SHALL BE A MINIMUM OF 0.299 INCH BY 3 INCHES BY 3 INCHES. (2305.5)

3. ALL BOLT HOLES THROUGH WOOD SHALL BE DRILLED 1/32" TO 1/16" OVERSIZED. (11.1.2.2, 2012 NDS)

TITEN HD® Heavy Duty Screw Anchor for Cracked and Uncracked Concrete: Titen HD® Installation

Holes in metal fixtures to be mounted should match the diameter specified in the table on the [table below](#).

- Drill a hole in the base material using a carbide drill bit the same diameter as the nominal diameter of the anchor to be installed. Drill the hole to the specified embedment depth plus 1/2" minimum to allow the thread tapping dust to settle and blow it clean using compressed air. Overhead installations need not be blown clean. Alternatively, drill the hole deep enough to accommodate embedment depth and dust from drilling and tapping.
- Insert the anchor through the fixture and into the hole.
- Tighten the anchor into the base material until the hex washer head contacts the fixture.
- Do not use impact wrenches to install into hollow CMU.



Caution: Oversized holes in the base material will reduce or eliminate the mechanical interlock of the threads with the base material and will reduce the anchor's load capacity. Use a Titen HD screw anchor one time only. Installing the anchor multiple times may result in excessive thread wear and reduce load capacity.

Installation Sequence

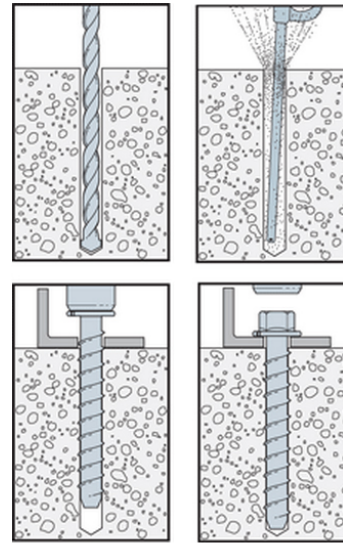

Titen HD® Installation Information and Additional Data^{1,4}

| Characteristic | Symbol | Units | Nominal Anchor Diameter, d_a (in.) | | | | | | | | | |
|--|------------------|-----------------|--------------------------------------|-------|------------------|-------|------------------|-------|------------------|-------|------------------|--------|
| | | | 1/4 | | 3/8 | | 1/2 | | 5/8 | | 3/4 | |
| Installation Information | | | | | | | | | | | | |
| Drill Bit Diameter | d_{bit} | in. | 1/4 | | 3/8 | | 1/2 | | 5/8 | | 3/4 | |
| Baseplate Clearance Hole Diameter | d_c | in. | 3/8 | | 1/2 | | 5/8 | | 3/4 | | 7/8 | |
| Maximum Installation Torque | $T_{inst,max}$ | ft-lb | 24 ² | | 50 ² | | 65 ² | | 100 ² | | 150 ² | |
| Maximum Impact Wrench Torque Rating | $T_{impact,max}$ | ft-lb | 125 ³ | | 150 ³ | | 340 ³ | | 340 ³ | | 385 ³ | |
| Embedment Depth | h_{nom} | in. | 1 5/8 | 2 1/2 | 2 1/2 | 3 1/4 | 3 1/4 | 4 | 4 | 5 1/2 | 5 1/2 | 6 1/4 |
| Critical Edge Distance | C_{ac} | in. | 3 | 6 | 2 11/16 | 3 5/8 | 3 9/16 | 4 1/2 | 4 1/2 | 6 3/8 | 6 3/8 | 7 5/16 |
| Minimum Edge Distance | C_{min} | in. | 1 1/2 | | 1 3/4 | | | | | | | |
| Minimum Spacing | S_{min} | in. | 3 | | | | | | | | | |
| Minimum Concrete Thickness | h_{min} | in. | 3 1/4 | 3 1/2 | 3 3/4 | 5 | 5 | 3 1/4 | 6 | 8 1/2 | 3/4 | 10 |
| Additional Data | | | | | | | | | | | | |
| Anchor Category | category | — | 1 | | | | | | | | | |
| Yield Strength | f_{ya} | psi | 100,000 | | | | 97,000 | | | | | |
| Tensile Strength | f_{uta} | psi | 125,000 | | | | 110,000 | | | | | |
| Minimum Tensile & Shear Stress Area | A_{se} | in ² | 0.0415 | | 0.099 | | 0.183 | | 0.276 | | .0414 | |
| Axial Stiffness in Service Load Range - Uncracked Concrete | β_{unscr} | lb/in. | 202,000 | | | | 715,000 | | | | | |
| Axial Stiffness in Service Load Range - Cracked Concrete | β_{cr} | lb/in. | 173,000 | | | | 345,000 | | | | | |

1. The information presented in this table is to be used in conjunction with the design criteria of ACI 318 Appendix D.
2. $T_{inst,max}$ is the maximum permitted installation torque for the embedment depth range covered by this table for installations using a torque wrench.
3. $T_{impact,max}$ is the maximum permitted torque rating for impact wrenches for the embedment depth range covered by this table.
4. Data for 1/4" anchor is only valid for THDB25 series. Data for the 5/8" anchor is valid only for the THDB62 series.



STUDIO SHED
 1500 CHERRY ST STE S
 LOUISVILLE, CO 80027
 888.900.3933

SUBMITTAL DOCUMENTS

JOB #:
 PROJECT NAME:
 EVANS
 PROJECT LOCATION:
 BROADWAY, NC (CHAPEL HILL)
 SIGNATURE:
 DATE:

20x50 LP

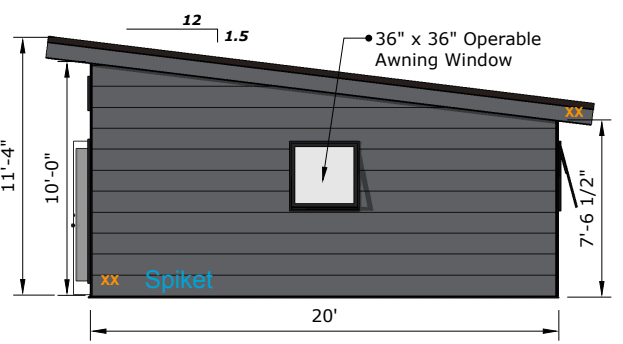

RIGHT ELEVATION 3/16" = 1'-0"

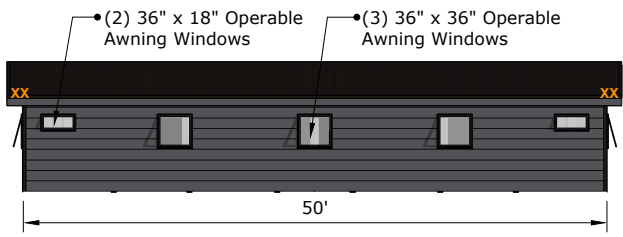

BACK ELEVATION 3/32" = 1'-0"

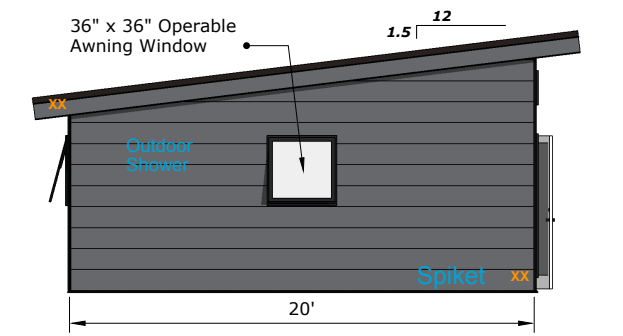

LEFT ELEVATION 3/16" = 1'-0"

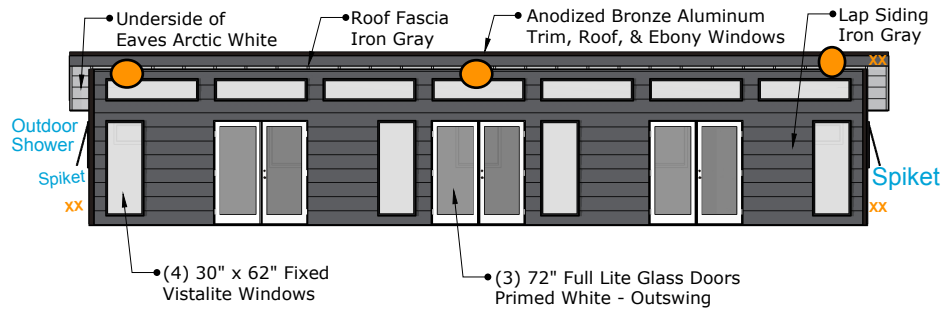

FRONT ELEVATION 1/8" = 1'-0"

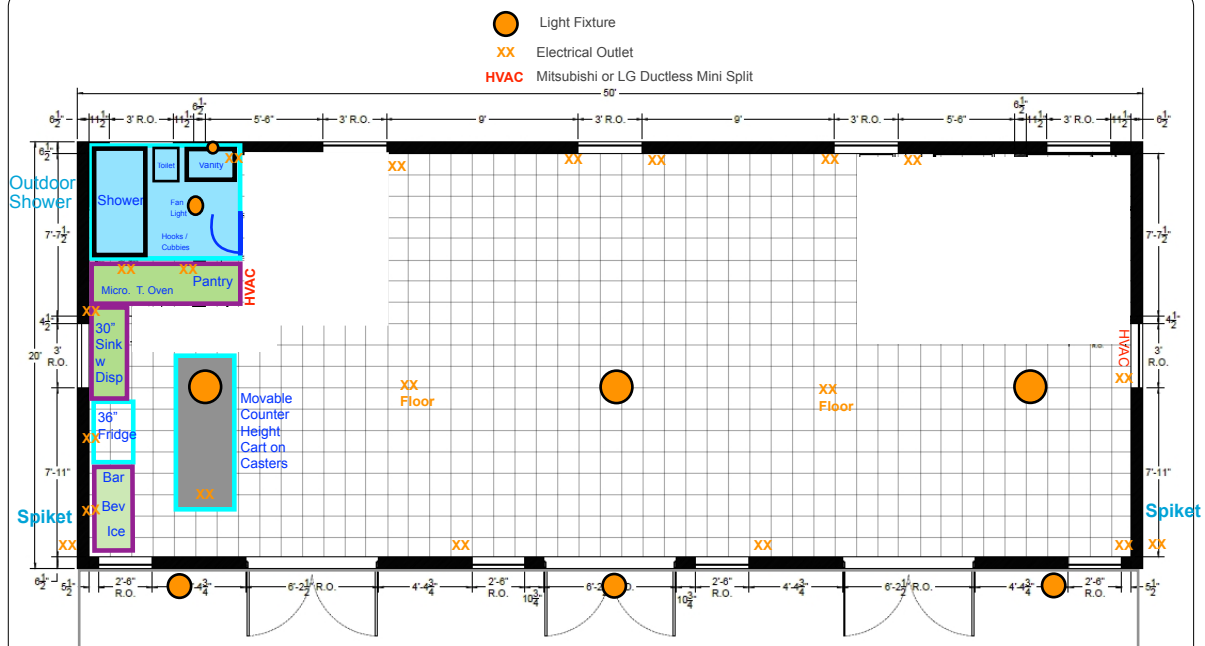

FLOOR PLAN NOTE: INTERIOR DIMENSIONS ASSUME 1/2" DRYWALL ~3/16" = 1'-0"



FLOOR PLAN

NOTE: INTERIOR DIMENSIONS ASSUME 1/2" DRYWALL

~3/16" = 1'-0"