



## STRUCTURAL DESIGN

### ENCLOSED BUILDING

**MAXIMUM 30'- 0" WIDE X 14'- 0" HEIGHT-  
BOX EAVE FRAME AND BOW FRAME**

**5 November 2018**

**Revision 6**

**M&A Project No. 17062S/17174S/17254S/18033S/18113S/18246S**

**Prepared for:**

**Newmart Builders  
1000 Cycle Lane  
South Hill, VA 23970**

**Prepared by:**

**Moore and Associates Engineering and Consulting, Inc.**

**1009 East Avenue  
North Augusta, SC 29841**

**401 S. Main Street, Suite 200  
Mount Airy, NC 27030**



**MOORE AND ASSOCIATES  
ENGINEERING AND CONSULTING**

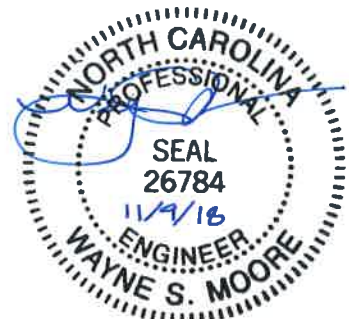



# DRAWING INDEX

SHEET 1	PE SEAL COVER SHEET
SHEET 2	DRAWING INDEX
SHEET 3A	INSTALLATION NOTES AND SPECIFICATIONS
SHEET 3B	TYPICAL SIDE AND END ELEVATIONS
SHEET 4	TYPICAL RAFTER/COLUMN END AND SIDE FRAMING SECTIONS (BOX EAVE RAFTER)
SHEET 5A	24'-0" < W < 30'-0" MAXIMUM RAFTER SPAN CONNECTION DETAILS (BOX EAVE RAFTER)
SHEET 5B	W < 24'-0" MAXIMUM RAFTER SPAN CONNECTION DETAILS (BOX EAVE RAFTER)
SHEET 6	TYPICAL RAFTER/COLUMN END AND SIDE FRAMING SECTIONS (BOW RAFTER)
SHEET 7A	24'-0" < W < 30'-0" MAXIMUM RAFTER SPAN CONNECTION DETAILS (BOW RAFTER)
SHEET 7B	W < 24'-0" MAXIMUM RAFTER SPAN CONNECTION DETAILS (BOW RAFTER)
SHEET 8	BASE RAIL ANCHORAGE OPTIONS
SHEET 9	BOX EAVE RAFTER END WALL AND SIDE WALL OPENINGS
SHEET 10	BOW EAVE RAFTER END WALL AND SIDE WALL OPENINGS
SHEET 11	BOX AND BOW EAVE RAFTER WALL OPENING DETAILS
SHEET 12	BOX AND BOW EAVE RAFTER WALL OPENING DETAILS
SHEET 13	BOX EAVE RAFTER LEAN-TO OPTION
SHEET 14	BOW RAFTER LEAN-TO OPTION
SHEET 15	BOX EAVE RAFTER VERTICAL ROOF/SIDING OPTION
SHEET 16	ADDITIONAL BASE RAIL ANCHORAGE OPTION



<b>MOORE AND ASSOCIATES ENGINEERING AND CONSULTING, INC.</b>	DRAWN BY: LT	NEWMART BUILDERS, INC. 1000 CYCLE LANE SOUTH HILL, VA 23970 30'-0"x14'-0" ENCLOSED STRUCTURE		
	CHECKED BY: PDH			
THIS DOCUMENT IS THE PROPERTY OF MOORE AND ASSOCIATES ENGINEERING AND CONSULTING. THE UNAUTHORIZED REPRODUCTION, COPYING, OR OTHERWISE USE OF THIS DOCUMENT IS STRICTLY PROHIBITED AND ANY INFRINGEMENT THEREUPON MAY BE SUBJECT TO LEGAL ACTION.	PROJECT MGR: WSM	DATE: 11-5-18	SCALE: NTS	JOB NO: 18033S/18113S/18246S
	CLIENT: NEWMART BUILDERS	SHT. 2	DWG. NO: SK-3	REV: 6

## INSTALLATION NOTES AND SPECIFICATIONS

1. DESIGN IS FOR MAXIMUM 30'-0" WIDE x 14'-0" EAVE HEIGHT ENCLOSED STRUCTURES.
2. DESIGN WAS DONE IN ACCORDANCE WITH THE 2018 NORTH CAROLINA BUILDING CODE, 2006 INTERNATIONAL BUILDING CODE (IBC), 2009 IBC, 2012 IBC AND 2015 IBC.
3. DESIGN LOADS ARE AS FOLLOWS:
  - A) DEAD LOAD = 15 PSF
  - B) LIVE LOAD = 12 PSF
  - C) GROUND SNOW LOAD = 30 PSF ( $W \leq 24'-0"$ )  
 = 35 PSF ( $18'-0" < W \leq 30'-0"$ )  
 = 45 PSF @ 4'-0" O.C. MAX. RAFTER/COLUMN AND END COLUMN SPACING ( $24'-0" < W \leq 30'-0"$ )  
 @ 5'-0" O.C. MAX. RAFTER/COLUMN AND END COLUMN SPACING ( $W \leq 24'-0"$ )
4. LOW ULTIMATE WIND SPEED (LW) 105 TO 130 MPH (NOMINAL WIND SPEED 81 TO 101 MPH); MAXIMUM RAFTER/POST AND END COLUMN SPACING = 50 FEET (UNLESS NOTED OTHERWISE).
5. END WALL COLUMNS (POST) ARE SIMILAR TO SIDE WALL POSTS UNLESS NOTED OTHERWISE.
6. RISK CATEGORY I.
7. WIND EXPOSURE CATEGORY B.
8. SPECIFICATIONS APPLICABLE TO 29 GAUGE METAL PANELS FASTENED DIRECTLY TO 2"x3"-14 GAUGE TUBE STEEL (TS) FRAMING MEMBERS FOR ( $24'-0" < W \leq 30'-0"$  AND  $W \leq 24'-0"$  WITH EAVE HEIGHT  $12'-0" < TO \leq 14'-0"$ ) & 1/4"x2 1/4"-14 GAUGE TUBE STEEL (TS) FOR ( $W \leq 24'-0"$ ) (UNLESS NOTED OTHERWISE).
9. AVERAGE FASTENER SPACING ON-CENTERS ALONG RAFTERS OR HAT CHANNELS AND COLUMNS (INTERIOR OR END) = 10" O.C. (MAX.)
10. FASTENERS CONSIST OF 1/4"x3/4" SELF-DRILLING FASTENER (SDF), USE CONTROL SEAL WASHER WITH EXTERIOR FASTENERS SPECIFICATIONS APPLICABLE ONLY FOR MEAN ROOF HEIGHT OF 20 FEET OR LESS, AND ROOF SLOPES OF 14° (3:12 PITCH) OR LESS SPACING REQUIREMENTS FOR OTHER ROOF HEIGHTS AND/OR SLOPES MAY VARY.
11. GROUND ANCHORS SHALL BE INSTALLED THROUGH BASE RAIL WITHIN 6" OF EACH RAFTER COLUMN ALONG SIDES.
12. GROUND ANCHORS CONSIST OF #4 REBAR W/ WELDED NUT/FORMED HEAD x 30" LONG IN SUITABLE SOIL CONDITIONS OPTIGNAL ANCHORAGE MAY BE USED IN SUITABLE SOILS AND MUST BE USED IN UNSUITABLE SOILS AS NOTED.
13. WIND FORCES GOVERN OVER SEISMIC FORCES SEISMIC PARAMETERS ANALYZED ARE:  
 SOIL SITE CLASS = D  
 RISK CATEGORY I/II/III  
 R = 3.25                       $I_e = 1.0$   
 $S_{DS} = 2.039$                   V =  $C_s W$   
 $S_{DI} = 1.258$



**MOORE AND ASSOCIATES  
ENGINEERING AND CONSULTING, INC.**

**DRAWN BY:** LT

**CHECKED BY:** PDH

**PROJECT MGR:** WSM

**CLIENT:** NEWMART BUILDERS

NEWMART BUILDERS, INC.

1000 CYCLE LANE

SOUTH HILL, VA 23970

30'-0"x14'-0" ENCLOSED STRUCTURE

**DATE:** 11-5-18

**SHT:** 3A

**SCALE:** NTS

**DWG. NO:** SK-3

**JOB NO:**

18033S/18113S/19246S

**REV:** 6

THIS DOCUMENT IS THE PROPERTY OF MOORE AND ASSOCIATES ENGINEERING AND CONSULTING. THE UNAUTHORIZED REPRODUCTION, COPYING, OR OTHERWISE USE OF THIS DOCUMENT IS STRICTLY PROHIBITED AND ANY INFRINGEMENT THEREUPON MAY BE SUBJECT TO LEGAL ACTION.

**BOX EAVE FRAME RAFTER STRUCTURE (Sheets 4, 5A, 5B, 8, 9, 11, 12, 13, 15 AND 16)**

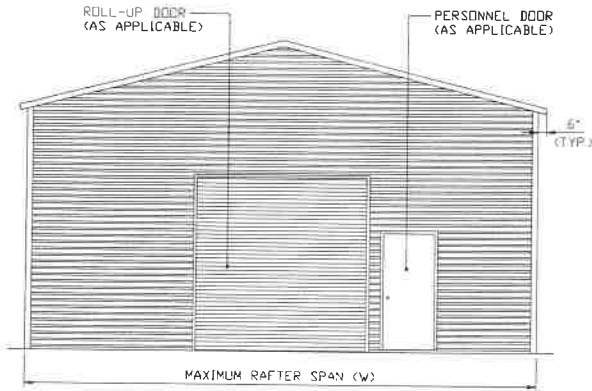

**TYPICAL END ELEVATION**

SCALE: NTS

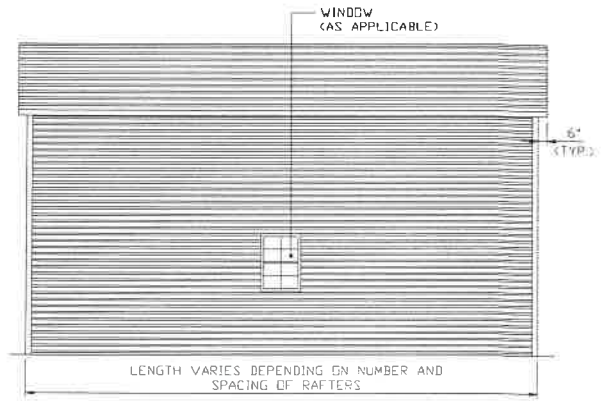

**TYPICAL SIDE ELEVATION**

SCALE: NTS

**BOW FRAME RAFTER STRUCTURE (Sheets 6, 7A, 7B, 8, 10, 11, 12, 14 AND 16)**

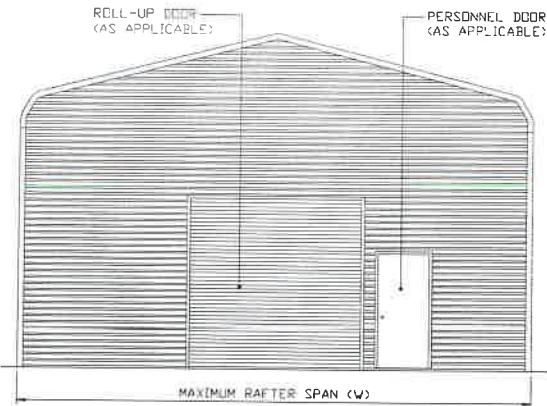

**TYPICAL END ELEVATION**

SCALE: NTS

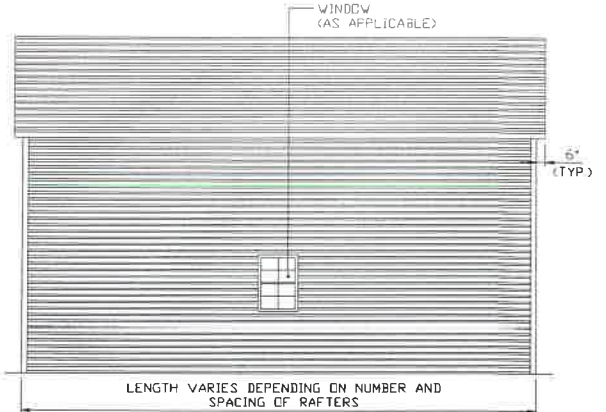

**TYPICAL SIDE ELEVATION**

SCALE: NTS



**MOORE AND ASSOCIATES  
ENGINEERING AND CONSULTING, INC.**

DRAWN BY: LT

CHECKED BY: PDH

PROJECT MGR: WSM

CLIENT: NEWMART BUILDERS

NEWMART BUILDERS, INC.

1000 CYCLE LANE

SOUTH HILL, VA 23970

30'-0"x14'-0" ENCLOSED STRUCTURE

DATE: 11-5-18

SHT. 3B

SCALE: NTS

DWG. NO: SK-3

JOB NO:  
18033S/18113S/18246S

REV. 6

THIS DOCUMENT IS THE PROPERTY OF MOORE AND ASSOCIATES ENGINEERING AND CONSULTING. THE UNAUTHORIZED REPRODUCTION, COPYING, OR OTHERWISE USE OF THIS DOCUMENT IS STRICTLY PROHIBITED AND ANY INFRINGEMENT THEREUPON MAY BE SUBJECT TO LEGAL ACTION.



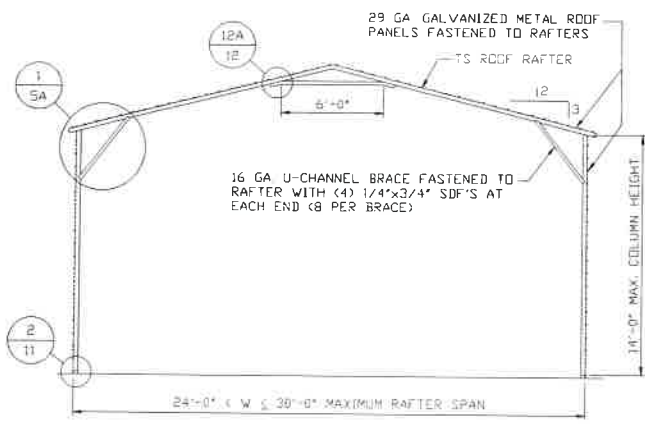

**TYPICAL RAFTER/COLUMN END FRAME SECTION**  
SCALE: NTS

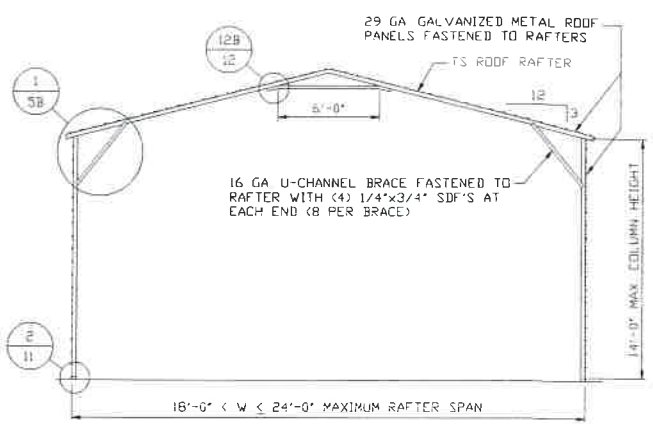

**TYPICAL RAFTER/COLUMN END FRAME SECTION**  
SCALE: NTS

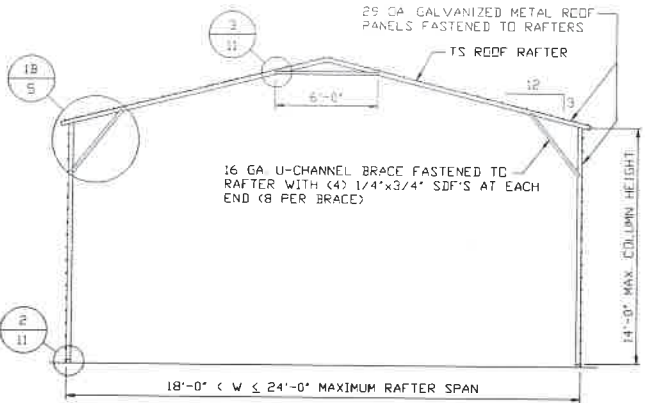

**TYPICAL RAFTER/COLUMN END FRAME SECTION**  
SCALE: NTS

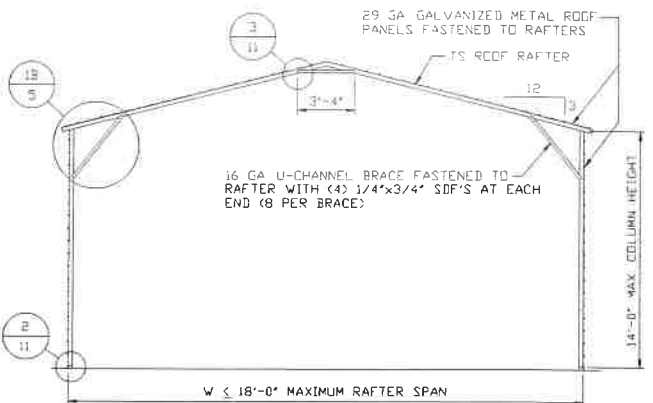

**TYPICAL RAFTER/COLUMN END FRAME SECTION**  
SCALE: NTS

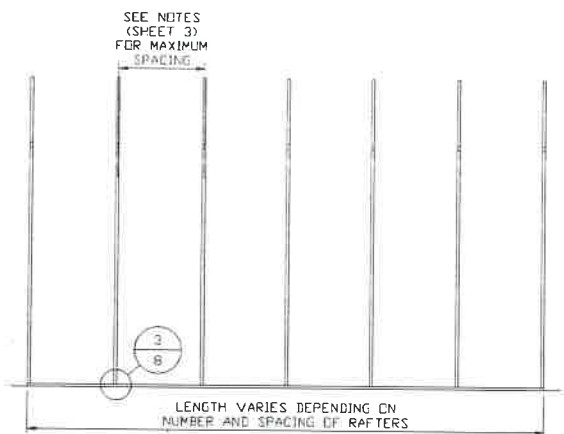

**TYPICAL RAFTER/COLUMN SIDE FRAMING SECTION**  
SCALE: NTS



<b>MOORE AND ASSOCIATES ENGINEERING AND CONSULTING, INC.</b>	DRAWN BY: LT	NEWMART BUILDERS, INC. 1000 CYCLE LANE SOUTH HILL, VA 23970 30'-0" x 14'-0" ENCLOSED STRUCTURE		
	CHECKED BY: PDH			
THIS DOCUMENT IS THE PROPERTY OF MOORE AND ASSOCIATES ENGINEERING AND CONSULTING. THE UNAUTHORIZED REPRODUCTION, COPYING, OR OTHERWISE USE OF THIS DOCUMENT IS STRICTLY PROHIBITED AND ANY INFRINGEMENT THEREUPON MAY BE SUBJECT TO LEGAL ACTION.	PROJECT MGR: WSM	DATE: 11-5-18	SCALE: NTS	JOB NO: 18033S/18113S/18246S
	CLIENT: NEWMART BUILDERS	SHT. 4	DWG. NO: SK-3	REV: 6

**24'-0" < W ≤ 30'-0" MAXIMUM RAFTER SPAN**

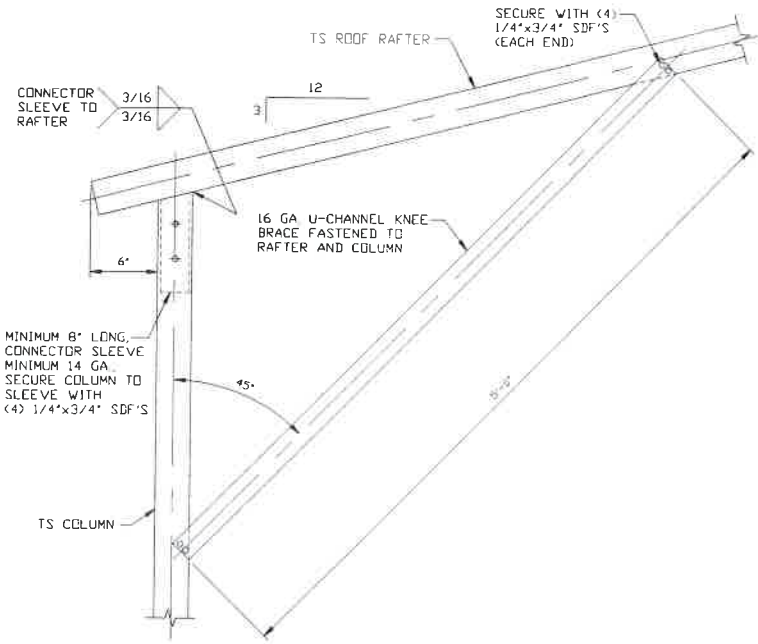

**1A** BOX EAVE RAFTER COLUMN CONNECTION DETAIL  
HEIGHTS 12'-0" < TO ≤ 14'-0" @ 3'-6" O.C.  
SCALE: NTS

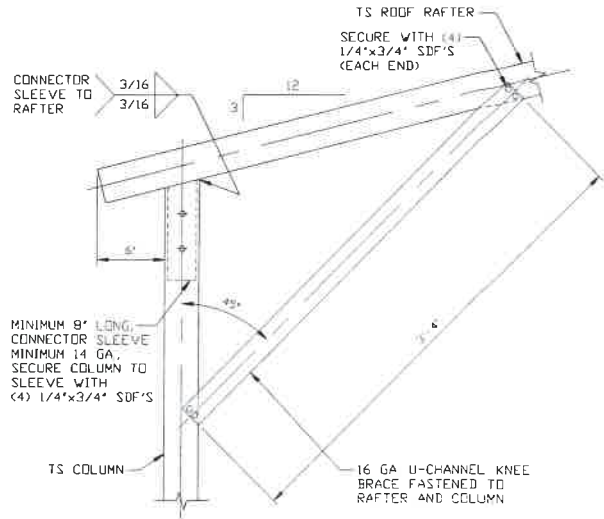

**1C** BOX EAVE RAFTER COLUMN CONNECTION DETAIL  
HEIGHTS ≤ 10'-0"  
SCALE: NTS

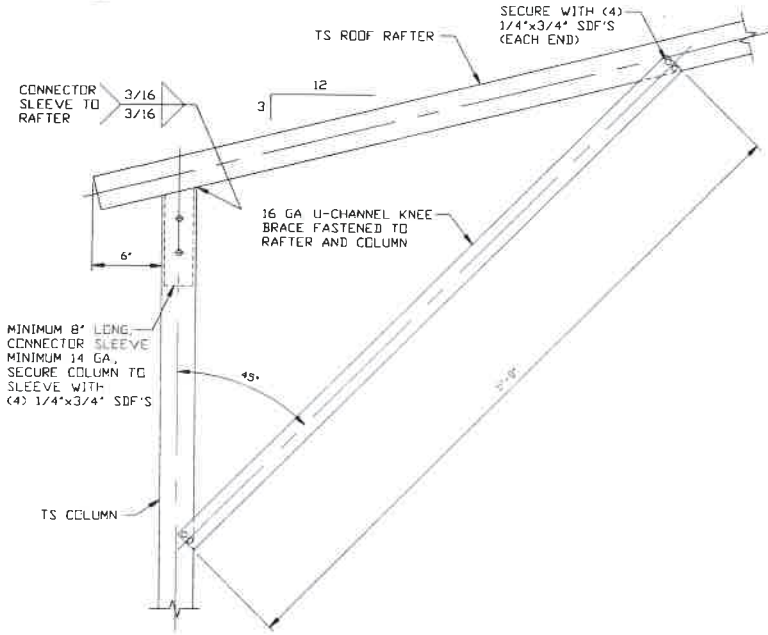

**1B** BOX EAVE RAFTER COLUMN CONNECTION DETAIL  
HEIGHTS 10'-0" < TO ≤ 12'-0"  
SCALE: NTS

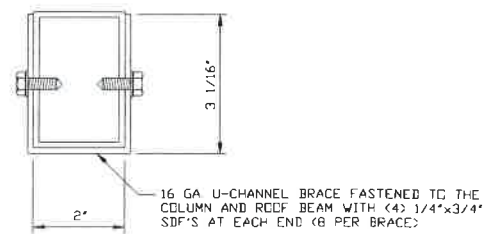

**BRACE SECTION**  
SCALE: NTS



**MOORE AND ASSOCIATES ENGINEERING AND CONSULTING, INC.**

**DRAWN BY: LT**  
**CHECKED BY: PDH**

**NEWMART BUILDERS, INC.**  
1000 CYCLE LANE  
SOUTH HILL, VA 23970  
30'-0" x 14'-0" ENCLOSED STRUCTURE

THIS DOCUMENT IS THE PROPERTY OF MOORE AND ASSOCIATES ENGINEERING AND CONSULTING. THE UNAUTHORIZED REPRODUCTION, COPYING, OR OTHERWISE USE OF THIS DOCUMENT IS STRICTLY PROHIBITED AND ANY INFRINGEMENT THEREUPON MAY BE SUBJECT TO LEGAL ACTION.

**PROJECT MGR: WSM**  
**CLIENT: NEWMART BUILDERS**

**DATE: 11-5-18**  
**SHT. 5A**  
**SCALE: NTS**  
**DWG. NO: SK-3**  
**JOB NO: 18033S/18113S/18246S**  
**REV: 6**

**W ≤ 24'-0" MAXIMUM RAFTER SPAN**

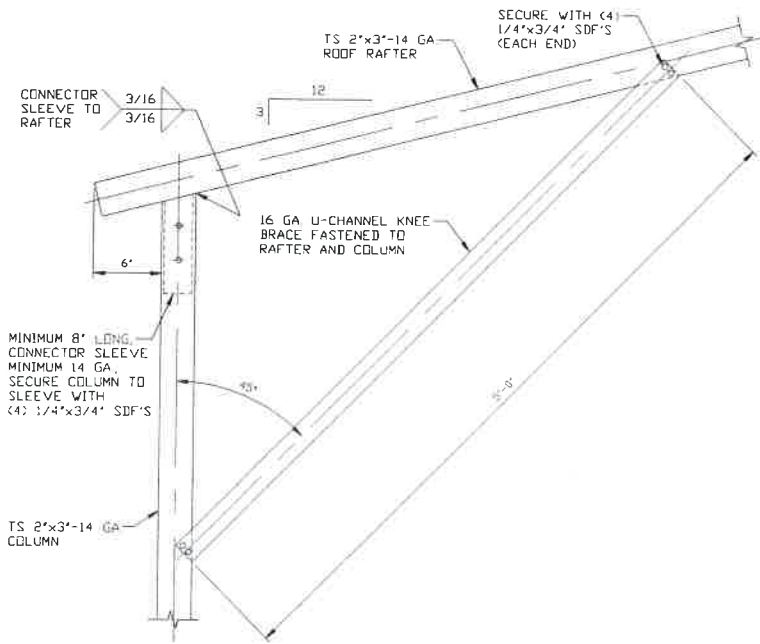

**1A** BOX EAVE RAFTER COLUMN CONNECTION DETAIL  
HEIGHTS 12'-0" < TO ≤ 14'-0" @ 4'-0" O.C.  
SCALE: NTS

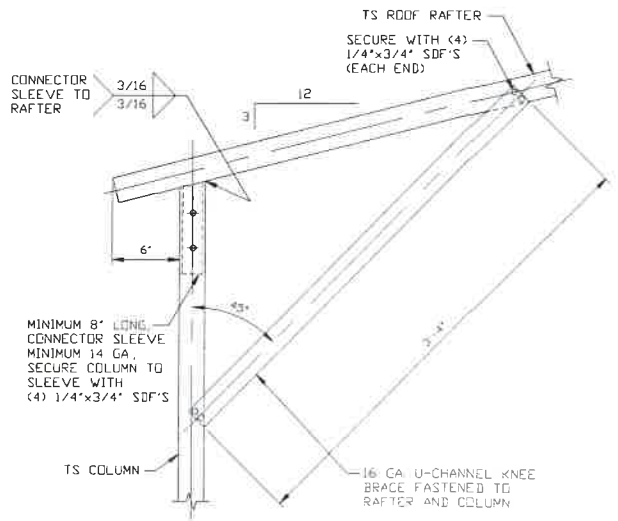

**1C** BOX EAVE RAFTER COLUMN CONNECTION DETAIL  
HEIGHTS ≤ 10'-0"  
SCALE: NTS

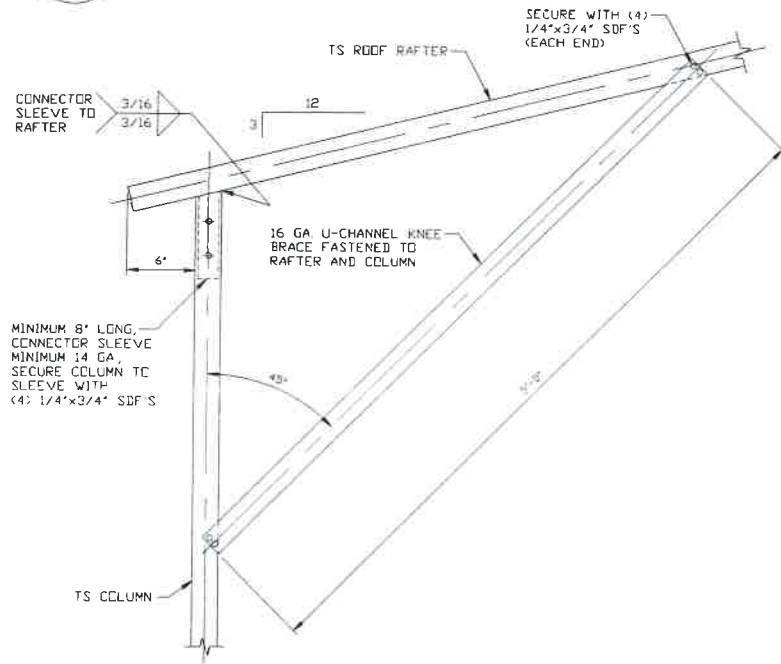

**1B** BOX EAVE RAFTER COLUMN CONNECTION DETAIL  
HEIGHTS 10'-0" < TO ≤ 12'-0" @ 4'-0" O.C.  
SCALE: NTS

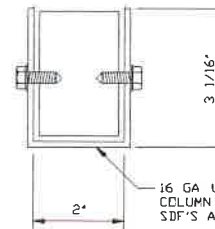

**BRACE SECTION**  
SCALE: NTS

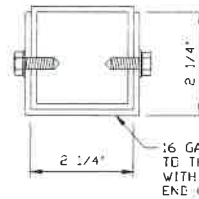

**BRACE SECTION**  
SCALE: NTS



<b>MOORE AND ASSOCIATES ENGINEERING AND CONSULTING, INC.</b>	DRAWN BY: LT	NEWMART BUILDERS, INC. 1000 CYCLE LANE SOUTH HILL, VA 23970 30'-0"x14'-0" ENCLOSED STRUCTURE		
	CHECKED BY: PDH			
THIS DOCUMENT IS THE PROPERTY OF MOORE AND ASSOCIATES ENGINEERING AND CONSULTING. THE UNAUTHORIZED REPRODUCTION, COPYING, OR OTHERWISE USE OF THIS DOCUMENT IS STRICTLY PROHIBITED AND ANY INFRINGEMENT THEREUPON MAY BE SUBJECT TO LEGAL ACTION.	PROJECT MGR: VSM	DATE: 11-5-18	SCALE: NTS	JOB NO: 18033S/18113S/18246S
	CLIENT: NEWMART BUILDERS	SHT. 5B	DWG. NO: SK-3	REV: 6



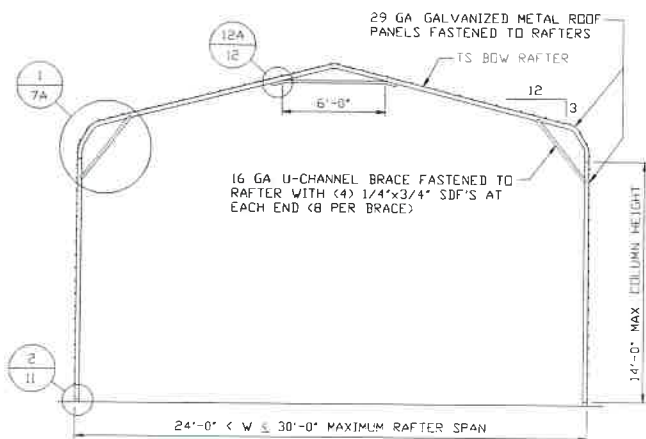

**TYPICAL RAFTER/COLUMN END FRAME SECTION**  
SCALE: NTS

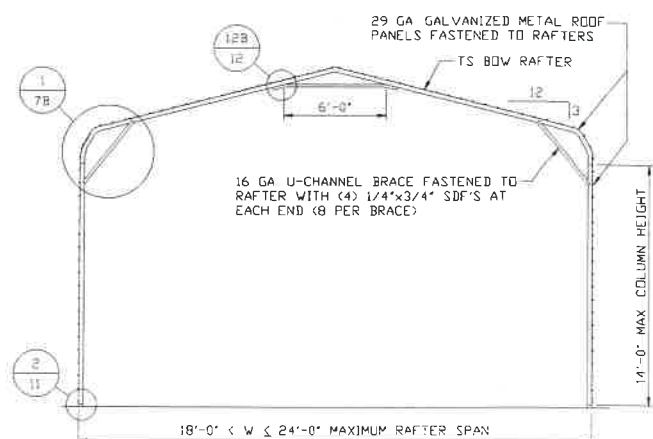

**TYPICAL RAFTER/COLUMN END FRAME SECTION**  
SCALE: NTS

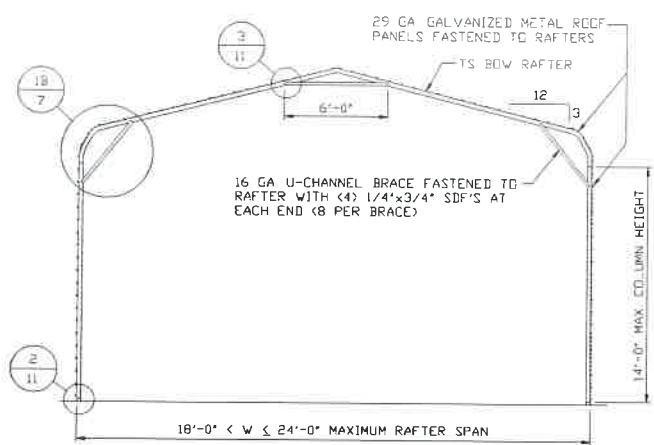

**TYPICAL RAFTER/COLUMN END FRAME SECTION**  
SCALE: NTS

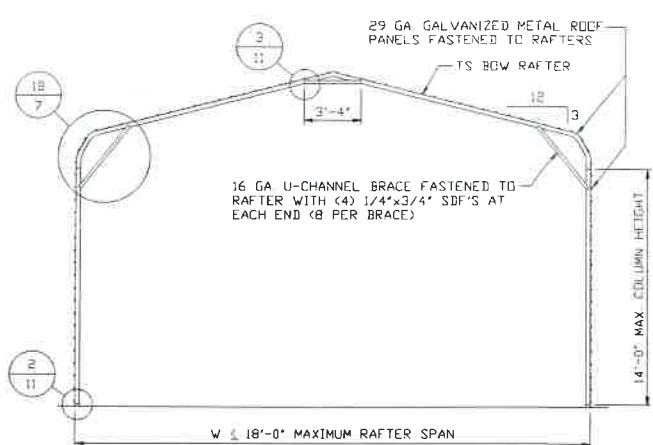

**TYPICAL RAFTER/COLUMN END FRAME SECTION**  
SCALE: NTS

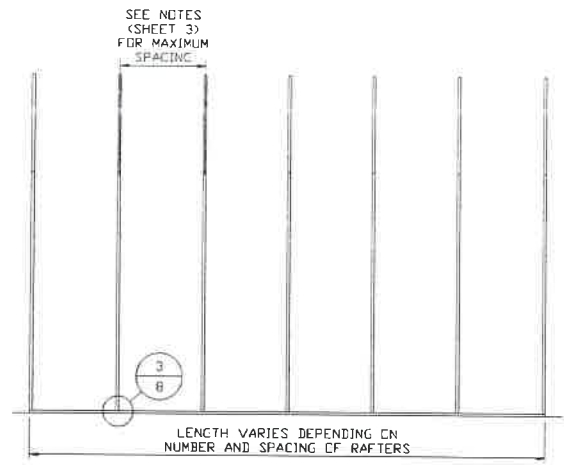

**TYPICAL RAFTER/COLUMN SIDE FRAMING SECTION**  
SCALE: NTS



<b>MOORE AND ASSOCIATES ENGINEERING AND CONSULTING, INC.</b>	DRAWN BY: LT	NEWMART BUILDERS, INC. 1000 CYCLE LANE SOUTH HILL, VA 23970 30'-0"x14'-0" ENCLOSED STRUCTURE		
	CHECKED BY: PDH			
THIS DOCUMENT IS THE PROPERTY OF MOORE AND ASSOCIATES ENGINEERING AND CONSULTING. THE UNAUTHORIZED REPRODUCTION, COPYING, OR OTHERWISE USE OF THIS DOCUMENT IS STRICTLY PROHIBITED AND ANY INFRINGEMENT THEREUPON MAY BE SUBJECT TO LEGAL ACTION.	PROJECT MGR: WSM	DATE: 11-5-18	SCALE: NTS	JOB NO: 18033S/18113S/18246S
	CLIENT: NEWMART BUILDERS	SHT. 6	DWG. NO: SK-3	REV.: 6

**24'-0" < W ≤ 30'-0" MAXIMUM RAFTER SPAN**

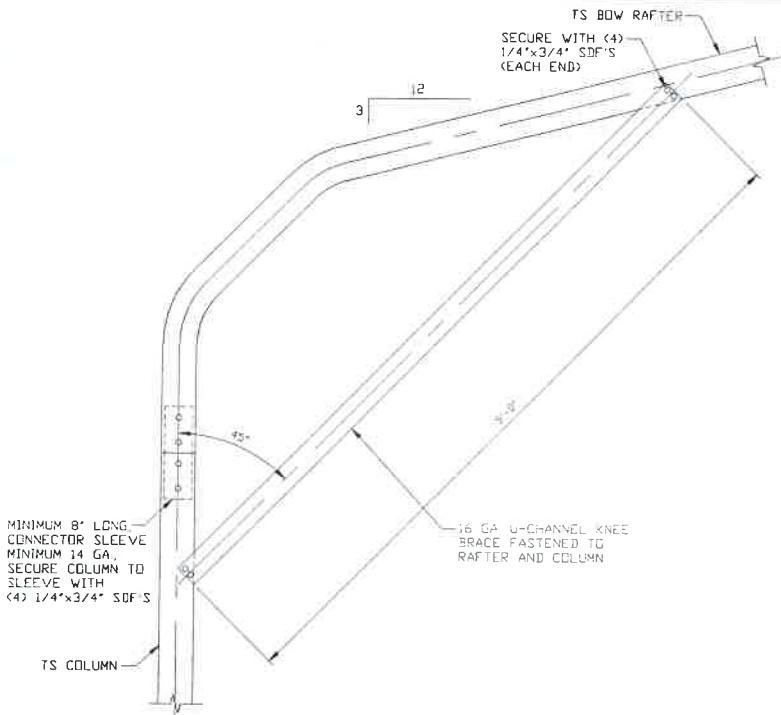

**1A**  
**BOW RAFTER COLUMN CONNECTION DETAIL**  
 HEIGHTS 12'-0" < TO ≤ 14'-0" @ 3'-6" O.C.  
 SCALE: NTS

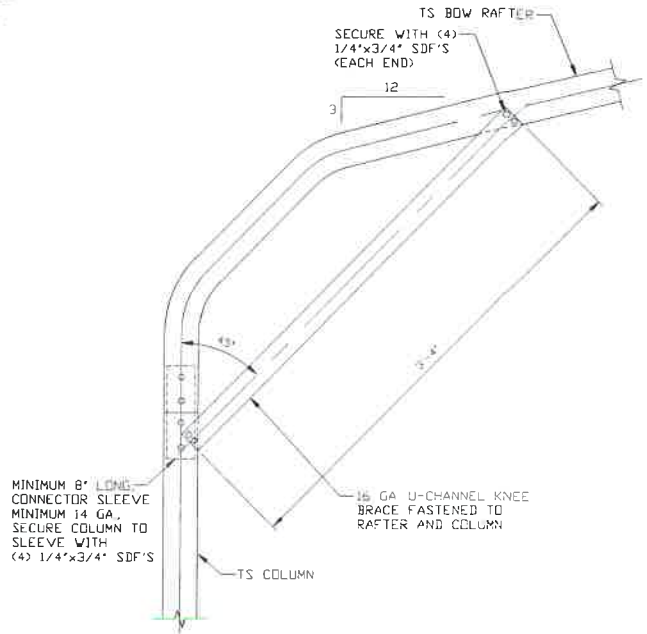

**1C**  
**BOW RAFTER COLUMN CONNECTION DETAIL**  
 HEIGHTS ≤ 10'-0"  
 SCALE: NTS

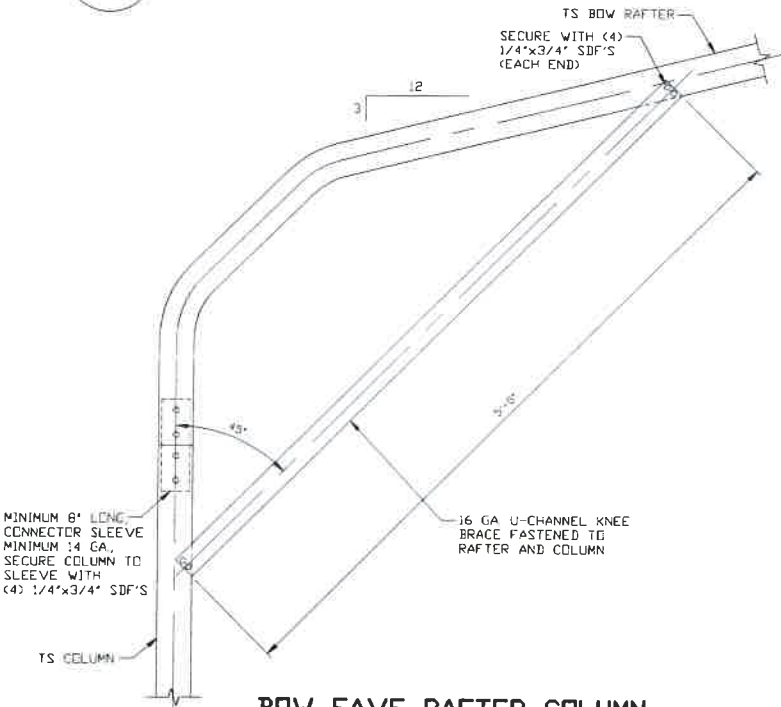

**1B**  
**BOW EAVE RAFTER COLUMN CONNECTION DETAIL**  
 HEIGHTS 10'-0" < TO ≤ 12'-0"  
 SCALE: NTS

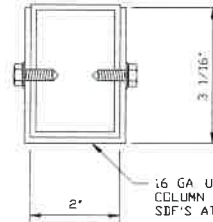

**BRACE SECTION**  
 SCALE: NTS



**MOORE AND ASSOCIATES ENGINEERING AND CONSULTING, INC.**

DRAWN BY: LT

CHECKED BY: PDH

PROJECT MGR: WSM

CLIENT: NEWMART BUILDERS

NEWMART BUILDERS, INC.  
 1000 CYCLE LANE  
 SOUTH HILL, VA 23970  
 30'-0" x 14'-0" ENCLOSED STRUCTURE

DATE: 11-5-18

SHT. 7A

SCALE: NTS

DWG. NO: SK-3

JOB NO: 18033S/18113S/18246S

REV: 6

THIS DOCUMENT IS THE PROPERTY OF MOORE AND ASSOCIATES ENGINEERING AND CONSULTING. THE UNAUTHORIZED REPRODUCTION, COPYING, OR OTHERWISE USE OF THIS DOCUMENT IS STRICTLY PROHIBITED AND ANY INFRINGEMENT THEREUPON MAY BE SUBJECT TO LEGAL ACTION.

**$W \leq 24'-0''$  MAXIMUM RAFTER SPAN**

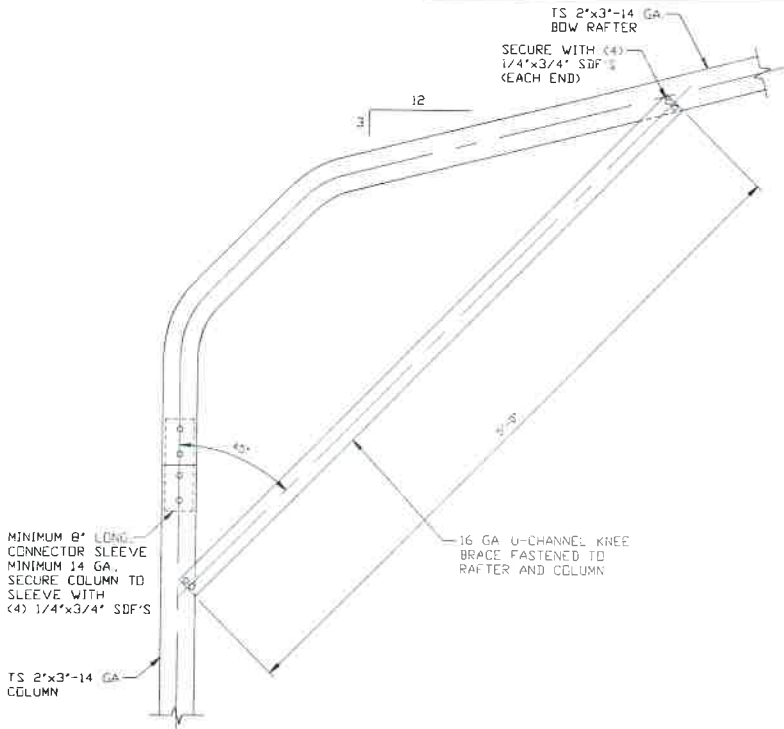

1A

**BOW RAFTER COLUMN CONNECTION DETAIL**  
 HEIGHTS  $12'-0'' < TO \leq 14'-0''$  @  $4'-0''$  O.C.  
 SCALE: NTS

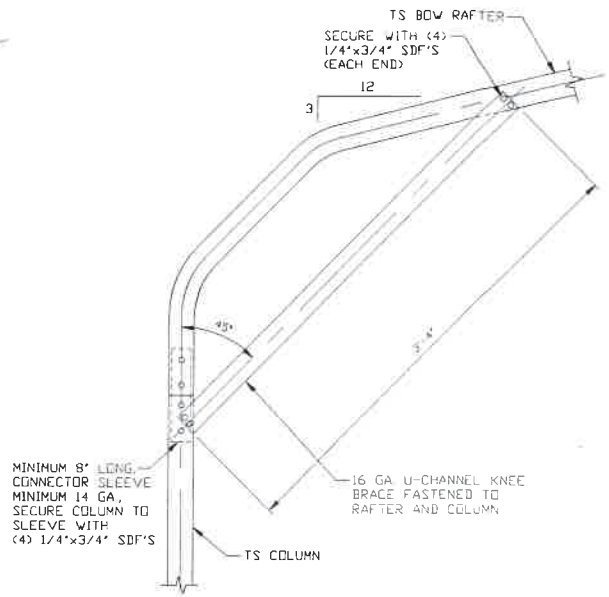

1C

**BOW RAFTER COLUMN CONNECTION DETAIL**  
 HEIGHTS  $\leq 10'-0''$   
 SCALE: NTS

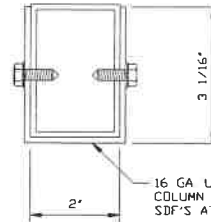

**BRACE SECTION**  
 SCALE: NTS

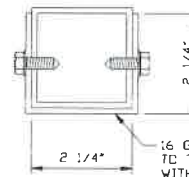

**BRACE SECTION**  
 SCALE: NTS

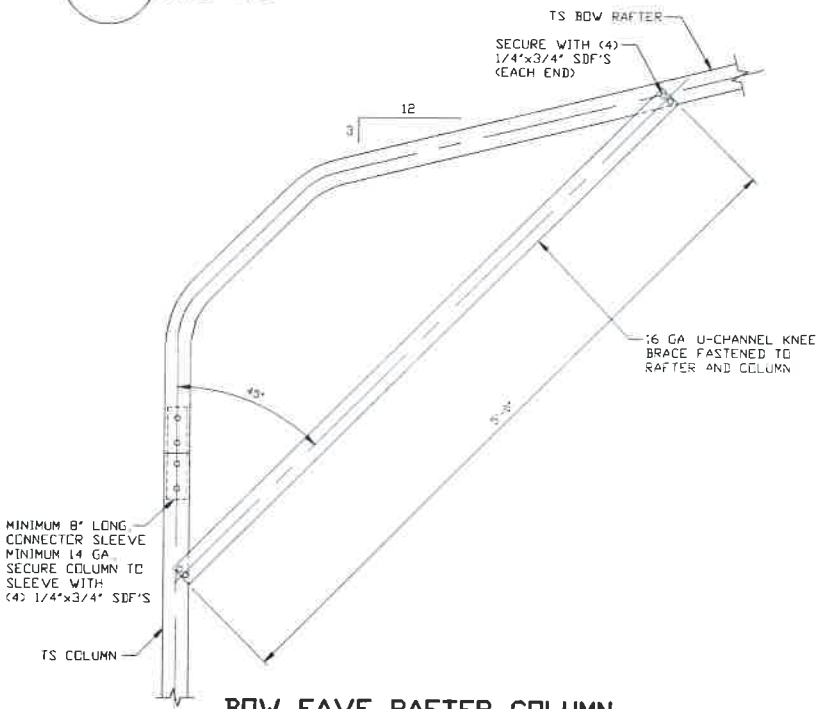

1B

**BOW EAVE RAFTER COLUMN CONNECTION DETAIL**  
 HEIGHTS  $10'-0'' < TO \leq 12'-0''$  @  $4'-0''$  O.C.  
 SCALE: NTS

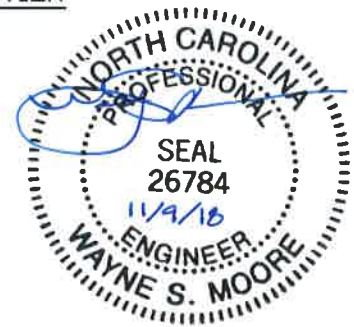

**MOORE AND ASSOCIATES ENGINEERING AND CONSULTING, INC.**

DRAWN BY: LT

CHECKED BY: PDH

PROJECT MGR: WSM

CLIENT: NEWMART BUILDERS

NEWMART BUILDERS, INC.  
 1000 CYCLE LANE  
 SOUTH HILL, VA 23970  
 30'-0"x14'-0" ENCLOSED STRUCTURE

DATE: 11-5-18

SHT. 7B

SCALE: NTS

DWG. NO SK-3

JOB NO: 18033S/18113S/18246S

REV: 6

THIS DOCUMENT IS THE PROPERTY OF MOORE AND ASSOCIATES ENGINEERING AND CONSULTING. THE UNAUTHORIZED REPRODUCTION, COPYING, OR OTHERWISE USE OF THIS DOCUMENT IS STRICTLY PROHIBITED AND ANY INFRINGEMENT THEREUPON MAY BE SUBJECT TO LEGAL ACTION.



## BASE RAIL ANCHORAGE OPTIONS FOR LOW WIND SPEEDS

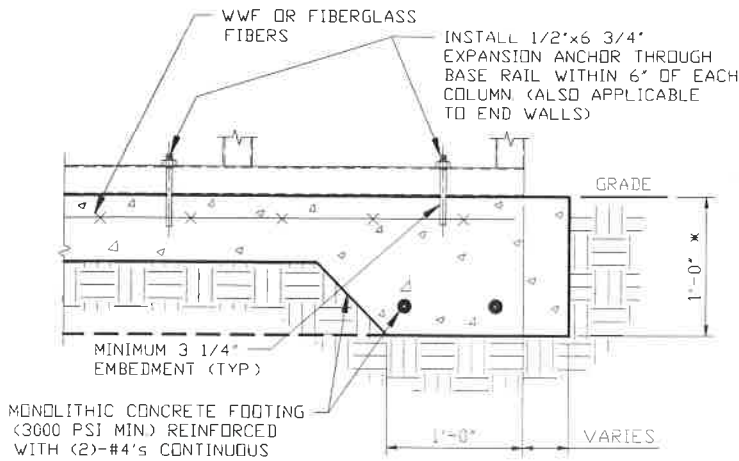

### 3A CONCRETE MONOLITHIC SLAB BASE RAIL ANCHORAGE

SCALE: NTS  
NOTE: MIN ANCHOR EDGE DISTANCE IS 4"  
\* COORDINATE WITH LOCAL CODES/ORD.

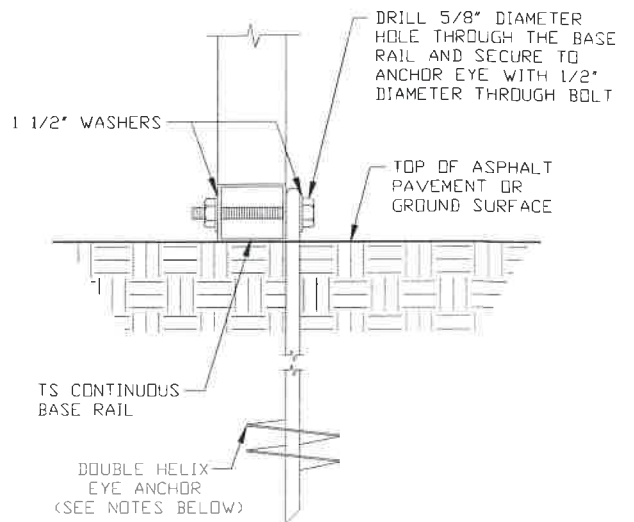

### 3B GROUND BASE HELIX ANCHORAGE

SCALE: NTS (CAN BE USED FOR ASPHALT)

### GENERAL NOTES

NOTE: CONCRETE MONOLITHIC SLAB DESIGN BASED ON MINIMUM SDIL BEARING CAPACITY OF 1,500 PSF

#### CONCRETE:

CONCRETE SHALL HAVE A MINIMUM SPECIFIED COMPRESSIVE STRENGTH OF 3,000 PSI AT 28 DAYS.

#### COVER OVER REINFORCING STEEL:

FOR FOUNDATIONS, MINIMUM CONCRETE COVER OVER REINFORCING BARS SHALL BE PER ACI-318:  
3" IN FOUNDATIONS WHERE THE CONCRETE IS CAST AGAINST AND PERMANENTLY IN CONTACT WITH THE EARTH OR EXPOSED TO THE EARTH OR WEATHER, AND 1 1/2" ELSEWHERE.

#### REINFORCING STEEL:

THE TURNDOWN REINFORCING STEEL SHALL BE ASTM A615 GRADE 60 THE SLAB REINFORCEMENT SHALL BE WELDED WIRE FABRIC MEETING ASTM A185 OR FIBERGLASS FIBER REINFORCEMENT.

#### REINFORCEMENT MAY BE BENT IN THE SHOP OR THE FIELD PROVIDED:

1. REINFORCEMENT IS BENT COLD.
2. THE DIAMETER OF THE BEND, MEASURED ON THE INSIDE OF THE BAR, IS NOT LESS THAN SIX-BAR DIAMETERS.
3. REINFORCEMENT PARTIALLY EMBEDDED IN CONCRETE SHALL NOT BE FIELD BENT.

#### HELIX ANCHOR NOTES:

1. FOR VERY DENSE AND/OR CEMENTED SANDS, COARSE GRAVEL AND COBBLES, CALICHE, PRELOADED SILTS AND CLAYS, USE MINIMUM (2) 4" HELICES WITH MINIMUM 30" EMBEDMENT OR SINGLE 6" HELIX WITH MINIMUM 50" EMBEDMENT.
2. FOR CORAL USE MINIMUM (2) 4" HELICES WITH MINIMUM 30" EMBEDMENT OR SINGLE 6" HELIX WITH MINIMUM 50" EMBEDMENT.
3. FOR MEDIUM DENSE COARSE SANDS, SANDY GRAVELS, VERY STIFF SILTS, AND CLAYS USE MINIMUM (2) 4" HELICES WITH MINIMUM 30 INCH EMBEDMENT OR SINGLE 6" HELIX WITH MINIMUM 50" EMBEDMENT.
4. FOR LOOSE TO MEDIUM DENSE SANDS, FIRM TO STIFF CLAYS AND SILTS ALLUVIAL FILL, USE MINIMUM (2) 6" HELICES WITH MINIMUM 50" EMBEDMENT.
5. FOR VERY LOSE TO MEDIUM DENSE SANDS, FIRM TO STIFFER CLAYS AND SILTS, ALLUVIAL FILL, USE MINIMUM (2) 8" HELICES WITH MINIMUM 60" EMBEDMENT.

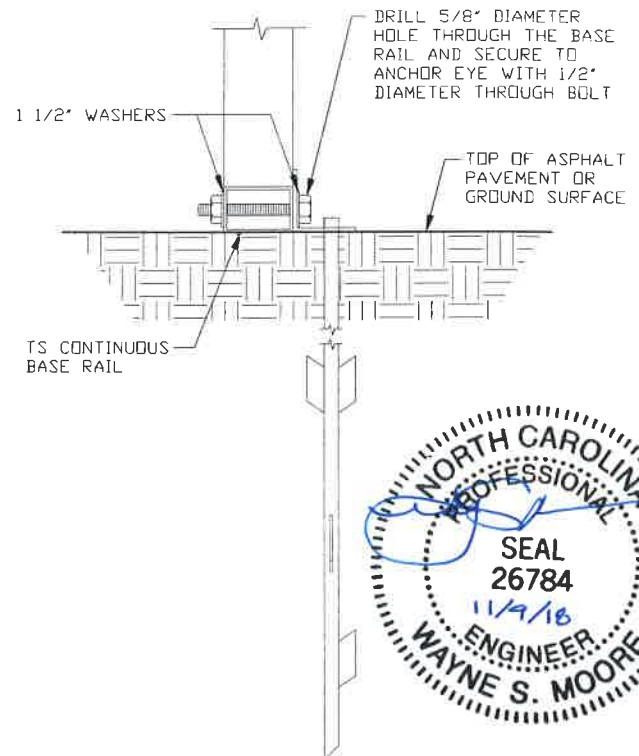

### 3C ASPHALT BASE ANCHORAGE

SCALE: NTS



**MOORE AND ASSOCIATES  
ENGINEERING AND CONSULTING, INC.**

**DRAWN BY:** LT

**CHECKED BY:** PDH

**PROJECT MGR:** WSM

**CLIENT:** NEWMART BUILDERS

NEW MART BUILDERS, INC.

1000 CYCLE LANE  
SOUTH HILL, VA 23970  
30'-0" x 14'-0" ENCLOSED STRUCTURE

**DATE:** 11-5-18

**SHT.** 8

**SCALE:** NTS

**DWG. NO.:** SK-3

**JOB NO.:** 18033S/18113S/18246S

**REV.:** 6

THIS DOCUMENT IS THE PROPERTY OF MOORE AND ASSOCIATES ENGINEERING AND CONSULTING. THE UNAUTHORIZED REPRODUCTION, COPYING, OR OTHERWISE USE OF THIS DOCUMENT IS STRICTLY PROHIBITED AND ANY INFRINGEMENT THEREUPON MAY BE SUBJECT TO LEGAL ACTION.



# BOX EAVE RAFTER END WALL AND SIDE WALL OPENINGS

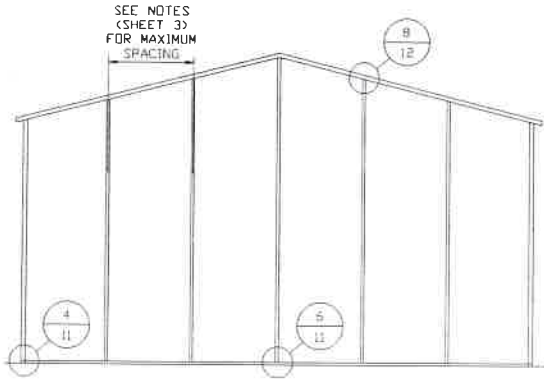

**TYPICAL BOX EAVE RAFTER  
END WALL FRAMING SECTION**

SCALE: NTS

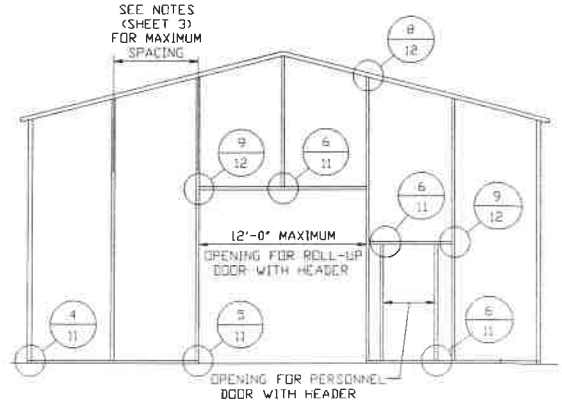

**TYPICAL BOX EAVE RAFTER END  
WALL OPENING FRAMING SECTION**

SCALE: NTS

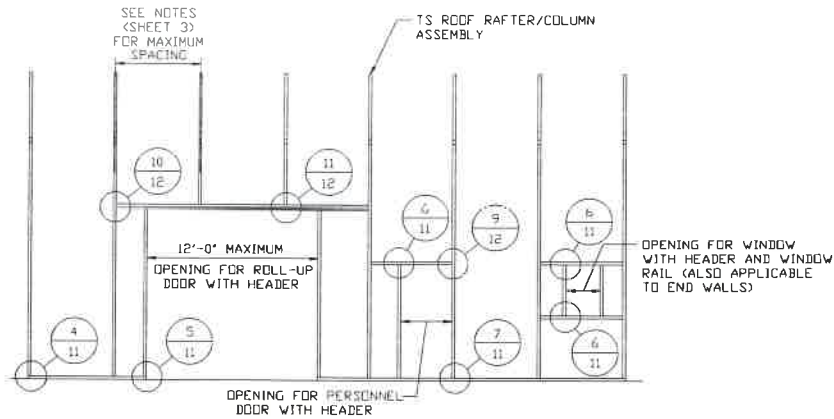

**TYPICAL BOX EAVE RAFTER SIDE  
WALL OPENINGS FRAMING SECTION**

SCALE: NTS

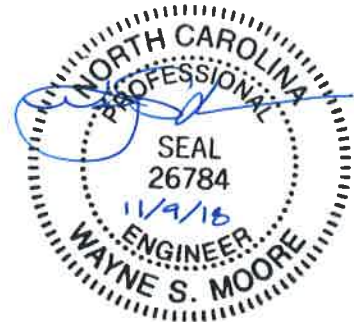

**MOORE AND ASSOCIATES  
ENGINEERING AND CONSULTING, INC.**

**DRAWN BY: LT**

**CHECKED BY: PDH**

**PROJECT MGR: WSM**

**CLIENT: NEWMART BUILDERS**

**NEWMART BUILDERS, INC.**

**1000 CYCLE LANE**

**SOUTH HILL, VA 23970**

**30'-0" x 14'-0" ENCLOSED STRUCTURE**

**DATE: 11-5-18**

**SHT. 9**

**SCALE: NTS**

**DWG. NO: SK-3**

**JOB NO: 18033S/18113S/18246S**

**REV: 6**

THIS DOCUMENT IS THE PROPERTY OF MOORE AND ASSOCIATES ENGINEERING AND CONSULTING. THE UNAUTHORIZED REPRODUCTION, COPYING, OR OTHERWISE USE OF THIS DOCUMENT IS STRICTLY PROHIBITED AND ANY INFRINGEMENT THEREUPON MAY BE SUBJECT TO LEGAL ACTION.

# BOW EAVE RAFTER END WALL AND SIDE WALL OPENINGS

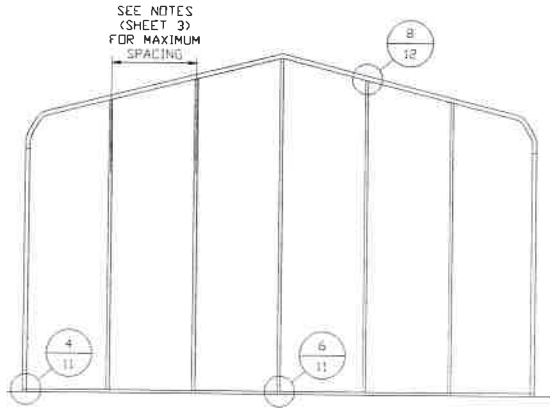

**TYPICAL BOW EAVE RAFTER  
END WALL FRAMING SECTION**

SCALE: NTS

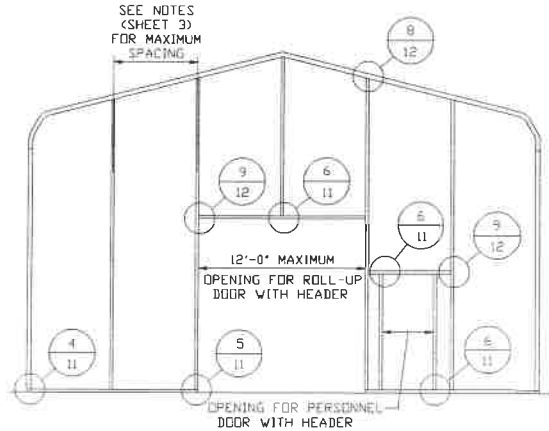

**TYPICAL BOW EAVE RAFTER END  
WALL OPENING FRAMING SECTION**

SCALE: NTS

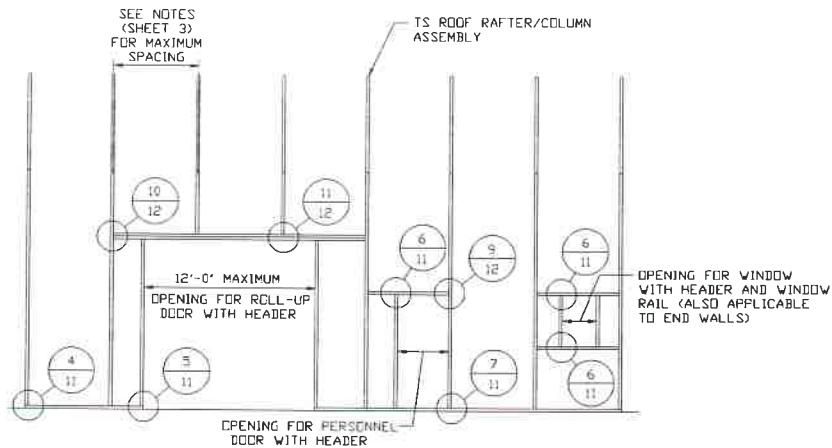

**TYPICAL BOW EAVE RAFTER SIDE  
WALL OPENINGS FRAMING SECTION**

SCALE: NTS



**MOORE AND ASSOCIATES  
ENGINEERING AND CONSULTING, INC.**

DRAWN BY: LT

CHECKED BY: PDH

PROJECT MGR: WSM

CLIENT: NEWMART BUILDERS

NEWMART BUILDERS, INC.

1000 CYCLE LANE

SOUTH HILL, VA 23970

30'-0" x 14'-0" ENCLOSED STRUCTURE

DATE: 11-5-18

SHT. 10

SCALE: NTS

DWG. NO: SK-3

JOB NO:

18033S/18113S/18246S

REV: 6

THIS DOCUMENT IS THE PROPERTY OF MOORE AND ASSOCIATES ENGINEERING AND CONSULTING. THE UNAUTHORIZED REPRODUCTION, COPYING, OR OTHERWISE USE OF THIS DOCUMENT IS STRICTLY PROHIBITED AND ANY INFRINGEMENT THEREUPON MAY BE SUBJECT TO LEGAL ACTION.

# BOX AND BOW EAVE RAFTER WALL OPENING DETAILS

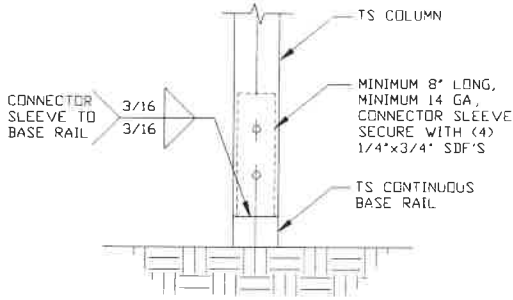

**2** RAFTER COLUMN/BASE RAIL CONNECTION DETAIL  
SCALE: NTS

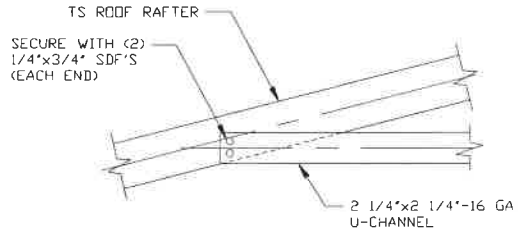

**3** 3'-4' ROOF RAFTER TIE CONNECTION DETAIL  
SCALE: NTS

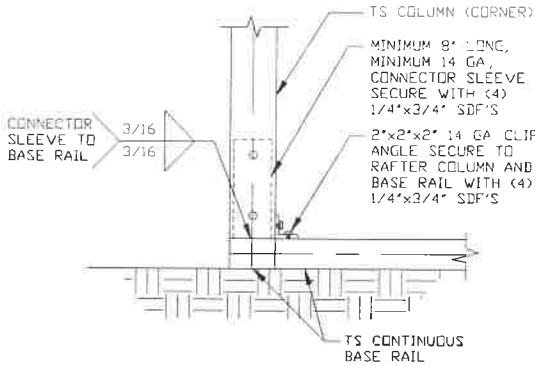

**4** END COLUMN/BASE RAIL CONNECTION DETAIL  
SCALE: NTS

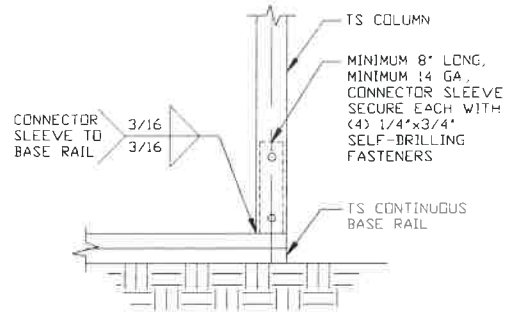

**5** COLUMN/BASE RAIL CONNECTION DETAIL  
SCALE: NTS

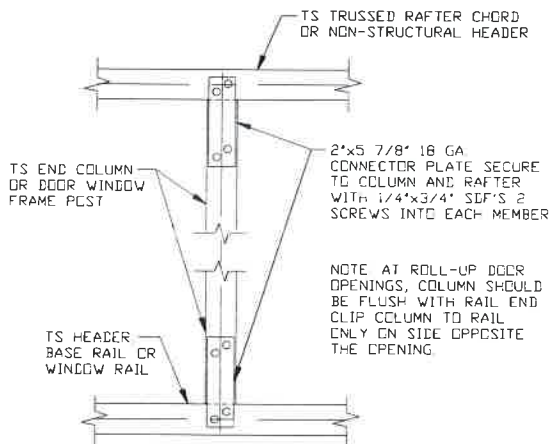

**6** COLUMN TO WINDOW RAIL CONNECTION DETAIL  
SCALE: NTS

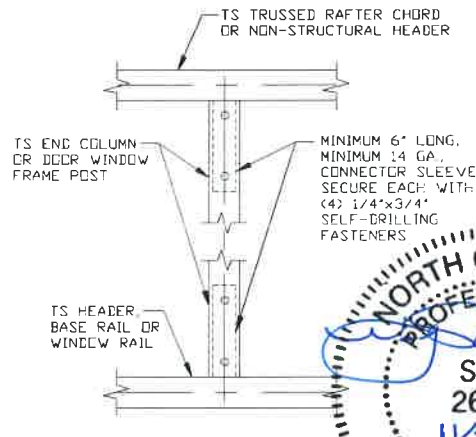

**7** COLUMN TO HEADER OR BASE RAIL CONNECTION DETAIL  
SCALE: NTS

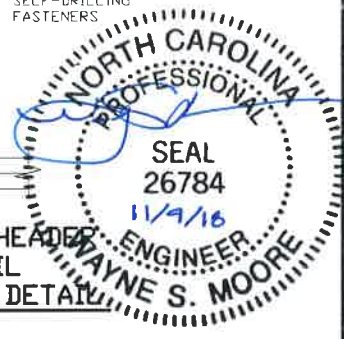

**MOORE AND ASSOCIATES  
ENGINEERING AND CONSULTING, INC.**

**DRAWN BY: LT**  
**CHECKED BY: PDH**

**NEWMART BUILDERS, INC.**  
1000 CYCLE LANE  
SOUTH HILL, VA 23970  
30'-0" x 14'-0" ENCLOSED STRUCTURE

THIS DOCUMENT IS THE PROPERTY OF MOORE AND ASSOCIATES ENGINEERING AND CONSULTING. THE UNAUTHORIZED REPRODUCTION, COPYING, OR OTHERWISE USE OF THIS DOCUMENT IS STRICTLY PROHIBITED AND ANY INFRINGEMENT THEREUPON MAY BE SUBJECT TO LEGAL ACTION.

**PROJECT MGR: VSM**  
**CLIENT: NEWMART BUILDERS**

**DATE: 11-5-18**  
**SHT. 11**

**SCALE: NTS**  
**DWG. NO: SK-3**  
**JOB NO: 18033S/18113S/18246S**  
**REV: 6**

# BOX AND BOW EAVE RAFTER WALL OPENING DETAILS

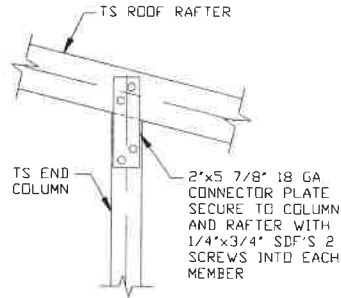

**8** RAFTER TO CHORD CONNECTION DETAIL  
SCALE: NTS

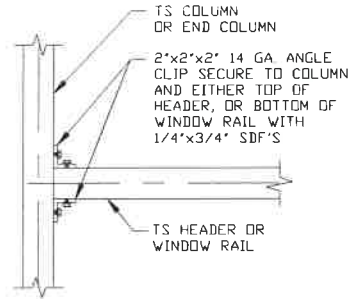

**9** COLUMN OR WINDOW RAIL TO POST CONNECTION DETAIL  
SCALE: NTS

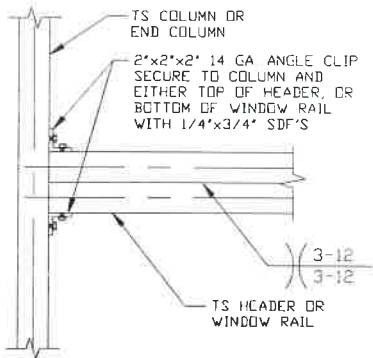

**10** DOUBLE HEADER TO COLUMN CONNECTION DETAIL  
SCALE: NTS

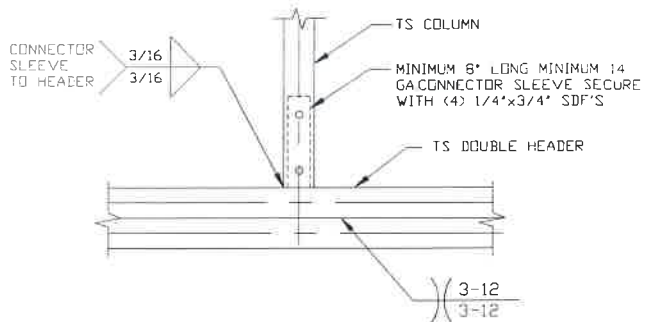

**11** COLUMN/DOUBLE HEADER CONNECTION DETAIL  
SCALE: NTS

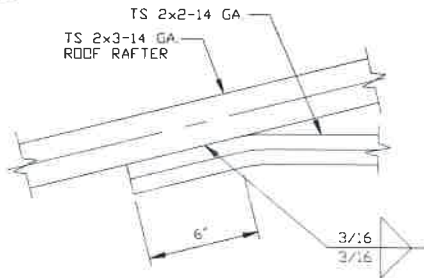

**12A** 6'-0" ROOF RAFTER TIE CONNECTION DETAIL  
SCALE: NTS

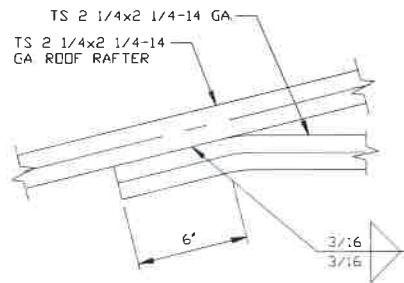

**12B** 6'-0" ROOF RAFTER TIE CONNECTION DETAIL  
SCALE: NTS



**MOORE AND ASSOCIATES  
ENGINEERING AND CONSULTING, INC.**

DRAWN BY: LT

CHECKED BY: PDH

PROJECT MGR: WSM

CLIENT: NEWMART BUILDERS

NEWMART BUILDERS, INC.  
1000 CYCLE LANE  
SOUTH HILL, VA 23970  
30'-0"x14'-0" ENCLOSED STRUCTURE

DATE: 11-5-18

SHT. 12

SCALE: NTS

DWG. NO: SK-3

JOB NO:  
18033S/18113S/18246S

REV: 6

THIS DOCUMENT IS THE PROPERTY OF MOORE AND ASSOCIATES ENGINEERING AND CONSULTING. THE UNAUTHORIZED REPRODUCTION, COPYING, OR OTHERWISE USE OF THIS DOCUMENT IS STRICTLY PROHIBITED AND ANY INFRINGEMENT THEREUPON MAY BE SUBJECT TO LEGAL ACTION.



# BOX EAVE RAFTER LEAN-TO OPTIONS

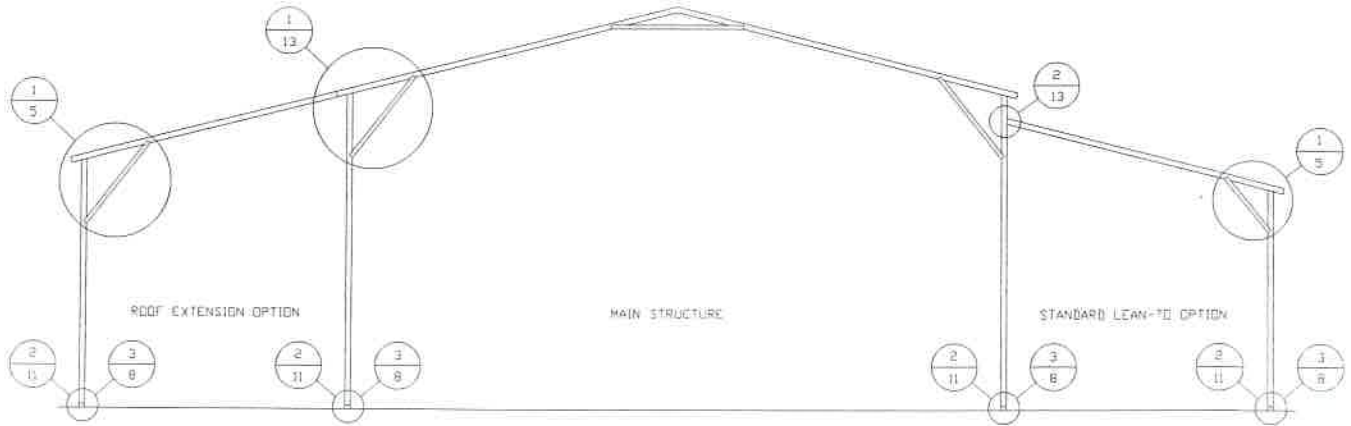

**TYPICAL BOX EAVE RAFTER LEAN-TO OPTIONS FRAMING SECTION (BOTH OPTIONS SHOWN)**

SCALE: NTS

MAXIMUM WIDTH OF STANDARD LEAN-TO IS 12'-0"

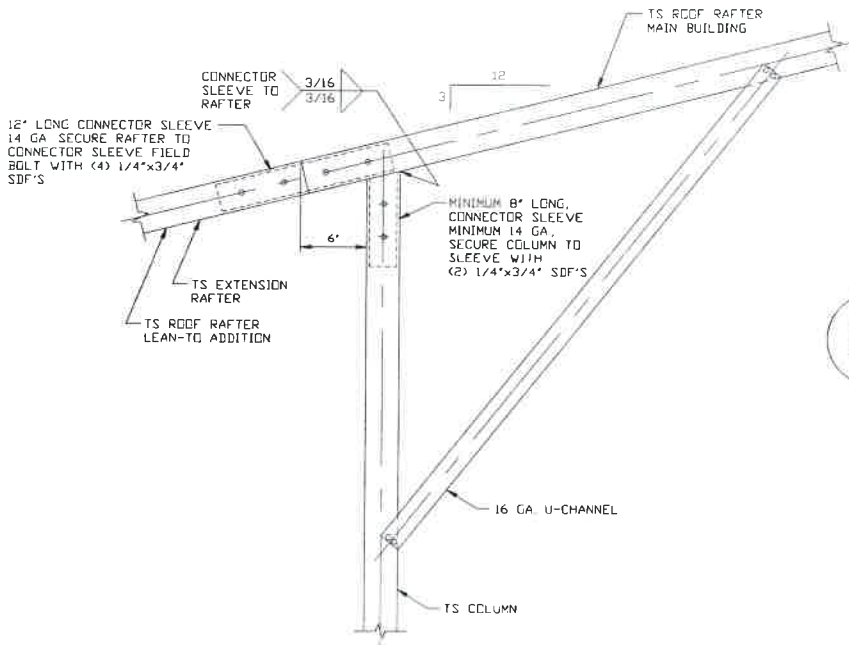

1

**SIDE EXTENSION RAFTER/COLUMN DETAIL**

SCALE: NTS

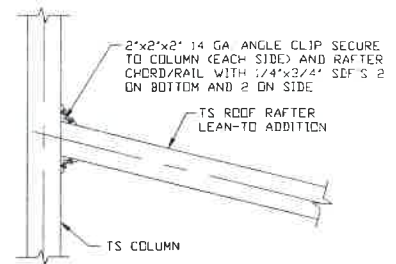

2A

**LEAN-TO RAFTER TO RAFTER COLUMN CONNECTION DETAIL**

SCALE: NTS

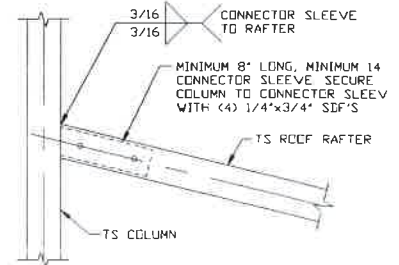

2B

**LEAN-TO RAFTER TO RAFTER COLUMN CONNECTION DETAIL**

SCALE: NTS



**MOORE AND ASSOCIATES  
ENGINEERING AND CONSULTING, INC.**

DRAWN BY: LT

CHECKED BY: PDH

PROJECT MGR: WSM

CLIENT: NEWMART BUILDERS

NEWMART BUILDERS, INC.

1000 CYCLE LANE

SOUTH HILL, VA 23970

30'-0"x14'-0" ENCLOSED STRUCTURE

DATE: 11-5-18

SHT. 13

SCALE: NTS

DWG. NO: SK-3

JOB NO:

18033S/18113S/18246S

REV: 6

THIS DOCUMENT IS THE PROPERTY OF MOORE AND ASSOCIATES ENGINEERING AND CONSULTING. THE UNAUTHORIZED REPRODUCTION, COPYING, OR OTHERWISE USE OF THIS DOCUMENT IS STRICTLY PROHIBITED AND ANY INFRINGEMENT THEREUPON MAY BE SUBJECT TO LEGAL ACTION.

# BOW RAFTER LEAN-TO OPTIONS

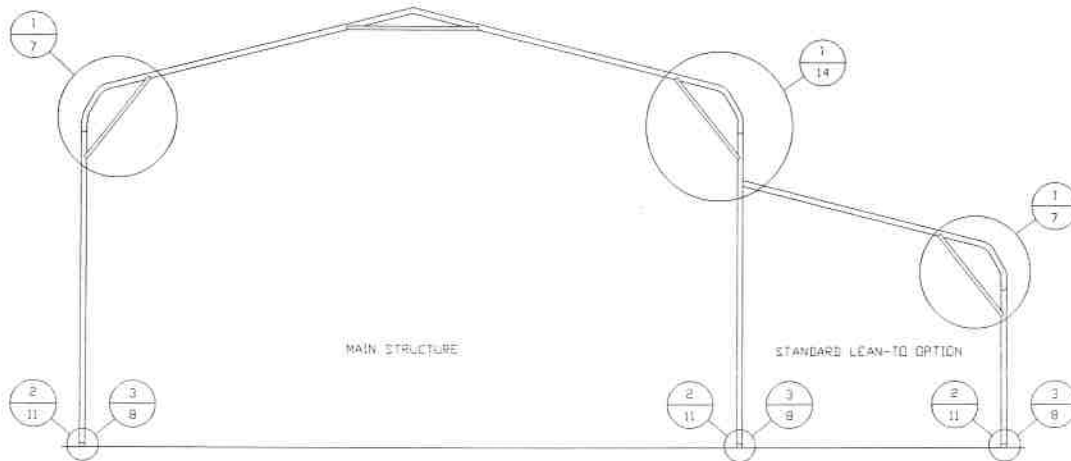

## TYPICAL BOW RAFTER LEAN-TO OPTION FRAMING SECTION

SCALE: NTS  
 MAXIMUM WIDTH OF STANDARD LEAN-TO IS 12'-0"

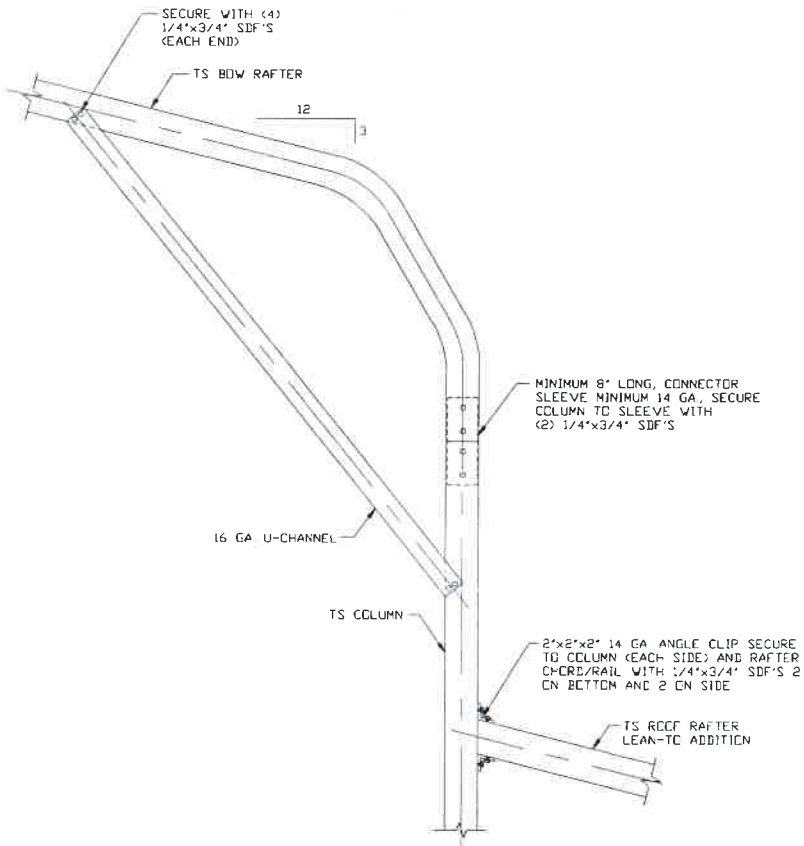

### LEAN-TO RAFTER TO RAFTER COLUMN CONNECTION DETAIL

SCALE: NTS

1A

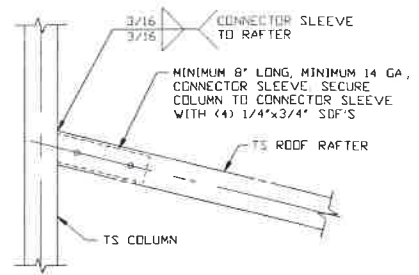

### LEAN-TO RAFTER TO RAFTER COLUMN CONNECTION DETAIL

SCALE: NTS

1B



**MOORE AND ASSOCIATES  
 ENGINEERING AND CONSULTING, INC.**

DRAWN BY: LT

CHECKED BY: PDH

PROJECT MGR: VSM

CLIENT: NEWMART BUILDERS

NEWMART BUILDERS, INC.  
 1000 CYCLE LANE  
 SOUTH HILL, VA 23970  
 30'-0"x14'-0" ENCLOSED STRUCTURE

DATE: 11-5-18

SHT. 14

SCALE: NTS

DWG. NO: SK-3

JOB NO: 18033S/18113S/18246S

REV: 6

THIS DOCUMENT IS THE PROPERTY OF MOORE AND ASSOCIATES ENGINEERING AND CONSULTING. THE UNAUTHORIZED REPRODUCTION, COPYING, OR OTHERWISE USE OF THIS DOCUMENT IS STRICTLY PROHIBITED AND ANY INFRINGEMENT THEREUPON MAY BE SUBJECT TO LEGAL ACTION.

# BOX EAVE RAFTER VERTICAL ROOF/SIDING OPTION

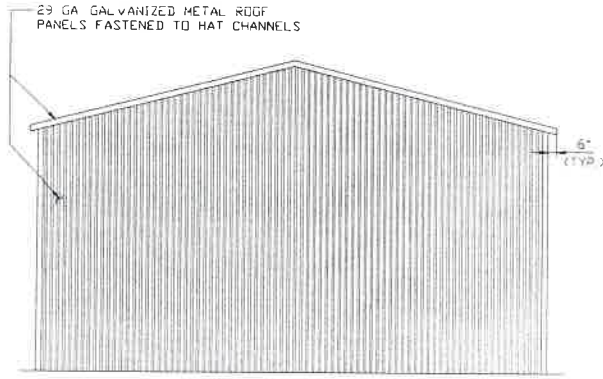

**TYPICAL END ELEVATION  
VERTICAL ROOF/SIDING**  
SCALE: NTS

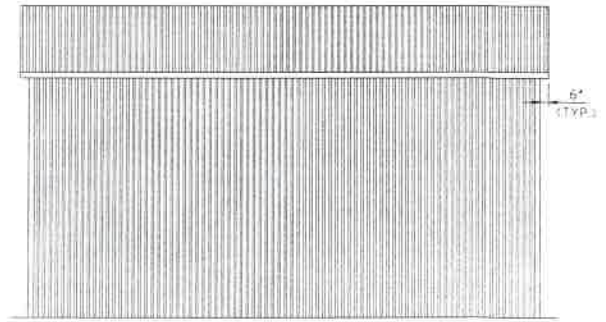

**TYPICAL SIDE ELEVATION  
VERTICAL ROOF/SIDING OPTION**  
SCALE: NTS

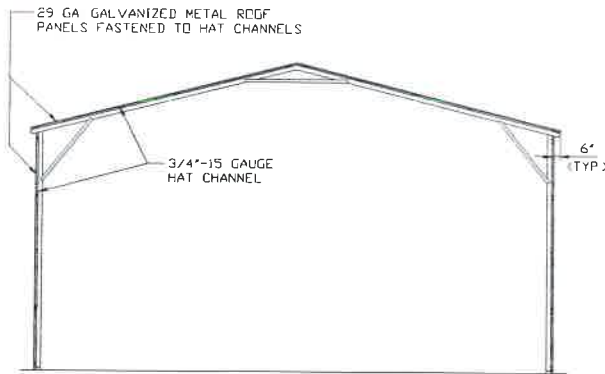

**TYPICAL SECTION  
VERTICAL ROOF/SIDING OPTION**  
SCALE: NTS

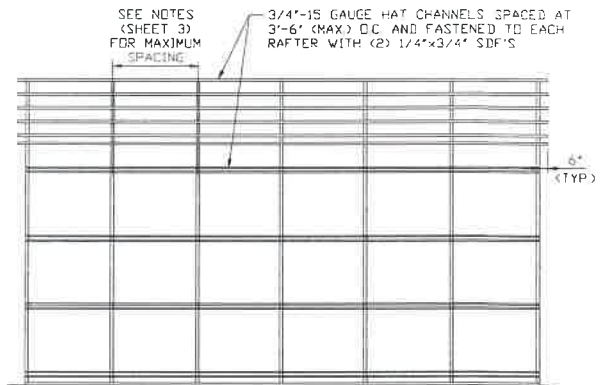

**TYPICAL FRAMING SECTION  
VERTICAL ROOF/SIDING OPTION**  
SCALE: NTS

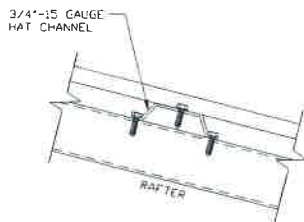

**PANEL ATTACHMENT**  
(ALTERNATE FOR VERTICAL ROOF PANELS)  
SCALE: NTS

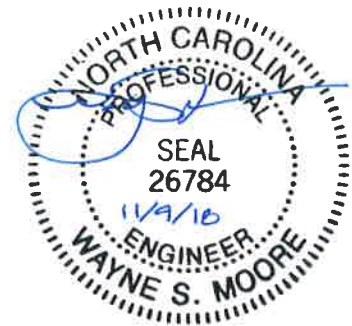

**MOORE AND ASSOCIATES  
ENGINEERING AND CONSULTING, INC.**

**DRAWN BY: LT**

**CHECKED BY: PDH**

**PROJECT MGR: WSM**

**CLIENT: NEWMART BUILDERS**

**NEWMART BUILDERS, INC.**

1000 CYCLE LANE

SOUTH HILL, VA 23970

30'-0" x 14'-0" ENCLOSED STRUCTURE

**DATE: 11-5-18**

**SHT. 15**

**SCALE: NTS**

**DWG. NO: SK-3**

**JOB NO:**

18033S/18113S/18246S

**REV: 6**

THIS DOCUMENT IS THE PROPERTY OF MOORE AND ASSOCIATES ENGINEERING AND CONSULTING. THE UNAUTHORIZED REPRODUCTION, COPYING, OR OTHERWISE USE OF THIS DOCUMENT IS STRICTLY PROHIBITED AND ANY INFRINGEMENT THEREUPON MAY BE SUBJECT TO LEGAL ACTION.

## ADDITIONAL BASE RAIL ANCHORAGE OPTION

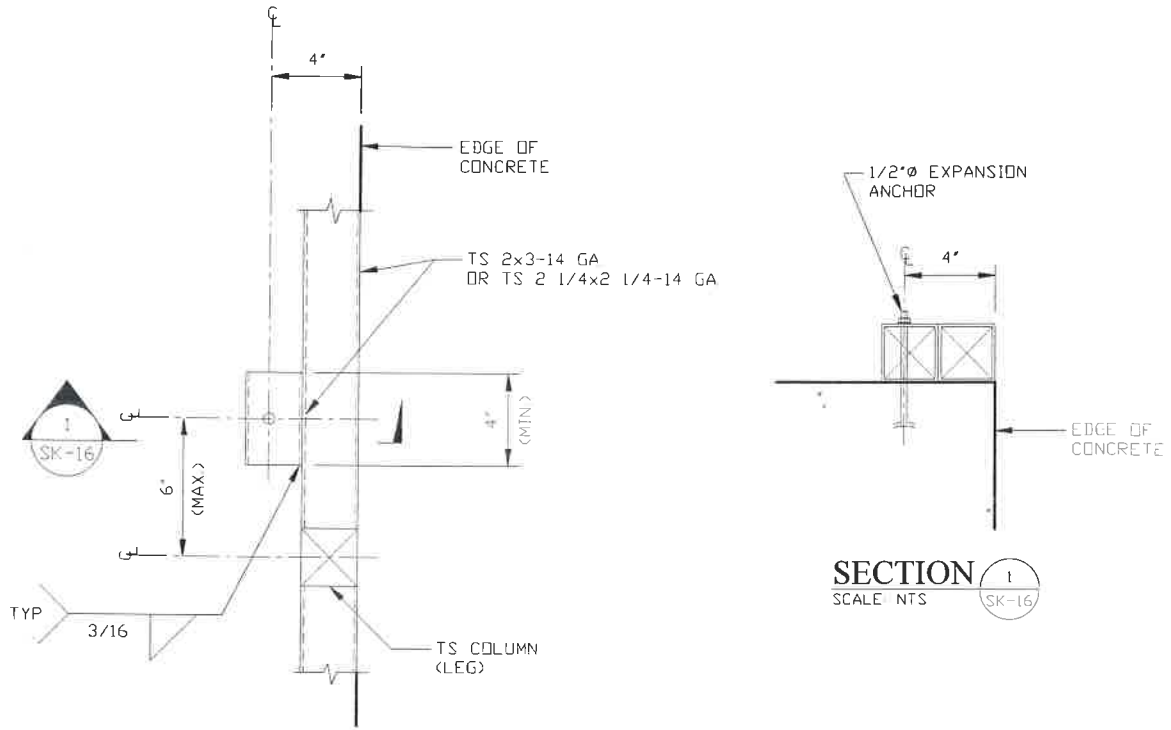

**TYPICAL ANCHOR DETAIL WHEN BASE RAIL IS NEAR EDGE OF CONCRETE**

SCALE: NTS



**MOORE AND ASSOCIATES  
ENGINEERING AND CONSULTING, INC.**

DRAWN BY: LT

CHECKED BY: PDH

PROJECT MGR: WSM

CLIENT: NEWMART BUILDERS

NEWMART BUILDERS, INC.  
1000 CYCLE LANE  
SOUTH HILL, VA 23970  
30'-0" x 14'-0" ENCLOSED STRUCTURE

DATE: 11-5-18

SCALE: NTS

JOB NO:  
18033S/18113S/18246S

SHT. 16

DWG. NO: SK-3

REV: 6

THIS DOCUMENT IS THE PROPERTY OF MOORE AND ASSOCIATES ENGINEERING AND CONSULTING. THE UNAUTHORIZED REPRODUCTION, COPYING, OR OTHERWISE USE OF THIS DOCUMENT IS STRICTLY PROHIBITED AND ANY INFRINGEMENT THEREUPON MAY BE SUBJECT TO LEGAL ACTION.