

Date: April 5, 2022  
Project: Smith Residence  
Address: 182 Winged Foot Dr  
Bunnlevel, NC 28323

## Floor Support Analysis

This report is prepared for Southeast Foundation Repair (contractor) by FDN Engineering (engineer). Floor support jacks (SmartJacks) are specified for installation at the above referenced project. The support system is intended to stabilize and potentially lift the existing floor structure – reducing deflections in the floor and supporting the vertical loads tributary to the support. Load requirements for the SmartJacks were calculated at areas identified by the contractor. See page 2 for engineering analysis assumptions and results. See pages 3 and 4 for details of the floor support system. See page 5 for a layout of the floor supports on a footprint of the structure.

To the best of my professional knowledge, belief, and opinion, the design of the floor structure support system meets the structural requirements of the 2015 International Residential Code to the extent that it applies to our scope of work.

Upon completion of floor support system, the contractor shall supply engineer a log of the installed locations and lift of the SmartJacks. Engineer will evaluate the log and prepare a letter of completion.



FDN Engineering, LLC  
2412 N 179th St.  
Omaha, NE 68116  
(402) 739-9642

## SmartJack Project Assumptions (contractor to confirm assumptions):

1. Structure is two-story, single family residential with wood-frame floors.
2. Soil bearing pressure at the site is a minimum of 2,000 psf.
3. SmartJack model size 350 is specified.
4. SmartJacks and supplemental girders assumed to support interior load-bearing walls or columns.
5. Contractor will install footings, SmartJacks, supplemental girders and all related components per the support manufacturer's installation instructions and according to their technical specs.
6. Contractor to select support base that adequately transfers load from SmartJack to soil.
7. Supplemental support girders are restrained against lateral rotation at an interval equal to or less than the SmartJack spacing.
8. SmartJacks supporting existing girders are not spaced farther than the original/existing supports; and the existing girder/joist's condition is adequate to support the new compression load.
9. Supports are not placed on sinkholes.
10. Where supplemental girders are specified, use HSS 4.0" square tube x 0.12" wall (ASTM A500 Gr. C).
11. The design assumes the original structure was constructed of conventional means and methods.

## SmartJack Analysis Notes and Results:

12. Interior floor load is assumed to not exceed 55 psf nominal load (15 psf DL + 40 psf LL), per Code.
13. SmartJacks are designed to support axial compression load only; with a max height of 9'-0".
14. Maximum total load on SmartJack is **7,900 lbs.**
15. SmartJack spacing along the supported girder (or tributary length) shall not exceed **5'-0" O.C.**

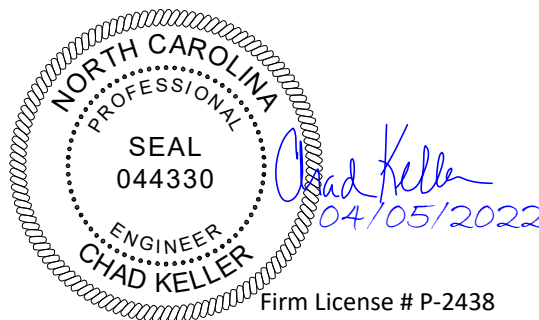

Note:  
See manufacturer's specifications for more information regarding the post, top bracket and base plate's material and capacities.

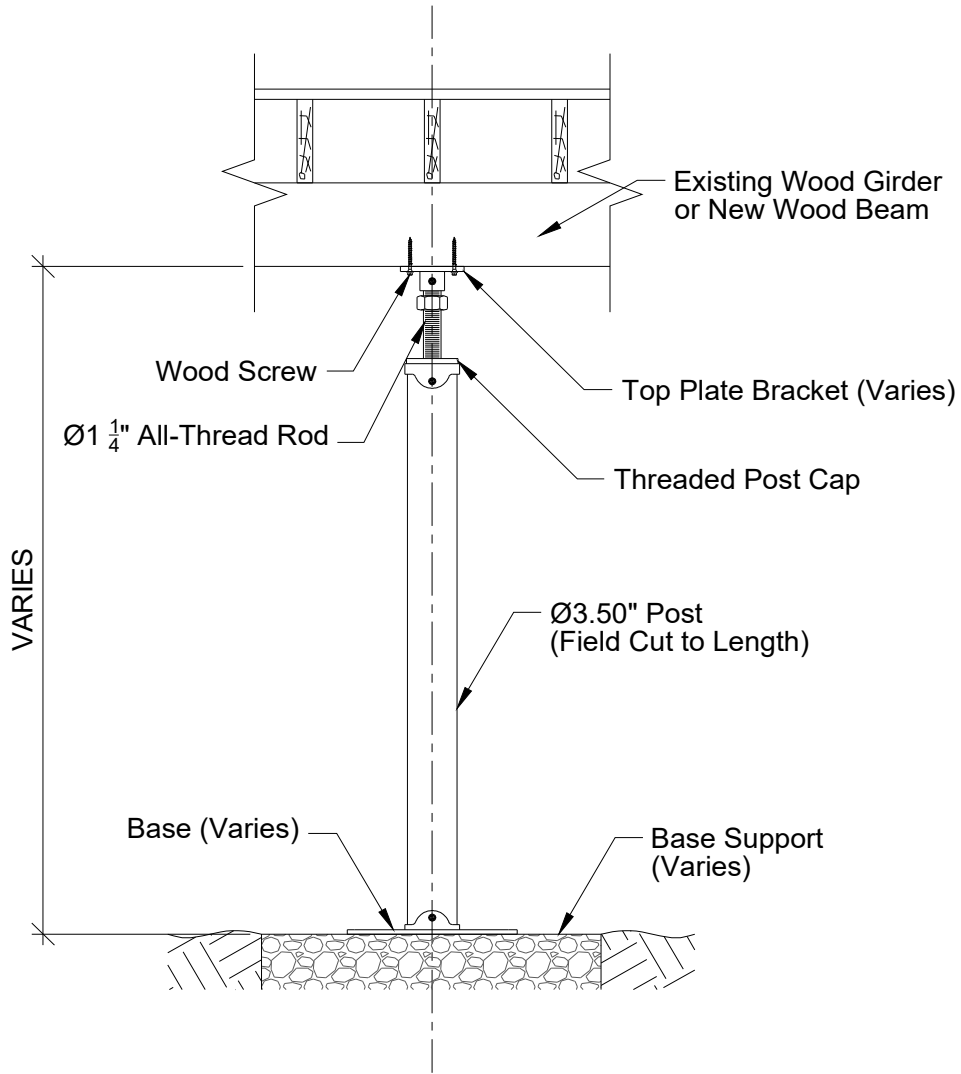

General SmartJack Detail  
Shown with Top Plate for Wood Attachment  
(See Following Page for Acceptable Variations)

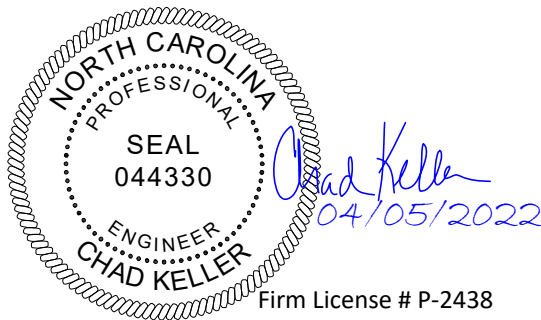

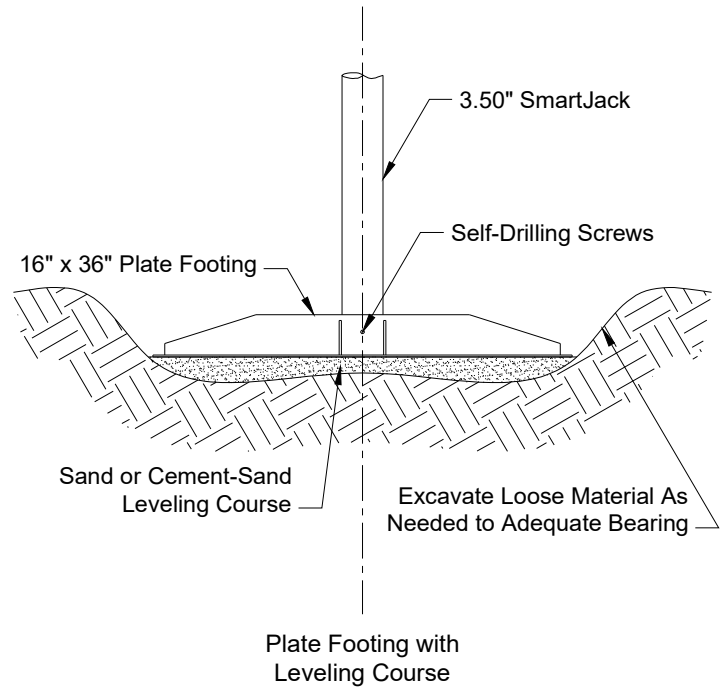
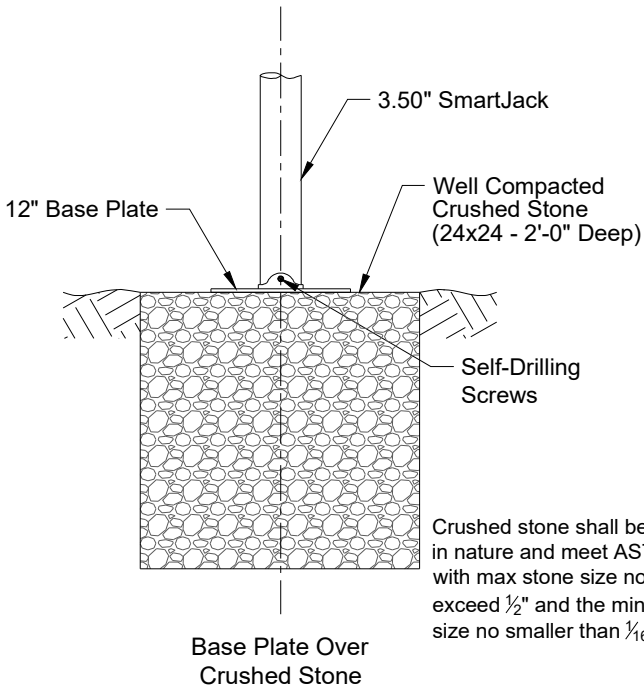

All above variations shown are structurally acceptable and may be used at the contractor's discretion based on field conditions.

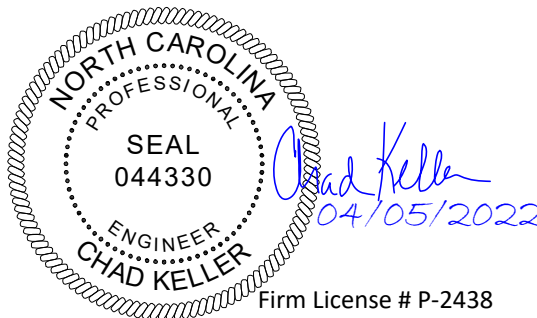

**LEGEND:**

- # ● Indicates SmartJack and Mark Number
- ▒ Existing Pier
- Existing Girder

**SmartJack Notes:**

1. Residential construction, two-story.
2. Layout of (4) SmartJacks Model 350 for floor support at **5'-0" O.C., max.**
3. Install per SmartJack manufacturer's instructions and technical specifications.
4. Notify engineer if design assumptions are discovered inaccurate.

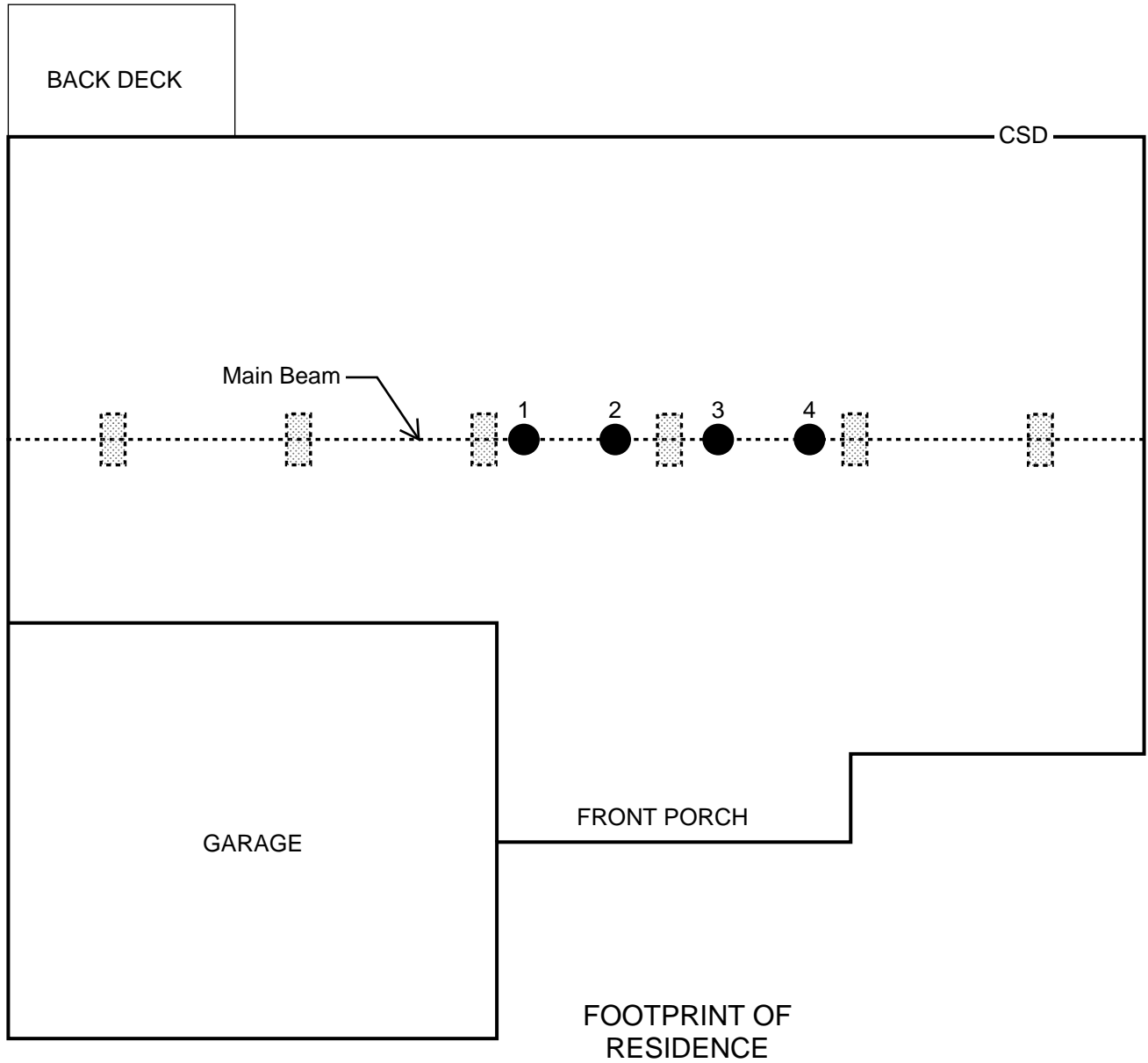

DRAWING NOT TO SCALE

**Project:**

Smith Residence  
182 Winged Foot Dr  
Bunnlevel, NC 28323

**FDN Engineering, LLC**

2412 N 179th St.  
Omaha, NE 68116  
(402) 739-9642

