

Cody Johnston, PE  
 Stonewall Structural Engineering, PLLC  
 4800 Falls of Neuse Rd. #120  
 Raleigh, NC 27609  
 (919)407-8663



Brett Vambell  
 Tarheel Basement Systems  
 3333 Air Park Rd.  
 Fuquay-Varina, NC 27526

Re: Structural Observation — 62 Angel Oak Drive, Bunnlevel, NC 28323

Mr. Vambell,

At your request, on February 3, 2022 we performed a review of the structural plan proposed by *Tarheel Basement Systems* for the foundation stabilization work at the Bunnlevel residence noted above. The structure is a conventionally framed, detached, single family residence with raised first floor framing over a pier/girder foundation system with perimeter masonry foundation walls (*see picture 1*).

Our observations are listed below. Indicators such as “left,” “right,” “front,” and “back” are referenced as viewing the front of the home.

#### FOUNDATION MOVEMENT

- Minor cracks were noted in the parging on the left, right, and back sides of the home (*see pictures 2-3 for examples*).
  - Measurement by laser level from the bottom of the floor joists indicated that the that the back-right corner of the home was down as much as approximately 1” relative to back-left corner of the home.
  - Additional measurement by laser level from the top of the foundation wall indicated that the foundation wall along the back of the home was level within ¼”.
    - Closer examination of the floor joists revealed that floor joists and the rim band to the right of the fireplace bump out were out of contact with the knee wall top plates due to the knee wall being shorter on the right side of the fireplace bump out compared to the knee wall on the left side of the fireplace bump out (*see pictures 4-5 for examples*).

We recommend the following work be performed by a qualified general contractor:

- To prevent future movement of the floor system, joists and the rim band along the back of the home should be shimmed using tight fit shim material to the tops of the knee wall top plates.
- To prevent future settlement of the back and right portions of the home, the proposed series of (12) galvanized steel helical piers or push piers may be installed.
  - Helical piers should be installed to a torque capable of developing 20 kips of axial load, or to refusal. Push piers should be driven until engagement of the structure with lift indicating adequate depth/frictional resistance along the shafts of the piers
  - The contractor should locate and avoid utilities prior to work

- Avoid installing piers under windows and doors
- Install piers at approximately 6' on center and at the approximate locations shown in the attached repair schematic.

The above-listed determinations were made in accordance with common engineering principles and the intent of the 2018 edition of the *North Carolina Residential Building Code*. Sequencing, and means and methods of construction are considered to be beyond the scope of this report. Contractor is to provide adequate temporary shoring prior to cutting or removing any structural load-bearing elements. All work is to conform to applicable provisions of current building standards. Please feel free to contact us, should you have any questions or concerns regarding this matter.

Sincerely,  
Cody Johnston, PE  
Stonewall Structural Engineering, PLLC  
Lic. #P-0951

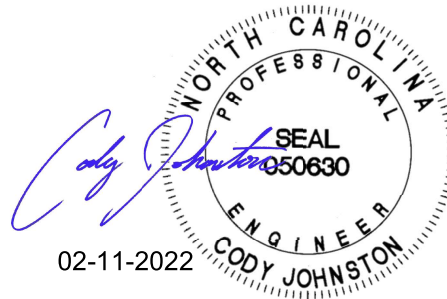

**PICTURE ADDENDUM**



*Picture 1 – 62 Angel Oak Drive  
Bunnlevel, NC*



*Picture 2 – Example of parging cracks*



*Picture 3 – Example of parging cracks*



*Picture 4 – Floor joists and rim band out of contact with knee wall top plates*



*Picture 5 – Floor joists and rim band out of contact with knee wall top plates*

**SCHEMATIC ADDENDUM**

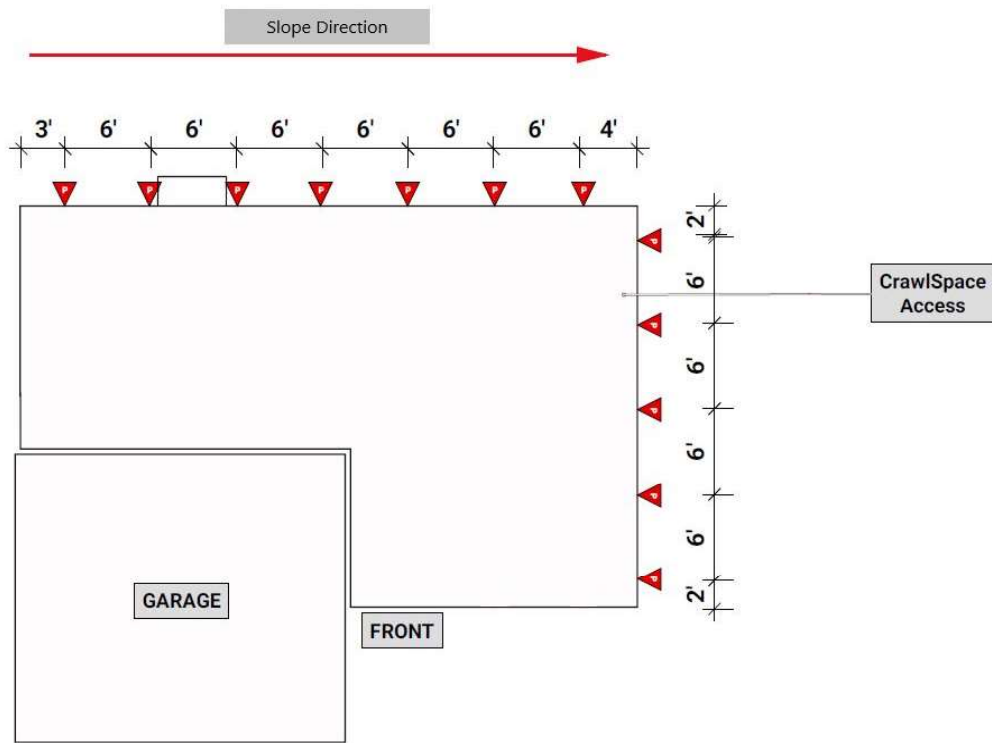

*Repair schematic*

