



This room may not enclosed a bedroom egress route

GREAT DAY IMPROVEMENTS, RALEIGH GARCIA RESIDENCE

MINIMUM DESIGN LOADS: PER 2018 NC RESIDENTIAL BUILDING CODE / 2015 IRC WITH NC AMENDMENTS

SUNROOM CATEGORY II (PER 2015 IRC R301.2.1.1.1 & AAMA / NPEA / NSA 2100)

DEAD LOADS:  
 1. ROOF: 15 PSF  
 2. WALLS: 20 PSF  
 3. FLOOR: 10 PSF

SNOW LOADS: GROUND SNOW LOAD 20 PSF

ULTIMATE DESIGN WIND SPEED: 120 MPH, 3 SEC. GUSTS

LIVE LOADS:  
 1. ROOF: 20 PSF  
 2. FLOOR: 40 PSF

THIS SUNROOM IS NOT TO BE CONDITIONED OR USED AS A PERMANENT LIVING AREA.

- NOTES:
1. ALLVIEW (AAS) SUNROOM; WHITE IN COLOR
  2. CONSTRUCT SUNROOM ON NEW DECK
  3. NO HEAT BY GDI; ELECTRICAL BY GDI
  4. ALL CONCRETE TO BE 3000 PSI MINIMUM
  5. ALL DECK LUMBER IS PRESSURE TREATED SYP #2 OR BETTER
  6. THIS SUNROOM IS CONSIDERED AS NON-CONDITIONED SPACE, EXEMPT FROM ENERGY REQUIREMENTS (PER 2015 IRC SECTION N1102.1, NOTE 2)

DRAWING #	DESCRIPTION
1	COVER
2	ELEVATION "B" WALL
3	ELEVATION "A" & "C" WALL
4	FOUNDATION PLAN
5	ELECTRICAL PLAN
6	FLOOR PLAN
7	ROOF PLAN
8	SYSTEM DETAILS
9	SYSTEM DETAILS

ALLOWABLE SOIL PRESSURE CONSIDERED (PRESUMPTIVE) = 2000 PSF

NOTE: THIS STRUCTURE HAS BEEN EVALUATED FOR VERTICAL AND LATERAL LOADS REQUIRED BY THE 2018 NORTH CAROLINA RESIDENTIAL BUILDING CODE.

SQUARE FOOTAGE OF SUNROOM = 138

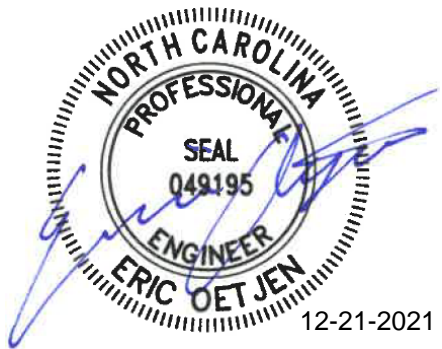

ERIC OETJEN, P.E., M. ENG.  
 NC. PROFESSIONAL ENGINEER (NC. LIC. #049195)  
 5 GREENE STREET  
 FORT THOMAS, KY. 41075  
 PH. # 859-393-9049

LOCATION  
 GDI - RALEIGH  
 951 AVIATION PKWY, SUITE 1000  
 MORRISVILLE, NC 27560  
 984-212-8850

CHRISTINA GARCIA  
 300 CRESTHAVEN DRIVE  
 SANFORD, NC 27332  
 JOB #20445

DATE	12/20/21
DRAWN	MTS
SCALE	1/4" = 1'-0"
SHEET	1 OF 9

THIS DRAWING IS PROPERTY OF GREAT DAY IMPROVEMENTS, LLC., AND DUPLICATION OF THIS DRAWING WITHOUT OUR EXPRESSED WRITTEN CONSENT IS PROHIBITED. ALL RIGHTS RESERVED.

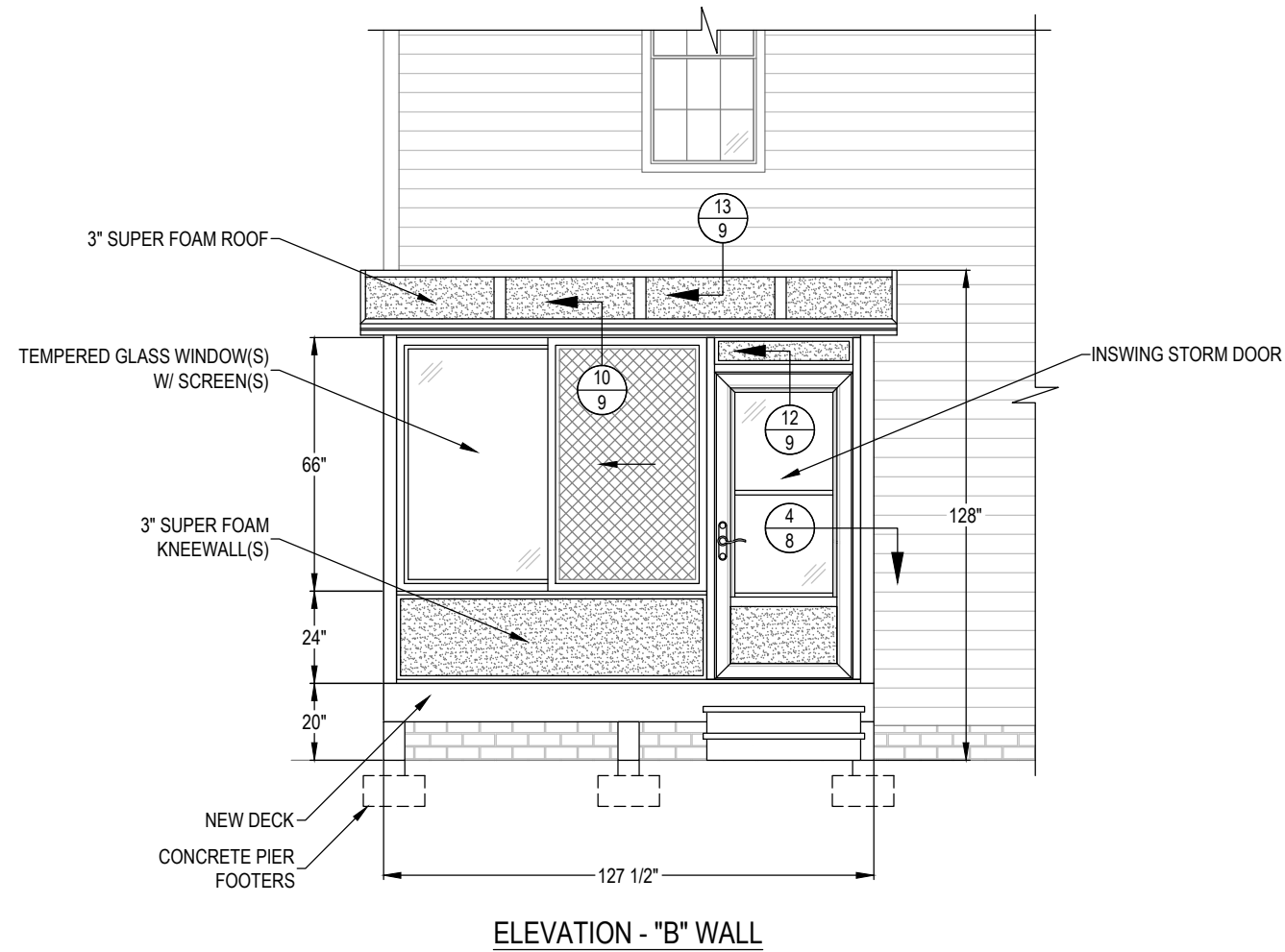
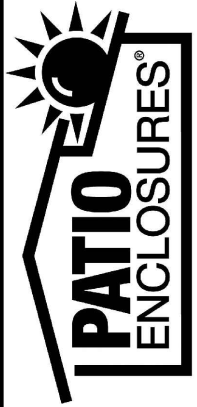

ELEVATION - "B" WALL



ERIC OETJEN, P.E., M. ENG.  
 NC. PROFESSIONAL ENGINEER (NC. LIC. #049195)  
 5 GREENE STREET  
 FORT THOMAS, KY. 41075  
 PH. # 859-393-9049

LOCATION  
 GDI - RALEIGH  
 951 AVIATION PKWY, SUITE 1000  
 MORRISVILLE, NC 27560  
 984-212-8850

CHRISTINA GARCIA  
 300 CRESTHAVEN DRIVE  
 SANFORD, NC 27332  
 JOB #20445

--	--	--	--

DATE  
 12/20/21

DRAWN  
 MTS

SCALE  
 1/4" = 1'-0"

SHEET  
 2 OF 9

THIS DRAWING IS PROPERTY OF GREAT DAY IMPROVEMENTS, LLC., AND DUPLICATION OF THIS DRAWING WITHOUT OUR EXPRESSED WRITTEN CONSENT IS PROHIBITED. ALL RIGHTS RESERVED



BY GREAT DAY IMPROVEMENTS, LLC

LOCATION

GDI - RALEIGH  
951 AVIATION PKWY, SUITE 1000  
MORRISVILLE, NC 27560  
984-212-8850

CHRISTINA GARCIA  
300 CRESTHAVEN DRIVE  
SANFORD, NC 27332  
JOB #20445

DATE  
12/20/21

DRAWN  
MTS

SCALE  
1/4" = 1'-0"

SHEET  
3 OF 9

THIS DRAWING IS PROPERTY OF GREAT DAY IMPROVEMENTS, LLC., AND DUPLICATION OF THIS DRAWING WITHOUT OUR EXPRESSED WRITTEN CONSENT IS PROHIBITED. ALL RIGHTS RESERVED.

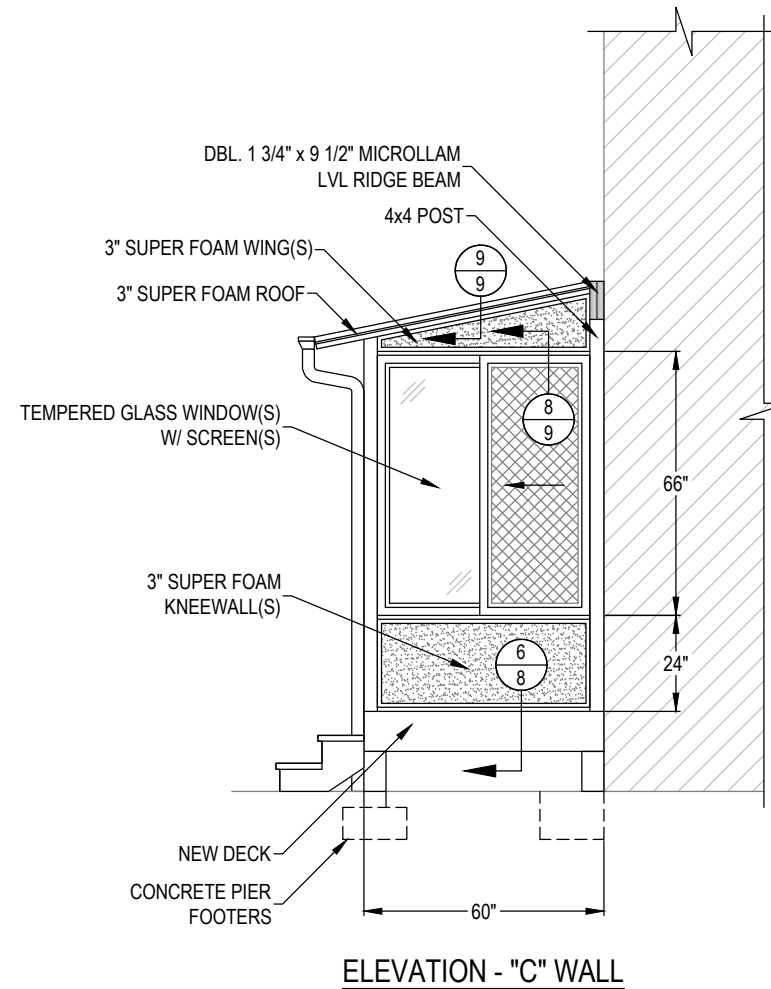
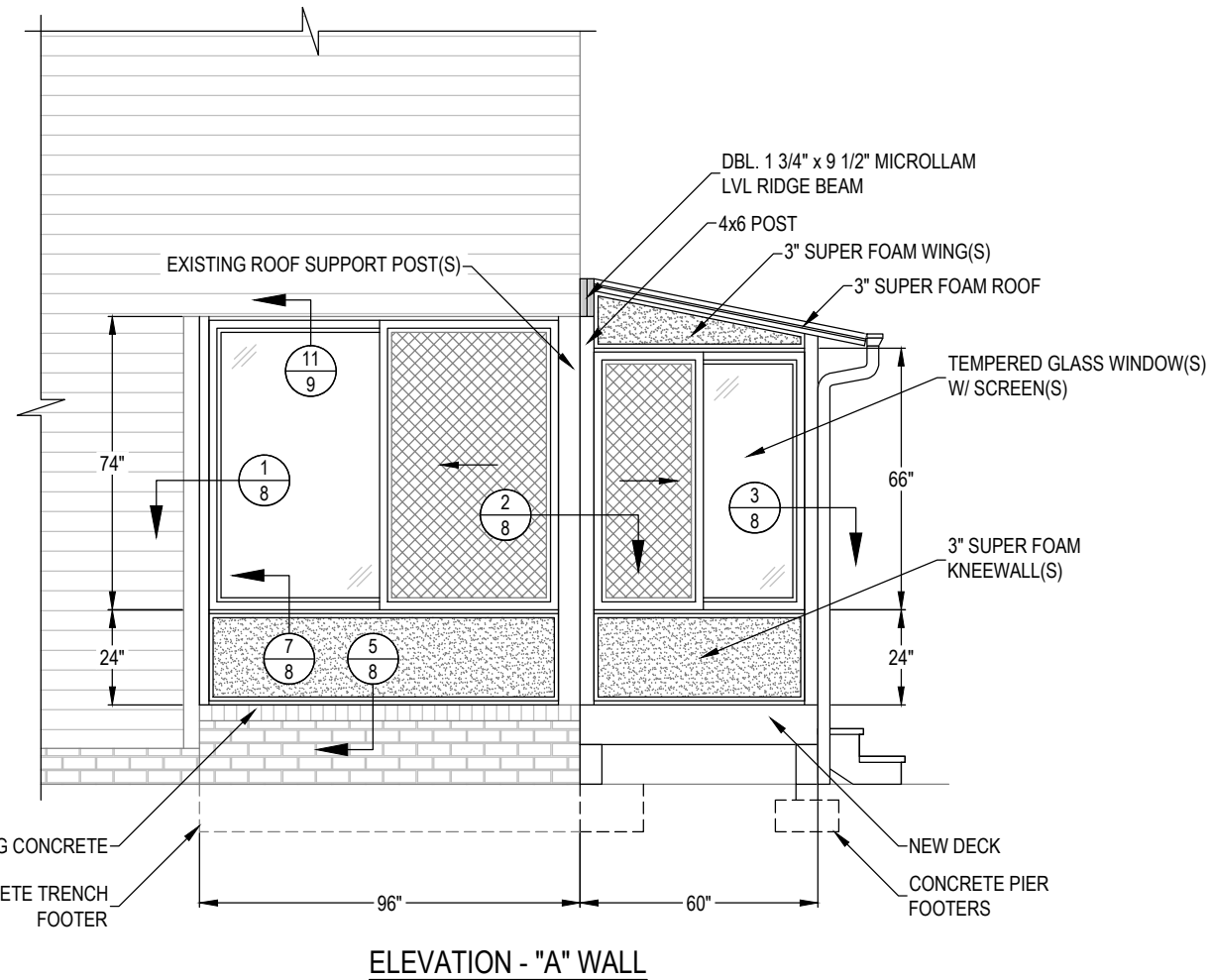

ERIC OETJEN, P.E., M. ENG.  
NC. PROFESSIONAL ENGINEER (NC. LIC. #049195)  
5 GREENE STREET  
FORT THOMAS, KY. 41075  
PH. # 859-393-9049



LOCATION  
 GDI - RALEIGH  
 951 AVIATION PKWY, SUITE 1000  
 MORRISVILLE, NC 27560  
 984-212-8850

CHRISTINA GARCIA  
 300 CRESTHAVEN DRIVE  
 SANFORD, NC 27332  
 JOB #20445

DATE	12/20/21
DRAWN	MTS
SCALE	AS NOTED
SHEET	4 OF 9

DATE 12/20/21

DRAWN MTS  
 SCALE AS NOTED  
 SHEET 4 OF 9

THIS DRAWING IS PROPERTY OF GREAT DAY IMPROVEMENTS, LLC., AND DUPLICATION OF THIS DRAWING WITHOUT OUR EXPRESSED WRITTEN CONSENT IS PROHIBITED. ALL RIGHTS RESERVED.

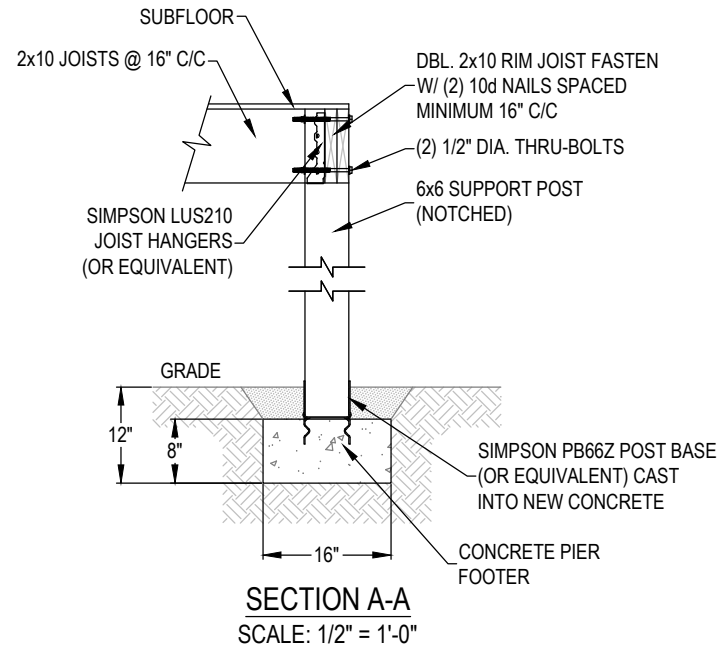

SECTION A-A  
 SCALE: 1/2" = 1'-0"

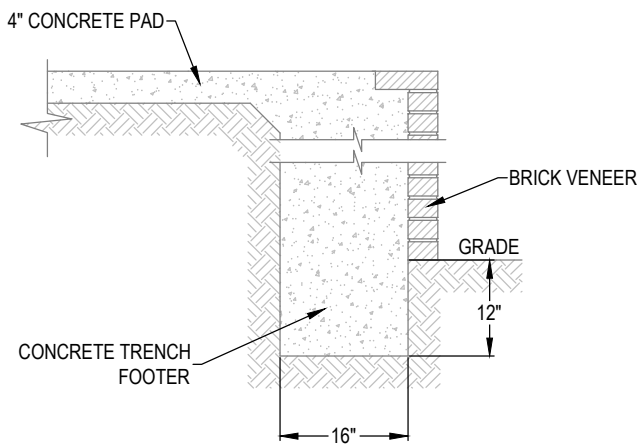

SECTION B-B  
 SCALE: 1/2" = 1'-0"

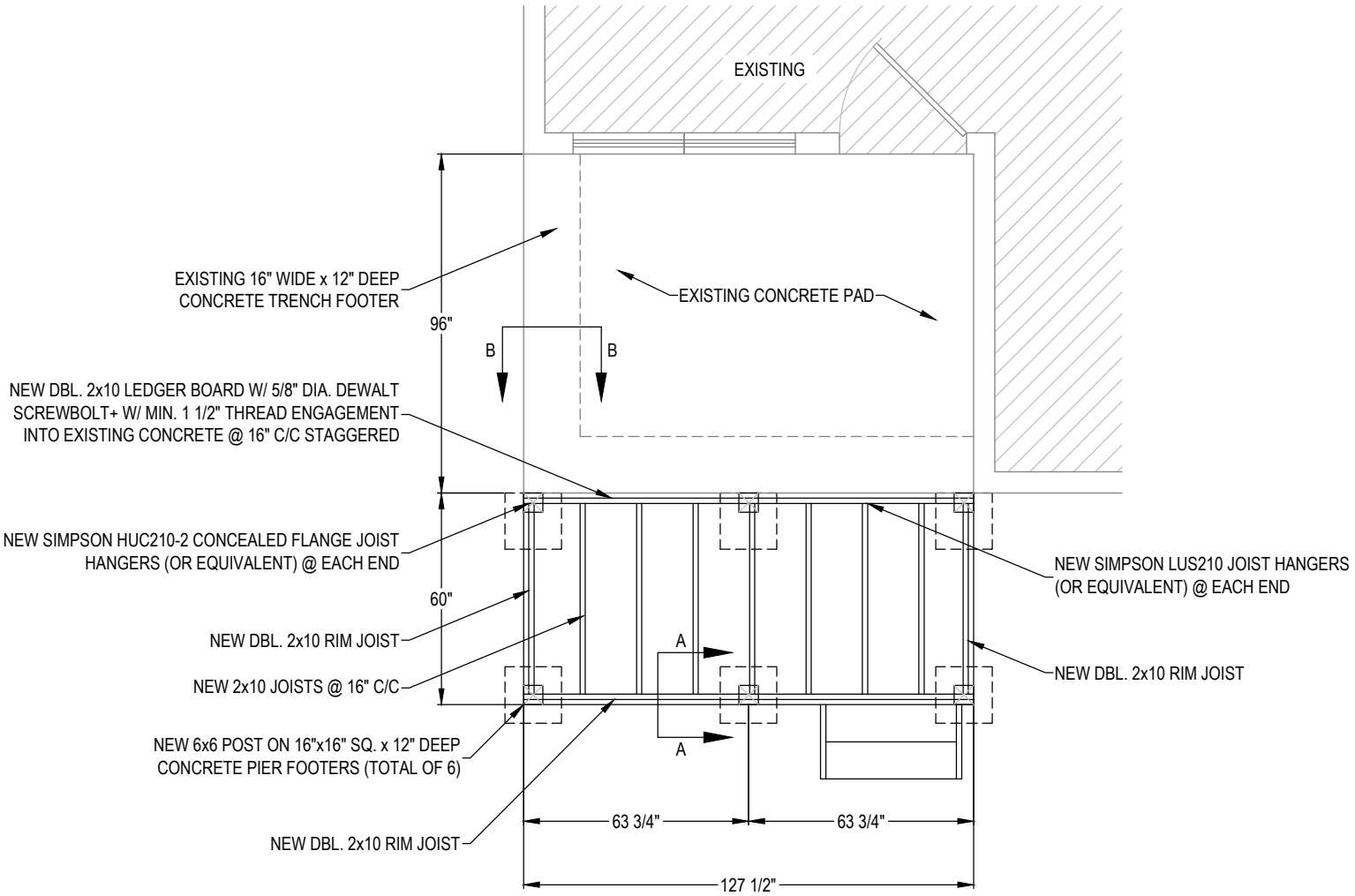

FOUNDATION PLAN  
 SCALE: 1/4" = 1'-0"

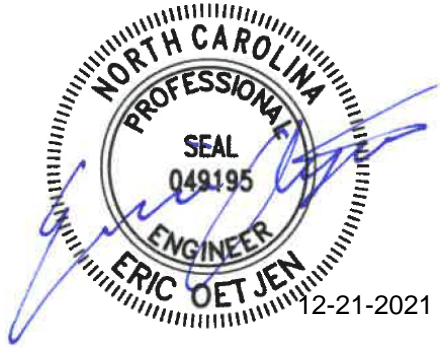

- NOTES:  
 1. DECK TO BE BUILT PER 2018 NC RESIDENTIAL CODE  
 2. ALL DECK LUMBER IS PRESSURE TREATED SOUTHERN YELLOW PINE

ERIC OETJEN, P.E., M. ENG.  
 NC. PROFESSIONAL ENGINEER (NC. LIC. #049195)  
 5 GREENE STREET  
 FORT THOMAS, KY. 41075  
 PH. # 859-393-9049



LOCATION  
 GDI - RALEIGH  
 951 AVIATION PKWY, SUITE 1000  
 MORRISVILLE, NC 27560  
 984-212-8850

CHRISTINA GARCIA  
 300 CRESTHAVEN DRIVE  
 SANFORD, NC 27332  
 JOB #20445



DATE  
 12/20/21

DRAWN  
 MTS

SCALE  
 1/4" = 1'-0"

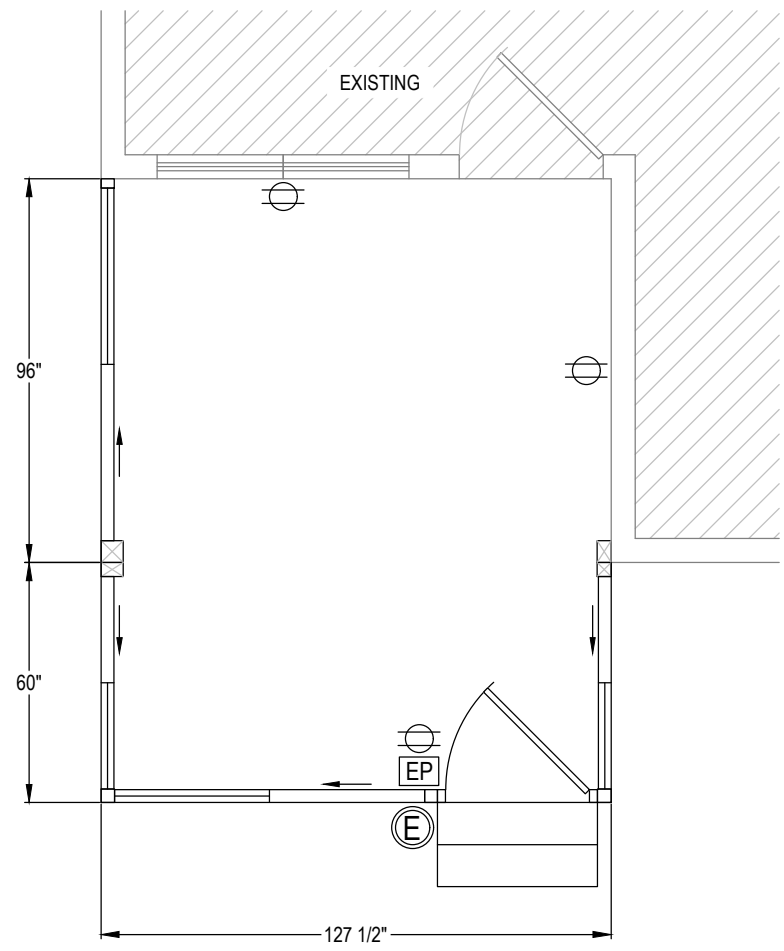

SHEET  
 5 OF 9

ERIC OETJEN, P.E., M. ENG.  
 NC. PROFESSIONAL ENGINEER (NC. LIC. #049195)  
 5 GREENE STREET  
 FORT THOMAS, KY. 41075  
 PH. # 859-393-9049



ELECTRICAL PLAN

GDI ELECTRICAL SYMBOL LEGEND

-  ELECTRICAL RACEWAY POST
-  DUPLEX RECEPTACLE
-  EXIT LIGHT

THIS DRAWING IS PROPERTY OF GREAT DAY IMPROVEMENTS, LLC., AND DUPLICATION OF THIS DRAWING WITHOUT OUR EXPRESSED WRITTEN CONSENT IS PROHIBITED. ALL RIGHTS RESERVED.

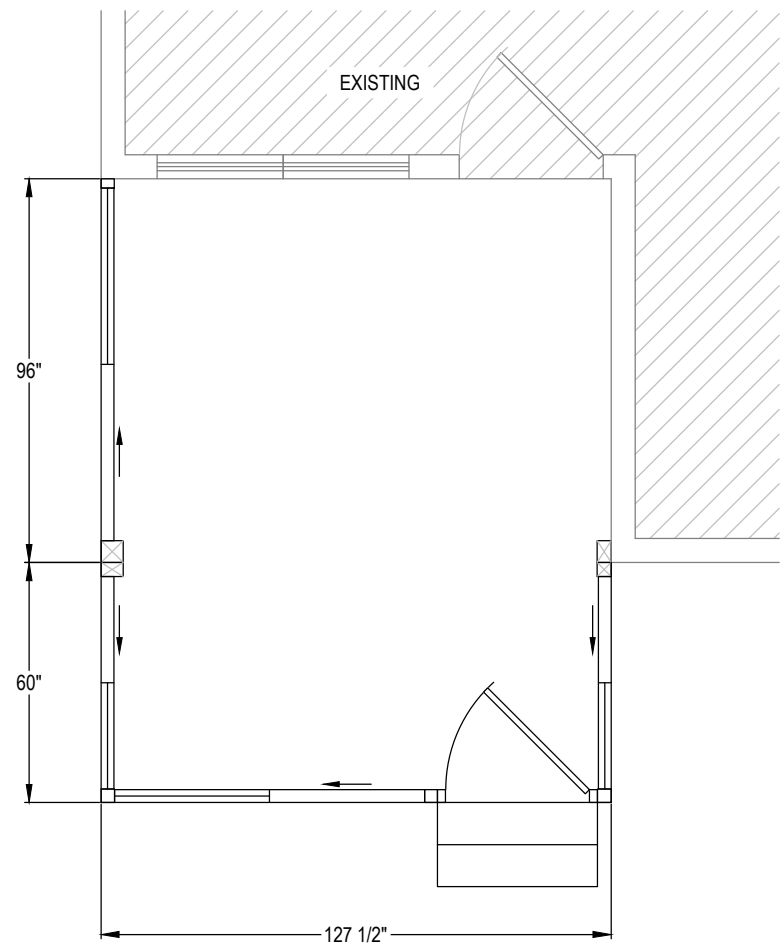

FLOOR PLAN

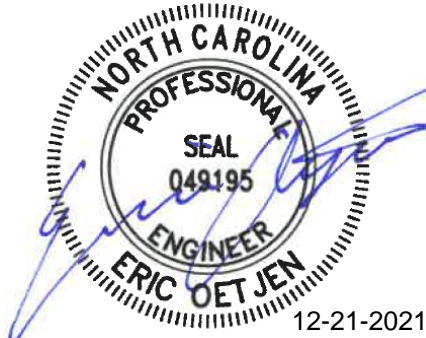

ERIC OETJEN, P.E., M. ENG.  
 NC. PROFESSIONAL ENGINEER (NC. LIC. #049195)  
 5 GREENE STREET  
 FORT THOMAS, KY. 41075  
 PH. # 859-393-9049



LOCATION  
 GDI - RALEIGH  
 951 AVIATION PKWY, SUITE 1000  
 MORRISVILLE, NC 27560  
 984-212-8850

CHRISTINA GARCIA  
 300 CRESTHAVEN DRIVE  
 SANFORD, NC 27332  
 JOB #20445

--	--	--	--

DATE  
 12/20/21

DRAWN  
 MTS

SCALE  
 1/4" = 1'-0"

SHEET  
 6 OF 9

THIS DRAWING IS PROPERTY OF GREAT DAY IMPROVEMENTS, LLC., AND DUPLICATION OF THIS DRAWING WITHOUT OUR EXPRESSED WRITTEN CONSENT IS PROHIBITED. ALL RIGHTS RESERVED



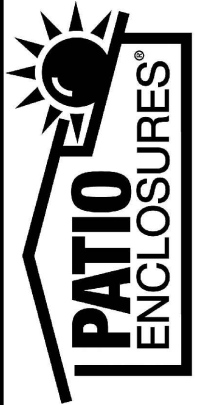

BY GREAT DAY IMPROVEMENTS, LLC

LOCATION

GDI - RALEIGH  
951 AVIATION PKWY, SUITE 1000  
MORRISVILLE, NC 27560  
984-212-8850

CHRISTINA GARCIA  
300 CRESTHAVEN DRIVE  
SANFORD, NC 27332  
JOB #20445

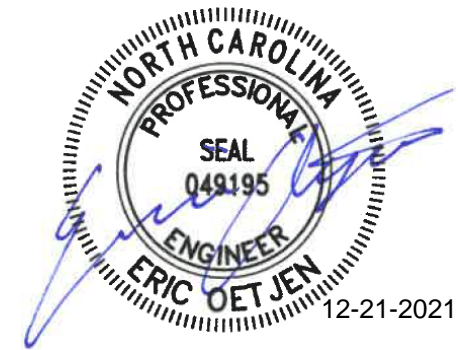

DATE  
12/20/21

DRAWN  
MTS

SCALE  
1/4" = 1'-0"

SHEET  
7 OF 9

ERIC OETJEN, P.E., M. ENG.  
NC. PROFESSIONAL ENGINEER (NC. LIC. #049195)  
5 GREENE STREET  
FORT THOMAS, KY. 41075  
PH. # 859-393-9049

THIS DRAWING IS PROPERTY OF GREAT DAY IMPROVEMENTS, LLC., AND DUPLICATION OF THIS DRAWING WITHOUT OUR EXPRESSED WRITTEN CONSENT IS PROHIBITED. ALL RIGHTS RESERVED.

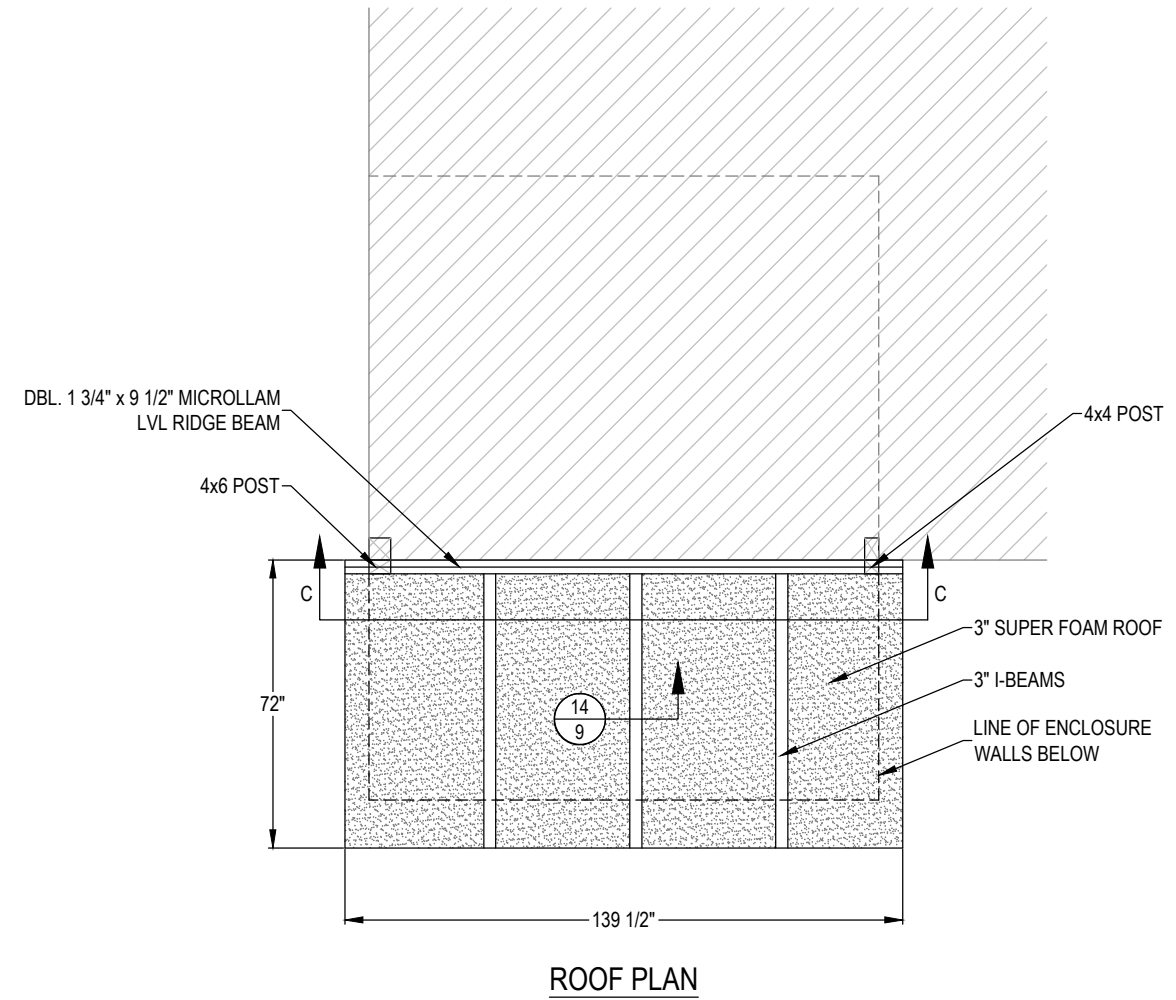
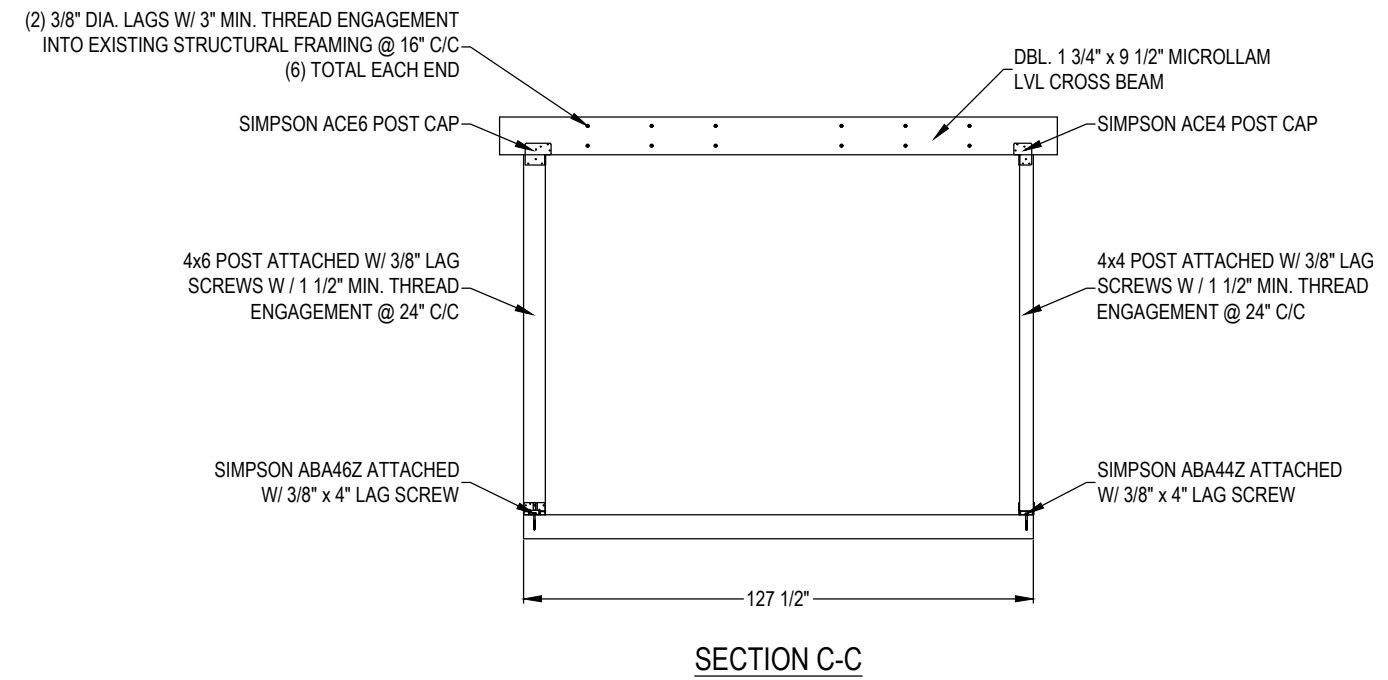

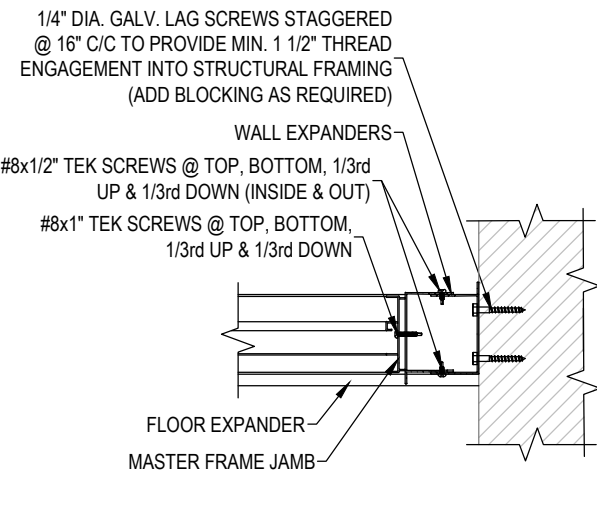

1 PLAN VIEW OF MASTER FRAME JAMB & DBL. EXPANDER CONNECTION @ EXISTING WALL

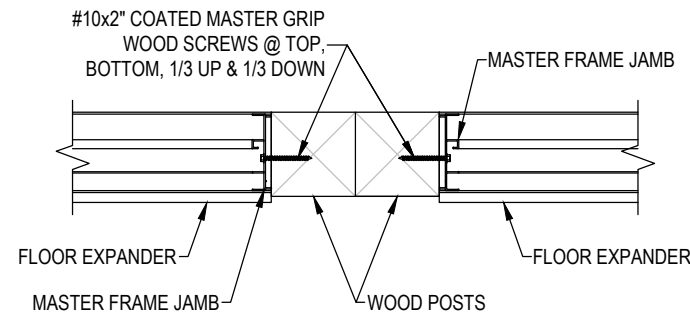

2 PLAN VIEW OF MASTER FRAME JAMBS CONNECTION @ WOOD POSTS

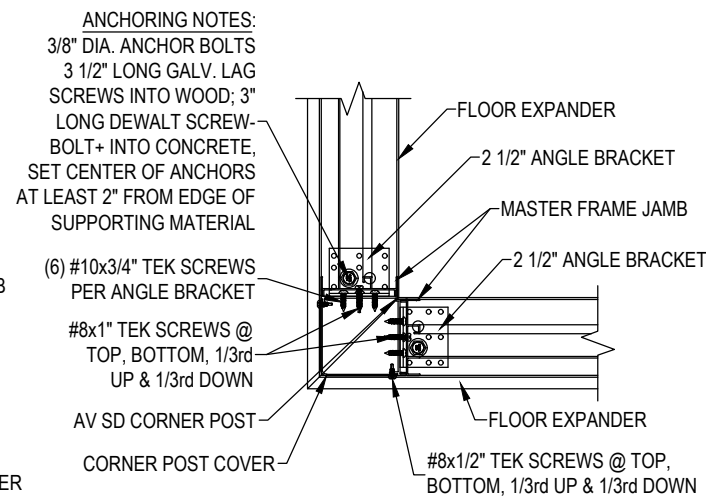

3 PLAN VIEW OF MASTER FRAME JAMBS CONNECTION @ CORNER POST

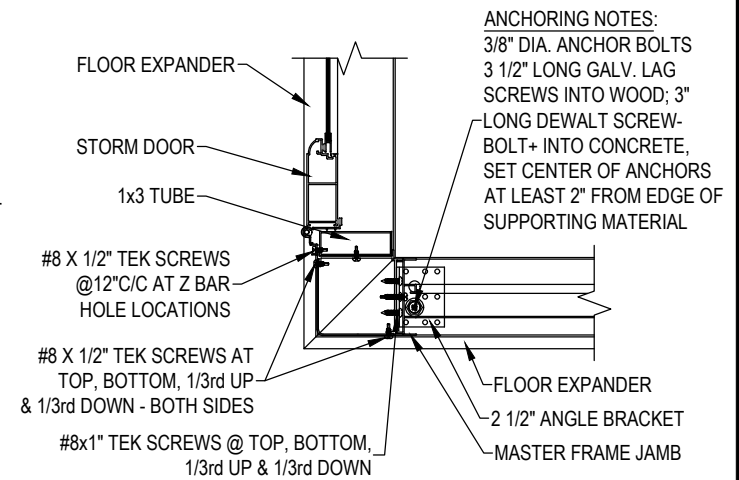

4 PLAN VIEW OF MASTER FRAME & STORM DOOR JAMBS CONNECTION @ CORNER POST

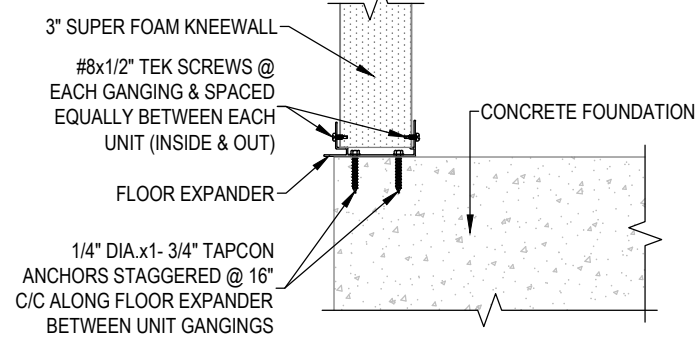

5 SECTION THROUGH FOAM KNEEWALL CONNECTION @ CONCRETE FOUNDATION

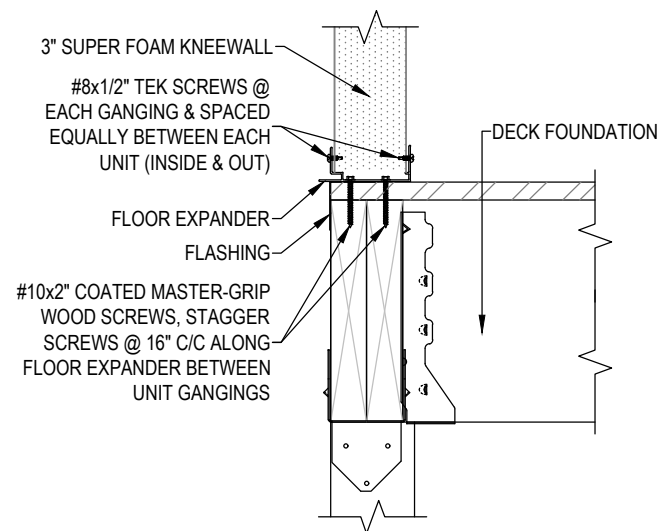

6 SECTION THROUGH FOAM KNEEWALL CONNECTION @ DECK FOUNDATION

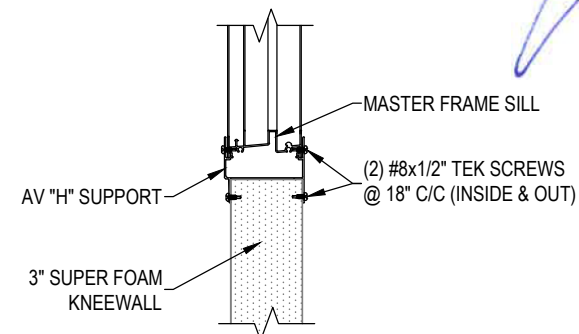

7 SECTION THROUGH MASTER FRAME SILL CONNECTION @ FOAM KNEEWALL



LOCATION  
GDI - RALEIGH  
951 AVIATION PKWY, SUITE 1000  
MORRISVILLE, NC 27560  
984-212-8850

CHRISTINA GARCIA  
300 CRESTHAVEN DRIVE  
SANFORD, NC 27332  
JOB #20445

--	--	--	--

DATE  
12/20/21

ERIC OETJEN, P.E., M. ENG.  
NC. PROFESSIONAL ENGINEER (NC. LIC. #049195)  
5 GREENE STREET  
FORT THOMAS, KY. 41075  
PH. # 859-393-9049

DRAWN  
MTS

SCALE  
1 1/2" = 1'-0"

SHEET  
8 OF 9

THIS DRAWING IS PROPERTY OF GREAT DAY IMPROVEMENTS, LLC., AND DUPLICATION OF THIS DRAWING WITHOUT OUR EXPRESSED WRITTEN CONSENT IS PROHIBITED. ALL RIGHTS RESERVED.



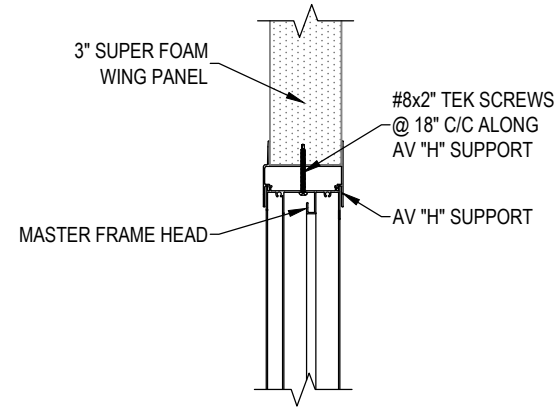

8 SECTION THROUGH MASTER FRAME HEAD CONNECTION @ FOAM WING

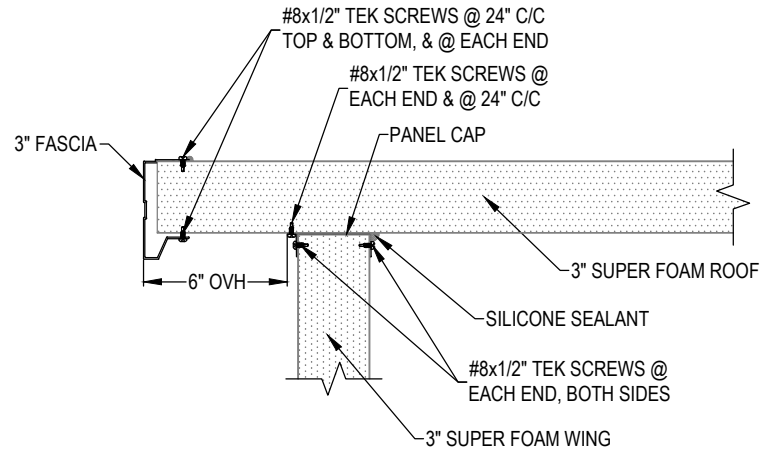

9 SECTION THROUGH 3" SUPER FOAM ROOF PANEL CONNECTION @ 3" SUPER FOAM WING PANEL

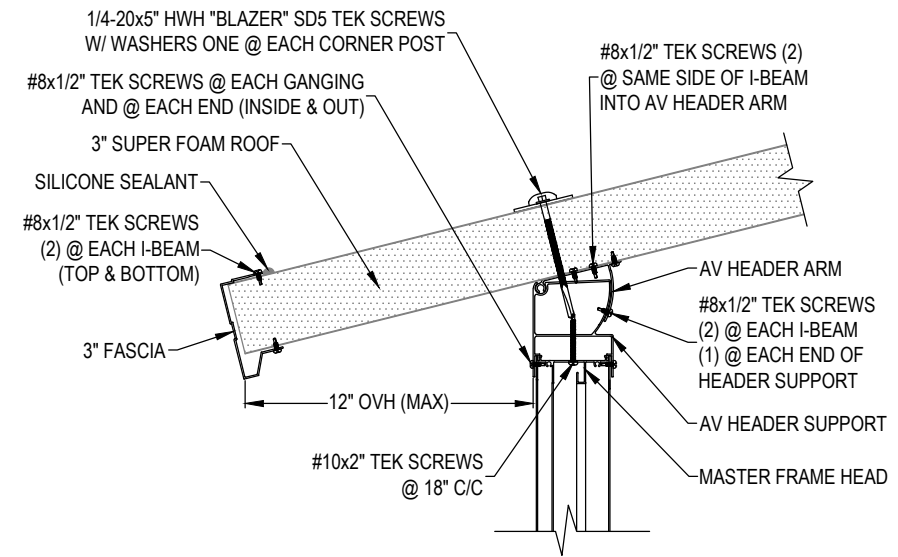

10 SECTION THROUGH MASTER FRAME & HEADER CONNECTION @ 3" SUPER FOAM ROOF

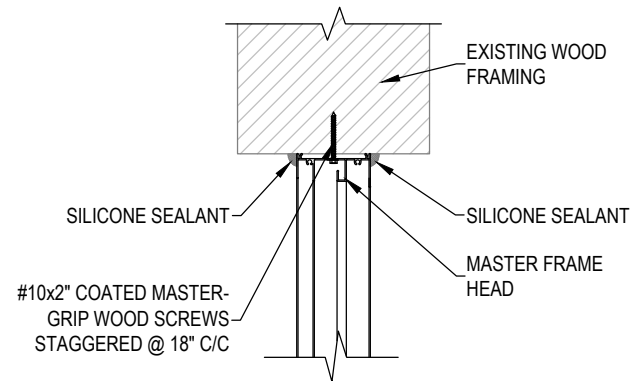

11 SECTION THROUGH MASTER FRAME HEAD CONNECTION @ EXISTING HEADER

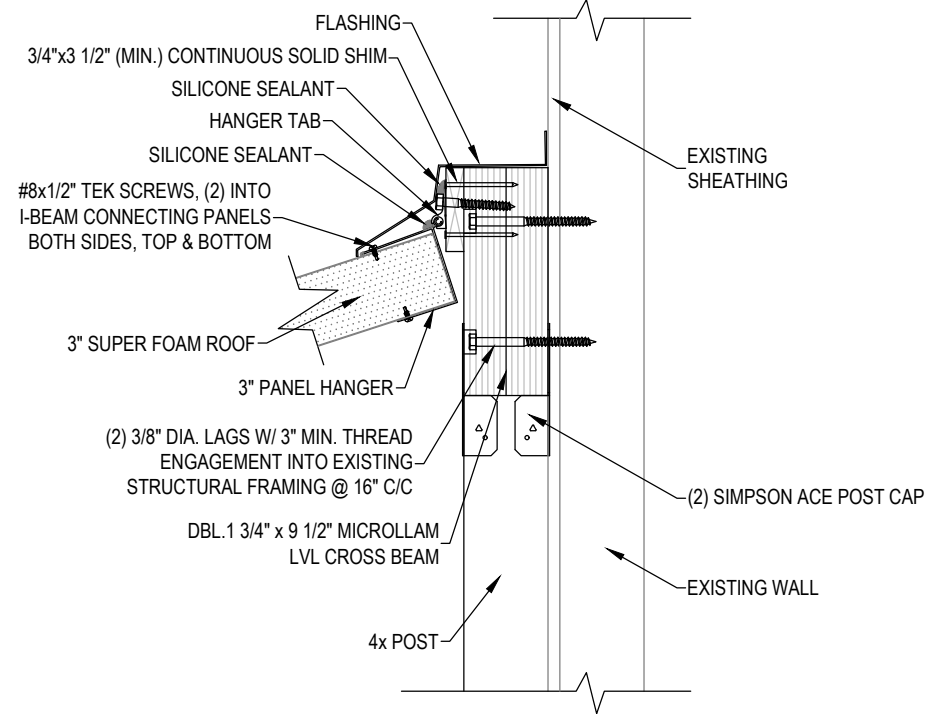

13 SECTION THROUGH 3" SUPER FOAM ROOF & PANEL HANGER ASSEMBLY CONNECTION @ EXISTING WALL

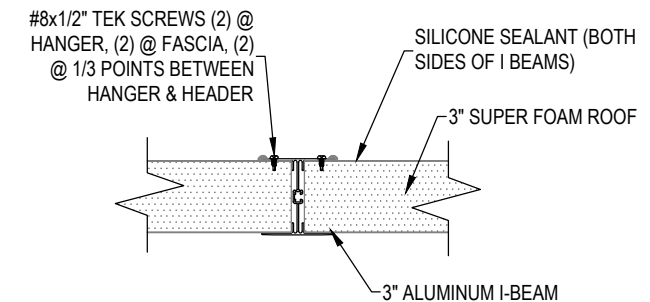

14 SECTION THROUGH 3" ROOF CONNECTION @ I-BEAM

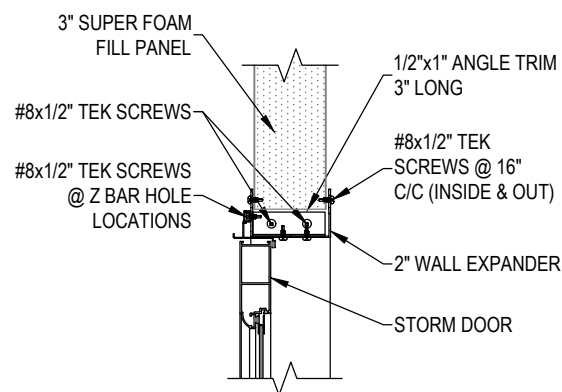

12 SECTION THROUGH STORM DOOR CONNECTION @ FOAM FILL PANEL

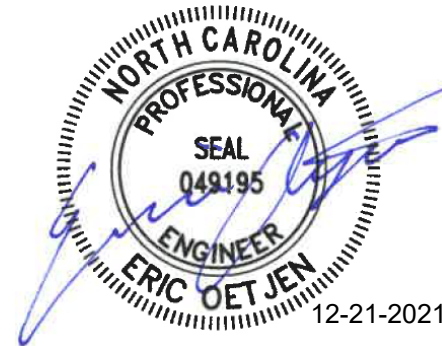

ERIC OETJEN, P.E., M. ENG.  
 NC. PROFESSIONAL ENGINEER (NC. LIC. #049195)  
 5 GREENE STREET  
 FORT THOMAS, KY. 41075  
 PH. # 859-393-9049

LOCATION  
 GDI - RALEIGH  
 951 AVIATION PKWY, SUITE 1000  
 MORRISVILLE, NC 27560  
 984-212-8850

CHRISTINA GARCIA  
 300 CRESTHAVEN DRIVE  
 SANFORD, NC 27332  
 JOB #20445

--	--	--	--

DATE	12/20/21
DRAWN	MTS
SCALE	1 1/2" = 1'-0"
SHEET	9 OF 9

THIS DRAWING IS PROPERTY OF GREAT DAY IMPROVEMENTS, LLC., AND DUPLICATION OF THIS DRAWING WITHOUT OUR EXPRESSED WRITTEN CONSENT IS PROHIBITED. ALL RIGHTS RESERVED.