

Longh.

Longh.

Longh.



STRUCTURAL DESIGN

ENCLOSED BUILDING

**MAXIMUM 30'-0" WIDE X 16'-0" EAVE HEIGHT-
BOX EAVE FRAME AND BOW FRAME**

6 January 2021

Revision 0

M&A Project No. 20310S

Prepared for:

Longhorn Steel Structures, Inc.
272 Hickory Street
Mount Airy, NC 27030

Prepared by:

Moore and Associates Engineering and Consulting, Inc.
1009 East Avenue
North Augusta, SC 29841

401 S. Main Street, Suite 200
Mount Airy, NC 27030



**MOORE AND ASSOCIATES
ENGINEERING AND CONSULTING**

Longhorn Steel Structures

Longhorn Steel Structures

Longhorn Steel Structures

Longhorn Steel Structures







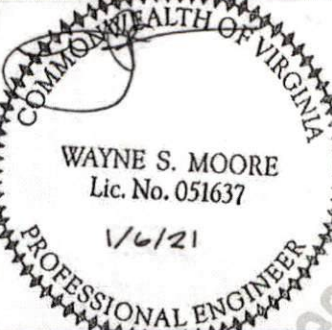

Longhorn Steel Structures

Longhorn Steel Structures

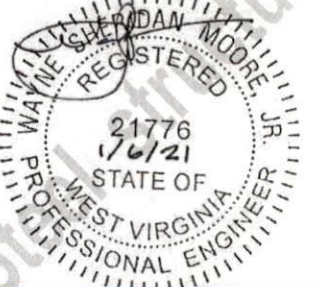
Longhorn

Longhorn

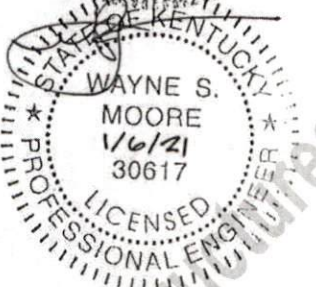
Longhorn

MOORE AND ASSOCIATES
ENGINEERING AND CONSULTING, INC.

DRAWN BY: JG
CHECKED BY: PDH
PROJECT MGR: WSM
CLIENT: LONGHORN

LONGHORN STEEL STRUCTURES, INC.
272 HICKORY STREET
MOUNT AIRY, NC 27030
30'-0" x 16'-0" ENCLOSED STRUCTURE

DATE: 1-6-21
SCALE: NTS
SHT. 1
JOB NO: 20310S
FIG. NO: SK-3
REV: 0

THIS DOCUMENT IS THE PROPERTY OF MOORE AND ASSOCIATES ENGINEERING AND CONSULTING, INC. THE UNAUTHORIZED REPRODUCTION, COPYING, OR OTHERWISE USE OF THIS DOCUMENT IS STRICTLY PROHIBITED AND ANY INFRINGEMENT THEREOF MAY BE SUBJECT TO LEGAL ACTION.

Longhorn

Longhorn

Longhorn

Longh.

Longh.

Longh.

DRAWING INDEX

SHEET 1	PE SEAL COVER SHEET
SHEET 2	DRAWING INDEX
SHEET 3	INSTALLATION NOTES AND SPECIFICATIONS
SHEET 4	TYPICAL SIDE AND END ELEVATIONS
SHEET 5	TYPICAL RAFTER/COLUMN FRAME AND SIDE FRAMING SECTION (BOX EAVE RAFTER)
SHEET 6	COLUMN CONNECTION DETAILS (BOX EAVE RAFTER)
SHEET 7	TYPICAL RAFTER/COLUMN FRAME AND SIDE FRAMING SECTION (BOW EAVE RAFTER)
SHEET 8	COLUMN CONNECTION DETAILS (BOW EAVE RAFTER)
SHEET 9	BASE RAIL ANCHORAGE OPTIONS
SHEET 9A	BASE RAIL ANCHORAGE OPTION
SHEET 10	TYPICAL END WALL AND SIDE WALL FRAMING SECTIONS (BOX EAVE RAFTER)
SHEET 11	TYPICAL END WALL AND SIDE WALL FRAMING SECTIONS (BOW EAVE RAFTER)
SHEET 12	CONNECTION DETAILS
SHEET 13	CONNECTION DETAILS
SHEET 14	LEAN-TO OPTIONS (BOX EAVE RAFTER)
SHEET 15	LEAN-TO OPTIONS (BOW EAVE RAFTER)
SHEET 16	VERTICAL ROOF/SIDING OPTION END AND SIDE ELEVATION AND SECTION (BOX EAVE RAFTER)

Longhorn Steel Structures

Longhorn Steel Structures

Longhorn Steel Structures

Longhorn Steel Structures

Longhorn Steel Structures

Longhorn Steel Structures

Longhorn Steel Structures

Longhorn Steel Structures

Longhorn Steel Structures

Longhorn Steel Structures

Longhorn Steel Structures

MOORE AND ASSOCIATES ENGINEERING AND CONSULTING, INC.	DRAWN BY: JG	LONGHORN STEEL STRUCTURES, INC. 272 HICKORY STREET MOUNT AIRY, NC 27030		
	CHECKED BY: PDH	30'-0" x 16'-0" ENCLOSED STRUCTURE		
THIS DOCUMENT IS THE PROPERTY OF MOORE AND ASSOCIATES ENGINEERING AND CONSULTING. THE UNAUTHORIZED REPRODUCTION, COPYING, OR OTHERWISE USE OF THIS DOCUMENT IS STRICTLY PROHIBITED AND ANY INFRINGEMENT THEREON MAY BE SUBJECT TO LEGAL ACTION.	PROJECT MGR: WSM	DATE: 1-6-21	SCALE: NTS	JOB NO: 20310S
	CLIENT: LONGHORN	SHT. 2	DWG. NO: SK-3	REV: 0

INSTALLATION NOTES AND SPECIFICATIONS

1. DESIGN IS FOR MAXIMUM 30'-0" WIDE x 16'-0" EAVE HEIGHT ENCLOSED STRUCTURES.
2. DESIGN WAS DONE IN ACCORDANCE WITH THE 2020 FLORIDA BUILDING CODE (FBC), 7TH EDITION, 2018 NORTH CAROLINA BUILDING CODE, 2018 INTERNATIONAL BUILDING CODE (IBC), AND 2015 IBC.
3. DESIGN LOADS ARE AS FOLLOWS:
 - A) DEAD LOAD = 1.5 PSF
 - B) LIVE LOAD = 12 PSF
 - C) GROUND SNOW LOAD = 30 PSF

NOTE: UNBALANCED SNOW LOAD DUE TO DRIFTING HAS NOT BEEN EVALUATED.
4. 3-SECOND GUST ULTIMATE WIND SPEED (V_{ULT}) = \leq 145 MPH (NOMINAL WIND SPEED = \leq 112 MPH).
5. MAXIMUM RAFTER/COLUMN AND END COLUMN SPACING = 5.0 FEET (UNLESS NOTED OTHERWISE).
6. ENDWALL COLUMNS (POSTS) AND SIDE WALL COLUMNS ARE EQUIVALENT IN SIZE AND SPACING (UNLESS NOTED OTHERWISE).
7. RISK CATEGORY I.
8. WIND EXPOSURE CATEGORY B.
9. SPECIFICATIONS APPLICABLE TO 29 GAUGE METAL PANELS FASTENED DIRECTLY TO 2 1/2" x 2 1/2" - 14 GAUGE TUBE STEEL (TS) FRAMING MEMBERS (UNLESS NOTED OTHERWISE). 2 1/4" x 2 1/4" - 12 GAUGE TS MAY BE USED AS OPTIONAL FRAMING MEMBERS.
10. AVERAGE FASTENER SPACING ON-CENTERS ALONG RAFTERS OR HAT CHANNELS, AND COLUMNS (INTERIOR OR END) = 10 INCHES.
11. FASTENERS CONSIST OF #12-14x3/4" SELF-DRILLING FASTENER (SDF), USE CONTROL SEAL WASHER WITH EXTERIOR FASTENERS. SPECIFICATIONS APPLICABLE ONLY FOR MEAN ROOF HEIGHT OF 16 FEET OR LESS, AND ROOF SLOPES OF 14" (3:12 PITCH) OR LESS SPACING REQUIREMENTS FOR OTHER ROOF HEIGHTS AND/OR SLOPES MAY VARY. ROOF SLOPES LESS THAN 3:12 REQUIRE USE OF JOINT SEALANT.
12. ANCHORS SHALL BE INSTALLED THROUGH BASE RAIL WITHIN 6" OF EACH COLUMN.
13. STANDARD GROUND ANCHORS (SOIL NAILS) CONSIST OF #4 REBAR W/ WELDED TAIL x 30" LONG AND MAY ONLY BE USED IN CONJUNCTION WITH OTHER (OPTIONAL) ANCHOR DEVICES AND ONLY IN SUITABLE SOILS. OPTIONAL ANCHORAGE MAY BE USED IN SUITABLE SOILS. MUST BE USED IN UNSUITABLE SOILS AS NOTED. COORDINATE WITH LOCAL CODES/ORDINANCES REGARDING MINIMUM LENGTH FOR FOOT DEPTH PROTECTION.
14. WIND FORCES GOVERN OVER SEISMIC FORCES. SEISMIC PARAMETERS ANALYZED ARE:
 - SOIL SITE CLASS = D
 - RISK CATEGORY I
 - $R = 1.25$
 - $I_E = 1.0$
 - $S = 2.039 g$
 - $V = C_S W$
 - $g_{M1} = 1.258 g$

MOORE AND ASSOCIATES
ENGINEERING AND CONSULTING, INC.

DRAWN BY: JG

CHECKED BY: PDH

PROJECT MGR: VSM

CLIENT: LONGHORN

LONGHORN STEEL STRUCTURES, INC.
272 HICKORY STREET
MOUNT AIRY, NC 27030
30'-0" x 16'-0" ENCLOSED STRUCTURE

DATE: 1-6-21

SHT. 3

SCALE: NTS

FIG. NO: SK-3

JOB NO: 20310S

REV: 0

THIS DOCUMENT IS THE PROPERTY OF MOORE AND ASSOCIATES ENGINEERING AND CONSULTING. THE UNAUTHORIZED REPRODUCTION, COPYING, OR OTHERWISE USE OF THIS DOCUMENT IS STRICTLY PROHIBITED AND ANY INFRINGEMENT THEREOF MAY BE SUBJECT TO LEGAL ACTION.

Longhorn Steel Structures

Longhorn Steel Structures

Longhorn Steel Structures

BOX EAVE FRAME RAFTER STRUCTURE

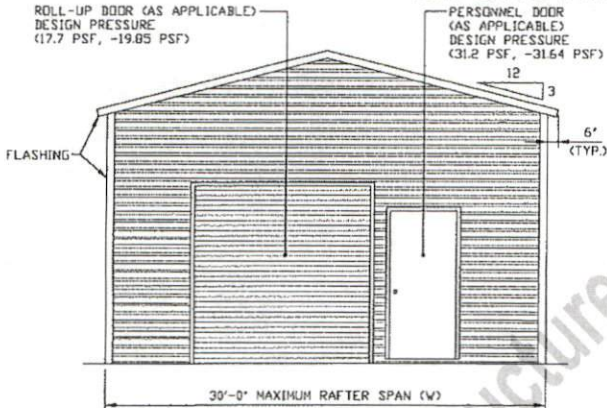

TYPICAL END ELEVATION
SCALE: NTS

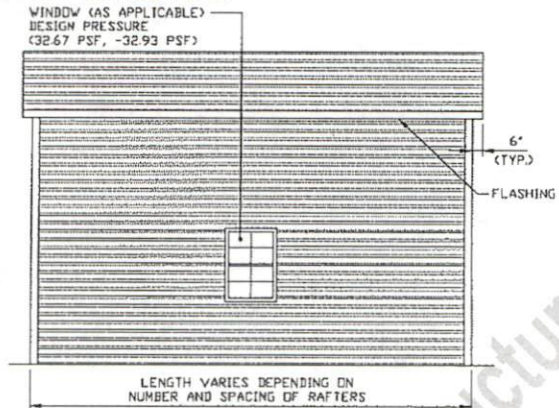

TYPICAL SIDE ELEVATION
SCALE: NTS

BOX EAVE FRAME RAFTER STRUCTURE

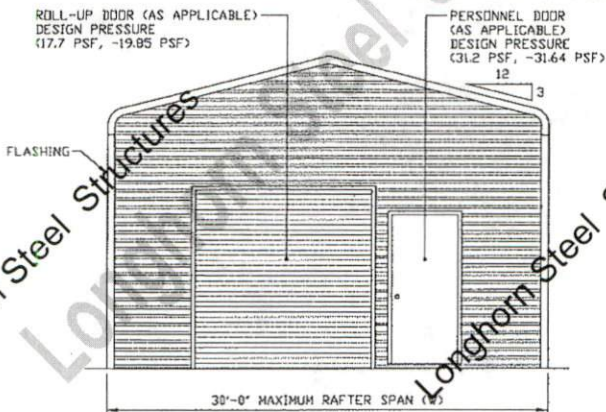

TYPICAL END ELEVATION
SCALE: NTS

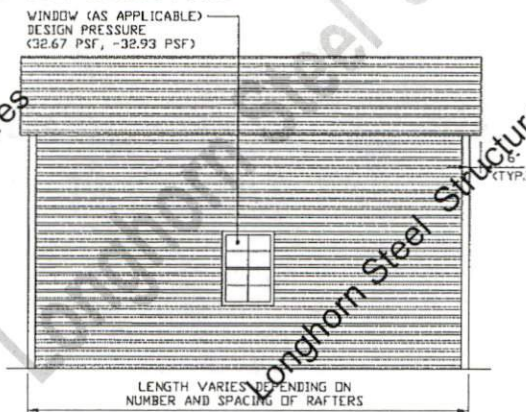

TYPICAL SIDE ELEVATION
SCALE: NTS

MOORE AND ASSOCIATES
ENGINEERING AND CONSULTING, INC.

DRAWN BY: JG
 CHECKED BY: PDH
 PROJECT MGR: WSM
 CLIENT: LONGHORN

LONGHORN STEEL STRUCTURES, INC.
 272 HICKORY STREET
 MOUNT AIRY, NC 27030
 30'-0" x 16'-0" ENCLOSED STRUCTURE

THIS DOCUMENT IS THE PROPERTY OF MOORE AND ASSOCIATES ENGINEERING AND CONSULTING, INC. UNAUTHORIZED REPRODUCTION, COPYING, OR OTHERWISE USE OF THIS DOCUMENT IS STRICTLY PROHIBITED AND ANY INFRINGEMENT THEREOF MAY BE SUBJECT TO LEGAL ACTION.

DATE: 1-6-21
 SCALE: NTS
 JOB NO: 20310S
 SHT. 4
 DWG. NO: SK-3
 REV: 0

Longhorn Steel Structures

Longhorn Steel Structures

Longhorn Steel Structures

Longi.

Longi.

Longi.

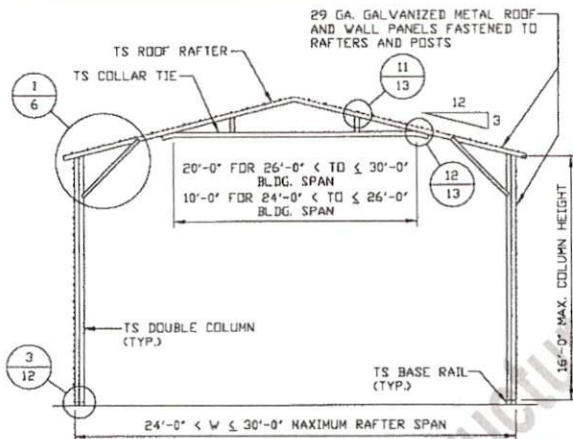

TYPICAL RAFTER/COLUMN FRAME SECTION
SCALE: NTS

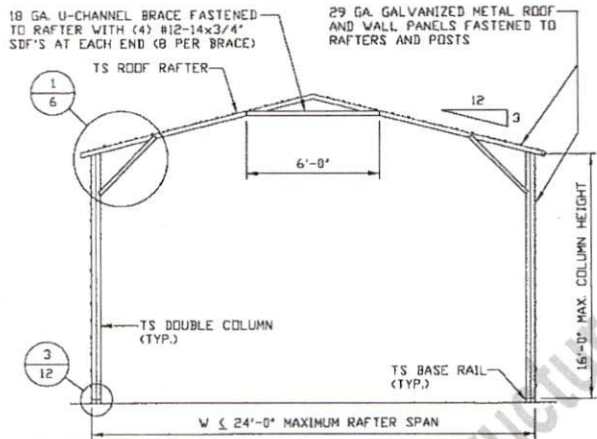

TYPICAL RAFTER/COLUMN FRAME SECTION
SCALE: NTS

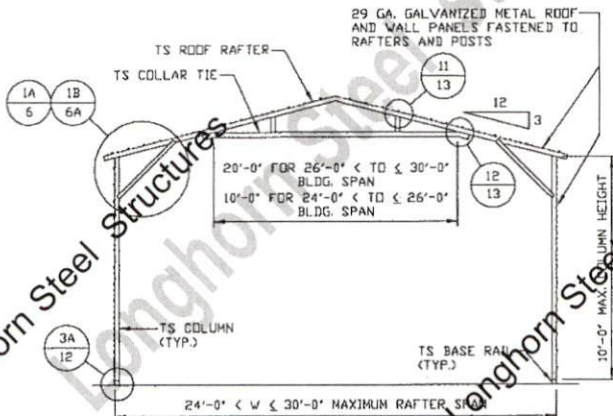

TYPICAL RAFTER/COLUMN FRAME SECTION
SCALE: NTS

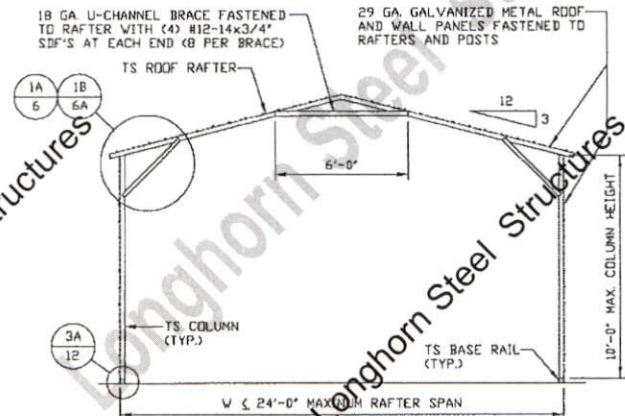

TYPICAL RAFTER/COLUMN FRAME SECTION
SCALE: NTS

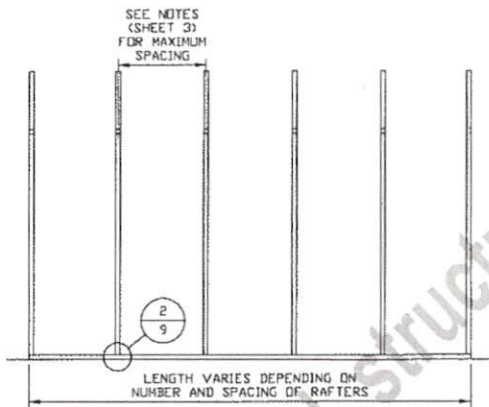

TYPICAL RAFTER/COLUMN SIDE FRAMING SECTION
SCALE: NTS

MOORE AND ASSOCIATES
ENGINEERING AND CONSULTING, INC.

DRAWN BY: JG

CHECKED BY: PDH

PROJECT MGR: WSM

CLIENT: LONGHORN

LONGHORN STEEL STRUCTURES, INC.
272 HICKORY STREET
MOUNT AIRY, NC 27030
30'-0" x 16'-0" ENCLOSED STRUCTURE

DATE: 1-6-21

SCALE: NTS

JOB NO: 20310S

SHT. 5

DRG. NO: SK-3

REV: 0

THIS DOCUMENT IS THE PROPERTY OF MOORE AND ASSOCIATES ENGINEERING AND CONSULTING. THE UNAUTHORIZED REPRODUCTION, COPYING, OR OTHERWISE USE OF THIS DOCUMENT IS STRICTLY PROHIBITED AND ANY INFRINGEMENT THEREOF MAY BE SUBJECT TO LEGAL ACTION.

Longh.

Longh.

Longh.

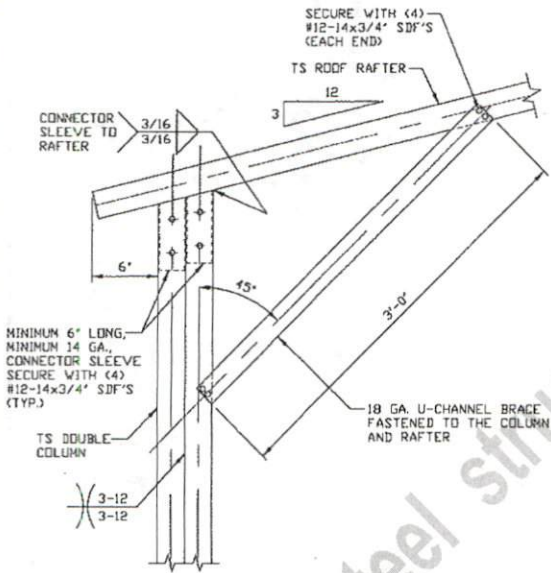

1 BOX EAVE RAFTER/CORNER POST CONNECTION DETAIL FOR HEIGHTS 10'-0" < TO ≤ 16'-0" SCALE: NTS

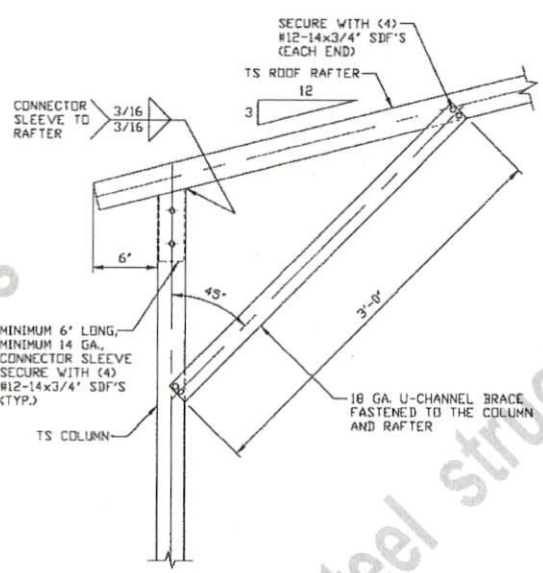

1A BOX EAVE RAFTER/CORNER POST CONNECTION DETAIL FOR HEIGHTS 8'-0" < TO ≤ 10'-0" SCALE: NTS

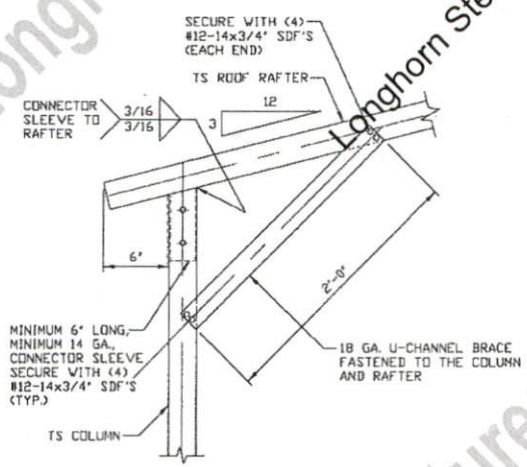

1B BOX EAVE RAFTER/CORNER POST CONNECTION DETAIL FOR HEIGHTS ≤ 8'-0" SCALE: NTS

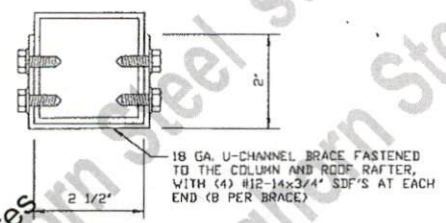

BRACE SECTION SCALE: NTS

MOORE AND ASSOCIATES ENGINEERING AND CONSULTING, INC.

DRAWN BY: JG
 CHECKED BY: PDH
 PROJECT MGR: WSM
 CLIENT: LONGHORN

LONGHORN STEEL STRUCTURES, INC.
 272 HICKORY STREET
 MOUNT AIRY, NC 27030
 30'-0" x 14'-0" ENCLOSED STRUCTURE

THIS DOCUMENT IS THE PROPERTY OF MOORE AND ASSOCIATES ENGINEERING AND CONSULTING, INC. THE UNAUTHORIZED REPRODUCTION, COPYING, OR OTHERWISE USE OF THIS DOCUMENT IS STRICTLY PROHIBITED AND ANY INFRINGEMENT THEREON MAY BE SUBJECT TO LEGAL ACTION.

DATE: 1-6-21
 SHT. 6
 SCALE: NTS
 B'G. NO: SK-3
 JOB NO: 20310S
 REV: 0

Longh.

Longh.

Longh.

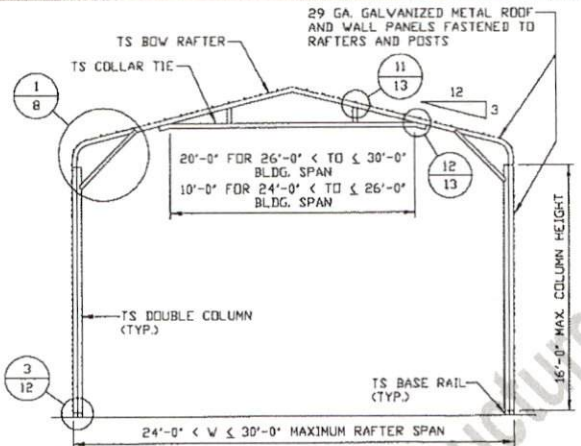

TYPICAL RAFTER/COLUMN FRAME SECTION
SCALE: NTS

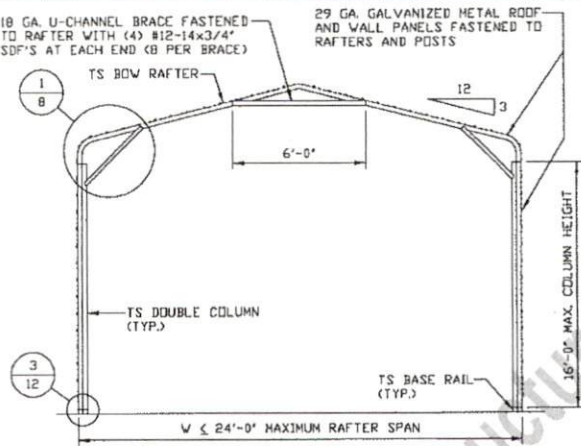

TYPICAL RAFTER/COLUMN FRAME SECTION
SCALE: NTS

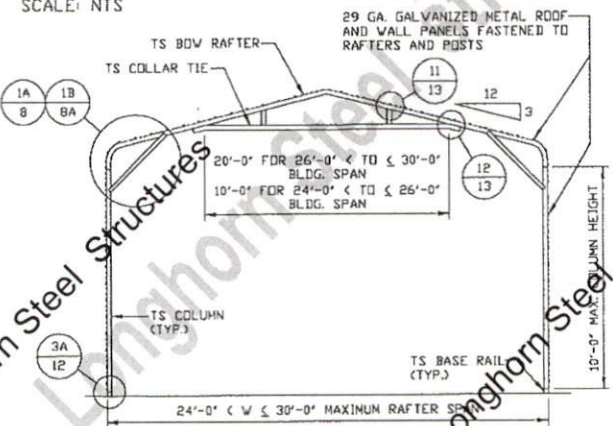

TYPICAL RAFTER/COLUMN FRAME SECTION
SCALE: NTS

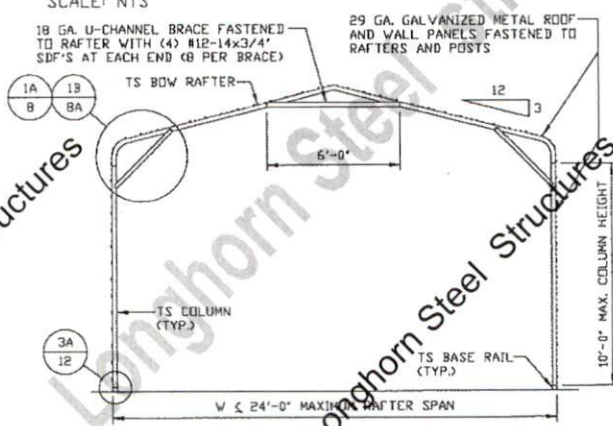

TYPICAL RAFTER/COLUMN FRAME SECTION
SCALE: NTS

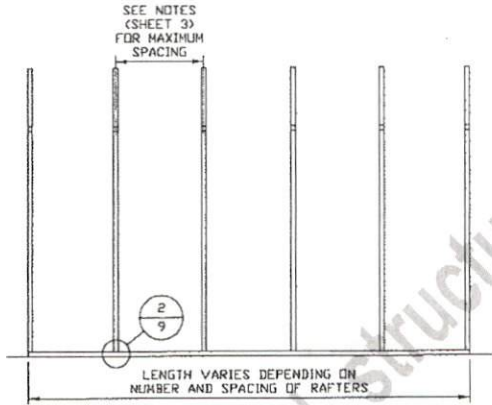

TYPICAL RAFTER/COLUMN SIDE FRAMING SECTION
SCALE: NTS

MOORE AND ASSOCIATES
ENGINEERING AND CONSULTING, INC.

DRAWN BY: JG
CHECKED BY: PDH
PROJECT MGR: WSM
CLIENT: LONGHORN

LONGHORN STEEL STRUCTURES, INC.
272 HICKORY STREET
MOUNT AIRY, NC 27030
30'-0" x 16'-0" ENCLOSED STRUCTURE

DATE: 1-6-21
SCALE: NTS
JOB NO: 20310S
BVG. NO: SK-3
REV: 0

THIS DOCUMENT IS THE PROPERTY OF MOORE AND ASSOCIATES ENGINEERING AND CONSULTING. THE UNAUTHORIZED REPRODUCTION, COPYING, OR OTHERWISE USE OF THIS DOCUMENT IS STRICTLY PROHIBITED AND ANY INFRINGEMENT THEREON MAY BE SUBJECT TO LEGAL ACTION.

Longh.

Longh.

Longh.

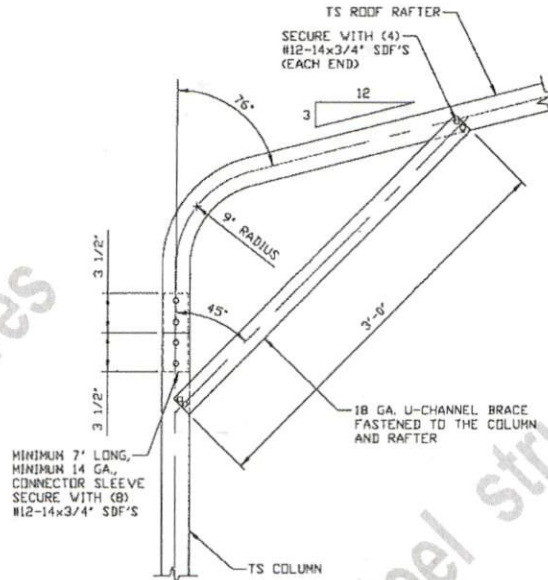
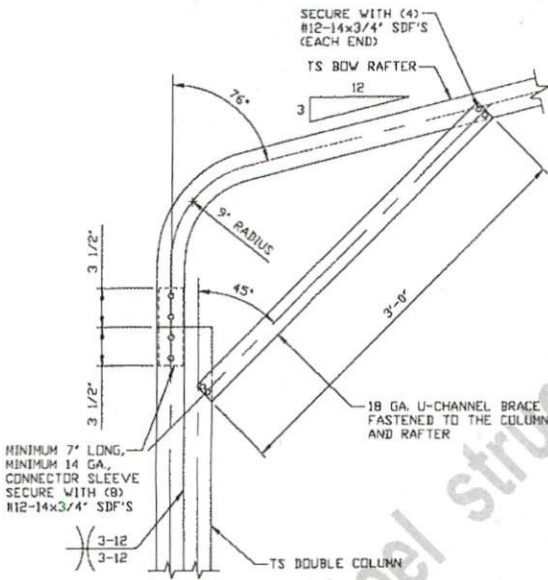

BOW EAVE RAFTER/CORNER POST CONNECTION DETAIL
FOR HEIGHTS 10'-0" < TO <= 16'-0"
 SCALE: NTS

BOW EAVE RAFTER/CORNER POST CONNECTION DETAIL
FOR HEIGHTS 8'-0" < TO <= 10'-0"
 SCALE: NTS

1

1A

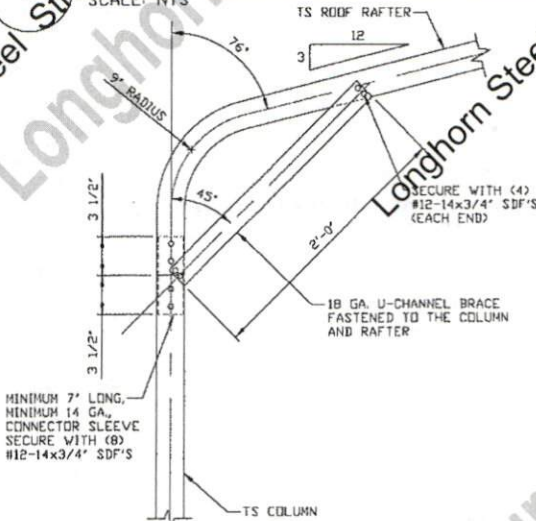

BOW EAVE RAFTER/CORNER POST CONNECTION DETAIL
FOR HEIGHTS <= 8'-0"
 SCALE: NTS

1B

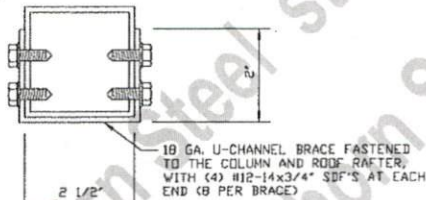

BRACE SECTION
 SCALE: NTS

MOORE AND ASSOCIATES
 ENGINEERING AND CONSULTING, INC.

DRAWN BY: JG

CHECKED BY: PDH

PROJECT MGR: WSM

CLIENT: LONGHORN

LONGHORN STEEL STRUCTURES, INC.
 272 HICKORY STREET
 MOUNT AIRY, NC 27030
 30'-0" x 16'-0" ENCLOSED STRUCTURE

DATE: 1-6-21

SCALE: NTS

JOB NO: 20310S

SHT. 8

DWG. NO: SK-3

REV: 0

THIS DOCUMENT IS THE PROPERTY OF MOORE AND ASSOCIATES ENGINEERING AND CONSULTING. THE UNAUTHORIZED REPRODUCTION, COPYING, OR OTHERWISE USE OF THIS DOCUMENT IS STRICTLY PROHIBITED AND ANY INFRINGEMENT THEREON MAY BE SUBJECT TO LEGAL ACTION.

Longh.

Longh.

Longh.

BASE RAIL ANCHORAGE OPTIONS

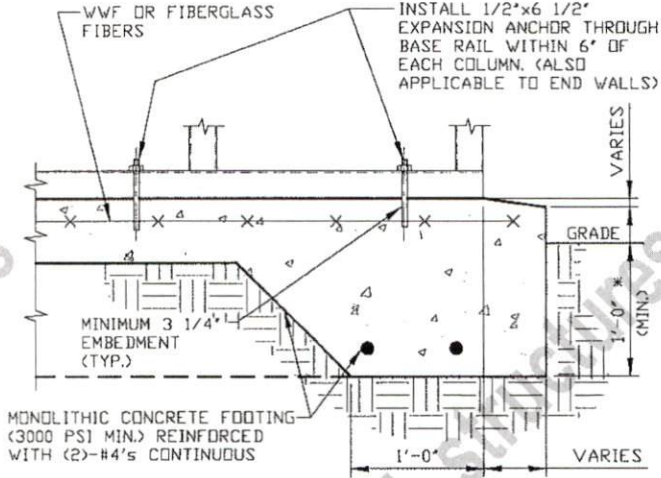
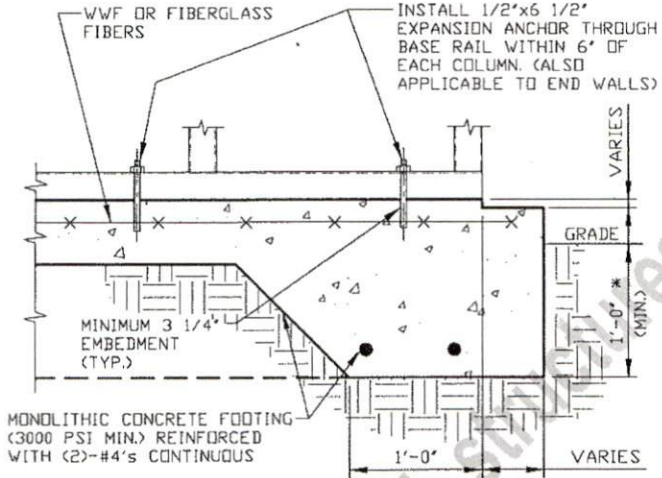

2 CONCRETE MONOLITHIC SLAB BASE RAIL ANCHORAGE
 SCALE: NTS
 MINIMUM ANCHOR EDGE DISTANCE IS 4".
 * COORDINATE WITH LOCAL CODES/ORD.
 REGARDING MINIMUM FROST DEPTH REQ.

2A CONCRETE SLAB BASE RAIL ANCHORAGE
 SCALE: NTS
 MINIMUM ANCHOR EDGE DISTANCE IS 4".
 * COORDINATE WITH LOCAL CODES/ORD.
 REGARDING MINIMUM FROST DEPTH REQ.

GENERAL NOTES

NOTE: CONCRETE MONOLITHIC SLAB DESIGN BASED ON MINIMUM SOIL BEARING CAPACITY OF 1,500 PSF.

CONCRETE:

CONCRETE SHALL HAVE A MINIMUM SPECIFIED COMPRESSIVE STRENGTH OF 3,000 PSI AT 28 DAYS.

COVER OVER REINFORCING STEEL:

FOR FOUNDATIONS, MINIMUM CONCRETE COVER OVER REINFORCING BARS SHALL BE PER ACI-318.
 3" IN FOUNDATIONS WHERE THE CONCRETE IS CAST AGAINST AND PERMANENTLY IN CONTACT WITH THE EARTH OR EXPOSED TO THE EARTH OR WEATHER, AND 1 1/2" ELSEWHERE.

REINFORCING STEEL:

THE TURNDOWN REINFORCING STEEL SHALL BE ASTM A615 GRADE 60. THE SLAB REINFORCEMENT SHALL BE WELDED WIRE FABRIC MEETING ASTM A185 OR FIBERGLASS FIBER REINFORCEMENT.

REINFORCEMENT MAY BE BENT IN THE SHOP OR THE FIELD PROVIDED:

1. REINFORCEMENT IS BENT COLD.
2. THE DIAMETER OF THE BEND, MEASURED ON THE INSIDE OF THE BAR, IS NOT LESS THAN SIX-BAR DIAMETERS.
3. REINFORCEMENT PARTIALLY EMBEDDED IN CONCRETE SHALL NOT BE FIELD BENT.

MOORE AND ASSOCIATES
 ENGINEERING AND CONSULTING, INC.

DRAWN BY: JG
 CHECKED BY: PDH
 PROJECT MGR: WSM
 CLIENT: LONGHORN

LONGHORN STEEL STRUCTURES, INC.
 272 HICKORY STREET
 MOUNT AIRY, NC 27030
 30'-0" x 16'-0" ENCLOSED STRUCTURE

DATE: 1-6-21
 SCALE: NTS
 SHT. 9
 JOB NO: 20310S
 Dwg. NO: SK-3
 REV: 0

THIS DOCUMENT IS THE PROPERTY OF MOORE AND ASSOCIATES ENGINEERING AND CONSULTING. THE UNAUTHORIZED REPRODUCTION, COPYING, OR OTHERWISE USE OF THIS DOCUMENT IS STRICTLY PROHIBITED AND ANY INFRINGEMENT THEREON MAY BE SUBJECT TO LEGAL ACTION.

Longh.

Longh.

Longh.

BASE RAIL ANCHORAGE OPTION

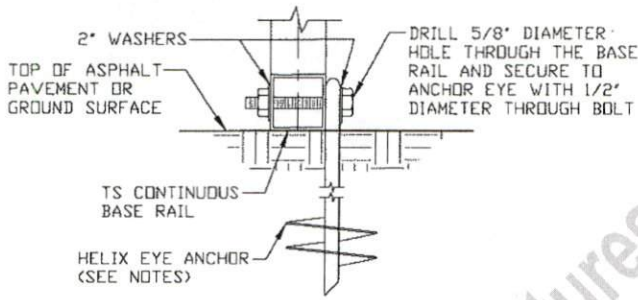

2B **GROUND BASE HELIX ANCHORAGE**
 SCALE: NTS
 (CAN BE USED FOR ASPHALT)
 * COORDINATE WITH LOCAL CODES/ORD. REGARDING MINIMUM FROST DEPTH REQ.

HELIX ANCHOR NOTES:

1. FOR VERY DENSE AND/OR CEMENTED SANDS, COARSE GRAVEL AND COBBLES, GRAVELLITE, PRELOADED SILTS AND CLAYS, USE MINIMUM (2) 4" HELICES WITH MINIMUM 30" EMBEDMENT OR SINGLE 6" HELIX WITH MINIMUM 50" EMBEDMENT.
2. FOR COARSE USE MINIMUM (2) 4" HELICES WITH MINIMUM 30" EMBEDMENT OR SINGLE 6" HELIX WITH MINIMUM 50" EMBEDMENT.
3. FOR MEDIUM DENSE COARSE SANDS, SANDY GRAVELS, VERY STIFF SILTS, AND CLAYS USE MINIMUM (2) 4" HELICES WITH MINIMUM 30 INCH EMBEDMENT OR SINGLE 6" HELIX WITH MINIMUM 50" EMBEDMENT.
4. FOR LOOSE TO MEDIUM DENSE SANDS, FIRM TO STIFF CLAYS AND SILTS ALLUVIAL FILL, USE MINIMUM (2) 6" HELICES WITH MINIMUM 50" EMBEDMENT.
5. FOR VERY LOSE TO MEDIUM DENSE SANDS, FIRM TO STIFFER CLAYS AND SILTS, ALLUVIAL FILL, USE MINIMUM (2) 8" HELICES WITH MINIMUM 60" EMBEDMENT.

MOORE AND ASSOCIATES
 ENGINEERING AND CONSULTING, INC.

DRAWN BY: JG

CHECKED BY: PDH

PROJECT MGR: WSM

CLIENT: LONGHORN

LONGHORN STEEL STRUCTURES, INC.
 272 HICKORY STREET
 MOUNT AIRY, NC 27030
 30'-0" x 16'-0" ENCLOSED STRUCTURE

DATE: 1-6-21

SHT. 9A

SCALE: NTS

DWG. NO: SK-3

JOB NO: 20310S

REV: 0

THIS DOCUMENT IS THE PROPERTY OF MOORE AND ASSOCIATES ENGINEERING AND CONSULTING. THE UNAUTHORIZED REPRODUCTION, COPYING, OR OTHERWISE USE OF THIS DOCUMENT IS STRICTLY PROHIBITED AND ANY INFRINGEMENT THEREON MAY BE SUBJECT TO LEGAL ACTION.

Longi.

Longi.

Longi.

BOX EAVE RAFTER END WALL AND SIDE WALL FRAMING SECTIONS

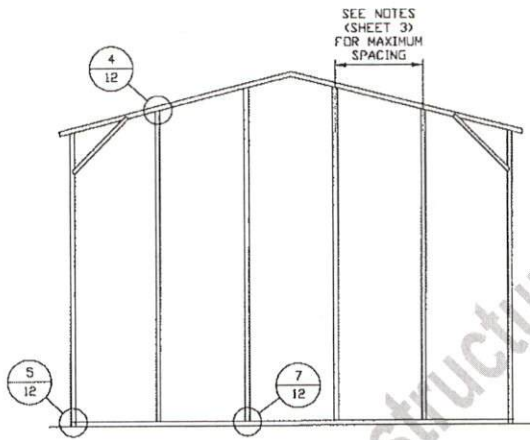

**TYPICAL BOX EAVE RAFTER
END WALL FRAMING SECTION**
SCALE: NTS

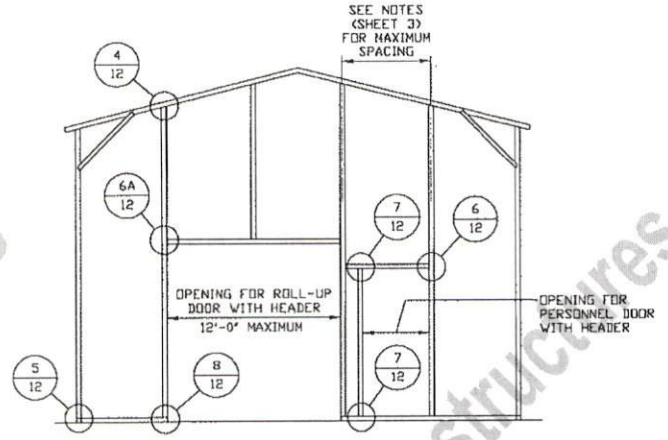

**TYPICAL BOX EAVE RAFTER END
WALL OPENINGS FRAMING SECTION**
SCALE: NTS

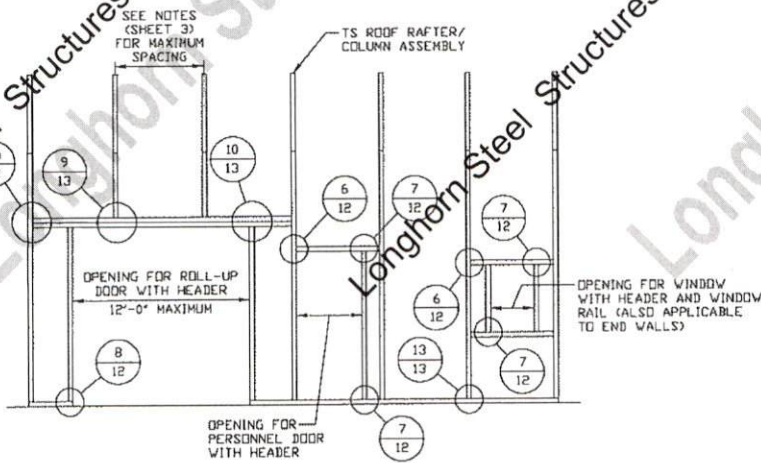

**TYPICAL BOX EAVE RAFTER
SIDE WALL OPENINGS FRAMING SECTION**
SCALE: NTS

MOORE AND ASSOCIATES
ENGINEERING AND CONSULTING, INC.

DRAWN BY: JG

CHECKED BY: PDH

PROJECT MGR: WSM

CLIENT: LONGHORN

LONGHORN STEEL STRUCTURES, INC.
272 HICKORY STREET
MOUNT AIRY, NC 27030
30'-0" x 16'-0" ENCLOSED STRUCTURE

DATE: 1-6-21

SCALE: NTS

JOB NO: 20310S

SHT. 10

SWG. NO: SK-3

REV: 0

THIS DOCUMENT IS THE PROPERTY OF MOORE AND ASSOCIATES ENGINEERING AND CONSULTING. THE UNAUTHORIZED REPRODUCTION, COPYING, OR OTHERWISE USE OF THIS DOCUMENT IS STRICTLY PROHIBITED AND ANY INFRINGEMENT THEREON MAY BE SUBJECT TO LEGAL ACTION.

BOW EAVE RAFTER END WALL AND SIDE WALL FRAMING SECTIONS

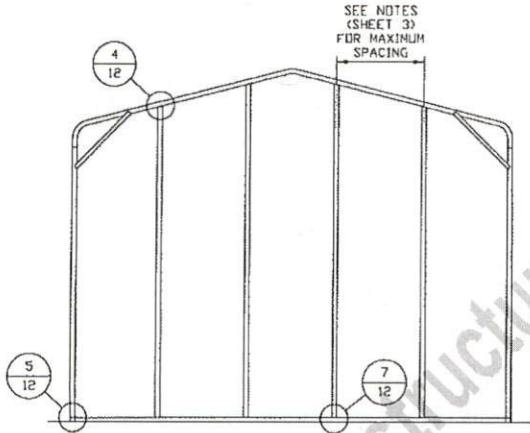

TYPICAL BOW EAVE RAFTER
END WALL FRAMING SECTION

SCALE: NTS

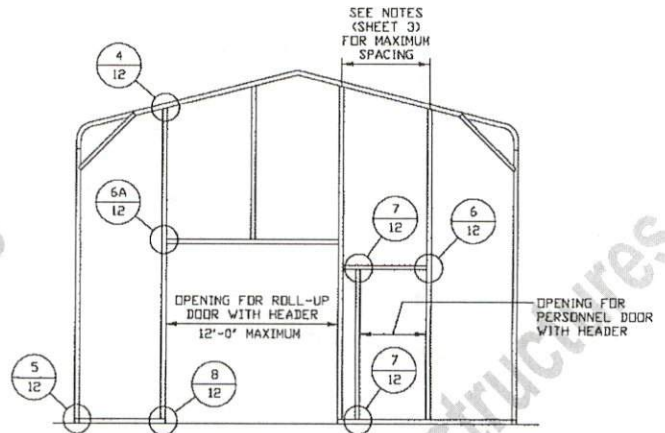

TYPICAL BOW EAVE RAFTER END
WALL OPENINGS FRAMING SECTION

SCALE: NTS

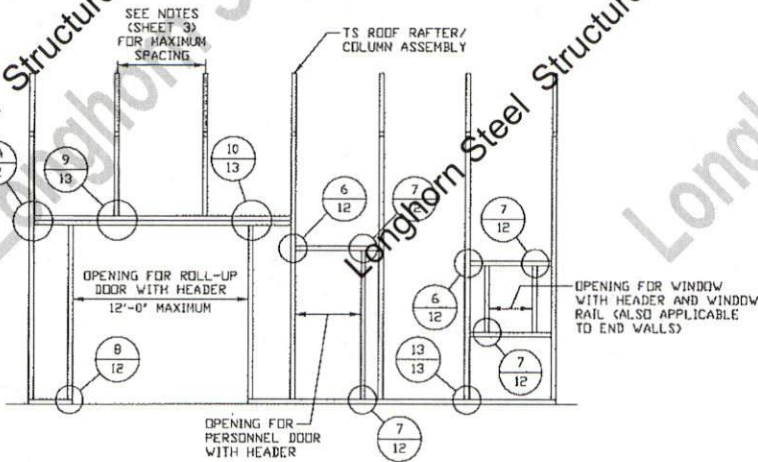

TYPICAL BOW EAVE RAFTER
SIDE WALL OPENINGS FRAMING SECTION

SCALE: NTS

MOORE AND ASSOCIATES
ENGINEERING AND CONSULTING, INC.

DRAWN BY: JG

CHECKED BY: PDH

PROJECT MGR: WSM

CLIENT: LONGHORN

LONGHORN STEEL STRUCTURES, INC.
272 HICKORY STREET
MOUNT AIRY, NC 27030
30'-0" x 16'-0" ENCLOSED STRUCTURE

DATE: 1-6-21

SCALE: NTS

JOB NO: 20310S

SHT. 11

FIG. NO: SK-3

REV: 0

THIS DOCUMENT IS THE PROPERTY OF MOORE AND ASSOCIATES ENGINEERING AND CONSULTING. THE UNAUTHORIZED REPRODUCTION, COPYING, OR OTHERWISE USE OF THIS DOCUMENT IS STRICTLY PROHIBITED AND ANY INFRINGEMENT THEREON MAY BE SUBJECT TO LEGAL ACTION.

Longi.

Longi.

Longi.

CONNECTION DETAILS

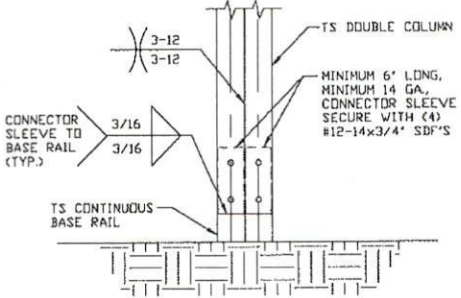

3 POST/BASE RAIL CONNECTION DETAIL
SCALE: NTS

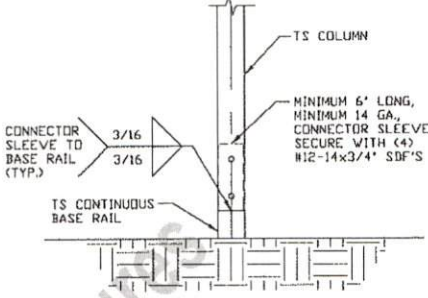

3A POST/BASE RAIL CONNECTION DETAIL
SCALE: NTS



4 END COLUMN/RAFTER CONNECTION DETAIL
SCALE: NTS

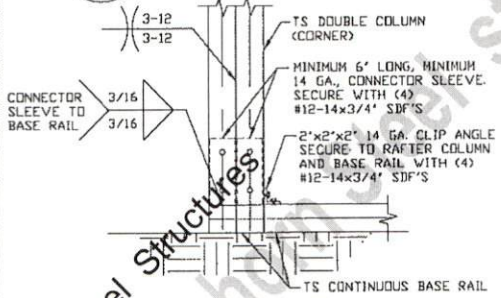

5 END COLUMN/BASE RAIL CONNECTION DETAIL
SCALE: NTS

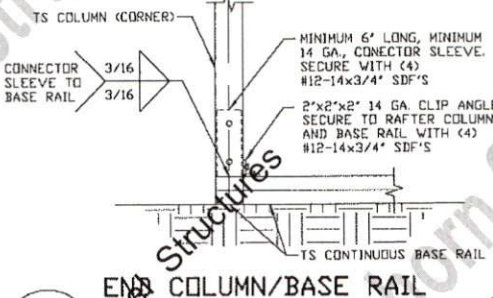

5A END COLUMN/BASE RAIL CONNECTION DETAIL
SCALE: NTS

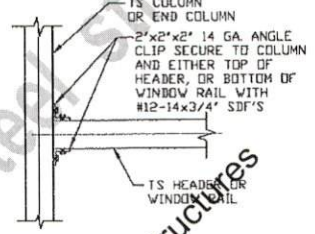

6 COLUMN OR WINDOW RAIL TO POST CONNECTION DETAIL
SCALE: NTS

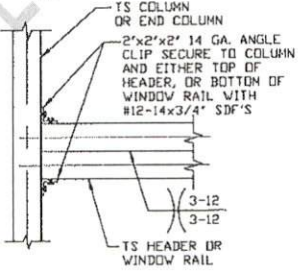

6A COLUMN OR WINDOW RAIL TO POST CONNECTION DETAIL
SCALE: NTS

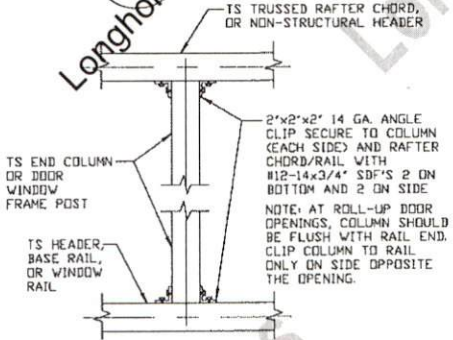

7 COLUMN TO HEADER, BASE RAIL, OR WINDOW RAIL CONNECTION DETAIL
SCALE: NTS

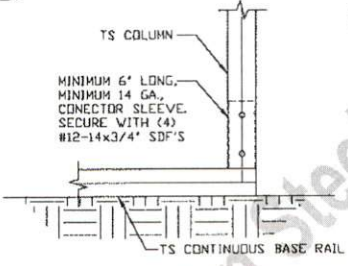

8 COLUMN/BASE RAIL CONNECTION DETAIL
SCALE: NTS

MOORE AND ASSOCIATES ENGINEERING AND CONSULTING, INC.

DRAWN BY: JG
CHECKED BY: PDH

LONGHORN STEEL STRUCTURES, INC.
272 HICKORY STREET
MOUNT AIRY, NC 27030
30'-0" x 16'-0" ENCLOSED STRUCTURE

THIS DOCUMENT IS THE PROPERTY OF MOORE AND ASSOCIATES ENGINEERING AND CONSULTING. THE UNAUTHORIZED REPRODUCTION, COPYING, OR OTHERWISE USE OF THIS DOCUMENT IS STRICTLY PROHIBITED AND ANY INFRINGEMENT THEREON MAY BE SUBJECT TO LEGAL ACTION.

PROJECT MGR: WSM
CLIENT: LONGHORN

DATE: 1-6-21
SHT. 12
SCALE: NTS
JOB NO: 20310S
REV: 0
DWG. NO: SK-3

Longi.

Longi.

Longi.

CONNECTION DETAILS

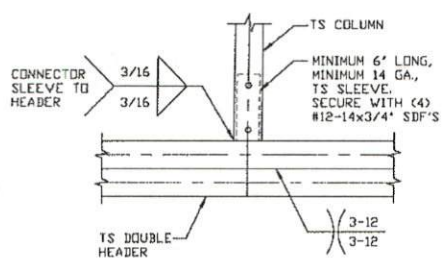

9 COLUMN/DOUBLE HEADER CONNECTION DETAIL
SCALE: NTS

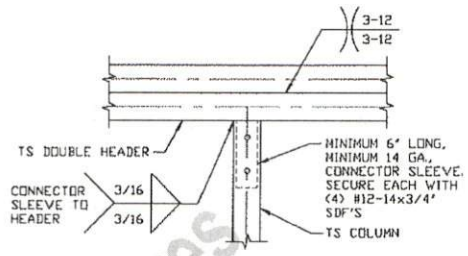

10 DOUBLE HEADER/COLUMN CONNECTION DETAIL
SCALE: NTS

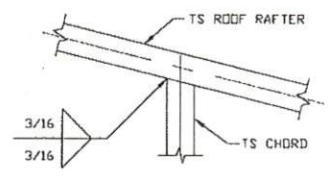

11 RAFTER TO CHORD CONNECTION DETAIL
SCALE: NTS

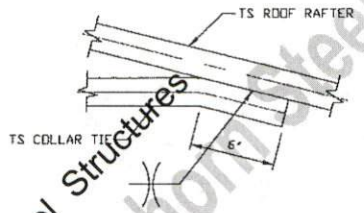

12 COLLAR TIE CONNECTION DETAIL
SCALE: NTS

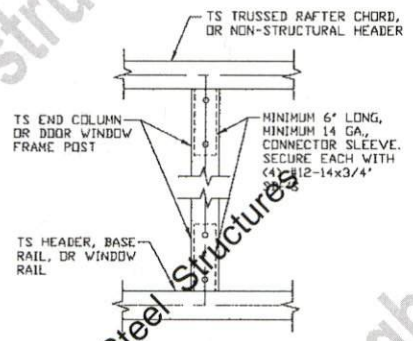

13 COLUMN TO HEADER OR BASE RAIL CONNECTION DETAIL
SCALE: NTS

MOORE AND ASSOCIATES
ENGINEERING AND CONSULTING, INC.

DRAWN BY: JG
CHECKED BY: PDH
PROJECT MGR: WSM
CLIENT: LONGHORN

LONGHORN STEEL STRUCTURES, INC.
272 HICKORY STREET
MOUNT AIRY, NC 27030
30'-0" x 16'-0" ENCLOSED STRUCTURE

THIS DOCUMENT IS THE PROPERTY OF MOORE AND ASSOCIATES ENGINEERING AND CONSULTING. THE UNAUTHORIZED REPRODUCTION, COPYING, OR OTHERWISE USE OF THIS DOCUMENT IS STRICTLY PROHIBITED AND ANY INFRINGEMENT THEREON MAY BE SUBJECT TO LEGAL ACTION.

DATE: 1-6-21
SCALE: NTS
JOB NO: 20310S
SHT. 13
DWG. NO: SK-3
REV: 0

BOX EAVE RAFTER LEAN-TO OPTIONS

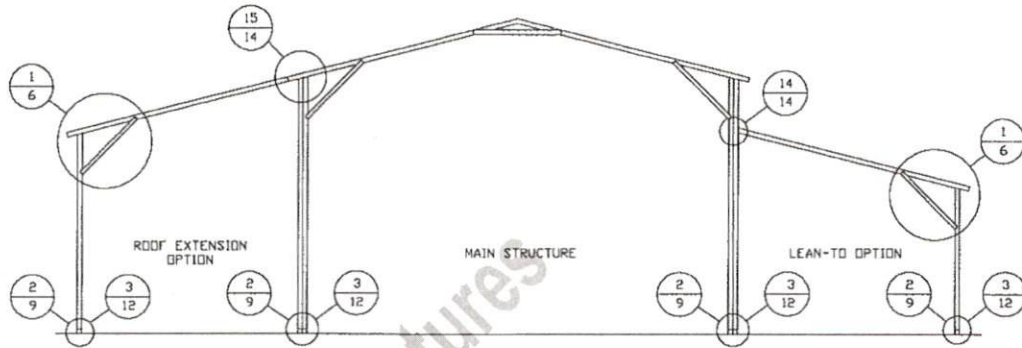

TYPICAL BOX EAVE RAFTER LEAN-TO OPTIONS FRAMING SECTION (BOTH OPTIONS SHOWN)

SCALE: NTS

RAFTER COLUMNS USED IN A LEAN-TO CONFIGURATION ARE DOUBLE COLUMN FOR HEIGHTS 10'-0" < TO ≤ 16'-0"

RAFTER COLUMNS USED IN A LEAN-TO CONFIGURATION ARE SINGLE COLUMN FOR HEIGHTS ≤ 10'-0"

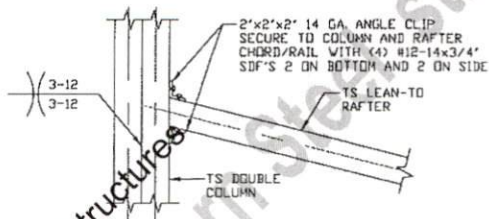

LEAN-TO RAFTER TO RAFTER COLUMN CONNECTION DETAIL FOR RAFTER SPANS ≤ 12'-0"

SCALE: NTS

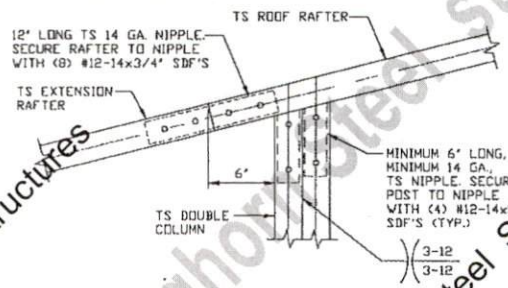

SIDE EXTENSION RAFTER COLUMN DETAIL FOR SPANS ≤ 12'-0"

SCALE: NTS

**MOORE AND ASSOCIATES
ENGINEERING AND CONSULTING, INC.**

DRAWN BY: JG

CHECKED BY: PDH

PROJECT MGR: WSM

CLIENT: LONGHORN

LONGHORN STEEL STRUCTURES, INC.
272 HICKORY STREET
MOUNT AIRY, NC 27030
30'-0" x 16'-0" ENCLOSED STRUCTURE

DATE: 1-6-21

SHT. 14

SCALE: NTS

FIG. NO: SK-3

JOB NO: 20310S

REV: 0

THIS DOCUMENT IS THE PROPERTY OF MOORE AND ASSOCIATES ENGINEERING AND CONSULTING, INC. UNAUTHORIZED REPRODUCTION, COPYING, OR OTHERWISE USE OF THIS DOCUMENT IS STRICTLY PROHIBITED AND ANY INFRINGEMENT THEREON MAY BE SUBJECT TO LEGAL ACTION.

BOW EAVE RAFTER LEAN-TO OPTIONS

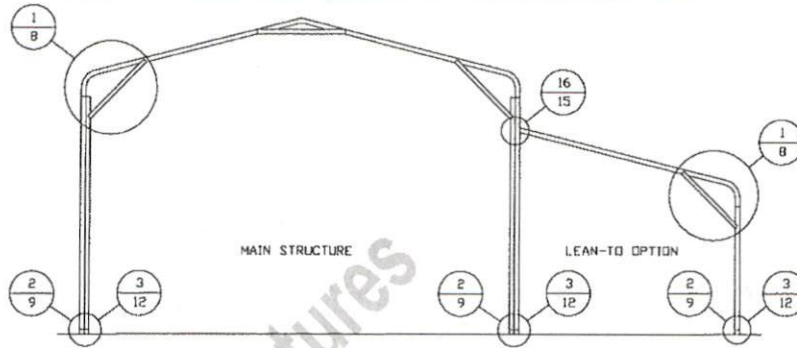

TYPICAL BOW EAVE RAFTER LEAN-TO OPTIONS FRAMING SECTION

SCALE: NTS

RAFTER COLUMNS USED IN A LEAN-TO CONFIGURATION ARE DOUBLE COLUMN FOR HEIGHTS 10'-0" < TO ≤ 16'-0"
 RAFTER COLUMNS USED IN A LEAN-TO CONFIGURATION ARE SINGLE COLUMN FOR HEIGHTS ≤ 10'-0"

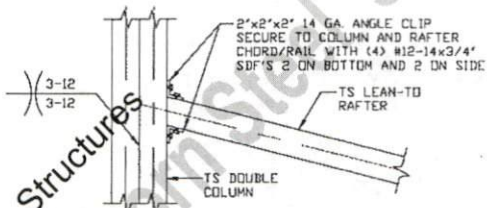

LEAN-TO RAFTER TO RAFTER COLUMN CONNECTION DETAIL FOR RAFTER SPANS ≤ 12'-0"

SCALE: NTS

16

MOORE AND ASSOCIATES
 ENGINEERING AND CONSULTING, INC.

DRAWN BY: JG

CHECKED BY: PDH

PROJECT MGR: WSM

CLIENT: LONGHORN

LONGHORN STEEL STRUCTURES, INC.
 272 HICKORY STREET
 MOUNT AIRY, NC 27030
 30'-0" x 16'-0" ENCLOSED STRUCTURE

DATE: 1-6-21

SCALE: NTS

JOB NO: 20310S

SHT. 15

DWG. NO: SK-3

REV: 0

THIS DOCUMENT IS THE PROPERTY OF MOORE AND ASSOCIATES ENGINEERING AND CONSULTING. THE UNAUTHORIZED REPRODUCTION, COPYING, OR OTHERWISE USE OF THIS DOCUMENT IS STRICTLY PROHIBITED AND ANY INFRINGEMENT THEREON MAY BE SUBJECT TO LEGAL ACTION.

BOX EAVE RAFTER VERTICAL ROOF/SIDING OPTION

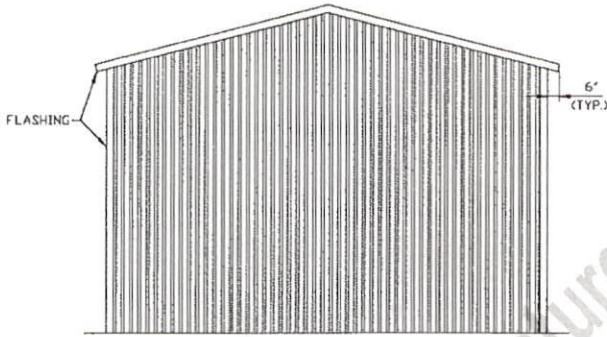

**TYPICAL END ELEVATION
VERTICAL ROOF/SIDING**

SCALE: NTS

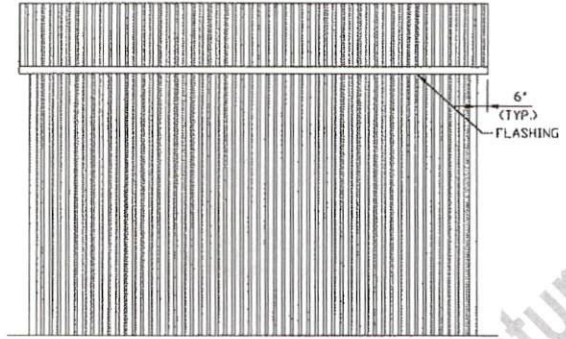

**TYPICAL SIDE ELEVATION
VERTICAL ROOF/SIDING**

SCALE: NTS

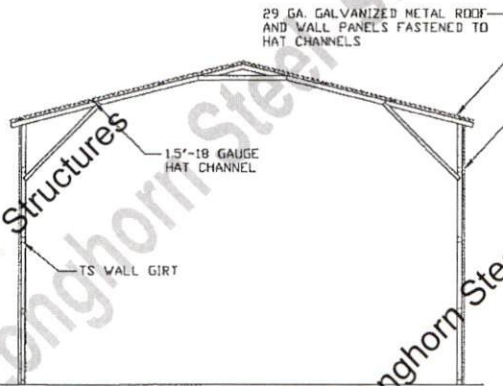

**TYPICAL SECTION VERTICAL
ROOF/SIDING OPTION**

SCALE: NTS

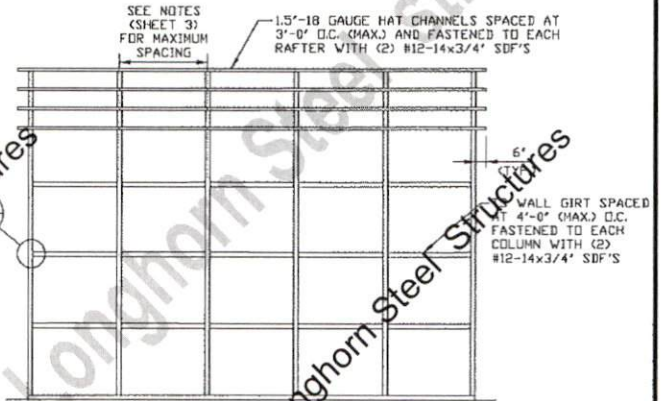

**TYPICAL FRAMING SECTION VERTICAL
ROOF/SIDING OPTION WITH TS GIRTS**

SCALE: NTS

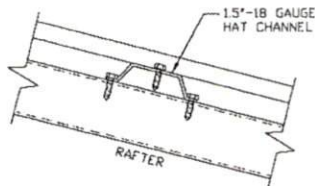

PANEL ATTACHMENT

(ALTERNATE FOR VERTICAL ROOF PANELS)
SCALE: NTS

**MOORE AND ASSOCIATES
ENGINEERING AND CONSULTING, INC.**

DRAWN BY: JG

CHECKED BY: PDH

PROJECT MGR: WSM

CLIENT: LONGHORN

LONGHORN STEEL STRUCTURES, INC.
272 HICKORY STREET
MOUNT AIRY, NC 27030
30'-0" x 16'-0" ENCLOSED STRUCTURE

DATE: 1-6-21

SCALE: NTS

JOB NO: 20310S

SHT. 16

DRG. NO: SK-3

REV: 0

THIS DOCUMENT IS THE PROPERTY OF MOORE AND ASSOCIATES ENGINEERING AND CONSULTING. THE UNAUTHORIZED REPRODUCTION, COPYING, OR OTHERWISE USE OF THIS DOCUMENT IS STRICTLY PROHIBITED AND ANY INFRINGEMENT THEREON MAY BE SUBJECT TO LEGAL ACTION.