

# Mark Morris, P.E.

#126, 1317-M, Summerville, SC 29483

843 209-5784, Fax (866)-213-4614

The truss drawing(s) listed below have been prepared by **Atlantic Building Components** under my direct supervision based on the parameters provided by the truss designers.

AST #: 28709

JOB: 21-5120-R01

JOB NAME: LOT 17 VILLAS @ ANDERSON CREEK

Wind Code: 37

Wind Speed: Vult= 130mph

Exposure Category: B

Mean Roof Height (feet): 23

These truss designs comply with IRC 2015 as well as IRC 2018.

*27 Truss Design(s)*

Trusses:

M01, M02, M04, M05, PB01, PB02, R01, R02, R03, R04, R05, R06, R07, R08, R10, R11, R12, VT01, VT02, VT03, VT04, VT05, VT06, VT07, VT08, VT09, VT10



**9/29/2021**

**Mark Morris**

***Warning !—Verify design parameters and read notes before use.***

This design is based only upon parameters shown, and is for an individual building component to be installed and loaded vertically. Applicability of design parameters and proper incorporation of component is responsibility of building designer – not truss designer or truss engineer. Bracing shown is for lateral support of individual web members only. Additional temporary bracing to ensure stability during construction is the responsibility of the erector. Additional permanent bracing of the overall structure is the responsibility of the building designer. For general guidance regarding fabrication, quality control, storage, delivery, erection and bracing, consult ANSI/TPI 1 *National Design Standard for Metal Plate Connected Wood Truss Construction* and BCSI 1-03 *Guide to Good Practice for*

Job	Truss	Truss Type	Qty	Ply	LOT 17 VILLAS @ ANDERSON CREEK   66 HAWK RIDGE DRIVE SPRING LAKE, NC
21-5120-R01	M01	GABLE	1	1	

Job Reference (optional) # 28709

8.430 s Feb 12 2021 MiTek Industries, Inc. Thu Sep 30 15:45:05 2021 Page 1

ID:xwDXRRIPWrQwmU1uH5\_sXuyd8cO-6?LQHKtXDhiW52GAK78fYQvtd3DntCOAbIFHByYPey

5-11-8  
3-8-0

Scale = 1:14.8

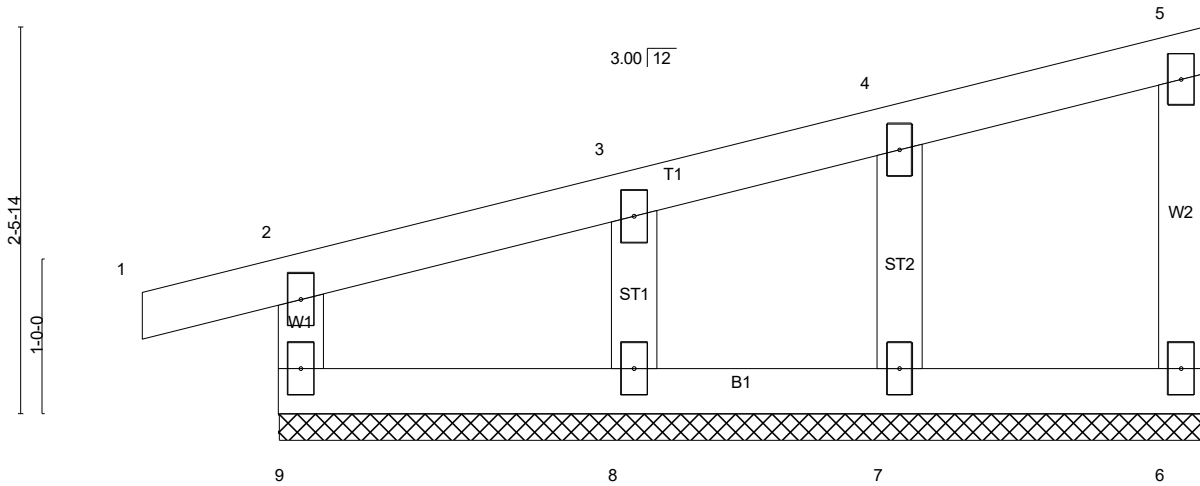

<b>LOADING</b> (psf)	<b>SPACING-</b>	<b>CSI.</b>	<b>DEFL.</b>	<b>PLATES</b>	<b>GRIP</b>
TCLL (roof) 20.0	2-0-0	TC 0.23	in (loc) l/defl L/d	MT20	244/190
Snow (Pf) 20.0	Plate Grip DOL 1.15	BC 0.13	Vert(LL) -0.00 1 n/r 180		
TCDL 10.0	Lumber DOL 1.15	WB 0.06	Vert(CT) -0.00 1 n/r 80		
BCLL 0.0 *	Rep Stress Incr YES	Matrix-R	Horz(CT) -0.00 6 n/a n/a		
BCDL 10.0	Code IRC2018/TPI2014			Weight: 27 lb	FT = 20%

**LUMBER-**  
TOP CHORD 2x4 SP No.2  
BOT CHORD 2x4 SP No.3  
WEBS 2x4 SP No.3  
OTHERS 2x4 SP No.3

**BRACING-**  
TOP CHORD Structural wood sheathing directly applied or 5-11-8 oc purlins, except end verticals.  
BOT CHORD Rigid ceiling directly applied or 6-0-0 oc bracing.  
MiTek recommends that Stabilizers and required cross bracing be installed during truss erection, in accordance with Stabilizer Installation guide.

**REACTIONS.** All bearings 5-11-8.  
(lb) - Max Horz 9=52(LC 10)  
Max Uplift All uplift 100 lb or less at joint(s) 9, 6, 7, 8  
Max Grav All reactions 250 lb or less at joint(s) 9, 6, 7, 8

**FORCES.** (lb) - Max. Comp./Max. Ten. - All forces 250 (lb) or less except when shown.

**NOTES-** (14-17)

- Wind: ASCE 7-16; Vult=130mph (3-second gust) Vasd=103mph; TCDL=5.0psf; BCDL=5.0psf; h=23ft; Cat. II; Exp B; Enclosed; MWFRS (envelope) gable end zone and C-C Corner(3E) zone; end vertical left exposed; porch left exposed;C-C for members and forces & MWFRS for reactions shown; Lumber DOL=1.60 plate grip DOL=1.60
- Truss designed for wind loads in the plane of the truss only. For studs exposed to wind (normal to the face), see Standard Industry Gable End Details as applicable, or consult qualified building designer as per ANSI/TPI 1.
- TCLL: ASCE 7-16; Pr=20.0 psf (roof LL: Lum DOL=1.15 Plate DOL=1.15); Pf=20.0 psf (Lum DOL=1.15 Plate DOL=1.15); Is=1.0; Rough Cat B; Partially Exp.; Ce=1.0; Cs=1.00; Ct=1.10
- Unbalanced snow loads have been considered for this design.
- This truss has been designed for greater of min roof live load of 12.0 psf or 2.00 times flat roof load of 20.0 psf on overhangs non-concurrent with other live loads.
- All plates are 2x4 MT20 unless otherwise indicated.
- Gable requires continuous bottom chord bearing.
- Truss to be fully sheathed from one face or securely braced against lateral movement (i.e. diagonal web).
- Gable studs spaced at 2-0-0 oc.
- This truss has been designed for a 10.0 psf bottom chord live load nonconcurrent with any other live loads.
- \* This truss has been designed for a live load of 30.0psf on the bottom chord in all areas where a rectangle 3-6-0 tall by 1-0-0 wide will fit between the bottom chord and any other members.
- Provide mechanical connection (by others) of truss to bearing plate capable of withstanding 100 lb uplift at joint(s) 9, 6, 7, 8.
- This truss is designed in accordance with the 2018 International Residential Code sections R502.11.1 and R802.10.2 and referenced standard ANSI/TPI 1.



9/29/2021

Continued on page 2. Design parameters and read notes before use. This design is based only upon parameters shown, and is for an individual building component to be installed and loaded vertically. Applicability of design parameters and proper incorporation of component is responsibility of building designer – not truss designer or truss engineer. Bracing shown is for lateral support of individual web members only. Additional temporary bracing to ensure stability during construction is the responsibility of the erector. Additional permanent bracing of the overall structure is the responsibility of the building designer. For general guidance regarding fabrication, quality control, storage, delivery, erection and bracing, consult ANSI/TPI 1 *National Design Standard for Metal Plate Connected Wood Truss Construction* and BCSI 1-03 *Guide to Good Practice for Handling, Installing & Bracing of Metal Plate Connected Wood Trusses* from Truss Plate Institute, 583 D'Onofrio Drive, Madison, WI 53719.

Job	Truss	Truss Type	Qty	Ply	LOT 17 VILLAS @ ANDERSON CREEK   66 HAWK RIDGE DRIVE SPRING LAKE, NC
21-5120-R01	M01	GABLE	1	1	Job Reference (optional) # 28709

8.430 s Feb 12 2021 MiTek Industries, Inc. Thu Sep 30 15:45:06 2021 Page 2

ID: xwDXRRIPWrQwmU1uH5\_sXuyd8cO-aBvpVfu9\_?qNiCrMlqfu5dS2N2PSWKRYPE2pqdyYPex

- 14) Graphical bracing representation does not depict the size, type or the orientation of the brace on the member. Symbol only indicates that the member must be braced.
- 15) Bearing symbols are only graphical representations of a possible bearing condition. Bearing symbols are not considered in the structural design of the truss to support the loads indicated.
- 16) Web bracing shown is for lateral support of individual web members only. Refer to BCSI - Guide to Good Practice for Handling, Installing, Restraining & Bracing of Metal Plate Connected Wood Trusses for additional bracing guidelines, including diagonal bracing.
- 17) SEE BCSI-B3 SUMMARY SHEET- PERMANENT RESTRAING/BRACING OF CHORDS & WEB MEMBERS FOR RECOMMENDED MINIMUM BRACING REQUIREMENTS OF TOP CHORD, BOTTOM CHORD, AND WEB PLANES. IN ADDITION TO THESE MINIMUM GUIDELINES, ALWAYS CONSULT THE PROJECT ARCHITECT OR ENGINEER FOR ADDITIONAL BRACING CONSIDERATIONS.

**LOAD CASE(S)** Standard



9/29/2021

**Warning !—Verify design parameters and read notes before use.** This design is based only upon parameters shown, and is for an individual building component to be installed and loaded vertically. Applicability of design parameters and proper incorporation of component is responsibility of building designer – not truss designer or truss engineer. Bracing shown is for lateral support of individual web members only. Additional temporary bracing to ensure stability during construction is the responsibility of the erector. Additional permanent bracing of the overall structure is the responsibility of the building designer. For general guidance regarding fabrication, quality control, storage, delivery, erection and bracing, consult ANSI/TPI 1 *National Design Standard for Metal Plate Connected Wood Truss Construction* and BCSI 1-03 *Guide to Good Practice for Handling, Installing & Bracing of Metal Plate Connected Wood Trusses* from Truss Plate Institute, 583 D'Onofrio Drive, Madison, WI 53719.



Scale = 1:16.2

<b>LOADING</b> (psf)	<b>SPACING-</b>	<b>CSI.</b>	<b>DEFL.</b>	<b>PLATES</b>	<b>GRIP</b>
TCLL (roof) 20.0	2-0-0	TC 0.89	in (loc) l/defl L/d	MT20	244/190
Snow (Pf) 20.0	Plate Grip DOL 1.15	BC 0.15	Vert(LL) 0.02 5-6 >999 240		
TCDL 10.0	Lumber DOL 1.15	WB 0.09	Vert(CT) -0.01 5-6 >999 180		
BCLL 0.0 *	Rep Stress Incr YES	Matrix-P	Horz(CT) -0.00 5 n/a n/a		
BCDL 10.0	Code IRC2018/TPI2014			Weight: 32 lb	FT = 20%

**LUMBER-**  
 TOP CHORD 2x4 SP No.2  
 BOT CHORD 2x4 SP No.2  
 WEBS 2x4 SP No.3

**BRACING-**  
 TOP CHORD Structural wood sheathing directly applied or 2-2-0 oc purlins, except end verticals.  
 BOT CHORD Rigid ceiling directly applied or 10-0-0 oc bracing.  
 MiTek recommends that Stabilizers and required cross bracing be installed during truss erection, in accordance with Stabilizer Installation guide.

**REACTIONS.** (lb/size) 6=191/0-3-8 (min. 0-1-8), 5=323/0-3-8 (min. 0-1-8)  
 Max Horz 6=52(LC 10)  
 Max Uplift 6=-81(LC 10), 5=-113(LC 10)  
 Max Grav 6=255(LC 21), 5=418(LC 21)

**FORCES.** (lb) - Max. Comp./Max. Ten. - All forces 250 (lb) or less except when shown.  
 TOP CHORD 2-3=-217/288  
 WEBS 3-5=-371/255, 2-5=-241/288

- NOTES-** (9-12)
- Wind: ASCE 7-16; Vult=130mph (3-second gust) Vasd=103mph; TCDL=5.0psf; BCDL=5.0psf; h=23ft; Cat. II; Exp B; Enclosed; MWFRS (envelope) gable end zone and C-C Exterior(2E) zone; cantilever right exposed; end vertical left exposed; porch left exposed; C-C for members and forces & MWFRS for reactions shown; Lumber DOL=1.60 plate grip DOL=1.60
  - TCLL: ASCE 7-16; Pr=20.0 psf (roof LL: Lum DOL=1.15 Plate DOL=1.15); Pf=20.0 psf (Lum DOL=1.15 Plate DOL=1.15); Is=1.0; Rough Cat B; Partially Exp.; Ce=1.0; Cs=1.00; Ct=1.10
  - Unbalanced snow loads have been considered for this design.
  - This truss has been designed for greater of min roof live load of 12.0 psf or 2.00 times flat roof load of 20.0 psf on overhangs non-concurrent with other live loads.
  - This truss has been designed for a 10.0 psf bottom chord live load nonconcurrent with any other live loads.
  - \* This truss has been designed for a live load of 30.0psf on the bottom chord in all areas where a rectangle 3-6-0 tall by 1-0-0 wide will fit between the bottom chord and any other members.
  - Provide mechanical connection (by others) of truss to bearing plate capable of withstanding 100 lb uplift at joint(s) 6 except (jt=lb) 5=113.
  - This truss is designed in accordance with the 2018 International Residential Code sections R502.11.1 and R802.10.2 and referenced standard ANSI/TPI 1.
  - Graphical bracing representation does not depict the size, type or the orientation of the brace on the member. Symbol only indicates that the member must be braced.
  - Bearing symbols are only graphical representations of a possible bearing condition. Bearing symbols are not considered in the structural design of the truss to support the loads indicated.
  - Web bracing shown is for lateral support of individual web members only. Refer to BCSI - Guide to Good Practice for Handling, Installing, Restraining & Bracing of Metal Plate Connected Wood Trusses for additional bracing guidelines, including diagonal bracing.
  - SEE BCSI-B3 SUMMARY SHEET- PERMANENT RESTRAINING/BRACING OF CHORDS & WEB MEMBERS FOR RECOMMENDED MINIMUM BRACING REQUIREMENTS OF TOP CHORD, BOTTOM CHORD, AND WEB PLANES. IN ADDITION TO THESE MINIMUM GUIDELINES, ALWAYS CONSULT THE PROJECT ARCHITECT OR ENGINEER FOR ADDITIONAL BRACING CONSIDERATIONS.

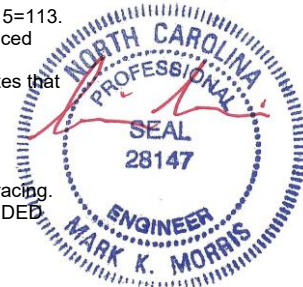

**LOAD CASE(S)** Standard

9/29/2021

**Warning !—Verify design parameters and read notes before use.** This design is based only upon parameters shown, and is for an individual building component to be installed and loaded vertically. Applicability of design parameters and proper incorporation of component is responsibility of building designer – not truss designer or truss engineer. Bracing shown is for lateral support of individual web members only. Additional temporary bracing to ensure stability during construction is the responsibility of the erector. Additional permanent bracing of the overall structure is the responsibility of the building designer. For general guidance regarding fabrication, quality control, storage, delivery, erection and bracing, consult ANSI/TPI 1 *National Design Standard for Metal Plate Connected Wood Truss Construction* and BCSI 1-03 *Guide to Good Practice for Handling, Installing & Bracing of Metal Plate Connected Wood Trusses* from Truss Plate Institute, 583 D'Onofrio Drive, Madison, WI 53719.

Job	Truss	Truss Type	Qty	Ply	LOT 17 VILLAS @ ANDERSON CREEK   66 HAWK RIDGE DRIVE SPRING LAKE, NC
21-5120-R01	M04	GABLE	2	1	Job Reference (optional) # 28709

8.430 s Feb 12 2021 MiTek Industries, Inc. Thu Sep 30 15:45:07 2021 Page 1  
 ID:xwDXRRIPWwQwmU1uH5\_sXuyd8cO-2OTBi?vnJyEKMqZsYA7dr\_D5RkZFnmheunMM4yYPew



Scale = 1:17.1

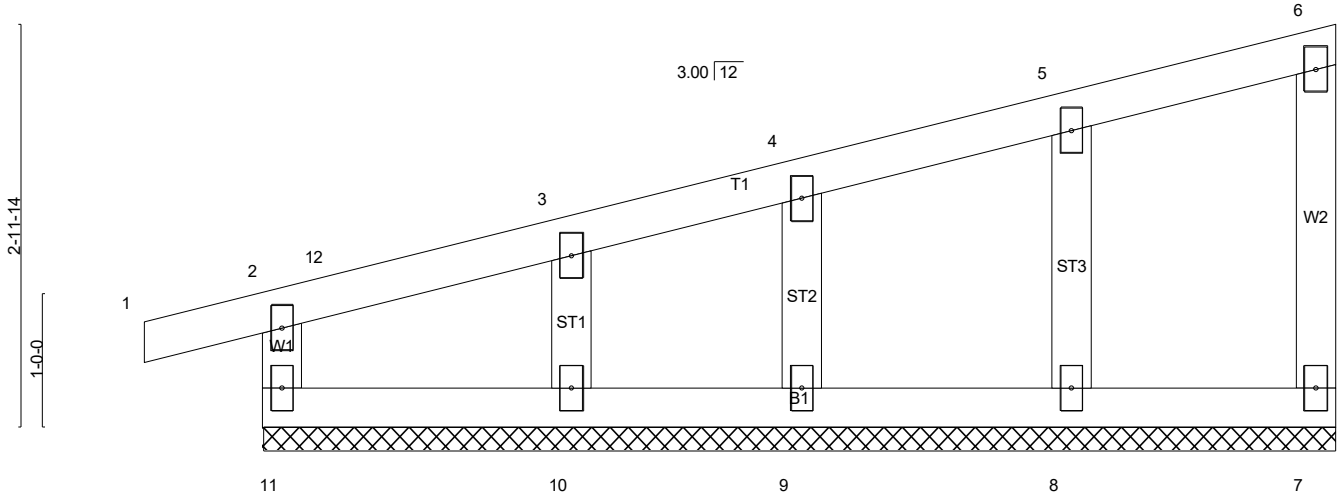

<b>LOADING</b> (psf)	<b>SPACING-</b>	<b>CSI.</b>	<b>DEFL.</b>	<b>PLATES</b>	<b>GRIP</b>
TCLL (roof) 20.0	2-0-0	TC 0.23	in (loc) l/defl L/d	MT20	244/190
Snow (Pf) 20.0	Plate Grip DOL 1.15	BC 0.13	Vert(LL) -0.00 1 n/r 180		
TCDL 10.0	Lumber DOL 1.15	WB 0.05	Vert(CT) -0.00 1 n/r 80		
BCLL 0.0 *	Rep Stress Incr YES	Matrix-R	Horz(CT) -0.00 7 n/a n/a		
BCDL 10.0	Code IRC2018/TPI2014			Weight: 36 lb	FT = 20%

**LUMBER-**  
 TOP CHORD 2x4 SP No.2  
 BOT CHORD 2x4 SP No.3  
 WEBS 2x4 SP No.3  
 OTHERS 2x4 SP No.3

**BRACING-**  
 TOP CHORD Structural wood sheathing directly applied or 6-0-0 oc purlins, except end verticals.  
 BOT CHORD Rigid ceiling directly applied or 6-0-0 oc bracing.  
 MiTek recommends that Stabilizers and required cross bracing be installed during truss erection, in accordance with Stabilizer Installation guide.

**REACTIONS.** All bearings 7-11-8.  
 (lb) - Max Horz 11=81(LC 10)  
 Max Uplift All uplift 100 lb or less at joint(s) 11, 7, 9, 8, 10  
 Max Grav All reactions 250 lb or less at joint(s) 11, 7, 9, 8, 10

**FORCES.** (lb) - Max. Comp./Max. Ten. - All forces 250 (lb) or less except when shown.

**NOTES-** (14-17)

- 1) Wind: ASCE 7-16; Vult=130mph (3-second gust) Vasd=103mph; TCDL=5.0psf; BCDL=5.0psf; h=23ft; Cat. II; Exp B; Enclosed; MWFRS (envelope) gable end zone and C-C Corner(3E) zone;C-C for members and forces & MWFRS for reactions shown; Lumber DOL=1.60 plate grip DOL=1.60
- 2) Truss designed for wind loads in the plane of the truss only. For studs exposed to wind (normal to the face), see Standard Industry Gable End Details as applicable, or consult qualified building designer as per ANSI/TPI 1.
- 3) TCLL: ASCE 7-16; Pr=20.0 psf (roof LL: Lum DOL=1.15 Plate DOL=1.15); Pf=20.0 psf (Lum DOL=1.15 Plate DOL=1.15); Is=1.0; Rough Cat B; Partially Exp.; Ce=1.0; Cs=1.00; Ct=1.10
- 4) Unbalanced snow loads have been considered for this design.
- 5) This truss has been designed for greater of min roof live load of 12.0 psf or 2.00 times flat roof load of 20.0 psf on overhangs non-concurrent with other live loads.
- 6) All plates are 2x4 MT20 unless otherwise indicated.
- 7) Gable requires continuous bottom chord bearing.
- 8) Truss to be fully sheathed from one face or securely braced against lateral movement (i.e. diagonal web).
- 9) Gable studs spaced at 2-0-0 oc.
- 10) This truss has been designed for a 10.0 psf bottom chord live load nonconcurrent with any other live loads.
- 11) \* This truss has been designed for a live load of 30.0psf on the bottom chord in all areas where a rectangle 3-6-0 tall by 1-0-0 wide will fit between the bottom chord and any other members.
- 12) Provide mechanical connection (by others) of truss to bearing plate capable of withstanding 100 lb uplift at joint(s) 11, 7, 9, 8, 10.
- 13) This truss is designed in accordance with the 2018 International Residential Code sections R502.11.1 and R802.10.2 and referenced standard ANSI/TPI 1.



9/29/2021

Continued on page 2  
 Design parameters and read notes before use. This design is based only upon parameters shown, and is for an individual building component to be installed and loaded vertically. Applicability of design parameters and proper incorporation of component is responsibility of building designer – not truss designer or truss engineer. Bracing shown is for lateral support of individual web members only. Additional temporary bracing to ensure stability during construction is the responsibility of the erector. Additional permanent bracing of the overall structure is the responsibility of the building designer. For general guidance regarding fabrication, quality control, storage, delivery, erection and bracing, consult ANSI/TPI 1 National Design Standard for Metal Plate Connected Wood Truss Construction and BCSI 1-03 Guide to Good Practice for Handling, Installing & Bracing of Metal Plate Connected Wood Trusses from Truss Plate Institute, 583 D'Onofrio Drive, Madison, WI 53719.

Job	Truss	Truss Type	Qty	Ply	LOT 17 VILLAS @ ANDERSON CREEK   66 HAWK RIDGE DRIVE SPRING LAKE, NC
21-5120-R01	M04	GABLE	2	1	Job Reference (optional) # 28709

8.430 s Feb 12 2021 MiTek Industries, Inc. Thu Sep 30 15:45:08 2021 Page 2  
 ID: xwDXRRIPWrQwmU1uH5\_sXuyd8cO-Wa1ZwLwPWc45yW?IPFiMA2XOrr4o\_E0rsYXwuWYYPev

- 14) Graphical bracing representation does not depict the size, type or the orientation of the brace on the member. Symbol only indicates that the member must be braced.
- 15) Bearing symbols are only graphical representations of a possible bearing condition. Bearing symbols are not considered in the structural design of the truss to support the loads indicated.
- 16) Web bracing shown is for lateral support of individual web members only. Refer to BCSI - Guide to Good Practice for Handling, Installing, Restraining & Bracing of Metal Plate Connected Wood Trusses for additional bracing guidelines, including diagonal bracing.
- 17) SEE BCSI-B3 SUMMARY SHEET- PERMANENT RESTRAING/BRACING OF CHORDS & WEB MEMBERS FOR RECOMMENDED MINIMUM BRACING REQUIREMENTS OF TOP CHORD, BOTTOM CHORD, AND WEB PLANES. IN ADDITION TO THESE MINIMUM GUIDELINES, ALWAYS CONSULT THE PROJECT ARCHITECT OR ENGINEER FOR ADDITIONAL BRACING CONSIDERATIONS.

**LOAD CASE(S)** Standard



9/29/2021

**Warning !—Verify design parameters and read notes before use.** This design is based only upon parameters shown, and is for an individual building component to be installed and loaded vertically. Applicability of design parameters and proper incorporation of component is responsibility of building designer – not truss designer or truss engineer. Bracing shown is for lateral support of individual web members only. Additional temporary bracing to ensure stability during construction is the responsibility of the erector. Additional permanent bracing of the overall structure is the responsibility of the building designer. For general guidance regarding fabrication, quality control, storage, delivery, erection and bracing, consult ANSI/TPI 1 *National Design Standard for Metal Plate Connected Wood Truss Construction* and BCSI 1-03 *Guide to Good Practice for Handling, Installing & Bracing of Metal Plate Connected Wood Trusses* from Truss Plate Institute, 583 D'Onofrio Drive, Madison, WI 53719.

Job	Truss	Truss Type	Qty	Ply	LOT 17 VILLAS @ ANDERSON CREEK   66 HAWK RIDGE DRIVE SPRING LAKE, NC	Job Reference (optional)	# 28709
21-5120-R01	M05	Monopitch	7	1			

ID:xwDXRRIPWrQwmU1uH5\_sXuyd8cO-Wa1ZwLwPWc45yW?IPFiMA2XP1r0T\_CxrsYXwuWYYPev 8.430 s Feb 12 2021 MiTek Industries, Inc. Thu Sep 30 15:45:08 2021 Page 1

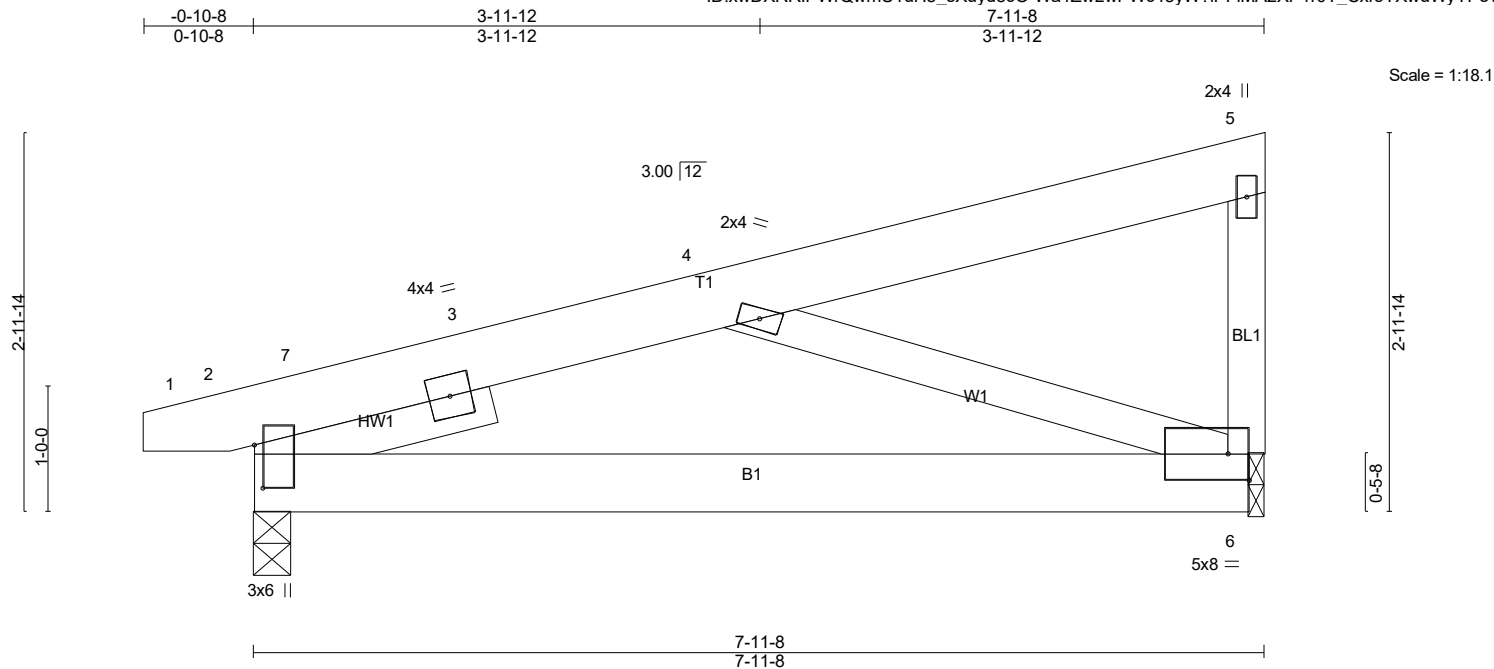

Plate Offsets (X,Y)-- [2:0-4-1.0-0-13]

LOADING (psf)	SPACING-	CSI.	DEFL.	in (loc)	l/defl	L/d	PLATES	GRIP
TCLL (roof) 20.0	2-0-0	TC 0.15	Vert(LL) 0.14	2-6	>658	240	MT20	244/190
Snow (Pf) 20.0	Plate Grip DOL 1.15	BC 0.41	Vert(CT) -0.12	2-6	>814	180		
TCDL 10.0	Lumber DOL 1.15	WB 0.19	Horz(CT) 0.00	6	n/a	n/a		
BCLL 0.0 *	Rep Stress Incr YES	Matrix-P						
BCDL 10.0	Code IRC2018/TPI2014						Weight: 52 lb	FT = 20%

**LUMBER-**  
TOP CHORD 2x6 SP No.2  
BOT CHORD 2x6 SP No.2  
WEBS 2x4 SP No.3  
OTHERS 2x4 SP No.3  
SLIDER Left 2x4 SP No.3 - 1-11-1

**BRACING-**  
TOP CHORD Structural wood sheathing directly applied or 6-0-0 oc purlins.  
BOT CHORD Rigid ceiling directly applied or 9-7-10 oc bracing.

MiTek recommends that Stabilizers and required cross bracing be installed during truss erection, in accordance with Stabilizer Installation guide.

**REACTIONS.** (lb/size) 2=346/0-3-8 (min. 0-1-8), 6=311/0-1-8 (min. 0-1-8)  
Max Horz 2=77(LC 14)  
Max Uplift 2=-136(LC 10), 6=-141(LC 10)  
Max Grav 2=425(LC 21), 6=403(LC 21)

**FORCES.** (lb) - Max. Comp./Max. Ten. - All forces 250 (lb) or less except when shown.  
TOP CHORD 2-7=-576/259, 3-7=-510/261, 3-4=-483/273  
BOT CHORD 2-6=-347/484  
WEBS 4-6=-512/367

**NOTES-** (11-14)

- 1) Wind: ASCE 7-16; Vult=130mph (3-second gust) Vasd=103mph; TCDL=5.0psf; BCDL=5.0psf; h=23ft; Cat. II; Exp B; Enclosed; MWFRS (envelope) gable end zone and C-C Exterior(2E) zone; porch left exposed; C-C for members and forces & MWFRS for reactions shown; Lumber DOL=1.60 plate grip DOL=1.60
- 2) TCLL: ASCE 7-16; Pr=20.0 psf (roof LL: Lum DOL=1.15 Plate DOL=1.15); Pf=20.0 psf (Lum DOL=1.15 Plate DOL=1.15); Is=1.0; Rough Cat B; Partially Exp.; Ce=1.0; Cs=1.00; Ct=1.10
- 3) Unbalanced snow loads have been considered for this design.
- 4) This truss has been designed for greater of min roof live load of 12.0 psf or 2.00 times flat roof load of 20.0 psf on overhangs non-concurrent with other live loads.
- 5) This truss has been designed for a 10.0 psf bottom chord live load nonconcurrent with any other live loads.
- 6) \* This truss has been designed for a live load of 30.0psf on the bottom chord in all areas where a rectangle 3-6-0 tall by 1-0-0 wide will fit between the bottom chord and any other members.
- 7) Bearing at joint(s) 6 considers parallel to grain value using ANSI/TPI 1 angle to grain formula. Building designer should verify capacity of bearing surface.
- 8) Provide mechanical connection (by others) of truss to bearing plate at joint(s) 6.
- 9) Provide mechanical connection (by others) of truss to bearing plate capable of withstanding 100 lb uplift at joint(s) except (jt=lb) 2=136, 6=141.
- 10) This truss is designed in accordance with the 2018 International Residential Code sections R502.11.1 and R802.10.2 and referenced standard ANSI/TPI 1.

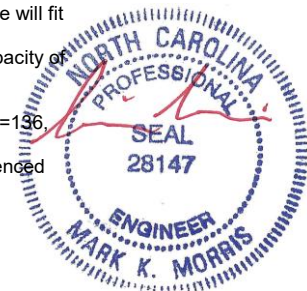

9/29/2021

Continued on Page 2 Design parameters and read notes before use. This design is based only upon parameters shown, and is for an individual building component to be installed and loaded vertically. Applicability of design parameters and proper incorporation of component is responsibility of building designer – not truss designer or truss engineer. Bracing shown is for lateral support of individual web members only. Additional temporary bracing to ensure stability during construction is the responsibility of the erector. Additional permanent bracing of the overall structure is the responsibility of the building designer. For general guidance regarding fabrication, quality control, storage, delivery, erection and bracing, consult ANSI/TPI 1 National Design Standard for Metal Plate Connected Wood Truss Construction and BCSI 1-03 Guide to Good Practice for Handling, Installing & Bracing of Metal Plate Connected Wood Trusses from Truss Plate Institute, 583 D'Onofrio Drive, Madison, WI 53719.

Job	Truss	Truss Type	Qty	Ply	LOT 17 VILLAS @ ANDERSON CREEK   66 HAWK RIDGE DRIVE SPRING LAKE, NC
21-5120-R01	M05	Monopitch	7	1	Job Reference (optional) # 28709

8.430 s Feb 12 2021 MiTek Industries, Inc. Thu Sep 30 15:45:09 2021 Page 2

ID:xwDXRRIPWrQwmU1uH5\_sXuyd8cO-?max7hw1HwCxZfaxzzDbiG4anFLijfB\_5CGTQyyYPeu

- 11) Graphical bracing representation does not depict the size, type or the orientation of the brace on the member. Symbol only indicates that the member must be braced.
- 12) Bearing symbols are only graphical representations of a possible bearing condition. Bearing symbols are not considered in the structural design of the truss to support the loads indicated.
- 13) Web bracing shown is for lateral support of individual web members only. Refer to BCSI - Guide to Good Practice for Handling, Installing, Restraining & Bracing of Metal Plate Connected Wood Trusses for additional bracing guidelines, including diagonal bracing.
- 14) SEE BCSI-B3 SUMMARY SHEET- PERMANENT RESTRAING/BRACING OF CHORDS & WEB MEMBERS FOR RECOMMENDED MINIMUM BRACING REQUIREMENTS OF TOP CHORD, BOTTOM CHORD, AND WEB PLANES. IN ADDITION TO THESE MINIMUM GUIDELINES, ALWAYS CONSULT THE PROJECT ARCHITECT OR ENGINEER FOR ADDITIONAL BRACING CONSIDERATIONS.

**LOAD CASE(S)** Standard



9/29/2021

**Warning !—Verify design parameters and read notes before use.** This design is based only upon parameters shown, and is for an individual building component to be installed and loaded vertically. Applicability of design parameters and proper incorporation of component is responsibility of building designer – not truss designer or truss engineer. Bracing shown is for lateral support of individual web members only. Additional temporary bracing to ensure stability during construction is the responsibility of the erector. Additional permanent bracing of the overall structure is the responsibility of the building designer. For general guidance regarding fabrication, quality control, storage, delivery, erection and bracing, consult ANSI/TPI 1 *National Design Standard for Metal Plate Connected Wood Truss Construction* and BCSI 1-03 *Guide to Good Practice for Handling, Installing & Bracing of Metal Plate Connected Wood Trusses* from Truss Plate Institute, 583 D'Onofrio Drive, Madison, WI 53719.



Job	Truss	Truss Type	Qty	Ply	LOT 17 VILLAS @ ANDERSON CREEK   66 HAWK RIDGE DRIVE SPRING LAKE,
21-5120-R01	PB01	Piggyback	1	1	Job Reference (optional) # 28709

8.430 s Feb 12 2021 MiTek Industries, Inc. Thu Sep 30 15:45:09 2021 Page 1  
 ID:xwDXRRIPWwQwmU1uH5\_sXuyd8cO-?max7hw1HwCxZfaxzzDbiG4bNFQEjhB\_5CGTQyyYPeu

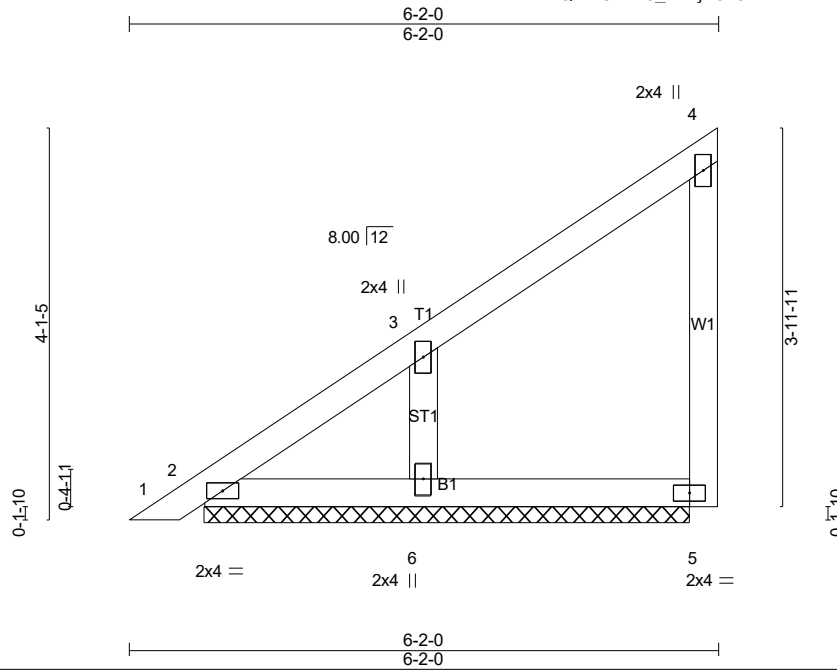

Scale: 1/2"=1'

<b>LOADING</b> (psf)	<b>SPACING-</b>	<b>CSI.</b>	<b>DEFL.</b>	<b>PLATES</b>	<b>GRIP</b>
TCLL (roof) 20.0	2-0-0	TC 0.12	in (loc) l/defl L/d	MT20	244/190
Snow (Pf) 20.0	Plate Grip DOL 1.15	BC 0.12	Vert(LL) -0.00 1 n/r 180		
TCDL 10.0	Lumber DOL 1.15	WB 0.06	Vert(CT) 0.00 1 n/r 80		
BCDL 0.0 *	Rep Stress Incr YES	Matrix-P	Horz(CT) 0.00 n/a n/a		
BCDL 10.0	Code IRC2018/TPI2014			Weight: 26 lb	FT = 20%

**LUMBER-**  
 TOP CHORD 2x4 SP No.2  
 BOT CHORD 2x4 SP No.3  
 WEBS 2x4 SP No.3  
 OTHERS 2x4 SP No.3

**BRACING-**  
 TOP CHORD Structural wood sheathing directly applied or 6'-0-0 oc purlins, except end verticals.  
 BOT CHORD Rigid ceiling directly applied or 10'-0-0 oc bracing.  
 MiTek recommends that Stabilizers and required cross bracing be installed during truss erection, in accordance with Stabilizer Installation guide.

**REACTIONS.** (lb/size) 5=94/5-1-0 (min. 0-1-8), 2=97/5-1-0 (min. 0-1-8), 6=259/5-1-0 (min. 0-1-8)  
 Max Horz 2=136(LC 12)  
 Max Uplift 5=-37(LC 12), 6=-106(LC 12)  
 Max Grav 5=99(LC 20), 2=97(LC 1), 6=273(LC 20)

**FORCES.** (lb) - Max. Comp./Max. Ten. - All forces 250 (lb) or less except when shown.

**NOTES-** (10-13)

- 1) Wind: ASCE 7-16; Vult=130mph (3-second gust) Vasd=103mph; TCDL=5.0psf; BCDL=5.0psf; h=23ft; Cat. II; Exp B; Enclosed; MWFRS (envelope) gable end zone and C-C Exterior(2E) zone; C-C for members and forces & MWFRS for reactions shown; Lumber DOL=1.60 plate grip DOL=1.60
- 2) TCLL: ASCE 7-16; Pr=20.0 psf (roof LL: Lum DOL=1.15 Plate DOL=1.15); Pf=20.0 psf (Lum DOL=1.15 Plate DOL=1.15); Is=1.0; Rough Cat B; Partially Exp.; Ce=1.0; Cs=1.00; Ct=1.10
- 3) This truss has been designed for greater of min roof live load of 12.0 psf or 2.00 times flat roof load of 20.0 psf on overhangs non-concurrent with other live loads.
- 4) Gable requires continuous bottom chord bearing.
- 5) This truss has been designed for a 10.0 psf bottom chord live load nonconcurrent with any other live loads.
- 6) \* This truss has been designed for a live load of 30.0psf on the bottom chord in all areas where a rectangle 3'-6-0 tall by 1'-0-0 wide will fit between the bottom chord and any other members.
- 7) Provide mechanical connection (by others) of truss to bearing plate capable of withstanding 100 lb uplift at joint(s) 5 except (jt=lb) 6=106.
- 8) This truss is designed in accordance with the 2018 International Residential Code sections R502.11.1 and R802.10.2 and referenced standard ANSI/TPI 1.
- 9) See Standard Industry Piggyback Truss Connection Detail for Connection to base truss as applicable, or consult qualified building designer.
- 10) Graphical bracing representation does not depict the size, type or the orientation of the brace on the member. Symbol only indicates that the member must be braced.
- 11) Bearing symbols are only graphical representations of a possible bearing condition. Bearing symbols are not considered in the structural design of the truss to support the loads indicated.
- 12) Web bracing shown is for lateral support of individual web members only. Refer to BCSI - Guide to Good Practice for Handling, Installing, Restraining & Bracing of Metal Plate Connected Wood Trusses for additional bracing guidelines, including diagonal bracing.
- 13) SEE BCSI-B3 SUMMARY SHEET- PERMANENT RESTRAINING/BRACING OF CHORDS & WEB MEMBERS FOR RECOMMENDED MINIMUM BRACING REQUIREMENTS OF TOP CHORD, BOTTOM CHORD, AND WEB PLANES. IN ADDITION TO THESE MINIMUM GUIDELINES, ALWAYS CONSULT THE PROJECT ARCHITECT OR ENGINEER FOR ADDITIONAL BRACING CONSIDERATIONS.

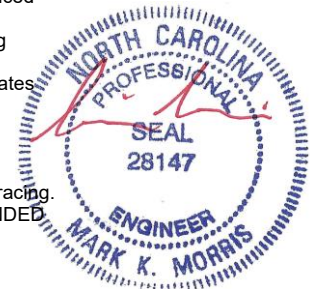

9/29/2021

**LOAD CASE(S)** Standard

**Warning !—Verify design parameters and read notes before use.** This design is based only upon parameters shown, and is for an individual building component to be installed and loaded vertically. Applicability of design parameters and proper incorporation of component is responsibility of building designer – not truss designer or truss engineer. Bracing shown is for lateral support of individual web members only. Additional temporary bracing to ensure stability during construction is the responsibility of the erector. Additional permanent bracing of the overall structure is the responsibility of the building designer. For general guidance regarding fabrication, quality control, storage, delivery, erection and bracing, consult ANSI/TPI 1 *National Design Standard for Metal Plate Connected Wood Truss Construction* and BCSI 1-03 *Guide to Good Practice for Handling, Installing & Bracing of Metal Plate Connected Wood Trusses* from Truss Plate Institute, 583 D'Onofrio Drive, Madison, WI 53719.

Job	Truss	Truss Type	Qty	Ply	LOT 17 VILLAS @ ANDERSON CREEK   66 HAWK RIDGE DRIVE SPRING LAKE, NC	Job Reference (optional)
21-5120-R01	PB02	Piggyback	6	1		# 28709

8.430 s Feb 12 2021 MiTek Industries, Inc. Thu Sep 30 15:45:10 2021 Page 1  
 ID: xwDXRRIPWrQwmU1uH5\_sXuyd8cO-Tz8JL1xf2EKO-Bp98XgkqFTclwfiGS8O8Ks00zPyYPet

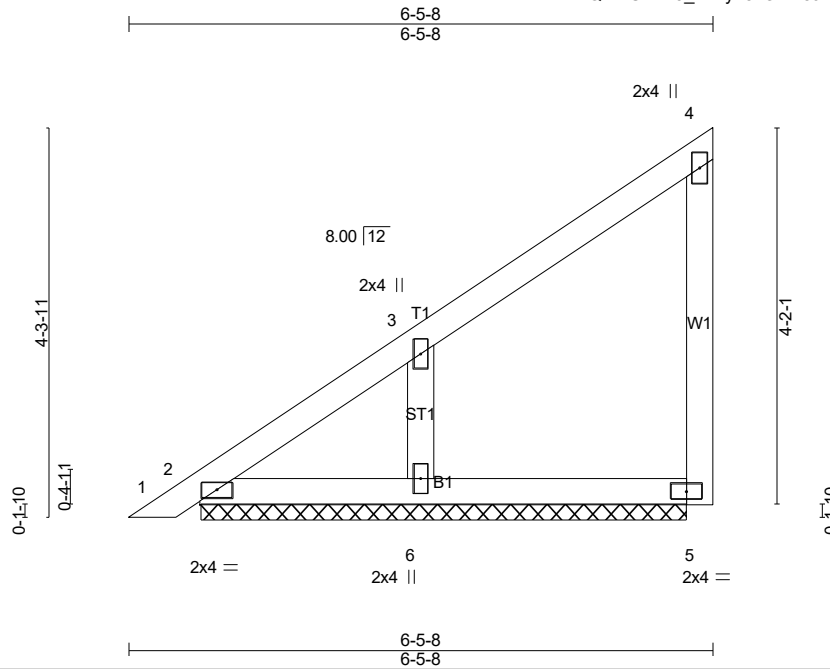

Scale = 1:25.5

LOADING (psf)	SPACING-	CSI.	DEFL.	PLATES	GRIP
TCLL (roof) 20.0	2-0-0	TC 0.13	in (loc) l/defl L/d	MT20	244/190
Snow (Pf) 20.0	Plate Grip DOL 1.15	BC 0.13	Vert(LL) -0.00 1 n/r 180		
TCDL 10.0	Lumber DOL 1.15	WB 0.06	Vert(CT) 0.00 1 n/r 80		
BCLL 0.0 *	Rep Stress Incr YES	Matrix-P	Horz(CT) 0.00 n/a n/a		
BCDL 10.0	Code IRC2018/TPI2014			Weight: 27 lb	FT = 20%

**LUMBER-**  
 TOP CHORD 2x4 SP No.2  
 BOT CHORD 2x4 SP No.3  
 WEBS 2x4 SP No.3  
 OTHERS 2x4 SP No.3

**BRACING-**  
 TOP CHORD Structural wood sheathing directly applied or 6-0-0 oc purlins, except end verticals.  
 BOT CHORD Rigid ceiling directly applied or 10-0-0 oc bracing.  
 MiTek recommends that Stabilizers and required cross bracing be installed during truss erection, in accordance with Stabilizer Installation guide.

**REACTIONS.** (lb/size) 5=98/5-4-8 (min. 0-1-8), 2=101/5-4-8 (min. 0-1-8), 6=274/5-4-8 (min. 0-1-8)  
 Max Horz 2=143(LC 12)  
 Max Uplift 5=39(LC 12), 6=112(LC 12)  
 Max Grav 5=103(LC 24), 2=101(LC 1), 6=289(LC 20)

**FORCES.** (lb) - Max. Comp./Max. Ten. - All forces 250 (lb) or less except when shown.

**NOTES-** (10-13)

- 1) Wind: ASCE 7-16; Vult=130mph (3-second gust) Vasd=103mph; TCDL=5.0psf; BCDL=5.0psf; h=23ft; Cat. II; Exp B; Enclosed; MWFRS (envelope) gable end zone and C-C Exterior(2E) zone; C-C for members and forces & MWFRS for reactions shown; Lumber DOL=1.60 plate grip DOL=1.60
- 2) TCLL: ASCE 7-16; Pr=20.0 psf (roof LL: Lum DOL=1.15 Plate DOL=1.15); Pf=20.0 psf (Lum DOL=1.15 Plate DOL=1.15); Is=1.0; Rough Cat B; Partially Exp.; Ce=1.0; Cs=1.00; Ct=1.10
- 3) This truss has been designed for greater of min roof live load of 12.0 psf or 2.00 times flat roof load of 20.0 psf on overhangs non-concurrent with other live loads.
- 4) Gable requires continuous bottom chord bearing.
- 5) This truss has been designed for a 10.0 psf bottom chord live load nonconcurrent with any other live loads.
- 6) \* This truss has been designed for a live load of 30.0psf on the bottom chord in all areas where a rectangle 3-6-0 tall by 1-0-0 wide will fit between the bottom chord and any other members.
- 7) Provide mechanical connection (by others) of truss to bearing plate capable of withstanding 100 lb uplift at joint(s) 5 except (jt=lb) 6=112.
- 8) This truss is designed in accordance with the 2018 International Residential Code sections R502.11.1 and R802.10.2 and referenced standard ANSI/TPI 1.
- 9) See Standard Industry Piggyback Truss Connection Detail for Connection to base truss as applicable, or consult qualified building designer.
- 10) Graphical bracing representation does not depict the size, type or the orientation of the brace on the member. Symbol only indicates that the member must be braced.
- 11) Bearing symbols are only graphical representations of a possible bearing condition. Bearing symbols are not considered in the structural design of the truss to support the loads indicated.
- 12) Web bracing shown is for lateral support of individual web members only. Refer to BCSI - Guide to Good Practice for Handling, Installing, Restraining & Bracing of Metal Plate Connected Wood Trusses for additional bracing guidelines, including diagonal bracing.
- 13) SEE BCSI-B3 SUMMARY SHEET- PERMANENT RESTRAINING/BRACING OF CHORDS & WEB MEMBERS FOR RECOMMENDED MINIMUM BRACING REQUIREMENTS OF TOP CHORD, BOTTOM CHORD, AND WEB PLANES. IN ADDITION TO THESE MINIMUM GUIDELINES, ALWAYS CONSULT THE PROJECT ARCHITECT OR ENGINEER FOR ADDITIONAL BRACING CONSIDERATIONS.

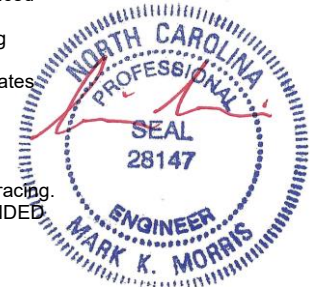

9/29/2021

**LOAD CASE(S)** Standard

**Warning !—Verify design parameters and read notes before use.** This design is based only upon parameters shown, and is for an individual building component to be installed and loaded vertically. Applicability of design parameters and proper incorporation of component is responsibility of building designer – not truss designer or truss engineer. Bracing shown is for lateral support of individual web members only. Additional temporary bracing to ensure stability during construction is the responsibility of the erector. Additional permanent bracing of the overall structure is the responsibility of the building designer. For general guidance regarding fabrication, quality control, storage, delivery, erection and bracing, consult ANSI/TPI 1 *National Design Standard for Metal Plate Connected Wood Truss Construction* and BCSI 1-03 *Guide to Good Practice for Handling, Installing & Bracing of Metal Plate Connected Wood Trusses* from Truss Plate Institute, 583 D'Onofrio Drive, Madison, WI 53719.

Job	Truss	Truss Type	Qty	Ply	LOT 17 VILLAS @ ANDERSON CREEK   66 HAWK RIDGE DRIVE SPRING LAKE, NC
21-5120-R01	R01	GABLE	1	1	# 28709

8.430 s Feb 12 2021 MiTek Industries, Inc. Thu Sep 30 15:45:12 2021 Page 1  
 ID:xdXRRIPWrQwmU1uH5\_sXuyd8cO-PLG4ljzwaraWQ7IWe5mlKui3GSPSw\_9QnAV71HyYPer

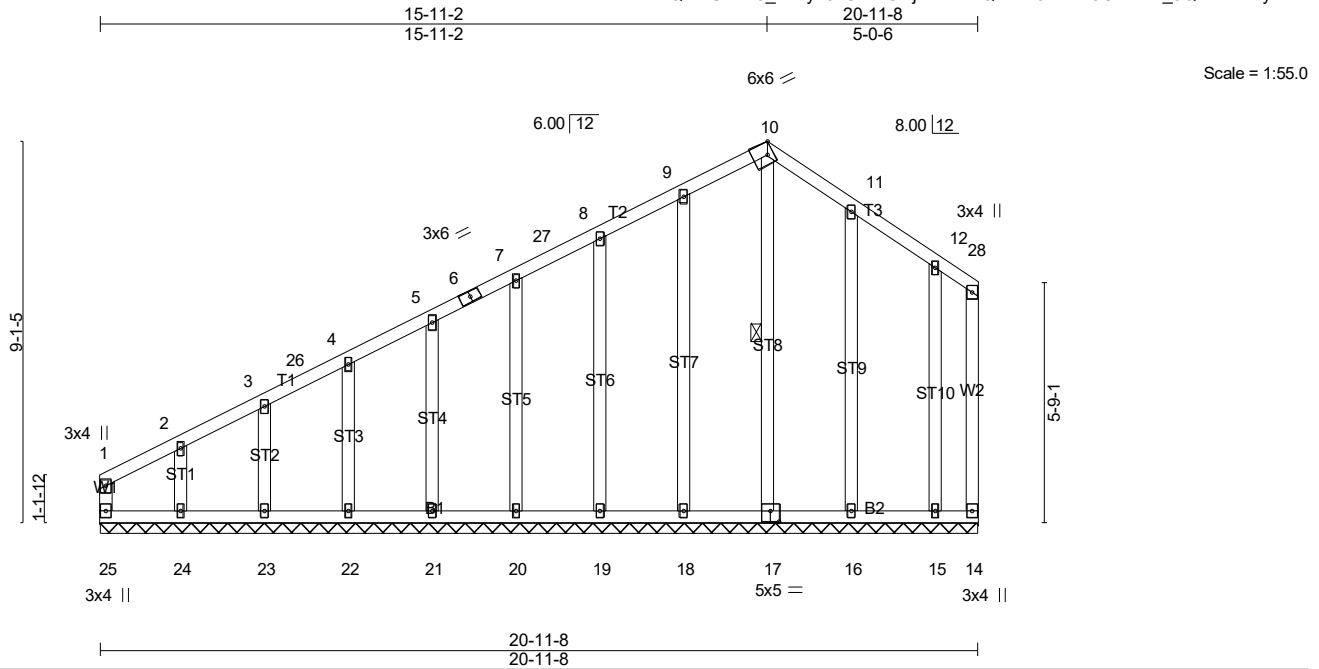

Plate Offsets (X,Y)-- [10:0-1-12,Edge], [17:0-2-8,0-3-0]

LOADING (psf)	SPACING-	CSI.	DEFL.	in (loc)	l/defl	L/d	PLATES	GRIP
TCLL (roof) 20.0	2-0-0	TC 0.27	Vert(LL)	n/a	-	n/a	MT20	244/190
Snow (Pf) 20.0	Plate Grip DOL 1.15	BC 0.28	Vert(CT)	n/a	-	n/a		
TCDL 10.0	Lumber DOL 1.15	WB 0.24	Horz(CT)	-0.00	14	n/a		
BCLL 0.0 *	Rep Stress Incr YES	Matrix-R						
BCDL 10.0	Code IRC2018/TPI2014						Weight: 156 lb	FT = 20%

**LUMBER-**  
 TOP CHORD 2x4 SP No.2  
 BOT CHORD 2x4 SP No.3  
 WEBS 2x4 SP No.3  
 OTHERS 2x4 SP No.3

**BRACING-**  
 TOP CHORD Structural wood sheathing directly applied or 6-0-0 oc purlins, except end verticals.  
 BOT CHORD Rigid ceiling directly applied or 10-0-0 oc bracing.  
 WEBS 1 Row at midpt 10-17

MiTek recommends that Stabilizers and required cross bracing be installed during truss erection, in accordance with Stabilizer Installation guide.

**REACTIONS.** All bearings 20-11-8.  
 (lb) - Max Horz 25=216(LC 14)  
 Max Uplift All uplift 100 lb or less at joint(s) 25, 14, 18, 19, 20, 21, 22, 23, 16, 15 except 24=-217(LC 14)  
 Max Grav All reactions 250 lb or less at joint(s) 25, 14, 20, 21, 22, 23, 24, 15 except 17=253(LC 30), 18=295(LC 5), 19=274(LC 5), 16=307(LC 6)

**FORCES.** (lb) - Max. Comp./Max. Ten. - All forces 250 (lb) or less except when shown.  
 TOP CHORD 1-2=-257/92

- NOTES-** (14-17)
- Unbalanced roof live loads have been considered for this design.
  - Wind: ASCE 7-16; Vult=130mph (3-second gust) Vasd=103mph; TCDL=5.0psf; BCDL=5.0psf; h=23ft; Cat. II; Exp B; Enclosed; MWFRS (envelope) gable end zone and C-C Corner(3E) 0-1-12 to 4-11-6, Exterior(2N) 4-11-6 to 11-1-9, Corner(3R) 11-1-9 to 15-11-2, Corner(3E) 15-11-2 to 20-9-12 zone; C-C for members and forces & MWFRS for reactions shown; Lumber DOL=1.60 plate grip DOL=1.60
  - Truss designed for wind loads in the plane of the truss only. For studs exposed to wind (normal to the face), see Standard Industry Gable End Details as applicable, or consult qualified building designer as per ANSI/TPI 1.
  - TCLL: ASCE 7-16; Pr=20.0 psf (roof LL: Lum DOL=1.15 Plate DOL=1.15); Pf=20.0 psf (Lum DOL=1.15 Plate DOL=1.15); Is=1.0; Rough Cat B; Partially Exp.; Ce=1.0; Cs=1.00; Ct=1.10
  - Unbalanced snow loads have been considered for this design.
  - All plates are 2x4 MT20 unless otherwise indicated.
  - Gable requires continuous bottom chord bearing.
  - Truss to be fully sheathed from one face or securely braced against lateral movement (i.e. diagonal web).
  - Gable studs spaced at 2-0-0 oc.
  - This truss has been designed for a 10.0 psf bottom chord live load nonconcurrent with any other live loads.
  - \* This truss has been designed for a live load of 30.0psf on the bottom chord in all areas where a rectangle 3-6-0 tall by 1-0-0 wide will fit between the bottom chord and any other members, with BCDL = 10.0psf.
  - Provide mechanical connection (by others) of truss to bearing plate capable of withstanding 100 lb uplift at joint(s) 25, 14, 18, 19, 20, 21, 22, 23, 16, 15 except (jt=lb) 24=217.
  - This truss is designed in accordance with the 2018 International Residential Code sections R502.11.1 and R802.10.2 and referenced standard ANSI/TPI 1.



9/29/2021

Continued on Page 2 Design parameters and read notes before use. This design is based only upon parameters shown, and is for an individual building component to be installed and loaded vertically. Applicability of design parameters and proper incorporation of component is responsibility of building designer – not truss designer or truss engineer. Bracing shown is for lateral support of individual web members only. Additional temporary bracing to ensure stability during construction is the responsibility of the erector. Additional permanent bracing of the overall structure is the responsibility of the building designer. For general guidance regarding fabrication, quality control, storage, delivery, erection and bracing, consult ANSI/TPI 1 National Design Standard for Metal Plate Connected Wood Truss Construction and BCSI 1-03 Guide to Good Practice for Handling, Installing & Bracing of Metal Plate Connected Wood Trusses from Truss Plate Institute, 583 D'Onofrio Drive, Madison, WI 53719.

Job	Truss	Truss Type	Qty	Ply	LOT 17 VILLAS @ ANDERSON CREEK   66 HAWK RIDGE DRIVE SPRING LAKE, NC
21-5120-R01	R01	GABLE	1	1	Job Reference (optional) # 28709

8.430 s Feb 12 2021 MiTek Industries, Inc. Thu Sep 30 15:45:13 2021 Page 2  
 ID:xwDXRRIPWrQwmU1uH5\_sXuyd8cO-tXqSz3\_YK9iN2HtjCoHXi6EE0slhRPa0qEgZjyYPeQ

- 14) Graphical bracing representation does not depict the size, type or the orientation of the brace on the member. Symbol only indicates that the member must be braced.
- 15) Bearing symbols are only graphical representations of a possible bearing condition. Bearing symbols are not considered in the structural design of the truss to support the loads indicated.
- 16) Web bracing shown is for lateral support of individual web members only. Refer to BCSI - Guide to Good Practice for Handling, Installing, Restraining & Bracing of Metal Plate Connected Wood Trusses for additional bracing guidelines, including diagonal bracing.
- 17) SEE BCSI-B3 SUMMARY SHEET- PERMANENT RESTRAING/BRACING OF CHORDS & WEB MEMBERS FOR RECOMMENDED MINIMUM BRACING REQUIREMENTS OF TOP CHORD, BOTTOM CHORD, AND WEB PLANES. IN ADDITION TO THESE MINIMUM GUIDELINES, ALWAYS CONSULT THE PROJECT ARCHITECT OR ENGINEER FOR ADDITIONAL BRACING CONSIDERATIONS.

**LOAD CASE(S)** Standard



9/29/2021

**Warning !—Verify design parameters and read notes before use.** This design is based only upon parameters shown, and is for an individual building component to be installed and loaded vertically. Applicability of design parameters and proper incorporation of component is responsibility of building designer – not truss designer or truss engineer. Bracing shown is for lateral support of individual web members only. Additional temporary bracing to ensure stability during construction is the responsibility of the erector. Additional permanent bracing of the overall structure is the responsibility of the building designer. For general guidance regarding fabrication, quality control, storage, delivery, erection and bracing, consult ANSI/TPI 1 *National Design Standard for Metal Plate Connected Wood Truss Construction* and BCSI 1-03 *Guide to Good Practice for Handling, Installing & Bracing of Metal Plate Connected Wood Trusses* from Truss Plate Institute, 583 D'Onofrio Drive, Madison, WI 53719.

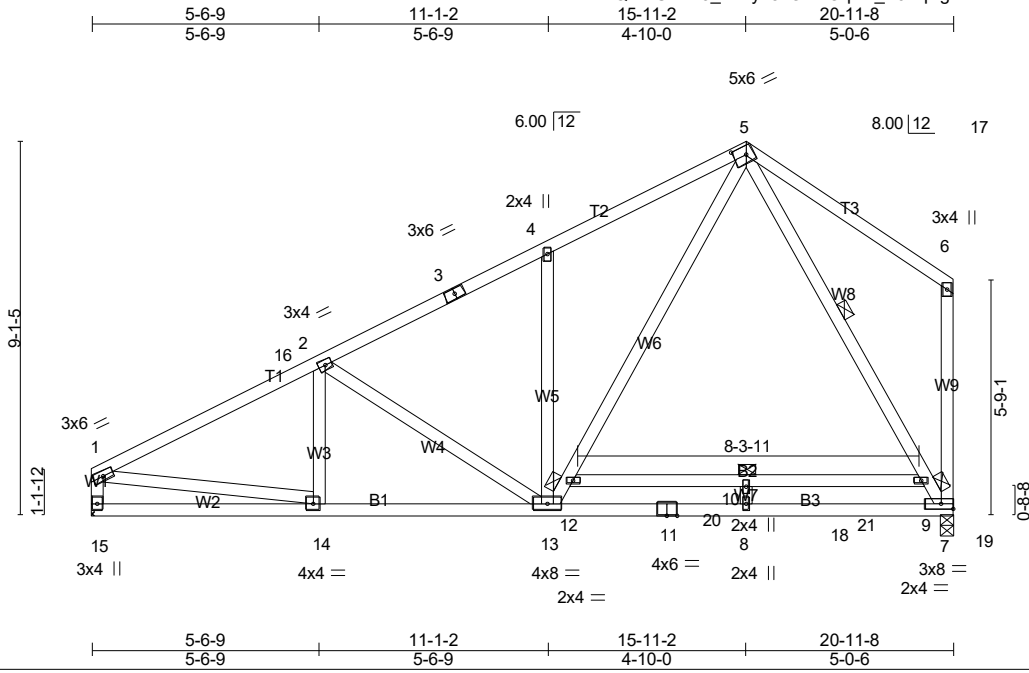

Scale = 1:56.0

**Plate Offsets (X,Y)-- [5:0-3-11,0-2-8]**

<b>LOADING</b> (psf)	<b>SPACING-</b>	<b>CSI.</b>	<b>DEFL.</b>		<b>PLATES</b>	<b>GRIP</b>
TCLL (roof) 20.0	2-0-0	TC 0.63	in (loc) l/defl L/d		MT20	244/190
Snow (Pf) 20.0	Plate Grip DOL 1.15	BC 0.90	Vert(LL) -0.50 8 >494 240			
TCDL 10.0	Lumber DOL 1.15	WB 0.71	Vert(CT) -0.75 8 >330 180			
BCLL 0.0 *	Rep Stress Incr YES	Matrix-SH	Horz(CT) 0.02 7 n/a n/a			
BCDL 10.0	Code IRC2018/TPI2014					Weight: 149 lb FT = 20%

**LUMBER-**  
 TOP CHORD 2x4 SP No.2  
 BOT CHORD 2x4 SP SS \*Except\*  
 B1: 2x4 SP No.1  
 WEBS 2x4 SP No.3 \*Except\*  
 W9: 2x4 SP No.2

**BRACING-**  
 TOP CHORD Structural wood sheathing directly applied or 4-9-10 oc purlins, except end verticals.  
 BOT CHORD Rigid ceiling directly applied or 10-0-0 oc bracing. Except: 6-0-0 oc bracing: 9-12  
 WEBS 1 Row at midpt 5-9

MiTek recommends that Stabilizers and required cross bracing be installed during truss erection, in accordance with Stabilizer Installation guide.

**REACTIONS.** (lb/size) 15=868/Mechanical, 7=961/0-3-8 (min. 0-1-8)  
 Max Horz 15=216(LC 14)  
 Max Uplift 15=-91(LC 14), 7=-73(LC 14)  
 Max Grav 15=909(LC 20), 7=1154(LC 3)

**FORCES.** (lb) - Max. Comp./Max. Ten. - All forces 250 (lb) or less except when shown.  
 TOP CHORD 1-16=-1275/155, 2-16=-1144/169, 2-3=-1111/120, 3-4=-999/143, 4-5=-1138/247, 1-15=-847/145  
 BOT CHORD 13-14=-275/1080, 11-13=-41/505, 8-11=-41/505, 8-18=-41/505, 18-19=-41/505, 7-19=-41/505  
 WEBS 2-13=-290/163, 4-13=-418/187, 12-13=-204/891, 5-12=-157/1074, 1-14=-66/951, 5-9=-783/141, 7-9=-960/93

- NOTES-** (10-13)
- 1) Unbalanced roof live loads have been considered for this design.
  - 2) Wind: ASCE 7-16; Vult=130mph (3-second gust) Vasd=103mph; TCDL=5.0psf; BCDL=5.0psf; h=23ft; Cat. II; Exp B; Enclosed; MWFRS (envelope) gable end zone and C-C Exterior(2E) 0-1-12 to 4-11-6, Interior(1) 4-11-6 to 11-1-2, Exterior(2R) 11-1-2 to 15-11-2, Exterior(2E) 15-11-2 to 20-9-12 zone; C-C for members and forces & MWFRS for reactions shown; Lumber DOL=1.60 plate grip DOL=1.60
  - 3) TCLL: ASCE 7-16; Pr=20.0 psf (roof LL: Lum DOL=1.15 Plate DOL=1.15); Pf=20.0 psf (Lum DOL=1.15 Plate DOL=1.15); Is=1.0; Rough Cat B; Partially Exp.; Ce=1.0; Cs=1.00; Ct=1.10
  - 4) Unbalanced snow loads have been considered for this design.
  - 5) This truss has been designed for a 10.0 psf bottom chord live load nonconcurrent with any other live loads.
  - 6) \* This truss has been designed for a live load of 30.0psf on the bottom chord in all areas where a rectangle 3-6-0 tall by 1-0-0 wide will fit between the bottom chord and any other members, with BCDL = 10.0psf.
  - 7) Refer to girder(s) for truss to truss connections.
  - 8) Provide mechanical connection (by others) of truss to bearing plate capable of withstanding 100 lb uplift at joint(s) 15, 7.
  - 9) This truss is designed in accordance with the 2018 International Residential Code sections R502.11.1 and R802.10.2 and referenced standard ANSI/TPI 1.

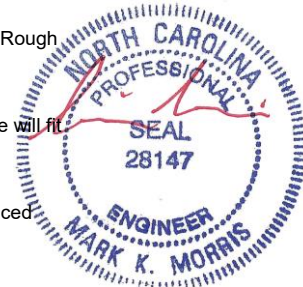

9/29/2021

Job	Truss	Truss Type	Qty	Ply	LOT 17 VILLAS @ ANDERSON CREEK   66 HAWK RIDGE DRIVE SPRING LAKE,
21-5120-R01	R02	Roof Special	6	1	Job Reference (optional) # 28709

8.430 s Feb 12 2021 MiTek Industries, Inc. Thu Sep 30 15:45:14 2021 Page 2  
 ID:xwDXRRIPWrQwmU1uH5\_sXuyd8cO-LkOqAP\_A5SqEgRSvmWomPJnK3GxGOMCjFU\_E6AyYPep

- 10) Graphical bracing representation does not depict the size, type or the orientation of the brace on the member. Symbol only indicates that the member must be braced.
- 11) Bearing symbols are only graphical representations of a possible bearing condition. Bearing symbols are not considered in the structural design of the truss to support the loads indicated.
- 12) Web bracing shown is for lateral support of individual web members only. Refer to BCSI - Guide to Good Practice for Handling, Installing, Restraining & Bracing of Metal Plate Connected Wood Trusses for additional bracing guidelines, including diagonal bracing.
- 13) SEE BCSI-B3 SUMMARY SHEET- PERMANENT RESTRAING/BRACING OF CHORDS & WEB MEMBERS FOR RECOMMENDED MINIMUM BRACING REQUIREMENTS OF TOP CHORD, BOTTOM CHORD, AND WEB PLANES. IN ADDITION TO THESE MINIMUM GUIDELINES, ALWAYS CONSULT THE PROJECT ARCHITECT OR ENGINEER FOR ADDITIONAL BRACING CONSIDERATIONS.

**LOAD CASE(S)** Standard



9/29/2021

**Warning !—Verify design parameters and read notes before use.** This design is based only upon parameters shown, and is for an individual building component to be installed and loaded vertically. Applicability of design parameters and proper incorporation of component is responsibility of building designer – not truss designer or truss engineer. Bracing shown is for lateral support of individual web members only. Additional temporary bracing to ensure stability during construction is the responsibility of the erector. Additional permanent bracing of the overall structure is the responsibility of the building designer. For general guidance regarding fabrication, quality control, storage, delivery, erection and bracing, consult ANSI/TPI 1 *National Design Standard for Metal Plate Connected Wood Truss Construction* and BCSI 1-03 *Guide to Good Practice for Handling, Installing & Bracing of Metal Plate Connected Wood Trusses* from Truss Plate Institute, 583 D\*Onofrio Drive, Madison, WI 53719.

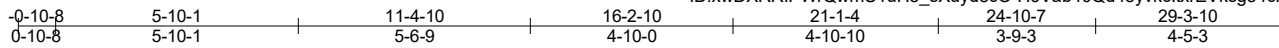

Scale = 1:55.1

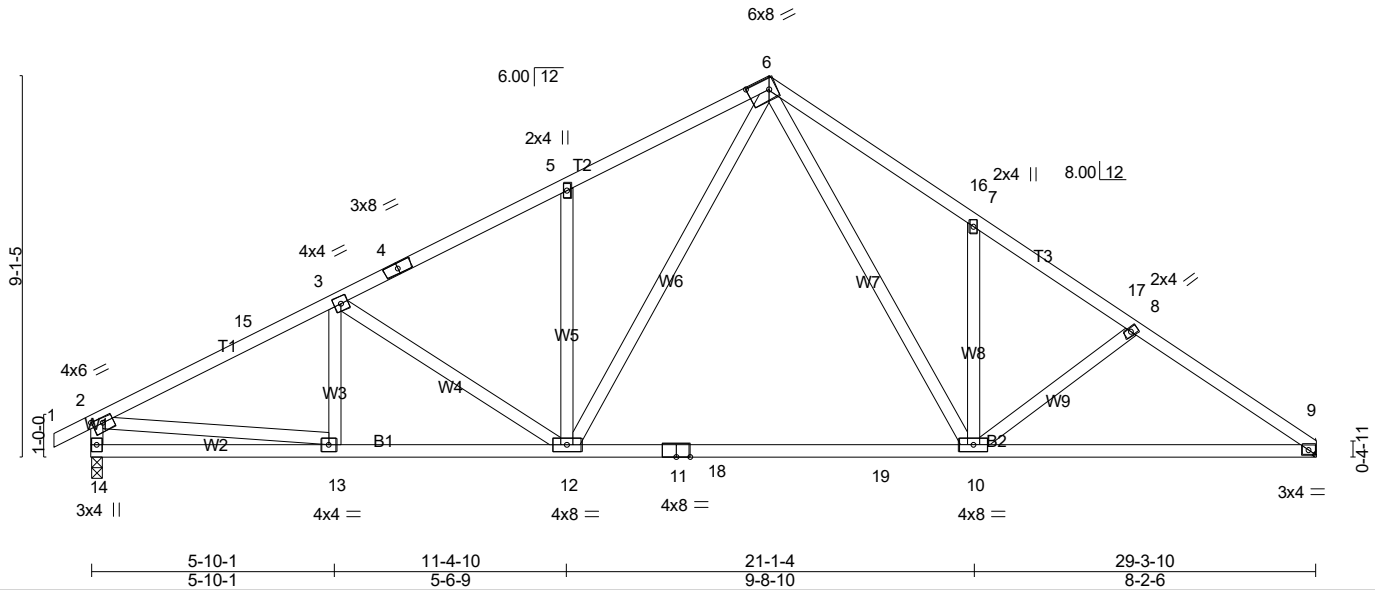

LOADING (psf)	SPACING-	CSI.	DEFL.	PLATES	GRIP
TCLL (roof) 20.0	2-0-0	TC 0.60	in (loc) l/defl L/d	MT20	244/190
Snow (Pf) 20.0	Plate Grip DOL 1.15	BC 0.93	Vert(LL) -0.50 10-12 >701 240		
TCDL 10.0	Lumber DOL 1.15	WB 0.53	Vert(CT) -0.70 10-12 >497 180		
BCLL 0.0 *	Rep Stress Incr YES	Matrix-SH	Horz(CT) 0.04 9 n/a n/a		
BCDL 10.0	Code IRC2018/TPI2014			Weight: 172 lb	FT = 20%

**LUMBER-**  
 TOP CHORD 2x4 SP No.2  
 BOT CHORD 2x4 SP No.1  
 WEBS 2x4 SP No.3

**BRACING-**  
 TOP CHORD Structural wood sheathing directly applied or 3-5-6 oc purlins, except end verticals.  
 BOT CHORD Rigid ceiling directly applied or 10-0-0 oc bracing, Except: 2-2-0 oc bracing: 10-12.

MiTek recommends that Stabilizers and required cross bracing be installed during truss erection, in accordance with Stabilizer Installation guide.

**REACTIONS.** (lb/size) 9=1163/Mechanical, 14=1226/0-3-8 (min. 0-1-8)  
 Max Horz 14=222(LC 11)  
 Max Uplift 9=-141(LC 15), 14=-186(LC 14)  
 Max Grav 9=1182(LC 25), 14=1230(LC 21)

**FORCES.** (lb) - Max. Comp./Max. Ten. - All forces 250 (lb) or less except when shown.  
 TOP CHORD 2-15=-1776/303, 3-15=-1675/316, 3-4=-1580/307, 4-5=-1509/329, 5-6=-1609/427, 6-16=-1721/464, 7-16=-1734/437, 7-17=-1579/332, 8-17=-1676/312, 8-9=-1860/346, 2-14=-1166/269  
 BOT CHORD 13-14=-219/316, 12-13=-276/1517, 12-18=-55/980, 11-18=-55/980, 11-19=-55/980, 10-19=-55/980, 9-10=-223/1469  
 WEBS 3-12=-288/142, 5-12=-421/189, 6-12=-211/857, 6-10=-218/866, 7-10=-378/199, 2-13=-134/1268

- NOTES-** (11-14)
- Unbalanced roof live loads have been considered for this design.
  - Wind: ASCE 7-16; Vult=130mph (3-second gust) Vasd=103mph; TCCL=5.0psf; BCDL=5.0psf; h=23ft; Cat. II; Exp B; Enclosed; MWFRS (envelope) gable end zone and C-C Exterior(2E) -0-10-8 to 3-11-2, Interior(1) 3-11-2 to 11-4-10, Exterior(2R) 11-4-10 to 21-1-4, Interior(1) 21-1-4 to 24-5-4, Exterior(2E) 24-5-4 to 29-2-14 zone; end vertical left exposed; C-C for members and forces & MWFRS for reactions shown; Lumber DOL=1.60 plate grip DOL=1.60
  - TCCL: ASCE 7-16; Pr=20.0 psf (roof LL: Lum DOL=1.15 Plate DOL=1.15); Pf=20.0 psf (Lum DOL=1.15 Plate DOL=1.15); Is=1.0; Rough Cat B; Partially Exp.; Ce=1.0; Cs=1.00; Ct=1.10
  - Unbalanced snow loads have been considered for this design.
  - This truss has been designed for greater of min roof live load of 12.0 psf or 2.00 times flat roof load of 20.0 psf on overhangs non-concurrent with other live loads.
  - This truss has been designed for a 10.0 psf bottom chord live load nonconcurrent with any other live loads.
  - \* This truss has been designed for a live load of 30.0psf on the bottom chord in all areas where a rectangle 3-6-0 tall by 1-0-0 wide will fit between the bottom chord and any other members, with BCDL = 10.0psf.
  - Refer to girder(s) for truss to truss connections.
  - Provide mechanical connection (by others) of truss to bearing plate capable of withstanding 100 lb uplift at joint(s) except (jt=lb) 9=141, 14=186.
  - This truss is designed in accordance with the 2018 International Residential Code sections R502.11.1 and R802.10.2 and referenced standard ANSI/TPI 1.

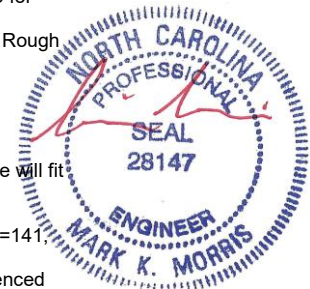

9/29/2021

Job	Truss	Truss Type	Qty	Ply	LOT 17 VILLAS @ ANDERSON CREEK   66 HAWK RIDGE DRIVE SPRING LAKE,
21-5120-R01	R03	Roof Special	3	1	Job Reference (optional) # 28709

8.430 s Feb 12 2021 MiTek Industries, Inc. Thu Sep 30 15:45:16 2021 Page 2  
 ID:xwDXRRIPWrQwmU1uH5\_sXuyd8cO-H6Vab40Qd45yvkcltrEVksg54cHsje0ioTLA2yYPen

- 11) Graphical bracing representation does not depict the size, type or the orientation of the brace on the member. Symbol only indicates that the member must be braced.
- 12) Bearing symbols are only graphical representations of a possible bearing condition. Bearing symbols are not considered in the structural design of the truss to support the loads indicated.
- 13) Web bracing shown is for lateral support of individual web members only. Refer to BCSI - Guide to Good Practice for Handling, Installing, Restraining & Bracing of Metal Plate Connected Wood Trusses for additional bracing guidelines, including diagonal bracing.
- 14) SEE BCSI-B3 SUMMARY SHEET- PERMANENT RESTRAING/BRACING OF CHORDS & WEB MEMBERS FOR RECOMMENDED MINIMUM BRACING REQUIREMENTS OF TOP CHORD, BOTTOM CHORD, AND WEB PLANES. IN ADDITION TO THESE MINIMUM GUIDELINES, ALWAYS CONSULT THE PROJECT ARCHITECT OR ENGINEER FOR ADDITIONAL BRACING CONSIDERATIONS.

**LOAD CASE(S)** Standard



9/29/2021

**Warning !—Verify design parameters and read notes before use.** This design is based only upon parameters shown, and is for an individual building component to be installed and loaded vertically. Applicability of design parameters and proper incorporation of component is responsibility of building designer – not truss designer or truss engineer. Bracing shown is for lateral support of individual web members only. Additional temporary bracing to ensure stability during construction is the responsibility of the erector. Additional permanent bracing of the overall structure is the responsibility of the building designer. For general guidance regarding fabrication, quality control, storage, delivery, erection and bracing, consult ANSI/TPI 1 *National Design Standard for Metal Plate Connected Wood Truss Construction* and BCSI 1-03 *Guide to Good Practice for Handling, Installing & Bracing of Metal Plate Connected Wood Trusses* from Truss Plate Institute, 583 D\*Onofrio Drive, Madison, WI 53719.



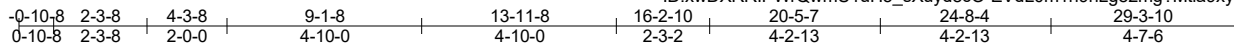

Scale = 1:57.1

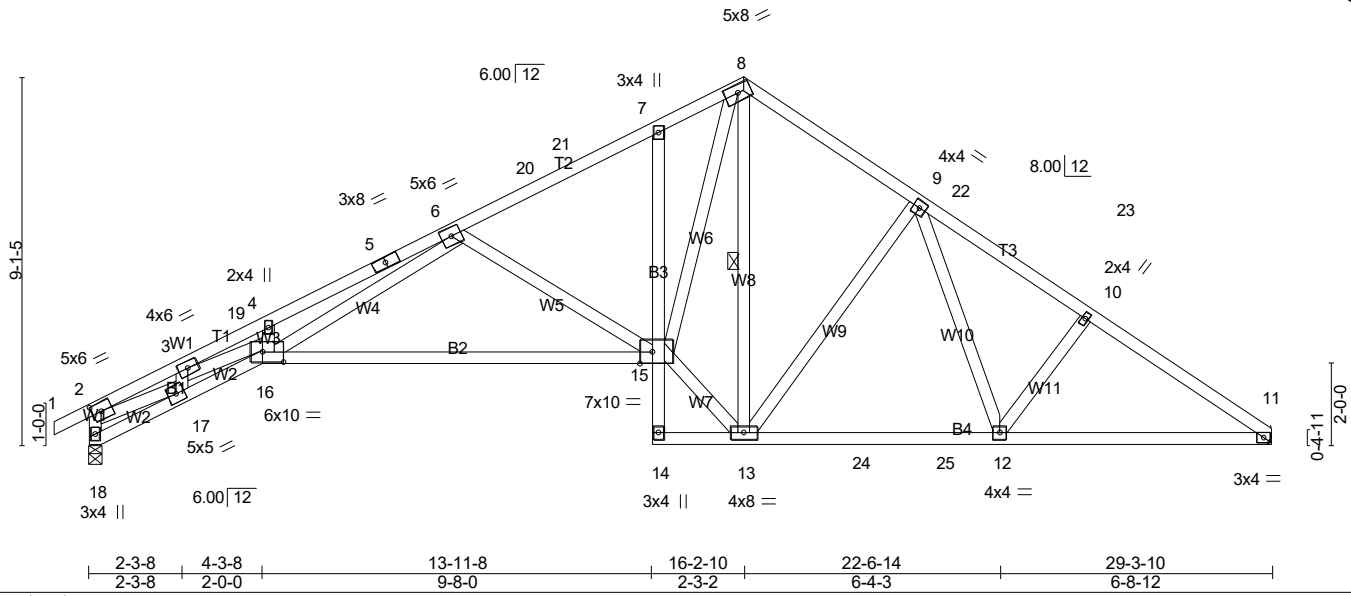

Plate Offsets (X,Y)-- [2:0-2-11,0-2-8], [15:0-3-12,Edge], [16:0-6-4,0-3-0]

LOADING (psf)	SPACING-	CSI.	DEFL.	PLATES	GRIP
TCLL (roof) 20.0	2-0-0	TC 0.85	in (loc) l/defl L/d	MT20	244/190
Snow (Pf) 20.0	Plate Grip DOL 1.15	BC 0.88	Vert(LL) -0.41 15-16 >852 240		
TCDL 10.0	Lumber DOL 1.15	WB 0.77	Vert(CT) -0.97 15-16 >362 180		
BCLL 0.0 *	Rep Stress Incr YES	Matrix-SH	Horz(CT) 0.42 11 n/a n/a		
BCDL 10.0	Code IRC2018/TPI2014			Weight: 185 lb	FT = 20%

LUMBER-	BRACING-
TOP CHORD 2x4 SP No.2 *Except* T1: 2x4 SP No.1	TOP CHORD Structural wood sheathing directly applied or 2-0-5 oc purlins, except end verticals.
BOT CHORD 2x4 SP No.2 *Except* B2: 2x4 SP No.1, B3: 2x4 SP No.3	BOT CHORD Rigid ceiling directly applied or 6-0-0 oc bracing.
WEBS 2x4 SP No.3 *Except* W2,W4: 2x4 SP No.2	WEBS 1 Row at midpt 8-13

MiTek recommends that Stabilizers and required cross bracing be installed during truss erection, in accordance with Stabilizer Installation guide.

**REACTIONS.** (lb/size) 18=1226/0-3-8 (min. 0-1-8), 11=1163/Mechanical  
 Max Horz 18=223(LC 11)  
 Max Uplift 18=-186(LC 14), 11=-141(LC 15)  
 Max Grav 18=1236(LC 21), 11=1163(LC 1)

**FORCES.** (lb) - Max. Comp./Max. Ten. - All forces 250 (lb) or less except when shown.  
 TOP CHORD 2-18=-1213/257, 2-3=-3022/565, 3-19=-5332/886, 4-19=-5286/890, 4-5=-5288/958,  
 5-6=-5191/971, 6-20=-1775/346, 20-21=-1705/347, 7-21=-1682/359, 7-8=-1706/428,  
 8-9=-1236/349, 9-22=-1531/362, 22-23=-1647/359, 10-23=-1658/338, 10-11=-1800/341  
 BOT CHORD 16-17=-645/2982, 15-16=-380/2285, 7-15=-301/135, 13-24=-135/1213, 24-25=-135/1213,  
 12-25=-135/1213, 11-12=-218/1440  
 WEBS 2-17=-457/2550, 3-17=-1008/170, 3-16=-258/2072, 6-16=-579/2948, 6-15=-918/297,  
 13-15=-26/1349, 8-15=-275/1858, 8-13=-564/84, 9-13=-501/197, 9-12=-63/411

- NOTES-** (12-15)
- Unbalanced roof live loads have been considered for this design.
  - Wind: ASCE 7-16; Vult=130mph (3-second gust) Vasd=103mph; TCCL=5.0psf; BCDL=5.0psf; h=23ft; Cat. II; Exp B; Enclosed; MWFRS (envelope) gable end zone and C-C Exterior(2E) -0-10-8 to 3-11-2, Interior(1) 3-11-2 to 11-5-0, Exterior(2R) 11-5-0 to 21-0-3, Interior(1) 21-0-3 to 24-5-4, Exterior(2E) 24-5-4 to 29-2-14 zone; end vertical left exposed; C-C for members and forces & MWFRS for reactions shown; Lumber DOL=1.60 plate grip DOL=1.60
  - TCCL: ASCE 7-16; Pr=20.0 psf (roof LL: Lum DOL=1.15 Plate DOL=1.15); Pf=20.0 psf (Lum DOL=1.15 Plate DOL=1.15); Is=1.0; Rough Cat B; Partially Exp.; Ce=1.0; Cs=1.00; Ct=1.10
  - Unbalanced snow loads have been considered for this design.
  - This truss has been designed for greater of min roof live load of 12.0 psf or 2.00 times flat roof load of 20.0 psf on overhangs non-concurrent with other live loads.
  - This truss has been designed for a 10.0 psf bottom chord live load nonconcurrent with any other live loads.
  - \* This truss has been designed for a live load of 30.0psf on the bottom chord in all areas where a rectangle 3-6-0 tall by 1-0-0 wide will fit between the bottom chord and any other members, with BCDL = 10.0psf.
  - Refer to girder(s) for truss to truss connections.
  - Bearing at joint(s) 18 considers parallel to grain value using ANSI/TPI 1 angle to grain formula. Building designer should verify capacity of bearing surface.
  - Provide mechanical connection (by others) of truss to bearing plate capable of withstanding 100 lb uplift at joint(s) except (jt=lb) 18=186, 11=141.
  - This truss is designed in accordance with the 2018 International Residential Code sections R502.11.1 and R802.10.2 and referenced standard ANSI/TPI 1.

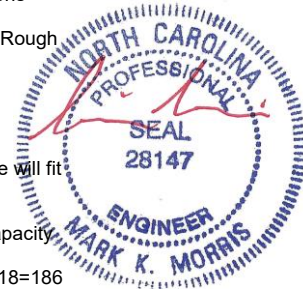

Continued on page 2. Design parameters and read notes before use. This design is based only upon parameters shown, and is for an individual building component to be installed and loaded vertically. Applicability of design parameters and proper incorporation of component is responsibility of building designer – not truss designer or truss engineer. Bracing shown is for lateral support of individual web members only. Additional temporary bracing to ensure stability during construction is the responsibility of the erector. Additional permanent bracing of the overall structure is the responsibility of the building designer. For general guidance regarding fabrication, quality control, storage, delivery, erection and bracing, consult ANSI/TPI 1 National Design Standard for Metal Plate Connected Wood Truss Construction and BCSI 1-03 Guide to Good Practice for Handling, Installing & Bracing of Metal Plate Connected Wood Trusses from Truss Plate Institute, 583 D'Onofrio Drive, Madison, WI 53719.

Job	Truss	Truss Type	Qty	Ply	LOT 17 VILLAS @ ANDERSON CREEK   66 HAWK RIDGE DRIVE SPRING LAKE, NC
21-5120-R01	R04	Roof Special	1	1	Job Reference (optional) # 28709

8.430 s Feb 12 2021 MiTek Industries, Inc. Thu Sep 30 15:45:18 2021 Page 2

ID:xwDXRRIPWrQwmU1uH5\_sXuyd8cO-EVdL0m1h9hLg82mg?Mtia9xyctJQKZJJA6yRFxyYPel

- 12) Graphical bracing representation does not depict the size, type or the orientation of the brace on the member. Symbol only indicates that the member must be braced.
- 13) Bearing symbols are only graphical representations of a possible bearing condition. Bearing symbols are not considered in the structural design of the truss to support the loads indicated.
- 14) Web bracing shown is for lateral support of individual web members only. Refer to BCSI - Guide to Good Practice for Handling, Installing, Restraining & Bracing of Metal Plate Connected Wood Trusses for additional bracing guidelines, including diagonal bracing.
- 15) SEE BCSI-B3 SUMMARY SHEET- PERMANENT RESTRAING/BRACING OF CHORDS & WEB MEMBERS FOR RECOMMENDED MINIMUM BRACING REQUIREMENTS OF TOP CHORD, BOTTOM CHORD, AND WEB PLANES. IN ADDITION TO THESE MINIMUM GUIDELINES, ALWAYS CONSULT THE PROJECT ARCHITECT OR ENGINEER FOR ADDITIONAL BRACING CONSIDERATIONS.

**LOAD CASE(S)** Standard



9/29/2021

**Warning !—Verify design parameters and read notes before use.** This design is based only upon parameters shown, and is for an individual building component to be installed and loaded vertically. Applicability of design parameters and proper incorporation of component is responsibility of building designer – not truss designer or truss engineer. Bracing shown is for lateral support of individual web members only. Additional temporary bracing to ensure stability during construction is the responsibility of the erector. Additional permanent bracing of the overall structure is the responsibility of the building designer. For general guidance regarding fabrication, quality control, storage, delivery, erection and bracing, consult ANSI/TPI 1 *National Design Standard for Metal Plate Connected Wood Truss Construction* and BCSI 1-03 *Guide to Good Practice for Handling, Installing & Bracing of Metal Plate Connected Wood Trusses* from Truss Plate Institute, 583 D'Onofrio Drive, Madison, WI 53719.

Job 21-5120-R01	Truss R05	Truss Type ROOF SPECIAL	Qty 2	Ply 2	LOT 17 VILLAS @ ANDERSON CREEK   66 HAWK RIDGE DRIVE SPRING LAKE, NC	Job Reference (optional) # 28709
--------------------	--------------	----------------------------	----------	----------	--	-------------------------------------

8.430 s Feb 12 2021 MiTek Industries, Inc. Thu Sep 30 15:45:20 2021 Page 1  
ID:xwDXRRIPWwQwmU1uH5\_sXuyd8cO-Aul5RS3xhBOOMv36mvAfa1Hhh\_OoSfcdQRYJqyYpej

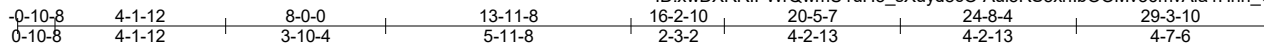

Scale = 1:55.7

Plate Offsets (X,Y)-- [13:0-3-4,0-3-0]											
<b>LOADING</b> (psf)		<b>SPACING-</b>	4-4-0	<b>CSI.</b>		<b>DEFL.</b>	in (loc)	l/defl	L/d	<b>PLATES</b>	<b>GRIP</b>
TCLL (roof)	20.0	Plate Grip DOL	1.15	TC	0.94	Vert(LL)	-0.16 13-14	>999	240	MT20	244/190
Snow (Pf)	20.0	Lumber DOL	1.15	BC	0.92	Vert(CT)	-0.33 13-14	>999	180		
TCDL	10.0	Rep Stress Incr	NO	WB	0.84	Horz(CT)	0.14 9	n/a	n/a		
BCLL	0.0 *	Code IRC2018/TPI2014		Matrix-SH							
BCDL	10.0									Weight: 367 lb	FT = 20%

**LUMBER-**  
TOP CHORD 2x4 SP No.2  
BOT CHORD 2x4 SP No.2 \*Except\*  
B2: 2x4 SP No.3  
WEBS 2x4 SP No.3

**BRACING-**  
TOP CHORD 2-0-0 oc purlins (3-11-4 max.), except end verticals  
(Switched from sheeted: Spacing > 2-0-0).  
BOT CHORD Rigid ceiling directly applied or 10-0-0 oc bracing, Except:  
6-0-0 oc bracing: 12-13.

**REACTIONS.** (lb/size) 9=2519/Mechanical, 15=2656/0-3-8 (min. 0-1-9)  
Max Horz 15=427(LC 13)  
Max Uplift 9=328(LC 15), 15=418(LC 14)  
Max Grav 9=2519(LC 1), 15=2676(LC 21)

**FORCES.** (lb) - Max. Comp./Max. Ten. - All forces 250 (lb) or less except when shown.  
TOP CHORD 2-3=-603/114, 3-4=-5728/1245, 4-16=-3835/961, 5-16=-3633/992, 5-6=-3767/1194,  
6-7=-2679/917, 7-17=-3287/978, 17-18=-3568/973, 8-18=-3592/927, 8-9=-3900/934,  
2-15=-648/261  
BOT CHORD 14-15=-857/4846, 13-14=-868/5516, 5-13=-962/434, 11-19=-408/2630, 19-20=-408/2630,  
10-20=-408/2630, 9-10=-624/3120  
WEBS 3-14=-1/939, 4-14=-43/370, 4-13=-2450/540, 11-13=-149/2787, 6-13=-747/4072,  
6-11=-1141/172, 7-11=-1107/457, 7-10=-135/889, 8-10=-472/324, 3-15=-4747/1126

**NOTES-** (13-16)

- 2-ply truss to be connected together with 10d (0.131"x3") nails as follows:  
Top chords connected as follows: 2x4 - 1 row at 0-9-0 oc.  
Bottom chords connected as follows: 2x4 - 1 row at 0-9-0 oc.  
Webs connected as follows: 2x4 - 1 row at 0-9-0 oc.
- All loads are considered equally applied to all plies, except if noted as front (F) or back (B) face in the LOAD CASE(S) section. Ply to ply connections have been provided to distribute only loads noted as (F) or (B), unless otherwise indicated.
- Unbalanced roof live loads have been considered for this design.
- Wind: ASCE 7-16; Vult=130mph (3-second gust) Vasd=103mph; TCCL=5.0psf; BCDL=5.0psf; h=23ft; Cat. II; Exp B; Enclosed; MWFRS (envelope) gable end zone and C-C Exterior(2E) -0-10-8 to 3-11-0, Interior(1) 3-11-0 to 11-5-0, Exterior(2R) 11-5-0 to 21-0-3, Interior(1) 21-0-3 to 24-5-4, Exterior(2E) 24-5-4 to 29-2-14 zone; end vertical left exposed; C-C for members and forces & MWFRS for reactions shown; Lumber DOL=1.60 plate grip DOL=1.60
- TCCL: ASCE 7-16; Pr=20.0 psf (roof LL: Lum DOL=1.15 Plate DOL=1.15); Pf=20.0 psf (Lum DOL=1.15 Plate DOL=1.15); Is=1.0; Rough; Cat B; Partially Exp.; Ce=1.0; Cs=1.00; Ct=1.10
- Unbalanced snow loads have been considered for this design.
- This truss has been designed for greater of min roof live load of 12.0 psf or 2.00 times flat roof load of 20.0 psf on overhangs non-concurrent with other live loads.
- This truss has been designed for a 10.0 psf bottom chord live load nonconcurrent with any other live loads.
- \* This truss has been designed for a live load of 30.0psf on the bottom chord in all areas where a rectangle 3-6-0 tall by 1-0-0 wide will fit between the bottom chord and any other members, with BCDL = 10.0psf.
- Refer to girder(s) for truss to truss connections.
- Provide mechanical connection (by others) of truss to bearing plate capable of withstanding 100 lb uplift at joint(s) except (jt=lb) 9=328, 15=418.



9/29/2021

Continued on Page 2 Design parameters and read notes before use. This design is based only upon parameters shown, and is for an individual building component to be installed and loaded vertically. Applicability of design parameters and proper incorporation of component is responsibility of building designer – not truss designer or truss engineer. Bracing shown is for lateral support of individual web members only. Additional temporary bracing to ensure stability during construction is the responsibility of the erector. Additional permanent bracing of the overall structure is the responsibility of the building designer. For general guidance regarding fabrication, quality control, storage, delivery, erection and bracing, consult ANSI/TPI 1 National Design Standard for Metal Plate Connected Wood Truss Construction and BCSI 1-03 Guide to Good Practice for Handling, Installing & Bracing of Metal Plate Connected Wood Trusses from Truss Plate Institute, 583 D'Onofrio Drive, Madison, WI 53719.

Job 21-5120-R01	Truss R05	Truss Type ROOF SPECIAL	Qty 2	Ply 2	LOT 17 VILLAS @ ANDERSON CREEK   66 HAWK RIDGE DRIVE SPRING LAKE, NC Job Reference (optional) # 28709
--------------------	--------------	----------------------------	----------	----------	--

8.430 s Feb 12 2021 MiTek Industries, Inc. Thu Sep 30 15:45:21 2021 Page 2  
ID:xwDXRRIPWrQwmU1uH5\_sXuyd8cO-e4JTeo4ZScjE?VUFgUQPCoZRR5JdXvvlS4A6sGyYPei

**NOTES-** (13-16)

- 12) This truss is designed in accordance with the 2018 International Residential Code sections R502.11.1 and R802.10.2 and referenced standard ANSI/TPI 1.
- 13) Graphical bracing representation does not depict the size, type or the orientation of the brace on the member. Symbol only indicates that the member must be braced.
- 14) Bearing symbols are only graphical representations of a possible bearing condition. Bearing symbols are not considered in the structural design of the truss to support the loads indicated.
- 15) Web bracing shown is for lateral support of individual web members only. Refer to BCSI - Guide to Good Practice for Handling, Installing, Restraining & Bracing of Metal Plate Connected Wood Trusses for additional bracing guidelines, including diagonal bracing.
- 16) SEE BCSI-B3 SUMMARY SHEET- PERMANENT RESTRAING/BRACING OF CHORDS & WEB MEMBERS FOR RECOMMENDED MINIMUM BRACING REQUIREMENTS OF TOP CHORD, BOTTOM CHORD, AND WEB PLANES. IN ADDITION TO THESE MINIMUM GUIDELINES, ALWAYS CONSULT THE PROJECT ARCHITECT OR ENGINEER FOR ADDITIONAL BRACING CONSIDERATIONS.

**LOAD CASE(S)** Standard



9/29/2021

**Warning !—Verify design parameters and read notes before use.** This design is based only upon parameters shown, and is for an individual building component to be installed and loaded vertically. Applicability of design parameters and proper incorporation of component is responsibility of building designer – not truss designer or truss engineer. Bracing shown is for lateral support of individual web members only. Additional temporary bracing to ensure stability during construction is the responsibility of the erector. Additional permanent bracing of the overall structure is the responsibility of the building designer. For general guidance regarding fabrication, quality control, storage, delivery, erection and bracing, consult ANSI/TPI 1 *National Design Standard for Metal Plate Connected Wood Truss Construction* and BCSI 1-03 *Guide to Good Practice for Handling, Installing & Bracing of Metal Plate Connected Wood Trusses* from Truss Plate Institute, 583 D'Onofrio Drive, Madison, WI 53719.

Job	Truss	Truss Type	Qty	Ply	LOT 17 VILLAS @ ANDERSON CREEK   66 HAWK RIDGE DRIVE SPRING LAKE, NC
21-5120-R01	R06	GABLE	1	1	# 28709

8.430 s Feb 12 2021 MiTek Industries, Inc. Thu Sep 30 15:45:23 2021 Page 1

ID:xwDXRRIPWqWmU1uH5\_sXuyd8cO-aTRE3U5p\_DzyFpeeovTtHdfy4uBc?z\_2JOfCw8yYPeg

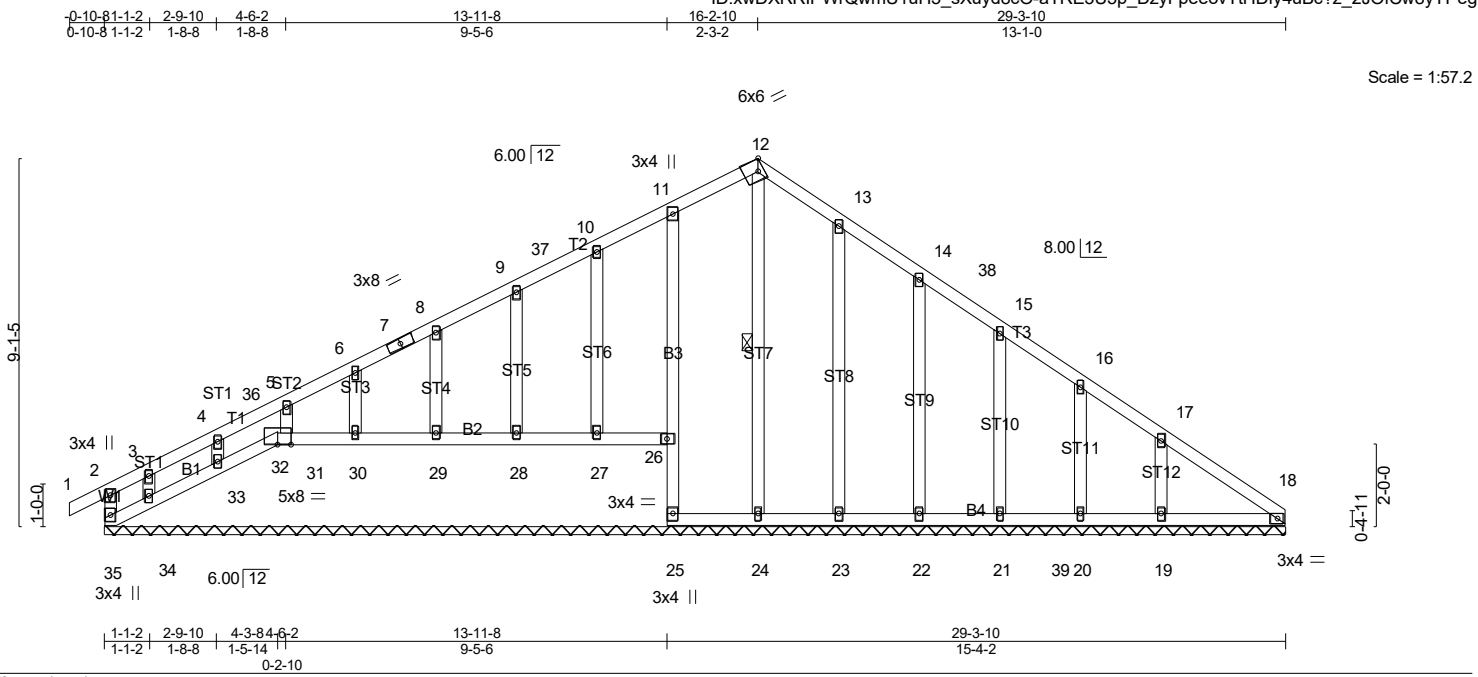

Scale = 1:57.2

Plate Offsets (X,Y)-- [12:0-1-12,Edge]

LOADING (psf)	SPACING-	CSI.	DEFL.	in (loc)	l/defl	L/d	PLATES	GRIP
TCLL (roof) 20.0	2-0-0	TC 0.23	Vert(LL) 0.00	1	n/r	180	MT20	244/190
Snow (Pf) 20.0	Plate Grip DOL 1.15	BC 0.18	Vert(CT) -0.00	1	n/r	80		
TCDL 10.0	Lumber DOL 1.15	WB 0.23	Horz(CT) 0.02	18	n/a	n/a		
BCLL 0.0 *	Rep Stress Incr YES	Matrix-SH						
BCDL 10.0	Code IRC2018/TPI2014							
							Weight: 177 lb	FT = 20%

**LUMBER-**  
 TOP CHORD 2x4 SP No.2  
 BOT CHORD 2x4 SP No.3  
 WEBS 2x4 SP No.3  
 OTHERS 2x4 SP No.3

**BRACING-**  
 TOP CHORD Structural wood sheathing directly applied or 6-0-0 oc purlins, except end verticals.  
 BOT CHORD Rigid ceiling directly applied or 6-0-0 oc bracing, Except: 10-0-0 oc bracing: 25-26.  
 WEBS 1 Row at midpt 12-24

MiTek recommends that Stabilizers and required cross bracing be installed during truss erection, in accordance with Stabilizer Installation guide.

**REACTIONS.** All bearings 29-3-10.  
 (lb) - Max Horz 35=223(LC 11)  
 Max Uplift All uplift 100 lb or less at joint(s) 18, 32, 26, 25, 27, 28, 29, 30, 23, 22, 21, 20, 31, 33 except 35=189(LC 15), 19=101(LC 15), 34=214(LC 11)  
 Max Grav All reactions 250 lb or less at joint(s) 18, 32, 26, 25, 28, 29, 30, 20, 31, 33, 34 except 35=302(LC 13), 24=357(LC 27), 27=282(LC 5), 23=297(LC 6), 22=268(LC 6), 21=269(LC 25), 19=263(LC 25)

**FORCES.** (lb) - Max. Comp./Max. Ten. - All forces 250 (lb) or less except when shown.  
 TOP CHORD 8-9=-145/269, 9-37=-132/307, 10-37=-115/312, 10-11=-127/358, 11-12=-145/399, 12-13=-154/423, 13-14=-129/368, 14-38=-92/300, 15-38=-102/290  
 WEBS 12-24=-335/88

- NOTES-** (16-19)
- Unbalanced roof live loads have been considered for this design.
  - Wind: ASCE 7-16; Vult=130mph (3-second gust) Vasd=103mph; TCCL=5.0psf; BCDL=5.0psf; h=23ft; Cat. II; Exp B; Enclosed; MWFRS (envelope) gable end zone and C-C Corner(3E) -0-10-8 to 3-11-2, Exterior(2N) 3-11-2 to 11-5-1, Corner(3R) 11-5-1 to 21-0-4, Exterior(2N) 21-0-4 to 24-2-10, Corner(3E) 24-2-10 to 29-3-10 zone; end vertical left exposed; C-C for members and forces & MWFRS for reactions shown; Lumber DOL=1.60 plate grip DOL=1.60
  - Truss designed for wind loads in the plane of the truss only. For studs exposed to wind (normal to the face), see Standard Industry Gable End Details as applicable, or consult qualified building designer as per ANSI/TPI 1.
  - TCCL: ASCE 7-16; Pr=20.0 psf (roof LL: Lum DOL=1.15 Plate DOL=1.15); Pf=20.0 psf (Lum DOL=1.15 Plate DOL=1.15); Is=1.0; Rough Cat B; Partially Exp.; Ce=1.0; Cs=1.00; Ct=1.10
  - Unbalanced snow loads have been considered for this design.
  - This truss has been designed for greater of min roof live load of 12.0 psf or 2.00 times flat roof load of 20.0 psf on overhangs non-concurrent with other live loads.
  - All plates are 2x4 MT20 unless otherwise indicated.
  - Gable requires continuous bottom chord bearing.
  - Gable studs spaced at 2-0-0 oc.
  - This truss has been designed for a 10.0 psf bottom chord live load nonconcurrent with any other live loads.
  - \* This truss has been designed for a live load of 30.0psf on the bottom chord in all areas where a rectangle 3-6-0 tall by 1-0-0 wide will fit between the bottom chord and any other members, with BCDL = 10.0psf.
  - Bearing at joint(s) 26 considers parallel to grain value using ANSI/TPI 1 angle to grain formula. Building designer should verify capacity of bearing surface.

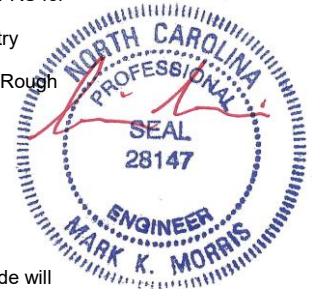

9/29/2021

Continued on page 2. Design parameters and read notes before use. This design is based only upon parameters shown, and is for an individual building component to be installed and loaded vertically. Applicability of design parameters and proper incorporation of component is responsibility of building designer – not truss designer or truss engineer. Bracing shown is for lateral support of individual web members only. Additional temporary bracing to ensure stability during construction is the responsibility of the erector. Additional permanent bracing of the overall structure is the responsibility of the building designer. For general guidance regarding fabrication, quality control, storage, delivery, erection and bracing, consult ANSI/TPI 1 National Design Standard for Metal Plate Connected Wood Truss Construction and BCSI 1-03 Guide to Good Practice for Handling, Installing & Bracing of Metal Plate Connected Wood Trusses from Truss Plate Institute, 583 D'Onofrio Drive, Madison, WI 53719.

Job	Truss	Truss Type	Qty	Ply	LOT 17 VILLAS @ ANDERSON CREEK   66 HAWK RIDGE DRIVE SPRING LAKE, NC
21-5120-R01	R06	GABLE	1	1	Job Reference (optional) # 28709

8.430 s Feb 12 2021 MiTek Industries, Inc. Thu Sep 30 15:45:24 2021 Page 2  
 ID:xwDXRRIPWrQwmU1uH5\_sXuyd8cO-2f\_chp6RIX5pszdQlC\_6pQB7qIXrkQEBY2PmSbyYPef

**NOTES-** (16-19)

- 13) Provide mechanical connection (by others) of truss to bearing plate capable of withstanding 100 lb uplift at joint(s) 18, 32, 26, 25, 27, 28, 29, 30, 23, 22, 21, 20, 31, 33 except (jt=lb) 35=189, 19=101, 34=214.
- 14) Beveled plate or shim required to provide full bearing surface with truss chord at joint(s) 32, 27, 28, 29, 30, 31, 33, 34.
- 15) This truss is designed in accordance with the 2018 International Residential Code sections R502.11.1 and R802.10.2 and referenced standard ANSI/TPI 1.
- 16) Graphical bracing representation does not depict the size, type or the orientation of the brace on the member. Symbol only indicates that the member must be braced.
- 17) Bearing symbols are only graphical representations of a possible bearing condition. Bearing symbols are not considered in the structural design of the truss to support the loads indicated.
- 18) Web bracing shown is for lateral support of individual web members only. Refer to BCSI - Guide to Good Practice for Handling, Installing, Restraining & Bracing of Metal Plate Connected Wood Trusses for additional bracing guidelines, including diagonal bracing.
- 19) SEE BCSI-B3 SUMMARY SHEET- PERMANENT RESTRAING/BRACING OF CHORDS & WEB MEMBERS FOR RECOMMENDED MINIMUM BRACING REQUIREMENTS OF TOP CHORD, BOTTOM CHORD, AND WEB PLANES. IN ADDITION TO THESE MINIMUM GUIDELINES, ALWAYS CONSULT THE PROJECT ARCHITECT OR ENGINEER FOR ADDITIONAL BRACING CONSIDERATIONS.

**LOAD CASE(S)** Standard



9/29/2021

**Warning !—Verify design parameters and read notes before use.** This design is based only upon parameters shown, and is for an individual building component to be installed and loaded vertically. Applicability of design parameters and proper incorporation of component is responsibility of building designer – not truss designer or truss engineer. Bracing shown is for lateral support of individual web members only. Additional temporary bracing to ensure stability during construction is the responsibility of the erector. Additional permanent bracing of the overall structure is the responsibility of the building designer. For general guidance regarding fabrication, quality control, storage, delivery, erection and bracing, consult ANSI/TPI 1 *National Design Standard for Metal Plate Connected Wood Truss Construction* and BCSI 1-03 *Guide to Good Practice for Handling, Installing & Bracing of Metal Plate Connected Wood Trusses* from Truss Plate Institute, 583 D'Onofrio Drive, Madison, WI 53719.

Job 21-5120-R01	Truss R07	Truss Type GABLE	Qty 1	Ply 1	LOT 17 VILLAS @ ANDERSON CREEK   66 HAWK RIDGE DRIVE SPRING LAKE, Job Reference (optional) <b># 28709</b>
--------------------	--------------	---------------------	----------	----------	--

8.430 s Feb 12 2021 MiTek Industries, Inc. Thu Sep 30 15:45:26 2021 Page 1  
ID:xwDXRRIPWwQwmU1uH5\_sXuyd8cO-?26MhV8iH8LX6HNDT10avrHP15ANCKDU?MusXTyYPed

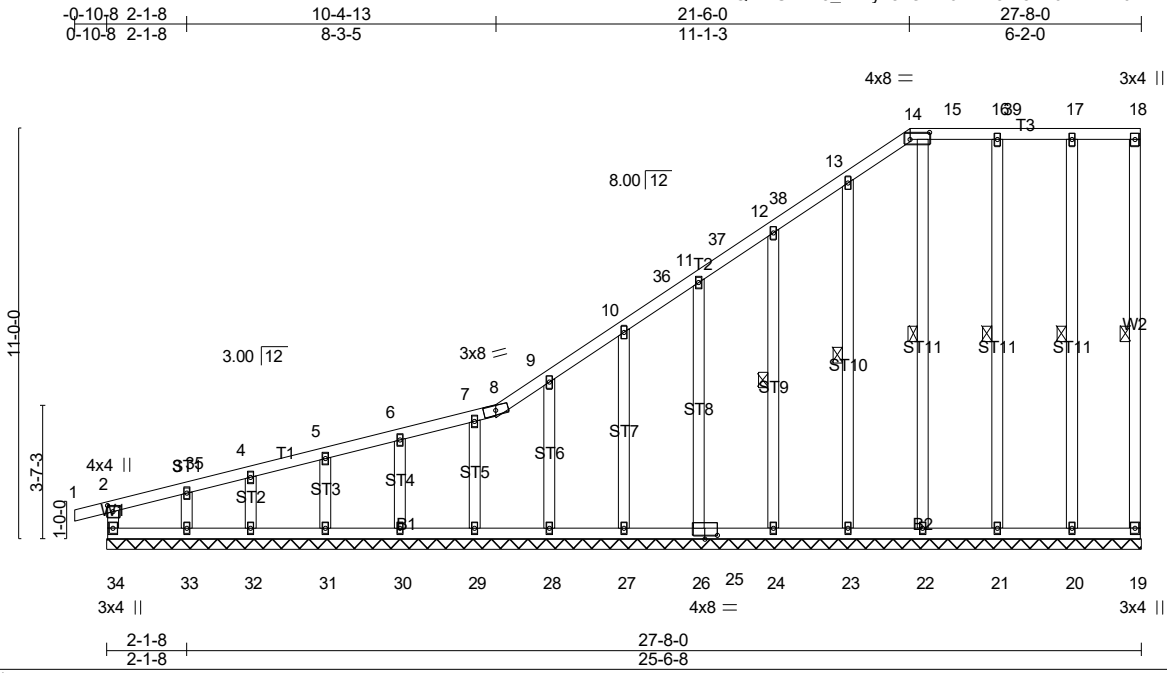

Scale = 1:61.7

Plate Offsets (X,Y)-- [2:0-2-0,0-1-12], [14:0-6-4,0-2-4], [25:0-4-0,0-1-4]

<b>LOADING</b> (psf)		<b>SPACING-</b>	2-0-0	<b>CSI.</b>		<b>DEFL.</b>	in (loc)	l/defl	L/d	<b>PLATES</b>	<b>GRIP</b>	
TCLL (roof)	20.0	Plate Grip DOL	1.15	TC	0.50	Vert(LL)	-0.00	1	n/r	180	MT20	244/190
Snow (Pf)	20.0	Lumber DOL	1.15	BC	0.37	Vert(CT)	-0.00	1	n/r	80		
TCDL	10.0	Rep Stress Incr	YES	WB	0.20	Horz(CT)	-0.00	19	n/a	n/a		
BCLL	0.0 *	Code IRC2018/TPI2014		Matrix-R								
BCDL	10.0											Weight: 214 lb FT = 20%

**LUMBER-**  
TOP CHORD 2x4 SP No.2  
BOT CHORD 2x4 SP No.3  
WEBS 2x4 SP No.3  
OTHERS 2x4 SP No.3

**BRACING-**  
TOP CHORD Structural wood sheathing directly applied or 6-0-0 oc purlins, except end verticals.  
BOT CHORD Rigid ceiling directly applied or 10-0-0 oc bracing.  
WEBS 1 Row at midpt 18-19, 12-24, 13-23, 15-22, 16-21, 17-20

MiTek recommends that Stabilizers and required cross bracing be installed during truss erection, in accordance with Stabilizer Installation guide.

**REACTIONS.** All bearings 27-8-0.  
(lb) - Max Horz 34=356(LC 14)  
Max Uplift All uplift 100 lb or less at joint(s) 34, 19, 27, 28, 29, 30, 31, 32, 26, 24, 23, 22, 21, 20 except 33=-253(LC 14)  
Max Grav All reactions 250 lb or less at joint(s) 34, 19, 29, 30, 31, 32, 33 except 27=338(LC 48), 28=276(LC 48), 26=320(LC 48), 24=331(LC 48), 23=333(LC 48), 22=259(LC 45), 21=311(LC 45), 20=300(LC 45)

**FORCES.** (lb) - Max. Comp./Max. Ten. - All forces 250 (lb) or less except when shown.  
TOP CHORD 2-3=-445/178, 3-35=-392/150, 4-35=-391/154, 4-5=-386/151, 5-6=-368/142, 6-7=-346/132, 7-8=-355/130, 8-9=-361/138, 9-10=-333/121, 10-36=-276/83, 11-36=-266/99

- NOTES-** (15-18)
- 1) Wind: ASCE 7-16; Vult=130mph (3-second gust) Vasd=103mph; TCCL=5.0psf; BCDL=5.0psf; h=23ft; Cat. II; Exp B; Enclosed; MWFRS (envelope) gable end zone and C-C Corner(3E) -0-10-8 to 3-10-0, Exterior(2N) 3-10-0 to 16-8-6, Corner(3R) 16-8-6 to 22-8-10, Corner(3E) 22-8-10 to 27-6-4 zone; end vertical left exposed; C-C for members and forces & MWFRS for reactions shown; Lumber DOL=1.60 plate grip DOL=1.60
  - 2) Truss designed for wind loads in the plane of the truss only. For studs exposed to wind (normal to the face), see Standard Industry Gable End Details as applicable, or consult qualified building designer as per ANSI/TPI 1.
  - 3) TCCL: ASCE 7-16; Pr=20.0 psf (roof LL: Lum DOL=1.15 Plate DOL=1.15); PF=20.0 psf (Lum DOL=1.15 Plate DOL=1.15); Is=1.0; Rough Cat B; Partially Exp.; Ce=1.0; Cs=1.00; Ct=1.10
  - 4) Unbalanced snow loads have been considered for this design.
  - 5) This truss has been designed for greater of min roof live load of 12.0 psf or 2.00 times flat roof load of 20.0 psf on overhangs non-concurrent with other live loads.
  - 6) Provide adequate drainage to prevent water ponding.
  - 7) All plates are 2x4 MT20 unless otherwise indicated.
  - 8) Gable requires continuous bottom chord bearing.
  - 9) Truss to be fully sheathed from one face or securely braced against lateral movement (i.e. diagonal web).
  - 10) Gable studs spaced at 2-0-0 oc.
  - 11) This truss has been designed for a 10.0 psf bottom chord live load nonconcurrent with any other live loads.
  - 12) \* This truss has been designed for a live load of 30.0psf on the bottom chord in all areas where a rectangle 3-6-0 tall by 1-0-0 wide will fit between the bottom chord and any other members, with BCDL = 10.0psf.
  - 13) Provide mechanical connection (by others) of truss to bearing plate capable of withstanding 100 lb uplift at joint(s) 34, 19, 27, 28, 29, 30, 31, 32, 26, 24, 23, 22, 21, 20 except (jt=lb) 33=253.



9/29/2021

Continued on page 2 Design parameters and read notes before use. This design is based only upon parameters shown, and is for an individual building component to be installed and loaded vertically. Applicability of design parameters and proper incorporation of component is responsibility of building designer – not truss designer or truss engineer. Bracing shown is for lateral support of individual web members only. Additional temporary bracing to ensure stability during construction is the responsibility of the erector. Additional permanent bracing of the overall structure is the responsibility of the building designer. For general guidance regarding fabrication, quality control, storage, delivery, erection and bracing, consult ANSI/TPI 1 National Design Standard for Metal Plate Connected Wood Truss Construction and BCSI 1-03 Guide to Good Practice for Handling, Installing & Bracing of Metal Plate Connected Wood Trusses from Truss Plate Institute, 583 D'Onofrio Drive, Madison, WI 53719.

Job	Truss	Truss Type	Qty	Ply	LOT 17 VILLAS @ ANDERSON CREEK   66 HAWK RIDGE DRIVE SPRING LAKE,
21-5120-R01	R07	GABLE	1	1	Job Reference (optional) # 28709

8.430 s Feb 12 2021 MiTek Industries, Inc. Thu Sep 30 15:45:27 2021 Page 2  
 ID:xwDXRRIPWrQwmU1uH5\_sXuyd8cO-TEglvr8K1STOkQyP1IXpR3panVWcxnTeE0dQ3wyYPec

**NOTES-** (15-18)

- 14) This truss is designed in accordance with the 2018 International Residential Code sections R502.11.1 and R802.10.2 and referenced standard ANSI/TPI 1.
- 15) Graphical bracing representation does not depict the size, type or the orientation of the brace on the member. Symbol only indicates that the member must be braced.
- 16) Bearing symbols are only graphical representations of a possible bearing condition. Bearing symbols are not considered in the structural design of the truss to support the loads indicated.
- 17) Web bracing shown is for lateral support of individual web members only. Refer to BCSI - Guide to Good Practice for Handling, Installing, Restraining & Bracing of Metal Plate Connected Wood Trusses for additional bracing guidelines, including diagonal bracing.
- 18) SEE BCSI-B3 SUMMARY SHEET- PERMANENT RESTRAING/BRACING OF CHORDS & WEB MEMBERS FOR RECOMMENDED MINIMUM BRACING REQUIREMENTS OF TOP CHORD, BOTTOM CHORD, AND WEB PLANES. IN ADDITION TO THESE MINIMUM GUIDELINES, ALWAYS CONSULT THE PROJECT ARCHITECT OR ENGINEER FOR ADDITIONAL BRACING CONSIDERATIONS.

**LOAD CASE(S)** Standard



9/29/2021

**Warning !—Verify design parameters and read notes before use.** This design is based only upon parameters shown, and is for an individual building component to be installed and loaded vertically. Applicability of design parameters and proper incorporation of component is responsibility of building designer – not truss designer or truss engineer. Bracing shown is for lateral support of individual web members only. Additional temporary bracing to ensure stability during construction is the responsibility of the erector. Additional permanent bracing of the overall structure is the responsibility of the building designer. For general guidance regarding fabrication, quality control, storage, delivery, erection and bracing, consult ANSI/TPI 1 *National Design Standard for Metal Plate Connected Wood Truss Construction* and BCSI 1-03 *Guide to Good Practice for Handling, Installing & Bracing of Metal Plate Connected Wood Trusses* from Truss Plate Institute, 583 D'Onofrio Drive, Madison, WI 53719.



Job	Truss	Truss Type	Qty	Ply	LOT 17 VILLAS @ ANDERSON CREEK   66 HAWK RIDGE DRIVE SPRING LAKE, NC
21-5120-R01	R08	Attic	6	1	# 28709

8.430 s Feb 12 2021 MiTek Industries, Inc. Thu Sep 30 15:45:29 2021 Page 1  
 ID: xwDXRRIPWrQwmU1uH5 sXuyd8cO-PcoVKXAaZ3j6zk5n89aHWUvpzJ5QPvUxhJ6X8oyYPea

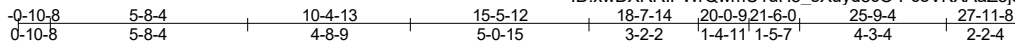

Scale = 1:66.1

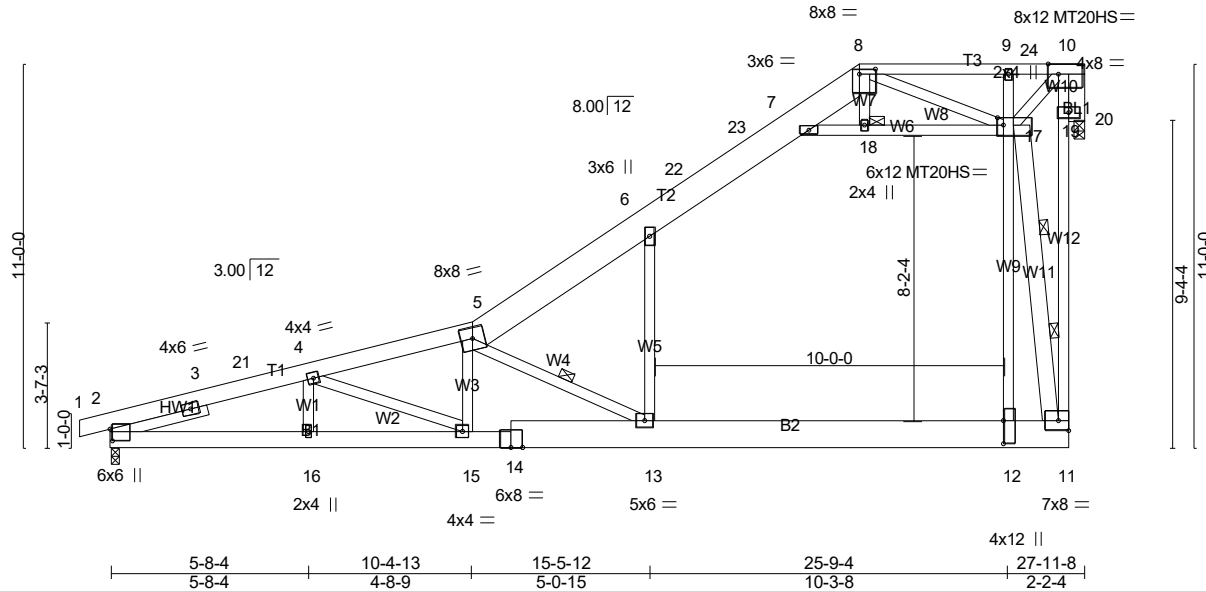

Plate Offsets (X,Y)-- [2:0-4-1,0-0-13], [8:0-5-8,0-1-12], [10:0-3-8,Edge], [12:0-8-0,0-0-0], [17:0-2-0,0-2-8]

LOADING (psf)	SPACING-	2-0-0	CSI.	DEFL.	in (loc)	l/defl	L/d	PLATES	GRIP
TCLL (roof) 20.0	Plate Grip DOL 1.15		TC 0.91	Vert(LL) -0.55	13	>612	240	MT20	244/190
Snow (Pf) 20.0	Lumber DOL 1.15		BC 0.73	Vert(CT) -0.99	13	>338	180	MT20HS	187/143
TCDL 10.0	Rep Stress Incr YES		WB 1.00	Horz(CT) 0.21	20	n/a	n/a		
BCLL 0.0 *	Code IRC2018/TPI2014		Matrix-SH	Attic -0.22	12-13	565	360		
BCDL 10.0								Weight: 286 lb	FT = 20%

LUMBER-	BRACING-
<b>TOP CHORD</b> 2x6 SP No.2 *Except* T2: 2x10 SP No.1, T3: 2x4 SP No.1 <b>BOT CHORD</b> 2x6 SP No.1 *Except* B2: 2x10 SP 2400F 2.0E <b>WEBS</b> 2x4 SP No.3 *Except* W12: 2x4 SP SS, W5,W6: 2x4 SP No.2, W9: 2x4 SP No.1 W11: 2x6 SP No.2 <b>OTHERS</b> 2x6 SP No.2 <b>SLIDER</b> Left 2x4 SP No.3 - 2-10-8	<b>TOP CHORD</b> Structural wood sheathing directly applied or 2-2-0 oc purlins, except end verticals. <b>BOT CHORD</b> Rigid ceiling directly applied or 10-0-0 oc bracing, Except: 8-1-14 oc bracing: 12-13. <b>WEBS</b> 1 Row at midpt 5-13 2 Rows at 1/3 pts 11-17 1 Brace at Jt(s): 18 <b>JOINTS</b>

MiTek recommends that Stabilizers and required cross bracing be installed during truss erection, in accordance with Stabilizer Installation guide.

**REACTIONS.** (lb/size) 2=1271/0-3-8 (min. 0-1-9), 20=1327/0-3-8 (min. 0-1-8)  
 Max Horz 2=368(LC 14)  
 Max Uplift 2=-92(LC 14), 20=-53(LC 14)  
 Max Grav 2=1310(LC 5), 20=1727(LC 47)

**FORCES.** (lb) - Max. Comp./Max. Ten. - All forces 250 (lb) or less except when shown.  
**TOP CHORD** 2-3=-3102/104, 3-21=-3047/106, 4-21=-3018/112, 4-5=-3367/50, 5-6=-1678/0, 6-22=-1001/0, 22-23=-932/3, 7-23=-836/14, 7-8=-86/595, 8-9=-296/1763, 9-24=-285/1698, 10-24=-285/1698, 11-19=-530/3828, 10-19=-530/3828  
**BOT CHORD** 2-16=-449/2891, 15-16=-449/2891, 14-15=-335/3223, 13-14=-330/3204, 12-13=-114/1077, 11-12=-113/1055  
**WEBS** 4-15=-160/567, 5-15=-101/571, 5-13=-2532/259, 6-13=0/946, 12-17=-12/2982, 9-17=-737/181, 11-17=-5764/619, 7-18=-1618/92, 17-18=-1590/94, 8-17=-1412/377, 10-17=-2541/421, 10-20=-1763/180

- NOTES-** (16-19)
- 1) Wind: ASCE 7-16; Vult=130mph (3-second gust) Vasd=103mph; TCDL=5.0psf; BCDL=5.0psf; h=23ft; Cat. II; Exp B; Enclosed; MWFRS (envelope) gable end zone and C-C Exterior(2E) 0-10-8 to 3-11-2, Interior(1) 3-11-2 to 16-8-6, Exterior(2R) 16-8-6 to 26-3-10, Interior(1) 26-3-10 to 27-4-4 zone; C-C for members and forces & MWFRS for reactions shown; Lumber DOL=1.60 plate grip DOL=1.60
  - 2) TCLL: ASCE 7-16; Pr=20.0 psf (roof LL: Lum DOL=1.15 Plate DOL=1.15); Pf=20.0 psf (Lum DOL=1.15 Plate DOL=1.15); Is=1.0; Rough Cat B; Partially Exp.; Ce=1.0; Cs=1.00; Ct=1.10
  - 3) Unbalanced snow loads have been considered for this design.
  - 4) This truss has been designed for greater of min roof live load of 12.0 psf or 2.00 times flat roof load of 20.0 psf on overhangs non-concurrent with other live loads.
  - 5) Provide adequate drainage to prevent water ponding.
  - 6) All plates are MT20 plates unless otherwise indicated.
  - 7) The Fabrication Tolerance at joint 17 = 8%
  - 8) This truss has been designed for a 10.0 psf bottom chord live load nonconcurrent with any other live loads.
  - 9) \* This truss has been designed for a live load of 30.0psf on the bottom chord in all areas where a rectangle 3-6-0 tall by 1-0-0 wide will fit between the bottom chord and any other members.
  - 10) Ceiling dead load (5.0 psf) on member(s). 5-6, 6-7, 7-18, 17-18
  - 11) Bottom chord live load (40.0 psf) and additional bottom chord dead load (10.0 psf) applied only to room. 12-13



9/29/2021

Continued on page 2. Design parameters and read notes before use. This design is based only upon parameters shown, and is for an individual building component to be installed and loaded vertically. Applicability of design parameters and proper incorporation of component is responsibility of building designer – not truss designer or truss engineer. Bracing shown is for lateral support of individual web members only. Additional temporary bracing to ensure stability during construction is the responsibility of the erector. Additional permanent bracing of the overall structure is the responsibility of the building designer. For general guidance regarding fabrication, quality control, storage, delivery, erection and bracing, consult ANSI/TPI 1 National Design Standard for Metal Plate Connected Wood Truss Construction and BCSI 1-03 Guide to Good Practice for Handling, Installing & Bracing of Metal Plate Connected Wood Trusses from Truss Plate Institute, 583 D'Onofrio Drive, Madison, WI 53719.

Job	Truss	Truss Type	Qty	Ply	LOT 17 VILLAS @ ANDERSON CREEK   66 HAWK RIDGE DRIVE SPRING LAKE,
21-5120-R01	R08	Attic	6	1	Job Reference (optional) # 28709

8.430 s Feb 12 2021 MiTek Industries, Inc. Thu Sep 30 15:45:30 2021 Page 2  
 ID:xwDXRRIPWrQwmU1uH5\_sXuyd8cO-tpMtXtBCKNrzbbug\_it5W3hR\_jjRf8xk4wzs4gEYYPeZ

**NOTES-** (16-19)

- 12) Bearing at joint(s) 20 considers parallel to grain value using ANSI/TPI 1 angle to grain formula. Building designer should verify capacity of bearing surface.
- 13) Provide mechanical connection (by others) of truss to bearing plate capable of withstanding 100 lb uplift at joint(s) 2, 20.
- 14) This truss is designed in accordance with the 2018 International Residential Code sections R502.11.1 and R802.10.2 and referenced standard ANSI/TPI 1.
- 15) Attic room checked for L/360 deflection.
- 16) Graphical bracing representation does not depict the size, type or the orientation of the brace on the member. Symbol only indicates that the member must be braced.
- 17) Bearing symbols are only graphical representations of a possible bearing condition. Bearing symbols are not considered in the structural design of the truss to support the loads indicated.
- 18) Web bracing shown is for lateral support of individual web members only. Refer to BCSI - Guide to Good Practice for Handling, Installing, Restraining & Bracing of Metal Plate Connected Wood Trusses for additional bracing guidelines, including diagonal bracing.
- 19) SEE BCSI-B3 SUMMARY SHEET- PERMANENT RESTRAING/BRACING OF CHORDS & WEB MEMBERS FOR RECOMMENDED MINIMUM BRACING REQUIREMENTS OF TOP CHORD, BOTTOM CHORD, AND WEB PLANES. IN ADDITION TO THESE MINIMUM GUIDELINES, ALWAYS CONSULT THE PROJECT ARCHITECT OR ENGINEER FOR ADDITIONAL BRACING CONSIDERATIONS.

**LOAD CASE(S)** Standard



9/29/2021

**Warning !—Verify design parameters and read notes before use.** This design is based only upon parameters shown, and is for an individual building component to be installed and loaded vertically. Applicability of design parameters and proper incorporation of component is responsibility of building designer – not truss designer or truss engineer. Bracing shown is for lateral support of individual web members only. Additional temporary bracing to ensure stability during construction is the responsibility of the erector. Additional permanent bracing of the overall structure is the responsibility of the building designer. For general guidance regarding fabrication, quality control, storage, delivery, erection and bracing, consult ANSI/TPI 1 *National Design Standard for Metal Plate Connected Wood Truss Construction* and BCSI 1-03 *Guide to Good Practice for Handling, Installing & Bracing of Metal Plate Connected Wood Trusses* from Truss Plate Institute, 583 D'Onofrio Drive, Madison, WI 53719.

Job 21-5120-R01	Truss R10	Truss Type Common Supported Gable	Qty 1	Ply 1	LOT 17 VILLAS @ ANDERSON CREEK   66 HAWK RIDGE DRIVE SPRING LAKE, Job Reference (optional) # 28709
--------------------	--------------	--------------------------------------	----------	----------	---

8.430 s Feb 12 2021 MiTek Industries, Inc. Thu Sep 30 15:45:31 2021 Page 1  
ID:xwDXRRIPWwRQwmU1uH5\_sXuyd8cO-L?vFIDCq5h\_qC2FAGaclcv\_Mm6xXtbpD9dbdChyYPeY

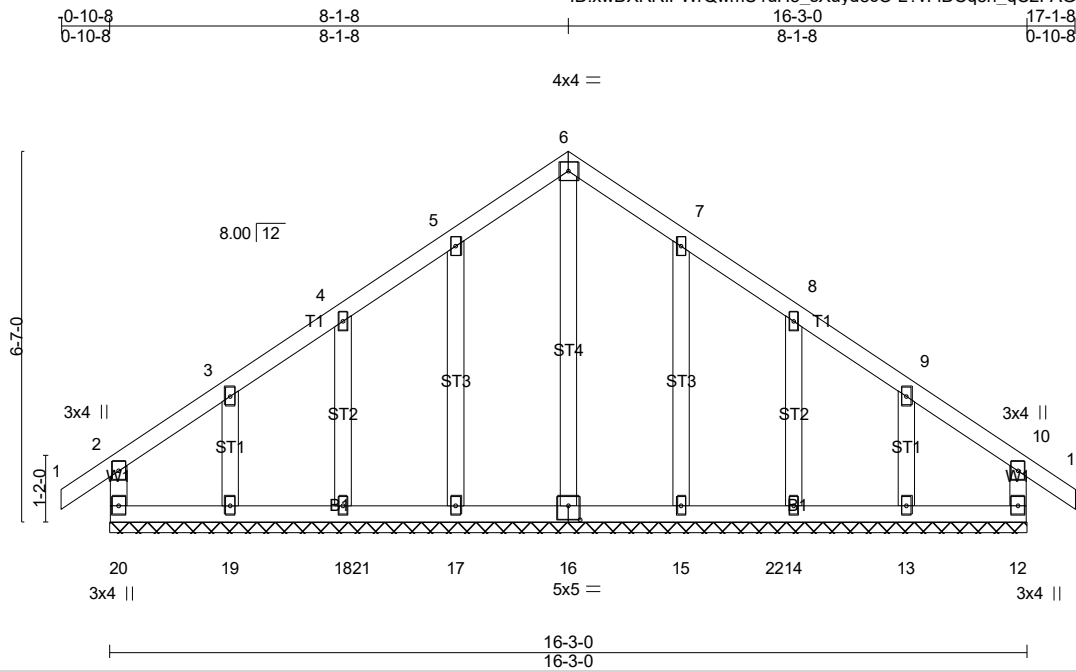

Scale = 1:40.9

Plate Offsets (X,Y)-- [16:0-2-8,0-3-0]

LOADING (psf)	SPACING-	CSI.	DEFL.	in (loc)	l/defl	L/d	PLATES	GRIP
TCLL (roof) 20.0	2-0-0	TC 0.12	Vert(LL) -0.00	11	n/r	180	MT20	244/190
Snow (Pf) 20.0	Plate Grip DOL 1.15	BC 0.11	Vert(CT) -0.00	11	n/r	80		
TCDL 10.0	Lumber DOL 1.15	WB 0.18	Horz(CT) 0.00	12	n/a	n/a		
BCLL 0.0 *	Rep Stress Incr YES	Matrix-R						
BCDL 10.0	Code IRC2018/TPI2014						Weight: 98 lb	FT = 20%

**LUMBER-**  
TOP CHORD 2x4 SP No.2  
BOT CHORD 2x4 SP No.3  
WEBS 2x4 SP No.3  
OTHERS 2x4 SP No.3

**BRACING-**  
TOP CHORD Structural wood sheathing directly applied or 6-0-0 oc purlins, except end verticals.  
BOT CHORD Rigid ceiling directly applied or 6-0-0 oc bracing.

MiTek recommends that Stabilizers and required cross bracing be installed during truss erection, in accordance with Stabilizer Installation guide.

**REACTIONS.** All bearings 16-3-0.  
(lb) - Max Horz 20=-169(LC 10)  
Max Uplift All uplift 100 lb or less at joint(s) 20, 12, 17, 18, 15, 14, 13 except 19=-103(LC 12)  
Max Grav All reactions 250 lb or less at joint(s) 20, 12, 18, 19, 14, 13 except 16=271(LC 23), 17=274(LC 20), 15=273(LC 21)

**FORCES.** (lb) - Max. Comp./Max. Ten. - All forces 250 (lb) or less except when shown.  
TOP CHORD 5-6=-131/279, 6-7=-131/279

- NOTES-** (14-17)
- Unbalanced roof live loads have been considered for this design.
  - Wind: ASCE 7-16; Vult=130mph (3-second gust) Vasd=103mph; TCCL=5.0psf; BCDL=5.0psf; h=23ft; Cat. II; Exp B; Enclosed; MWFRS (envelope) gable end zone and C-C Corner(3E) -0-10-8 to 4-1-8, Corner(3R) 4-1-8 to 12-1-8, Corner(3E) 12-1-8 to 17-1-8 zone; end vertical left and right exposed; C-C for members and forces & MWFRS for reactions shown; Lumber DOL=1.60 plate grip DOL=1.60
  - Truss designed for wind loads in the plane of the truss only. For studs exposed to wind (normal to the face), see Standard Industry Gable End Details as applicable, or consult qualified building designer as per ANSI/TPI 1.
  - TCCL: ASCE 7-16; Pr=20.0 psf (roof LL: Lum DOL=1.15 Plate DOL=1.15); Pf=20.0 psf (Lum DOL=1.15 Plate DOL=1.15); Is=1.0; Rough Cat B; Partially Exp.; Ce=1.0; Cs=1.00; Ct=1.10
  - This truss has been designed for greater of min roof live load of 12.0 psf or 2.00 times flat roof load of 20.0 psf on overhangs non-concurrent with other live loads.
  - All plates are 2x4 MT20 unless otherwise indicated.
  - Gable requires continuous bottom chord bearing.
  - Truss to be fully sheathed from one face or securely braced against lateral movement (i.e. diagonal web).
  - Gable studs spaced at 2-0-0 oc.
  - This truss has been designed for a 10.0 psf bottom chord live load nonconcurrent with any other live loads.
  - \* This truss has been designed for a live load of 30.0psf on the bottom chord in all areas where a rectangle 3-6-0 tall by 1-0-0 wide will fit between the bottom chord and any other members, with BCDL = 10.0psf.
  - Provide mechanical connection (by others) of truss to bearing plate capable of withstanding 100 lb uplift at joint(s) 20, 12, 17, 18, 15, 14, 13 except (jt=lb) 19=103.
  - This truss is designed in accordance with the 2018 International Residential Code sections R502.11.1 and R802.10.2 and referenced standard ANSI/TPI 1.



9/29/2021

Continued on Page 2  
**Design parameters and read notes before use.** This design is based only upon parameters shown, and is for an individual building component to be installed and loaded vertically. Applicability of design parameters and proper incorporation of component is responsibility of building designer – not truss designer or truss engineer. Bracing shown is for lateral support of individual web members only. Additional temporary bracing to ensure stability during construction is the responsibility of the erector. Additional permanent bracing of the overall structure is the responsibility of the building designer. For general guidance regarding fabrication, quality control, storage, delivery, erection and bracing, consult ANSI/TPI 1 *National Design Standard for Metal Plate Connected Wood Truss Construction* and BCSI 1-03 *Guide to Good Practice for Handling, Installing & Bracing of Metal Plate Connected Wood Trusses* from Truss Plate Institute, 583 D'Onofrio Drive, Madison, WI 53719.

Job	Truss	Truss Type	Qty	Ply	LOT 17 VILLAS @ ANDERSON CREEK   66 HAWK RIDGE DRIVE SPRING LAKE, NC
21-5120-R01	R10	Common Supported Gable	1	1	Job Reference (optional) # 28709

8.430 s Feb 12 2021 MiTek Industries, Inc. Thu Sep 30 15:45:32 2021 Page 2

ID:xwDXRRIPWrQwmU1uH5\_sXuyd8cO-pBTeyYCTs\_6hqCqMpl7\_86XXVWHmc23NOHLBk7yYPeX

- 14) Graphical bracing representation does not depict the size, type or the orientation of the brace on the member. Symbol only indicates that the member must be braced.
- 15) Bearing symbols are only graphical representations of a possible bearing condition. Bearing symbols are not considered in the structural design of the truss to support the loads indicated.
- 16) Web bracing shown is for lateral support of individual web members only. Refer to BCSI - Guide to Good Practice for Handling, Installing, Restraining & Bracing of Metal Plate Connected Wood Trusses for additional bracing guidelines, including diagonal bracing.
- 17) SEE BCSI-B3 SUMMARY SHEET- PERMANENT RESTRAING/BRACING OF CHORDS & WEB MEMBERS FOR RECOMMENDED MINIMUM BRACING REQUIREMENTS OF TOP CHORD, BOTTOM CHORD, AND WEB PLANES. IN ADDITION TO THESE MINIMUM GUIDELINES, ALWAYS CONSULT THE PROJECT ARCHITECT OR ENGINEER FOR ADDITIONAL BRACING CONSIDERATIONS.

**LOAD CASE(S)** Standard



9/29/2021

**Warning !—Verify design parameters and read notes before use.** This design is based only upon parameters shown, and is for an individual building component to be installed and loaded vertically. Applicability of design parameters and proper incorporation of component is responsibility of building designer – not truss designer or truss engineer. Bracing shown is for lateral support of individual web members only. Additional temporary bracing to ensure stability during construction is the responsibility of the erector. Additional permanent bracing of the overall structure is the responsibility of the building designer. For general guidance regarding fabrication, quality control, storage, delivery, erection and bracing, consult ANSI/TPI 1 *National Design Standard for Metal Plate Connected Wood Truss Construction* and BCSI 1-03 *Guide to Good Practice for Handling, Installing & Bracing of Metal Plate Connected Wood Trusses* from Truss Plate Institute, 583 D'Onofrio Drive, Madison, WI 53719.

Job	Truss	Truss Type	Qty	Ply	LOT 17 VILLAS @ ANDERSON CREEK   66 HAWK RIDGE DRIVE SPRING LAKE,
21-5120-R01	R11	Common	5	1	# 28709

8.430 s Feb 12 2021 MiTek Industries, Inc. Thu Sep 30 15:45:33 2021 Page 1  
 ID:xwDXRRIPWrQwmU1uH5\_sXuyd8cO-IO109uD5dIEYSLPZN?eDhK3e4wVCLT7Wcx4kHZyYPeW

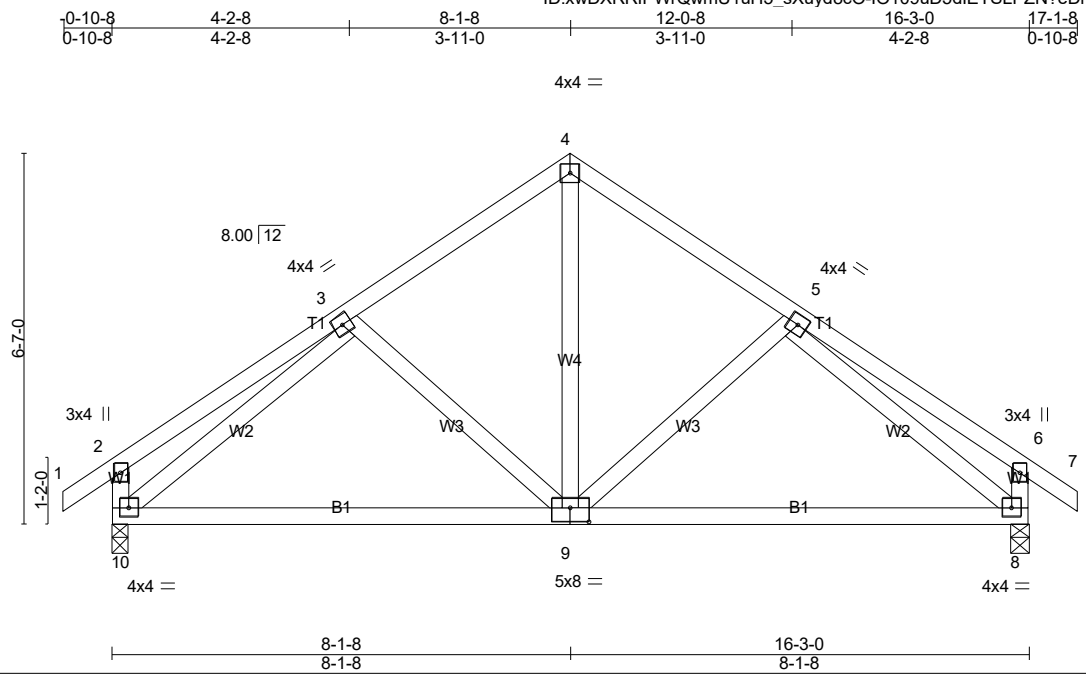

Scale = 1:40.9

Plate Offsets (X,Y)-- [9:0-4-0-0-3-0]	
<b>LOADING</b> (psf)	<b>SPACING-</b>
TCLL (roof) 20.0	2-0-0
Snow (Pf) 20.0	Plate Grip DOL 1.15
TCDL 10.0	Lumber DOL 1.15
BCLL 0.0 *	Rep Stress Incr YES
BCDL 10.0	Code IRC2018/TPI2014
<b>CSI.</b>	<b>DEFL.</b>
TC 0.32	in (loc) l/defl L/d
BC 0.61	Vert(LL) -0.08 9-10 >999 240
WB 0.32	Vert(CT) -0.17 9-10 >999 180
Matrix-SH	Horz(CT) 0.01 8 n/a n/a
<b>PLATES</b>	<b>GRIP</b>
MT20	244/190
Weight: 98 lb FT = 20%	

<b>LUMBER-</b>	<b>BRACING-</b>
TOP CHORD 2x4 SP No.2	TOP CHORD Structural wood sheathing directly applied or 6-0-0 oc purlins, except end verticals.
BOT CHORD 2x4 SP No.2	BOT CHORD Rigid ceiling directly applied or 10-0-0 oc bracing.
WEBS 2x4 SP No.3	MiTek recommends that Stabilizers and required cross bracing be installed during truss erection, in accordance with Stabilizer Installation guide.

**REACTIONS.** (lb/size) 10=700/0-3-8 (min. 0-1-8), 8=700/0-3-8 (min. 0-1-8)  
 Max Horz 10=-169(LC 10)  
 Max Uplift 10=-99(LC 12), 8=-99(LC 13)

**FORCES.** (lb) - Max. Comp./Max. Ten. - All forces 250 (lb) or less except when shown.  
 TOP CHORD 3-4=-588/160, 4-5=-588/160, 2-10=-259/118, 6-8=-259/118  
 BOT CHORD 9-10=-99/564, 8-9=-35/525  
 WEBS 4-9=-74/386, 3-10=-562/82, 5-8=-562/82

- NOTES-** (9-12)
- Unbalanced roof live loads have been considered for this design.
  - Wind: ASCE 7-16; Vult=130mph (3-second gust) Vasd=103mph; TCCL=5.0psf; BCDL=5.0psf; h=23ft; Cat. II; Exp B; Enclosed; MWFRS (envelope) gable end zone and C-C Exterior(2E) -0-10-8 to 4-1-2, Exterior(2R) 4-1-2 to 12-1-14, Exterior(2E) 12-1-14 to 17-1-8 zone; end vertical left and right exposed; C-C for members and forces & MWFRS for reactions shown; Lumber DOL=1.60 plate grip DOL=1.60
  - TCCL: ASCE 7-16; Pr=20.0 psf (roof LL: Lum DOL=1.15 Plate DOL=1.15); Pf=20.0 psf (Lum DOL=1.15 Plate DOL=1.15); Is=1.0; Rough Cat B; Partially Exp.; Ce=1.0; Cs=1.00; Ct=1.10
  - This truss has been designed for greater of min roof live load of 12.0 psf or 2.00 times flat roof load of 20.0 psf on overhangs non-concurrent with other live loads.
  - This truss has been designed for a 10.0 psf bottom chord live load nonconcurrent with any other live loads.
  - \* This truss has been designed for a live load of 30.0psf on the bottom chord in all areas where a rectangle 3-6-0 tall by 1-0-0 wide will fit between the bottom chord and any other members.
  - Provide mechanical connection (by others) of truss to bearing plate capable of withstanding 100 lb uplift at joint(s) 10, 8.
  - This truss is designed in accordance with the 2018 International Residential Code sections R502.11.1 and R802.10.2 and referenced standard ANSI/TPI 1.
  - Graphical bracing representation does not depict the size, type or the orientation of the brace on the member. Symbol only indicates that the member must be braced.
  - Bearing symbols are only graphical representations of a possible bearing condition. Bearing symbols are not considered in the structural design of the truss to support the loads indicated.
  - Web bracing shown is for lateral support of individual web members only. Refer to BCSI - Guide to Good Practice for Handling, Installing, Restraining & Bracing of Metal Plate Connected Wood Trusses for additional bracing guidelines, including diagonal bracing.
  - SEE BCSI-B3 SUMMARY SHEET- PERMANENT RESTRAINING/BRACING OF CHORDS & WEB MEMBERS FOR RECOMMENDED MINIMUM BRACING REQUIREMENTS OF TOP CHORD, BOTTOM CHORD, AND WEB PLANES. IN ADDITION TO THESE MINIMUM GUIDELINES, ALWAYS CONSULT THE PROJECT ARCHITECT OR ENGINEER FOR ADDITIONAL BRACING CONSIDERATIONS.

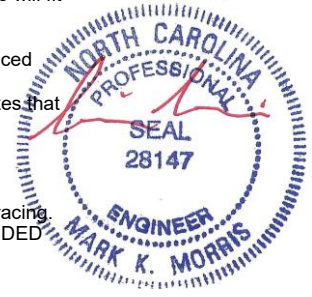

9/29/2021

**LOAD CASE(S)** Standard  
**Warning!** Verify design parameters and read notes before use. This design is based only upon parameters shown, and is for an individual building component to be installed and loaded vertically. Applicability of design parameters and proper incorporation of component is responsibility of building designer – not truss designer or truss engineer. Bracing shown is for lateral support of individual web members only. Additional temporary bracing to ensure stability during construction is the responsibility of the erector. Additional permanent bracing of the overall structure is the responsibility of the building designer. For general guidance regarding fabrication, quality control, storage, delivery, erection and bracing, consult ANSI/TPI 1 *National Design Standard for Metal Plate Connected Wood Truss Construction* and BCSI 1-03 *Guide to Good Practice for Handling, Installing & Bracing of Metal Plate Connected Wood Trusses* from Truss Plate Institute, 583 D'Onofrio Drive, Madison, WI 53719.

Job 21-5120-R01	Truss R12	Truss Type Common Girder	Qty 1	Ply 2	LOT 17 VILLAS @ ANDERSON CREEK   66 HAWK RIDGE DRIVE SPRING LAKE, NC 28709
--------------------	--------------	-----------------------------	----------	----------	--

8.430 s Feb 12 2021 MiTek Industries, Inc. Thu Sep 30 15:45:35 2021 Page 1  
 ID:xwDXRRIPWrQwmU1uH5\_sXuyd8cO-Em9maaFL9vUFhfZxVQhml9xOk4spCHp4FZrLSyPeU

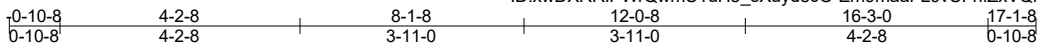

5x8 ||

Scale = 1:40.3

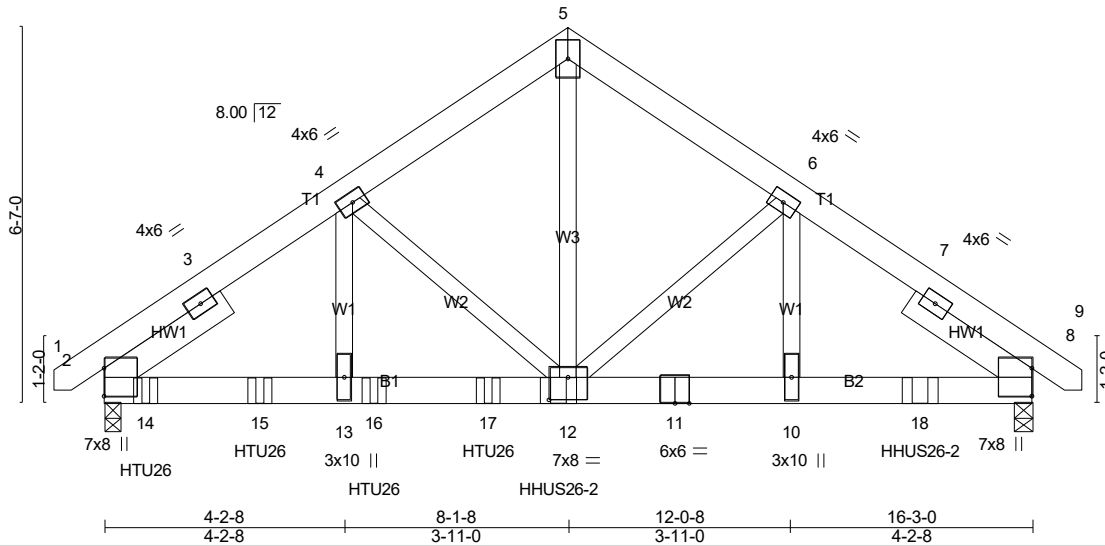

Plate Offsets (X,Y)-- [12:0-4-0,0-4-12]

<b>LOADING</b> (psf)	<b>SPACING-</b>	<b>CSI.</b>	<b>DEFL.</b>	<b>PLATES</b>	<b>GRIP</b>
TCLL (roof) 20.0	2-0-0	TC 0.53	in (loc) l/defl L/d	MT20	244/190
Snow (Pf) 20.0	Plate Grip DOL 1.15	BC 0.98	Vert(LL) -0.06 12-13 >999 240		
TCDL 10.0	Lumber DOL 1.15	WB 0.98	Vert(CT) -0.11 12-13 >999 180		
BCLL 0.0 *	Rep Stress Incr NO	Matrix-SH	Horz(CT) 0.04 8 n/a n/a		
BCDL 10.0	Code IRC2018/TPI2014			Weight: 265 lb	FT = 20%

**LUMBER-**  
 TOP CHORD 2x6 SP No.2  
 BOT CHORD 2x6 SP No.1  
 WEBS 2x4 SP No.3  
 SLIDER Left 2x6 SP No.2 - 2-6-5, Right 2x6 SP No.2 - 2-6-5

**BRACING-**  
 TOP CHORD Structural wood sheathing directly applied or 5-3-13 oc purlins.  
 BOT CHORD Rigid ceiling directly applied or 10-0-0 oc bracing.

**REACTIONS.** (lb/size) 2=5754/0-3-8 (min. 0-3-6), 8=5160/0-3-8 (min. 0-3-1)  
 Max Horz 2=138(LC 33)  
 Max Uplift 2=-775(LC 10), 8=-715(LC 11)

**FORCES.** (lb) - Max. Comp./Max. Ten. - All forces 250 (lb) or less except when shown.  
 TOP CHORD 2-3=-6570/866, 3-4=-6513/888, 4-5=-4730/703, 5-6=-4759/707, 6-7=-5525/769, 7-8=-5561/738  
 BOT CHORD 2-14=-718/5116, 14-15=-718/5116, 13-15=-718/5116, 13-16=-718/5116, 16-17=-718/5116, 12-17=-718/5116, 11-12=-560/4407, 10-11=-560/4407, 10-18=-560/4407, 8-18=-560/4407  
 WEBS 5-12=-666/4721, 6-12=-607/188, 6-10=-102/982, 4-12=-1554/301, 4-13=-274/2380

**NOTES-** (14-17)

- 2-ply truss to be connected together with 10d (0.131"x3") nails as follows:  
 Top chords connected as follows: 2x6 - 2 rows staggered at 0-9-0 oc.  
 Bottom chords connected as follows: 2x6 - 2 rows staggered at 0-4-0 oc.  
 Webs connected as follows: 2x4 - 1 row at 0-9-0 oc.
- All loads are considered equally applied to all plies, except if noted as front (F) or back (B) face in the LOAD CASE(S) section. Ply to ply connections have been provided to distribute only loads noted as (F) or (B), unless otherwise indicated.
- Unbalanced roof live loads have been considered for this design.
- Wind: ASCE 7-16; Vult=130mph (3-second gust) Vasd=103mph; TCDL=5.0psf; BCDL=5.0psf; h=23ft; Cat. II; Exp B; Enclosed; MWFRS (envelope) gable end zone; Lumber DOL=1.60 plate grip DOL=1.60
- TCLL: ASCE 7-16; Pr=20.0 psf (roof LL: Lum DOL=1.15 Plate DOL=1.15); Pf=20.0 psf (Lum DOL=1.15 Plate DOL=1.15); Is=1.0; Rough Cat B; Partially Exp.; Ce=1.0; Cs=1.00; Ct=1.10
- This truss has been designed for greater of min roof live load of 12.0 psf or 2.00 times flat roof load of 20.0 psf on overhangs non-concurrent with other live loads.
- This truss has been designed for a 10.0 psf bottom chord live load nonconcurrent with any other live loads.
- \* This truss has been designed for a live load of 30.0psf on the bottom chord in all areas where a rectangle 3-6-0 tall by 1-0-0 wide will fit between the bottom chord and any other members.
- Provide mechanical connection (by others) of truss to bearing plate capable of withstanding 100 lb uplift at joint(s) except (jt=lb) 2=725, 8=715.
- This truss is designed in accordance with the 2018 International Residential Code sections R502.11.1 and R802.10.2 and referenced standard ANSI/TPI 1.
- Use Simpson Strong-Tie HTU26 (20-10d Girder, 11-10dx1 1/2 Truss, Single Ply Girder) or equivalent spaced at 2-0-0 oc max. starting at 0-8-12 from the left end to 6-8-12 to connect truss(es) R03 (1 ply 2x4 SP), R04 (1 ply 2x4 SP) to front face of bottom chord.
- Use Simpson Strong-Tie HHUS26-2 (14-10d Girder, 6-10d Truss, Single Ply Girder) or equivalent spaced at 6-4-0 oc max. starting at 7-11-8 from the left end to 14-3-8 to connect truss(es) R05 (2 ply 2x4 SP) to front face of bottom chord.
- Fill all nail holes where hanger is in contact with lumber.

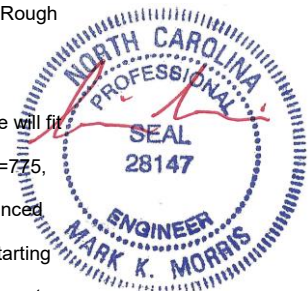

9/29/2021

Continued on Page 2 Design parameters and read notes before use. This design is based only upon parameters shown, and is for an individual building component to be installed and loaded vertically. Applicability of design parameters and proper incorporation of component is responsibility of building designer – not truss designer or truss engineer. Bracing shown is for lateral support of individual web members only. Additional temporary bracing to ensure stability during construction is the responsibility of the erector. Additional permanent bracing of the overall structure is the responsibility of the building designer. For general guidance regarding fabrication, quality control, storage, delivery, erection and bracing, consult ANSI/TPI 1 National Design Standard for Metal Plate Connected Wood Truss Construction and BCSI 1-03 Guide to Good Practice for Handling, Installing & Bracing of Metal Plate Connected Wood Trusses from Truss Plate Institute, 583 D'Onofrio Drive, Madison, WI 53719.

Job	Truss	Truss Type	Qty	Ply	LOT 17 VILLAS @ ANDERSON CREEK   66 HAWK RIDGE DRIVE SPRING LAKE,
21-5120-R01	R12	Common Girder	1	2	Job Reference (optional) # 28709

8.430 s Feb 12 2021 MiTek Industries, Inc. Thu Sep 30 15:45:35 2021 Page 2

ID:xwDXRRIPWrQwmU1uH5\_sXuyd8cO-Em9maaFL9vUFhfZxVQhml9xOk4spCHp4FZrLSyYPeU

- 14) Graphical bracing representation does not depict the size, type or the orientation of the brace on the member. Symbol only indicates that the member must be braced.
- 15) Bearing symbols are only graphical representations of a possible bearing condition. Bearing symbols are not considered in the structural design of the truss to support the loads indicated.
- 16) Web bracing shown is for lateral support of individual web members only. Refer to BCSI - Guide to Good Practice for Handling, Installing, Restraining & Bracing of Metal Plate Connected Wood Trusses for additional bracing guidelines, including diagonal bracing.
- 17) SEE BCSI-B3 SUMMARY SHEET- PERMANENT RESTRAING/BRACING OF CHORDS & WEB MEMBERS FOR RECOMMENDED MINIMUM BRACING REQUIREMENTS OF TOP CHORD, BOTTOM CHORD, AND WEB PLANES. IN ADDITION TO THESE MINIMUM GUIDELINES, ALWAYS CONSULT THE PROJECT ARCHITECT OR ENGINEER FOR ADDITIONAL BRACING CONSIDERATIONS.

**LOAD CASE(S)** Standard

- 1) Dead + Snow (balanced): Lumber Increase=1.15, Plate Increase=1.15
  - Uniform Loads (plf)
    - Vert: 1-5=-60, 5-9=-60, 2-8=-20
  - Concentrated Loads (lb)
    - Vert: 12=-2476(F) 14=-1145(F) 15=-1143(F) 16=-1143(F) 17=-1143(F) 18=-2478(F)



9/29/2021

**Warning !—Verify design parameters and read notes before use.** This design is based only upon parameters shown, and is for an individual building component to be installed and loaded vertically. Applicability of design parameters and proper incorporation of component is responsibility of building designer – not truss designer or truss engineer. Bracing shown is for lateral support of individual web members only. Additional temporary bracing to ensure stability during construction is the responsibility of the erector. Additional permanent bracing of the overall structure is the responsibility of the building designer. For general guidance regarding fabrication, quality control, storage, delivery, erection and bracing, consult ANSI/TPI 1 *National Design Standard for Metal Plate Connected Wood Truss Construction* and BCSI 1-03 *Guide to Good Practice for Handling, Installing & Bracing of Metal Plate Connected Wood Trusses* from Truss Plate Institute, 583 D\*Onofrio Drive, Madison, WI 53719.

Job 21-5120-R01	Truss VT01	Truss Type Valley	Qty 1	Ply 1	LOT 17 VILLAS @ ANDERSON CREEK   66 HAWK RIDGE DRIVE SPRING LAKE, Job Reference (optional) # 28709
--------------------	---------------	----------------------	----------	----------	---

8.430 s Feb 12 2021 MiTek Industries, Inc. Thu Sep 30 15:45:36 2021 Page 1  
ID:xwDXRRIPWwQwmU1uH5\_sXuyd8cO-izj8owFzwDc6Jp8827CwlyhAQ7YrYt5ylvJ0tuyYPeT

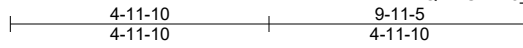

Scale = 1:44.1

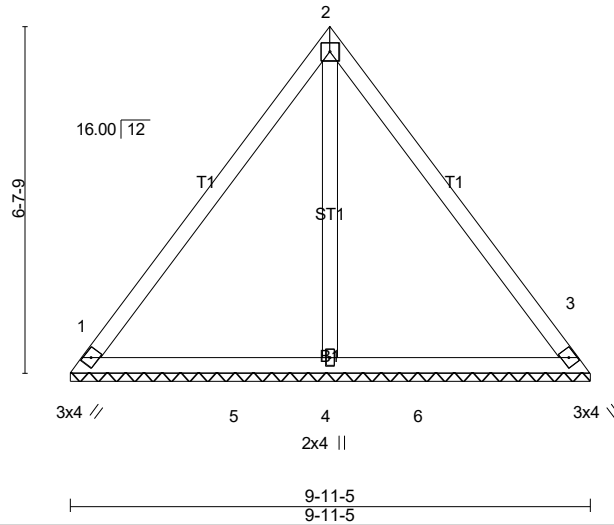

<b>LOADING</b> (psf)	<b>SPACING-</b>	<b>CSI.</b>	<b>DEFL.</b>	<b>PLATES</b>	<b>GRIP</b>
TCLL (roof) 20.0	2-0-0	TC 0.32	in (loc) l/defl L/d	MT20	244/190
Snow (Pf) 20.0	Plate Grip DOL 1.15	BC 0.49	Vert(LL) n/a - n/a 999		
TCDL 10.0	Lumber DOL 1.15	WB 0.11	Vert(CT) n/a - n/a 999		
BCLL 0.0 *	Rep Stress Incr YES	Matrix-SH	Horz(CT) 0.00 3 n/a n/a		
BCDL 10.0	Code IRC2018/TPI2014			Weight: 47 lb	FT = 20%

**LUMBER-**  
TOP CHORD 2x4 SP No.2  
BOT CHORD 2x4 SP No.3  
OTHERS 2x4 SP No.3

**BRACING-**  
TOP CHORD Structural wood sheathing directly applied or 6-0-0 oc purlins.  
BOT CHORD Rigid ceiling directly applied or 10-0-0 oc bracing.

MiTek recommends that Stabilizers and required cross bracing be installed during truss erection, in accordance with Stabilizer Installation guide.

**REACTIONS.** (lb/size) 1=218/9-11-5 (min. 0-1-8), 3=218/9-11-5 (min. 0-1-8), 4=313/9-11-5 (min. 0-1-8)  
Max Horz 1=-155(LC 8)  
Max Uplift 1=-45(LC 13), 3=-32(LC 12), 4=-40(LC 12)  
Max Grav 1=224(LC 20), 3=218(LC 1), 4=449(LC 19)

**FORCES.** (lb) - Max. Comp./Max. Ten. - All forces 250 (lb) or less except when shown.

**NOTES-** (9-12)

- Unbalanced roof live loads have been considered for this design.
- Wind: ASCE 7-16; Vult=130mph (3-second gust) Vasd=103mph; TCDL=5.0psf; BCDL=5.0psf; h=23ft; Cat. II; Exp B; Enclosed; MWFRS (envelope) gable end zone and C-C Exterior(2E) zone; C-C for members and forces & MWFRS for reactions shown; Lumber DOL=1.60 plate grip DOL=1.60
- TCLL: ASCE 7-16; Pr=20.0 psf (roof LL: Lum DOL=1.15 Plate DOL=1.15); Pf=20.0 psf (Lum DOL=1.15 Plate DOL=1.15); Is=1.0; Rough Cat B; Partially Exp.; Ce=1.0; Cs=1.00; Ct=1.10
- Gable requires continuous bottom chord bearing.
- This truss has been designed for a 10.0 psf bottom chord live load nonconcurrent with any other live loads.
- \* This truss has been designed for a live load of 30.0psf on the bottom chord in all areas where a rectangle 3-6-0 tall by 1-0-0 wide will fit between the bottom chord and any other members, with BCDL = 10.0psf.
- Provide mechanical connection (by others) of truss to bearing plate capable of withstanding 100 lb uplift at joint(s) 1, 3, 4.
- This truss is designed in accordance with the 2018 International Residential Code sections R502.11.1 and R802.10.2 and referenced standard ANSI/TPI 1.
- Graphical bracing representation does not depict the size, type or the orientation of the brace on the member. Symbol only indicates that the member must be braced.
- Bearing symbols are only graphical representations of a possible bearing condition. Bearing symbols are not considered in the structural design of the truss to support the loads indicated.
- Web bracing shown is for lateral support of individual web members only. Refer to BCSI - Guide to Good Practice for Handling, Installing, Restraining & Bracing of Metal Plate Connected Wood Trusses for additional bracing guidelines, including diagonal bracing.
- SEE BCSI-B3 SUMMARY SHEET- PERMANENT RESTRAINING/BRACING OF CHORDS & WEB MEMBERS FOR RECOMMENDED MINIMUM BRACING REQUIREMENTS OF TOP CHORD, BOTTOM CHORD, AND WEB PLANES. IN ADDITION TO THESE MINIMUM GUIDELINES, ALWAYS CONSULT THE PROJECT ARCHITECT OR ENGINEER FOR ADDITIONAL BRACING CONSIDERATIONS.

**LOAD CASE(S)** Standard

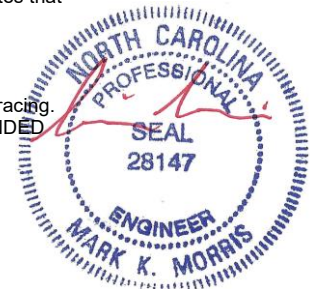

9/29/2021

**Warning !—Verify design parameters and read notes before use.** This design is based only upon parameters shown, and is for an individual building component to be installed and loaded vertically. Applicability of design parameters and proper incorporation of component is responsibility of building designer – not truss designer or truss engineer. Bracing shown is for lateral support of individual web members only. Additional temporary bracing to ensure stability during construction is the responsibility of the erector. Additional permanent bracing of the overall structure is the responsibility of the building designer. For general guidance regarding fabrication, quality control, storage, delivery, erection and bracing, consult ANSI/TPI 1 *National Design Standard for Metal Plate Connected Wood Truss Construction* and BCSI 1-03 *Guide to Good Practice for Handling, Installing & Bracing of Metal Plate Connected Wood Trusses* from Truss Plate Institute, 583 D'Onofrio Drive, Madison, WI 53719.



Job	Truss	Truss Type	Qty	Ply	LOT 17 VILLAS @ ANDERSON CREEK   66 HAWK RIDGE DRIVE SPRING LAKE, NC
21-5120-R01	VT02	Valley	1	1	# 28709

Job Reference (optional) 8.430 s Feb 12 2021 MiTek Industries, Inc. Thu Sep 30 15:45:37 2021 Page 1  
 ID:xwDXRRIPWrQwmU1uH5\_sXuyd8cO-A9HX?GGbhXkzwzjKcrj9rAEIkXxWHK16XZZyQKYYPeS

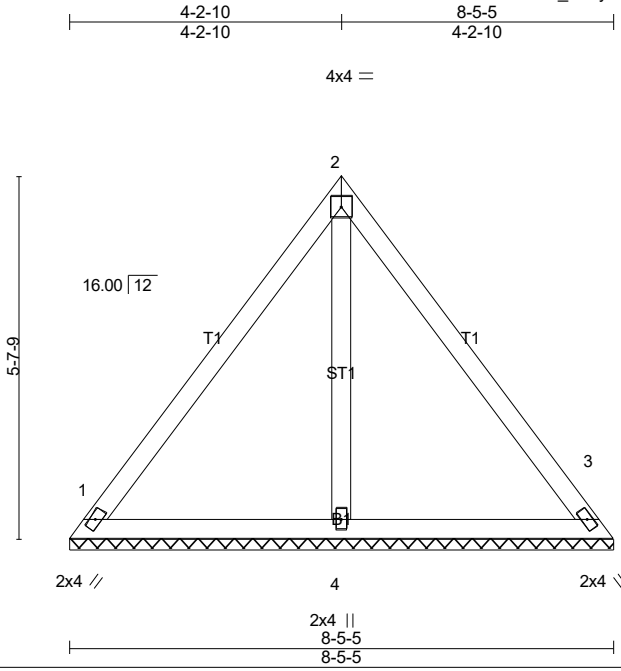

<b>LOADING</b> (psf)	<b>SPACING-</b>	<b>CSI.</b>	<b>DEFL.</b>	<b>PLATES</b>	<b>GRIP</b>
TCLL (roof) 20.0	2-0-0	TC 0.41	in (loc) l/defl L/d	MT20	244/190
Snow (Pf) 20.0	Plate Grip DOL 1.15	BC 0.27	Vert(LL) n/a - n/a 999		
TCDL 10.0	Lumber DOL 1.15	WB 0.07	Vert(CT) n/a - n/a 999		
BCLL 0.0 *	Rep Stress Incr YES	Matrix-P	Horz(CT) 0.00 3 n/a n/a		
BCDL 10.0	Code IRC2018/TPI2014			Weight: 40 lb	FT = 20%

**LUMBER-**  
 TOP CHORD 2x4 SP No.2  
 BOT CHORD 2x4 SP No.3  
 OTHERS 2x4 SP No.3

**BRACING-**  
 TOP CHORD  
 BOT CHORD

Structural wood sheathing directly applied or 6-0-0 oc purlins.  
 Rigid ceiling directly applied or 10-0-0 oc bracing.

MiTek recommends that Stabilizers and required cross bracing be installed during truss erection, in accordance with Stabilizer Installation guide.

**REACTIONS.** (lb/size) 1=203/8-5-5 (min. 0-1-8), 3=203/8-5-5 (min. 0-1-8), 4=223/8-5-5 (min. 0-1-8)  
 Max Horz 1=-130(LC 8)  
 Max Uplift1=-65(LC 13), 3=-54(LC 12)  
 Max Grav 1=203(LC 1), 3=203(LC 1), 4=238(LC 5)

**FORCES.** (lb) - Max. Comp./Max. Ten. - All forces 250 (lb) or less except when shown.

**NOTES-** (9-12)

- Unbalanced roof live loads have been considered for this design.
- Wind: ASCE 7-16; Vult=130mph (3-second gust) Vasd=103mph; TCDL=5.0psf; BCDL=5.0psf; h=23ft; Cat. II; Exp B; Enclosed; MWFRS (envelope) gable end zone and C-C Exterior(2E) zone;C-C for members and forces & MWFRS for reactions shown; Lumber DOL=1.60 plate grip DOL=1.60
- TCLL: ASCE 7-16; Pr=20.0 psf (roof LL: Lum DOL=1.15 Plate DOL=1.15); Pf=20.0 psf (Lum DOL=1.15 Plate DOL=1.15); Is=1.0; Rough Cat B; Partially Exp.; Ce=1.0; Cs=1.00; Ct=1.10
- Gable requires continuous bottom chord bearing.
- This truss has been designed for a 10.0 psf bottom chord live load nonconcurrent with any other live loads.
- \* This truss has been designed for a live load of 30.0psf on the bottom chord in all areas where a rectangle 3-6-0 tall by 1-0-0 wide will fit between the bottom chord and any other members.
- Provide mechanical connection (by others) of truss to bearing plate capable of withstanding 100 lb uplift at joint(s) 1, 3.
- This truss is designed in accordance with the 2018 International Residential Code sections R502.11.1 and R802.10.2 and referenced standard ANSI/TPI 1.
- Graphical bracing representation does not depict the size, type or the orientation of the brace on the member. Symbol only indicates that the member must be braced.
- Bearing symbols are only graphical representations of a possible bearing condition. Bearing symbols are not considered in the structural design of the truss to support the loads indicated.
- Web bracing shown is for lateral support of individual web members only. Refer to BCSI - Guide to Good Practice for Handling, Installing, Restraining & Bracing of Metal Plate Connected Wood Trusses for additional bracing guidelines, including diagonal bracing.
- SEE BCSI-B3 SUMMARY SHEET- PERMANENT RESTRAINING/BRACING OF CHORDS & WEB MEMBERS FOR RECOMMENDED MINIMUM BRACING REQUIREMENTS OF TOP CHORD, BOTTOM CHORD, AND WEB PLANES. IN ADDITION TO THESE MINIMUM GUIDELINES, ALWAYS CONSULT THE PROJECT ARCHITECT OR ENGINEER FOR ADDITIONAL BRACING CONSIDERATIONS.

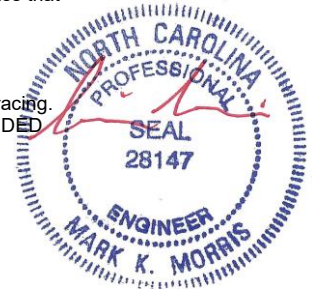

**LOAD CASE(S)** Standard

9/29/2021

**Warning !—Verify design parameters and read notes before use.** This design is based only upon parameters shown, and is for an individual building component to be installed and loaded vertically. Applicability of design parameters and proper incorporation of component is responsibility of building designer – not truss designer or truss engineer. Bracing shown is for lateral support of individual web members only. Additional temporary bracing to ensure stability during construction is the responsibility of the erector. Additional permanent bracing of the overall structure is the responsibility of the building designer. For general guidance regarding fabrication, quality control, storage, delivery, erection and bracing, consult ANSI/TPI 1 *National Design Standard for Metal Plate Connected Wood Truss Construction* and BCSI 1-03 *Guide to Good Practice for Handling, Installing & Bracing of Metal Plate Connected Wood Trusses* from Truss Plate Institute, 583 D'Onofrio Drive, Madison, WI 53719.

Job 21-5120-R01	Truss VT03	Truss Type Valley	Qty 1	Ply 1	LOT 17 VILLAS @ ANDERSON CREEK   66 HAWK RIDGE DRIVE SPRING LAKE, Job Reference (optional) # 28709
--------------------	---------------	----------------------	----------	----------	---

ID:xDXRRIPWrQwmU1uH5\_sXuyd8cO-eLrvDcHDSqsqY7IWAYE00NmVxJA0ojFmDoVynyYPeR  
8.430 s Feb 12 2021 MiTek Industries, Inc. Thu Sep 30 15:45:38 2021 Page 1

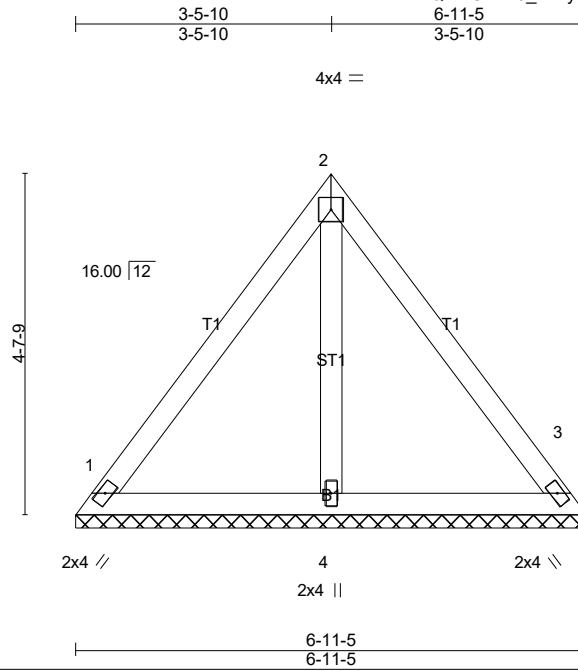

LOADING (psf)	SPACING-	CSI.	DEFL.	PLATES	GRIP
TCLL (roof) 20.0	2-0-0	TC 0.26	in (loc) l/defl L/d	MT20	244/190
Snow (Pf) 20.0	Plate Grip DOL 1.15	BC 0.17	Vert(LL) n/a - n/a 999		
TCDL 10.0	Lumber DOL 1.15	WB 0.04	Vert(CT) n/a - n/a 999		
BCLL 0.0 *	Rep Stress Incr YES	Matrix-P	Horz(CT) 0.00 3 n/a n/a		
BCDL 10.0	Code IRC2018/TPI2014			Weight: 32 lb	FT = 20%

**LUMBER-**  
TOP CHORD 2x4 SP No.2  
BOT CHORD 2x4 SP No.3  
OTHERS 2x4 SP No.3

**BRACING-**  
TOP CHORD  
BOT CHORD

Structural wood sheathing directly applied or 6-0-0 oc purlins.  
Rigid ceiling directly applied or 10-0-0 oc bracing.

MiTek recommends that Stabilizers and required cross bracing be installed during truss erection, in accordance with Stabilizer Installation guide.

**REACTIONS.** (lb/size) 1=164/6-11-5 (min. 0-1-8), 3=164/6-11-5 (min. 0-1-8), 4=180/6-11-5 (min. 0-1-8)  
Max Horz 1=-105(LC 10)  
Max Uplift 1=-52(LC 13), 3=-44(LC 12)  
Max Grav 1=164(LC 1), 3=164(LC 1), 4=193(LC 5)

**FORCES.** (lb) - Max. Comp./Max. Ten. - All forces 250 (lb) or less except when shown.

**NOTES-** (9-12)

- Unbalanced roof live loads have been considered for this design.
- Wind: ASCE 7-16; Vult=130mph (3-second gust) Vasd=103mph; TCDL=5.0psf; BCDL=5.0psf; h=23ft; Cat. II; Exp B; Enclosed; MWFRS (envelope) gable end zone and C-C Exterior(2E) zone; C-C for members and forces & MWFRS for reactions shown; Lumber DOL=1.60 plate grip DOL=1.60
- TCLL: ASCE 7-16; Pr=20.0 psf (roof LL: Lum DOL=1.15 Plate DOL=1.15); Pf=20.0 psf (Lum DOL=1.15 Plate DOL=1.15); Is=1.0; Rough Cat B; Partially Exp.; Ce=1.0; Cs=1.00; Ct=1.10
- Gable requires continuous bottom chord bearing.
- This truss has been designed for a 10.0 psf bottom chord live load nonconcurrent with any other live loads.
- \* This truss has been designed for a live load of 30.0psf on the bottom chord in all areas where a rectangle 3-6-0 tall by 1-0-0 wide will fit between the bottom chord and any other members.
- Provide mechanical connection (by others) of truss to bearing plate capable of withstanding 100 lb uplift at joint(s) 1, 3.
- This truss is designed in accordance with the 2018 International Residential Code sections R502.11.1 and R802.10.2 and referenced standard ANSI/TPI 1.
- Graphical bracing representation does not depict the size, type or the orientation of the brace on the member. Symbol only indicates that the member must be braced.
- Bearing symbols are only graphical representations of a possible bearing condition. Bearing symbols are not considered in the structural design of the truss to support the loads indicated.
- Web bracing shown is for lateral support of individual web members only. Refer to BCSI - Guide to Good Practice for Handling, Installing, Restraining & Bracing of Metal Plate Connected Wood Trusses for additional bracing guidelines, including diagonal bracing.
- SEE BCSI-B3 SUMMARY SHEET- PERMANENT RESTRAINING/BRACING OF CHORDS & WEB MEMBERS FOR RECOMMENDED MINIMUM BRACING REQUIREMENTS OF TOP CHORD, BOTTOM CHORD, AND WEB PLANES. IN ADDITION TO THESE MINIMUM GUIDELINES, ALWAYS CONSULT THE PROJECT ARCHITECT OR ENGINEER FOR ADDITIONAL BRACING CONSIDERATIONS.

**LOAD CASE(S)** Standard

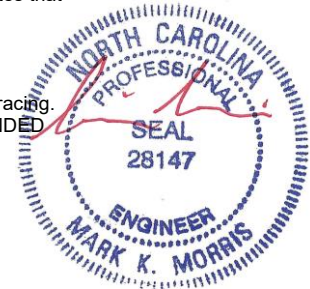

9/29/2021

**Warning !—Verify design parameters and read notes before use.** This design is based only upon parameters shown, and is for an individual building component to be installed and loaded vertically. Applicability of design parameters and proper incorporation of component is responsibility of building designer – not truss designer or truss engineer. Bracing shown is for lateral support of individual web members only. Additional temporary bracing to ensure stability during construction is the responsibility of the erector. Additional permanent bracing of the overall structure is the responsibility of the building designer. For general guidance regarding fabrication, quality control, storage, delivery, erection and bracing, consult ANSI/TPI 1 *National Design Standard for Metal Plate Connected Wood Truss Construction* and BCSI 1-03 *Guide to Good Practice for Handling, Installing & Bracing of Metal Plate Connected Wood Trusses* from Truss Plate Institute, 583 D\*Onofrio Drive, Madison, WI 53719.

Job	Truss	Truss Type	Qty	Ply	LOT 17 VILLAS @ ANDERSON CREEK   66 HAWK RIDGE DRIVE SPRING LAKE, NC
21-5120-R01	VT04	Valley	1	1	

# 28709

8.430 s Feb 12 2021 MiTek Industries, Inc. Thu Sep 30 15:45:39 2021 Page 1  
 ID:xwDXRRIPWrQwmU1uH5\_sXuyd8cO-6YOHQyIsD8\_hAGsikGldwbJiGLgXIFDP?IX3UDyYPeQ

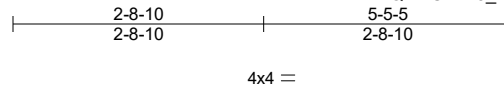

Scale = 1:25.2

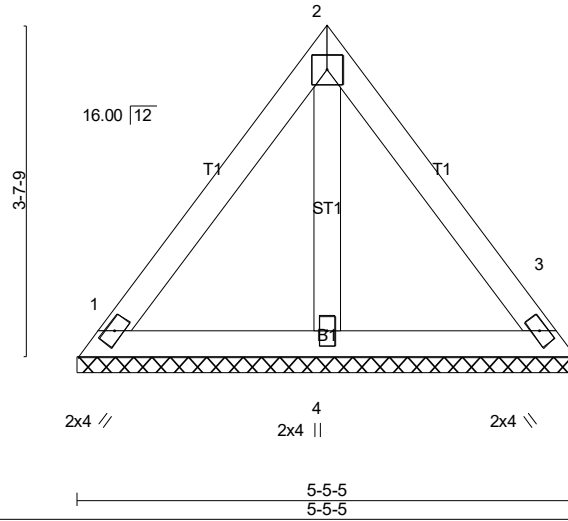

<b>LOADING</b> (psf)	<b>SPACING-</b>	<b>CSI.</b>	<b>DEFL.</b>	<b>PLATES</b>	<b>GRIP</b>
TCLL (roof) 20.0	2-0-0	TC 0.15	in (loc) l/defl L/d	MT20	244/190
Snow (Pf) 20.0	Plate Grip DOL 1.15	BC 0.10	Vert(LL) n/a - n/a 999		
TCDL 10.0	Lumber DOL 1.15	WB 0.02	Vert(CT) n/a - n/a 999		
BCLL 0.0 *	Rep Stress Incr YES	Matrix-P	Horz(CT) 0.00 3 n/a n/a		
BCDL 10.0	Code IRC2018/TPI2014			Weight: 25 lb	FT = 20%

**LUMBER-**  
 TOP CHORD 2x4 SP No.2  
 BOT CHORD 2x4 SP No.3  
 OTHERS 2x4 SP No.3

**BRACING-**  
 TOP CHORD  
 BOT CHORD

Structural wood sheathing directly applied or 5-5-5 oc purlins.  
 Rigid ceiling directly applied or 10-0-0 oc bracing.

MiTek recommends that Stabilizers and required cross bracing be installed during truss erection, in accordance with Stabilizer Installation guide.

**REACTIONS.** (lb/size) 1=126/5-5-5 (min. 0-1-8), 3=126/5-5-5 (min. 0-1-8), 4=138/5-5-5 (min. 0-1-8)  
 Max Horz 1=-80(LC 8)  
 Max Uplift 1=-40(LC 13), 3=-33(LC 12)  
 Max Grav 1=126(LC 1), 3=126(LC 1), 4=147(LC 5)

**FORCES.** (lb) - Max. Comp./Max. Ten. - All forces 250 (lb) or less except when shown.

**NOTES-** (9-12)

- Unbalanced roof live loads have been considered for this design.
- Wind: ASCE 7-16; Vult=130mph (3-second gust) Vasd=103mph; TCDL=5.0psf; BCDL=5.0psf; h=23ft; Cat. II; Exp B; Enclosed; MWFRS (envelope) gable end zone and C-C Exterior(2E) zone; C-C for members and forces & MWFRS for reactions shown; Lumber DOL=1.60 plate grip DOL=1.60
- TCLL: ASCE 7-16; Pr=20.0 psf (roof LL: Lum DOL=1.15 Plate DOL=1.15); Pf=20.0 psf (Lum DOL=1.15 Plate DOL=1.15); Is=1.0; Rough Cat B; Partially Exp.; Ce=1.0; Cs=1.00; Ct=1.10
- Gable requires continuous bottom chord bearing.
- This truss has been designed for a 10.0 psf bottom chord live load nonconcurrent with any other live loads.
- \* This truss has been designed for a live load of 30.0psf on the bottom chord in all areas where a rectangle 3-6-0 tall by 1-0-0 wide will fit between the bottom chord and any other members.
- Provide mechanical connection (by others) of truss to bearing plate capable of withstanding 100 lb uplift at joint(s) 1, 3.
- This truss is designed in accordance with the 2018 International Residential Code sections R502.11.1 and R802.10.2 and referenced standard ANSI/TPI 1.
- Graphical bracing representation does not depict the size, type or the orientation of the brace on the member. Symbol only indicates that the member must be braced.
- Bearing symbols are only graphical representations of a possible bearing condition. Bearing symbols are not considered in the structural design of the truss to support the loads indicated.
- Web bracing shown is for lateral support of individual web members only. Refer to BCSI - Guide to Good Practice for Handling, Installing, Restraining & Bracing of Metal Plate Connected Wood Trusses for additional bracing guidelines, including diagonal bracing.
- SEE BCSI-B3 SUMMARY SHEET- PERMANENT RESTRAINING/BRACING OF CHORDS & WEB MEMBERS FOR RECOMMENDED MINIMUM BRACING REQUIREMENTS OF TOP CHORD, BOTTOM CHORD, AND WEB PLANES. IN ADDITION TO THESE MINIMUM GUIDELINES, ALWAYS CONSULT THE PROJECT ARCHITECT OR ENGINEER FOR ADDITIONAL BRACING CONSIDERATIONS.

**LOAD CASE(S)** Standard

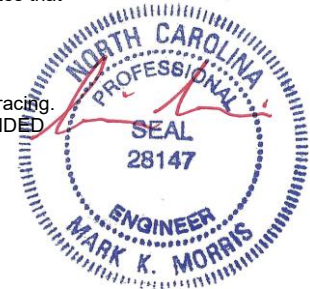

9/29/2021

**Warning !—Verify design parameters and read notes before use.** This design is based only upon parameters shown, and is for an individual building component to be installed and loaded vertically. Applicability of design parameters and proper incorporation of component is responsibility of building designer – not truss designer or truss engineer. Bracing shown is for lateral support of individual web members only. Additional temporary bracing to ensure stability during construction is the responsibility of the erector. Additional permanent bracing of the overall structure is the responsibility of the building designer. For general guidance regarding fabrication, quality control, storage, delivery, erection and bracing, consult ANSI/TPI 1 *National Design Standard for Metal Plate Connected Wood Truss Construction* and BCSI 1-03 *Guide to Good Practice for Handling, Installing & Bracing of Metal Plate Connected Wood Trusses* from Truss Plate Institute, 583 D\*Onofrio Drive, Madison, WI 53719.

Job 21-5120-R01	Truss VT05	Truss Type Valley	Qty 1	Ply 1	LOT 17 VILLAS @ ANDERSON CREEK   66 HAWK RIDGE DRIVE SPRING LAKE, Job Reference (optional) # 28709
--------------------	---------------	----------------------	----------	----------	---

8.430 s Feb 12 2021 MiTek Industries, Inc. Thu Sep 30 15:45:40 2021 Page 1  
ID:xwDXRRIPWrQwmU1uH5\_sXuyd8cO-akyfeliU\_S6YnQRvHzGsTosuJL\_qUinYDXHc1fyYPEP

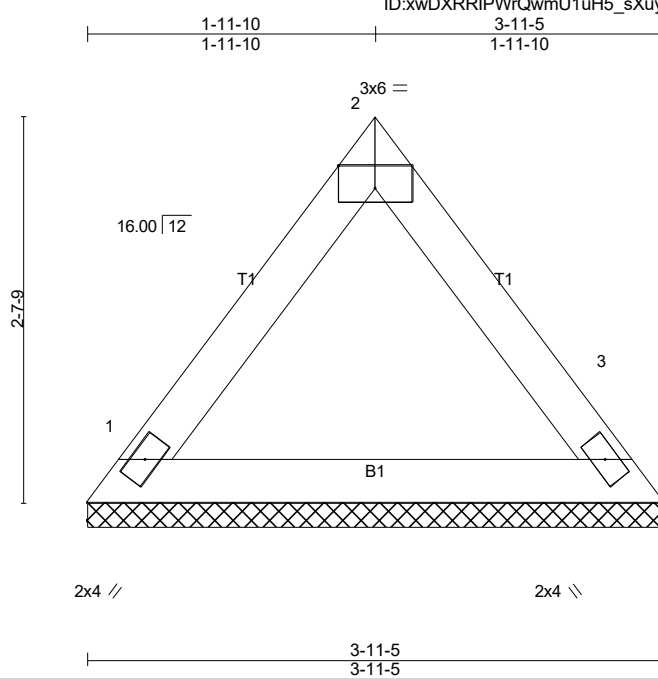

Scale = 1:15.7

Plate Offsets (X,Y)-- [2:Edge,0-1-13]

LOADING (psf)	SPACING-	CSI.	DEFL.	in (loc)	l/defl	L/d	PLATES	GRIP
TCLL (roof) 20.0	2-0-0	TC 0.07	Vert(LL)	n/a	-	n/a	MT20	244/190
Snow (Pf) 20.0	Plate Grip DOL 1.15	BC 0.23	Vert(CT)	n/a	-	n/a		
TCDL 10.0	Lumber DOL 1.15	WB 0.00	Horz(CT)	0.00	3	n/a		
BCLL 0.0 *	Rep Stress Incr YES	Matrix-P						
BCDL 10.0	Code IRC2018/TPI2014						Weight: 15 lb	FT = 20%

**LUMBER-**  
TOP CHORD 2x4 SP No.2  
BOT CHORD 2x4 SP No.3

**BRACING-**  
TOP CHORD Structural wood sheathing directly applied or 3-11-5 oc purlins.  
BOT CHORD Rigid ceiling directly applied or 10-0-0 oc bracing.

MiTek recommends that Stabilizers and required cross bracing be installed during truss erection, in accordance with Stabilizer Installation guide.

**REACTIONS.** (lb/size) 1=134/3-11-5 (min. 0-1-8), 3=134/3-11-5 (min. 0-1-8)  
Max Horz 1=-56(LC 8)  
Max Uplift 1=-19(LC 13), 3=-19(LC 12)

**FORCES.** (lb) - Max. Comp./Max. Ten. - All forces 250 (lb) or less except when shown.

**NOTES-** (9-12)

- Unbalanced roof live loads have been considered for this design.
- Wind: ASCE 7-16; Vult=130mph (3-second gust) Vasd=103mph; TCDL=5.0psf; BCDL=5.0psf; h=23ft; Cat. II; Exp B; Enclosed; MWFRS (envelope) gable end zone and C-C Exterior(2E) zone; C-C for members and forces & MWFRS for reactions shown; Lumber DOL=1.60 plate grip DOL=1.60
- TCLL: ASCE 7-16; Pr=20.0 psf (roof LL: Lum DOL=1.15 Plate DOL=1.15); Pf=20.0 psf (Lum DOL=1.15 Plate DOL=1.15); Is=1.0; Rough Cat B; Partially Exp.; Ce=1.0; Cs=1.00; Ct=1.10
- Gable requires continuous bottom chord bearing.
- This truss has been designed for a 10.0 psf bottom chord live load nonconcurrent with any other live loads.
- \* This truss has been designed for a live load of 30.0psf on the bottom chord in all areas where a rectangle 3-6-0 tall by 1-0-0 wide will fit between the bottom chord and any other members.
- Provide mechanical connection (by others) of truss to bearing plate capable of withstanding 100 lb uplift at joint(s) 1, 3.
- This truss is designed in accordance with the 2018 International Residential Code sections R502.11.1 and R802.10.2 and referenced standard ANSI/TPI 1.
- Graphical bracing representation does not depict the size, type or the orientation of the brace on the member. Symbol only indicates that the member must be braced.
- Bearing symbols are only graphical representations of a possible bearing condition. Bearing symbols are not considered in the structural design of the truss to support the loads indicated.
- Web bracing shown is for lateral support of individual web members only. Refer to BCSI - Guide to Good Practice for Handling, Installing, Restraining & Bracing of Metal Plate Connected Wood Trusses for additional bracing guidelines, including diagonal bracing.
- SEE BCSI-B3 SUMMARY SHEET- PERMANENT RESTRAINING/BRACING OF CHORDS & WEB MEMBERS FOR RECOMMENDED MINIMUM BRACING REQUIREMENTS OF TOP CHORD, BOTTOM CHORD, AND WEB PLANES. IN ADDITION TO THESE MINIMUM GUIDELINES, ALWAYS CONSULT THE PROJECT ARCHITECT OR ENGINEER FOR ADDITIONAL BRACING CONSIDERATIONS.

**LOAD CASE(S)** Standard

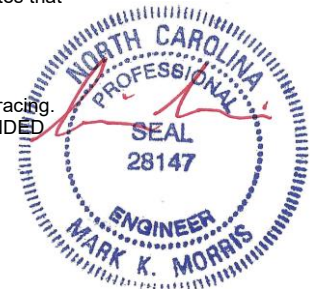

9/29/2021

**Warning !—Verify design parameters and read notes before use.** This design is based only upon parameters shown, and is for an individual building component to be installed and loaded vertically. Applicability of design parameters and proper incorporation of component is responsibility of building designer – not truss designer or truss engineer. Bracing shown is for lateral support of individual web members only. Additional temporary bracing to ensure stability during construction is the responsibility of the erector. Additional permanent bracing of the overall structure is the responsibility of the building designer. For general guidance regarding fabrication, quality control, storage, delivery, erection and bracing, consult ANSI/TPI 1 *National Design Standard for Metal Plate Connected Wood Truss Construction* and BCSI 1-03 *Guide to Good Practice for Handling, Installing & Bracing of Metal Plate Connected Wood Trusses* from Truss Plate Institute, 583 D\*Onofrio Drive, Madison, WI 53719.

Job	Truss	Truss Type	Qty	Ply	LOT 17 VILLAS @ ANDERSON CREEK   66 HAWK RIDGE DRIVE SPRING LAKE, NC
21-5120-R01	VT06	Valley	1	1	Job Reference (optional) # 28709

8.430 s Feb 12 2021 MiTek Industries, Inc. Thu Sep 30 15:45:41 2021 Page 1  
 ID:xwDXRRIPWrQwmU1uH5\_sXuyd8cO-3wW1rdJ6kiEPPa05rhn5?0O4q8LbD91iSB09Z6yYPeO

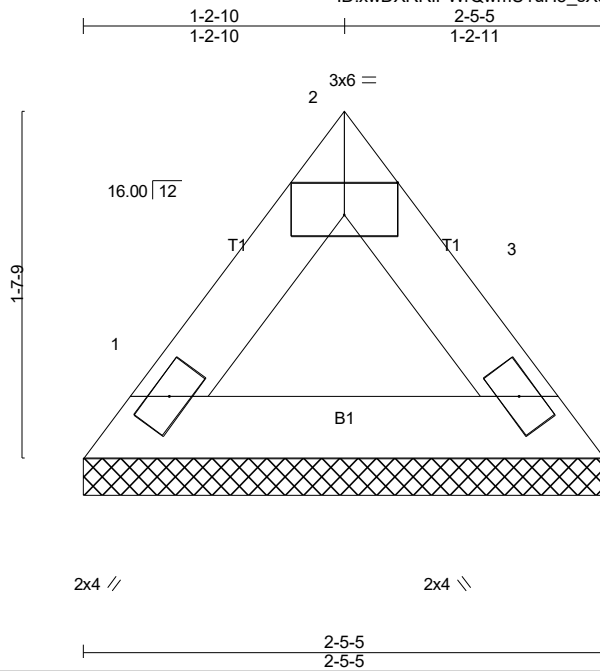

Scale = 1:10.8

Plate Offsets (X,Y)-- [2:Edge,0-1-13]

LOADING (psf)	SPACING-	CSI.	DEFL.	in (loc)	l/defl	L/d	PLATES	GRIP
TCLL (roof) 20.0	2-0-0	TC 0.02	Vert(LL)	n/a	-	n/a	MT20	244/190
Snow (Pf) 20.0	Plate Grip DOL 1.15	BC 0.06	Vert(CT)	n/a	-	n/a		
TCDL 10.0	Lumber DOL 1.15	WB 0.00	Horz(CT)	0.00	3	n/a		
BCLL 0.0 *	Rep Stress Incr YES	Matrix-P						
BCDL 10.0	Code IRC2018/TPI2014						Weight: 9 lb	FT = 20%

**LUMBER-**  
 TOP CHORD 2x4 SP No.2  
 BOT CHORD 2x4 SP No.3

**BRACING-**  
 TOP CHORD Structural wood sheathing directly applied or 2-5-5 oc purlins.  
 BOT CHORD Rigid ceiling directly applied or 10-0-0 oc bracing.

MiTek recommends that Stabilizers and required cross bracing be installed during truss erection, in accordance with Stabilizer Installation guide.

**REACTIONS.** (lb/size) 1=74/2-5-5 (min. 0-1-8), 3=74/2-5-5 (min. 0-1-8)  
 Max Horz 1=-31(LC 8)  
 Max Uplift 1=-10(LC 13), 3=-10(LC 12)

**FORCES.** (lb) - Max. Comp./Max. Ten. - All forces 250 (lb) or less except when shown.

**NOTES-** (9-12)

- Unbalanced roof live loads have been considered for this design.
- Wind: ASCE 7-16; Vult=130mph (3-second gust) Vasd=103mph; TCDL=5.0psf; BCDL=5.0psf; h=23ft; Cat. II; Exp B; Enclosed; MWFRS (envelope) gable end zone and C-C Exterior(2E) zone;C-C for members and forces & MWFRS for reactions shown; Lumber DOL=1.60 plate grip DOL=1.60
- TCLL: ASCE 7-16; Pr=20.0 psf (roof LL: Lum DOL=1.15 Plate DOL=1.15); Pf=20.0 psf (Lum DOL=1.15 Plate DOL=1.15); Is=1.0; Rough Cat B; Partially Exp.; Ce=1.0; Cs=1.00; Ct=1.10
- Gable requires continuous bottom chord bearing.
- This truss has been designed for a 10.0 psf bottom chord live load nonconcurrent with any other live loads.
- \* This truss has been designed for a live load of 30.0psf on the bottom chord in all areas where a rectangle 3-6-0 tall by 1-0-0 wide will fit between the bottom chord and any other members.
- Provide mechanical connection (by others) of truss to bearing plate capable of withstanding 100 lb uplift at joint(s) 1, 3.
- This truss is designed in accordance with the 2018 International Residential Code sections R502.11.1 and R802.10.2 and referenced standard ANSI/TPI 1.
- Graphical bracing representation does not depict the size, type or the orientation of the brace on the member. Symbol only indicates that the member must be braced.
- Bearing symbols are only graphical representations of a possible bearing condition. Bearing symbols are not considered in the structural design of the truss to support the loads indicated.
- Web bracing shown is for lateral support of individual web members only. Refer to BCSI - Guide to Good Practice for Handling, Installing, Restraining & Bracing of Metal Plate Connected Wood Trusses for additional bracing guidelines, including diagonal bracing.
- SEE BCSI-B3 SUMMARY SHEET- PERMANENT RESTRAINING/BRACING OF CHORDS & WEB MEMBERS FOR RECOMMENDED MINIMUM BRACING REQUIREMENTS OF TOP CHORD, BOTTOM CHORD, AND WEB PLANES. IN ADDITION TO THESE MINIMUM GUIDELINES, ALWAYS CONSULT THE PROJECT ARCHITECT OR ENGINEER FOR ADDITIONAL BRACING CONSIDERATIONS.

**LOAD CASE(S)** Standard

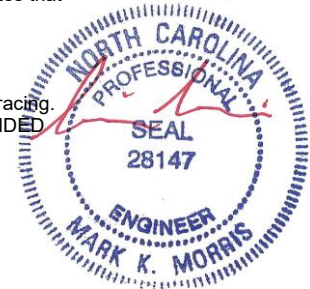

9/29/2021

**Warning !—Verify design parameters and read notes before use.** This design is based only upon parameters shown, and is for an individual building component to be installed and loaded vertically. Applicability of design parameters and proper incorporation of component is responsibility of building designer – not truss designer or truss engineer. Bracing shown is for lateral support of individual web members only. Additional temporary bracing to ensure stability during construction is the responsibility of the erector. Additional permanent bracing of the overall structure is the responsibility of the building designer. For general guidance regarding fabrication, quality control, storage, delivery, erection and bracing, consult ANSI/TPI 1 *National Design Standard for Metal Plate Connected Wood Truss Construction* and BCSI 1-03 *Guide to Good Practice for Handling, Installing & Bracing of Metal Plate Connected Wood Trusses* from Truss Plate Institute, 583 D\*Onofrio Drive, Madison, WI 53719.

Job 21-5120-R01	Truss VT07	Truss Type Valley	Qty 1	Ply 1	LOT 17 VILLAS @ ANDERSON CREEK   66 HAWK RIDGE DRIVE SPRING LAKE, NC # 28709
--------------------	---------------	----------------------	----------	----------	---

ID: xwDXRRIPWwRqwmU1uH5\_sXuyd8cO-X74Q2zKkV3MG1kbHPOJKYDxC9YdPybkrhmj5YyYPeN  
8.430 s Feb 12 2021 MiTek Industries, Inc. Thu Sep 30 15:45:42 2021 Page 1

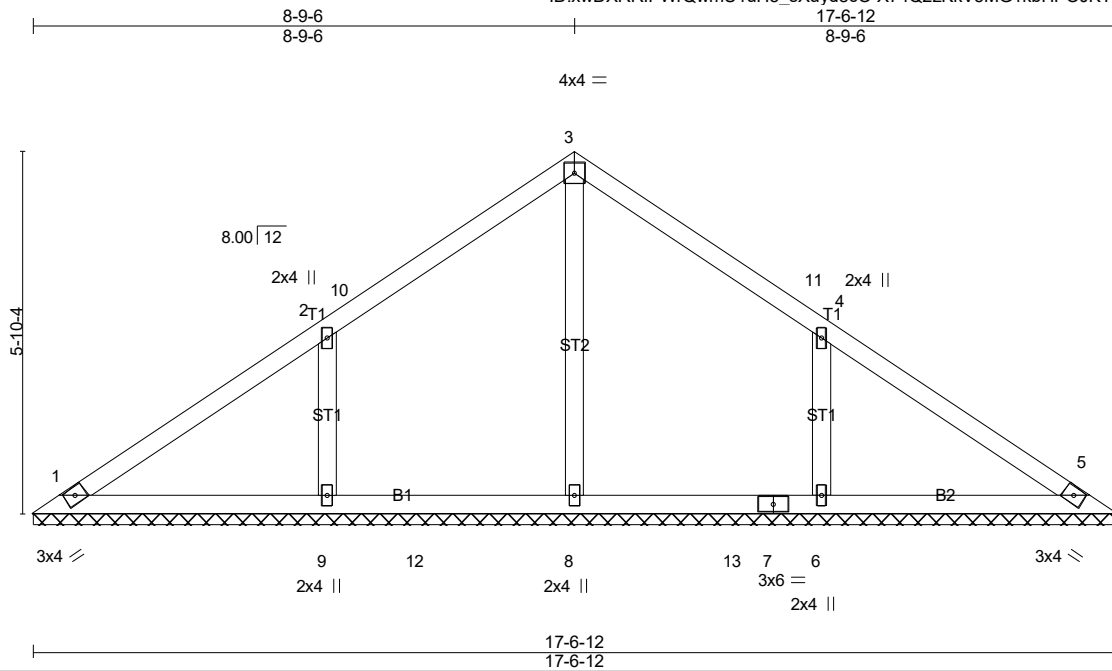

Scale = 1:37.3

<b>LOADING</b> (psf)	<b>SPACING-</b>	<b>CSI.</b>	<b>DEFL.</b>	<b>PLATES</b>	<b>GRIP</b>
TCLL (roof) 20.0	2-0-0	TC 0.24	in (loc) l/defl L/d	MT20	244/190
Snow (Pf) 20.0	Plate Grip DOL 1.15	BC 0.35	Vert(LL) n/a - n/a 999		
TCDL 10.0	Lumber DOL 1.15	WB 0.10	Vert(CT) n/a - n/a 999		
BCLL 0.0 *	Rep Stress Incr YES	Matrix-SH	Horz(CT) 0.00 5 n/a n/a		
BCDL 10.0	Code IRC2018/TPI2014			Weight: 72 lb	FT = 20%

**LUMBER-**  
TOP CHORD 2x4 SP No.2  
BOT CHORD 2x4 SP No.3  
OTHERS 2x4 SP No.3

**BRACING-**  
TOP CHORD  
BOT CHORD

Structural wood sheathing directly applied or 6-0-0 oc purlins.  
Rigid ceiling directly applied or 10-0-0 oc bracing.

MiTek recommends that Stabilizers and required cross bracing be installed during truss erection, in accordance with Stabilizer Installation guide.

**REACTIONS.** All bearings 17-6-12.  
(lb) - Max Horz 1=-127(LC 8)  
Max Uplift All uplift 100 lb or less at joint(s) 1 except 9=-162(LC 12), 6=-162(LC 13)  
Max Grav All reactions 250 lb or less at joint(s) 1, 5 except 8=403(LC 19), 9=446(LC 19), 6=446(LC 20)

**FORCES.** (lb) - Max. Comp./Max. Ten. - All forces 250 (lb) or less except when shown.  
**WEBS** 2-9=-306/194, 4-6=-306/194

**NOTES-** (9-12)

- Unbalanced roof live loads have been considered for this design.
- Wind: ASCE 7-16; Vult=130mph (3-second gust) Vasd=103mph; TCCL=5.0psf; BCDL=5.0psf; h=23ft; Cat. II; Exp B; Enclosed; MWFRS (envelope) gable end zone and C-C Exterior(2E) 0-5-12 to 5-3-6, Exterior(2R) 5-3-6 to 12-3-6, Exterior(2E) 12-3-6 to 17-1-0 zone; C-C for members and forces & MWFRS for reactions shown; Lumber DOL=1.60 plate grip DOL=1.60
- TCCL: ASCE 7-16; Pr=20.0 psf (roof LL: Lum DOL=1.15 Plate DOL=1.15); Pf=20.0 psf (Lum DOL=1.15 Plate DOL=1.15); Is=1.0; Rough Cat B; Partially Exp.; Ce=1.0; Cs=1.00; Ct=1.10
- Gable requires continuous bottom chord bearing.
- This truss has been designed for a 10.0 psf bottom chord live load nonconcurrent with any other live loads.
- \* This truss has been designed for a live load of 30.0psf on the bottom chord in all areas where a rectangle 3-6-0 tall by 1-0-0 wide will fit between the bottom chord and any other members, with BCDL = 10.0psf.
- Provide mechanical connection (by others) of truss to bearing plate capable of withstanding 100 lb uplift at joint(s) 1 except (jt=lb) 9=162, 6=162.
- This truss is designed in accordance with the 2018 International Residential Code sections R502.11.1 and R802.10.2 and referenced standard ANSI/TPI 1.
- Graphical bracing representation does not depict the size, type or the orientation of the brace on the member. Symbol only indicates that the member must be braced.
- Bearing symbols are only graphical representations of a possible bearing condition. Bearing symbols are not considered in the structural design of the truss to support the loads indicated.
- Web bracing shown is for lateral support of individual web members only. Refer to BCSI - Guide to Good Practice for Handling, Installing, Restraining & Bracing of Metal Plate Connected Wood Trusses for additional bracing guidelines, including diagonal bracing.
- SEE BCSI-B3 SUMMARY SHEET- PERMANENT RESTRAINING/BRACING OF CHORDS & WEB MEMBERS FOR RECOMMENDED MINIMUM BRACING REQUIREMENTS OF TOP CHORD, BOTTOM CHORD, AND WEB PLANES. IN ADDITION TO THESE MINIMUM GUIDELINES, ALWAYS CONSULT THE PROJECT ARCHITECT OR ENGINEER FOR ADDITIONAL BRACING CONSIDERATIONS.

**LOAD CASE(S)** Standard

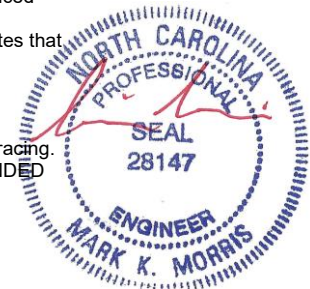

9/29/2021

**Warning !—Verify design parameters and read notes before use.** This design is based only upon parameters shown, and is for an individual building component to be installed and loaded vertically. Applicability of design parameters and proper incorporation of component is responsibility of building designer – not truss designer or truss engineer. Bracing shown is for lateral support of individual web members only. Additional temporary bracing to ensure stability during construction is the responsibility of the erector. Additional permanent bracing of the overall structure is the responsibility of the building designer. For general guidance regarding fabrication, quality control, storage, delivery, erection and bracing, consult ANSI/TPI 1 *National Design Standard for Metal Plate Connected Wood Truss Construction* and BCSI 1-03 *Guide to Good Practice for Handling, Installing & Bracing of Metal Plate Connected Wood Trusses* from Truss Plate Institute, 583 D'Onofrio Drive, Madison, WI 53719.

Job	Truss	Truss Type	Qty	Ply	LOT 17 VILLAS @ ANDERSON CREEK   66 HAWK RIDGE DRIVE SPRING LAKE, NC
21-5120-R01	VT08	Valley	1	1	Job Reference (optional) # 28709

ID: xwDXRRIPWwRqwmU1uH5\_sXuyd8cO-?JeoGJLMGnu7euAUz6qZ5RUOuy?th2U\_vVVGd\_yYPeM  
 8.430 s Feb 12 2021 MiTek Industries, Inc. Thu Sep 30 15:45:43 2021 Page 1

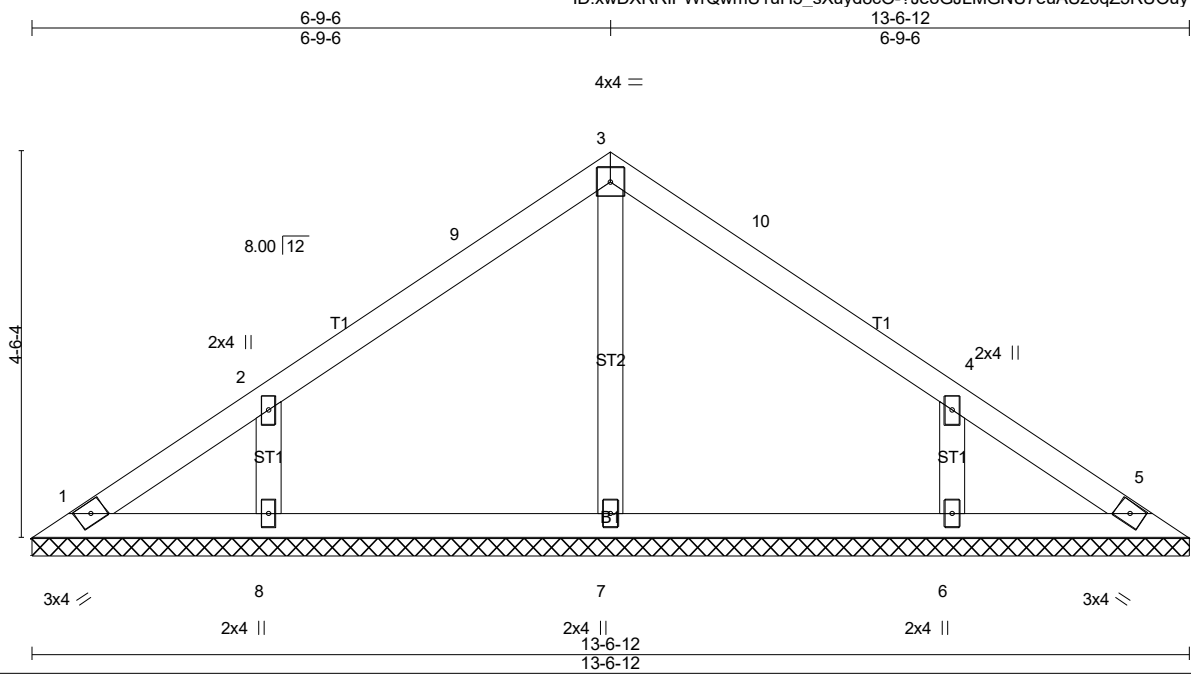

Scale = 1:27.0

<b>LOADING</b> (psf)	<b>SPACING-</b>	<b>CSI.</b>	<b>DEFL.</b>	<b>PLATES</b>	<b>GRIP</b>
TCLL (roof) 20.0	2-0-0	TC 0.17	in (loc) l/defl L/d	MT20	244/190
Snow (Pf) 20.0	Plate Grip DOL 1.15	BC 0.20	Vert(LL) n/a - n/a 999		
TCDL 10.0	Lumber DOL 1.15	WB 0.07	Vert(CT) n/a - n/a 999		
BCLL 0.0 *	Rep Stress Incr YES	Matrix-SH	Horz(CT) 0.00 5 n/a n/a		
BCDL 10.0	Code IRC2018/TPI2014			Weight: 52 lb	FT = 20%

**LUMBER-**  
 TOP CHORD 2x4 SP No.2  
 BOT CHORD 2x4 SP No.3  
 OTHERS 2x4 SP No.3

**BRACING-**  
 TOP CHORD Structural wood sheathing directly applied or 6'-0-0 oc purlins.  
 BOT CHORD Rigid ceiling directly applied or 10'-0-0 oc bracing.

MiTek recommends that Stabilizers and required cross bracing be installed during truss erection, in accordance with Stabilizer Installation guide.

**REACTIONS.** All bearings 13-6-12.  
 (lb) - Max Horz 1=-96(LC 8)  
 Max Uplift All uplift 100 lb or less at joint(s) 1 except 8=-128(LC 12), 6=-128(LC 13)  
 Max Grav All reactions 250 lb or less at joint(s) 1, 5 except 7=266(LC 1), 8=319(LC 19), 6=318(LC 20)

**FORCES.** (lb) - Max. Comp./Max. Ten. - All forces 250 (lb) or less except when shown.

- NOTES-** (9-12)
- Unbalanced roof live loads have been considered for this design.
  - Wind: ASCE 7-16; Vult=130mph (3-second gust) Vasd=103mph; TCDL=5.0psf; BCDL=5.0psf; h=23ft; Cat. II; Exp B; Enclosed; MWFRS (envelope) gable end zone and C-C Exterior(2E) 0-5-12 to 5-3-6, Exterior(2R) 5-3-6 to 8-3-6, Exterior(2E) 8-3-6 to 13-1-0 zone; C-C for members and forces & MWFRS for reactions shown; Lumber DOL=1.60 plate grip DOL=1.60
  - TCLL: ASCE 7-16; Pr=20.0 psf (roof LL: Lum DOL=1.15 Plate DOL=1.15); Pf=20.0 psf (Lum DOL=1.15 Plate DOL=1.15); Is=1.0; Rough Cat B; Partially Exp.; Ce=1.0; Cs=1.00; Ct=1.10
  - Gable requires continuous bottom chord bearing.
  - This truss has been designed for a 10.0 psf bottom chord live load nonconcurrent with any other live loads.
  - \* This truss has been designed for a live load of 30.0psf on the bottom chord in all areas where a rectangle 3-6-0 tall by 1-0-0 wide will fit between the bottom chord and any other members.
  - Provide mechanical connection (by others) of truss to bearing plate capable of withstanding 100 lb uplift at joint(s) 1 except (jt=lb) 8=128, 6=128.
  - This truss is designed in accordance with the 2018 International Residential Code sections R502.11.1 and R802.10.2 and referenced standard ANSI/TPI 1.
  - Graphical bracing representation does not depict the size, type or the orientation of the brace on the member. Symbol only indicates that the member must be braced.
  - Bearing symbols are only graphical representations of a possible bearing condition. Bearing symbols are not considered in the structural design of the truss to support the loads indicated.
  - Web bracing shown is for lateral support of individual web members only. Refer to BCSI - Guide to Good Practice for Handling, Installing, Restraining & Bracing of Metal Plate Connected Wood Trusses for additional bracing guidelines, including diagonal bracing.
  - SEE BCSI-B3 SUMMARY SHEET- PERMANENT RESTRAINING/BRACING OF CHORDS & WEB MEMBERS FOR RECOMMENDED MINIMUM BRACING REQUIREMENTS OF TOP CHORD, BOTTOM CHORD, AND WEB PLANES. IN ADDITION TO THESE MINIMUM GUIDELINES, ALWAYS CONSULT THE PROJECT ARCHITECT OR ENGINEER FOR ADDITIONAL BRACING CONSIDERATIONS.

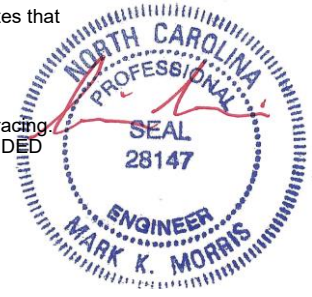

9/29/2021

**Warning !—Verify design parameters and read notes before use.** This design is based only upon parameters shown, and is for an individual building component to be installed and loaded vertically. Applicability of design parameters and proper incorporation of component is responsibility of building designer – not truss designer or truss engineer. Bracing shown is for lateral support of individual web members only. Additional temporary bracing to ensure stability during construction is the responsibility of the erector. Additional permanent bracing of the overall structure is the responsibility of the building designer. For general guidance regarding fabrication, quality control, storage, delivery, erection and bracing, consult ANSI/TPI 1 *National Design Standard for Metal Plate Connected Wood Truss Construction* and BCSI 1-03 *Guide to Good Practice for Handling, Installing & Bracing of Metal Plate Connected Wood Trusses* from Truss Plate Institute, 583 D'Onofrio Drive, Madison, WI 53719.

Job 21-5120-R01	Truss VT09	Truss Type Valley	Qty 1	Ply 1	LOT 17 VILLAS @ ANDERSON CREEK   66 HAWK RIDGE DRIVE SPRING LAKE, Job Reference (optional) # 28709
--------------------	---------------	----------------------	----------	----------	---

8.430 s Feb 12 2021 MiTek Industries, Inc. Thu Sep 30 15:45:45 2021 Page 1  
ID:xwDXRRIPWrQwmU1uH5\_sXuyd8cO-xhmYh?Mco\_kruBKs4Ws1AsZjSmgj9zDHNp\_NityYPeK

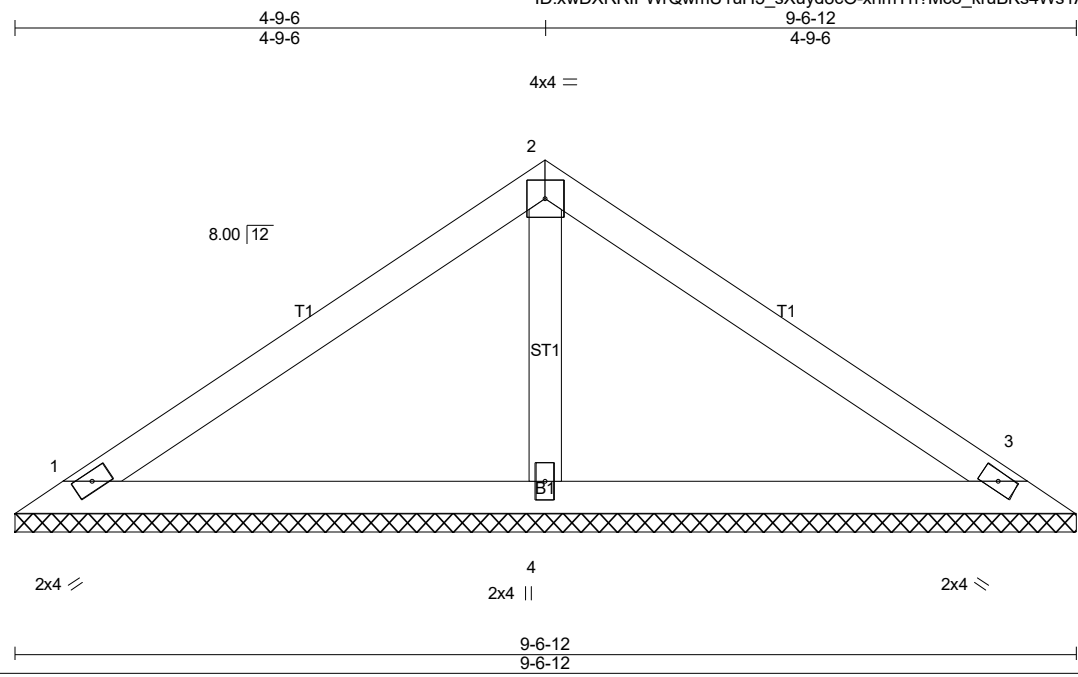

Scale = 1:20.8

<b>LOADING</b> (psf)	<b>SPACING-</b>	<b>CSI.</b>	<b>DEFL.</b>	<b>PLATES</b>	<b>GRIP</b>
TCLL (roof) 20.0	2-0-0	TC 0.23	in (loc) l/defl L/d	MT20	244/190
Snow (Pf) 20.0	Plate Grip DOL 1.15	BC 0.31	Vert(LL) n/a - n/a 999		
TCDL 10.0	Lumber DOL 1.15	WB 0.05	Vert(CT) n/a - n/a 999		
BCLL 0.0 *	Rep Stress Incr YES	Matrix-SH	Horz(CT) 0.00 3 n/a n/a		
BCDL 10.0	Code IRC2018/TPI2014			Weight: 34 lb	FT = 20%

**LUMBER-**  
TOP CHORD 2x4 SP No.2  
BOT CHORD 2x4 SP No.3  
OTHERS 2x4 SP No.3

**BRACING-**  
TOP CHORD Structural wood sheathing directly applied or 6-0-0 oc purlins.  
BOT CHORD Rigid ceiling directly applied or 10-0-0 oc bracing.

MiTek recommends that Stabilizers and required cross bracing be installed during truss erection, in accordance with Stabilizer Installation guide.

**REACTIONS.** (lb/size) 1=165/9-6-12 (min. 0-1-8), 3=165/9-6-12 (min. 0-1-8), 4=358/9-6-12 (min. 0-1-8)  
Max Horz 1=-66(LC 8)  
Max Uplift1=-31(LC 12), 3=-40(LC 13), 4=-27(LC 12)

**FORCES.** (lb) - Max. Comp./Max. Ten. - All forces 250 (lb) or less except when shown.

- NOTES-** (9-12)
- Unbalanced roof live loads have been considered for this design.
  - Wind: ASCE 7-16; Vult=130mph (3-second gust) Vasd=103mph; TCDL=5.0psf; BCDL=5.0psf; h=23ft; Cat. II; Exp B; Enclosed; MWFRS (envelope) gable end zone and C-C Exterior(2E) zone;C-C for members and forces & MWFRS for reactions shown; Lumber DOL=1.60 plate grip DOL=1.60
  - TCLL: ASCE 7-16; Pr=20.0 psf (roof LL: Lum DOL=1.15 Plate DOL=1.15); Pf=20.0 psf (Lum DOL=1.15 Plate DOL=1.15); Is=1.0; Rough Cat B; Partially Exp.; Ce=1.0; Cs=1.00; Ct=1.10
  - Gable requires continuous bottom chord bearing.
  - This truss has been designed for a 10.0 psf bottom chord live load nonconcurrent with any other live loads.
  - \* This truss has been designed for a live load of 30.0psf on the bottom chord in all areas where a rectangle 3-6-0 tall by 1-0-0 wide will fit between the bottom chord and any other members.
  - Provide mechanical connection (by others) of truss to bearing plate capable of withstanding 100 lb uplift at joint(s) 1, 3, 4.
  - This truss is designed in accordance with the 2018 International Residential Code sections R502.11.1 and R802.10.2 and referenced standard ANSI/TPI 1.
  - Graphical bracing representation does not depict the size, type or the orientation of the brace on the member. Symbol only indicates that the member must be braced.
  - Bearing symbols are only graphical representations of a possible bearing condition. Bearing symbols are not considered in the structural design of the truss to support the loads indicated.
  - Web bracing shown is for lateral support of individual web members only. Refer to BCSI - Guide to Good Practice for Handling, Installing, Restraining & Bracing of Metal Plate Connected Wood Trusses for additional bracing guidelines, including diagonal bracing.
  - SEE BCSI-B3 SUMMARY SHEET- PERMANENT RESTRAINING/BRACING OF CHORDS & WEB MEMBERS FOR RECOMMENDED MINIMUM BRACING REQUIREMENTS OF TOP CHORD, BOTTOM CHORD, AND WEB PLANES. IN ADDITION TO THESE MINIMUM GUIDELINES, ALWAYS CONSULT THE PROJECT ARCHITECT OR ENGINEER FOR ADDITIONAL BRACING CONSIDERATIONS.

**LOAD CASE(S)** Standard

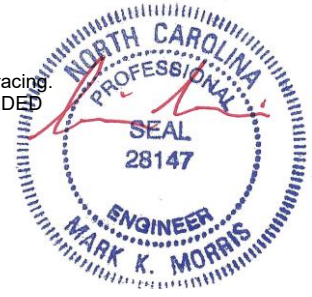

9/29/2021

**Warning !—Verify design parameters and read notes before use.** This design is based only upon parameters shown, and is for an individual building component to be installed and loaded vertically. Applicability of design parameters and proper incorporation of component is responsibility of building designer – not truss designer or truss engineer. Bracing shown is for lateral support of individual web members only. Additional temporary bracing to ensure stability during construction is the responsibility of the erector. Additional permanent bracing of the overall structure is the responsibility of the building designer. For general guidance regarding fabrication, quality control, storage, delivery, erection and bracing, consult ANSI/TPI 1 *National Design Standard for Metal Plate Connected Wood Truss Construction* and BCSI 1-03 *Guide to Good Practice for Handling, Installing & Bracing of Metal Plate Connected Wood Trusses* from Truss Plate Institute, 583 D'Onofrio Drive, Madison, WI 53719.



Job	Truss	Truss Type	Qty	Ply	LOT 17 VILLAS @ ANDERSON CREEK   66 HAWK RIDGE DRIVE SPRING LAKE, NC
21-5120-R01	VT10	Valley	1	1	Job Reference (optional) # 28709

8.430 s Feb 12 2021 MiTek Industries, Inc. Thu Sep 30 15:45:46 2021 Page 1

ID:xwDXRRIPWrQwmU1uH5\_sXuyd8cO-PuJwuLNFZlshVLv3eENGi36wO9zjuQGRcTkWEJyYPeJ

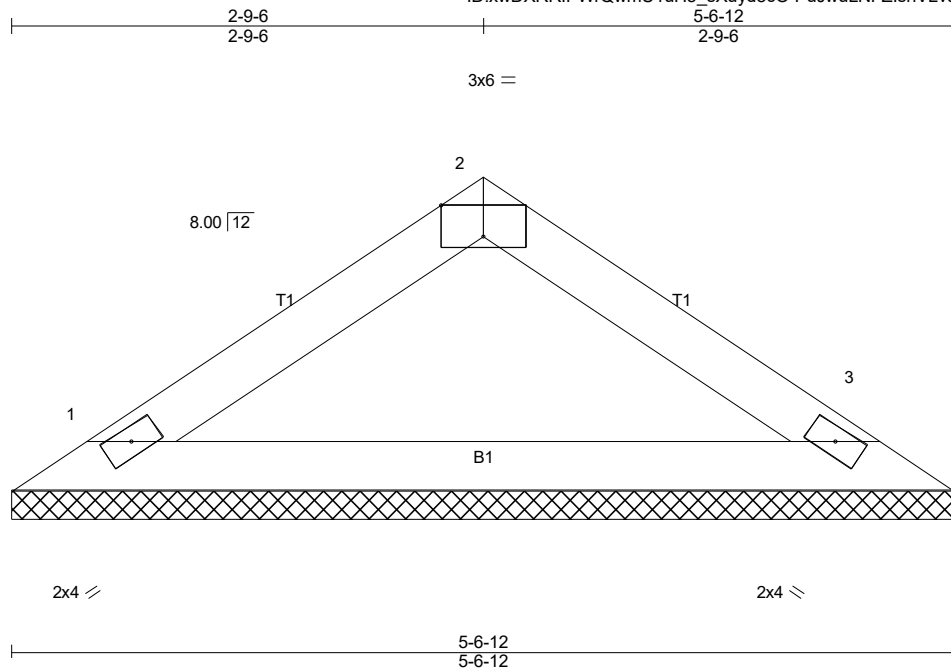

Scale = 1:13.6

Plate Offsets (X,Y)-- [2:0-3-0,Edge]		SPACING-		CSI.		DEFL.				PLATES	GRIP
LOADING (psf)		2-0-0		TC	0.09	in	(loc)	l/defl	L/d	MT20	244/190
TCLL (roof)	20.0	Plate Grip DOL	1.15	BC	0.45	Vert(LL)	n/a	-	n/a		
Snow (Pf)	20.0	Lumber DOL	1.15	WB	0.00	Vert(CT)	n/a	-	n/a		
TCDL	10.0	Rep Stress Incr	YES	Matrix-P		Horz(CT)	0.00	3	n/a		
BCLL	0.0 *	Code IRC2018/TPI2014								Weight: 17 lb	FT = 20%
BCDL	10.0										

**LUMBER-**  
 TOP CHORD 2x4 SP No.2  
 BOT CHORD 2x4 SP No.3

**BRACING-**  
 TOP CHORD Structural wood sheathing directly applied or 5-6-12 oc purlins.  
 BOT CHORD Rigid ceiling directly applied or 10-0-0 oc bracing.

MiTek recommends that Stabilizers and required cross bracing be installed during truss erection, in accordance with Stabilizer Installation guide.

**REACTIONS.** (lb/size) 1=184/5-6-12 (min. 0-1-8), 3=184/5-6-12 (min. 0-1-8)  
 Max Horz 1=35(LC 9)  
 Max Uplift 1=-24(LC 12), 3=-24(LC 13)

**FORCES.** (lb) - Max. Comp./Max. Ten. - All forces 250 (lb) or less except when shown.

- NOTES-** (9-12)
- Unbalanced roof live loads have been considered for this design.
  - Wind: ASCE 7-16; Vult=130mph (3-second gust) Vasd=103mph; TCDL=5.0psf; BCDL=5.0psf; h=23ft; Cat. II; Exp B; Enclosed; MWFRS (envelope) gable end zone and C-C Exterior(2E) zone; C-C for members and forces & MWFRS for reactions shown; Lumber DOL=1.60 plate grip DOL=1.60
  - TCLL: ASCE 7-16; Pr=20.0 psf (roof LL: Lum DOL=1.15 Plate DOL=1.15); Pf=20.0 psf (Lum DOL=1.15 Plate DOL=1.15); Is=1.0; Rough Cat B; Partially Exp.; Ce=1.0; Cs=1.00; Ct=1.10
  - Gable requires continuous bottom chord bearing.
  - This truss has been designed for a 10.0 psf bottom chord live load nonconcurrent with any other live loads.
  - \* This truss has been designed for a live load of 30.0psf on the bottom chord in all areas where a rectangle 3-6-0 tall by 1-0-0 wide will fit between the bottom chord and any other members.
  - Provide mechanical connection (by others) of truss to bearing plate capable of withstanding 100 lb uplift at joint(s) 1, 3.
  - This truss is designed in accordance with the 2018 International Residential Code sections R502.11.1 and R802.10.2 and referenced standard ANSI/TPI 1.
  - Graphical bracing representation does not depict the size, type or the orientation of the brace on the member. Symbol only indicates that the member must be braced.
  - Bearing symbols are only graphical representations of a possible bearing condition. Bearing symbols are not considered in the structural design of the truss to support the loads indicated.
  - Web bracing shown is for lateral support of individual web members only. Refer to BCSI - Guide to Good Practice for Handling, Installing, Restraining & Bracing of Metal Plate Connected Wood Trusses for additional bracing guidelines, including diagonal bracing.
  - SEE BCSI-B3 SUMMARY SHEET- PERMANENT RESTRAINING/BRACING OF CHORDS & WEB MEMBERS FOR RECOMMENDED MINIMUM BRACING REQUIREMENTS OF TOP CHORD, BOTTOM CHORD, AND WEB PLANES. IN ADDITION TO THESE MINIMUM GUIDELINES, ALWAYS CONSULT THE PROJECT ARCHITECT OR ENGINEER FOR ADDITIONAL BRACING CONSIDERATIONS.

**LOAD CASE(S)** Standard

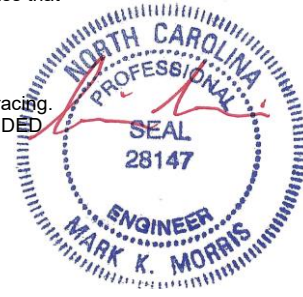

9/29/2021

**Warning !—Verify design parameters and read notes before use.** This design is based only upon parameters shown, and is for an individual building component to be installed and loaded vertically. Applicability of design parameters and proper incorporation of component is responsibility of building designer – not truss designer or truss engineer. Bracing shown is for lateral support of individual web members only. Additional temporary bracing to ensure stability during construction is the responsibility of the erector. Additional permanent bracing of the overall structure is the responsibility of the building designer. For general guidance regarding fabrication, quality control, storage, delivery, erection and bracing, consult ANSI/TPI 1 *National Design Standard for Metal Plate Connected Wood Truss Construction* and BCSI 1-03 *Guide to Good Practice for Handling, Installing & Bracing of Metal Plate Connected Wood Trusses* from Truss Plate Institute, 583 D'Onofrio Drive, Madison, WI 53719.