

**Trenco**

818 Soundside Rd  
Edenton, NC 27932

Re: 26304  
JAMES DREWRY

The truss drawing(s) referenced below have been prepared by Truss Engineering Co. under my direct supervision based on the parameters provided by C & R Truss.

Pages or sheets covered by this seal: I48578558 thru I48578570

My license renewal date for the state of North Carolina is December 31, 2021.

North Carolina COA: C-0844



October 30, 2021

Sevier, Scott

**IMPORTANT NOTE:** The seal on these truss component designs is a certification that the engineer named is licensed in the jurisdiction(s) identified and that the designs comply with ANSI/TPI 1. These designs are based upon parameters shown (e.g., loads, supports, dimensions, shapes and design codes), which were given to MiTek or TRENCO. Any project specific information included is for MiTek's or TRENCO's customers file reference purpose only, and was not taken into account in the preparation of these designs. MiTek or TRENCO has not independently verified the applicability of the design parameters or the designs for any particular building. Before use, the building designer should verify applicability of design parameters and properly incorporate these designs into the overall building design per ANSI/TPI 1, Chapter 2.



Scale = 1:77.0

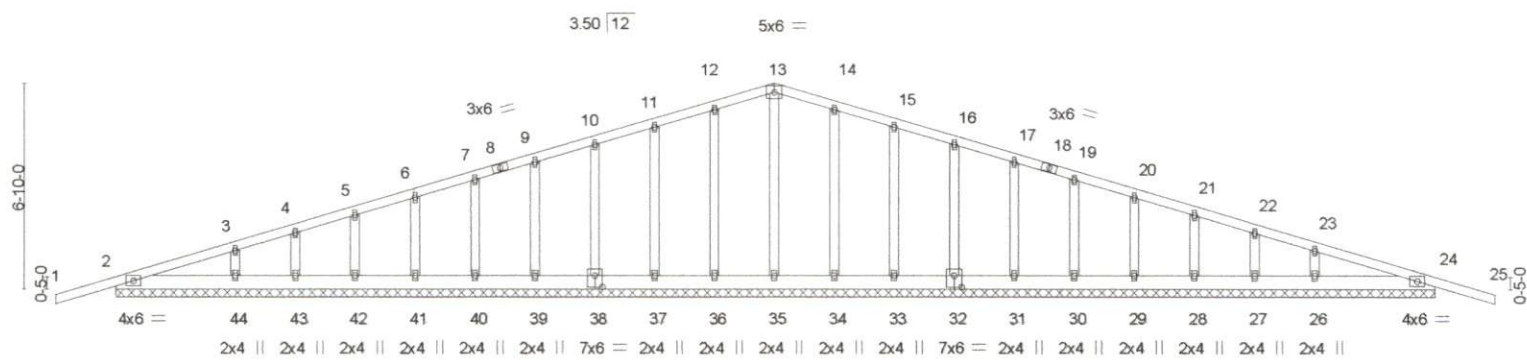

Plate Offsets (X,Y) - [32:0-3-0,0-4-8], [38:0-3-0,0-4-8]

LOADING (psf)	SPACING-	2-0-0	CSI.	DEFL.	in (loc)	l/defl	L/d	PLATES	GRIP
TCLL 20.0	Plate Grip DOL	1.15	TC 0.13	Vert(LL)	-0.01	25	n/r	MT20	244/190
TCDL 10.0	Lumber DOL	1.15	BC 0.02	Vert(CT)	-0.02	25	n/r		
BCLL 0.0 *	Rep Stress Incr	YES	WB 0.08	Horz(CT)	0.00	24	n/a		
BCDL 10.0	Code IRC2015/TPI2014		Matrix-S					Weight: 272 lb	FT = 20%

LUMBER-	BRACING-
TOP CHORD 2x4 SP 2400F 2.0E	TOP CHORD Structural wood sheathing directly applied or 6-0-0 oc purlins.
BOT CHORD 2x6 SP 2400F 2.0E	BOT CHORD Rigid ceiling directly applied or 10-0-0 oc bracing.
OTHERS 2x4 SP No.3	

**REACTIONS.** All bearings 44-0-0.  
 (lb) - Max Horz 2=81(LC 7)  
 Max Uplift All uplift 100 lb or less at joint(s) 2, 24, 36, 37, 38, 39, 40, 41, 42, 43, 34, 33, 32, 31, 30, 29, 28, 27  
 Max Grav All reactions 250 lb or less at joint(s) 35, 36, 37, 38, 39, 40, 41, 42, 43, 34, 33, 32, 31, 30, 29, 28, 27 except 2=293(LC 1), 24=293(LC 1), 44=261(LC 17), 26=261(LC 18)

**FORCES.** (lb) - Max. Comp./Max. Ten. - All forces 250 (lb) or less except when shown.

- NOTES-**
- Unbalanced roof live loads have been considered for this design.
  - Wind: ASCE 7-10; Vult=140mph Vasd=111mph; TCDL=6.0psf; BCDL=6.0psf; h=20ft; B=45ft; L=44ft; eave=2ft; Cat. II; Exp B; Enclosed; MWFRS (directional); cantilever left and right exposed; end vertical left and right exposed; Lumber DOL=1.60 plate grip DOL=1.60
  - Truss designed for wind loads in the plane of the truss only. For studs exposed to wind (normal to the face), see Standard Industry Gable End Details as applicable, or consult qualified building designer as per ANSI/TPI 1.
  - All plates are 1.5x4 MT20 unless otherwise indicated.
  - Gable requires continuous bottom chord bearing.
  - Gable studs spaced at 2-0-0 oc.
  - This truss has been designed for a 10.0 psf bottom chord live load nonconcurrent with any other live loads.
  - \* This truss has been designed for a live load of 20.0psf on the bottom chord in all areas with a clearance greater than 6-0-0 between the bottom chord and any other members, with BCDL = 10.0psf.
  - Provide mechanical connection (by others) of truss to bearing plate capable of withstanding 100 lb uplift at joint(s) 2, 24, 36, 37, 38, 39, 40, 41, 42, 43, 34, 33, 32, 31, 30, 29, 28, 27.

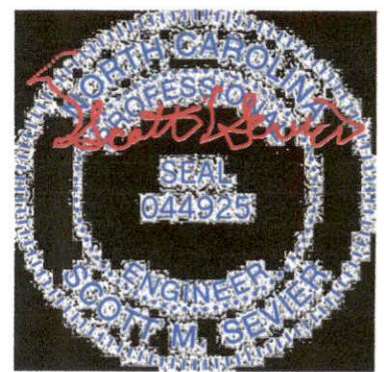

October 30, 2021



Scale = 1:40.1

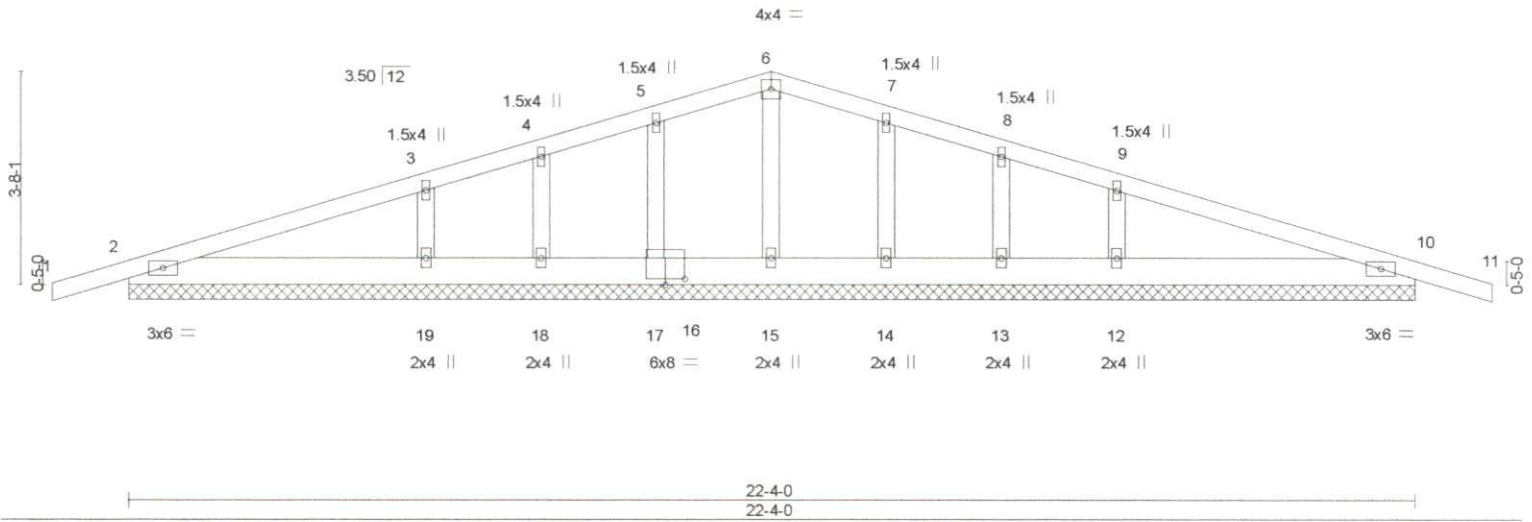

Plate Offsets (X,Y)-- [16-0-4-0,0-1-4]

LOADING (psf)	SPACING-	CSL	DEFL.	PLATES	GRIP
TCLL 20.0	2-0-0	TC 0.11	in (loc) l/defl L/d	MT20	244/190
TCDL 10.0	Plate Grip DOL 1.15	BC 0.07	Vert(LL) 0.00 11 n/r 120		
BCLL 0.0 *	Lumber DOL 1.15	WB 0.06	Vert(CT) 0.01 11 n/r 120		
BCDL 10.0	Rep Stress Incr YES	Matrix-S	Horz(CT) 0.00 10 n/a n/a		
	Code IRC2015/TPI2014			Weight: 111 lb	FT = 20%

**LUMBER-**  
 TOP CHORD 2x4 SP 2400F 2.0E  
 BOT CHORD 2x6 SP No.1  
 OTHERS 2x4 SP No.3

**BRACING-**  
 TOP CHORD Structural wood sheathing directly applied or 6-0-0 oc purlins.  
 BOT CHORD Rigid ceiling directly applied or 10-0-0 oc bracing.

**REACTIONS.** All bearings 22-4-0.  
 (lb) - Max Horz 2=41(LC 7)  
 Max Uplift All uplift 100 lb or less at joint(s) 2, 10, 17, 18, 19, 14, 13, 12  
 Max Grav All reactions 250 lb or less at joint(s) 15, 17, 18, 14, 13 except 2=263(LC 1), 10=263(LC 1), 19=412(LC 17), 12=412(LC 18)

**FORCES.** (lb) - Max. Comp./Max. Ten. - All forces 250 (lb) or less except when shown.  
 WEBS 3-19=-275/88, 9-12=-275/88

- NOTES-**
- Unbalanced roof live loads have been considered for this design.
  - Wind: ASCE 7-10; Vult=140mph Vasd=111mph; TCDL=6.0psf; BCDL=6.0psf; h=20ft; B=45ft; L=24ft; eave=2ft; Cat. II; Exp B; Enclosed, MWFRS (directional); cantilever left and right exposed; end vertical left and right exposed; Lumber DOL=1.60 plate grip DOL=1.60
  - Truss designed for wind loads in the plane of the truss only. For studs exposed to wind (normal to the face), see Standard Industry Gable End Details as applicable, or consult qualified building designer as per ANSI/TPI 1.
  - Gable requires continuous bottom chord bearing.
  - Gable studs spaced at 2-0-0 oc.
  - This truss has been designed for a 10.0 psf bottom chord live load nonconcurrent with any other live loads.
  - \* This truss has been designed for a live load of 20.0psf on the bottom chord in all areas with a clearance greater than 6-0-0 between the bottom chord and any other members.
  - Provide mechanical connection (by others) of truss to bearing plate capable of withstanding 100 lb uplift at joint(s) 2, 10, 17, 18, 19, 14, 13, 12.



October 30, 2021

**WARNING - Verify design parameters and READ NOTES ON THIS AND INCLUDED MITEK REFERENCE PAGE MII-7473 rev. 5/19/2020 BEFORE USE.**

Design valid for use only with MiTek® connectors. This design is based only upon parameters shown, and is for an individual building component, not a truss system. Before use, the building designer must verify the applicability of design parameters and properly incorporate this design into the overall building design. Bracing indicated is to prevent buckling of individual truss web and/or chord members only. Additional temporary and permanent bracing is always required for stability and to prevent collapse with possible personal injury and property damage. For general guidance regarding the





Scale = 1:77.0

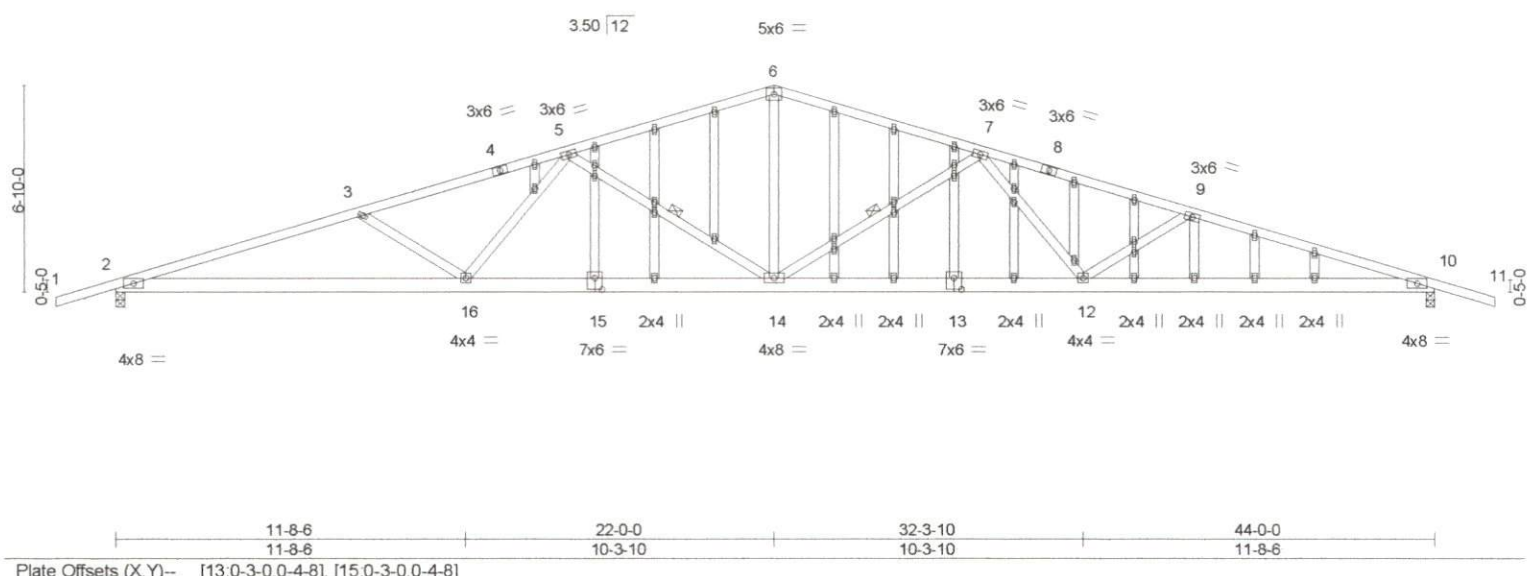

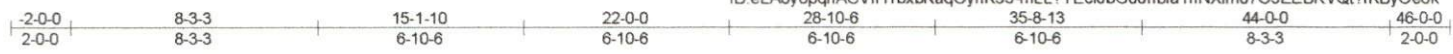

Scale = 1:77.0

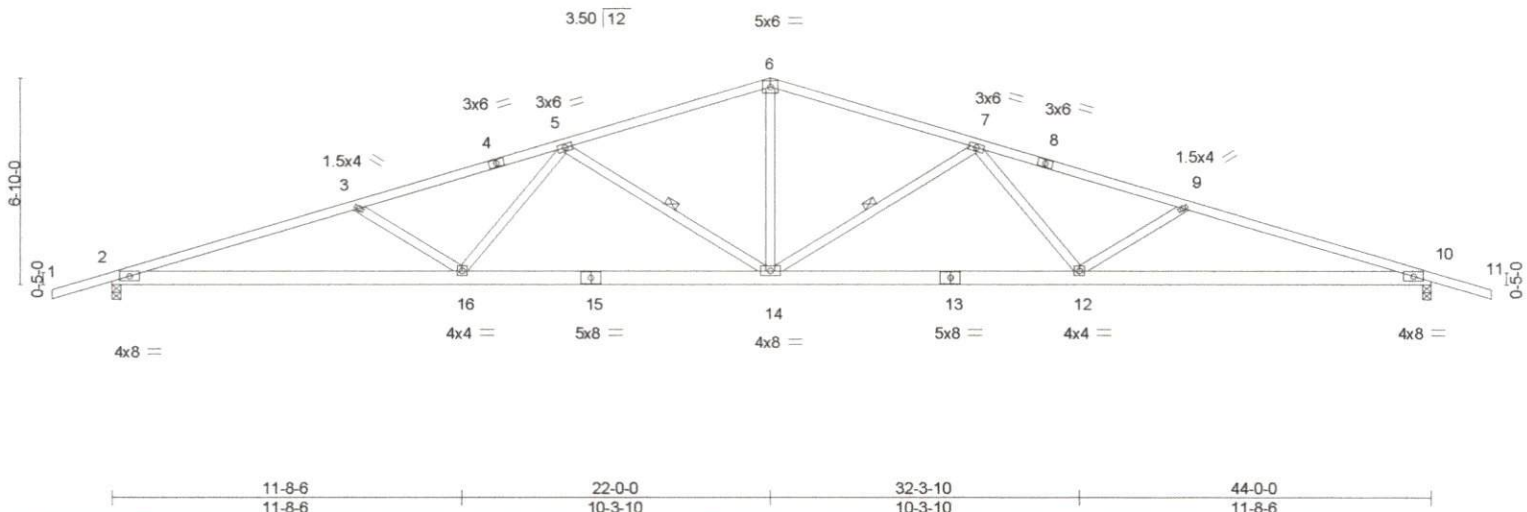

LOADING (psf)	SPACING-	CSL	DEFL.	PLATES	GRIP
TCLL 20.0	2-0-0	TC 0.41	in (loc) l/defl L/d	MT20	244/190
TCDL 10.0	Plate Grip DOL 1.15	BC 0.39	Vert(LL) -0.31 14 >999 360		
BCLL 0.0 *	Lumber DOL 1.15	WB 0.57	Vert(CT) -0.64 14-16 >830 240		
BCDL 10.0	Rep Stress Incr YES	Matrix-AS	Horz(CT) 0.13 10 n/a n/a		
	Code IRC2015/TPI2014		Wind(LL) 0.23 14 >999 240	Weight: 238 lb	FT = 20%

**LUMBER-**

TOP CHORD 2x4 SP 2400F 2.0E  
 BOT CHORD 2x6 SP 2400F 2.0E  
 WEBS 2x4 SP No.3

**BRACING-**

TOP CHORD Structural wood sheathing directly applied.  
 BOT CHORD Rigid ceiling directly applied.  
 WEBS 1 Row at midpt 7-14, 5-14

**REACTIONS.**

(size) 2=0-3-8, 10=0-3-8  
 Max Horz 2=-81(LC 6)  
 Max Uplift 2=-204(LC 8), 10=-204(LC 8)  
 Max Grav 2=1880(LC 1), 10=1880(LC 1)

**FORCES.**

(lb) - Max. Comp./Max. Ten. - All forces 250 (lb) or less except when shown.  
 TOP CHORD 2-3=-5059/424, 3-5=-4590/338, 5-6=-3221/307, 6-7=-3221/307, 7-9=-4590/338, 9-10=-5059/424  
 BOT CHORD 2-16=-327/4806, 14-16=-218/3933, 12-14=-218/3933, 10-12=-327/4806  
 WEBS 6-14=-49/1374, 7-14=-1093/150, 7-12=0/734, 9-12=-549/171, 5-14=-1093/150, 5-16=0/734, 3-16=-549/171

**NOTES-**

- 1) Unbalanced roof live loads have been considered for this design.
- 2) Wind: ASCE 7-10; Vult=140mph Vasd=111mph; TCDL=6.0psf; BCDL=6.0psf; h=20ft; B=45ft; L=44ft; eave=5ft; Cat. II; Exp B; Enclosed; MWFRS (directional); cantilever left and right exposed; end vertical left and right exposed; Lumber DOL=1.60 plate grip DOL=1.60
- 3) This truss has been designed for a 10.0 psf bottom chord live load nonconcurrent with any other live loads.
- 4) \* This truss has been designed for a live load of 20.0psf on the bottom chord in all areas with a clearance greater than 6-0-0 between the bottom chord and any other members.
- 5) Provide mechanical connection (by others) of truss to bearing plate capable of withstanding 100 lb uplift at joint(s) except (jt=lb) 2=204, 10=204.
- 6) This truss design requires that a minimum of 7/16" structural wood sheathing be applied directly to the top chord and 1/2" gypsum sheetrock be applied directly to the bottom chord.



October 30, 2021

**WARNING - Verify design parameters and READ NOTES ON THIS AND INCLUDED MITTEK REFERENCE PAGE MII-7473 rev. 5/19/2020 BEFORE USE.**  
 Design valid for use only with MiTek® connectors. This design is based only upon parameters shown, and is for an individual building component, not a truss system. Before use, the building designer must verify the applicability of design parameters and properly incorporate this design into the overall building design. Bracing indicated is to prevent buckling of individual truss web and/or chord members only. Additional temporary and permanent bracing is always required for stability and to prevent collapse with possible personal injury and property damage. For general guidance regarding the



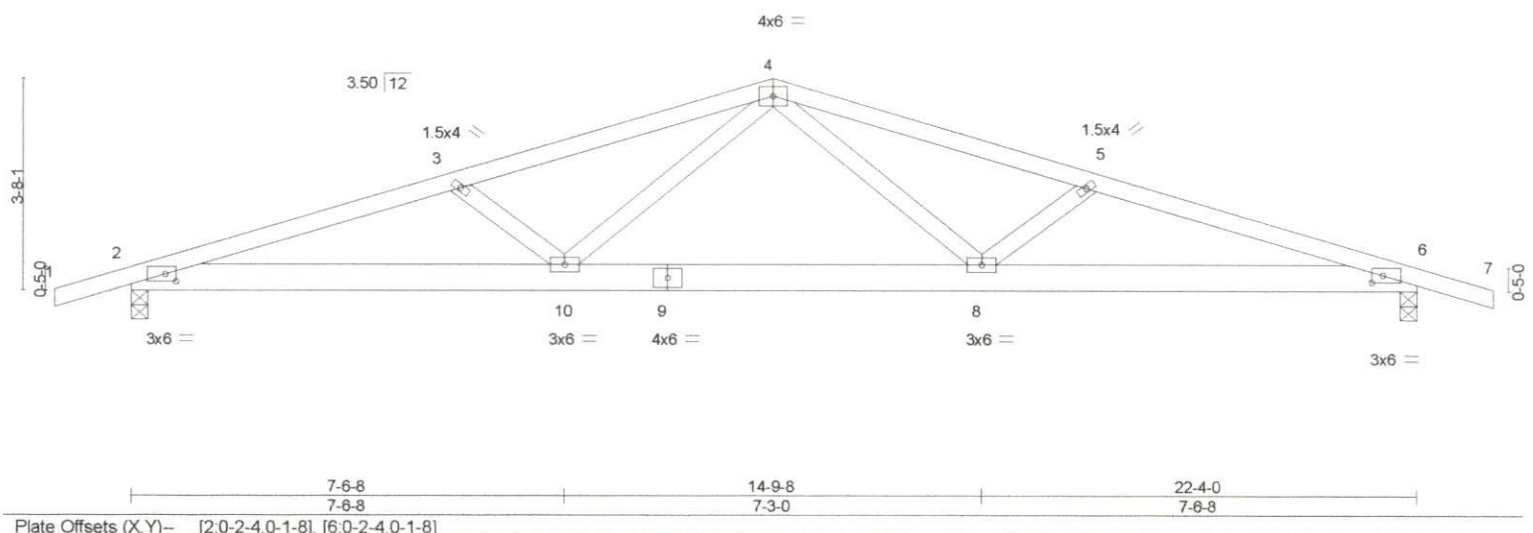

LOADING (psf)	SPACING-	CSI.	DEFL.	PLATES	GRIP
TCLL 20.0	2-0-0	TC 0.15	in (loc) l/defl L/d	MT20	244/190
TCDL 10.0	Plate Grip DOL 1.15	BC 0.34	Vert(LL) -0.08 8-10 >999 360		
BCLL 0.0 *	Lumber DOL 1.15	WB 0.26	Vert(CT) -0.18 8-10 >999 240		
BCDL 10.0	Rep Stress Incr YES	Matrix-AS	Horz(CT) 0.04 6 n/a n/a		
	Code IRC2015/TPI2014		Wind(LL) 0.06 8-10 >999 240	Weight: 112 lb	FT = 20%

**LUMBER-**  
 TOP CHORD 2x4 SP 2400F 2.0E  
 BOT CHORD 2x6 SP No.1  
 WEBS 2x4 SP No.3

**BRACING-**  
 TOP CHORD Structural wood sheathing directly applied.  
 BOT CHORD Rigid ceiling directly applied.

**REACTIONS.** (size) 2=0-3-8, 6=0-3-8  
 Max Horz 2=41(LC 7)  
 Max Uplift 2=-115(LC 8), 6=-115(LC 8)  
 Max Grav 2=973(LC 1), 6=973(LC 1)

**FORCES.** (lb) - Max. Comp./Max. Ten. - All forces 250 (lb) or less except when shown.  
 TOP CHORD 2-3=-2354/204, 3-4=-2083/156, 4-5=-2083/156, 5-6=-2354/204  
 BOT CHORD 2-10=-141/2238, 8-10=-60/1513, 6-8=-141/2238  
 WEBS 4-8=0/616, 5-8=-390/121, 4-10=0/616, 3-10=-390/121

- NOTES-**
- Unbalanced roof live loads have been considered for this design.
  - Wind: ASCE 7-10; Vult=140mph Vasd=111mph; TCDL=6.0psf; BCDL=6.0psf; h=20ft; B=45ft; L=24ft; eave=4ft; Cat. II; Exp B; Enclosed; MWFRS (directional); cantilever left and right exposed, end vertical left and right exposed; Lumber DOL=1.60 plate grip DOL=1.60
  - This truss has been designed for a 10.0 psf bottom chord live load nonconcurrent with any other live loads.
  - \* This truss has been designed for a live load of 20.0psf on the bottom chord in all areas with a clearance greater than 6-0-0 between the bottom chord and any other members.
  - Provide mechanical connection (by others) of truss to bearing plate capable of withstanding 100 lb uplift at joint(s) except (jt=lb) 2=115, 6=115.
  - This truss design requires that a minimum of 7/16" structural wood sheathing be applied directly to the top chord and 1/2" gypsum sheetrock be applied directly to the bottom chord.



October 30, 2021





Scale = 1:40.1

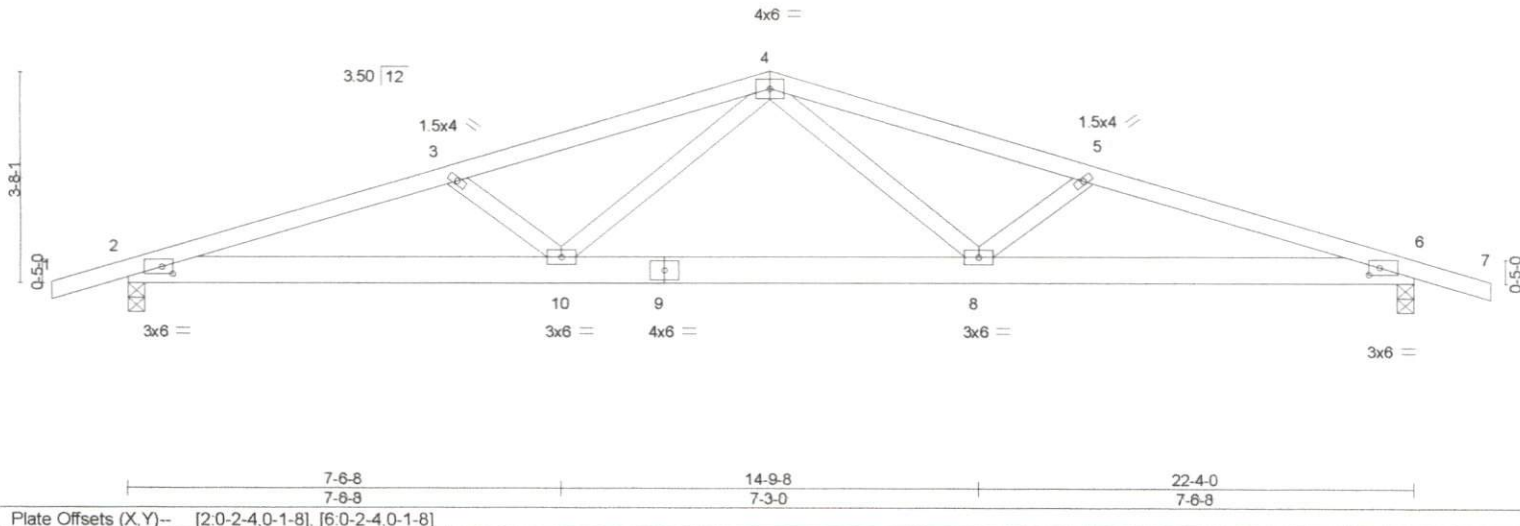

LOADING (psf)	SPACING-	CSI.	DEFL.	PLATES	GRIP
TCLL 20.0	Plate Grip DOL 1.15	TC 0.15	in (loc) l/defl L/d	MT20	244/190
TCDL 10.0	Lumber DOL 1.15	BC 0.34	Vert(LL) -0.08 8-10 >999 360		
BCLL 0.0 *	Rep Stress Incr YES	WB 0.26	Vert(CT) -0.18 8-10 >999 240		
BCDL 10.0	Code IRC2015/TPI2014	Matrix-AS	Horz(CT) 0.04 6 n/a n/a		
			Wind(LL) 0.06 8-10 >999 240	Weight: 112 lb	FT = 20%

LUMBER-	BRACING-
TOP CHORD 2x4 SP 2400F 2.0E	TOP CHORD Structural wood sheathing directly applied.
BOT CHORD 2x6 SP No.1	BOT CHORD Rigid ceiling directly applied.
WEBS 2x4 SP No.3	

**REACTIONS.** (size) 2=0-3-8, 6=0-3-8  
 Max Horz 2=41(LC 7)  
 Max Uplift 2=-115(LC 8), 6=-115(LC 8)  
 Max Grav 2=973(LC 1), 6=973(LC 1)

**FORCES.** (lb) - Max. Comp./Max. Ten. - All forces 250 (lb) or less except when shown.  
 TOP CHORD 2-3=-2354/204, 3-4=-2083/156, 4-5=-2083/156, 5-6=-2354/204  
 BOT CHORD 2-10=-141/2238, 8-10=-60/1513, 6-8=-141/2238  
 WEBS 4-8=0/616, 5-8=-390/121, 4-10=0/616, 3-10=-390/121

- NOTES-**
- Unbalanced roof live loads have been considered for this design.
  - Wind: ASCE 7-10; Vult=140mph Vasd=111mph; TCDL=6.0psf; BCDL=6.0psf; h=20ft; B=45ft; L=24ft; eave=4ft, Cat. II; Exp B; Enclosed; MWFRS (directional); cantilever left and right exposed; end vertical left and right exposed; Lumber DOL=1.60 plate grip DOL=1.60
  - This truss has been designed for a 10.0 psf bottom chord live load nonconcurrent with any other live loads.
  - \* This truss has been designed for a live load of 20.0psf on the bottom chord in all areas with a clearance greater than 6-0-0 between the bottom chord and any other members.
  - Provide mechanical connection (by others) of truss to bearing plate capable of withstanding 100 lb uplift at joint(s) except (jt=lb) 2=115, 6=115.
  - This truss design requires that a minimum of 7/16" structural wood sheathing be applied directly to the top chord and 1/2" gypsum sheetrock be applied directly to the bottom chord.



October 30, 2021

19-9-10  
19-9-10

39-7-4  
19-9-10

Scale = 1:63.3

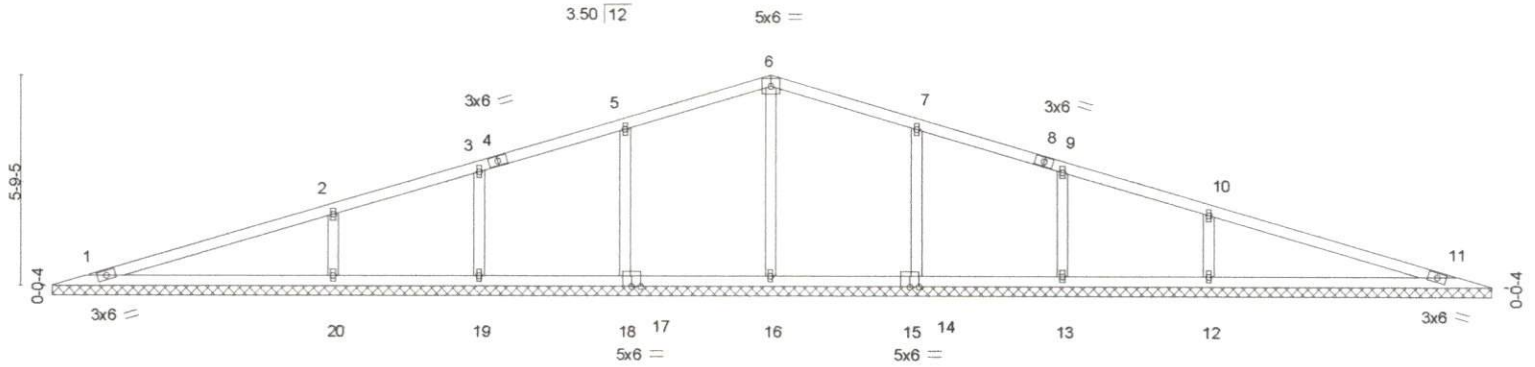

0-0-14 39-7-4  
0-0-14 39-6-7

LOADING (psf)	SPACING-	2-0-0	CSI.	DEFL.	in (loc)	l/defl	L/d	PLATES	GRIP	
TCLL 20.0	Plate Grip DOL	1.15	TC 0.58	Vert(LL)	n/a	-	n/a	999	MT20	244/190
TCDL 10.0	Lumber DOL	1.15	BC 0.37	Vert(CT)	n/a	-	n/a	999		
BCLL 0.0 *	Rep Stress Incr	YES	WB 0.12	Horz(CT)	0.00	11	n/a	n/a		
BCDL 10.0	Code	IRC2015/TPI2014	Matrix-S							
								Weight: 150 lb	FT = 20%	

**LUMBER-**  
TOP CHORD 2x4 SP No.2  
BOT CHORD 2x4 SP No.2  
OTHERS 2x4 SP No.3

**BRACING-**  
TOP CHORD Structural wood sheathing directly applied or 6-0-0 oc purlins.  
BOT CHORD Rigid ceiling directly applied or 10-0-0 oc bracing.

**REACTIONS.** All bearings 39-5-9.  
(lb) - Max Horz 1=-58(LC 6)  
Max Uplift All uplift 100 lb or less at joint(s) 1, 18, 19, 20, 14, 13, 12, 11  
Max Grav All reactions 250 lb or less at joint(s) 1, 19, 13, 11 except 16=280(LC 1), 18=365(LC 17), 20=552(LC 17), 14=365(LC 18), 12=552(LC 18)

**FORCES.** (lb) - Max. Comp./Max. Ten. - All forces 250 (lb) or less except when shown.  
WEBS 5-18=-276/93, 2-20=-400/132, 7-14=-276/93, 10-12=-400/132

- NOTES-**
- 1) Unbalanced roof live loads have been considered for this design.
  - 2) Wind: ASCE 7-10; Vult=140mph Vasd=111mph; TCCL=6.0psf, BCDL=6.0psf, h=20ft, B=45ft, L=39ft, eave=5ft, Cat. II; Exp B; Enclosed; MWFRS (directional); cantilever left and right exposed; end vertical left and right exposed; Lumber DOL=1.60 plate grip DOL=1.60
  - 3) All plates are 1.5x4 MT20 unless otherwise indicated.
  - 4) Gable requires continuous bottom chord bearing.
  - 5) This truss has been designed for a 10.0 psf bottom chord live load nonconcurrent with any other live loads.
  - 6) \* This truss has been designed for a live load of 20.0psf on the bottom chord in all areas with a clearance greater than 6-0-0 between the bottom chord and any other members.
  - 7) Provide mechanical connection (by others) of truss to bearing plate capable of withstanding 100 lb uplift at joint(s) 1, 18, 19, 20, 14, 13, 12, 11.

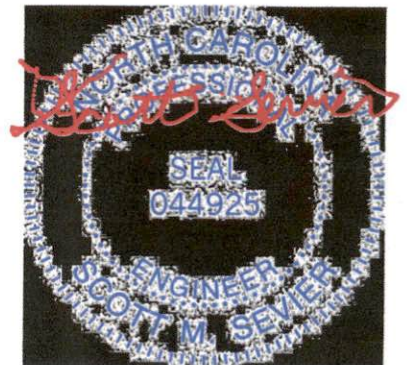

October 30, 2021

**WARNING - Verify design parameters and READ NOTES ON THIS AND INCLUDED MITEK REFERENCE PAGE MII-7473 rev. 5/19/2020 BEFORE USE.**  
Design valid for use only with MiTek® connectors. This design is based only upon parameters shown, and is for an individual building component, not a truss system. Before use, the building designer must verify the applicability of design parameters and properly incorporate this design into the overall building design. Bracing indicated is to prevent buckling of individual truss web and/or chord members only. Additional temporary and permanent bracing is always required for stability and to prevent collapse with possible personal injury and property damage. For general guidance regarding the





17-6-3 35-0-7  
17-6-3 17-6-3

Scale = 1:55.9

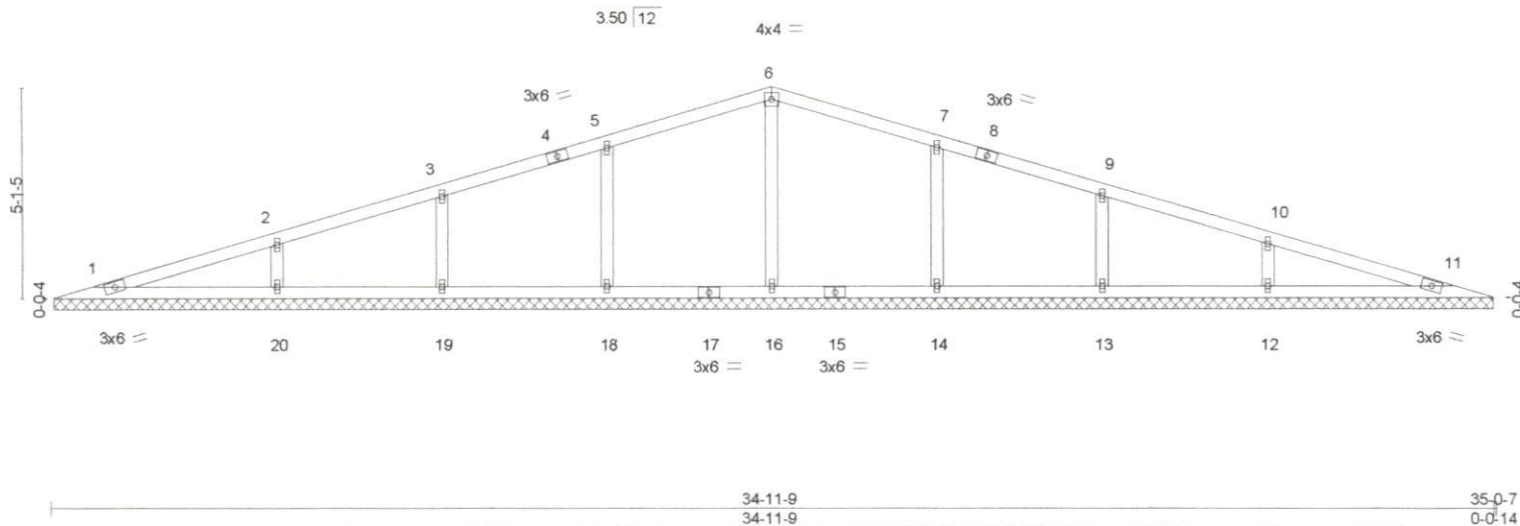

LOADING (psf)	SPACING-	CSI.	DEFL.	PLATES	GRIP
TCLL 20.0	2-0-0	TC 0.24	in (loc) l/defl L/d	MT20	244/190
TCDL 10.0	Plate Grip DOL 1.15	BC 0.15	Vert(LL) n/a - n/a 999		
BCLL 0.0 *	Lumber DOL 1.15	WB 0.10	Vert(CT) n/a - n/a 999		
BCDL 10.0	Rep Stress Incr YES	Matrix-S	Horz(CT) 0.00 11 n/a n/a		
	Code IRC2015/TPI2014			Weight: 129 lb	FT = 20%

**LUMBER-**  
TOP CHORD 2x4 SP No.2  
BOT CHORD 2x4 SP No.2  
OTHERS 2x4 SP No.3

**BRACING-**  
TOP CHORD Structural wood sheathing directly applied or 6-0-0 oc purlins.  
BOT CHORD Rigid ceiling directly applied or 10-0-0 oc bracing.

**REACTIONS.** All bearings 34-10-11.  
(lb) - Max Horz 1=-52(LC 6)  
Max Uplift All uplift 100 lb or less at joint(s) 1, 18, 19, 20, 14, 13, 12, 11  
Max Grav All reactions 250 lb or less at joint(s) 1, 11 except 16=289(LC 1), 18=346(LC 17), 19=296(LC 1), 20=390(LC 17), 14=346(LC 18), 13=296(LC 1), 12=390(LC 18)

**FORCES.** (lb) - Max. Comp./Max. Ten. - All forces 250 (lb) or less except when shown.  
WEBS 5-18=-264/89, 2-20=-286/96, 7-14=-264/89, 10-12=-286/96

- NOTES-**
- Unbalanced roof live loads have been considered for this design.
  - Wind: ASCE 7-10; Vult=140mph Vasd=111mph; TCDL=6.0psf; BCDL=6.0psf; h=20ft; B=45ft; L=35ft; eave=4ft; Cat. II; Exp B; Enclosed; MWFRS (directional); cantilever left and right exposed; end vertical left and right exposed; Lumber DOL=1.60 plate grip DOL=1.60
  - All plates are 1.5x4 MT20 unless otherwise indicated.
  - Gable requires continuous bottom chord bearing.
  - This truss has been designed for a 10.0 psf bottom chord live load nonconcurrent with any other live loads.
  - \* This truss has been designed for a live load of 20.0psf on the bottom chord in all areas with a clearance greater than 6-0-0 between the bottom chord and any other members.
  - Provide mechanical connection (by others) of truss to bearing plate capable of withstanding 100 lb uplift at joint(s) 1, 18, 19, 20, 14, 13, 12, 11.



October 30, 2021

**WARNING - Verify design parameters and READ NOTES ON THIS AND INCLUDED MITEK REFERENCE PAGE MII-7473 rev. 5/19/2020 BEFORE USE.**

Design valid for use only with MiTek® connectors. This design is based only upon parameters shown, and is for an individual building component, not a truss system. Before use, the building designer must verify the applicability of design parameters and properly incorporate this design into the overall building design. Bracing indicated is to prevent buckling of individual truss web and/or chord members only. Additional temporary and permanent bracing is always required for stability and to prevent collapse with possible personal injury and property damage. For general guidance regarding the





Scale = 1.48.6

0-0-14 0-0-14	30-5-9 30-4-11						
Plate Offsets (X, Y)-- [10-0-3-0,0-3-0]							
<b>LOADING</b> (psf)	<b>SPACING-</b>	2-0-0	<b>CSI.</b>	<b>DEFL.</b>	in (loc)	l/defl	L/d
TCLL 20.0	Plate Grip DOL	1.15	TC 0.48	Vert(LL)	n/a	-	n/a 999
TCDL 10.0	Lumber DOL	1.15	BC 0.31	Vert(CT)	n/a	-	n/a 999
BCLL 0.0 *	Rep Stress Incr	YES	WB 0.08	Horz(CT)	0.00	7	n/a n/a
BCDL 10.0	Code IRC2015/TPI2014		Matrix-S				
							<b>PLATES</b> MT20
							<b>GRIP</b> 244/190
							Weight: 107 lb FT = 20%

**LUMBER-**  
 TOP CHORD 2x4 SP No.2  
 BOT CHORD 2x4 SP No.2  
 OTHERS 2x4 SP No.3

**BRACING-**  
 TOP CHORD Structural wood sheathing directly applied or 6-0-0 oc purlins.  
 BOT CHORD Rigid ceiling directly applied or 10-0-0 oc bracing.

**REACTIONS.** All bearings 30-3-14.  
 (lb) - Max Horz 1=-45(LC 6)  
 Max Uplift All uplift 100 lb or less at joint(s) 1, 7, 11, 12, 9, 8  
 Max Grav All reactions 250 lb or less at joint(s) 1, 7 except 10=323(LC 1), 11=270(LC 17), 12=504(LC 1),  
 9=270(LC 18), 8=504(LC 1)

**FORCES.** (lb) - Max. Comp./Max. Ten. - All forces 250 (lb) or less except when shown.  
 WEBS 2-12=-364/121, 6-8=-364/121

- NOTES-**
- 1) Unbalanced roof live loads have been considered for this design.
  - 2) Wind: ASCE 7-10; Vult=140mph Vasd=111mph; TC DL=6.0psf; BC DL=6.0psf; h=20ft; B=45ft; L=30ft; eave=4ft; Cat. II; Exp B; Enclosed; MWFRS (directional); cantilever left and right exposed; end vertical left and right exposed; Lumber DOL=1.60 plate grip DOL=1.60
  - 3) All plates are 1.5x4 MT20 unless otherwise indicated.
  - 4) Gable requires continuous bottom chord bearing.
  - 5) This truss has been designed for a 10.0 psf bottom chord live load nonconcurrent with any other live loads.
  - 6) \* This truss has been designed for a live load of 20.0psf on the bottom chord in all areas with a clearance greater than 6-0-0 between the bottom chord and any other members.
  - 7) Provide mechanical connection (by others) of truss to bearing plate capable of withstanding 100 lb uplift at joint(s) 1, 7, 11, 12, 9, 8.



October 30, 2021



12-11-6 25-10-11  
 12-11-6 12-11-6

Scale = 1.41.3

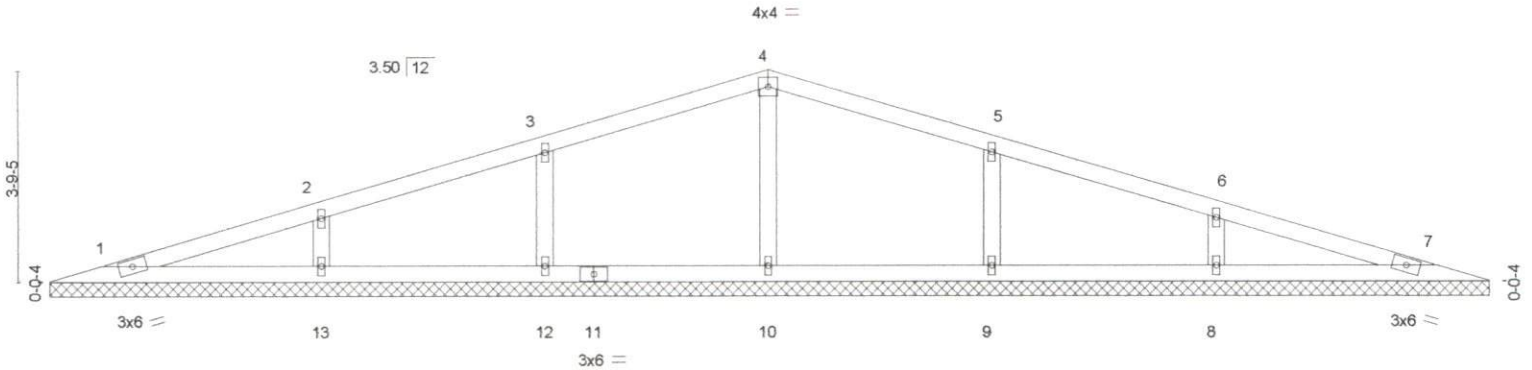

0-0.14 25-10-11  
 0-0.14 25-9-14

LOADING (psf)	SPACING-	2-0-0	CSI.	DEFL.	in (loc)	l/defl	L/d	PLATES	GRIP
TCLL 20.0	Plate Grip DOL	1.15	TC 0.19	Vert(LL)	n/a	-	n/a	MT20	244/190
TCDL 10.0	Lumber DOL	1.15	BC 0.13	Vert(CT)	n/a	-	n/a		
BCLL 0.0 *	Rep Stress Incr	YES	WB 0.06	Horz(CT)	0.00	7	n/a		
BCDL 10.0	Code IRC2015/TPI2014		Matrix-S					Weight: 89 lb	FT = 20%

**LUMBER-**  
 TOP CHORD 2x4 SP No.2  
 BOT CHORD 2x4 SP No.2  
 OTHERS 2x4 SP No.3

**BRACING-**  
 TOP CHORD Structural wood sheathing directly applied or 6-0-0 oc purlins.  
 BOT CHORD Rigid ceiling directly applied or 10-0-0 oc bracing.

**REACTIONS.** All bearings 25-9-0.  
 (lb) - Max Horz 1=-38(LC 6)  
 Max Uplift All uplift 100 lb or less at joint(s) 1, 7, 12, 13, 9, 8  
 Max Grav All reactions 250 lb or less at joint(s) 1, 7 except 10=295(LC 1), 12=331(LC 17), 13=352(LC 1),  
 9=331(LC 18), 8=352(LC 1)

**FORCES.** (lb) - Max. Comp./Max. Ten. - All forces 250 (lb) or less except when shown.  
 WEBS 3-12=-255/87, 2-13=-257/87, 5-9=-255/87, 6-8=-257/87

- NOTES-**
- Unbalanced roof live loads have been considered for this design.
  - Wind: ASCE 7-10; Vult=140mph Vasd=111mph; TC DL=6.0psf; BCDL=6.0psf; h=20ft; B=45ft; L=26ft; eave=4ft; Cat. II; Exp B; Enclosed; MWFRS (directional); cantilever left and right exposed; end vertical left and right exposed; Lumber DOL=1.60 plate grip DOL=1.60
  - All plates are 1.5x4 MT20 unless otherwise indicated.
  - Gable requires continuous bottom chord bearing.
  - This truss has been designed for a 10.0 psf bottom chord live load nonconcurrent with any other live loads.
  - \* This truss has been designed for a live load of 20.0psf on the bottom chord in all areas with a clearance greater than 6-0-0 between the bottom chord and any other members.
  - Provide mechanical connection (by others) of truss to bearing plate capable of withstanding 100 lb uplift at joint(s) 1, 7, 12, 13, 9, 8.



October 30, 2021



10-7-15 21-3-14  
 10-7-15 10-7-15

Scale = 1:34.0

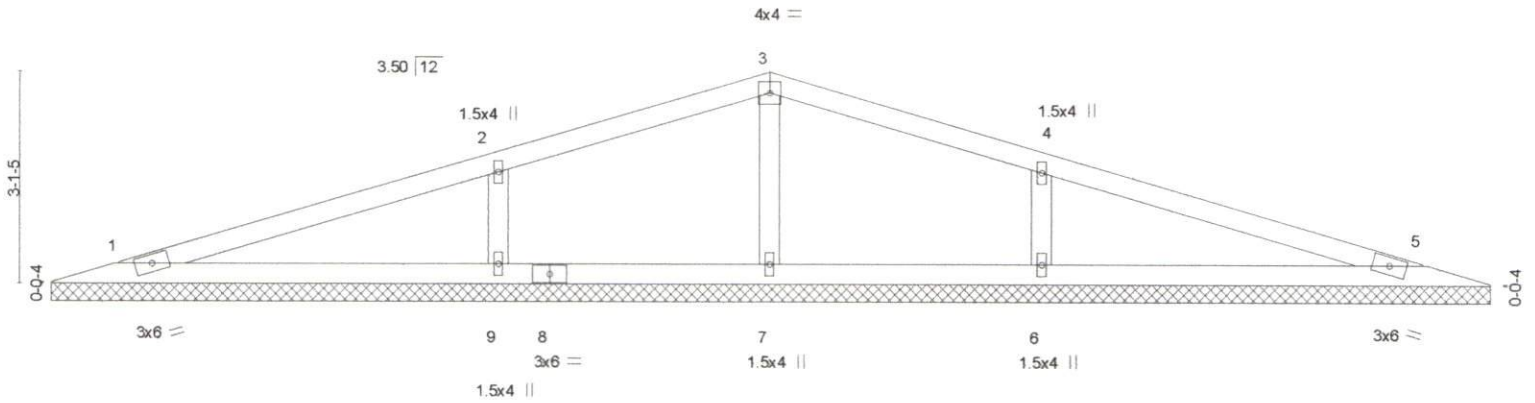

21-3-0 21-3-14  
 21-3-0 0-0:14

LOADING (psf)	SPACING-	2-0-0	CSI.	DEFL.	in (loc)	l/defl	L/d	PLATES	GRIP
TCLL 20.0	Plate Grip DOL	1.15	TC 0.39	Vert(LL)	n/a	-	n/a	MT20	244/190
TCDL 10.0	Lumber DOL	1.15	BC 0.25	Vert(CT)	n/a	-	n/a		
BCLL 0.0 *	Rep Stress Incr	YES	WB 0.07	Horz(CT)	0.00	5	n/a		
BCDL 10.0	Code IRC2015/TPI2014		Matrix-S					Weight: 69 lb	FT = 20%

**LUMBER-**  
 TOP CHORD 2x4 SP No.2  
 BOT CHORD 2x4 SP No.2  
 OTHERS 2x4 SP No.3

**BRACING-**  
 TOP CHORD Structural wood sheathing directly applied or 6-0-0 oc purlins.  
 BOT CHORD Rigid ceiling directly applied or 10-0-0 oc bracing.

**REACTIONS.** All bearings 21-2-2.  
 (lb) - Max Horz 1=-31(LC 6)  
 Max Uplift All uplift 100 lb or less at joint(s) 1, 5, 9, 6  
 Max Grav All reactions 250 lb or less at joint(s) 1, 5, 7 except 9=483(LC 17), 6=483(LC 18)

**FORCES.** (lb) - Max. Comp./Max. Ten. - All forces 250 (lb) or less except when shown.  
 WEBS 2-9=-354/117, 4-6=-354/117

- NOTES-**
- Unbalanced roof live loads have been considered for this design.
  - Wind: ASCE 7-10; Vult=140mph Vasd=111mph; TCDL=6.0psf; BCDL=6.0psf; h=20ft; B=45ft; L=24ft; eave=4ft; Cat. II; Exp B; Enclosed; MWFRS (directional); cantilever left and right exposed; end vertical left and right exposed; Lumber DOL=1.60 plate grip DOL=1.60
  - Gable requires continuous bottom chord bearing.
  - This truss has been designed for a 10.0 psf bottom chord live load nonconcurrent with any other live loads.
  - \* This truss has been designed for a live load of 20.0psf on the bottom chord in all areas with a clearance greater than 6-0-0 between the bottom chord and any other members.
  - Provide mechanical connection (by others) of truss to bearing plate capable of withstanding 100 lb uplift at joint(s) 1, 5, 9, 6.



October 30, 2021

**WARNING - Verify design parameters and READ NOTES ON THIS AND INCLUDED MITEK REFERENCE PAGE MII-7473 rev. 5/19/2020 BEFORE USE.**  
 Design valid for use only with MiTek® connectors. This design is based only upon parameters shown, and is for an individual building component, not a truss system. Before use, the building designer must verify the applicability of design parameters and properly incorporate this design into the overall building design. Bracing indicated is to prevent buckling of individual truss web and/or chord members only. Additional temporary and permanent bracing is always required for stability and to prevent collapse with possible personal injury and property damage. For general guidance regarding the





6-1-1 6-1-1 12-2-2 6-1-1

Scale = 1:19.3

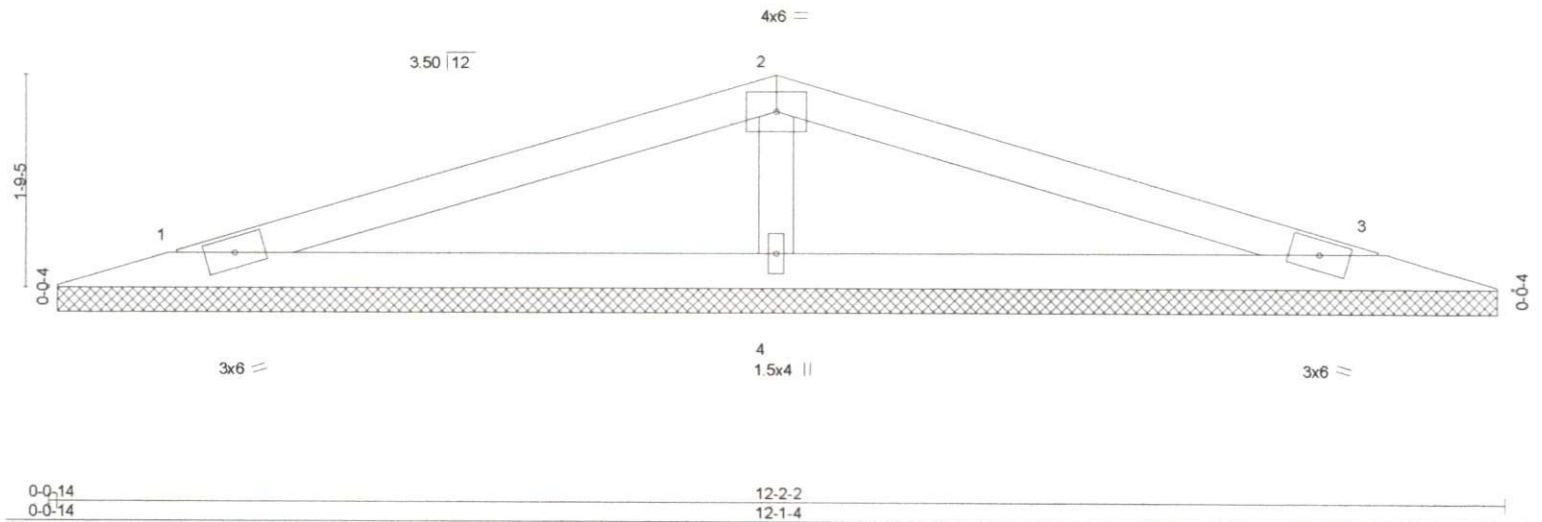

LOADING (psf)	SPACING-	CSI.	DEFL.	PLATES	GRIP
TCLL 20.0	2-0-0	TC 0.36	in (loc) l/defl L/d	MT20	244/190
TCDL 10.0	Plate Grip DOL 1.15	BC 0.25	Vert(LL) n/a - n/a 999		
BCLL 0.0 *	Lumber DOL 1.15	WB 0.06	Vert(CT) n/a - n/a 999		
BCDL 10.0	Rep Stress Incr YES	Matrix-S	Horz(CT) 0.00 3 n/a n/a		
	Code IRC2015/TPI2014			Weight: 35 lb	FT = 20%

**LUMBER-**  
 TOP CHORD 2x4 SP No.2  
 BOT CHORD 2x4 SP No.2  
 OTHERS 2x4 SP No.3

**BRACING-**  
 TOP CHORD Structural wood sheathing directly applied or 6-0-0 oc purlins.  
 BOT CHORD Rigid ceiling directly applied or 10-0-0 oc bracing.

**REACTIONS.** (size) 1=12-0-7, 3=12-0-7, 4=12-0-7  
 Max Horz 1=-16(LC 6)  
 Max Uplift 1=-19(LC 8), 3=-19(LC 8), 4=-24(LC 8)  
 Max Grav 1=176(LC 17), 3=176(LC 18), 4=463(LC 1)

**FORCES.** (lb) - Max. Comp./Max. Ten. - All forces 250 (lb) or less except when shown.  
 WEBS 2-4=-317/87

- NOTES-**
- Unbalanced roof live loads have been considered for this design.
  - Wind: ASCE 7-10; Vult=140mph Vasd=111mph; TC DL=6.0psf; BCDL=6.0psf; h=20ft; B=45ft; L=24ft; eave=4ft; Cat. II; Exp B; Enclosed; MWFRS (directional); cantilever left and right exposed; end vertical left and right exposed; Lumber DOL=1.60 plate grip DOL=1.60
  - Gable requires continuous bottom chord bearing.
  - This truss has been designed for a 10.0 psf bottom chord live load nonconcurrent with any other live loads.
  - \* This truss has been designed for a live load of 20.0psf on the bottom chord in all areas with a clearance greater than 6-0-0 between the bottom chord and any other members.
  - Provide mechanical connection (by others) of truss to bearing plate capable of withstanding 100 lb uplift at joint(s) 1, 3, 4.



October 30, 2021

**WARNING - Verify design parameters and READ NOTES ON THIS AND INCLUDED MITEK REFERENCE PAGE MII-7473 rev. 5/19/2020 BEFORE USE.**  
 Design valid for use only with MiTek® connectors. This design is based only upon parameters shown, and is for an individual building component, not a truss system. Before use, the building designer must verify the applicability of design parameters and properly incorporate this design into the overall building design. Bracing indicated is to prevent buckling of individual truss web and/or chord members only. Additional temporary and permanent bracing is always required for stability and to prevent collapse with possible personal injury and property damage. For general guidance regarding the



# Symbols

## PLATE LOCATION AND ORIENTATION

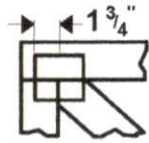

Center plate on joint unless x, y offsets are indicated. Dimensions are in ft-in-sixteenths. Apply plates to both sides of truss and fully embed teeth.

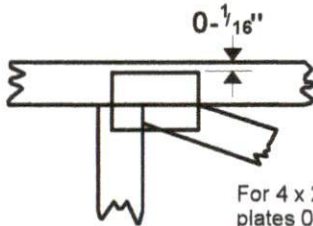

For 4 x 2 orientation, locate plates 0- $\frac{1}{16}$ " from outside edge of truss.



This symbol indicates the required direction of slots in connector plates.

\* Plate location details available in MiTek 20/20 software or upon request.

## PLATE SIZE

4 x 4

The first dimension is the plate width measured perpendicular to slots. Second dimension is the length parallel to slots.

## LATERAL BRACING LOCATION



Indicated by symbol shown and/or by text in the bracing section of the output. Use T or I bracing if indicated.

## BEARING



Indicates location where bearings (supports) occur. Icons vary but reaction section indicates joint number where bearings occur. Min size shown is for crushing only.

## Industry Standards:

- ANSI/TPI1: National Design Specification for Metal Plate Connected Wood Truss Construction.
- DSB-89: Design Standard for Bracing.
- BCSI: Building Component Safety Information, Guide to Good Practice for Handling, Installing & Bracing of Metal Plate Connected Wood Trusses.

# Numbering System

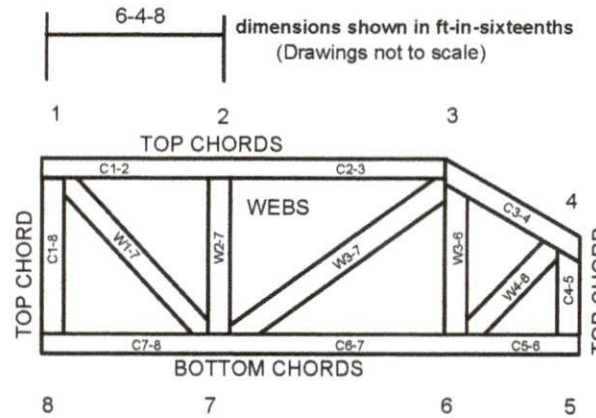

JOINTS ARE GENERALLY NUMBERED/LETTERED CLOCKWISE AROUND THE TRUSS STARTING AT THE JOINT FARTHEST TO THE LEFT.

CHORDS AND WEBS ARE IDENTIFIED BY END JOINT NUMBERS/LETTERS.

## PRODUCT CODE APPROVALS

ICC-ES Reports:

ESR-1311, ESR-1352, ESR1988  
ER-3907, ESR-2362, ESR-1397, ESR-3282

Trusses are designed for wind loads in the plane of the truss unless otherwise shown.

Lumber design values are in accordance with ANSI/TPI 1 section 6.3 These truss designs rely on lumber values established by others.

© 2012 MiTek® All Rights Reserved



MiTek Engineering Reference Sheet: MII-7473 rev. 5/19/2020



# General Safety Notes

## Failure to Follow Could Cause Property Damage or Personal Injury

1. Additional stability bracing for truss system, e.g. diagonal or X-bracing, is always required. See BCSI.
2. Truss bracing must be designed by an engineer. For wide truss spacing, individual lateral braces themselves may require bracing, or alternative Tor 1 bracing should be considered.
3. Never exceed the design loading shown and never stack materials on inadequately braced trusses.
4. Provide copies of this truss design to the building designer, erection supervisor, property owner and all other interested parties.
5. Cut members to bear tightly against each other.
6. Place plates on each face of truss at each joint and embed fully. Knots and wane at joint locations are regulated by ANSI/TPI 1.
7. Design assumes trusses will be suitably protected from the environment in accord with ANSI/TPI 1.
8. Unless otherwise noted, moisture content of lumber shall not exceed 19% at time of fabrication.
9. Unless expressly noted, this design is not applicable for use with fire retardant, preservative treated, or green lumber.
10. Camber is a non-structural consideration and is the responsibility of truss fabricator. General practice is to camber for dead load deflection.
11. Plate type, size, orientation and location dimensions indicated are minimum plating requirements.
12. Lumber used shall be of the species and size, and in all respects, equal to or better than that specified.
13. Top chords must be sheathed or purlins provided at spacing indicated on design.
14. Bottom chords require lateral bracing at 10 ft. spacing, or less, if no ceiling is installed, unless otherwise noted.
15. Connections not shown are the responsibility of others.
16. Do not cut or alter truss member or plate without prior approval of an engineer.
17. Install and load vertically unless indicated otherwise.
18. Use of green or treated lumber may pose unacceptable environmental, health or performance risks. Consult with project engineer before use.
19. Review all portions of this design (front, back, words and pictures) before use. Reviewing pictures alone is not sufficient.
20. Design assumes manufacture in accordance with ANSI/TPI 1 Quality Criteria.
21. The design does not take into account any dynamic or other loads other than those expressly stated.