

3.5" Concrete slab

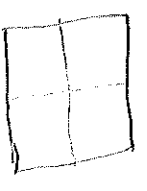
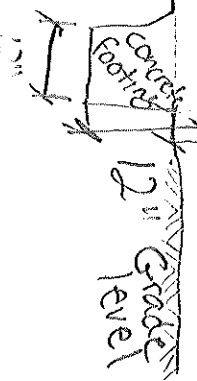

8' Tall

31 Park Ln Coats NC 27521

12X16 storage building on 4" concrete slab wood studs & trusses every 16" OC, shingles roofing & vinyl siding (sand color)

wood studs 16" OC

Vinyl siding (All around)

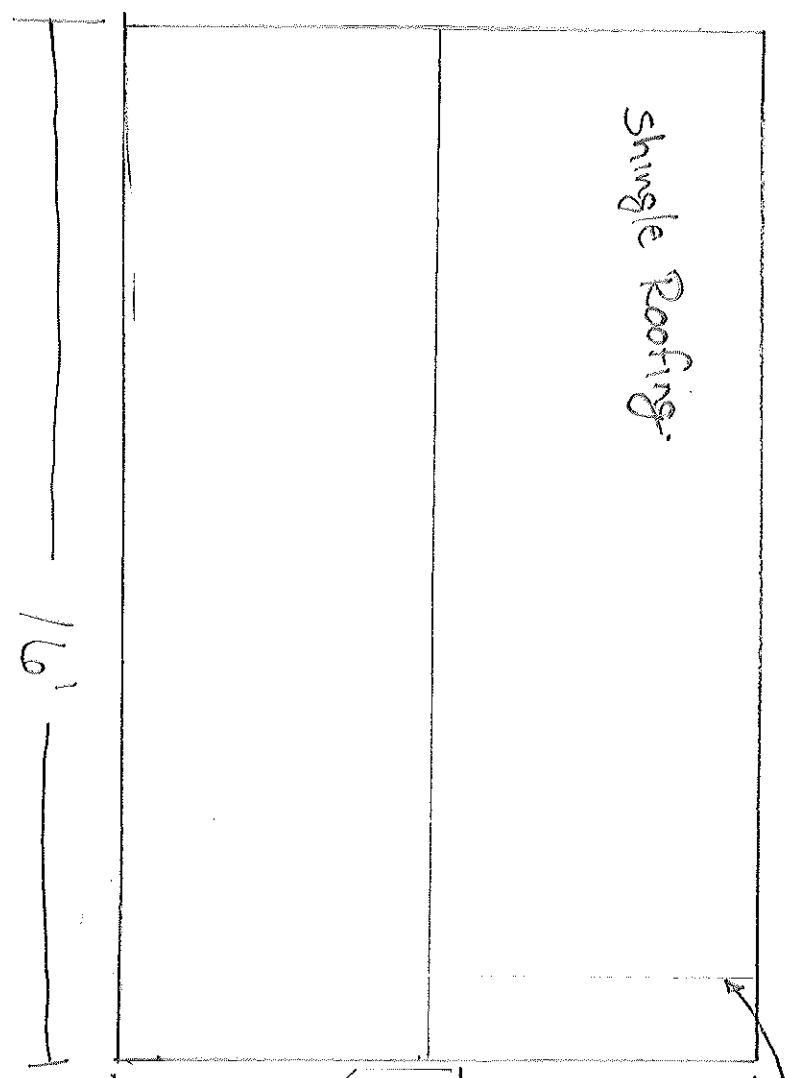

Wood trusses 16" OC

10' Tall To the Peak

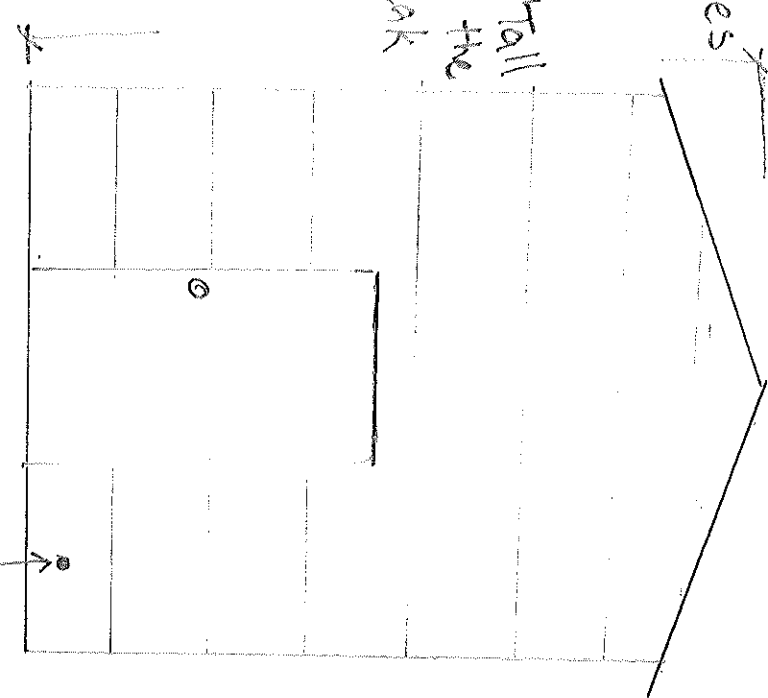

Vinyl siding

FOUNDATIONS

This is for Frost Protection... bottom of footing must be at least 12" below grade

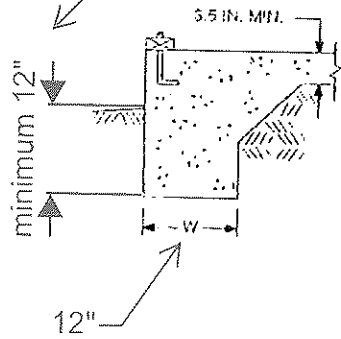

**TABLE R403.1
MINIMUM WIDTH OF CONCRETE,
PRECAST OR MASONRY FOOTINGS (Inches)^a**

	LOAD-BEARING VALUE OF SOIL (psf)			
	1,500	2,000	3,000	≥ 4,000
Conventional light-frame construction				
1-story	12 ^b	12 ^b	12	12
2-story	15 ^b	12 ^b	12	12
3-story	23	17	12	12
4-inch brick veneer over light frame or 8-inch hollow concrete masonry				
1-story	12 ^b	12 ^b	12	12
2-story	15 ^b	15 ^b	12	12
3-story	32	24	16	12
8-inch solid or fully grouted masonry				
1-story	16	12	12	12
2-story	29	21	14	12
3-story	42	32	21	16

For SI: 1 inch = 25.4 mm, 1 pound per square foot = 0.0479 kPa.
 a. Where minimum footing width is 12 inches, use of a single wythe of solid or fully grouted 12-inch nominal concrete masonry units is permitted.
 b. A minimum footing width of 12 inches is acceptable for monolithic slab foundations.

R403.1.2 Continuous footing in Seismic Design Categories D₀, D₁ and D₂. Deleted.

R403.1.3 Seismic reinforcing. Deleted.

R403.1.3.1 Foundations with stemwalls. Deleted.

R403.1.3.2 Slabs-on-ground with turned-down footings. Deleted.

R403.1.4 Minimum depth. All exterior footings and foundation systems shall extend below the frost line specified in Table R301.2(1). In no case shall the bottom of the exterior footings be less than 12 inches below the finished grade.

Exception: Frost protected footings constructed in accordance with Section R403.3 and footings and foundations erected on solid rock shall not be required to extend below the frost line.

R403.1.4.1 Frost protection. Deleted.

R403.1.4.2 Seismic conditions. Deleted.

R403.1.5 Slope. The top surface of footings shall be level ($\frac{1}{2}$ inch in 10 feet) or shall be brought level, under the width of the wall, with masonry units with full mortar joints. The bottom surface of footings may have a slope not exceeding one unit vertical in 10 units horizontal (10-percent slope). Footings shall be stepped where it is necessary to change the elevation of the top surface of the footings or where the slope of the bottom surface of the footings will exceed one unit vertical in ten units horizontal (10-percent slope).

**TABLE R403.1a
PIER¹ AND FOOTING² SIZES FOR SUPPORT OF GIRDERS**

Area ⁵	1 (One) STORY		2 (Two) STORY		2-1/2 (Two & One Half) STORY	
	Pier ^{3,4}	Footing	Pier ^{3,4}	Footing	Pier ^{3,4}	Footing
50	8" x 16"	1'-4" x 2'-0" x 8"	8" x 16"	1'-4" x 2'-6" x 8"	8" x 16"	1'-4" x 2'-6" x 8"
100	8" x 16"	1'-4" x 2'-0" x 8"	8" x 16"	2'-0" x 2'-0" x 10"	16" x 16"	2'-6" x 2'-6" x 10"
150	8" x 16"	2'-0" x 2'-0" x 8"	16" x 16"	2'-8" x 2'-8" x 10"	16" x 16"	3'-0" x 3'-0" x 10"
200	8" x 16"	2'-4" x 2'-4" x 10"	16" x 16"	3'-0" x 3'-0" x 10"	16" x 16"	3'-11" x 3'-8" x 1'-0"
250	—	—	16" x 16"	3'-4" x 3'-4" x 1'-0"	16" x 24"	4'-0" x 4'-0" x 1'-0"
300	—	—	16" x 16"	3'-8" x 3'-8" x 1'-0"	16" x 24"	4'-6" x 4'-6" x 1'-0"

For SI: 1 inch = 25.4 mm, 1 foot = 304.8 mm, 1 pound per square inch = 6.895 kPa, 1 pound per square foot = 0.0479 kPa.
 1. Pier sizes are based on hollow CMU capped with 4 inches of solid masonry or concrete for 1 (one) story and 8 inches of solid masonry or concrete for 2 (two) and 2-1/2 (two and one half) story houses or shall have cavities of the top course filled with concrete or grout or other approved methods. Mortar shall be Type S.
 2. Footing sizes are based on 2000 psf allowable soil bearing and 2500 psi concrete. This table is based upon the limitations of a tributary area using dimensional framing lumber only.
 3. Centers of piers shall bear in the middle one-third of the footings. Girders must have full bearing on piers. Footings shall be full thickness over the entire area of the footing.
 4. Pier sizes given are minimum. For height/thickness limitations see Section R606.6.
 5. Area at first level supported by pier and footing (square foot).