

ROOF VENTILATING REQUIREMENTS
 $\frac{480}{150} = 3.2 \text{ SQ. FT. REQ'D}$

ROOF VENTILATING REQUIREMENTS
 (POWER ROOF VENTILATOR REQUIRED)
 $\frac{480}{300} = 1.6 \text{ SQ. FT. REQ'D}$

BUILDER TO PROVIDE APPROPRIATE VENTILATING AS REQUIRED.

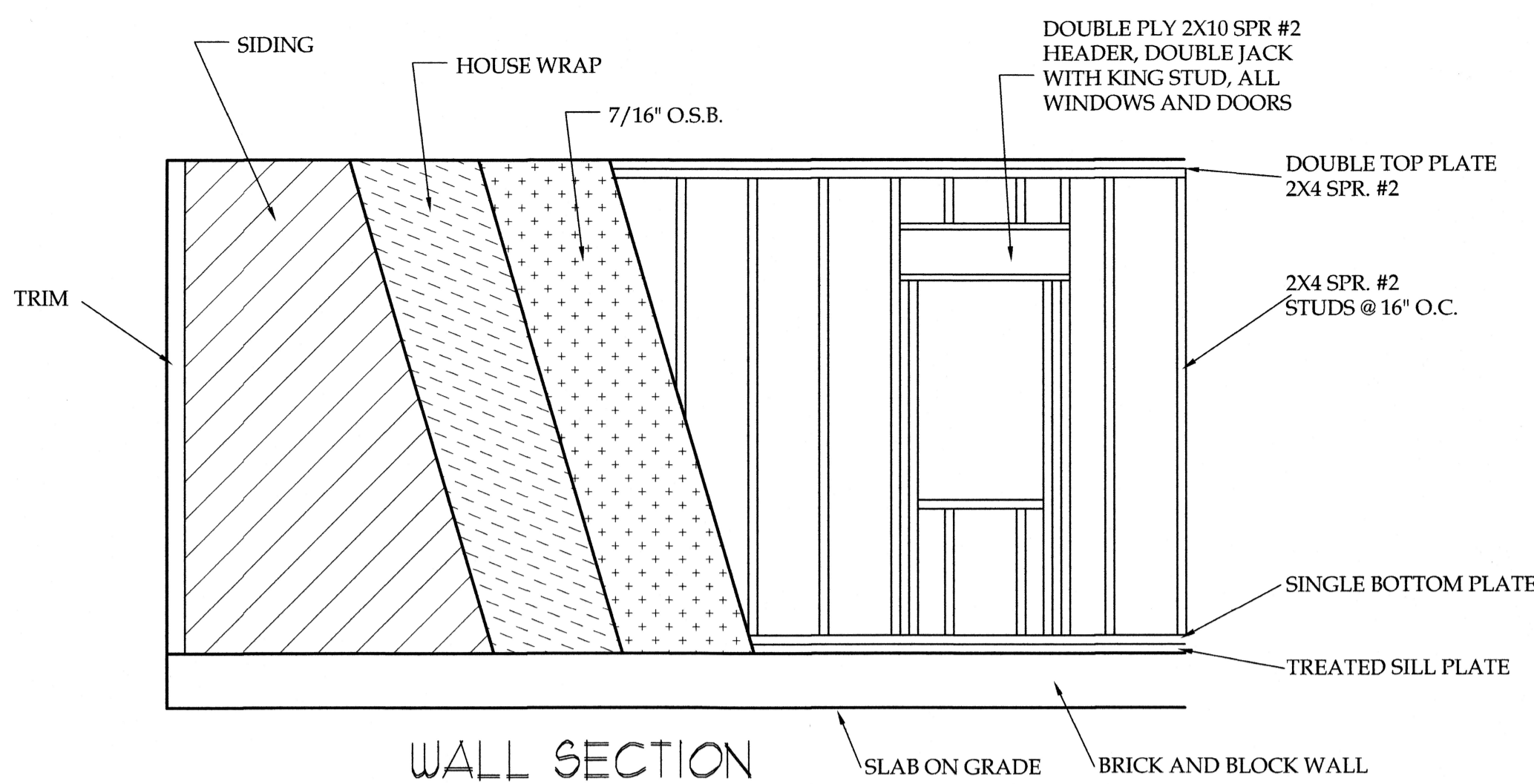

WALL SECTION

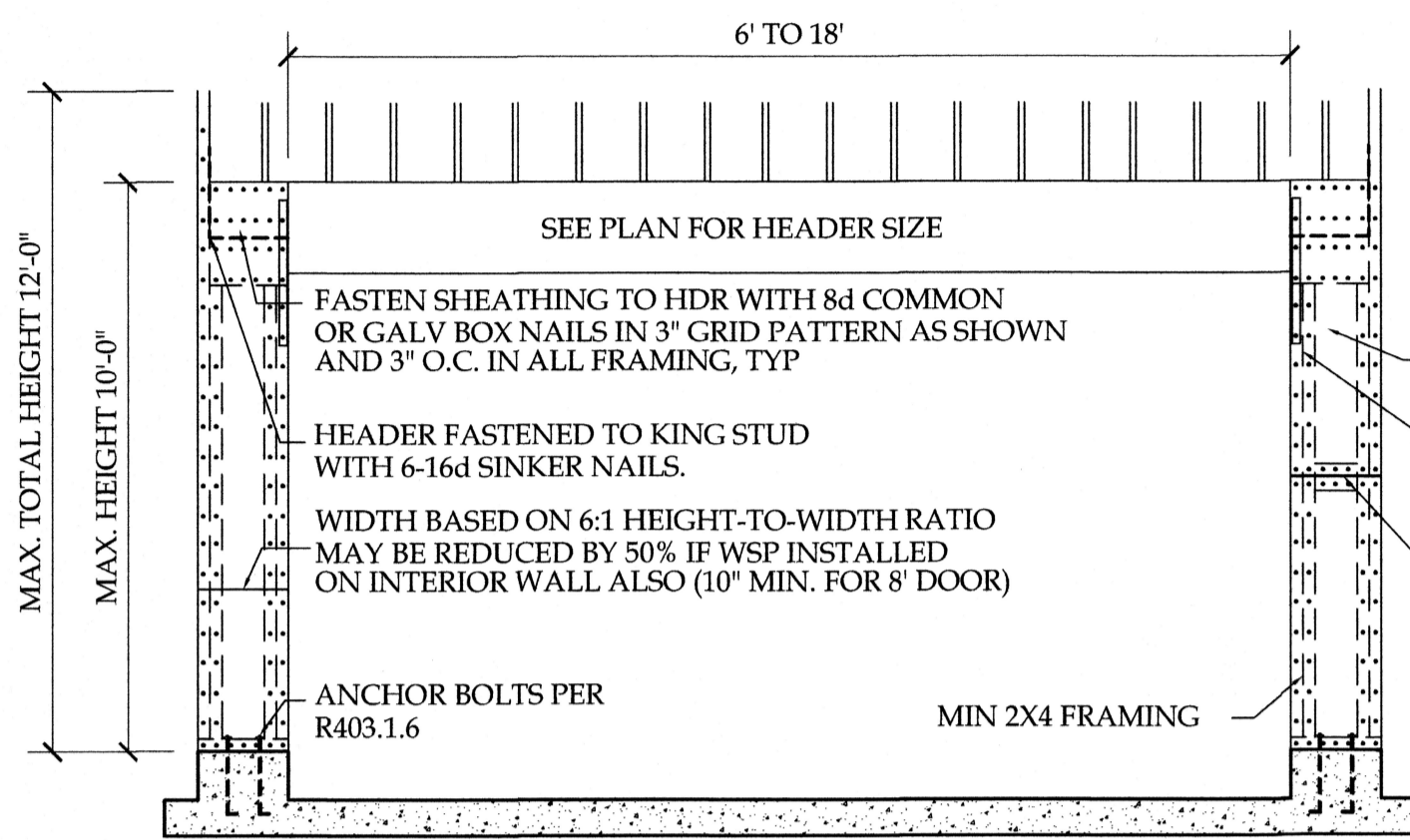

PORTAL FRAME DETAIL

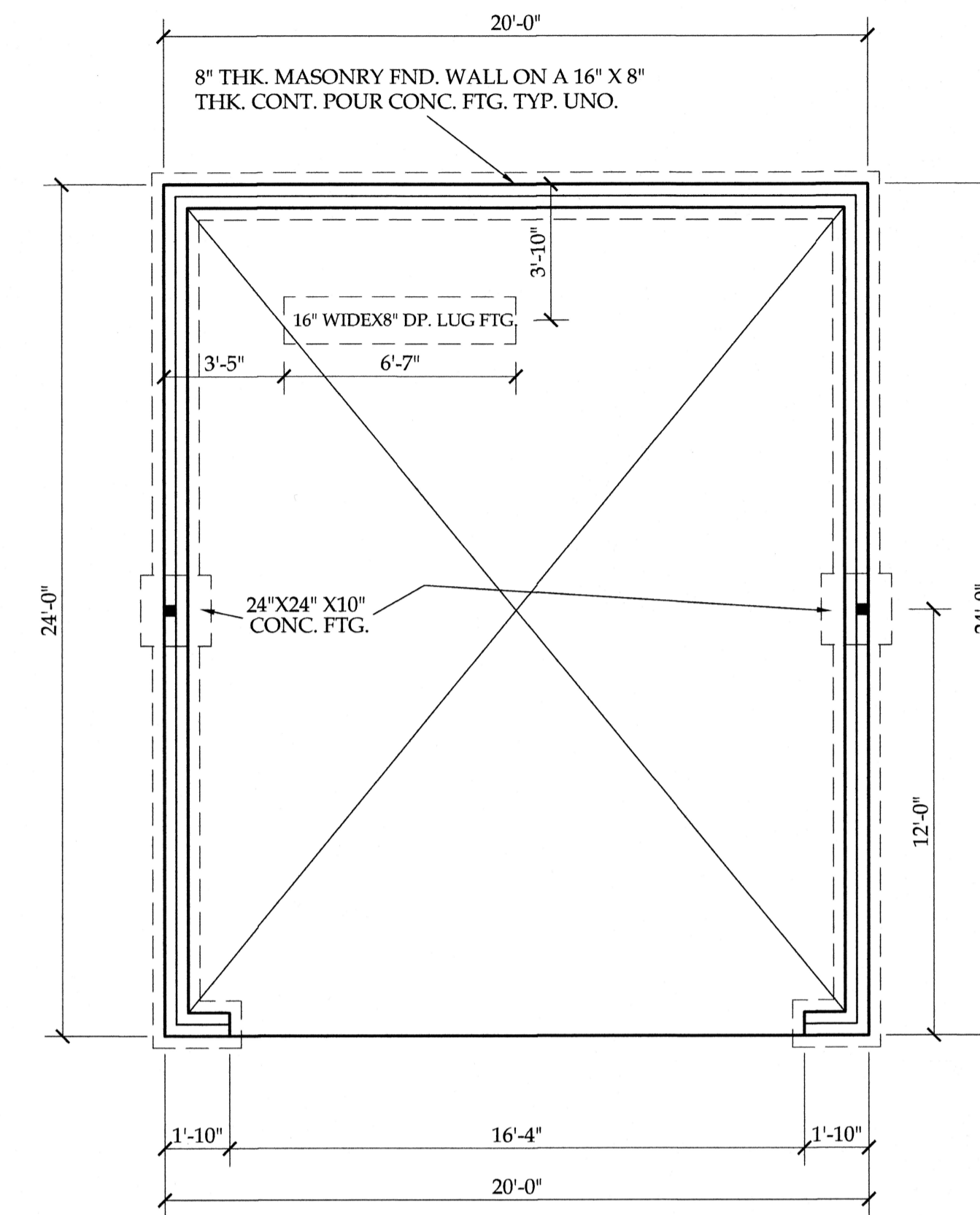

FOUNDATION PLAN

SCALE: 1/8"=1'-0"

STRUCTURAL NOTES

- ALL CONSTRUCTION SHALL CONFORM TO THE LATEST REQUIREMENTS OF NORTH CAROLINA STATE RESIDENTIAL BUILDING CODE, IN ADDITION TO ALL LOCAL CODES AND REGULATIONS.
- DESIGN LOADS:

	LIVE LOAD (PSF)	DEAD LOAD (PSF)	DEFLECTION (DL & LL)
ALL FLOORS	40	10	L/240
ATTIC (no snow)	20	10	L/240
ATTIC (no snow)	30	5	L/240
EXTERNAL BALCONY	60	10	L/240
ROOF	20	10	L/240
ROOF TRUSS	20	10	L/240
WIND LOAD	(BASED ON 120 MPH (3-second gust))		
- MINIMUM ALLOWABLE SOIL BEARING PRESSURE = 2000 PSF
- CONCRETE SHALL HAVE A MINIMUM 28 DAY STRENGTH OF 3000 PSI AND A MAXIMUM SLOPE OF FIVE INCHES UNLESS NOTED OTHERWISE (L.S.).
- MAXIMUM DEPTH OF UNBALANCED FILL AGAINST FOUNDATION WALLS TO BE LESS THAN 4" WITHOUT USING SUFFICIENT BRACING. REFER TO SECTION 804 OF 2012 IBC BUILDING CODE FOR BACKFILL LIMITATIONS BASED ON WALL HEIGHT, WALL THICKNESS, SOIL TYPE, AND UNBALANCED BACKFILL HEIGHT.
- ALL FRAMING LUMBER SHALL BE SPF #2 (S-P-F) OR #1 (S-P-F) LUMBER.
- ALL FRAMING LUMBER EXPOSED TO THE ELEMENTS SHALL BE TREATED MATERIAL.
- ALL LOAD BEARING HEADERS SHALL BE GRAP (LUM). ALL WINDOW AND DOOR HEADERS SHALL BE SUPPORTED BY (1) JACK STUD AND (2) KING STUD AT EACH END UNLESS NOTED. ALL OTHER BEAMS SHALL BE SUPPORTED BY STUDS OR THE SKEWETS OF STUDS REQUIRED FOR FULL BEARING AT EACH END UNLESS NOTED. POINT LOADS (STBY KNEE, ETC.) SHALL CONSIST OF 2 STUDS UNLESS NOTED. ALL SUPPORTS OF 2 STUDS OR MORE SHALL BE TRANSFERRED THROUGH EACH FLOOR TO THE FOUNDATION.
- ALL EXTERIOR WALLS TO BE SHEATHED WITH MIN. 7/16" WOOD STRUCTURAL PANELS FASTENED WITH 8d NAILS @ 6" O.C. AT EDGES AND 12" O.C. AT INT. SUPPORTS. BLOCKING SHALL BE INSTALLED FLUSH WITH 5/8" OF THE WALL LENGTH IS SHEATHED WHERE BLOCKING IS REQ'D. ALL PANELS SHALL BE FASTENED AT 7" O.C. AT EDGES AND 12" O.C. AT INT. SUPPORTS.
- ALL STRUCTURAL STEEL SHALL HAVE A MIN. STEEL BEARING SHALL BE SUPPORTED AT EACH END WITH A MINIMUM BEARING LENGTH OF 3 1/2" INCHES AND FULL FLANGE WIDTH. PROVIDE SOLID BEARING FROM BEAM SUPPORT TO FOUNDATION. BEAMS SHALL BE ATTACHED TO EACH SUPPORT WITH TWO LAG SCREWS (1/2" DIAMETER AND 4" LONG). LATERAL SUPPORT IS CONSIDERED ADEQUATE PROVIDED THE JOISTS ARE SEALED TO THE SLAB PLATES, AND THE SLAB PLATES ARE NAILED OR BOLTED TO THE BEAM FLANGES @ 4" O.C.
- ANCHOR BOLT PLACEMENT PER SECTION 803.1.6. 1/2" DIAMETER ANCHOR BOLTS SPACED AT 4" O.C. AND PLACED 12" FROM THE END OF EACH SECTION.
- FOUNDATION DRAINAGE DAMP PROOFING OR WATERPROOFING PER SECTION 405 AND 406 OF 2012 IBC BUILDING CODE.
- WALL AND ROOF CLADDING VALLES.
- WALL CLADDING SHALL BE THICKENED FOR A 2x1 SQFT. OR GREATER POSITIVE AND NEGATIVE PRESSURE. ROOF VALLES BOTH POSITIVE AND NEGATIVE SHALL BE AS FOLLOWS:
 - 65 LB/SQFT FOR ROOF PITCHES OF 0/12 TO 2/12
 - 54 LB/SQFT FOR ROOF PITCHES OF 2 1/2 TO 12/12
 - 21 LB/SQFT FOR ROOF PITCHES OF 1/12 TO 1/12
- MEAN ROOF HEIGHT TO OR LESS.
- FOR ROOF SLOPES FROM 1/12 TO 1/12 HIGH 1/2" BUILDER TO INSTALL 11 LAYERS OF 5/8 PLY PAPER.
- IT IS THE CONTRACTOR'S RESPONSIBILITY TO VERIFY ALL DIMENSIONS AND SQ. FTG. ARE CORRECT PRIOR TO CONSTRUCTION. DESIGNER IS NOT RESPONSIBLE FOR DIMENSIONING OR SQ. FTG. ERRORS ONCE CONSTRUCTION BEGINS.

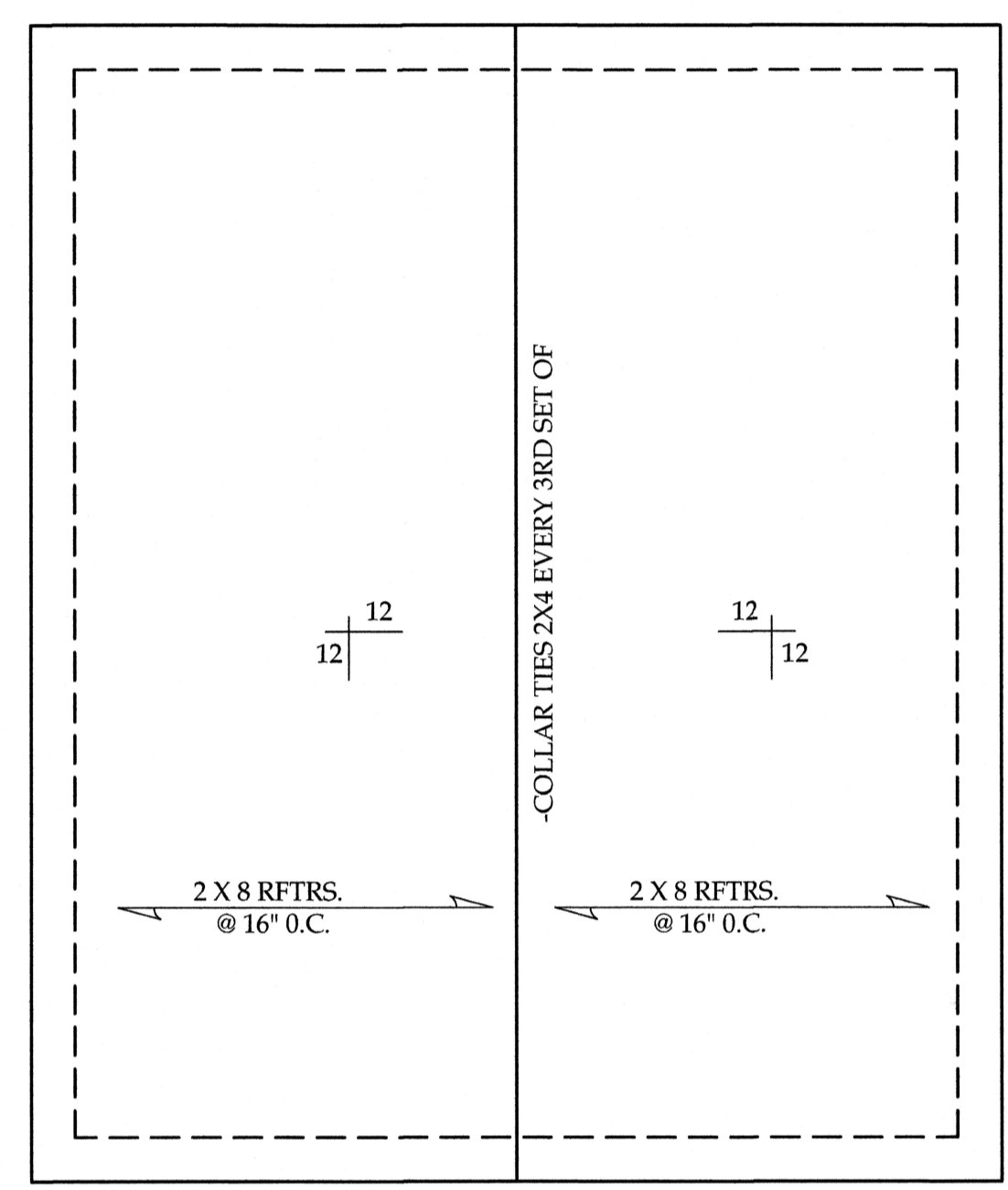

ROOF ELEVATION

SCALE: 1/8"=1'-0"

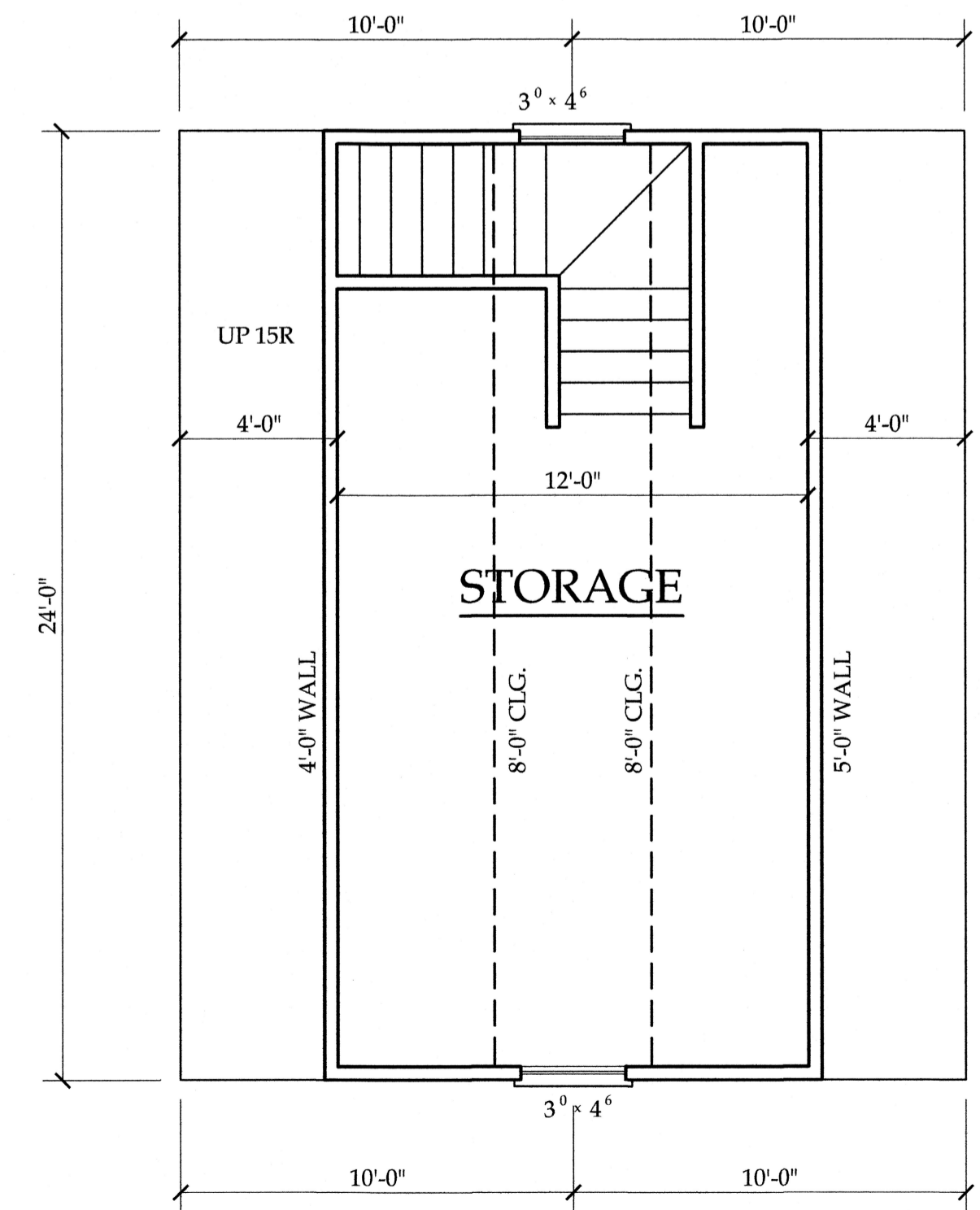

SECOND FLOOR

SCALE: 1/4"=1'-0"

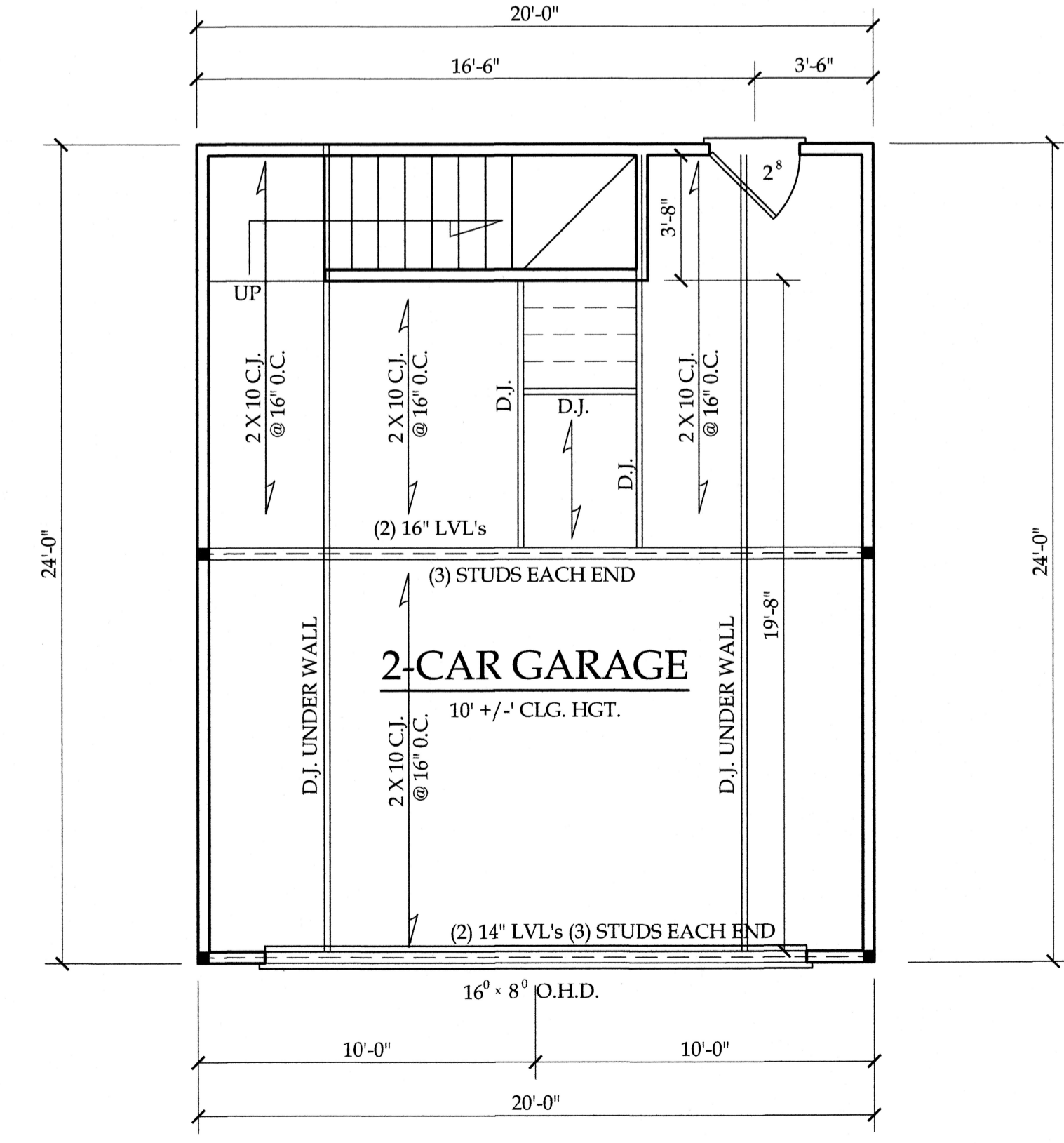

FIRST FLOOR

SCALE: 1/4"=1'-0"

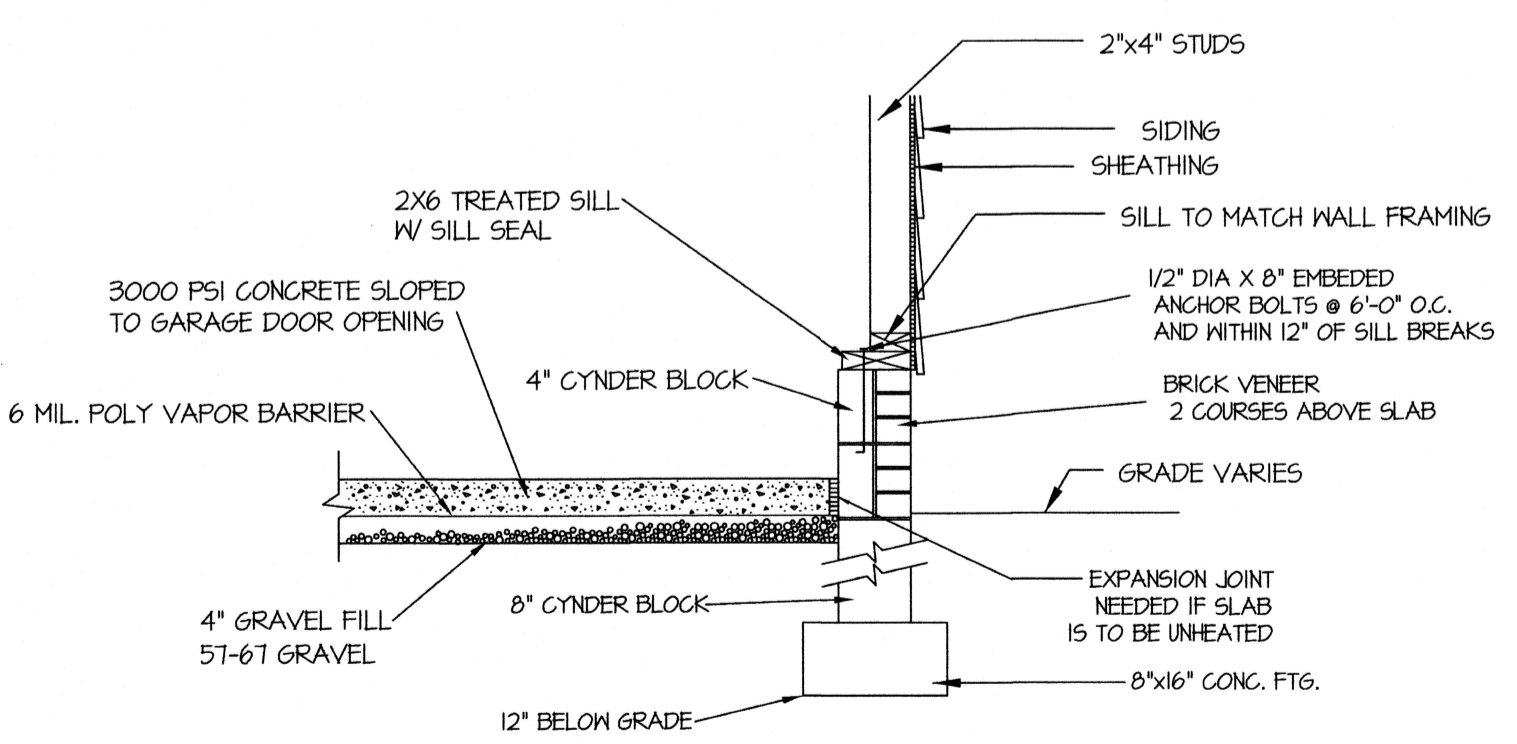

SLAB FDN. DETAIL

AS MIGUEL SURNAME
 MIGUEL SURNAME
 BUS 110.0005
 12-2-21
 17-2-21

MIGUEL FLORES RESIDENCE

1584 Wire Rd Bumblelevel 28323

DRAWN BY:
 D.V.O.

DATE:
 12/2/21

PAGE NO

1
 OF
 1

24X20
 GARAGE