



STRUCTURAL DESIGN

ENCLOSED BUILDING

**MAXIMUM 30'- 0" WIDE X 16'- 0" EAVE HEIGHT-
BOX EAVE FRAME AND BOW FRAME**

17 June 2021

Revision 3

M&A Project No. 17171S/18253S/20376S/21118S

Prepared for:

**Carport Central, Inc.
137 South Main Street
Mt. Airy, NC 27030**

Prepared by:

Moore and Associates Engineering and Consulting, Inc.

**1009 East Avenue
North Augusta, SC 29841**









**401 S. Main Street, Suite 200
Mt. Airy, NC 27030**

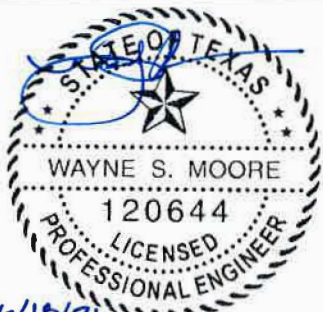

MOORE AND ASSOCIATES
ENGINEERING AND CONSULTING

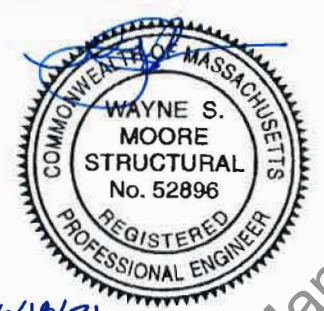
		<p>I HAVE RESEARCHED THIS CHAPTER AND THE LOUISIANA STATE UNIFORM CONSTRUCTION CODE AND TO THE BEST OF MY KNOWLEDGE AND BELIEF, THESE DRAWINGS ARE IN COMPLIANCE THEREWITH. I TAKE FULL RESPONSIBILITY FOR THE CONTENTS OF THESE PLANS.</p>	

<p>MOORE AND ASSOCIATES ENGINEERING AND CONSULTING, INC.</p>		<p>DRAWN BY: JG</p>		<p>CARPENT CENTRAL, INC. 737 SOUTH MAIN STREET MOUNT AIRY, NC 27030</p>	
		<p>CHECKED BY: PDH</p>		<p>30'-0" x 16'-0" ENCLOSED STRUCTURE</p>	
<p>PROJECT MGR: VSM</p>		<p>DATE: 6-17-21</p>		<p>SCALE: NTS</p>	
<p>CLIENT: CC</p>		<p>SHT. 1</p>		<p>DWG. NO.: SK-3</p>	
<p><small>THIS DOCUMENT IS THE PROPERTY OF MOORE AND ASSOCIATES ENGINEERING AND CONSULTING. THE UNAUTHORIZED REPRODUCTION, COPYING, OR OTHERWISE USE OF THIS DOCUMENT IS STRICTLY PROHIBITED AND ANY INFRENGEMENT THEREUPON MAY BE SUBJECT TO LEGAL ACTION.</small></p>		<p>JOB NO.: 17171S/18253S/ 20376S/21118S</p>		<p>REV.: 3</p>	

 <p>6/18/21</p>	 <p>6/18/21</p>	 <p>6/18/21</p>	
 <p>6/18/21</p>	<p>Professional Certification. I hereby certify that these documents were prepared or approved by me, and that I am a duly licensed professional engineer under the laws of the State of Maryland, License No. 49744, Expiration Date <u>6/18/22</u></p>		
 <p>6/18/21</p>	 <p>6/18/21</p>		
 <p>6/18/21</p>	 <p>6/18/21</p>		
 <p>6/18/21</p>	<p>WAYNE SHERIDAN MOORE No. 12395 6/18/21 REGISTERED PROFESSIONAL ENGINEER (STRUCTURAL)</p>		
<p>MOORE AND ASSOCIATES ENGINEERING AND CONSULTING, INC.</p>		<p>DRAWN BY: JG CHECKED BY: PDM</p>	<p>CARPORT CENTRAL, INC. 737 SOUTH MAIN STREET MOUNT AIRY, NC 27030 30'-0" x 16'-0" ENCLOSED STRUCTURE</p>
<p><small>THIS DOCUMENT IS THE PROPERTY OF MOORE AND ASSOCIATES ENGINEERING AND CONSULTING. THE UNAUTHORIZED REPRODUCTION, COPYING, OR OTHERWISE USE OF THIS DOCUMENT IS STRICTLY PROHIBITED AND ANY INFRINGEMENT THEREUPON MAY BE SUBJECT TO LEGAL ACTION.</small></p>		<p>PROJECT MGR: WSM CLIENT: CC</p>	<p>DATE: 6-17-21 SHT. 1A SCALE: NTS DWG. NO: SK-3 JOB NO: 1717S/18253S/ 20376S/2118S REV: 3</p>

DRAWING INDEX

SHEET 1	PE SEAL COVER SHEET (1 OF 2)
SHEET 1A	PE SEAL COVER SHEET (2 OF 2)
SHEET 2	DRAWING INDEX
SHEET 3	INSTALLATION NOTES AND SPECIFICATIONS
SHEET 3A	LIST OF APPLICABLE BUILDING CODE
SHEET 4	TYPICAL SIDE AND END ELEVATIONS
SHEET 5	TYPICAL RAFTER/COLUMN END AND SIDE FRAMING SECTION (BOX EAVE RAFTER)
SHEET 6	COLUMN CONNECTION DETAILS
SHEET 7	TYPICAL RAFTER/COLUMN END AND SIDE FRAMING SECTION (BOW RAFTER)
SHEET 8	COLUMN CONNECTION DETAILS
SHEET 9	BASE RAIL ANCHORAGE OPTIONS
SHEET 9A	BASE RAIL ANCHORAGE OPTION
SHEET 10	BOX EAVE RAFTER END WALL AND SIDE WALL FRAMING SECTIONS
SHEET 11	BOW RAFTER END WALL AND SIDE WALL FRAMING SECTIONS
SHEET 12	CONNECTION DETAILS
SHEET 13	CONNECTION DETAILS
SHEET 14	CONNECTION DETAILS
SHEET 15	BOX EAVE RAFTER LEAN-TO OPTIONS
SHEET 16	BOW RAFTER LEAN-TO OPTION
SHEET 17	BOX EAVE RAFTER VERTICAL ROOF OPTION
SHEET 18	OPTIONAL BASE RAIL ON GRADE APPLICATION
SHEET 19	OPTIONAL BASE RAIL ON TIMBER BEAM
SHEET 20	OPTIONAL CONCRETE STRIP FOOTING
SHEET 21	SIDE WALL AND END WALL HEADER OPTIONS

** CarportCentral Associate Manufacturer Or Customer Use Only**

MOORE AND ASSOCIATES ENGINEERING AND CONSULTING, INC.	DRAWN BY: JG	CARPORT CENTRAL, INC. 737 SOUTH MAIN STREET MOUNT AIRY, NC 27030 30'-0" x 16'-0" ENCLOSED STRUCTURE		
	CHECKED BY: PDH	JOB NO: 17171S/18253S/ 20376S/21116S		
THIS DOCUMENT IS THE PROPERTY OF MOORE AND ASSOCIATES ENGINEERING AND CONSULTING. THE UNAUTHORIZED REPRODUCTION, COPYING, OR OTHERWISE USE OF THIS DOCUMENT IS STRICTLY PROHIBITED AND ANY IMPROVEMENT THEREUPON MAY BE SUBJECT TO LEGAL ACTION.	PROJECT MGR: WSM	DATE: 6-17-21	SCALE: NTS	REV: 3
	CLIENT: CC	SHT. 2	DWG. NO: SK-3	

INSTALLATION NOTES AND SPECIFICATIONS

- 1 DESIGN IS FOR MAXIMUM 30'-0" WIDE x 16'-0" EAVE HEIGHT ENCLOSED STRUCTURES
- 2 DESIGN WAS DONE IN ACCORDANCE WITH ALL APPLICABLE BUILDING CODES LISTED ON SHEET 3A
- 3 DESIGN LOADS ARE AS FOLLOWS:
 - A) DEAD LOAD = 15 PSF
 - B) LIVE LOAD = 12 PSF
 - C) GROUND SNOW LOAD = 30 PSF ($\leq 26'-0"$), 35 PSF ($26'-0" < W \leq 30'-0"$)

(NOTE: UNBALANCED SNOW LOADS DUE TO DRIFTING HAVE NOT BEEN EVALUATED)
4. ULTIMATE WIND SPEED = ≤ 145 MPH (NOMINAL WIND SPEED = ≤ 112 MPH) UNLESS NOT OTHERWISE)
- 5 MAXIMUM RAFTER/COLUMN AND END COLUMN SPACING = 50 FEET (UNLESS NOTED OTHERWISE)
- 6 END WALL COLUMNS (POST) ARE EQUIVALENT TO SIDE WALL COLUMNS (POST) UNLESS NOTED OTHERWISE
- 7 LOW HAZARD RISK CATEGORY I.
8. WIND EXPOSURE CATEGORY B
- 9 SPECIFICATIONS APPLICABLE TO 29 GAUGE METAL PANELS FASTENED DIRECTLY TO 2 1/2" x 2 1/2" - 14 GAUGE TUBE STEEL JOIST FRAMING MEMBERS (UNLESS NOTED OTHERWISE)
- 10 AVERAGE FASTENER SPACING ON-CENTERS ALONG RAFTERS OR HAT CHANNELS, AND COLUMNS (INTERIOR AND EDGE DISTANCE) = 8 INCHES
11. FASTENERS CONSIST OF 1/4"x3/4" (UNLESS OTHERWISE NOTED) SELF-DRILLING FASTENER (SDF), USE CONTROL SEAL WASHER WITH EXTERIOR FASTENERS. SPECIFICATIONS APPLICABLE ONLY FOR MEAN ROOF HEIGHT OF 20 FEET OR LESS, AND ROOF SLOPES OF 14° (3:12) PITCH OR LESS. SPACING REQUIREMENTS FOR OTHER ROOF HEIGHTS AND/OR SLOPES MAY VARY, ROOF SLOPES LESS THAN 3:12 REQUIRE USE OF LAP JOINT SEALANT
12. ANCHORS SHALL BE INSTALLED THROUGH BASE RAIL WITHIN 6" OF EACH COLUMN
- 13 STANDARD GROUND ANCHORS (SOIL NAILS) CONSIST OF #4 REBAR W/ WELDED NUT x 36" LONG IN SUITABLE SOILS. OPTIONAL ANCHORAGE MAY BE USED IN SUITABLE SOILS AND MUST BE USED FOR WIND SPEEDS ≤ 145 MPH. OPTIONAL ANCHORAGE MAY BE USED IN SUITABLE SOILS AND MUST BE USED IN UNSUITABLE SOILS AND FOR WIND SPEEDS > 145 MPH AS NOTED. COORDINATE WITH LOCAL CODES/ORDINANCES REGARDING MINIMUM LENGTH FOR FROST DEPTH PROTECTION.
- 14 WIND FORCES GOVERN OVER SEISMIC FORCES. SEISMIC PARAMETERS ANALYZED ARE:
 SOIL SITE CLASS = D
 RISK CATEGORY I
 $R = 3.25$
 $S_{DS} = 2.039 g$
 $S_{D1} = 1.258 g$
 $I_e = 1.0$
 $V = C_s W$

** CarportCentral Associate Manufacturer Or Customer Use Only**

MOORE AND ASSOCIATES ENGINEERING AND CONSULTING, INC.	DRAWN BY: JG	CARPORT CENTRAL, INC. 737 SOUTH MAIN STREET MOUNT AIRY, NC 27030 30'-0" x 16'-0" ENCLOSED STRUCTURE		
	CHECKED BY: PDH			
PROJECT MGR: WSM	DATE: 6-17-21	SCALE: NTS	JOB NO: 1717S/18253S/ 20376S/21116S	
CLIENT: CC	SHT. 3	DWG. NO: SK-3	REV: 3	

THIS DOCUMENT IS THE PROPERTY OF MOORE AND ASSOCIATES ENGINEERING AND CONSULTING. THE UNAUTHORIZED REPRODUCTION, COPYING, OR OTHERWISE USE OF THIS DOCUMENT IS STRICTLY PROHIBITED AND ANY INFRACTION THEREOF MAY BE SUBJECT TO LEGAL ACTION.

LIST OF APPLICABLE BUILDING CODES

- 2018 INTERNATIONAL BUILDING CODE (IBC 2018)
- 2015 INTERNATIONAL BUILDING CODE (IBC 2015)
- 2012 INTERNATIONAL BUILDING CODE (IBC 2012)
- 2009 INTERNATIONAL BUILDING CODE (IBC 2009)
- 2006 INTERNATIONAL BUILDING CODE (IBC 2006)
- BUILDING CODE 2015 OF ALABAMA
(ADOPTS THE IBC 2015 WITH AMENDMENTS)
- 2015 IBC PORTION OF THE 2018 CT STATE BUILDING CODE
(ADOPTS THE IBC 2015 WITH AMENDMENTS)
- COLORADO: IBC 2015, IBC 2018
(DEPENDENT UPON LOCAL JURISDICTION)
- 2020 FLORIDA BUILDING CODE, 7TH EDITION
- GEORGIA STATE MINIMUM STANDARD BUILDING CODE
(ADOPTS THE IBC 2015 WITH AMENDMENTS)
- INDIANA BUILDING CODE, 2014 EDITION
(ADOPTS THE IBC 2012 WITH AMENDMENTS)
- BUILDING CODE 2018 OF KANSAS
(ADOPTS THE IBC 2018 WITH AMENDMENTS)
- 2018 KENTUCKY BUILDING CODE
(ADOPTS THE IBC 2015 WITH AMENDMENTS)
- BUILDING CODE 2015 OF LOUISIANA
(ADOPTS THE IBC 2015 WITH AMENDMENTS)
- MA STATE BUILDING CODE, 9TH EDITION
(ADOPTS THE IBC 2015 WITH AMENDMENTS)
- BUILDING CODE 2018 OF MARYLAND
(ADOPTS THE IBC 2018 WITH AMENDMENTS)
- BUILDING CODE 2015 OF NEW MEXICO
(ADOPTS THE IBC 2015 WITH AMENDMENTS)
- 2020 BUILDING CODE OF NEW YORK STATE
(ADOPTS THE IBC 2018 WITH AMENDMENTS)
- 2018 NORTH CAROLINA BUILDING CODE
(ADOPTS THE IBC 2015 WITH AMENDMENTS)
- OHIO BUILDING CODE 2017
(ADOPTS THE IBC 2015 WITH AMENDMENTS)
- BUILDING CODE 2015 OF OKLAHOMA
(ADOPTS THE IBC 2015 WITH AMENDMENTS)
- BUILDING CODE 2015 OF PENNSYLVANIA
(ADOPTS THE IBC 2015 WITH AMENDMENTS)
- 2019 RHODE ISLAND BUILDING CODE
(ADOPTS THE IBC 2015 WITH AMENDMENTS)
- 2018 SOUTH CAROLINA BUILDING CODE
(ADOPTS THE IBC 2015 WITH AMENDMENTS)
- BUILDING CODE 2012 OF TENNESSEE
(ADOPTS THE IBC 2012 WITH AMENDMENTS)
- * IBC 2012, IBC 2018
BUILDING CODE OF THE TEXAS INDUSTRIALIZED
HOUSING AND BUILDINGS PROGRAM
(ADOPTS THE IBC 2012 WITH AMENDMENTS)

CarportCentral Associate Manufacturer Or Customer Use Only**

MOORE AND ASSOCIATES ENGINEERING AND CONSULTING, INC.	DRAWN BY: JG	CARPORT CENTRAL, INC. 737 SOUTH MAIN STREET MOUNT AIRY, NC 27030 30'-0" x 6'-0" ENCLOSED STRUCTURE		
	CHECKED BY: PDH	PROJECT MGR: WSM	DATE: 6-17-21	SCALE: NTS
THIS DOCUMENT IS THE PROPERTY OF MOORE AND ASSOCIATES ENGINEERING AND CONSULTING. THE UNAUTHORIZED REPRODUCTION, COPYING, OR OTHERWISE USE OF THIS DOCUMENT IS STRICTLY PROHIBITED AND ANY INFRINGEMENT THEREUPON MAY BE SUBJECT TO LEGAL ACTION.	CLIENT: CC	SHT. 3A	DWG. NO: SK-3	JOB NO: 17171S/18239S/ 20376S/21118S REV: 3

BOX EAVE FRAME RAFTER STRUCTURE (Sheets 5, 6, 9, 9A, 10, 12, 13, 14, 15, 18, 19, 20 AND 21)

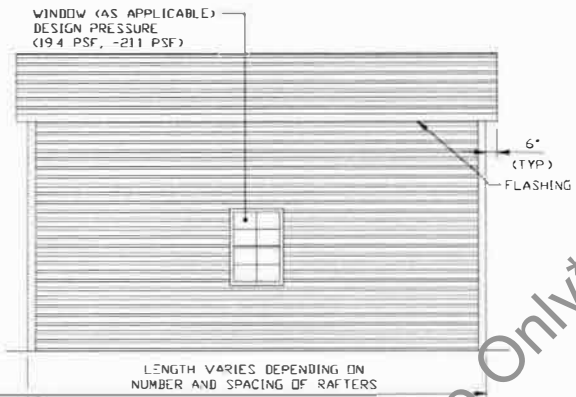
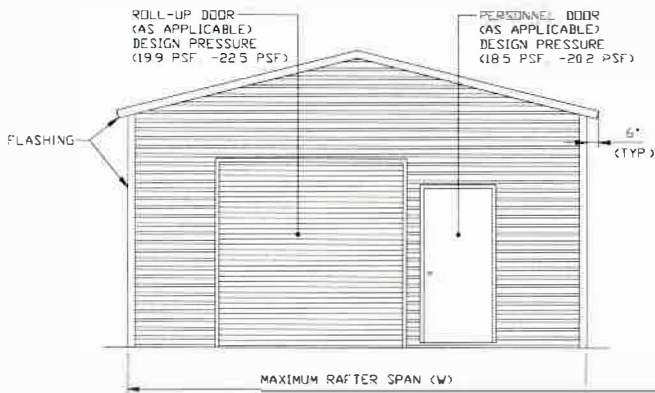

TYPICAL END ELEVATION-HORIZONTAL ROOF

SCALE: NTS

TYPICAL SIDE ELEVATION-HORIZONTAL ROOF

SCALE: NTS

BOW FRAME RAFTER STRUCTURE (Sheets 7, 8, 9, 9A, 11, 12, 13, 14, 16, 18, 19, 20 AND 21)

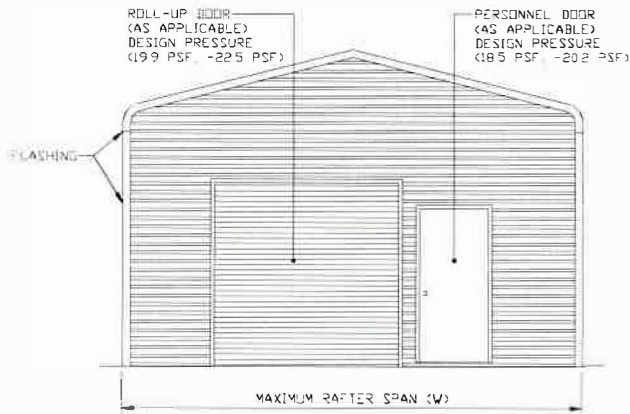

TYPICAL END ELEVATION

SCALE: NTS

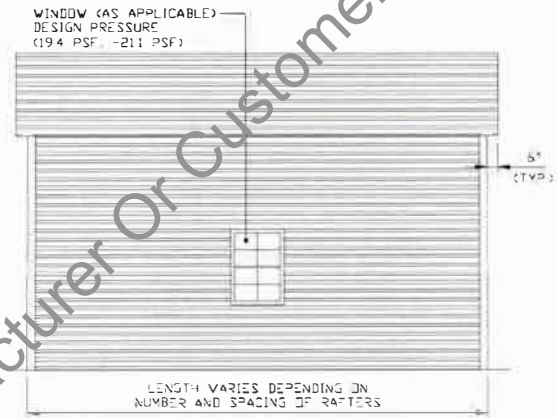

TYPICAL END ELEVATION

SCALE: NTS

**** CarportCentral Associate Manufacturer Or Customer Use Only****

**MOORE AND ASSOCIATES
ENGINEERING AND CONSULTING, INC.**

DRAWN BY: JG

CHECKED BY: PDH

PROJECT MGR: WSM

CLIENT: CC

**CARPOT CENTRAL, INC.
737 SOUTH MAIN STREET
MOUNT AIRY, NC 27030**

30'-0" x 16'-0" ENCLOSED STRUCTURE

DATE: 6-17-21

SHT. 4

SCALE: NTS

DWG. NO: SK-3

**JOB NO: 17171S/18253S/
20376S/21118S**

REV: 3

THIS DOCUMENT IS THE PROPERTY OF MOORE AND ASSOCIATES ENGINEERING AND CONSULTING. THE UNAUTHORIZED REPRODUCTION, COPYING, OR OTHERWISE USE OF THIS DOCUMENT IS STRICTLY PROHIBITED AND ANY INFRINGEMENT THEREUPON MAY BE SUBJECT TO LEGAL ACTION.

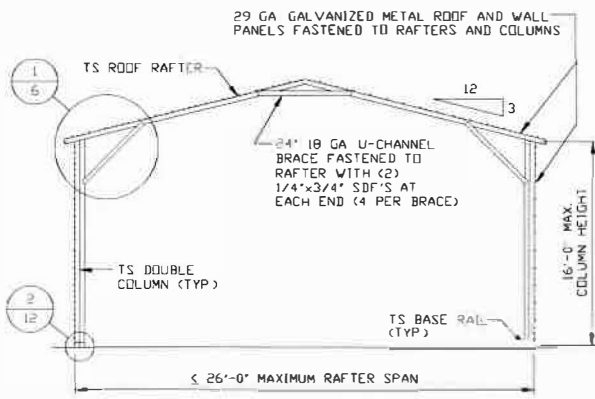

TYPICAL RAFTER/COLUMN END FRAME SECTION
SCALE: NTS

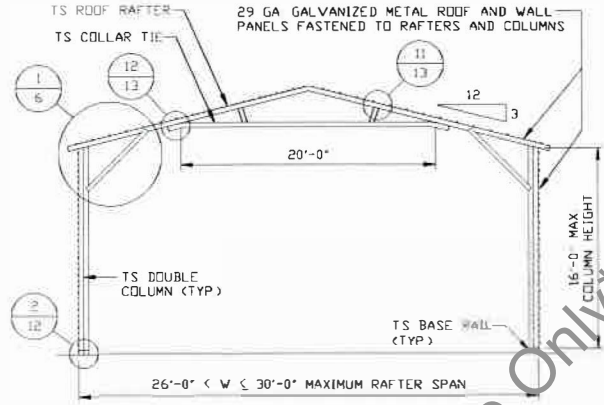

TYPICAL RAFTER/COLUMN END FRAME SECTION
SCALE: NTS

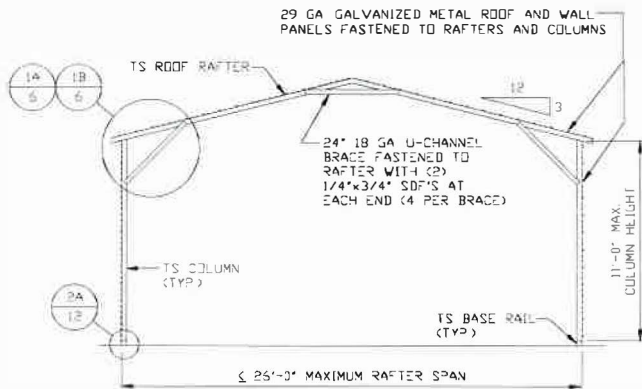

TYPICAL RAFTER/COLUMN END FRAME SECTION
SCALE: NTS

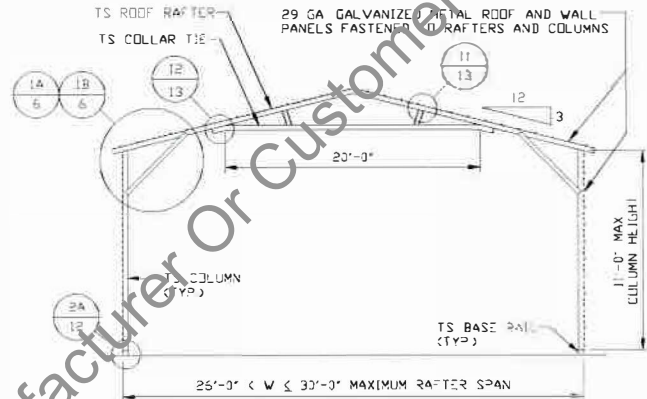

TYPICAL RAFTER/COLUMN END FRAME SECTION
SCALE: NTS

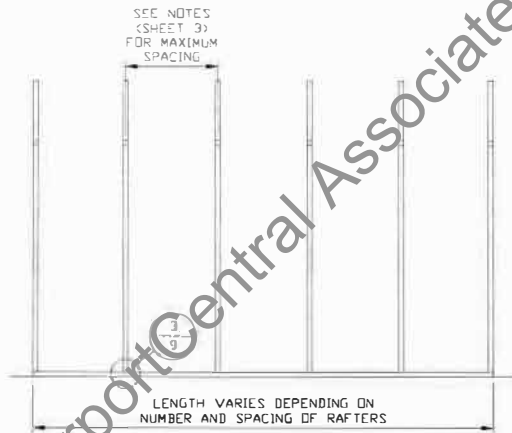

TYPICAL RAFTER/COLUMN SIDE FRAMING SECTION
SCALE: NTS

**MOORE AND ASSOCIATES
ENGINEERING AND CONSULTING, INC.**

DRAWN BY: JG

CHECKED BY: PDH

PROJECT MGR: WSM

CLIENT: CC

CARPOT CENTRAL, INC.
737 SOUTH MAIN STREET
MOUNT AIRY, NC 27030
30'-0" x 16'-0" ENCLOSED STRUCTURE

DATE: 6-17-21

SHT. 5

SCALE: NTS

DWG. NO: SK-3

JOB NO: 17171S/18253S/
20376S/21118S

REV: 3

THIS DOCUMENT IS THE PROPERTY OF MOORE AND ASSOCIATES ENGINEERING AND CONSULTING. THE UNAUTHORIZED REPRODUCTION, COPYING, OR OTHERWISE USE OF THIS DOCUMENT IS STRICTLY PROHIBITED AND ANY INFREEMENT THEREUPON MAY BE SUBJECT TO LEGAL ACTION.

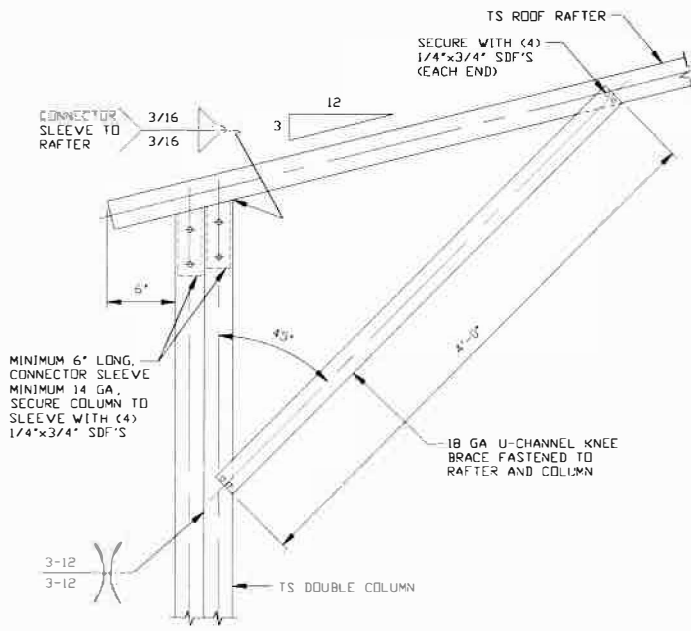

BOX EAVE RAFTER COLUMN CONNECTION DETAIL FOR HEIGHTS 11'-0" < TO ≤ 16'-0"

1

SCALE: NTS

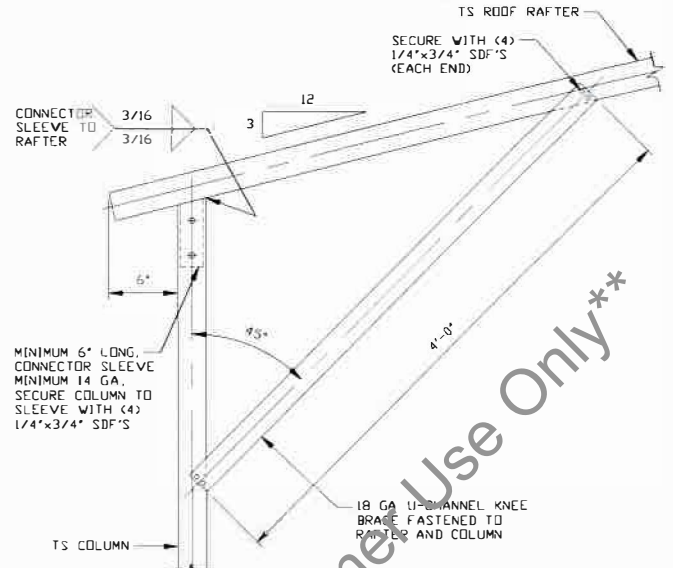

BOX EAVE RAFTER COLUMN CONNECTION DETAIL FOR HEIGHTS 9'-0" < TO ≤ 11'-0"

1A

SCALE: NTS

NOTE: MAXIMUM COLUMN HEIGHT IS 12'-0" FOR WIND SPEEDS ≤ 128 MPH.

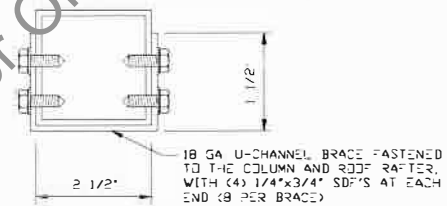

BRACE SECTION

SCALE: NTS

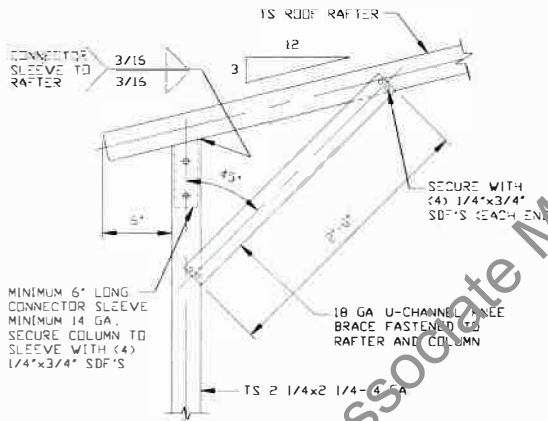

BOX EAVE RAFTER COLUMN CONNECTION DETAIL FOR HEIGHTS < 9'-0"

1B

SCALE: NTS

NOTE: KNEE BRACE MUST BE 4'-0" FOR 30'-0" WIDE STRUCTURES

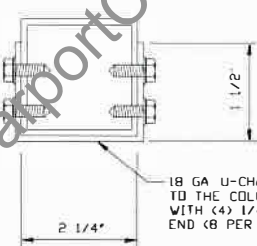

BRACE SECTION

SCALE: NTS

MOORE AND ASSOCIATES ENGINEERING AND CONSULTING, INC.

DRAWN BY: JG

CHECKED BY: PDH

PROJECT MGR: VSM

CLIENT: CC

CARPOT CENTRAL, INC.
737 SOUTH MAIN STREET
MOUNT AIRY, NC 27030

30'-0" x 16'-0" ENCLOSED STRUCTURE

DATE: 6-17-21

SHT. 6

SCALE: NTS

DWG. NO: SK-3

**JOB NO: 17171S/18253S/
20376S/21118S**

REV: 3

THIS DOCUMENT IS THE PROPERTY OF MOORE AND ASSOCIATES ENGINEERING AND CONSULTING. THE UNAUTHORIZED REPRODUCTION, COPYING, OR OTHERWISE USE OF THIS DOCUMENT IS STRICTLY PROHIBITED AND ANY INFREEMENT THEREUPON MAY BE SUBJECT TO LEGAL ACTION.

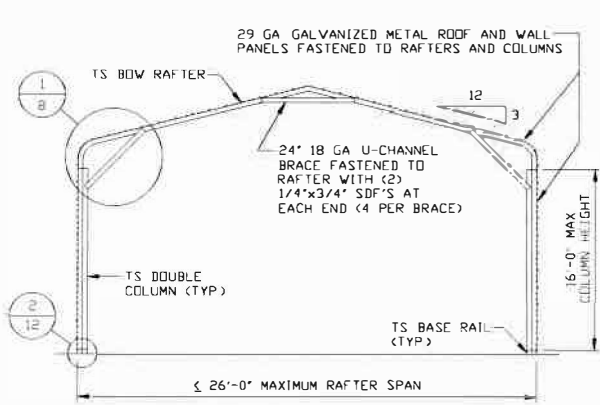

TYPICAL RAFTER/COLUMN END FRAME SECTION
SCALE: NTS

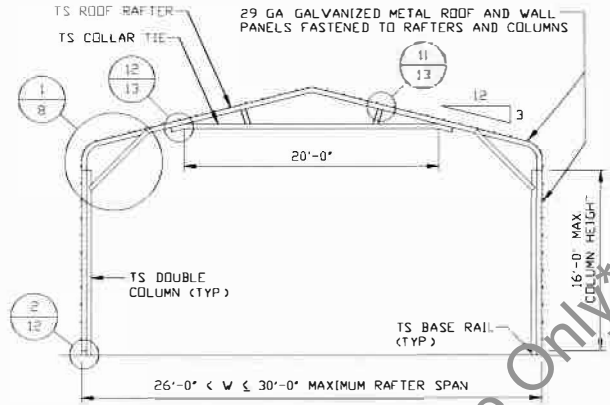

TYPICAL RAFTER/COLUMN END FRAME SECTION
SCALE: NTS

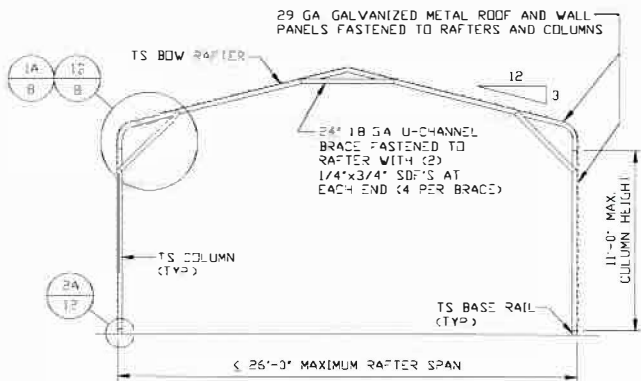

TYPICAL RAFTER/COLUMN END FRAME SECTION
SCALE: NTS

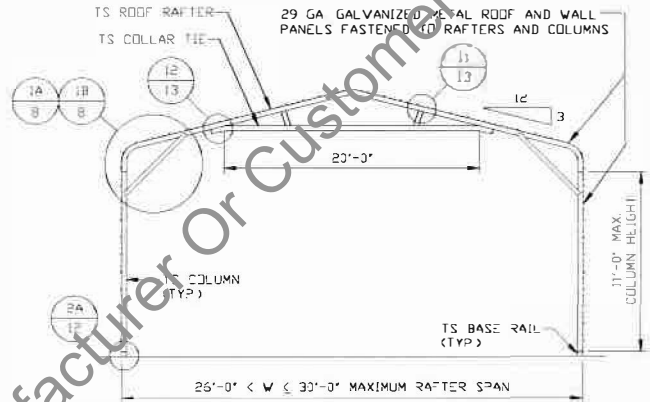

TYPICAL RAFTER/COLUMN END FRAME SECTION
SCALE: NTS

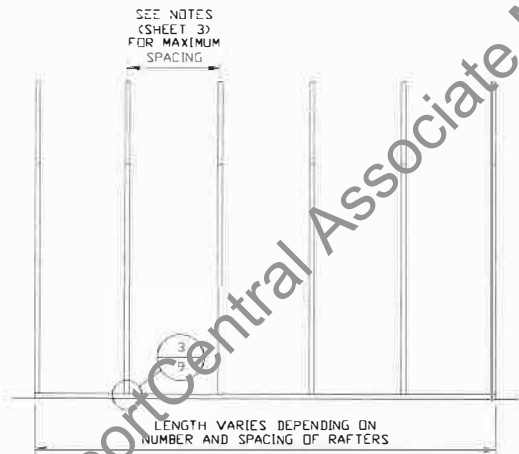

TYPICAL RAFTER/COLUMN FRAMING SIDE SECTION
SCALE: NTS

**MOORE AND ASSOCIATES
ENGINEERING AND CONSULTING, INC.**

DRAWN BY: JG

CHECKED BY: PDH

PROJECT MGR: WSM

CLIENT: CC

CARPORIT CENTRAL, INC.
737 SOUTH MAIN STREET
MOUNT AIRY, NC 27030
30'-0" x 16'-0" ENCLOSED STRUCTURE

DATE: 6-17-21

SCALE: NTS

SHT. 7

DWG. NO SK-3

JOB NO: 17171S/18253S/
20376S/21118S

REV: 3

THIS DOCUMENT IS THE PROPERTY OF MOORE AND ASSOCIATES ENGINEERING AND CONSULTING. THE UNAUTHORIZED REPRODUCTION, COPYING, OR OTHERWISE USE OF THIS DOCUMENT IS STRICTLY PROHIBITED AND ANY INFRINGEMENT THEREUPON MAY BE SUBJECT TO LEGAL ACTION.

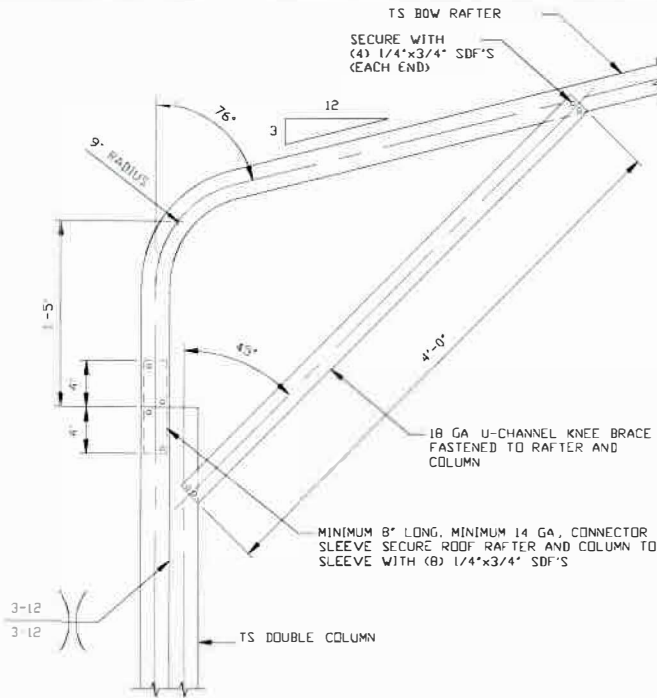

BOW RAFTER COLUMN CONNECTION DETAIL FOR HEIGHTS 11'-0" < TO ≤ 16'-0"
SCALE: NTS

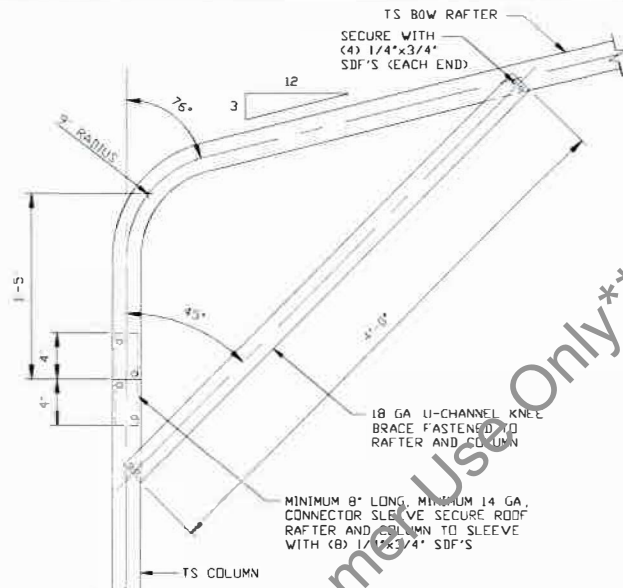

BOW RAFTER COLUMN CONNECTION DETAIL FOR HEIGHTS 9'-0" < TO ≤ 11'-0"
SCALE: NTS
NOTE: MAXIMUM COLUMN HEIGHT IS 12'-0" FOR WIND SPEEDS ≤ 128 MPH.

1A

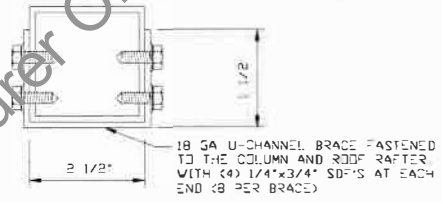

BRACE SECTION
SCALE: NTS

1

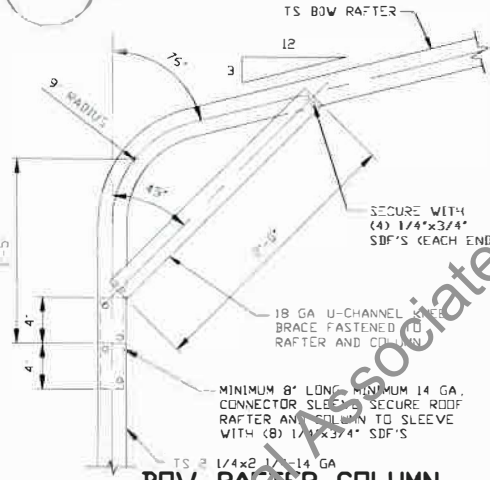

BOW RAFTER COLUMN CONNECTION DETAIL FOR HEIGHTS ≤ 9'-0"
SCALE: NTS
NOTE: KNEE BRACE MUST BE 4'-0" FOR 30'-0" WIDE STRUCTURES

1B

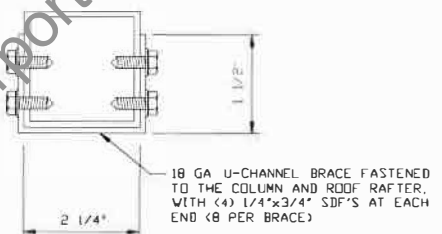

BRACE SECTION
SCALE: NTS

MOORE AND ASSOCIATES ENGINEERING AND CONSULTING, INC.

DRAWN BY: JG
CHECKED BY: PDH
PROJECT MGR: WSH
CLIENT: CC

CARPORIT CENTRAL, INC.
737 SOUTH MAIN STREET
MOUNT AIRY, NC 27030
30'-0" x 16'-0" ENCLOSED STRUCTURE
DATE: 6-17-21
SCALE: NTS
SHT. 8
DWG. NO.: SK-3
JOB NO.: 17171S/18253S/20376S/21118S
REV.: 3

THIS DOCUMENT IS THE PROPERTY OF MOORE AND ASSOCIATES ENGINEERING AND CONSULTING, INC. UNAUTHORIZED REPRODUCTION, COPYING, OR OTHERWISE USE OF THIS DOCUMENT IS STRICTLY PROHIBITED AND ANY INFRINGEMENT THEREUPON MAY BE SUBJECT TO LEGAL ACTION.

BASE RAIL ANCHORAGE OPTIONS

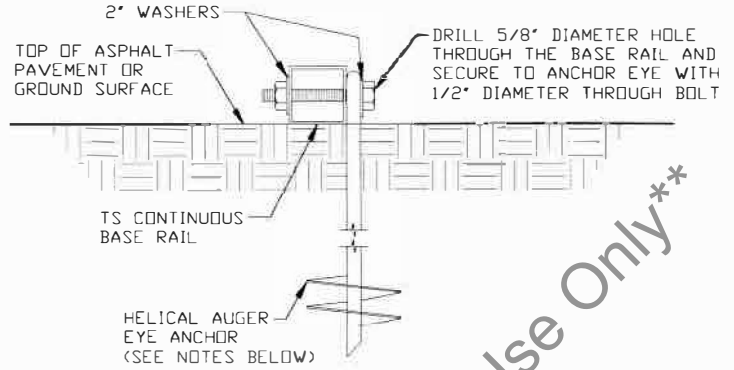
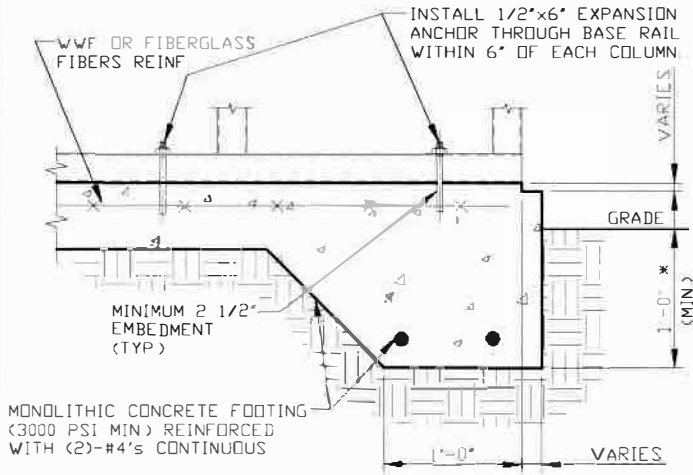

3A

**CONCRETE MONOLITHIC SLAB
BASE RAIL ANCHORAGE**

SCALE: NTS
MINIMUM ANCHOR EDGE DISTANCE IS 4"
* COORDINATE WITH LOCAL BUILDING CODE/ORD
REGARDING MINIMUM FROST DEPTH (LENGTH)

3B

HELICAL AUGER ANCHORAGE

SCALE: NTS (CAN BE USED FOR ASPHALT)
* COORDINATE WITH LOCAL BUILDING CODE/ORD
REGARDING MINIMUM FROST DEPTH (LENGTH)

GENERAL NOTES

NOTE CONCRETE MONOLITHIC SLAB DESIGN BASED ON MINIMUM SOIL BEARING CAPACITY OF 1,500 PSF

CONCRETE:

CONCRETE SHALL HAVE A MINIMUM SPECIFIED COMPRESSIVE STRENGTH OF 3,000 PSI AT 28 DAYS

COVER OVER REINFORCING STEEL:

FOR FOUNDATIONS, MINIMUM CONCRETE COVER OVER REINFORCING BARS SHALL BE PER ACI-318:
3" IN FOUNDATIONS WHERE THE CONCRETE IS CAST AGAINST AND PERMANENTLY IN CONTACT WITH THE EARTH OR EXPOSED TO THE EARTH OR WEATHER, AND 1 1/2" ELSEWHERE

REINFORCING STEEL:

THE TURNDOWN REINFORCING STEEL SHALL BE ASTM A615 GRADE 60 THE SLAB REINFORCEMENT SHALL BE WELDED WIRE FABRIC MEETING ASTM A185 OR FIBERGLASS FIBER REINFORCEMENT

REINFORCEMENT MAY BE BENT IN THE SHOP OR THE FIELD PROVIDED:

- 1 REINFORCEMENT IS BENT COLD
- 2 THE DIAMETER OF THE BEND, MEASURED ON THE INSIDE OF THE BAR, IS NOT LESS THAN SIX-BAR DIAMETERS
- 3 REINFORCEMENT PARTIALLY EMBEDDED IN CONCRETE SHALL NOT BE FIELD BENT

HELICAL AUGER ANCHOR NOTES:

- 1 FOR VERY DENSE AND/OR CEMENTED SANDS, COARSE GRAVEL AND COBBLES, CALICHE, PRELOADED SILTS AND CLAYS, USE MINIMUM (2) 4" HELICES WITH MINIMUM 30" EMBEDMENT OR SINGLE 6" HELIX WITH MINIMUM 50" EMBEDMENT
- 2 FOR CORAL USE MINIMUM (2) 4" HELICES WITH MINIMUM 30" EMBEDMENT OR SINGLE 6" HELIX WITH MINIMUM 50" EMBEDMENT
- 3 FOR MEDIUM DENSE COARSE SANDS, SANDY GRAVELS, VERY STIFF SILTS AND CLAYS USE MINIMUM (2) 4" HELICES WITH MINIMUM 30" EMBEDMENT OR SINGLE 6" HELIX WITH MINIMUM 50" EMBEDMENT
- 4 FOR LOOSE TO MEDIUM DENSE SANDS, FIRM TO STIFF CLAYS AND SILTS ALLUVIAL FILL, USE MINIMUM (2) 6" HELICES WITH MINIMUM 50" EMBEDMENT
- 5 FOR VERY LOOSE TO MEDIUM DENSE SANDS, FIRM TO STIFFER CLAYS AND SILTS, ALLUVIAL FILL, USE MINIMUM (2) 8" HELICES WITH MINIMUM 60" EMBEDMENT

**MOORE AND ASSOCIATES
ENGINEERING AND CONSULTING, INC.**

DRAWN BY: JG

CHECKED BY: PDH

PROJECT MGR: WSM

CLIENT: CC

CARPORIT CENTRAL, INC.
737 SOUTH MAIN STREET
MOUNT AIRY, NC 27030
30'-0" x 16'-0" ENCLOSED STRUCTURE

DATE: 6-17-21

SHT. 9

SCALE: NTS

DWG. NO: SK-3

**JOB NO: 1717S/18253S/
20376S/21118S**

REV: 3

THIS DOCUMENT IS THE PROPERTY OF MOORE AND ASSOCIATES ENGINEERING AND CONSULTING. THE UNAUTHORIZED REPRODUCTION, COPYING, OR OTHERWISE USE OF THIS DOCUMENT IS STRICTLY PROHIBITED AND ANY INFRINGEMENT THEREUPON MAY BE SUBJECT TO LEGAL ACTION.

BASE RAIL ANCHORAGE OPTION

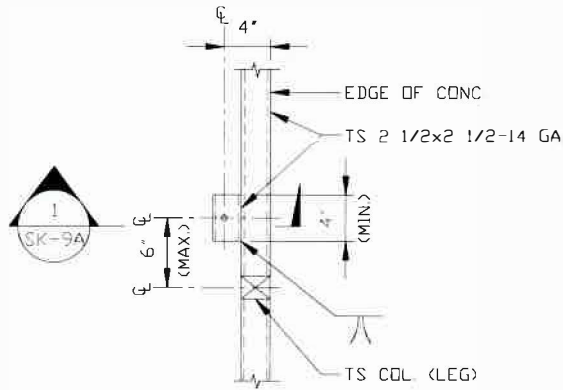

TYPICAL ANCHOR DETAIL WHEN BASE RAIL IS NEAR EDGE OF CONCRETE

SCALE: NTS

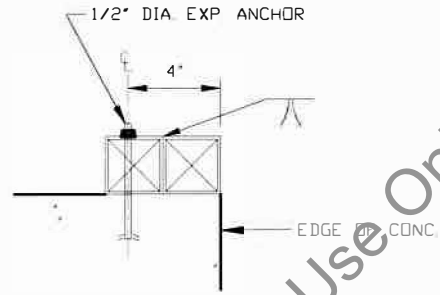

SECTION
SCALE: NTS

**** CarportCentral Associate Manufacturer Or Customer Use Only****

**MOORE AND ASSOCIATES
ENGINEERING AND CONSULTING, INC.**

DRAWN BY: JG

CHECKED BY: PDH

PROJECT MGR: WSM

CLIENT: CC

CARPOT CENTRAL, INC.
737 SOUTH MAIN STREET
MOUNT AIRY, NC 27030
30'-0" x 16'-0" ENCLOSED STRUCTURE

DATE: 6-17-21

SHT. 9A

SCALE: NTS

DWG. NO: SK-3

**JOB NO: 1717S/18253S/
20376S/21118S**

REV: 3

THIS DOCUMENT IS THE PROPERTY OF MOORE AND ASSOCIATES ENGINEERING AND CONSULTING. THE UNAUTHORIZED REPRODUCTION, COPYING, OR OTHERWISE USE OF THIS DOCUMENT IS STRICTLY PROHIBITED AND ANY INFRINGEMENT THEREUPON MAY BE SUBJECT TO LEGAL ACTION.

BOX EAVE RAFTER END WALL AND SIDE WALL FRAMING SECTIONS

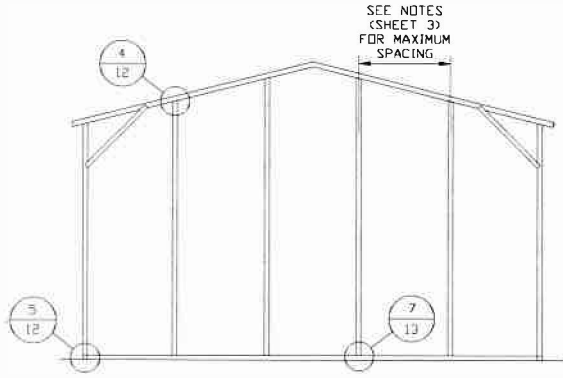

TYPICAL BOX EAVE RAFTER END WALL FRAMING SECTION

SCALE: NTS

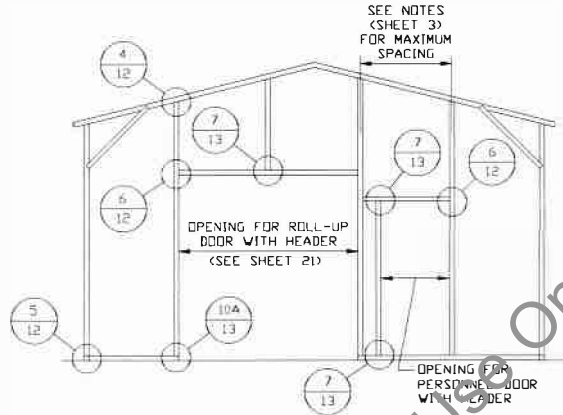

TYPICAL BOX EAVE RAFTER END WALL OPENINGS FRAMING SECTION

SCALE: NTS

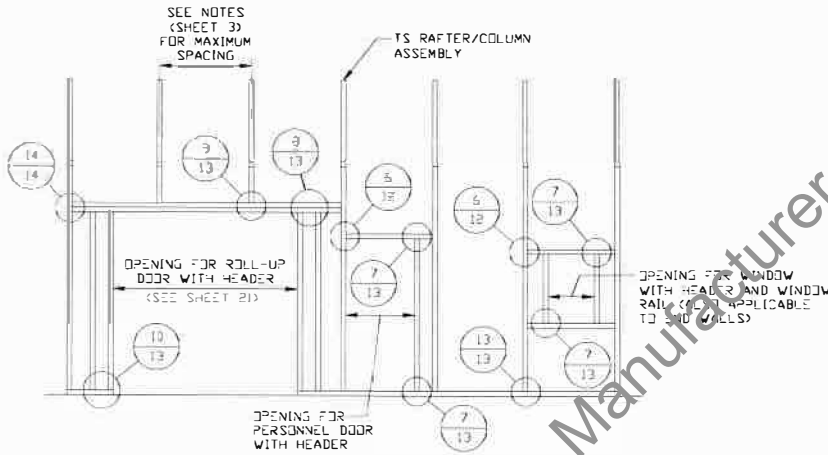

TYPICAL BOX EAVE RAFTER SIDE WALL OPENINGS FRAMING SECTION

SCALE: NTS

**** CarportCentral Associate Manufacturer Or Customer Use Only****

**MOORE AND ASSOCIATES
ENGINEERING AND CONSULTING, INC.**

DRAWN BY: JG

CHECKED BY: PDH

PROJECT MGR: WSM

CLIENT: CC

CARPORIT CENTRAL, INC.
737 SOUTH MAIN STREET
MOUNT AIRY, NC 27030

30'-0" x 16'-0" ENCLOSED STRUCTURE

DATE: 6-17-21

SHT. 10

SCALE: NTS

DWG. NO: SK-3

**JOB NO: 17171S/18253S/
20376S/21118S**

REV: 3

THIS DOCUMENT IS THE PROPERTY OF MOORE AND ASSOCIATES ENGINEERING AND CONSULTING. THE UNAUTHORIZED REPRODUCTION, COPYING, OR OTHERWISE USE OF THIS DOCUMENT IS STRICTLY PROHIBITED AND ANY INFRINGEMENT THEREUPON MAY BE SUBJECT TO LEGAL ACTION.

BOW RAFTER END WALL AND SIDE WALL FRAMING SECTIONS

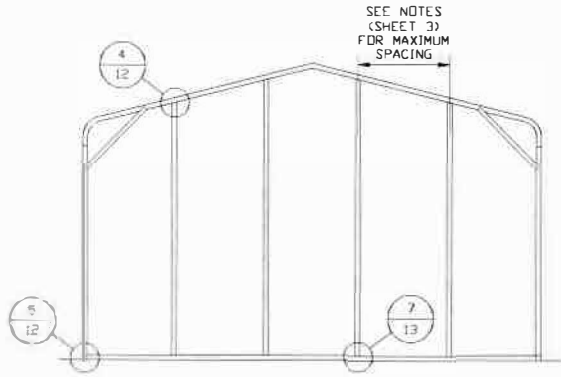

**TYPICAL BOW RAFTER
END WALL FRAMING SECTION**

SCALE: NTS

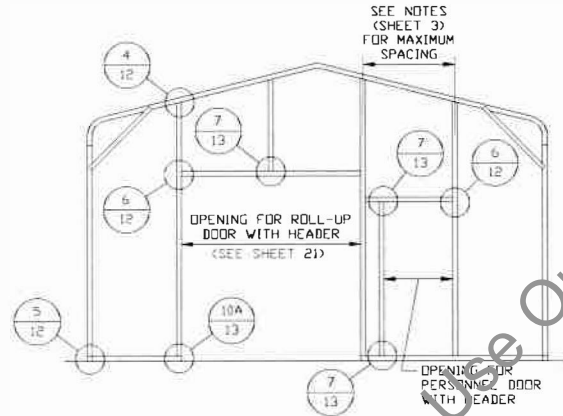

**TYPICAL BOW RAFTER END
WALL OPENINGS FRAMING SECTION**

SCALE: NTS

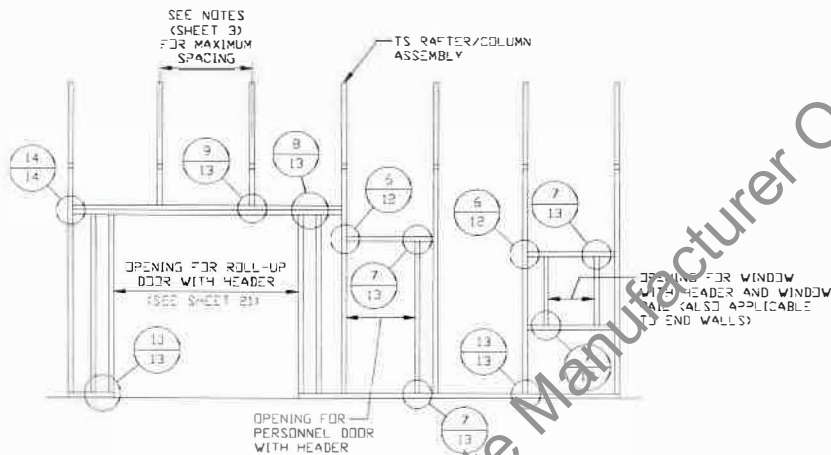

**TYPICAL BOW RAFTER SIDE
WALL OPENINGS FRAMING SECTION**

SCALE: NTS

**** CarportCentral Associate Manufacturer Or Customer Use Only****

**MOORE AND ASSOCIATES
ENGINEERING AND CONSULTING, INC.**

DRAWN BY: JG

CHECKED BY: PDH

PROJECT MGR: WSM

CLIENT: CC

**CARPORNT CENTRAL, INC.
737 SOUTH MAIN STREET
MOUNT AIRY, NC 27030
30'-0" x 16'-0" ENCLOSED STRUCTURE**

DATE: 6-17-21

SHT. 11

SCALE: NTS

DWG. NO: SK-3

**JOB NO: 17171S/18253S/
20376S/21118S**

REV: 3

THIS DOCUMENT IS THE PROPERTY OF MOORE AND ASSOCIATES ENGINEERING AND CONSULTING. THE UNAUTHORIZED REPRODUCTION, COPYING, OR OTHERWISE USE OF THIS DOCUMENT IS STRICTLY PROHIBITED AND ANY INFRACTION THEREOF MAY BE SUBJECT TO LEGAL ACTION.

CONNECTION DETAILS

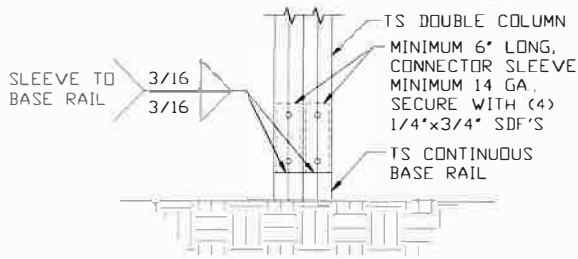

2 RAFTER COLUMN/BASE RAIL CONNECTION DETAIL
SCALE: NTS

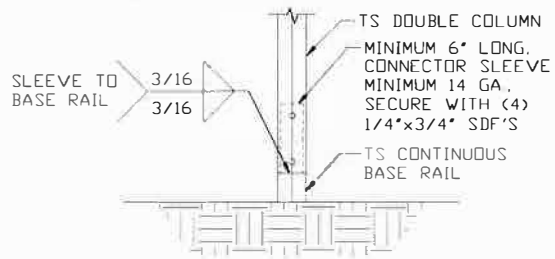
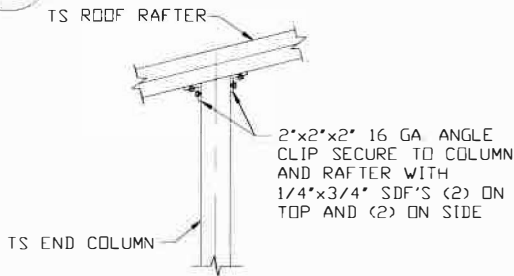

2A RAFTER COLUMN/BASE RAIL CONNECTION DETAIL
SCALE: NTS

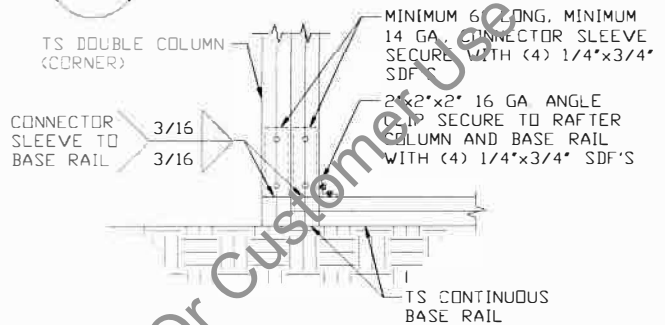

4 END COLUMN/RAFTER CONNECTION DETAIL
SCALE: NTS

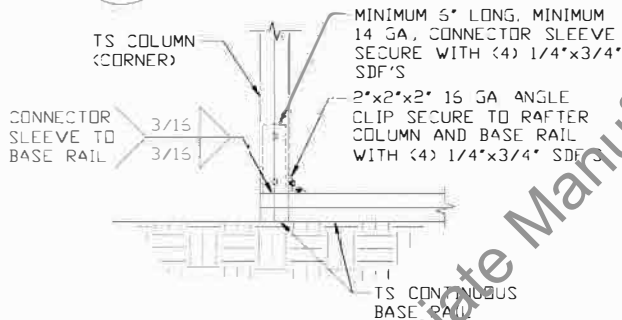

5 END COLUMN/BASE RAIL CONNECTION DETAIL
SCALE: NTS

5A END COLUMN/BASE RAIL CONNECTION DETAIL
SCALE: NTS

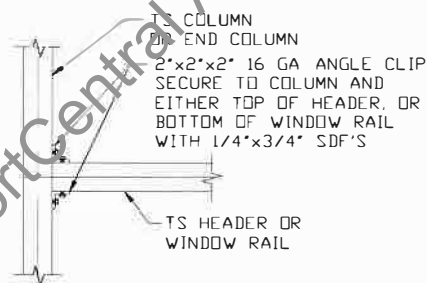

6 COLUMN OR WINDOW RAIL TO POST/TS GIRTS CONNECTION DETAIL
SCALE: NTS

MOORE AND ASSOCIATES ENGINEERING AND CONSULTING, INC.

DRAWN BY: JG
CHECKED BY: PDH

CARPOT CENTRAL, INC.
737 SOUTH MAIN STREET
MOUNT AIRY, NC 27030
30'-0" x 16'-0" ENCLOSED STRUCTURE

THIS DOCUMENT IS THE PROPERTY OF MOORE AND ASSOCIATES ENGINEERING AND CONSULTING. THE UNAUTHORIZED REPRODUCTION, COPYING, OR OTHERWISE USE OF THIS DOCUMENT IS STRICTLY PROHIBITED AND ANY VIOLATION THEREOF MAY BE SUBJECT TO LEGAL ACTION.

PROJECT MGR: WSM	DATE: 6-17-21	SCALE: NTS	JOB NO: 17171S/18253S/20376S/21118S
CLIENT: CC	SHT. 12	DWG. NO: SK-3	REV: 3

CONNECTION DETAILS

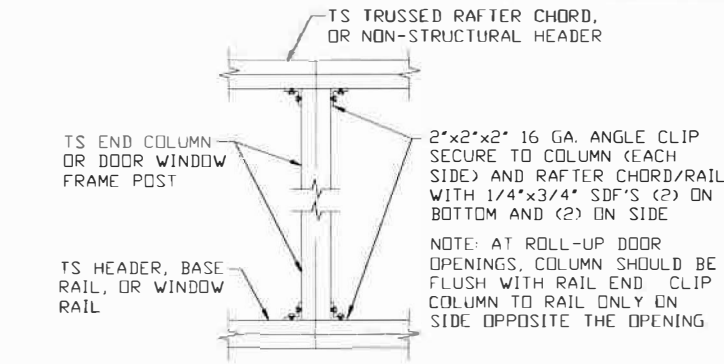

7 COLUMN TO HEADER, BASE RAIL, OR WINDOW RAIL CONNECTION DETAIL
SCALE: NTS

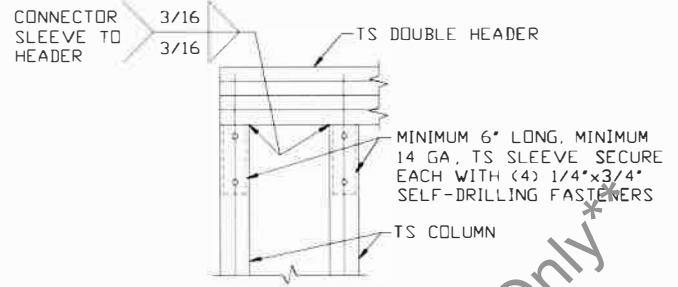

8 DOUBLE HEADER/COLUMN CONNECTION DETAIL
SCALE: NTS

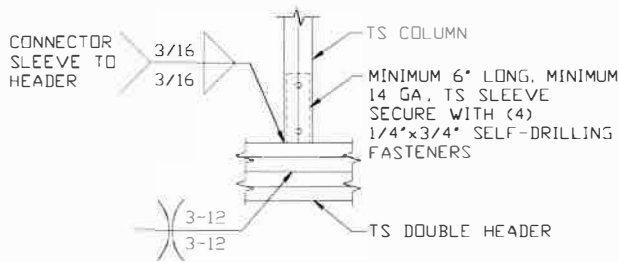

9 COLUMN/DOUBLE HEADER CONNECTION DETAIL
SCALE: NTS

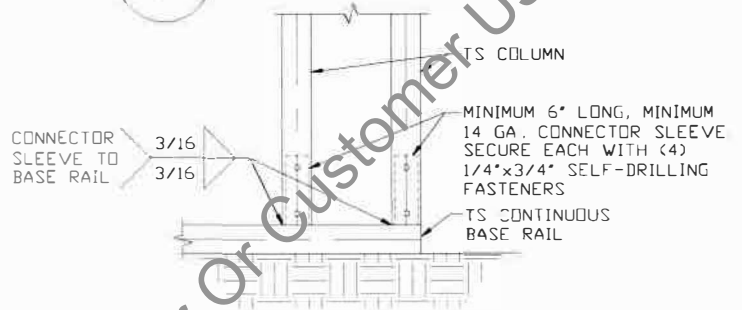

10 COLUMN/BASE RAIL CONNECTION DETAIL
SCALE: NTS

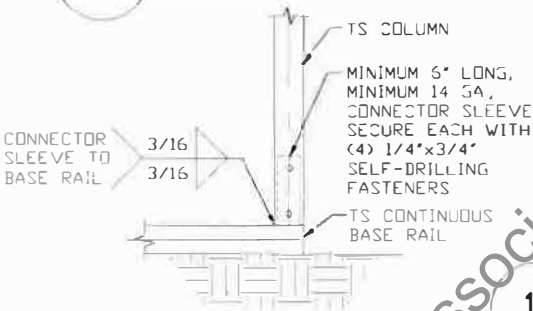

11 RAFTER TO CHORD CONNECTION DETAIL
SCALE: NTS

10A COLUMN/BASE RAIL CONNECTION DETAIL
SCALE: NTS

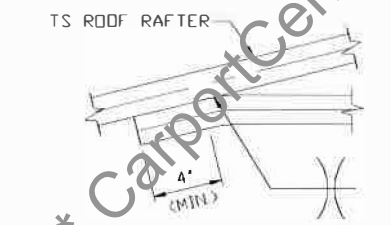

12 COLLAR TIE CONNECTION DETAIL
SCALE: NTS

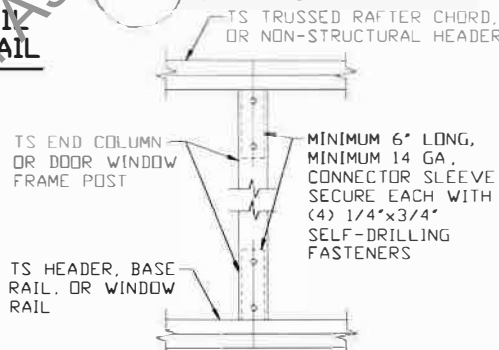

13 COLUMN TO HEADER OR BASE RAIL CONNECTION DETAIL
SCALE: NTS

MOORE AND ASSOCIATES ENGINEERING AND CONSULTING, INC.

DRAWN BY: JG

CHECKED BY: PDH

PROJECT MGR: WSH

CLIENT: CC

CARPORIT CENTRAL, INC.
737 SOUTH MAIN STREET
MOUNT AIRY, NC 27030
30'-0" x 16'-0" ENCLOSED STRUCTURE

DATE: 6-17-21

SHT. 13

SCALE: NTS

DWG. NO: SK-3

JOB NO: 17171S/18253S/
20376S/21118S

REV: 3

THIS DOCUMENT IS THE PROPERTY OF MOORE AND ASSOCIATES ENGINEERING AND CONSULTING, INC. THE UNAUTHORIZED REPRODUCTION, COPYING, OR OTHERWISE USE OF THIS DOCUMENT IS STRICTLY PROHIBITED AND ANY INFRINGEMENT THEREUPON MAY BE SUBJECT TO LEGAL ACTION.

CONNECTION DETAILS

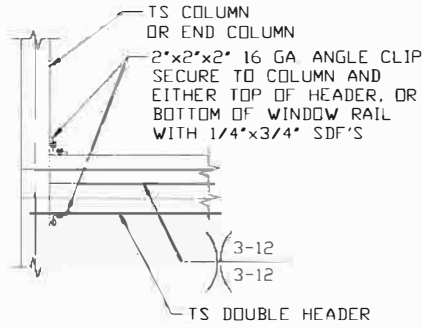

14 COLUMN/DOUBLE HEADER CONNECTION DETAIL
SCALE: NTS

**** CarportCentral Associate Manufacturer Or Customer Use Only****

MOORE AND ASSOCIATES ENGINEERING AND CONSULTING, INC.	DRAWN BY: JG	CARPORT CENTRAL, INC. 737 SOUTH MAIN STREET MOUNT AIRY, NC 27030 30'-0" x 16'-0" ENCLOSED STRUCTURE		
	CHECKED BY: PDH			
THIS DOCUMENT IS THE PROPERTY OF MOORE AND ASSOCIATES ENGINEERING AND CONSULTING. THE UNAUTHORIZED REPRODUCTION, COPYING, OR OTHERWISE USE OF THIS DOCUMENT IS STRICTLY PROHIBITED AND ANY INFRINGEMENT THEREUPON MAY BE SUBJECT TO LEGAL ACTION.	PROJECT MGR: WSM	DATE: 6-17-21	SCALE: NTS	JOB NO: 1717S/18233S/ 20376S/21118S
	CLIENT: CC	SHT. 14	DWG. NO: SK-3	REV: 3

BOX EAVE RAFTER LEAN-TO OPTIONS

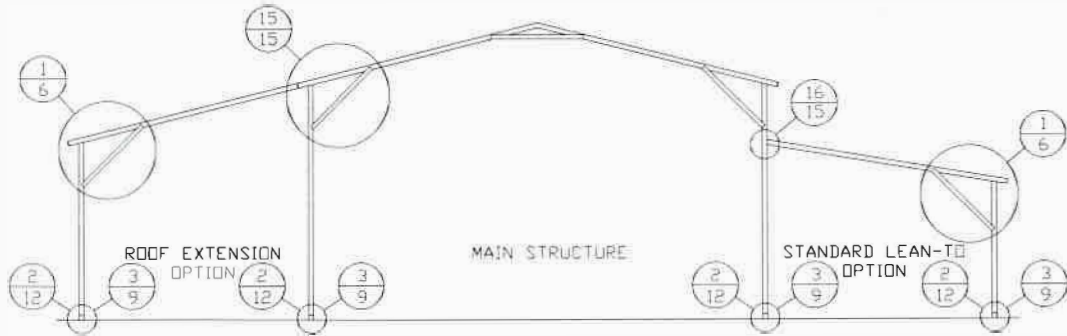

TYPICAL BOX EAVE RAFTER LEAN-TO OPTIONS FRAMING SECTION (BOTH OPTIONS SHOWN)

SCALE: NTS

(MAXIMUM WIDTH OF SINGLE MEMBER ROOF EXTENSION LEAN-TO IS 12'-0")

NOTE: FOR 12'-0" WIDE LEAN-TO KNEE BRACE MUST BE 4'-0".

MAIN BUILDING COLUMNS WITH LEAN-TO OR ROOF EXTENSION ATTACHED ARE REQUIRED TO BE DOUBLE COLUMNS FOR EAVE HEIGHTS 9'-0" < TO ≤ 16'-0".

MAIN BUILDING COLUMNS WITH LEAN-TO OR ROOF EXTENSION ATTACHED ARE REQUIRED TO BE SINGLE COLUMNS FOR EAVE HEIGHTS ≤ 9'-0".

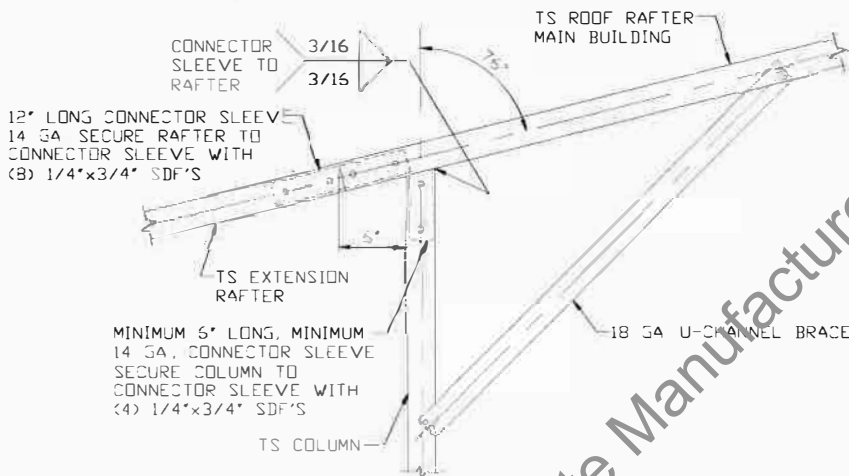

SIDE EXTENSION RAFTER COLUMN DETAIL FOR SPANS ≤ 12'-0"

15

SCALE: NTS

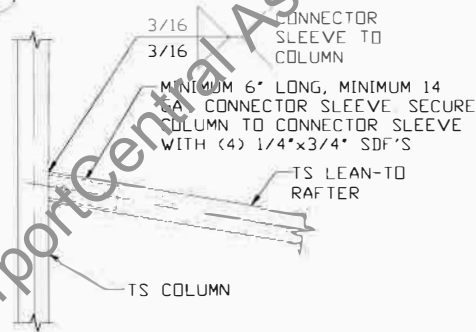

LEAN-TO RAFTER TO RAFTER COLUMN CONNECTION DETAIL FOR RAFTER SPANS ≤ 12'-0"

16

SCALE: NTS

**MOORE AND ASSOCIATES
ENGINEERING AND CONSULTING, INC.**

DRAWN BY: JG

CHECKED BY: PDH

PROJECT MGR: WSM

CLIENT: CC

CARPOR CENTRAL, INC.
737 SOUTH MAIN STREET
MOUNT AIRY, NC 27030
30'-0" x 16'-0" ENCLOSED STRUCTURE

DATE: 6-17-21

SHT. 15

SCALE: NTS

DWG. NO: SK-3

JOB NO: 17171S/18253S/
20376S/21118S

REV: 3

THIS DOCUMENT IS THE PROPERTY OF MOORE AND ASSOCIATES ENGINEERING AND CONSULTING. THE UNAUTHORIZED REPRODUCTION, COPYING, OR OTHERWISE USE OF THIS DOCUMENT IS STRICTLY PROHIBITED AND ANY INFINGEMENT THEREUPON MAY BE SUBJECT TO LEGAL ACTION.

BOW RAFTER LEAN-TO OPTION

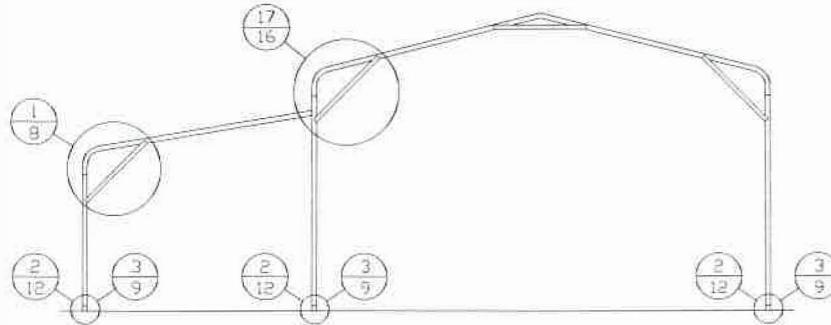

TYPICAL BOW RAFTER LEAN-TO OPTION FRAMING SECTION

SCALE: NTS
 (MAXIMUM WIDTH OF SINGLE MEMBER ROOF EXTENSION LEAN-TO IS 12'-0")
 NOTE: FOR 12'-0" WIDE LEAN-TO KNEE BRACE MUST BE 4'-0"
 MAIN BUILDING COLUMNS WITH LEAN-TO OR ROOF EXTENSION ATTACHED ARE REQUIRED TO BE DOUBLE COLUMNS FOR EAVE HEIGHTS 9'-0" < TO < 16'-0"
 MAIN BUILDING COLUMNS WITH LEAN-TO OR ROOF EXTENSION ATTACHED ARE REQUIRED TO BE SINGLE COLUMNS FOR EAVE HEIGHTS < 9'-0"

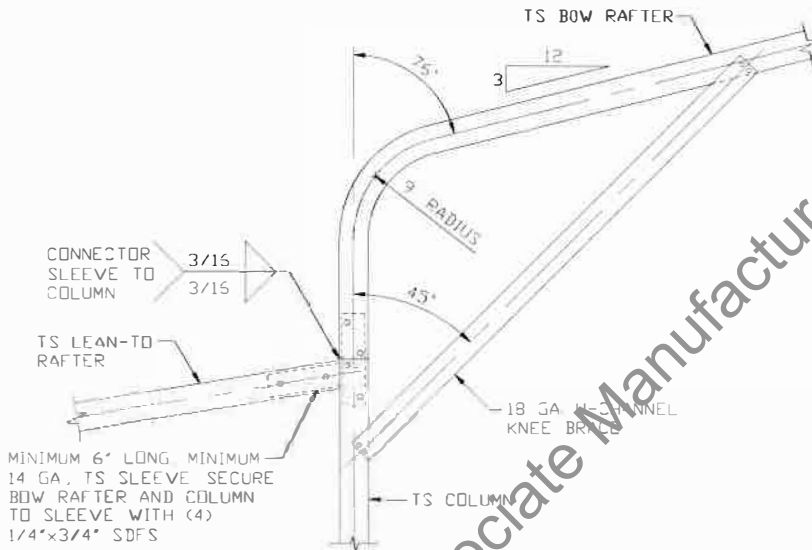

LEAN-TO RAFTER TO RAFTER COLUMN CONNECTION DETAIL FOR RAFTER SPANS ≤ 12'-0"

17
SCALE: NTS

**** CarportCentral Associate Manufacturer Or Customer Use Only****

**MOORE AND ASSOCIATES
ENGINEERING AND CONSULTING, INC.**

DRAWN BY: JG

CHECKED BY: PDH

PROJECT MGR: WSM

CLIENT: CC

CARPORNT CENTRAL, INC.
737 SOUTH MAIN STREET
MOUNT AIRY, NC 27030
30'-0" x 16'-0" ENCLOSED STRUCTURE

DATE: 6-17-21

SHT. 16

SCALE: NTS

DWG. NO SK-3

**JOB NO: 17171S/18253S/
20376S/21118S**

REV: 3

THIS DOCUMENT IS THE PROPERTY OF MOORE AND ASSOCIATES ENGINEERING AND CONSULTING. UNAUTHORIZED REPRODUCTION, COPYING, OR OTHERWISE USE OF THIS DOCUMENT IS STRICTLY PROHIBITED AND ANY OFFENSEMENT THEREOF MAY BE SUBJECT TO LEGAL ACTION.

BOX EAVE RAFTER VERTICAL ROOF OPTION

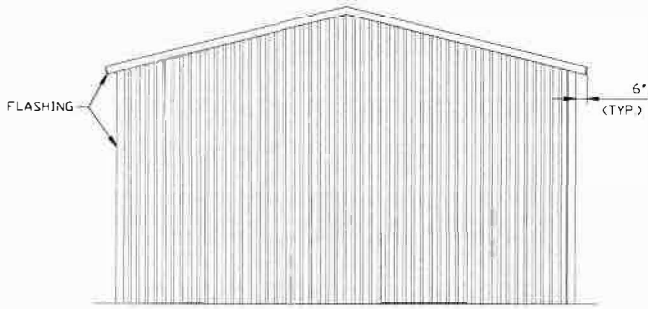

**TYPICAL END ELEVATION
VERTICAL ROOF**
SCALE: NTS

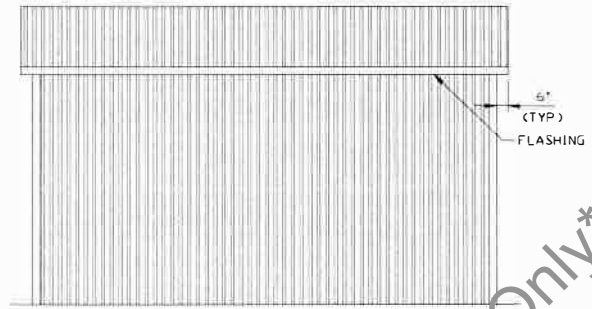

**TYPICAL SIDE ELEVATION
VERTICAL ROOF**
SCALE: NTS

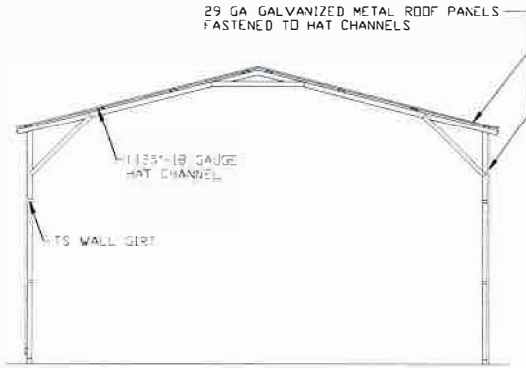

**TYPICAL SECTION
VERTICAL ROOF OPTION**
SCALE: NTS

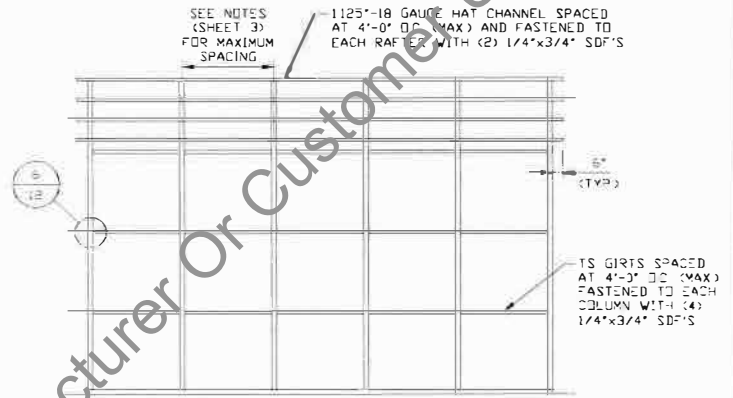

**TYPICAL FRAMING SECTION
VERTICAL ROOF OPTION**
SCALE: NTS
NOTE: HAT CHANNELS CAN BE USED AS AN OPTION IN PLACE OF TS GIRTS. HAT CHANNELS MUST BE SPACED AT 4'-0" OC (MAX)

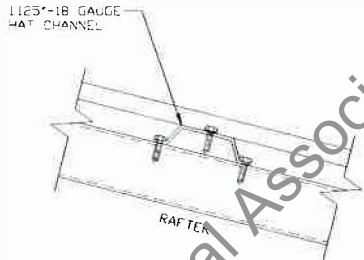

ROOF PANEL ATTACHMENT
(ALTERNATE FOR VERTICAL ROOF PANELS)
SCALE: NTS

**** CarportCentral Associate Manufacturer Or Customer Use Only****

**MOORE AND ASSOCIATES
ENGINEERING AND CONSULTING, INC.**

DRAWN BY: JG

CHECKED BY: PDH

PROJECT MGR: WSM

CLIENT: CC

CARPOT CENTRAL, INC.
737 SOUTH MAIN STREET
MOUNT AIRY, NC 27030
30'-0" x 16'-0" ENCLOSED STRUCTURE

DATE: 6-17-21

SHT. 17

SCALE: NTS

DWG. NO: SK-3

**JOB NO: 17171S/18253S/
20376S/21118S**

REV: 3

THIS DOCUMENT IS THE PROPERTY OF MOORE AND ASSOCIATES ENGINEERING AND CONSULTING. THE UNAUTHORIZED REPRODUCTION, COPYING, OR OTHERWISE USE OF THIS DOCUMENT IS STRICTLY PROHIBITED AND ANY INFRINGEMENT THEREUPON MAY BE SUBJECT TO LEGAL ACTION.

OPTIONAL BASE RAIL ON GRADE APPLICATION

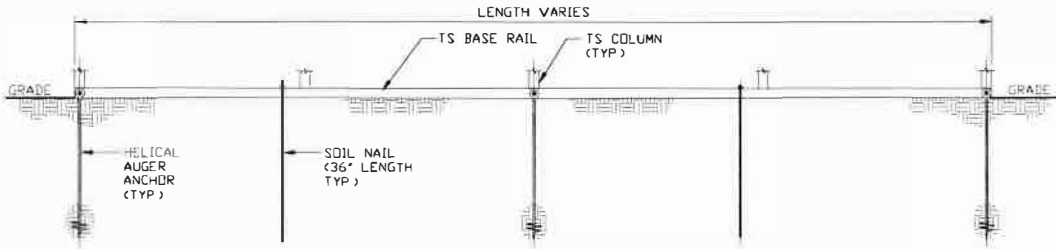

SECTION 2
SCALE: NTS
SK-18



SECTION 1
SCALE: NTS
SK-18

NOTE: SEE DETAIL 3B SHEET 9 FOR HELICAL AUGER ANCHOR DETAIL

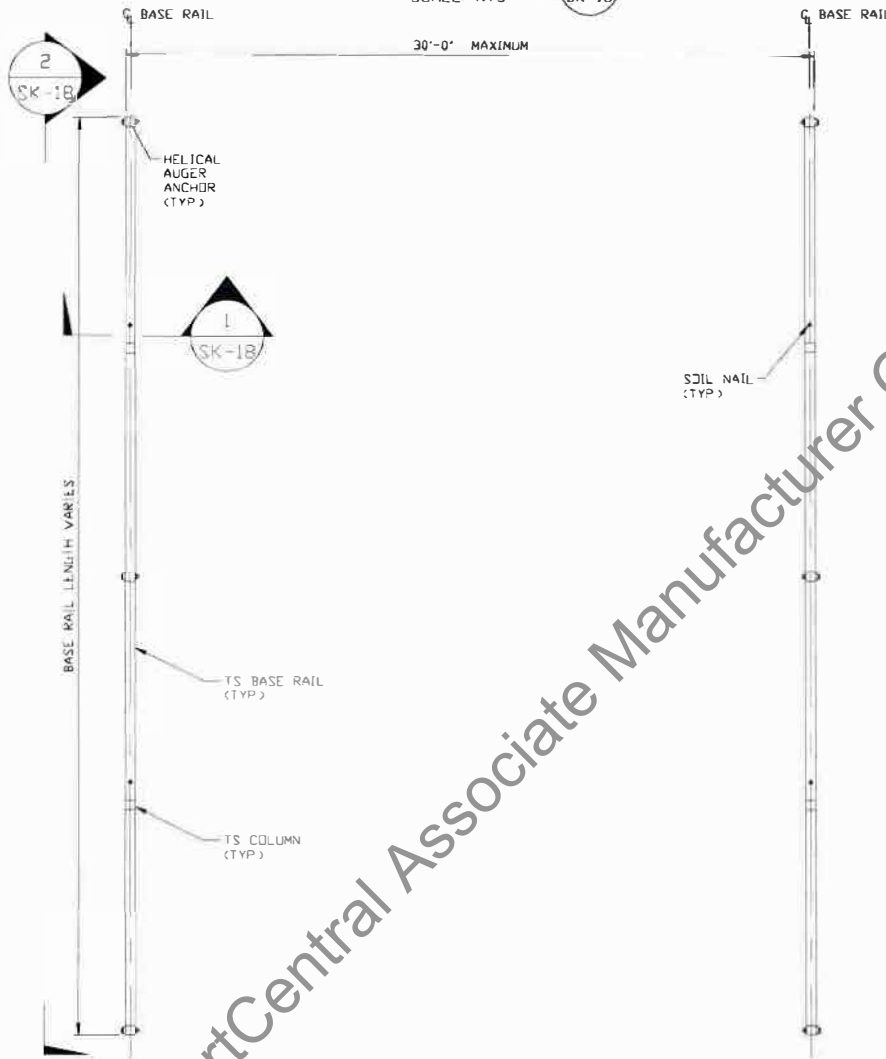

BASE RAIL PLAN
SCALE: NTS

HELIX ANCHOR	
SIZE	SPACING
*LENGTH	
VARIES	10'-0" (AT EVERY OTHER COLUMN)

**MOORE AND ASSOCIATES
ENGINEERING AND CONSULTING, INC.**

DRAWN BY: JG

CHECKED BY: PDH

PROJECT MGR: WSH

CLIENT: CC

CARPORIT CENTRAL, INC.
737 SOUTH MAIN STREET
MOUNT AIRY, NC 27030
30'-0" x 16'-0" ENCLOSED STRUCTURE

DATE: 6-17-21

SHT. 18

SCALE: NTS

DWG. NO: SK-3

JOB NO: 17171S/18253S/
20376S/21118S

REV: 3

THIS DOCUMENT IS THE PROPERTY OF MOORE AND ASSOCIATES ENGINEERING AND CONSULTING. THE UNAUTHORIZED REPRODUCTION, COPYING, OR OTHERWISE USE OF THIS DOCUMENT IS STRICTLY PROHIBITED AND ANY OFFENSEMENT THEREUPON MAY BE SUBJECT TO LEGAL ACTION.

OPTIONAL BASE RAIL ON TIMBER BEAM

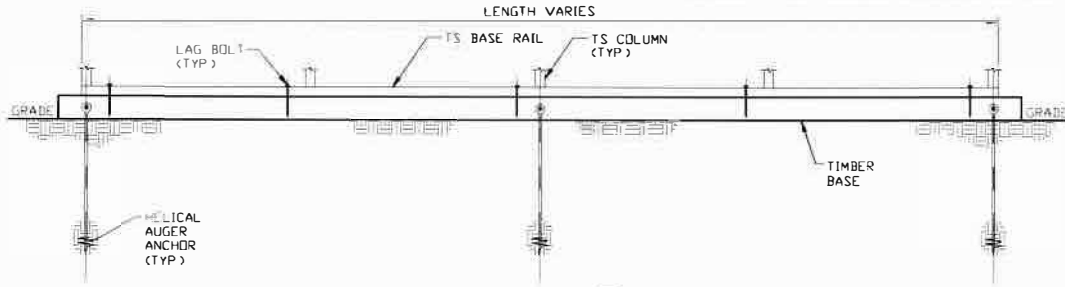

SECTION 2
SCALE: NTS
SK-19

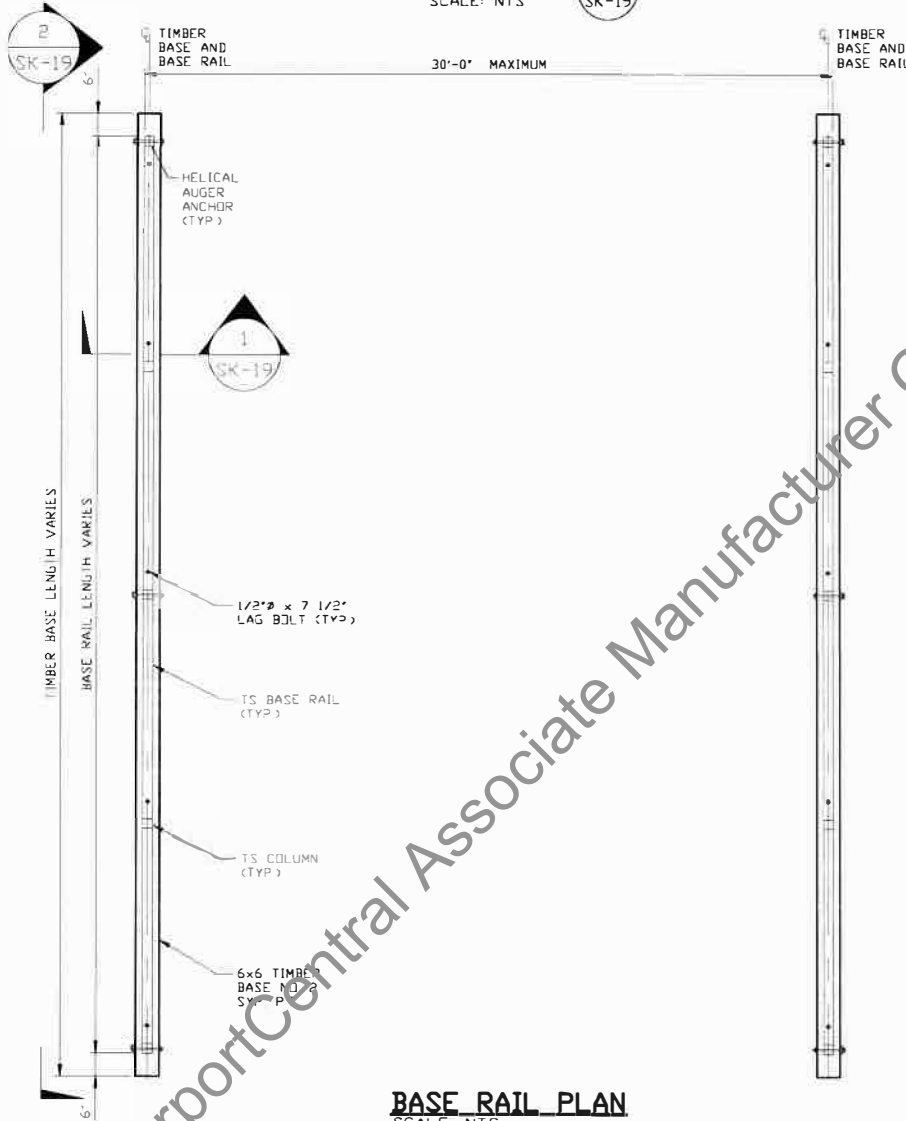

BASE RAIL PLAN
SCALE: NTS

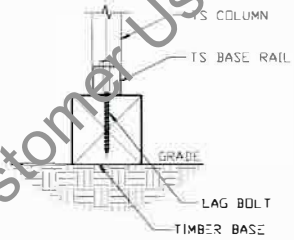

SECTION 1
SCALE: NTS
SK-19

NOTE SEE DETAIL 3B SHEET 9
FOR HELICAL AUGER ANCHOR
DETAIL

** HELIX ANCHOR	
SIDE LENGTH	SPACING
VARIES	10'-0" (AT EVERY OTHER COLUMN)

**MOORE AND ASSOCIATES
ENGINEERING AND CONSULTING, INC.**

DRAWN BY: JG

CHECKED BY: PDH

PROJECT MGR: WSM

CLIENT: CC

CARPORIT CENTRAL, INC.
737 SOUTH MAIN STREET
MOUNT AIRY, NC 27030
30'-0" x 16'-0" ENCLOSED STRUCTURE

DATE: 6-17-21

SHT. 19

SCALE: NTS

DWG. NO SK-3

**JOB NO: 17171S/18253S/
20376S/2111BS**

REV: 3

THIS DOCUMENT IS THE PROPERTY OF MOORE AND ASSOCIATES ENGINEERING AND CONSULTING. THE UNAUTHORIZED REPRODUCTION, COPYING, OR OTHERWISE USE OF THIS DOCUMENT IS STRICTLY PROHIBITED AND ANY INFRINGEMENT THEREUPON MAY BE SUBJECT TO LEGAL ACTION.

OPTIONAL CONCRETE STRIP FOOTING

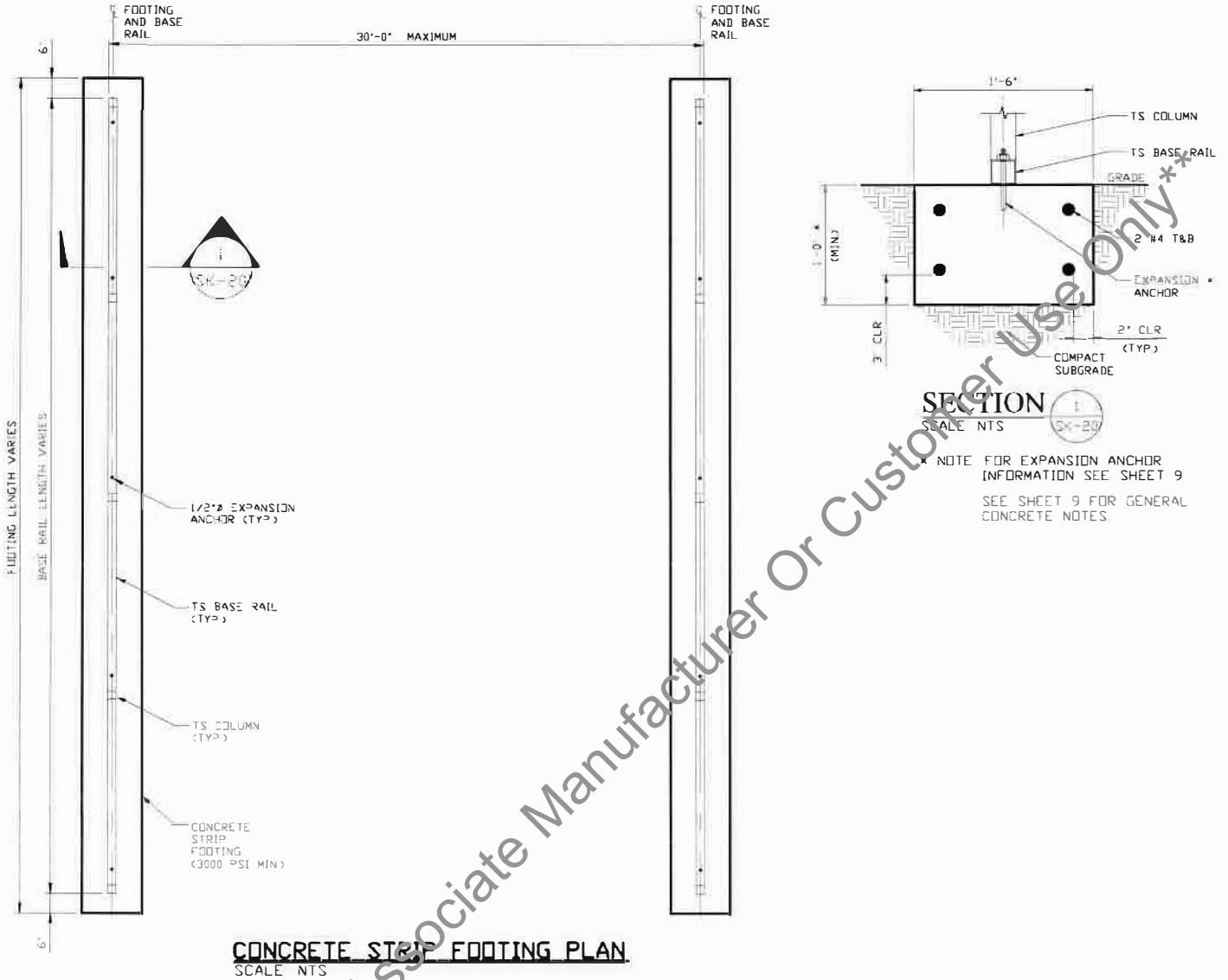

**** CarportCentral Associate Manufacturer Or Customer Use Only ****

MOORE AND ASSOCIATES ENGINEERING AND CONSULTING, INC.	DRAWN BY: JG	CARPORT CENTRAL, INC. 737 SOUTH MAIN STREET MOUNT AIRY, NC 27030 30'-0" x 16'-0" ENCLOSED STRUCTURE		
	CHECKED BY: PDH	PROJECT MGR: WSM	DATE: 6-17-21	SCALE: NTS
CLIENT: CC	SHT. 20	DWG. NO: SK-3	JOB NO: 17171S/18253S/ 20376S/21118S	REV: 3

THIS DOCUMENT IS THE PROPERTY OF MOORE AND ASSOCIATES ENGINEERING AND CONSULTING. THE UNAUTHORIZED REPRODUCTION, COPYING, OR OTHERWISE USE OF THIS DOCUMENT IS STRICTLY PROHIBITED AND ANY INFRINGEMENT THEREUPON MAY BE SUBJECT TO LEGAL ACTION.

SIDE WALL HEADER OPTIONS

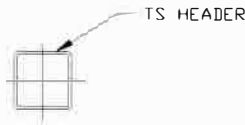

**HEADER DETAIL FOR OPENINGS
≤ 7'-0"**
SCALE: NTS

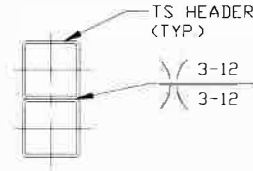

**HEADER DETAIL FOR OPENINGS
7'-0" < LENGTH ≤ 12'-0"**
SCALE: NTS

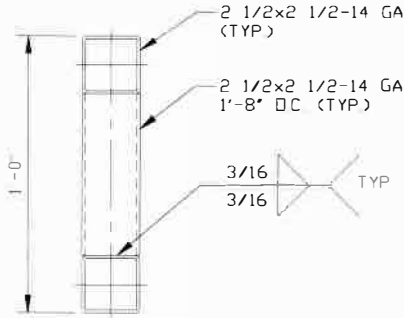

**HEADER DETAIL FOR
OPENINGS 12'-0" < LENGTH ≤ 20'-0"**
SCALE: NTS

END WALL HEADER OPTIONS

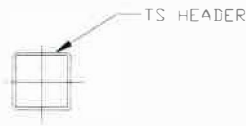

**HEADER DETAIL FOR OPENINGS
≤ 12'-0"**
SCALE: NTS

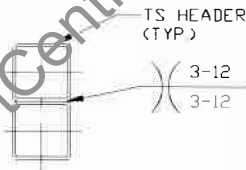

**HEADER DETAIL FOR OPENINGS
12'-0" < LENGTH ≤ 20'-0"**
SCALE: NTS

MOORE AND ASSOCIATES
ENGINEERING AND CONSULTING, INC.

DRAWN BY: JG

CHECKED BY: PDH

PROJECT MGR: WSM

CLIENT: CC

CARPORT CENTRAL, INC.
737 SOUTH MAIN STREET
MOUNT AIRY, NC 27030

30'-0" x 16'-0" ENCLOSED STRUCTURE

DATE: 6-17-21

SHT. 21

SCALE: NTS

DWG. NO: SK-3

JOB NO: 17171S/18253S/
20376S/21118S

REV: 3

THIS DOCUMENT IS THE PROPERTY OF MOORE AND ASSOCIATES ENGINEERING AND CONSULTING, INC. UNAUTHORIZED REPRODUCTION, COPYING, OR OTHERWISE USE OF THIS DOCUMENT IS STRICTLY PROHIBITED AND ANY VIOLATION THEREOF MAY BE SUBJECT TO LEGAL ACTION.