



PILOT MOUNTAIN, NORTH CAROLINA

**STRUCTURAL DESIGN
ENCLOSED BUILDING**

**MAXIMUM 30'-0" WIDE X 16'-0" EAVE HEIGHT- BOX EAVE
FRAME**

2 July 2020

Revision 2

M&A Project No. 18315S/19179S/20176S

Prepared for:

**NC Carports and Garages, LLC
309 S. Depot Street
Pilot Mountain, NC 27041**

Prepared by:

**Moore and Associates Engineering
and Consulting, Inc.**

**1009 East Avenue
North Augusta, SC 29841**

**401 S. Main St., Suite 200
Mt. Airy, NC 27030**



**MOORE AND ASSOCIATES
ENGINEERING AND CONSULTING**



			<p>Professional Certification. I hereby certify that these documents were prepared or approved by me, and that I am a duly licensed professional engineer under the laws of the State of Maryland, License No. 49744, Expiration Date <u>6/6/22</u></p>

MOORE AND ASSOCIATES
ENGINEERING AND CONSULTING, INC.

DRAWN BY: JG
CHECKED BY: PH
PROJECT MGR: WSM
CLIENT: NC CARPORTS

NC CARPORTS AND GARAGES, LLC
309 S. DEPOT STREET
PILOT MOUNTAIN, NC 27041
30'-0" x 16'-0" ENCLOSED STRUCTURE
18315S/19179S/
JOB NO: 20176S
DATE: 7-2-20
SCALE: NTS
SHT. 1
DWG. NO: SK-3
REV: 2

THIS DOCUMENT IS THE PROPERTY OF MOORE AND ASSOCIATES ENGINEERING AND CONSULTING. THE UNAUTHORIZED REPRODUCTION, COPYING, OR OTHERWISE USE OF THIS DOCUMENT IS STRICTLY PROHIBITED AND ANY INFRINGEMENT THEREUPON MAY BE SUBJECT TO LEGAL ACTION.

DRAWING INDEX

SHEET 1	PE SEAL COVER SHEET
SHEET 2	DRAWING INDEX
SHEET 3A	INSTALLATION NOTES AND SPECIFICATIONS
SHEET 3B	TYPICAL SIDE AND END ELEVATIONS
SHEET 3C	TYPICAL SIDE AND END ELEVATIONS
SHEET 4	TYPICAL RAFTER/COLUMN FRAME AND SIDE FRAMING SECTION (BOX EAVE STRUCTURE)
SHEET 4A	TYPICAL RAFTER/COLUMN FRAME AND SIDE FRAMING SECTION (BOX EAVE STRUCTURE)
SHEET 4B	TYPICAL RAFTER/COLUMN FRAME AND SIDE FRAMING SECTION (BOX EAVE STRUCTURE)
SHEET 4C	TYPICAL RAFTER/COLUMN FRAME AND SIDE FRAMING SECTION (BOX EAVE STRUCTURE)
SHEET 5	COLUMN CONNECTION DETAILS (BOX EAVE STRUCTURE)
SHEET 6	COLUMN CONNECTION DETAILS (BOX EAVE STRUCTURE)
SHEET 7	BASE RAIL ANCHORAGE OPTIONS
SHEET 7A	BASE RAIL ANCHORAGE OPTIONS
SHEET 8	TYPICAL END WALL AND SIDE WALL FRAMING SECTIONS
SHEET 8A	TYPICAL END WALL AND SIDE WALL FRAMING SECTIONS
SHEET 9	CONNECTION DETAILS
SHEET 10	CONNECTION DETAILS
SHEET 10A	CONNECTION DETAILS
SHEET 11	LEAN-TO OPTIONS
SHEET 11A	LEAN-TO OPTIONS
SHEET 11B	LEAN-TO OPTIONS
SHEET 12	VERTICAL ROOF/SIDING OPTION END AND SIDE ELEVATION AND SECTION
SHEET 12A	VERTICAL ROOF/SIDING OPTION END AND SIDE ELEVATION AND SECTION

MOORE AND ASSOCIATES ENGINEERING AND CONSULTING, INC.	DRAWN BY: JG	NC CARPORTS AND GARAGES, LLC 309 S. DEPOT STREET PILOT MOUNTAIN, NC 27041 30'-0" x 16'-0" ENCLOSED STRUCTURE		
	CHECKED BY: PH			
THIS DOCUMENT IS THE PROPERTY OF MOORE AND ASSOCIATES ENGINEERING AND CONSULTING. THE UNAUTHORIZED REPRODUCTION, COPYING, OR OTHERWISE USE OF THIS DOCUMENT IS STRICTLY PROHIBITED AND ANY INFRINGEMENT THEREUPON MAY BE SUBJECT TO LEGAL ACTION.	PROJECT MGR: WSM	DATE: 7-2-20	SCALE: NTS	JOB NO: 18315S/19179S/ 20176S
	CLIENT: NC CARPORTS	SHT. 2	DWG. NO: SK-3	REV: 2

INSTALLATION NOTES AND SPECIFICATIONS

1. DESIGN IS FOR MAXIMUM 30'-0" WIDE x 16'-0" EAVE HEIGHT ENCLOSED STRUCTURES.
2. DESIGN WAS DONE IN ACCORDANCE WITH THE 2018 NORTH CAROLINA BUILDING CODE, 2009 INTERNATIONAL BUILDING CODE (IBC), 2012 IBC, 2015 IBC AND 2018 IBC.
3. DESIGN LOADS ARE AS FOLLOWS:
 - A) DEAD LOAD = 1.5 PSF
 - B) LIVE LOAD = 12 PSF
 - C) GROUND SNOW LOAD = 35 PSF
 - = 30 PSF (W ≤ 24'-0" WITH U-CHANNEL COLLAR TIE)

NOTE: UNBALANCED SNOW LOADS DUE TO DRIFTING HAVE NOT BEEN EVALUATED.
4. 3-SECOND GUST ULTIMATE WIND SPEED (V_{ULT}) 105 TO 145 MPH (NOMINAL WIND SPEED 82 TO 112 MPH).
5. MAXIMUM RAFTER/COLUMN AND END COLUMN SPACING = 5.0 FEET (UNLESS NOTED OTHERWISE).
6. SIDEWALL COLUMNS AND ENDWALL COLUMNS ARE SIMILAR IN SIZE, UNLESS NOTED OTHERWISE.
7. RISK CATEGORY I.
8. WIND EXPOSURE CATEGORY B.
9. SPECIFICATIONS APPLICABLE TO 29 GAUGE METAL PANELS FASTENED DIRECTLY TO 2 1/2" x 2 1/2" - 14 GAUGE TUBE STEEL (TS) FRAMING MEMBERS (UNLESS NOTED OTHERWISE).
10. AVERAGE FASTENER SPACING ON-CENTERS ALONG RAFTERS OR HAT CHANNELS, AND COLUMNS (INTERIOR OR END) = 9 INCHES.
11. FASTENERS CONSIST OF #12-14x3/4" SELF-DRILLING FASTENER (SDF), USE CONTROL SEAL WASHER WITH EXTERIOR FASTENERS. SPECIFICATIONS APPLICABLE ONLY FOR MEAN ROOF HEIGHT OF 16 FEET OR LESS, AND ROOF SLOPES OF 14" (3:12 PITCH) OR LESS SPACING REQUIREMENTS FOR OTHER ROOF HEIGHTS AND/OR SLOPES MAY VARY.
12. ANCHORS SHALL BE INSTALLED THROUGH BASE RAIL WITHIN 6" OF EACH COLUMN.
13. STANDARD GROUND ANCHORS (SOIL NAILS) CONSIST OF #4 REBAR W/WELDED NUT 30" LONG. SOIL NAILS MAY BE USED FOR WIND SPEEDS ≤ 145 MPH AND IN SUITABLE SOIL CONDITIONS. OPTIONAL ANCHORAGE MAY BE USED IN SUITABLE SOILS AND MUST BE USED FOR WIND SPEEDS > 145 MPH AND/OR IN SUITABLE SOILS AS NOTED.
14. WIND FORCES GOVERN OVER SEISMIC FORCES. SEISMIC PARAMETERS ANALYZED ARE:
 - SOIL SITE CLASS = D
 - RISK CATEGORY I
 - R = 3.25 $I_E = 1.0$
 - $S_{DS} = 2.039$ $V = C_S W$
 - $S_{D1} = 1.258$

**MOORE AND ASSOCIATES
ENGINEERING AND CONSULTING, INC.**

DRAWN BY: JG

CHECKED BY: PH

PROJECT MGR: WSM

CLIENT: NC CARPORTS

NC CARPORTS AND GARAGES, LLC
309 S. DEPOT STREET
PILOT MOUNTAIN, NC 27041
30'-0" x 16'-0" ENCLOSED STRUCTURE

DATE: 7-2-20

SCALE: NTS

JOB NO: 20176S

SHT. 3A

DWG. NO: SK-3

18315S/19179S/

REV: 2

THIS DOCUMENT IS THE PROPERTY OF MOORE AND ASSOCIATES ENGINEERING AND CONSULTING. THE UNAUTHORIZED REPRODUCTION, COPYING, OR OTHERWISE USE OF THIS DOCUMENT IS STRICTLY PROHIBITED AND ANY INFRINGEMENT THEREUPON MAY BE SUBJECT TO LEGAL ACTION.

BOX EAVE FRAME RAFTER STRUCTURE

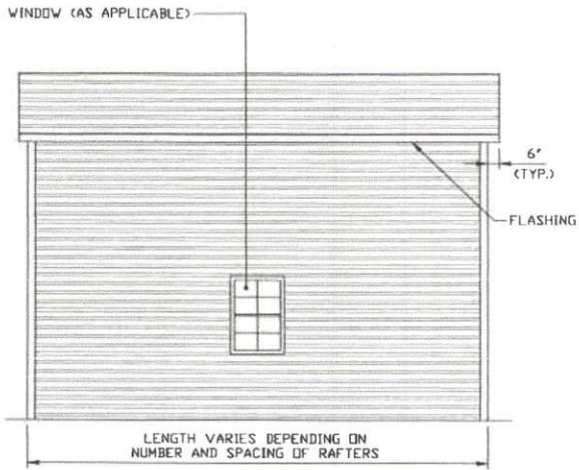

TYPICAL SIDE ELEVATION

SCALE: NTS

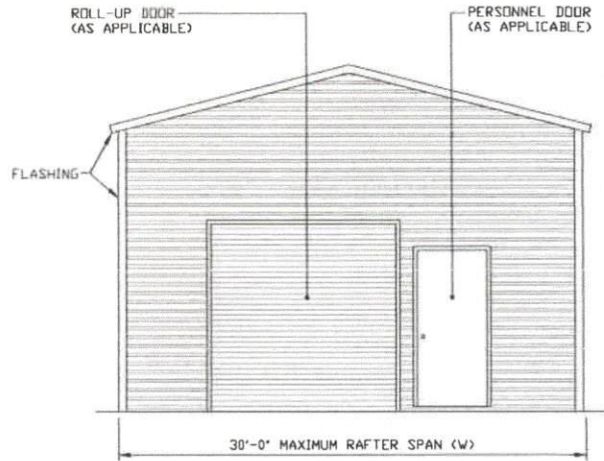

TYPICAL END ELEVATION

SCALE: NTS

**MOORE AND ASSOCIATES
ENGINEERING AND CONSULTING, INC.**

DRAWN BY: JG

CHECKED BY: PH

PROJECT MGR: WSM

CLIENT: NC CARPORTS

NC CARPORTS AND GARAGES, LLC
309 S. DEPOT STREET
PILOT MOUNTAIN, NC 27041
30'-0" x 16'-0" ENCLOSED STRUCTURE

DATE: 7-2-20

SHT. 3B

SCALE: NTS

DWG. NO: SK-3

JOB NO: 20176S
18315S/19179S/

REV: 2

THIS DOCUMENT IS THE PROPERTY OF MOORE AND ASSOCIATES ENGINEERING AND CONSULTING. THE UNAUTHORIZED REPRODUCTION, COPYING, OR OTHERWISE USE OF THIS DOCUMENT IS STRICTLY PROHIBITED AND ANY INFRINGEMENT THEREUPON MAY BE SUBJECT TO LEGAL ACTION.

BOW EAVE FRAME RAFTER STRUCTURE

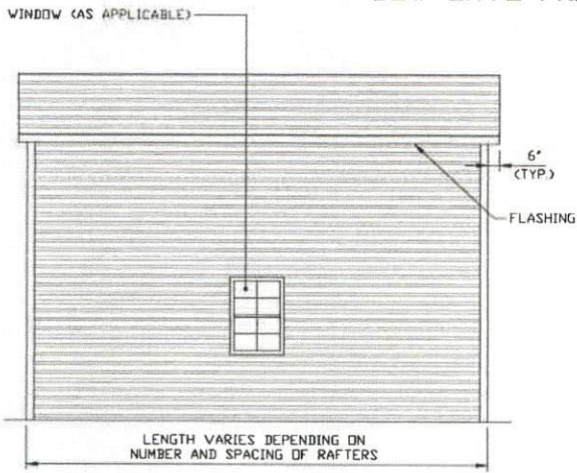

TYPICAL SIDE ELEVATION

SCALE: NTS

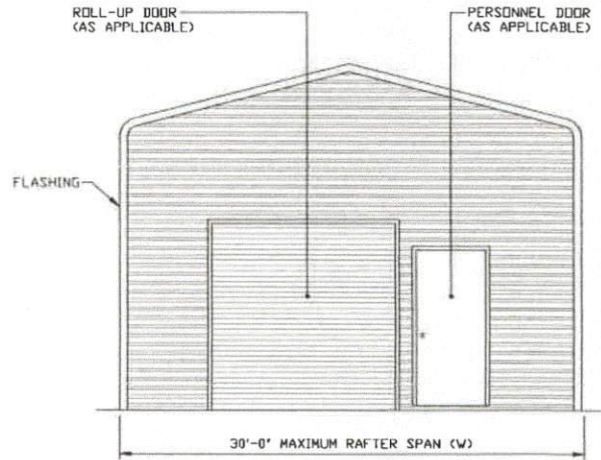

TYPICAL END ELEVATION

SCALE: NTS

**MOORE AND ASSOCIATES
ENGINEERING AND CONSULTING, INC.**

DRAWN BY: JG

CHECKED BY: PH

PROJECT MGR: WSM

CLIENT: NC CARPORTS

NC CARPORTS AND GARAGES, LLC
309 S. DEPOT STREET
PILOT MOUNTAIN, NC 27041
30'-0" x 16'-0" ENCLOSED STRUCTURE

DATE: 7-2-20

SHT. 3C

SCALE: NTS

DWG. NO: SK-3

**18315S/19179S/
JOB NO: 20176S**

REV. 2

THIS DOCUMENT IS THE PROPERTY OF MOORE AND ASSOCIATES ENGINEERING AND CONSULTING. THE UNAUTHORIZED REPRODUCTION, COPYING, OR OTHERWISE USE OF THIS DOCUMENT IS STRICTLY PROHIBITED AND ANY INFRINGEMENT THEREUPON MAY BE SUBJECT TO LEGAL ACTION.

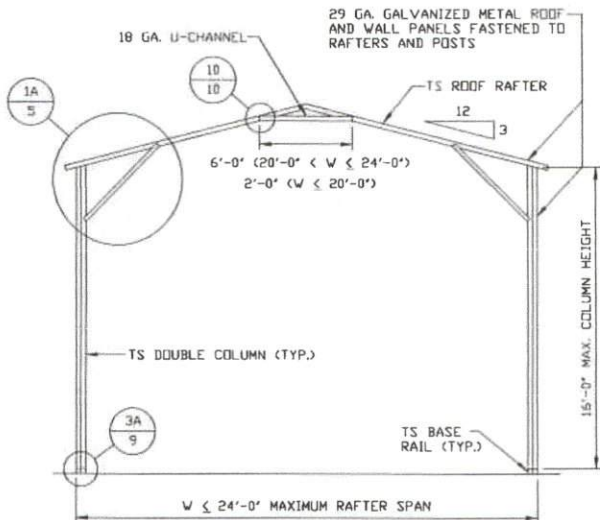

TYPICAL RAFTER/COLUMN FRAME SECTION
SCALE: NTS

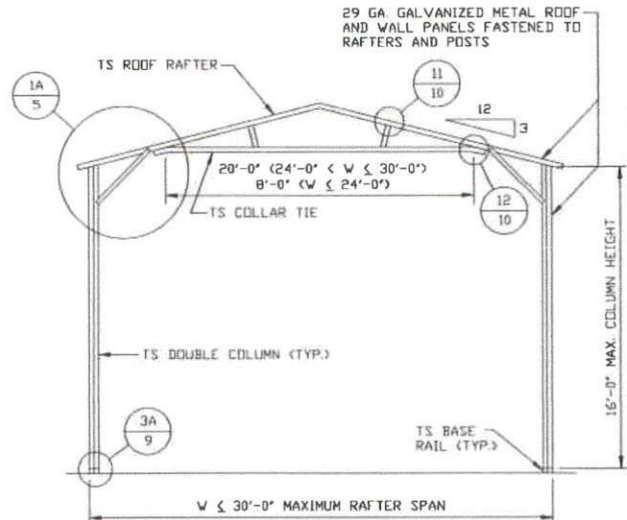

TYPICAL RAFTER/COLUMN FRAME SECTION
SCALE: NTS

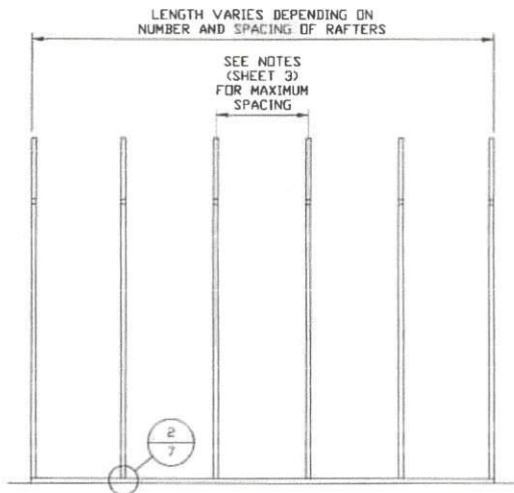

TYPICAL RAFTER/COLUMN SIDE FRAMING SECTION
SCALE: NTS

**MOORE AND ASSOCIATES
ENGINEERING AND CONSULTING, INC.**

DRAWN BY: JG

CHECKED BY: PH

PROJECT MGR: WSM

CLIENT: NC CARPORTS

NC CARPORTS AND GARAGES, LLC
309 S. DEPOT STREET
PILOT MOUNTAIN, NC 27041
30'-0" x 16'-0" ENCLOSED STRUCTURE

DATE: 7-2-20

SHT. 4

SCALE: NTS

DWG. NO: SK-3

18315S/19179S/
JOB NO: 20176S

REV: 2

THIS DOCUMENT IS THE PROPERTY OF MOORE AND ASSOCIATES ENGINEERING AND CONSULTING. THE UNAUTHORIZED REPRODUCTION, COPYING, OR OTHERWISE USE OF THIS DOCUMENT IS STRICTLY PROHIBITED AND ANY INFRINGEMENT THEREUPON MAY BE SUBJECT TO LEGAL ACTION.

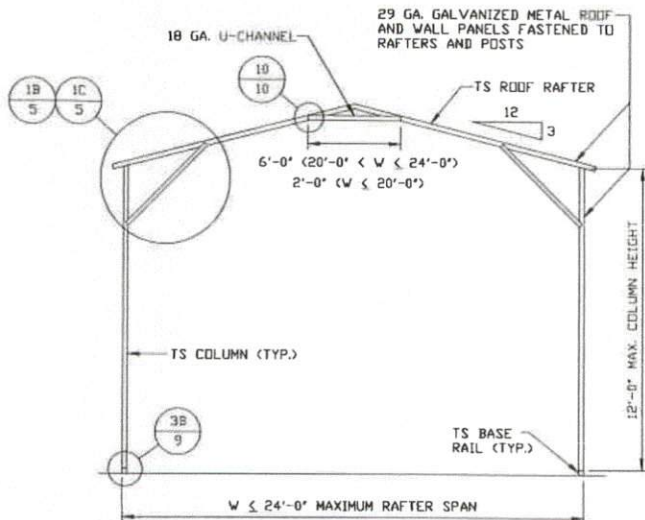

TYPICAL RAFTER/COLUMN FRAME SECTION
SCALE: NTS

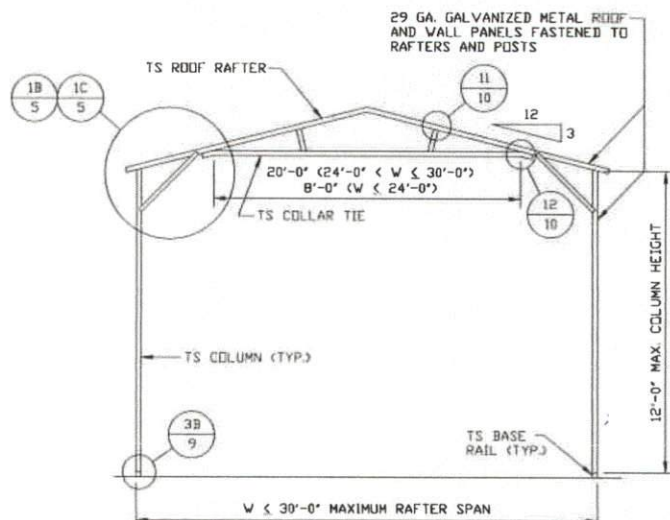

TYPICAL RAFTER/COLUMN FRAME SECTION
SCALE: NTS

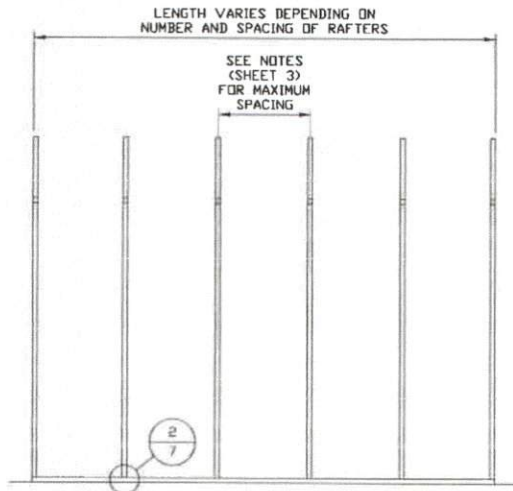

TYPICAL RAFTER/COLUMN SIDE FRAMING SECTION
SCALE: NTS

**MOORE AND ASSOCIATES
ENGINEERING AND CONSULTING, INC.**

DRAWN BY: JG

CHECKED BY: PH

PROJECT MGR: WSM

CLIENT: NC CARPORTS

NC CARPORTS AND GARAGES, LLC
309 S. DEPOT STREET
PILOT MOUNTAIN, NC 27041
30'-0" x 16'-0" ENCLOSED STRUCTURE

DATE: 7-2-20

SHT. 4A

SCALE: NTS

DWG. NO: SK-3

10315S/19179S/
JOB NO: 20176S

REV: 2

THIS DOCUMENT IS THE PROPERTY OF MOORE AND ASSOCIATES ENGINEERING AND CONSULTING. THE UNAUTHORIZED REPRODUCTION, COPYING, OR OTHERWISE USE OF THIS DOCUMENT IS STRICTLY PROHIBITED AND ANY INFRINGEMENT THEREUPON MAY BE SUBJECT TO LEGAL ACTION.

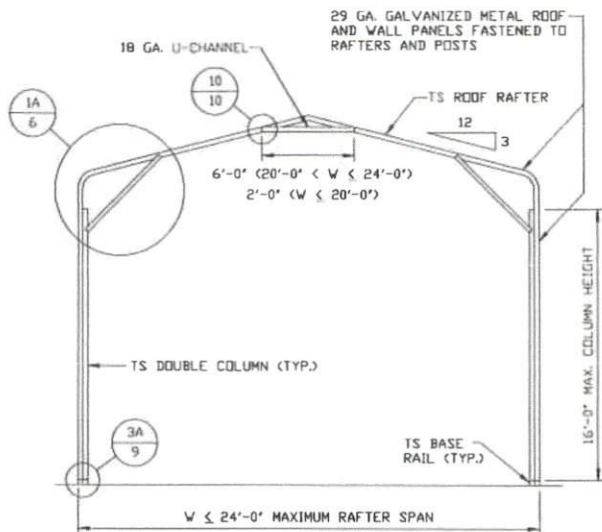

TYPICAL RAFTER/COLUMN FRAME SECTION
SCALE: NTS

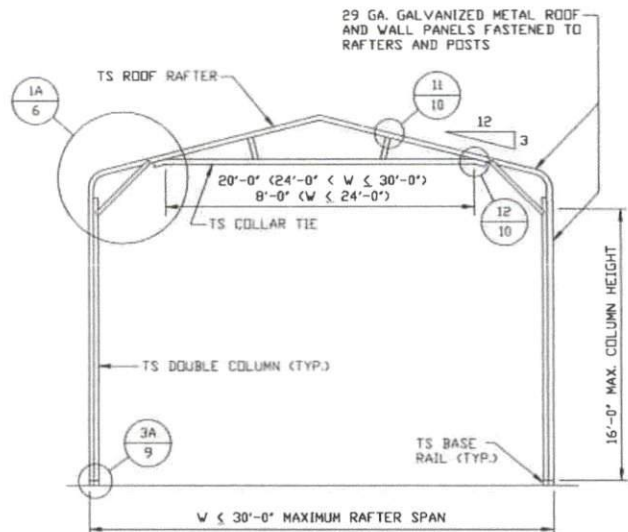

TYPICAL RAFTER/COLUMN FRAME SECTION
SCALE: NTS

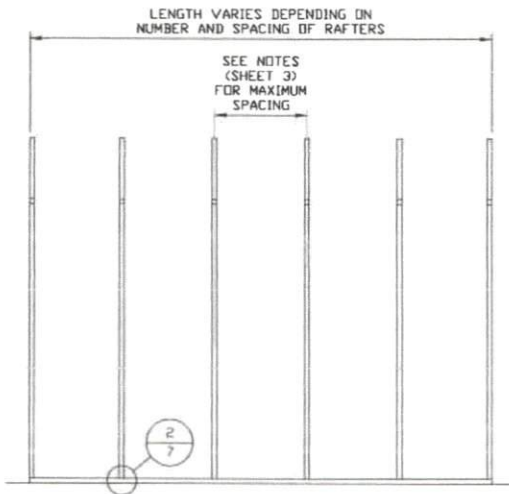

TYPICAL RAFTER/COLUMN SIDE FRAMING SECTION
SCALE: NTS

**MOORE AND ASSOCIATES
ENGINEERING AND CONSULTING, INC.**

DRAWN BY: JG

CHECKED BY: PH

PROJECT MGR: WSM

CLIENT: NC CARPORTS

NC CARPORTS AND GARAGES, LLC
309 S. DEPOT STREET
PILOT MOUNTAIN, NC 27041
30'-0" x 16'-0" ENCLOSED STRUCTURE

DATE: 7-2-20

SHT. 4B

SCALE: NTS

DWG. NO: SK-3

18315S/19179S/
JOB NO: 20176S

REV: 2

THIS DOCUMENT IS THE PROPERTY OF MOORE AND ASSOCIATES ENGINEERING AND CONSULTING. THE UNAUTHORIZED REPRODUCTION, COPYING, OR OTHERWISE USE OF THIS DOCUMENT IS STRICTLY PROHIBITED AND ANY INFRINGEMENT THEREUPON MAY BE SUBJECT TO LEGAL ACTION.

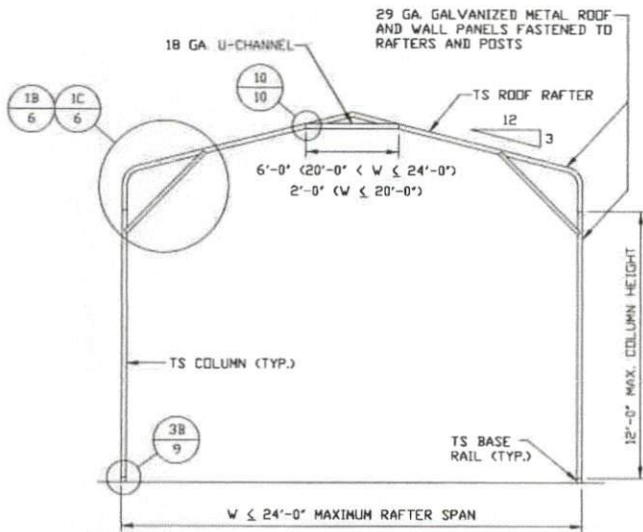

TYPICAL RAFTER/COLUMN FRAME SECTION
SCALE: NTS

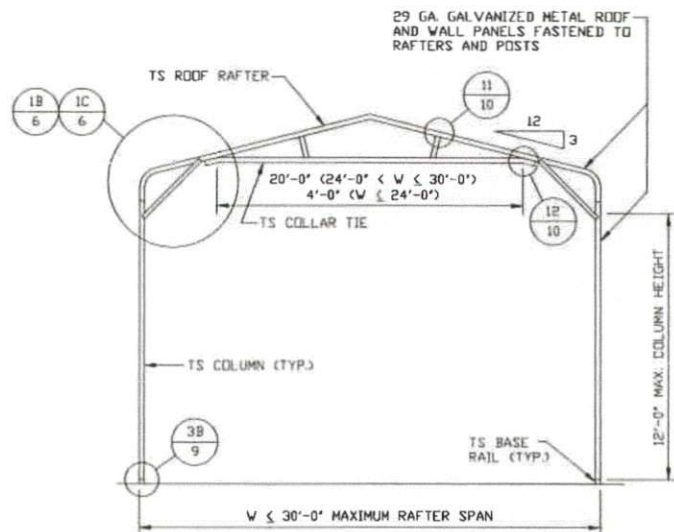

TYPICAL RAFTER/COLUMN FRAME SECTION
SCALE: NTS

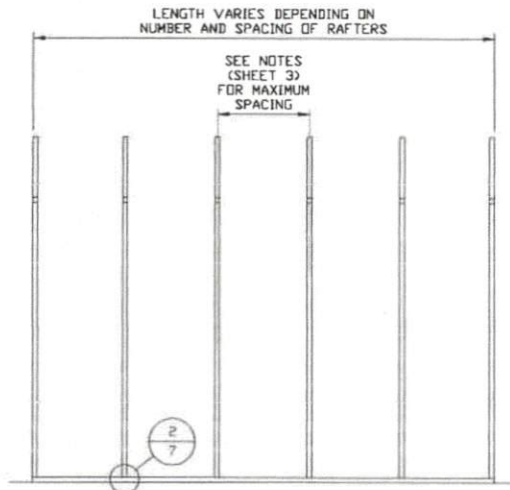

TYPICAL RAFTER/COLUMN SIDE FRAMING SECTION
SCALE: NTS

MOORE AND ASSOCIATES
ENGINEERING AND CONSULTING, INC.

DRAWN BY: JG

CHECKED BY: PH

PROJECT MGR: WSM

CLIENT: NC CARPORTS

NC CARPORTS AND GARAGES, LLC
309 S. DEPOT STREET
PILOT MOUNTAIN, NC 27041
30'-0" x 16'-0" ENCLOSED STRUCTURE

DATE: 7-2-20

SHT. 4C

SCALE: NTS

DWG. NO: SK-3

1831SS/19179S/
JOB NO: 20176S

REV: 2

THIS DOCUMENT IS THE PROPERTY OF MOORE AND ASSOCIATES ENGINEERING AND CONSULTING. THE UNAUTHORIZED REPRODUCTION, COPYING, OR OTHERWISE USE OF THIS DOCUMENT IS STRICTLY PROHIBITED AND ANY INFRINGEMENT THEREUPON MAY BE SUBJECT TO LEGAL ACTION.

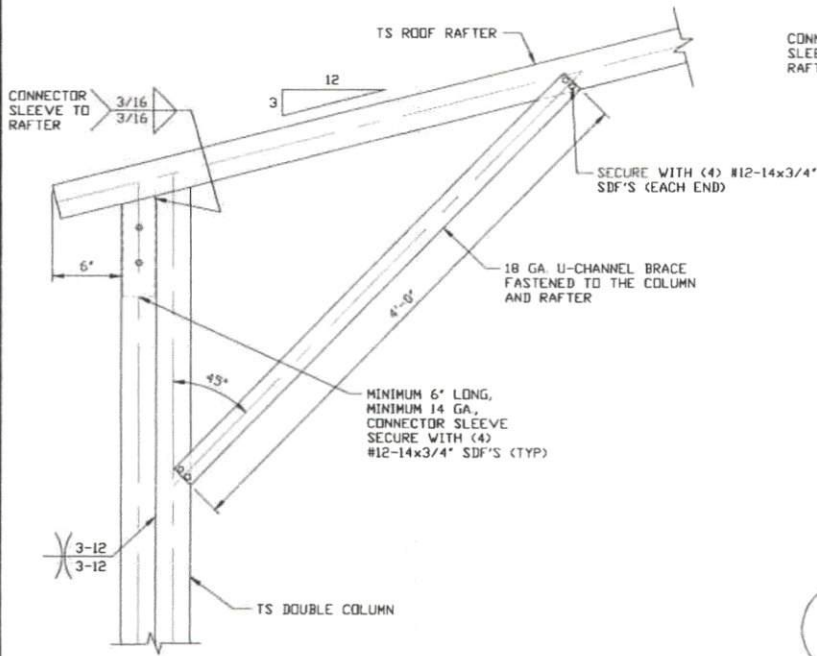

1A

BOX EAVE RAFTER/CORNER POST CONNECTION DETAIL FOR HEIGHTS 12'-0" < TO ≤ 16'-0"
SCALE: NTS

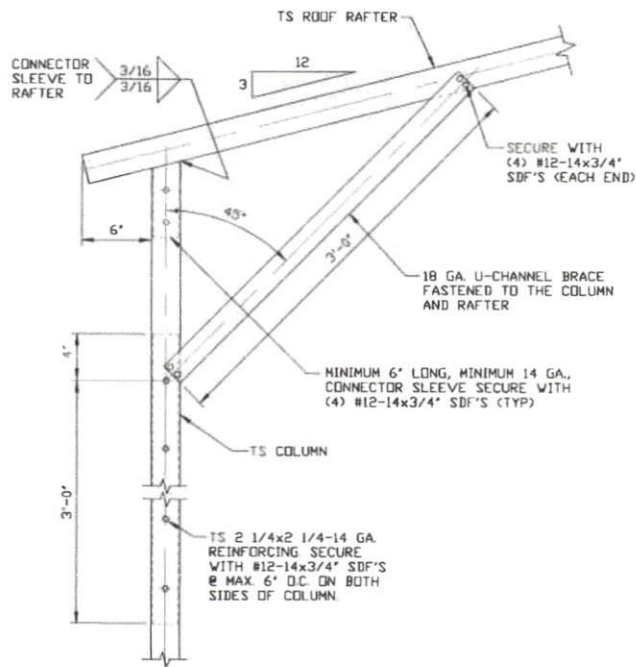

1B

BOX EAVE RAFTER/CORNER POST CONNECTION DETAIL FOR HEIGHTS 10'-0" < TO ≤ 12'-0"
SCALE: NTS

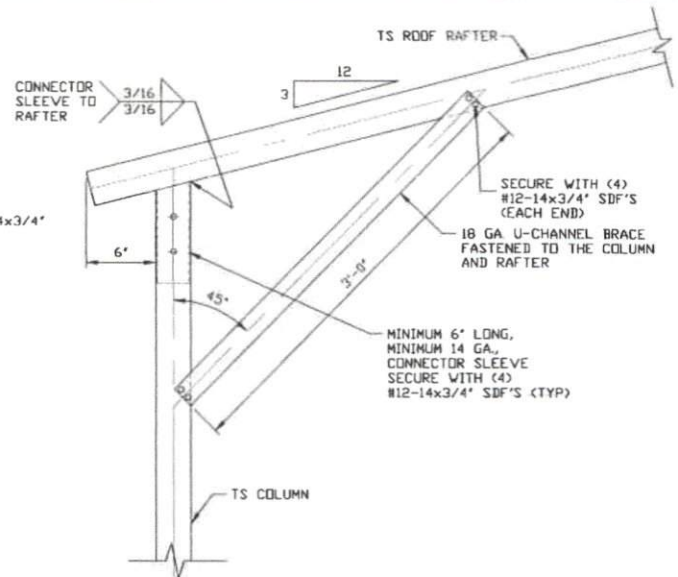

1C

BOX EAVE RAFTER/CORNER POST CONNECTION DETAIL FOR HEIGHTS ≤ 10'-0"
SCALE: NTS

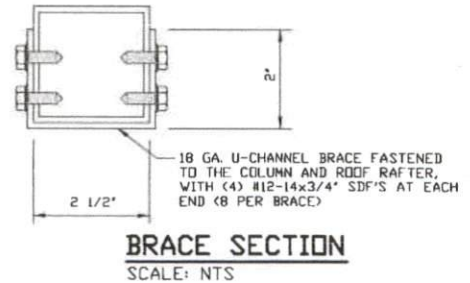

BRACE SECTION
SCALE: NTS

MOORE AND ASSOCIATES ENGINEERING AND CONSULTING, INC.

DRAWN BY: JG

CHECKED BY: PH

PROJECT MGR: WSM

CLIENT: NC CARPORTS

NC CARPORTS AND GARAGES, LLC
309 S. DEPOT STREET
PILOT MOUNTAIN, NC 27041
30'-0" x 16'-0" ENCLOSED STRUCTURE

DATE: 7-2-20

SCALE: NTS

19315S/19179S/
JOB NO: 20176S

SHT. 5

DWG. NO: SK-3

REV: 2

THIS DOCUMENT IS THE PROPERTY OF MOORE AND ASSOCIATES ENGINEERING AND CONSULTING. THE UNAUTHORIZED REPRODUCTION, COPYING, OR OTHERWISE USE OF THIS DOCUMENT IS STRICTLY PROHIBITED AND ANY INFRINGEMENT THEREUPON MAY BE SUBJECT TO LEGAL ACTION.

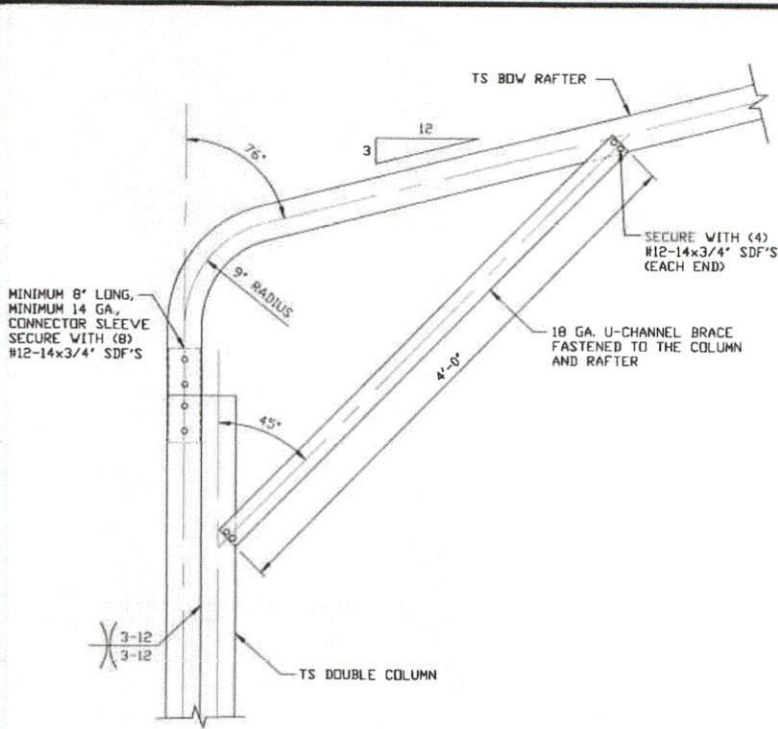

1A BOX EAVE RAFTER/CORNER POST CONNECTION DETAIL FOR HEIGHTS 12'-0" < TO ≤ 16'-0" SCALE: NTS

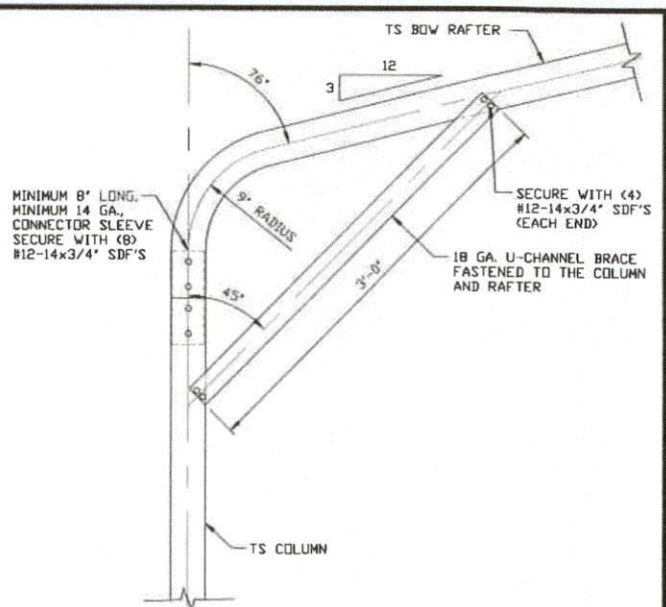

1C BOX EAVE RAFTER/CORNER POST CONNECTION DETAIL FOR HEIGHTS ≤ 10'-0" SCALE: NTS

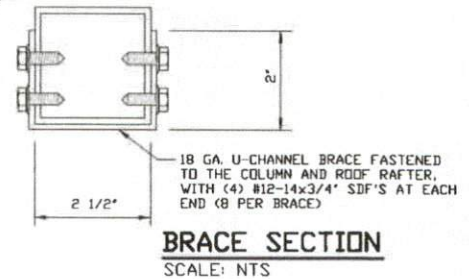

BRACE SECTION SCALE: NTS

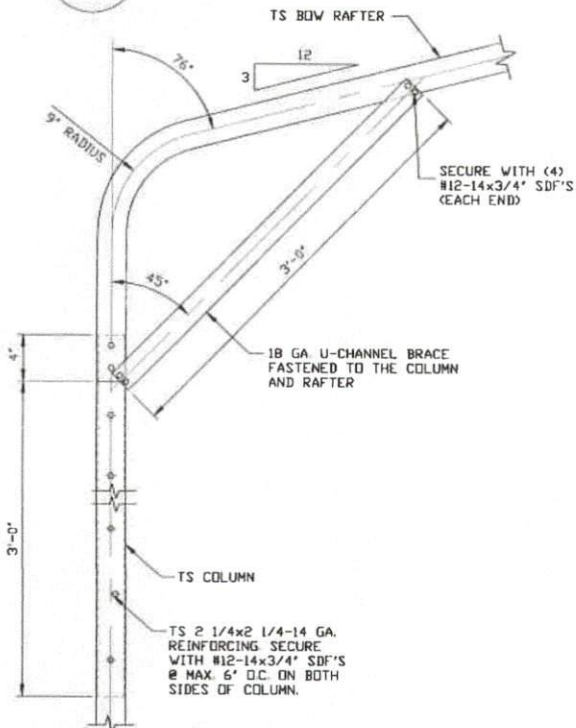

1B BOW RAFTER/CORNER POST CONNECTION DETAIL FOR HEIGHTS 10'-0" < TO ≤ 12'-0" SCALE: NTS

MOORE AND ASSOCIATES
ENGINEERING AND CONSULTING, INC.

DRAWN BY: JG

CHECKED BY: PH

PROJECT MGR: WSM

CLIENT: NC CARPORTS

NC CARPORTS AND GARAGES, LLC
309 S. DEPOT STREET
PILOT MOUNTAIN, NC 27041
30'-0" x 16'-0" ENCLOSED STRUCTURE

DATE: 7-2-20

SHT. 6

SCALE: NTS

DWG. NO: SK-3

18315S/19179S/
JOB NO: 20176S

REV: 2

THIS DOCUMENT IS THE PROPERTY OF MOORE AND ASSOCIATES ENGINEERING AND CONSULTING. THE UNAUTHORIZED REPRODUCTION, COPYING, OR OTHERWISE USE OF THIS DOCUMENT IS STRICTLY PROHIBITED AND ANY INFRINGEMENT THEREUPON MAY BE SUBJECT TO LEGAL ACTION.

BASE RAIL ANCHORAGE OPTIONS

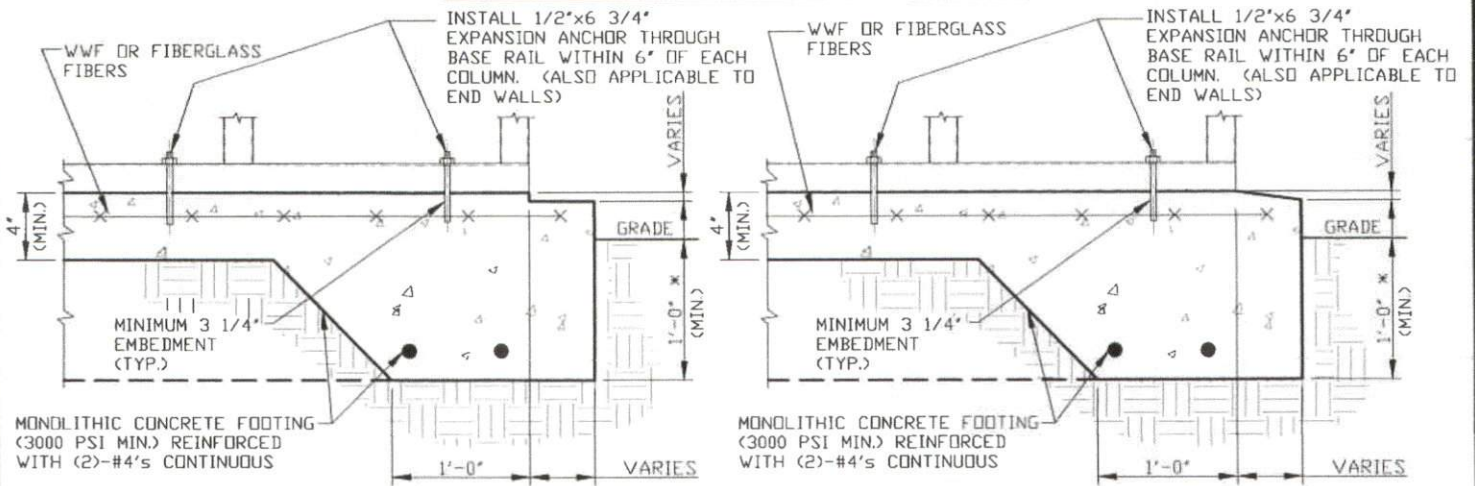

2A CONCRETE MONOLITHIC SLAB BASE RAIL ANCHORAGE
 SCALE: NTS
 MINIMUM ANCHOR EDGE DISTANCE IS 4".
 * COORDINATE WITH LOCAL BUILDING CODE AND/OR D REGARDING MINIMUM FROST DEPTH (LENGTH).

2B CONCRETE MONOLITHIC SLAB BASE RAIL ANCHORAGE
 SCALE: NTS
 MINIMUM ANCHOR EDGE DISTANCE IS 4".
 * COORDINATE WITH LOCAL BUILDING CODE AND/OR D REGARDING MINIMUM FROST DEPTH (LENGTH).

GENERAL NOTES

NOTE: CONCRETE MONOLITHIC SLAB DESIGN BASED ON MINIMUM SOIL BEARING CAPACITY OF 1,500 PSF.

CONCRETE:

CONCRETE SHALL HAVE A MINIMUM SPECIFIED COMPRESSIVE STRENGTH OF 3,000 PSI AT 28 DAYS.

COVER OVER REINFORCING STEEL:

FOR FOUNDATIONS, MINIMUM CONCRETE COVER OVER REINFORCING BARS SHALL BE PER ACI-318:
 3" IN FOUNDATIONS WHERE THE CONCRETE IS CAST AGAINST AND PERMANENTLY IN CONTACT WITH THE EARTH OR EXPOSED TO THE EARTH OR WEATHER, AND 1 1/2" ELSEWHERE.

REINFORCING STEEL:

THE TURNDOWN REINFORCING STEEL SHALL BE ASTM A615 GRADE 60. THE SLAB REINFORCEMENT SHALL BE WELDED WIRE FABRIC MEETING ASTM A185 OR FIBERGLASS FIBER REINFORCEMENT.

REINFORCEMENT MAY BE BENT IN THE SHOP OR THE FIELD PROVIDED:

1. REINFORCEMENT IS BENT COLD.
2. THE DIAMETER OF THE BEND, MEASURED ON THE INSIDE OF THE BAR, IS NOT LESS THAN SIX-BAR DIAMETERS.
3. REINFORCEMENT PARTIALLY EMBEDDED IN CONCRETE SHALL NOT BE FIELD BENT.

HELIX ANCHOR NOTES:

1. FOR VERY DENSE AND/OR CEMENTED SANDS, COARSE GRAVEL AND COBBLES, CALICHE, PRELOADED SILTS AND CLAYS, USE MINIMUM (2) 4" HELICES WITH MINIMUM 30" EMBEDMENT OR SINGLE 6" HELIX WITH MINIMUM 50" EMBEDMENT
2. FOR CORAL USE MINIMUM (2) 4" HELICES WITH MINIMUM 30" EMBEDMENT OR SINGLE 6" HELIX WITH MINIMUM 50" EMBEDMENT.
3. FOR MEDIUM DENSE COARSE SANDS, SANDY GRAVELS, VERY STIFF SILTS, AND CLAYS USE MINIMUM (2) 4" HELICES WITH MINIMUM 30 INCH EMBEDMENT OR SINGLE 6" HELIX WITH MINIMUM 50" EMBEDMENT.
4. FOR LOOSE TO MEDIUM DENSE SANDS, FIRM TO STIFF CLAYS AND SILTS ALLUVIAL FILL, USE MINIMUM (2) 6" HELICES WITH MINIMUM 50" EMBEDMENT.
5. FOR VERY LOSE TO MEDIUM DENSE SANDS, FIRM TO STIFFER CLAYS AND SILTS, ALLUVIAL FILL, USE MINIMUM (2) 8" HELICES WITH MINIMUM 60" EMBEDMENT.

**MOORE AND ASSOCIATES
 ENGINEERING AND CONSULTING, INC.**

DRAWN BY: JG
CHECKED BY: PH

NC CARPORTS AND GARAGES, LLC
 309 S. DEPOT STREET
 PILOT MOUNTAIN, NC 27041
 30'-0" x 16'-0" ENCLOSED STRUCTURE

PROJECT MGR: WSM	DATE: 7-2-20	SCALE: NTS	JOB NO: 20176S 18315S/19179S/
CLIENT: NC CARPORTS	SHT. 7	DWG. NO: SK-3	REV: 2

THIS DOCUMENT IS THE PROPERTY OF MOORE AND ASSOCIATES ENGINEERING AND CONSULTING. THE UNAUTHORIZED REPRODUCTION, COPYING, OR OTHERWISE USE OF THIS DOCUMENT IS STRICTLY PROHIBITED AND ANY INFRINGEMENT THEREUPON MAY BE SUBJECT TO LEGAL ACTION.

BASE RAIL ANCHORAGE OPTIONS

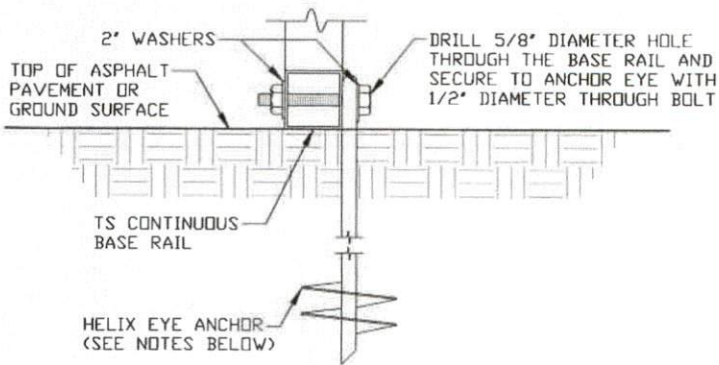

2C

GROUND BASE HELIX ANCHORAGE

SCALE: NTS
(CAN BE USED FOR ASPHALT)

* COORDINATE WITH LOCAL BUILDING CODE AND/OR D REGARDING MINIMUM FROST DEPTH (LENGTH).

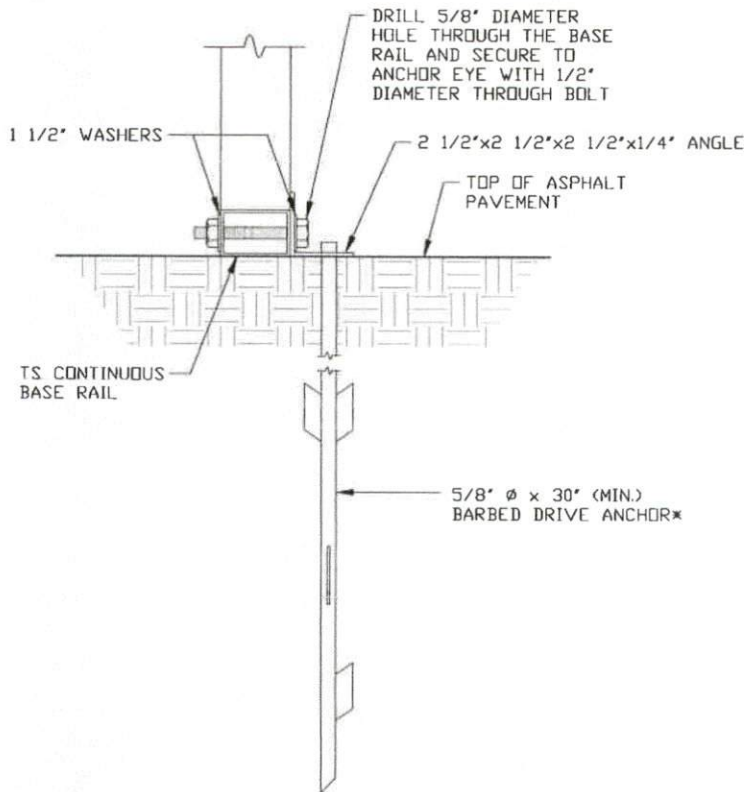

2D

ASPHALT BASE ANCHORAGE

SCALE: NTS

* COORDINATE WITH LOCAL BUILDING CODE AND/OR D REGARDING MINIMUM FROST DEPTH (LENGTH).

MOORE AND ASSOCIATES
ENGINEERING AND CONSULTING, INC.

DRAWN BY: JG

CHECKED BY: PH

PROJECT MGR: WSM

CLIENT: NC CARPORTS

NC CARPORTS AND GARAGES, LLC
309 S. DEPOT STREET
PILOT MOUNTAIN, NC 27041
30'-0" x 16'-0" ENCLOSED STRUCTURE

DATE: 7-2-20

SHT. 7A

SCALE: NTS

DWG. NO: SK-3

19315S/19179S/
JOB NO: 20176S

REV: 2

THIS DOCUMENT IS THE PROPERTY OF MOORE AND ASSOCIATES ENGINEERING AND CONSULTING. THE UNAUTHORIZED REPRODUCTION, COPYING, OR OTHERWISE USE OF THIS DOCUMENT IS STRICTLY PROHIBITED AND ANY INFRINGEMENT THEREUPON MAY BE SUBJECT TO LEGAL ACTION.

BOX EAVE RAFTER END WALL AND SIDE WALL OPENINGS

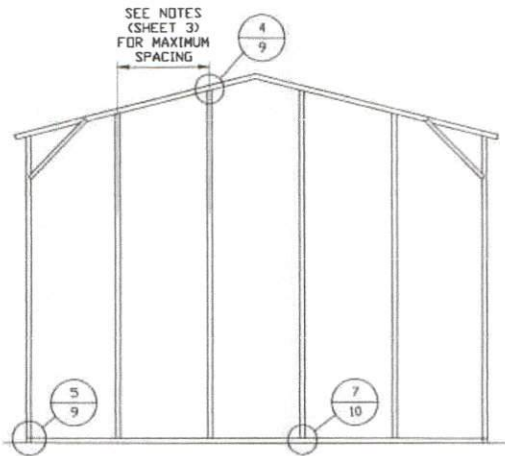

**TYPICAL BOX EAVE RAFTER
END WALL FRAMING SECTION**

SCALE: NTS

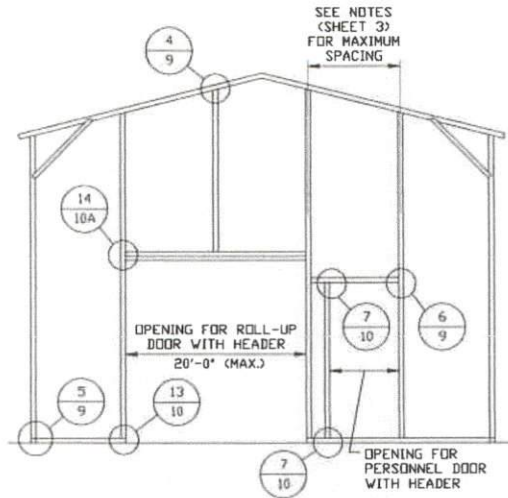

**TYPICAL BOX EAVE RAFTER END
WALL OPENINGS FRAMING SECTION**

SCALE: NTS

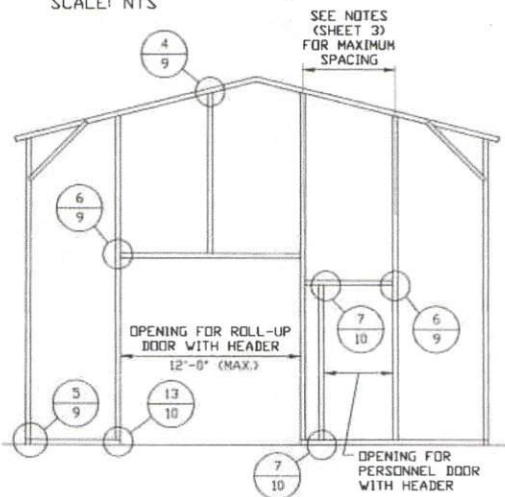

**TYPICAL BOX EAVE RAFTER END
WALL OPENINGS FRAMING SECTION**

SCALE: NTS

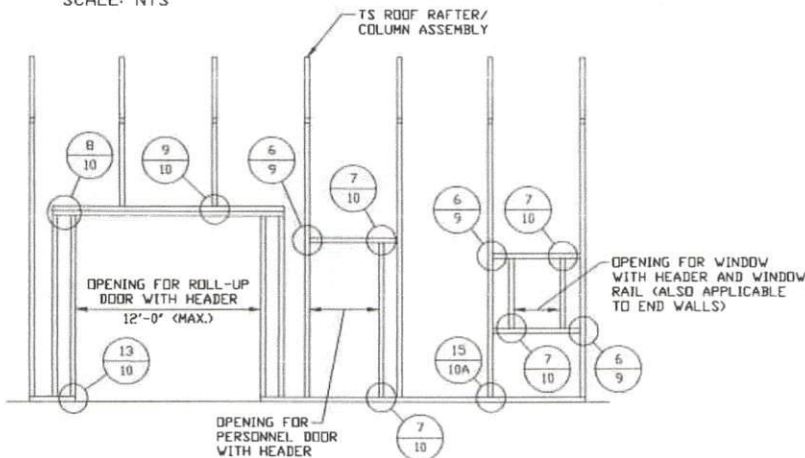

**TYPICAL BOX EAVE RAFTER
SIDE WALL OPENINGS FRAMING SECTION**

SCALE: NTS

**MOORE AND ASSOCIATES
ENGINEERING AND CONSULTING, INC.**

DRAWN BY: JG

CHECKED BY: PH

PROJECT MGR: WSM

CLIENT: NC CARPORTS

NC CARPORTS AND GARAGES, LLC
309 S. DEPOT STREET
PILOT MOUNTAIN, NC 27041
30'-0" x 16'-0" ENCLOSED STRUCTURE

DATE: 7-2-20

SHT. 8

SCALE: NTS

DWG. NO: SK-3

18315S/19179S/
JOB NO: 20176S

REV: 2

THIS DOCUMENT IS THE PROPERTY OF MOORE AND ASSOCIATES ENGINEERING AND CONSULTING. THE UNAUTHORIZED REPRODUCTION, COPYING, OR OTHERWISE USE OF THIS DOCUMENT IS STRICTLY PROHIBITED AND ANY INFRINGEMENT THEREUPON MAY BE SUBJECT TO LEGAL ACTION.

BOX EAVE RAFTER END WALL AND SIDE WALL OPENINGS

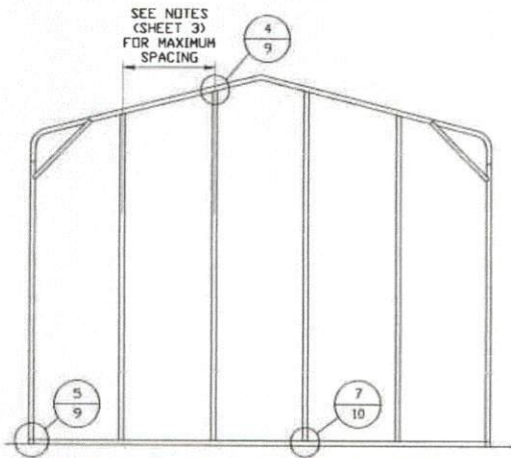

**TYPICAL BOX EAVE RAFTER
END WALL FRAMING SECTION**

SCALE: NTS

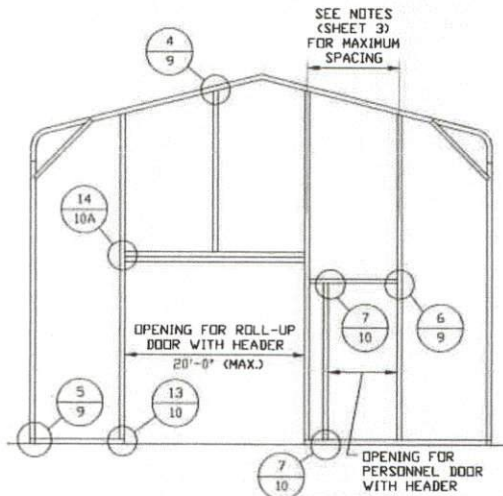

**TYPICAL BOX EAVE RAFTER END
WALL OPENINGS FRAMING SECTION**

SCALE: NTS

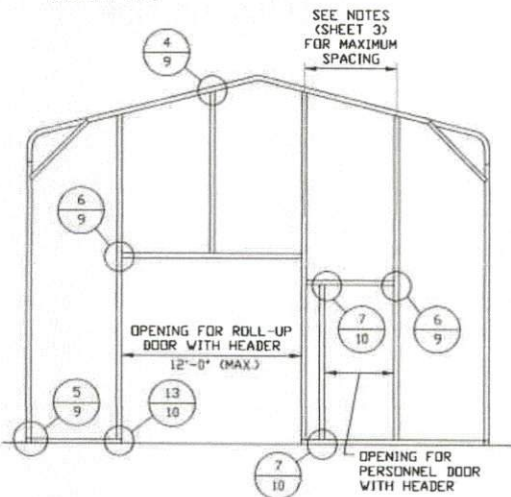

**TYPICAL BOX EAVE RAFTER END
WALL OPENINGS FRAMING SECTION**

SCALE: NTS

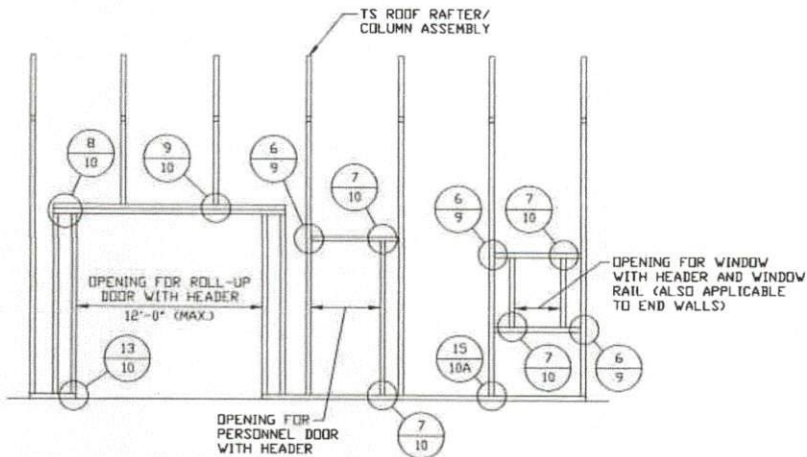

**TYPICAL BOX EAVE RAFTER
SIDE WALL OPENINGS FRAMING SECTION**

SCALE: NTS

**MOORE AND ASSOCIATES
ENGINEERING AND CONSULTING, INC.**

DRAWN BY: JG

CHECKED BY: PH

PROJECT MGR: WSM

CLIENT: NC CARPORTS

NC CARPORTS AND GARAGES, LLC
309 S. DEPOT STREET
PILOT MOUNTAIN, NC 27041
30'-0" x 16'-0" ENCLOSED STRUCTURE

DATE: 7-2-20

SHT. BA

SCALE: NTS

DVG. NO.: SK-3

**19315S/19179S/
JOB NO.:** 20176S

REV.: 2

THIS DOCUMENT IS THE PROPERTY OF MOORE AND ASSOCIATES ENGINEERING AND CONSULTING. THE UNAUTHORIZED REPRODUCTION, COPYING, OR OTHERWISE USE OF THIS DOCUMENT IS STRICTLY PROHIBITED AND ANY INFRINGEMENT THEREUPON MAY BE SUBJECT TO LEGAL ACTION.

CONNECTION DETAILS

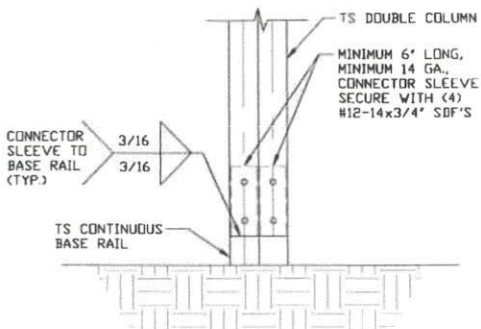

3A

POST/BASE RAIL CONNECTION DETAIL

SCALE: NTS

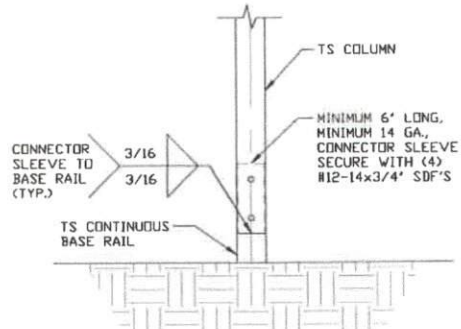

3B

POST/BASE RAIL CONNECTION DETAIL

SCALE: NTS

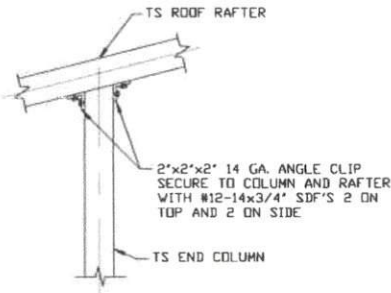

4

END COLUMN/RAFTER CONNECTION DETAIL

SCALE: NTS

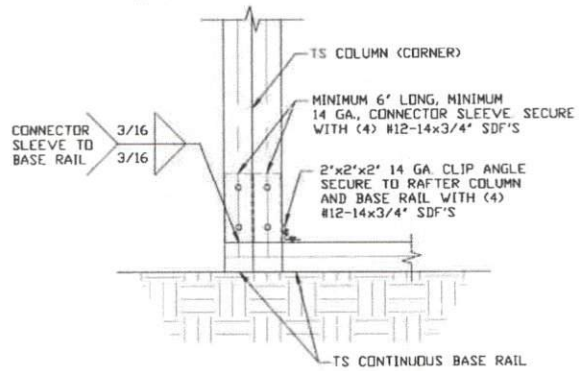

5A

END COLUMN/BASE RAIL CONNECTION DETAIL

SCALE: NTS

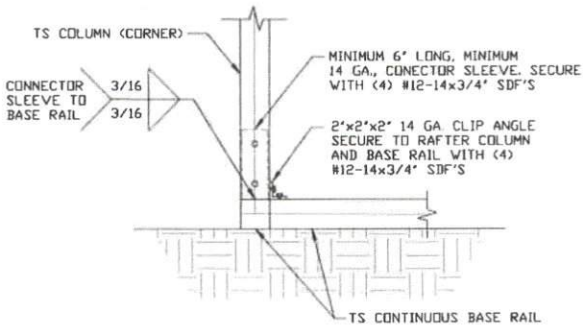

5B

END COLUMN/BASE RAIL CONNECTION DETAIL

SCALE: NTS

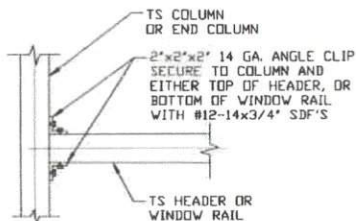

6

COLUMN OR WINDOW RAIL TO POST CONNECTION DETAIL

SCALE: NTS

**MOORE AND ASSOCIATES
ENGINEERING AND CONSULTING, INC.**

DRAWN BY: JG

CHECKED BY: PH

PROJECT MGR: WSM

CLIENT: NC CARPORTS

NC CARPORTS AND GARAGES, LLC
309 S. DEPOT STREET
PILOT MOUNTAIN, NC 27041
30'-0" x 16'-0" ENCLOSED STRUCTURE

DATE: 7-2-20

SHT. 9

SCALE: NTS

DWG. NO: SK-3

18315S/19179S/

JOB NO: 20176S

REV: 2

THIS DOCUMENT IS THE PROPERTY OF MOORE AND ASSOCIATES ENGINEERING AND CONSULTING. THE UNAUTHORIZED REPRODUCTION, COPYING, OR OTHERWISE USE OF THIS DOCUMENT IS STRICTLY PROHIBITED AND ANY INFRINGEMENT THEREUPON MAY BE SUBJECT TO LEGAL ACTION.

CONNECTION DETAILS

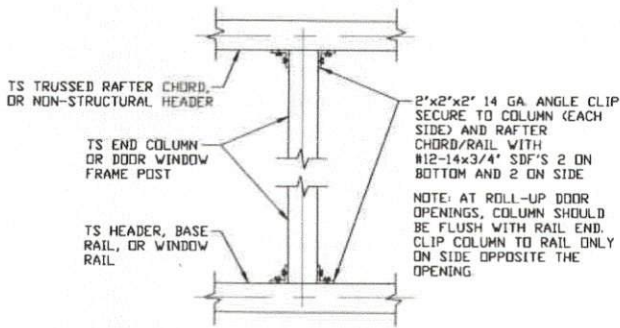

7 COLUMN TO HEADER, BASE RAIL, OR WINDOW RAIL CONNECTION DETAIL

SCALE: NTS

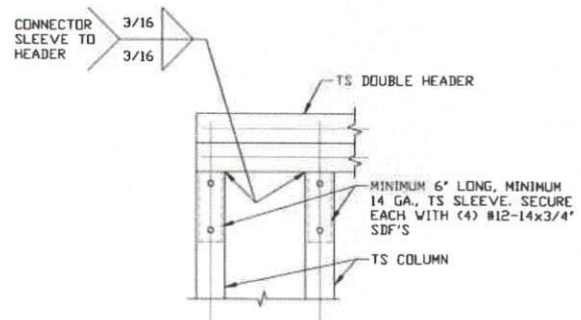

8 DOUBLE HEADER/COLUMN CONNECTION DETAIL

SCALE: NTS

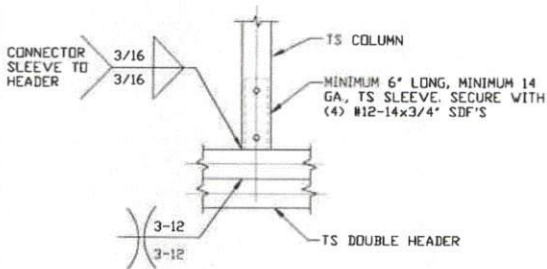

9 COLUMN/DOUBLE HEADER CONNECTION DETAIL

SCALE: NTS

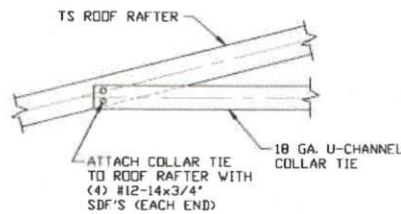

10 COLLAR TIE CONNECTION DETAIL

SCALE: NTS

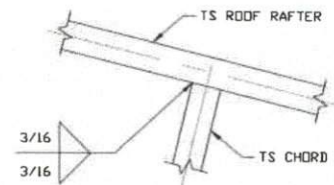

11 RAFTER TO CHORD CONNECTION DETAIL

SCALE: NTS

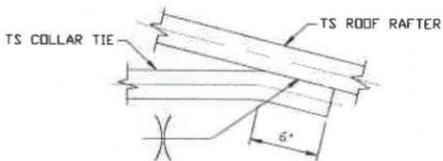

12 COLLAR TIE CONNECTION DETAIL

SCALE: NTS

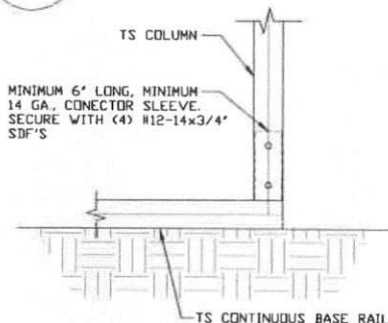

13 COLUMN/BASE RAIL CONNECTION DETAIL

SCALE: NTS

**MOORE AND ASSOCIATES
ENGINEERING AND CONSULTING, INC.**

DRAWN BY: JG

CHECKED BY: PH

PROJECT MGR: WSM

CLIENT: NC CARPORTS

NC CARPORTS AND GARAGES, LLC
309 S. DEPOT STREET
PILOT MOUNTAIN, NC 27041
30'-0" x 16'-0" ENCLOSED STRUCTURE

DATE: 7-2-20

SHT. 10

SCALE: NTS

DWG. NO: SK-3

18315S/19179S/
JOB NO: 20176S

REV: 2

THIS DOCUMENT IS THE PROPERTY OF MOORE AND ASSOCIATES ENGINEERING AND CONSULTING. THE UNAUTHORIZED REPRODUCTION, COPYING, OR OTHERWISE USE OF THIS DOCUMENT IS STRICTLY PROHIBITED AND ANY INFRINGEMENT THEREUPON MAY BE SUBJECT TO LEGAL ACTION.

CONNECTION DETAILS

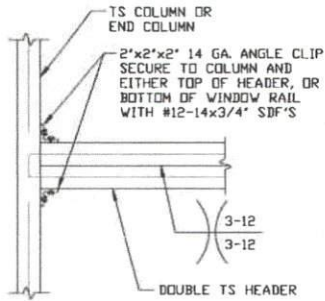

**DOUBLE HEADER
TO COLUMN
CONNECTION DETAIL**

14

SCALE: NTS

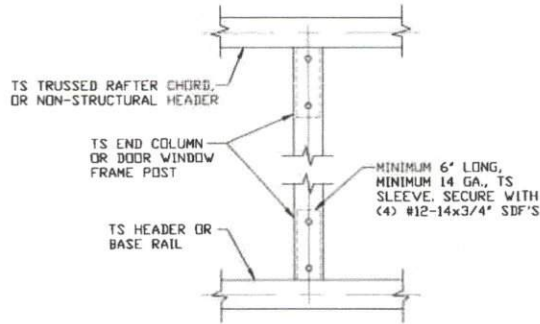

**COLUMN TO HEADER
OR BASE RAIL
CONNECTION DETAIL**

15

SCALE: NTS

**MOORE AND ASSOCIATES
ENGINEERING AND CONSULTING, INC.**

DRAWN BY: JG

CHECKED BY: PH

PROJECT MGR: WSM

CLIENT: NC CARPORTS

NC CARPORTS AND GARAGES, LLC
309 S. DEPOT STREET
PILOT MOUNTAIN, NC 27041
30'-0" x 16'-0" ENCLOSED STRUCTURE

DATE: 7-2-20

SCALE: NTS

18315S/19179S/
JOB NO: 20176S

SHT. 10A

DWG. NO: SK-3

REV: 2

THIS DOCUMENT IS THE PROPERTY OF MOORE AND ASSOCIATES ENGINEERING AND CONSULTING. THE UNAUTHORIZED REPRODUCTION, COPYING, OR OTHERWISE USE OF THIS DOCUMENT IS STRICTLY PROHIBITED AND ANY INFRINGEMENT THEREUPON MAY BE SUBJECT TO LEGAL ACTION.

BOX EAVE RAFTER LEAN-TO OPTIONS

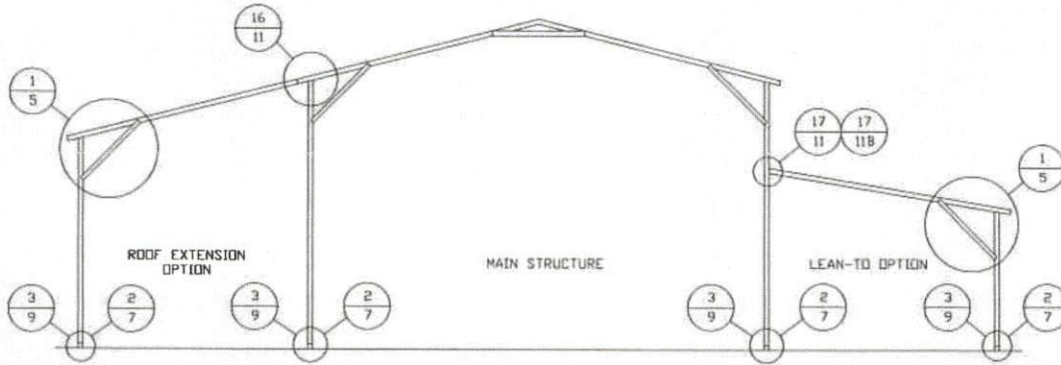

TYPICAL BOX EAVE RAFTER LEAN-TO OPTIONS FRAMING SECTION (BOTH OPTIONS SHOWN)

SCALE: NTS
 MAXIMUM WIDTH OF SINGLE MEMBER ROOF EXTENSION AND LEAN-TO OPTION IS 12'-0".
 MAXIMUM WIDTH OF DOUBLE MEMBER ROOF EXTENSION AND LEAN-TO OPTION IS 16'-0".

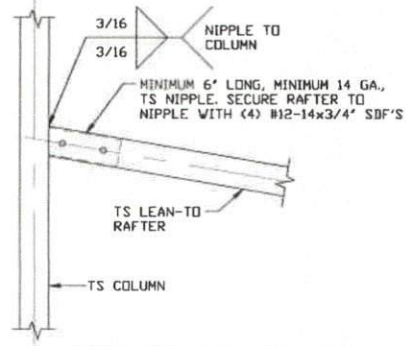
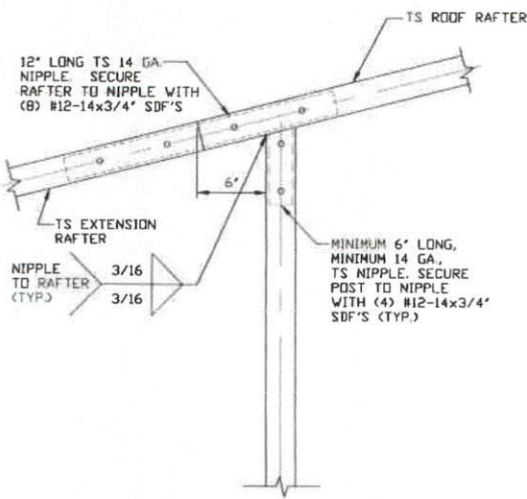

LEAN-TO RAFTER TO RAFTER POST CONNECTION DETAIL FOR WIDTHS \leq 12'-0"

17A

SCALE: NTS

ROOF EXTENSION RAFTER/CORNER POST DETAIL FOR WIDTHS \leq 12'-0"

16

SCALE: NTS

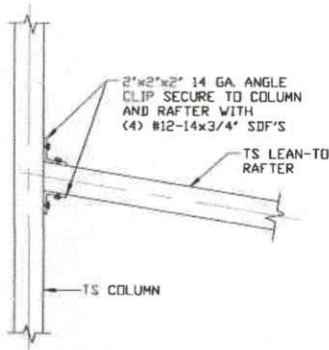

LEAN-TO RAFTER TO RAFTER POST CONNECTION DETAIL FOR WIDTHS \leq 12'-0"

17B

SCALE: NTS

**MOORE AND ASSOCIATES
 ENGINEERING AND CONSULTING, INC.**

DRAWN BY: JG

CHECKED BY: PH

PROJECT MGR: WSM

CLIENT: NC CARPORTS

NC CARPORTS AND GARAGES, LLC
 309 S. DEPOT STREET
 PILOT MOUNTAIN, NC 27041
 30'-0" x 16'-0" ENCLOSED STRUCTURE

DATE: 7-2-20

SHT. 11

SCALE: NTS

DWG. NO: SK-3

18315S/19179S/
 JOB NO: 20176S

REV: 2

THIS DOCUMENT IS THE PROPERTY OF MOORE AND ASSOCIATES ENGINEERING AND CONSULTING. THE UNAUTHORIZED REPRODUCTION, COPYING, OR OTHERWISE USE OF THIS DOCUMENT IS STRICTLY PROHIBITED AND ANY INFRINGEMENT THEREUPON MAY BE SUBJECT TO LEGAL ACTION.

BOX EAVE RAFTER LEAN-TO OPTIONS

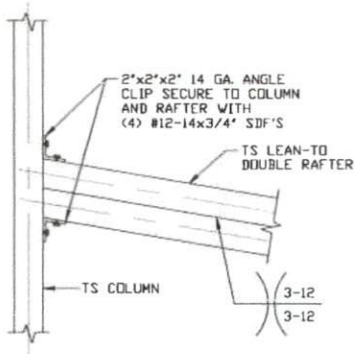

LEAN-TO RAFTER TO RAFTER
POST CONNECTION DETAIL FOR
WIDTHS 12'-0" < TO ≤ 16'-0"

17C

SCALE: NTS

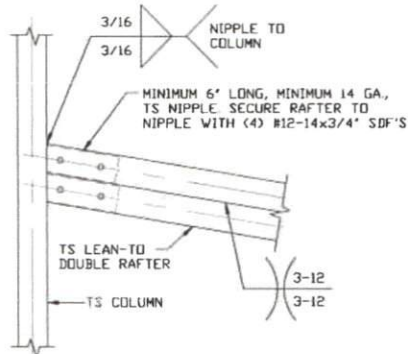

LEAN-TO RAFTER TO RAFTER
POST CONNECTION DETAIL FOR
WIDTHS 12'-0" < TO ≤ 16'-0"

17D

SCALE: NTS

MOORE AND ASSOCIATES
ENGINEERING AND CONSULTING, INC.

DRAWN BY: JG

CHECKED BY: PH

PROJECT MGR: WSM

CLIENT: NC CARPORTS

NC CARPORTS AND GARAGES, LLC
309 S. DEPOT STREET
PILOT MOUNTAIN, NC 27041
30'-0" x 16'-0" ENCLOSED STRUCTURE

DATE: 7-2-20

SHT. 11A

SCALE: NTS

DWG. NO: SK-3

18315S/19179S/
JOB NO: 20176S

REV: 2

THIS DOCUMENT IS THE PROPERTY OF MOORE AND ASSOCIATES ENGINEERING AND CONSULTING. THE UNAUTHORIZED REPRODUCTION, COPYING, OR OTHERWISE USE OF THIS DOCUMENT IS STRICTLY PROHIBITED AND ANY INFRINGEMENT THEREUPON MAY BE SUBJECT TO LEGAL ACTION.

BOW EAVE RAFTER LEAN-TO OPTIONS

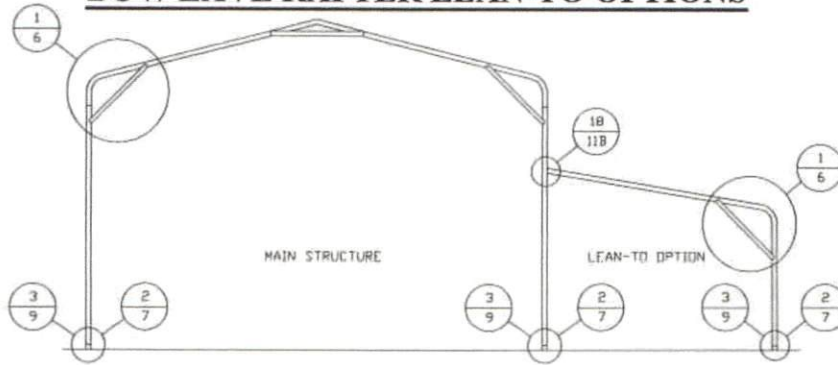

TYPICAL BOW EAVE RAFTER LEAN-TO OPTIONS FRAMING SECTION

SCALE: NTS
 MAXIMUM WIDTH OF SINGLE MEMBER LEAN-TO OPTION IS 12'-0".
 MAXIMUM WIDTH OF DOUBLE MEMBER LEAN-TO OPTION IS 16'-0".

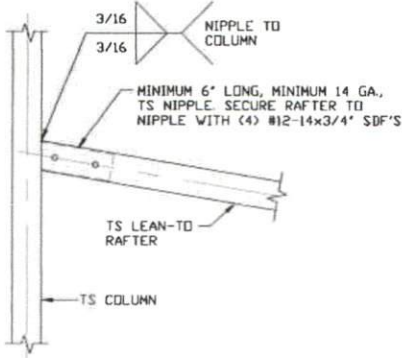

18A
 LEAN-TO RAFTER TO RAFTER POST CONNECTION DETAIL FOR WIDTHS $\leq 12'-0"$

SCALE: NTS

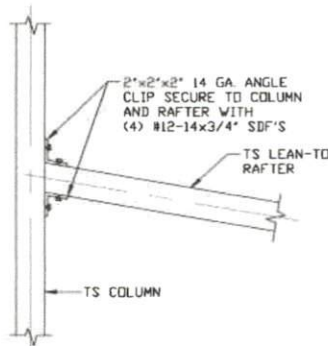

18B
 LEAN-TO RAFTER TO RAFTER POST CONNECTION DETAIL FOR WIDTHS $\leq 12'-0"$

SCALE: NTS

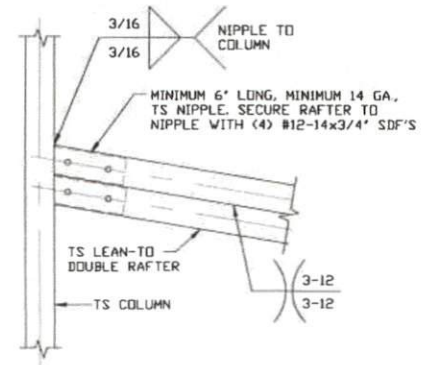

18C
 LEAN-TO RAFTER TO RAFTER POST CONNECTION DETAIL FOR WIDTHS $12'-0' < TO \leq 16'-0'$

SCALE: NTS

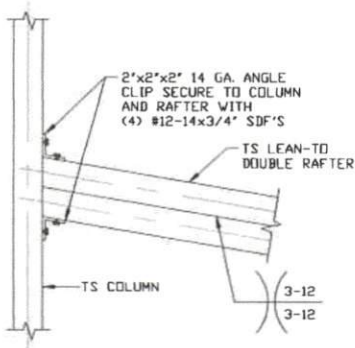

18D
 LEAN-TO RAFTER TO RAFTER POST CONNECTION DETAIL FOR WIDTHS $12'-0' < TO \leq 16'-0'$

SCALE: NTS

MOORE AND ASSOCIATES
 ENGINEERING AND CONSULTING, INC.

DRAWN BY: JG

CHECKED BY: PH

PROJECT MGR: WSM

CLIENT: NC CARPORTS

NC CARPORTS AND GARAGES, LLC
 309 S. DEPOT STREET
 PILOT MOUNTAIN, NC 27041
 30'-0" x 16'-0" ENCLOSED STRUCTURE

DATE: 7-2-20

SHT. 11B

SCALE: NTS

DWG. NO: SK-3

18315S/19179S/
 JOB NO: 20176S

REV: 2

THIS DOCUMENT IS THE PROPERTY OF MOORE AND ASSOCIATES ENGINEERING AND CONSULTING. THE UNAUTHORIZED REPRODUCTION, COPYING, OR OTHERWISE USE OF THIS DOCUMENT IS STRICTLY PROHIBITED AND ANY INFRINGEMENT THEREUPON MAY BE SUBJECT TO LEGAL ACTION.

BOX EAVE RAFTER VERTICAL ROOF/SIDING OPTION

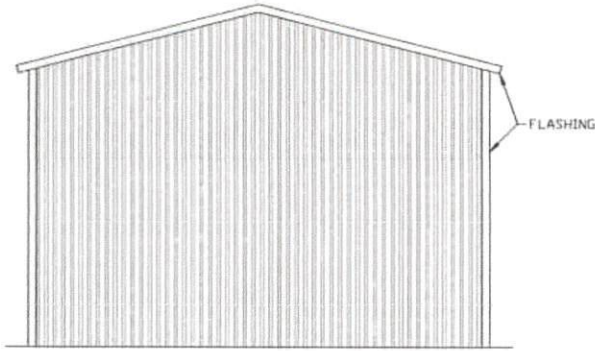

**TYPICAL END ELEVATION
VERTICAL ROOF/SIDING**
SCALE: NTS

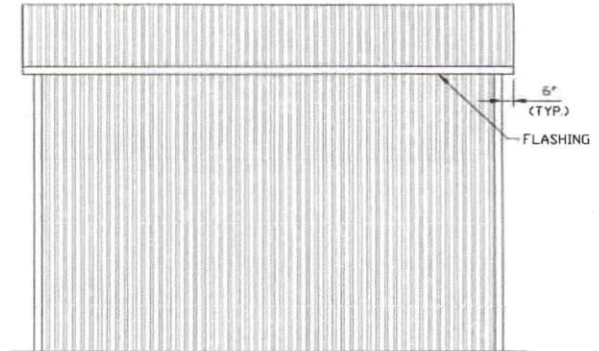

**TYPICAL SIDE ELEVATION
VERTICAL ROOF/SIDING**
SCALE: NTS

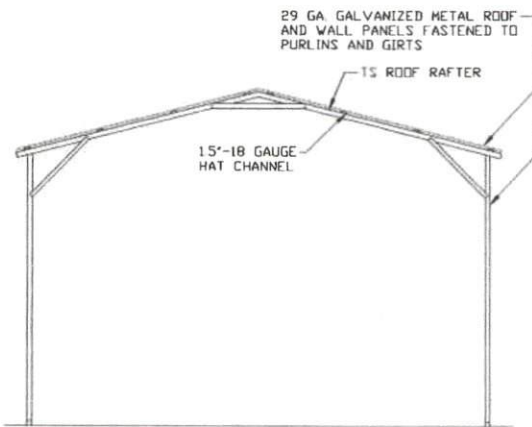

**TYPICAL SECTION
VERTICAL ROOF/SIDING OPTION**
SCALE: NTS

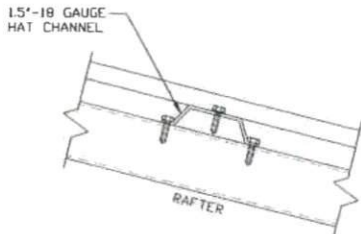

PANEL ATTACHMENT
(ALTERNATE FOR VERTICAL ROOF PANELS)
SCALE: NTS

**MOORE AND ASSOCIATES
ENGINEERING AND CONSULTING, INC.**

DRAWN BY: JG

CHECKED BY: PH

PROJECT MGR: WSM

CLIENT: NC CARPORTS

NC CARPORTS AND GARAGES, LLC
309 S. DEPOT STREET
PILOT MOUNTAIN, NC 27041
30'-0" x 16'-0" ENCLOSED STRUCTURE

DATE: 7-2-20

SHT. 12

SCALE: NTS

DWG. NO: SK-3

18315S/19179S/
JOB NO: 20176S

REV: 2

THIS DOCUMENT IS THE PROPERTY OF MOORE AND ASSOCIATES ENGINEERING AND CONSULTING. THE UNAUTHORIZED REPRODUCTION, COPYING, OR OTHERWISE USE OF THIS DOCUMENT IS STRICTLY PROHIBITED AND ANY INFRINGEMENT THEREUPON MAY BE SUBJECT TO LEGAL ACTION.

BOX EAVE RAFTER VERTICAL ROOF/SIDING OPTION

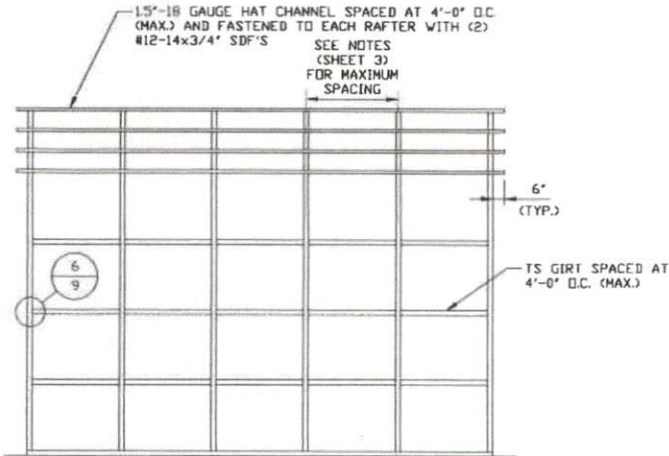

**TYPICAL FRAMING SECTION
VERTICAL ROOF/SIDING OPTION
WITH TS GIRTS**

SCALE: NTS

**MOORE AND ASSOCIATES
ENGINEERING AND CONSULTING, INC.**

DRAWN BY: JG

CHECKED BY: PH

PROJECT MGR: WSM

CLIENT: NC CARPORTS

NC CARPORTS AND GARAGES, LLC
309 S. DEPOT STREET
PILOT MOUNTAIN, NC 27041
30'-0" x 16'-0" ENCLOSED STRUCTURE

DATE: 7-2-20

SHT. 12A

SCALE: NTS

DWG. NO: SK-3

18315S/19179S/
JOB NO: 20176S

REV: 2

THIS DOCUMENT IS THE PROPERTY OF MOORE AND ASSOCIATES ENGINEERING AND CONSULTING. THE UNAUTHORIZED REPRODUCTION, COPYING, OR OTHERWISE USE OF THIS DOCUMENT IS STRICTLY PROHIBITED AND ANY INFRINGEMENT THEREUPON MAY BE SUBJECT TO LEGAL ACTION.