

**ENGINEERS
PLANNERS
CONSULTANTS**

305 NORTH OAKLAND AVENUE • P.O. BOX 490 • NAPPANEE, INDIANA 46550
WEB: WWW.NTAINC.COM

PHONE: 574-773-7975
FAX: 574-773-2732

January 10, 2019

Mr. Mike Hamm, PE
State of North Carolina
Department of Insurance
Manufactured Building Division
322 Chapanoke Road
Suite 200
Raleigh, NC 27603

RE: CMH Manufacturing, Inc. #958
Model: 5531-28W-3BR for NC

Dear Mr. Hamm,

Enclosed, you will find one (1) copy of the above mentioned project for your files.

Should you have any questions or comments, please contact me at your earliest convenience.

Sincerely,

David Richter

David Richter
Account Manager

Enclosures

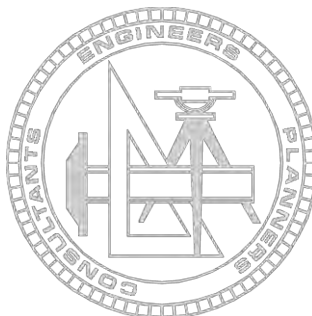

CMH

Manufacturing, Inc.
engineering department - modular

APPROVED BY



Approval of this document does not authorize or approve any deviation or deviations from the requirements of applicable State Laws.
David Richter

Date:
1/8/2019

TYPE : MODULAR

MODEL PLAN INDEX

Model #	5531-28WIDE-3BR	State
Manufacturer	CMH Manufacturing, Inc.	NC
Brand Name	CLAYTON	
Unit Size	26'-8"x72'-0"	
Description	3 BEDROOM / 2 BATH	

Category	Document Description	Page or Sheet #
Index	Model Plan Index	IX-1
Technical Sheet	Light & Vent	TS-1
Technical Sheet	Energy Compliance	Prescriptive
Technical Sheet	HVAC System Calc	ATTACHED
Technical Sheet	Electrical Load Calc	TS-5
Model Plan	Cover Sheet	1-0
Model Plan	Cross Section / Fastening Schedule	1-0.2
Model Plan	Master Plan-Glamour Master Bath	1-1
Model Plan	Master Plan-Std Master Bath	1-2
Model Plan	HVAC Layout	4-3A
Model Plan	DWV Plumbing Schematic	8-1
Model Plan	Supply Plumbing	9-1
Model Plan	Electrical Plan-G.M.Bath	11-1
Model Plan	Electrical Plan-S.M.Bath	11-2
Model Plan	Exterior Elevations - Front & Right	20-1
Model Plan	Exterior Elevations - Rear & Left	20-2
Model Plan	OFF Frame Foundation	21-30PSF
Technical Sheet	OFF-Frame Foundation Calculations	ATTACHED
Model Plan	ON Frame Foundation	21-30PS
Model Plan	ON Frame Foundation Calculations	ATTACHED
Model Plan	Dryer Installation Details	4-1
Model Plan	Electrical Legend	TS-6
Technical Sheet	PLUMBING PLAN	PLN-1.8
Technical Sheet	TRUSSES	ATTACHED
SEE APPROVED MODULAR MANUAL FOR ;		
1. SECTIONS		2. TYPICAL DETAILS
3. REQUIRED CONSTRUCTION METHODS		4. MATERIALS

CMH

Manufacturing, Inc.
engineering department - modular

REVISIONS		
DATE :	REVISION BY :	GCK
January 8, 2019	REVISION DATE :	

TECHNICAL SHEET FOR LIGHT / VENT DATA

MODEL NUMBER	5531-28WIDE-3BR	
SIZE OF UNIT	26'-8"x72'-0"	
WINDOW SQ. FTG. STD.		
WINDOW SQ. FTG. W/ OPT.		
FIGURED FOR :	CLAYTON WINDOWS	
PERCENTAGE OF LIGHT REQ'D.	8%	
PERCENTAGE OF VENT REQ'D.	4%	

Room	Area	Square Footage		Required		Percentage of		Artificial Light	Artificial Vent
		Light	Vent	Light	Vent	Light	Vent		
MASTER BEDROOM	219.7	24.4	12.4	17.6	8.8	11.1%	5.6%		
LIVING ROOM	276.3	24.4	12.4	22.1	11.1	8.8%	4.5%		
BEDROOM 2	150.4	12.2	6.2	12.0	6.0	8.1%	4.1%		
BEDROOM 3	153.6	24.4	12.4	12.3	6.1	15.9%	8.1%		
KITCHEN	177.0	10.1	2.2	14.2	7.1	5.7%	1.2%	YES	YES
DINING ROOM	121.7	24.4	12.4	9.7	4.9	20.0%	10.2%		
DEN	187.7	36.6	18.6	15.0	7.5	19.5%	9.9%		

APPROVED BY



1/10/2019

David Richter

Approval of this document does not authorize or approve any deviation or deviations from the requirements of applicable State Laws.

APPLICATION ENGINEERING FOR HEATING AND COOLING

CMH Mfg., Inc.
2225 South Holden Road
Richfield, NC 27417-0386

Manufacturer's Model #: 5531-28W-3BR-NC
HVAC System Type: INFLOOR STRAIGHT ALUM. WITH INLINE REG - **CMH DESIGN** -

Prepared By LaSalle Air Systems 1/9/2019 (Method & Output © 2019)
All rights reserved: this information proprietary to LaSalle Bristol Co. and CMH Mfg., Inc.

Calculations on this page are based on design standards set forth in ASHRAE and ACCA Manuals J Rev 8.2 and D Rev 1.1. System registers are NOT located for best distribution based on Manual T. Design calculations are based on worst case orientation. Duct & register sizes do not meet Manual D specs.

ENTIRE HOUSE VALUES - DESIGN ZONE: NC, Region 3 NCECC (2018)/IECC (2015NC) 34N Latitude

COOLING LOAD: 35,246 Btuh for Outside Temp/Humidity of 94 ° F (34 C)/ 50% and Inside reduced to 75 ° F (23 C)/ 50%

HEATING LOAD: 31,024 Btuh based on outside temp of 22 ° F (-6 C) with inside temp raised to 72 ° F (22 C)

Crawlspace is not heated by the primary air handler.

Actual UA = 322.6 Max UA (Table R402.1.2) = 344.8
Use net wall area, not gross wall

CONSTRUCTION DETAILS & U / SHGC VALUES: (22+Non-ins Rim - 15 - 38)

Total Cond. Floor Area:	1920.00 s.f.	TRUE Outside Perimeter:	197.33	ft	
Level 1 Ceiling:	108 to 108 in.	Level 2 Ceiling:	0 to 0 in.	Level 3 Ceiling:	0 to 0 in.
Primary Wall Area:	1526.13 s.f. (Net)	Dark Roof(U):	0.027	FLOOR DUCTS (U):	0.0444 Duct TEL
Secondary Wall Area:	0.00 s.f. (Net)	Prim Wall (U):	0.070	ATTIC DUCTS (U):	0.125 392.4 ft
TOTAL Low-E window	212.10 s.f.	Sec Wall (U):	0.035	EXT. DUCTS (U):	0.125
TOTAL Patio Door	0.00 s.f.	Exp Floor(U):	0.044	INFLOOR DUCT AREA:	411.67 S.F. @ 50 TD/ 28.2 TD
TOTAL Glass Block	0.00 s.f.	Low-E wll	0.350 / 0.28	ATTIC DUCT AREA:	72.364 S.F.(return) @ 90 TD/ 91.1 TD
TOTAL Skylite	0.00 s.f.	Patio Doc	0.330 / 0.27	EXT. DUCT AREA:	50.265 S.F. @ 90 TD/ 47 TD
TOTAL Door1 Area:	37.78 s.f.	Glass Blc	0.510 / 0.41	PEOPLE:	4 4568.8 Btuh Total Appliances
TOTAL Door2 Area:	0.00 s.f.	Skylite	0.790 / 0.64	FIREPLACES:	0
All Glass % of Floor:	11.05 %	Door 1:	0.140	DUCT GAIN:	@ Semi-Tight 2640 Btuh
All Glass % of Wall:	11.94 %	Door 2:	0.670	DUCT LOSS:	5245 Btuh
LATENT GAIN:	8788 Btuh			Summer Infiltr (7.5 mph):	39.7 cfm
Mech. Ventilation :	105.12 cl(49.6 L/s)	Altitude:	500 ft	Winter Infiltration (15 mph):	74.9 cfm @ Semi-Tight

ROOM BY ROOM VALUES:

1170.8 FPM, max velocity in trunk #: 3
0.15 Max pressure at A/H

Heat Exiting Furnace: 89 deg A/C Exiting : 52 deg
Actual heating and cooling required in each room and flow set to maximum of either heating or cooling

ROOM NAME	HEATING LOSS (Btu)	COOLING GAIN (Btu)	CFM DIST	Cooling Air Values for 3.5 ton unit		Heating Air Values for 40 10.0 KW 90 % Gas/Oil Elec			Maximum A/C capacity Calibrated Blower Test Btuh (alt adj)
				CFM	Btuh	CFM	Btuh	E Btuh	
Den h	4,071	5,236	183	276	7,122	258	6,049	5,734	11,000
Bath #2 h	1,043	858	47	132	3,415	124	2,901	2,749	5,275
Utility h	1,619	1,468	73	55	1,418	51	1,204	1,141	2,195
Dining Room h	2,498	3,258	113	203	5,237	190	4,448	4,216	7,969
Kitchen h	2,489	2,928	112	106	2,731	99	2,320	2,199	4,156
W.I.C. 1 h	830	665	37	109	2,809	102	2,386	2,261	4,275
M. Bath h	2,840	3,250	128	71	1,835	67	1,559	1,477	2,797
M. Bedroom h	4,356	4,903	196	182	4,710	171	4,001	3,792	7,280
Living Room h	4,264	4,934	192	173	4,471	162	3,798	3,599	6,864
Bedroom #3 h	3,550	4,163	160	148	3,829	139	3,252	3,082	5,828
Bedroom #2 h	3,464	3,583	156	156	4,036	146	3,429	3,249	6,144
TOTALS	31,024	35,246	1,398	1,612	41,612	1,509	35,346	33,500	63,785

APPROVED BY
NIA INC.
1/10/2019
Approval of this document does not authorize or approve any deviation or deviations from the requirements of applicable State Laws.
David Richter

APPLICATION ENGINEERING DUCT AIR FLOW AND SIZING WORKSHEET (MANUAL D)

Manufacturer: **CMH Mfg., Inc.**
2225 South Holden Road
Richfield, NC 27417-0386

Model #: **5531-28W-3BR-NC**
HVAC System Type: **INFLOOR STRAIGHT ALUM. WITH INLINE REG - CMH DESIGN -**
Design Zone: **NC, Region 3 NCECC (2018)/IECC (2015NC)**

Prepared by LaSalle Air Systems 1/9/2019 All rights reserved. This information proprietary to LaSalle Bristol Co. and CMH Mfg., Inc.
Calculations include factors for duct air temperature change and pressure drops through ducts. All joints are tightly fitted or sealed.

Blower CFM 1668 @ 0.7 E.S.P. TEL= 441.433 FR= 0.0883 (A/C Coil included)
Altitude = 500 ft

BRANCH DUCT LISTING ANALYSIS

BR #	Trunk #	Metal (ft)	F. G. (ft)	Flex (ft)	Bends/ Fittings(ft)	Total Eq. Length	Heat Btuh	Cool Btuh	Elec Heat cfm	User Input			Final Round Size	Final Velocity fpm		
										(Altitude Adj.)	Rectangle Size (i.d.) x (i.d.)	Round Size				
1 Utility	2	60	0	7	279.4	346.4	1,619	1,468	87	56	87	5.79	5.0	638.4		
2 Bath #2	2	61	0	0	198.4	259.4	1,043	858	56	33	56	4.48	4	9	6.4	224.3
3 Den	2	61	0	0	188.4	249.4	2,008	2,582	108	99	108	5.65	4	9	6.4	431.8
4 Den	2	61	0	0	178.4	239.4	2,063	2,654	111	102	111	5.64	4	9	6.4	443.8
5 Dining Room	3	62	0	0	218.4	280.4	1,232	1,607	66	62	66	4.93	4	9	6.4	265.0
6 Dining Room	3	62	0	0	208.4	270.4	1,266	1,651	68	63	68	4.93	4	9	6.4	272.3
7 Kitchen	3	62	0	0	198.4	260.4	2,489	2,928	134	112	134	6.24	4	9	6.4	535.4
8 W.I.C. 1	3	62	0	0	188.4	250.4	830	665	45	26	45	4.09	4	9	6.4	178.6
9 M. Bath	3	61	0	15	266.1	342.1	2,840	3,250	153	125	153	7.26			6.0	777.7
10 Living Room	5	35	0	16	323.1	374.1	1,758	2,034	95	78	95	6.18	4	9	6.4	378.0
11 Bedroom #3	5	35	0	16	313.1	364.1	1,752	2,054	94	79	94	6.10	4	9	6.4	376.7
12 Bedroom #3	5	35	0	16	303.1	354.1	1,798	2,109	97	81	97	6.10	4	9	6.4	386.7
13 Bedroom #2	5	35	0	16	293.1	344.1	1,710	1,768	92	68	92	5.91	4	9	6.4	367.7
14 Bedroom #2	5	35	0	16	283.1	334.1	1,755	1,815	94	70	94	5.90	4	9	6.4	377.4
15 Living Room	6	36	0	16	303.1	355.1	2,506	2,900	135	111	135	7.04	4	9	6.4	539.0
16 M. Bedroom	6	36	0	16	293.1	345.1	2,497	2,810	134	108	134	6.96	4	9	6.4	537.0
17 M. Bedroom	6	35	0	22	335.4	392.4	1,860	2,093	100	80	100	6.45			6.0	509.3
N/A Other Rooms							-	-								
							31,024	35,246	1,668	1,354	1,668					

APPROVED BY
NIA INC. 1/10/2019
Approval of this document does not authorize or approve any deviation or deviations from the requirements of applicable State Laws.
David Richter

TRUNK DUCT LISTING ANALYSIS

TRUNK # 1	30	55	85.0	31,024	35,246	1668	13.81	12	14	14.2	1429.9
TRUNK # 2	30	133.422	163.4	6,733	7,562	362	8.33	5	14	8.9	744.8
TRUNK # 3	31	133.422	164.4	8,658	10,101	466	9.19	5	14	8.9	957.7
TRUNK # 4		16	208.166	224.2	15,634	17,583	841	12.25		12.0	1070.4
TRUNK # 5	34	224.166	258.2	8,772	9,781	472	10.20	5	14	8.9	970.3
TRUNK # 6	35	224.166	259.2	6,862	7,803	369	9.31	5	14	8.9	759.1
TRUNK # 7				-	-	0		0	0		
TRUNK # 8				-	-	0		0	0		
TRUNK # 9				-	-	0		0	0		
TRUNK # 10				-	-	0		0	0		
TRUNK # 11				-	-	0		0	0		
TRUNK # 12				-	-	0		0	0		
TRUNK # 13				-	-	0		0	0		
TRUNK # 14		7		-	-	0					
TRUNK # 15		29		-	-	0					
LONGEST RETURN DUCT		29	20	49		1668	13.28	18	24	22.7	556.1

APPLICATION ENGINEERING EQUIPMENT SELECTION AND SIZING WORKSHEET (MANUAL S)

Manufacturer: **CMH Mfg., Inc.**
2225 South Holden Road
Richfield, NC 27417-0386

Model #: **5531-28W-3BR-NC**
HVAC System Type: **INFLOOR STRAIGHT ALUM. WITH INLINE REG - CMH DESIGN -**
Design Zone: **NC, Region 3 NCECC (2018)/IECC (2015NC)**

Prepared by LaSalle Air Systems 1/9/2019 All rights reserved. This information proprietary to LaSalle Bristol Co. and CMH Mfg., Inc.

RESULTS FROM MANUAL-J CALCULATIONS: Worst Case Orientation

HEATING LOAD:	31,024 Btuh at 22 °	REQ'D BLOWER CFM:	1,612 cfm at altitude of 500 ft
SENSIBLE CLG LOAD:	26,458 Btuh at 94 °	Entering Air DRY Bulb:	76.2 ° Mech. Ventilation : 105
LATENT CLG LOAD:	8,788 Btuh at 94 °	Entering Air WET Bulb:	61.3 ° Entering Air RH: 53 %
GRAINS DIFFERENCE:	58	Outside wet bulb:	74.2 ° outside RH: 50.3 %

FILL IN BLANKS IN EACH SECTION FROM THE H.V.A.C. EQUIPMENT DATA CHARTS: (Do not use ARI Ratings!)

Air handler model #: _____ Condenser model #: _____

Blower Data Select blower speed in COOLING mode: _____
Blower CFM is between 1418 > _____ < 1918 for Total (External) Static Pressure between 0.6 > _____ < 0.8

Electric, Gas or Oil Furnace Select blower speed in HEATING mode: _____ Output Btuh is between 32575 > _____ < 43434
Blower CFM is between 552 > _____ < 652 for Temp. rise of 55-65
Blower CFM is between 652 > _____ < 797 for Temp. rise of 45-55
Blower CFM is between 797 > _____ < 1025 for Temp. rise of 35-45

Cooling Equipment S/T Ratio = 0.75 Leaving Temp = 52.6 ° TD = 22.4 °
At 94F outside, Total A/C output from 35950 btuh _____ to 40532 btuh is GOOD.
At 94F outside, Total A/C output from 40532 btuh _____ to 42295 btuh is MARGINAL.

Sensible Capacity is from 22063 btuh _____ to 30851 btuh
Latent Capacity is from 8612 btuh _____ to 13182 btuh

Mechanical Ventilation is 6.3 % of blower cfm. Dry bulb increases by: 1.1 ° Wet bulb increases by: 0.8 °

Heat Pump with Supplemental Heating Coils
Data from performace charts _____ btuh at _____ F outside
_____ btuh at _____ F outside
Data from load calculation 0 btuh at 72 F outside
31,024 btuh at 22 F outside

APPROVED BY
NIA INC. 1/10/2019
Approval of this document does not authorize or approve any deviation or deviations from the requirements of applicable State Laws.
David Richter

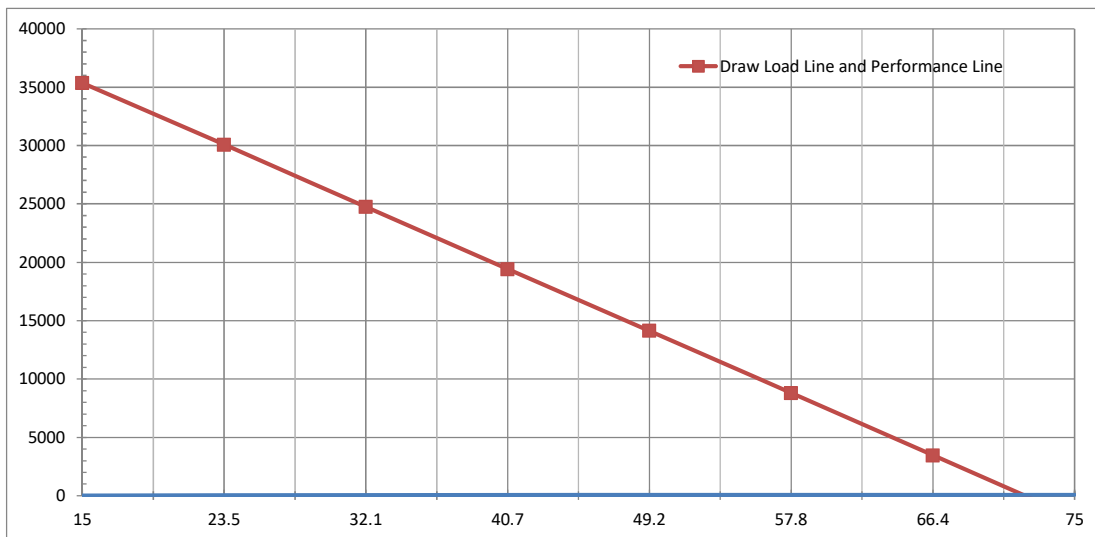

At winter design temperature of 22 F outside, the distance between the lines is _____ btuh
which is the Supplemental Heat divided by 3400 = _____ KW.

APPLICATION ENGINEERING INTERNATIONAL MECHANICAL CODE - Chapter 4 Ventilation Worksheet

Manufacturer: **CMH Mfg., Inc.**
2225 South Holden Road
Richfield, NC 27417-0386

Model #: **5531-28W-3BR-NC**
HVAC System Type: INFLOOR STRAIGHT ALUM. WITH INLINE REG - CMH DESIG
Design Zone: **NC, Region 3 NCECC (2018)/IECC (2015NC)**

Prepared by LaSalle Air Systems 1/9/2019 All rights reserved. This information proprietary to LaSalle Bristol Co. and CMH Mfg., Inc.

RESULTS FROM MANUAL-J CALCULATIONS: Worst Case Orientation

HEATING LOAD:	31,024 Btuh at 22 °	REQ'D BLOWER CFM:	1,612 cfm at altitude of 500 ft
SENSIBLE CLG LOAD:	26,458 Btuh at 94 °	Entering Air DRY Bulb:	76.2 ° Mech. Ventilation : 105
LATENT CLG LOAD:	8,788 Btuh at 94 °	Entering Air WET Bulb:	61.3 ° Entering Air RH: 53 %
GRAINS DIFFERENCE:	58	Outside wet bulb:	74.2 ° outside RH: 50 %

Natural or Mechanical: Test the infiltration at 50 Pa should result in 598.4 CFM infiltration being 2.078 ACH (to be confirmed by testing)

(5 ACH = 1440 CFM) (3 ACH = 864 CFM)

Mechanical ventilation is required

To Meet Natural Ventilation: Increase Openable Area by 140 %

ROOM NAME	Room Area	Openable Area		ROOM NAME	Room Area	Openable Area		
		Required	Built			Require	Built	
Den	210.0	8.4	22.50	Bedroom #3	215.6	8.6	15.00	
Bath #2	91.1	3.6	0.00	Bedroom #2	208.9	8.3	7.50	
Utility	121.1	4.8	0.00		0.0	0.0	0.00	
Dining Room	132.2	5.2	15.00		0.0	0.0	0.00	
Kitchen	188.9	7.5	7.05		0.0	0.0	0.00	
W.I.C. 1	67.8	2.7	0.00		0.0	0.0	0.00	
M. Bath	148.9	5.9	9.00		0.0	0.0	0.00	
M. Bedroom	248.9	9.9	15.00		0.0	0.0	0.00	
Living Room	286.7	11.4	15.00		0.0	0.0	0.00	
-----				-----				
TOTAL				TOTAL				
						1920.0	76.3	106.05

Mechanical Ventilation Is Required In These Areas To Meet IMC 2012/2015 Per Table 403.3.1.1:

SPACE CLASSIFICATIONS	Occupancy	Area	Outdoor Exhaust		ZONE AIR DISTRIBUTION	Air
			Air	Air		Flow
Private Living Area	4.0	1491.1	105.1	0.0	Floor Supply of Warm Air/Floor Return	1302
Private Kitchen	0.0	188.9	0.0	25.0	Floor Supply of Warm Air/Floor Return	105.8
Private Baths	0.0	240.0	0.0	90.0	Floor Supply of Warm Air/Floor Return	203.4
	0.0	0.0	0.0	0.0		0
	0.0	0.0	0.0	0.0		0
	0.0	0.0	0.0	0.0		0
-----						-----
Total	4.0	1,920.0	105.1	115.0		1,611
System Ventillation Efficiency:						1

APPROVED BY

1/10/2019
David Richter

Approval of this document does not authorize or approve any deviation or deviations from the requirements of applicable State Laws.

ELECTRICAL FEEDER CALCULATION

CMH Manufacturing, Inc. <i>engineering department - modular</i>	PAGE:	1 of 1
	DATE:	8-Jan-19
	BY:	GCK

MODEL NO.	5531-28WIDE-3BR	Per NEC 220-30
-----------	------------------------	----------------

1. LIGHTING LOAD:					
1st floor			2nd floor		
length =	72.00	FT.	length =	0.00	FT.
width =	26.67	FT.	width =	0.00	FT.
Total area =	1920	SQ. FT.	Minimum number of 15 Amp circuits =	4	
	X	3	VA		
TOTAL	5760	VA			

2. SMALL APPLIANCE LOAD:			3. LAUNDRY LOAD:		
Number of circuits	3		Number of circuits	1	
	X	1500	VA	X	1500
TOTAL	4500	VA	TOTAL	1500	VA

4. APPLIANCE LOAD:		
Electric Range =		12100 VA
Electric Water Heater =		5000 VA
Electric Clothes Dryer =		5600 VA
Cooktop =		0 VA
Wall Oven =		0 VA
Freezer =		1200 VA
Dishwasher & Disposal =		2376 VA
Gas furnace motor =		0 VA
Micro-wave oven		1200 VA

5. TOTAL OF OTHER LOADS (1, 2 & 3)		
	LEG A	
Lighting load =	5760	
Small appliance load =	4500	
Laundry =	1500	
Appliance load =	27476	
Sub-Total =	39236	
10000 VA @ 100% =	10000	
Remainder @ 40% =	11694	
Total =	21694	VA
	90.39	AMPS

6. HVAC LOAD:			
Lineal feet of baseboard heaters =		0	
Number of baseboard heater circuits =		0	
Total baseboard heater load =		0.0	Amps
Use 65% w/ less than 4 or 40% w/ 4 or more circuits (*)			
Electric furnace @ 65% (*)			
Circuit 1 =	40	Amps	26.00 Amps
Circuit 2 =	30	Amps	19.50 Amps
Air conditioner (*)			Amps
Total HVAC load (*- Use largest of these only) =		45.50	Amps

7. TOTAL OF ALL LOADS =	135.89	Amps
--------------------------------	---------------	------

APPROVED BY

 1/10/2019
 INC.
Approval of this document does not authorize or approve any deviation or deviations from the requirements of applicable State Laws.
 David Richter

Furn Size
12KW

DOOR AND WINDOW SCHEDULE

NOTE: FLOOR PLAN WINDOW SIZES WITH AN "SG" DESIGNATION REPRESENTS SAFETY GLAZING REQUIRED PER IRC SECTION R308.4

SIZES	ROUGH OPENING	LIGHT (@ 8%)	VENT (@ 4%)
14 X 40 WDW.	14 1/4" X 40 1/4"	2.50	1.30
24 X35 WDW.	24 1/4" X 35 1/4"	4.10	2.10
24 X54 WDW.	24 1/4" X 54 1/4"	6.80	3.50
30 X 60 WDW.	30 1/4" X 60 1/4"	9.90	5.20
36 X 35 WDW.	36 1/4" X 35 1/4"	6.60	3.40
36 X 54 WDW.	36 1/4" X 54 1/4"	10.80	5.60
36 X 60 WDW.	36 1/4" X 60 1/4"	12.20	6.20
36 X 72 WDW.	36 1/4" X 72 1/4"	14.90	7.70
36 X 08 WDW.	36 1/4" X 08 1/4"	0.50	0.00
36 x 12 WDW.	36 1/4" X 12 1/4"	1.10	0.00
64 x 35 WDW.	64 1/4" X 35 1/4"	11.50	2.60
58 x 35 WDW.	58 1/4" X 35 1/4"	10.10	2.20
DOORS			
2-8 X 6-8 DOOR	35 1/2" X 80"	-	-
3-0 X 6-8 DOOR	38" X 80"	-	-
PATIO DOOR	72" X 80"	33.6	16.8
ATRIUM DOOR	75 3/8" X 82 1/2"	21.15	17.3

FASTENING REQUIREMENTS: FOR DOORS AND WINDOWS, USE EITHER # 8 X 1" SCREWS, 7/16" X 1 1/2" X 16 GA. STAPLES, OR .092 X 2 1/4" PD NAILS, AT 12" ON CENTER MAXIMUM.

<u>DESIGN CRITERIA</u>	<u>CLASSIFICATION:</u>
- FLOOR LIVE LOAD = 40 PSF	- USE GROUP = R
- GROUND SNOW LOAD = 30 PSF	R3 RESIDENTIAL (NON-TRANSIENT)
- ATTIC LIVE LOAD = 10 PSF	- CONSTRUCTION TYPE IS V-B (UNPROTECTED)

- SEISMIC DESIGN CATEGORY "C"	- SOIL PROFILE CATEGORY "C"
- WIND EXPOSURE - 'C'	-ROOF MEAN HT 22'-0"
DESIGN WIND SPEED = 90 MPH	100 MPH 120 MPH
ULTIMATE WIND SPEED = 117 MPH	130 MPH 152 MPH

ATTENTION LOCAL INSPECTION DEPARTMENT

SET-UP INSTRUCTIONS FOR THIS MODULAR UNIT ARE INCLUDED BY ATTACHMENT TO THESE PLANS. ANY PLAN SET WHICH DOES NOT INCLUDE AN ATTACHMENT ENTITLED "SET UP MANUAL" IS INCOMPLETE

SET- UP INSTRUCTIONS

SEE SETUP MANUAL SENT WITH HOME

REQUIREMENTS FOR FIRESTOPPING

INSTALLATION OF NON- COMBUSTIBLE MATERIALS AROUND ALL OPENINGS THAT ARE VERTICAL PENETRATIONS IN THE FLR. AND CLG.

ATTENTION LOCAL INSPECTION DEPARTMENT

THE FOLLOWING ITEMS LISTED HAVE NOT BEEN COMPLETED BY CMH MFG, Inc., HAVE NOT BEEN INSPECTED BY NTA, INC AND ARE NOT CERTIFIED BY THE STATE OF NORTH CAROLINA MODULAR LABEL. CODE COMPLIANCES MUST BE DETERMINED BY THE LOCAL JURISDICTION FOR THE FOLLOWING:

- HVAC SYSTEM (SITE INSTALLATION AND CONNECTIONS)
- THIS UNIT MUST BE CONNECTED TO A PUBLIC WATER SUPPLY AND SEWER SYSTEM, IF THESE ARE AVAILABLE.

CODE COMPLIANCE

ALL PLANS MEET OR EXCEED THE FOLLOWING:

North Carolina State Building Code Compliance:
- NC Residential Code - 2018 Edition

- NC Electrical Code - 2017

APPROVED BY



Approval of this document does not authorize or approve any deviation or deviations from the requirements of applicable State Laws.
David Richter

NOTICE TO CONTRACTOR:
All construction must comply with current NC Building Codes and is subject to field inspection and verification.

APPROVED
Limited building only review
Permit holder responsible for full compliance with the code

10/07/2021



RIDGE BEAMS-SIZES AND MAX. SPAN CHART

RIDGE BM. CHART-SEE MATING WALL PG. RC-60.0 FOR MAX. CALCULATIONS-SEE MATING WALL PGS. CRC SECTION

Soffit materials for this unit assume that the building face will be 10 feet or greater from the property line when installed on site. Where the building face is less than 10 feet from the property line, underlayment materials and ventilation in accordance with Section R302.1.1,NC Residential Code, must be provided and installed at the site and inspected by the local jurisdiction

THERMAL ZONE REQUIREMENT

-THIS BUILDING DESIGN COMPLIES WITH OR EXCEEDS MINIMUM REQUIREMENTS FOR NORTH CAROLINA THERMAL ZONE 5
-MODEL IS DESIGNED TO MEET THERMAL ZONE 5 AND BELOW PER TABLE N1101.2 REFERENCED IN THE NORTH CAROLINA RESIDENTIAL CODE, 2018 EDITION FOR ONE & TWO FAMILY DWELLINGS. REScheck ANALYSIS AND COMPLIANCE REPORT FOR THERMAL ZONE CALCULATION IS PROVIDED FOR EACH SPECIFIC MODEL AND IS ATTACHED IN THE SUBMITTED MODEL APPROVAL PACKAGE.

BTUS PER HVAC CALCS
FURNANCE SIZE PER HVAC CALCS

INSULATION PACKAGES
PRESCRIPTIVE

MODULAR MANUAL REFERENCES

ITEMS BELOW ARE REFERENCED FOR NON PRESCRIPTIVE USE

FLOOR: ON FRAME CONSTRUCTION
DETAILS - SECTIONS ON FLOORS FOR ON FRAME: FL-500
CALCULATIONS - SEE CFL SECTION

FLOOR: OFF FRAME CONSTRUCTION
DETAILS - SECTIONS ON FLOORS FOR OFF FRAME: FL - 100

MARRIAGE WALLS - 2x CONSTRUCTION
DETAILS - MW-20.0, MW-30.0, MW-40.0
CALCULATIONS - SEE CMW SECTION

PLUMBING FIXTURES
SEE PAGE PLN - 1.8

ALL MODELS ARE AVAILABLE WITH FLOOR PLAN REVERSED FROM LEFT TO RIGHT AND / OR FRONT TO BACK.

MARRIAGE WALL COLUMNS SPAN CHART
DETAIL - SEE MATING WALL COLUMNS (PAGE MW-20.0)
CALCULATIONS - SEE CMW SECTION

INSTRUCTIONS ON FILLING OUT PLAN SET BEFORE CONSTRUCTION
YOU MUST CHECK THE APPROPREATE BOX OF WHAT THE STRUCTURE IS TO BE BUILT TO BEFORE PRODUCTION BEGINS. THE MARK SET MUST ACCOMPANY THE UNIT THROUGH THE PRODUCTION PROCESS.

EXTERIOR SIDEWALL HEADERS - SIZES AND MAXIMUM SPAN CHART
HEADER CHART - SEE EXTERIOR WALL PAGE EW - 20.0
CALCULATIONS - CEW SECTION

ATTENTION LOCAL INSPECTION DEPARTMENT:
IF THIS STRUCTURE IS IN A THERMAL ZONE MORE STRINGENT THAN THAT LISTED ON THESE PLANS, IS SET ON PILINGS, OR IS INSTALLED AT A MOUNTAIN REGION OR COASTAL HIGH HAZARD SITE SUCH THAT WIND OR OTHER DESIGN PARAMETERS ARE INCREASED, THE DESIGN MUST BE DETERMINED TO BE ADEQUATE FOR ACTUAL SITE CONDITIONS. ALTERATIONS MAY BE REQUIRED TO BRING THE HOME INTO COMPLIANCE WITH THE MORE STRINGENT CONDITIONS.

"Service entrance conductors routed from their point of entrance into the structure, to their point of attachment to the service enclosure a distance horizontally not more than twice the nominal width of the service enclosure and vertically not more than the greater of 5 feet or twice the nominal height of the service enclosure shall be considered to be in compliance with the requirements of 230-70(a) of the current National Electrical Code. Service entrance conductors may be routed in the most direct route or at right angles. Service entrance conductors in excess of these specified limits will not be allowed unless specifically authorized by special permission from the electrical inspector having jurisdiction to accommodate adverse site conditions which would not reasonably allow installation within this criteria."

This home is NOT designed for placement in Coastal High Hazard Areas or Ocean Hazard Areas.

CMH Manufacturing, Inc.	REVISIONS	BY	DATE	ALL MODULAR MODELS
				COVER SHEET 1-0

TYPICAL FASTENING SCHEDULE:

FLOOR FASTENING

RIM JOIST TO JOIST
FLOOR BLOCKING TO JOIST
MULTIPLE JOIST
DECKING TO FLOOR FRAMING

REFERENCE 'CFL' - FLOOR CONSTRUCTION CALCULATIONS OF THE MANUAL.

PER FL-110 OR FL-510.0 IN APPROVED MANUAL
PER FL-100.0 IN APPROVED MANUAL
.131 x 3" NAILS @ 10" O.C., W/ GLUE 80%
PER FL-10 IN APPROVED MANUAL

EXTERIOR WALL FASTENING

LOWER TOP PLATE &
BOTTOM PLATE TO STUD
DOUBLE TOP PLATES
HEADER TO STUDS
HEADER COMPONENTS
STUDS TO SILLS
EXTERIOR SIDING
BOTTOM PLATE TO FLOOR
SIDEWALL TO ENDWALL
WALL WALL TO WALL TOP PLATES
EXTERIOR WALL SHEATHING

REFERENCE 'CEW' - EXTERIOR WALL CONSTRUCTION CALCULATIONS OF THE MANUAL

PER EW-25 IN APPROVED MANUAL DOUBLE STUDS 7/16" x 2-1/2" x 15 GA. STAPLES @ 6" O.C.
PER EW-1 IN APPROVED MANUAL
PER EW-20 CHARTS IN APPROVED MANUAL
PER EW-20 IN APPROVED MANUAL
PER EW-20 IN APPROVED MANUAL
PER THE MANUFACTURER'S SPECIFICATIONS
PER EW-31 IN APPROVED MANUAL
PER EW-30 FOR NON-SHEARWALL OR PER SW-40 FOR SHEARWALL OR PER EW-0.0 IN APPROVED MANUAL
3" x 6" x .036" (20 GA.) GALVANIZED STEEL PLATE W/ (6) .131 x 3" NAILS AT EACH SIDE AT EACH
FOR APA RATED SHEATHING; 7/16" X 1-3/4" X 15 GA. STAPLES AT 6" O.C. AT ALL EDGES & 12" O.C. FIELD. FOR COMPOSITE WALLS, FASTEN PER EW-40. FOR SHEARWALL FASTEN PER SW-40 OR ATTACHED PAGES (IF ATTACHED). ALL OTHER SHEATHING FASTENED PER MANUFACTURER'S INSTALLATION INSTRUCTIONS.

MATING WALL FASTENING

LOWER TOP PLATE TO STUD
BOTTOM PLATE TO STUD
MULTIPLE STUDS
STANDARD COLUMN
DOUBLE TOP PLATES
BOTTOM PLATE TO FLOOR
MATING WALL TO ENDWALL
WALL TO WALL TOP PLATES

REFERENCE 'CMW' - MARRIAGE WALL CALCULATIONS OF THE MANUAL

PER MW-40 IN APPROVED MANUAL
PER MW-40 IN APPROVED MANUAL
7/16" x 2-1/2" x 15 GA. STAPLES OR .131 x 3" NAILS @ 16" O.C. TO EACH MEMBER
PER MW-20 IN APPROVED MANUAL
PER MW-40 IN APPROVED MANUAL
PER MW-31 IN APPROVED MANUAL
PER EW-30 IN APPROVED MANUAL
3" x 6" x .036" (20 GA.) GALVANIZED STEEL PLATE W/ (6) .131 x 3" NAILS AT EACH SIDE AT EACH WALL OR OVERLAPPED PLATE PER EW-0.

INTERIOR WALL FASTENING

BOTTOM PLATE TO STUDS
TOP PLATE TO STUD
DOUBLE STUDS
FLAT HEADER TO STUDS
WALL TO FLOOR
WALL TO WALL
TOP PLATE TO ROOF SYSTEM
GYPSUM TO WALL FRAMING

PER PT-40 IN APPROVED MANUAL
PER PT-40 IN APPROVED MANUAL
7/16" x 2-1/2" x 16 GA. STAPLES @ 16" O.C.
PER PT-20 IN APPROVED MANUAL
PER PT-40 IN APPROVED MANUAL
PER PT-30 IN APPROVED MANUAL
PER PT-40 IN APPROVED MANUAL
PER THE RESIDENTIAL BUILDING CODE TABLES

ROOF FASTENING

CEILING BOARD TO TRUSS
BLOCKING TO TRUSS
TRUSS TO SIDEWALL TOP PLATE
TRUSS TO RIDGE BEAM
TRUSS TO EDGE RAIL
EDGE RAIL TO MATING WALL
TRUSS TO ENDWALL TOP PLATE
ROOF DECKING TO TRUSS
SHINGLE TO ROOF DECKING
OUTLOOKER TO TRUSS

REFERENCE 'CRC' - ROOF CONSTRUCTION CALCULATIONS OF THE MANUAL

FOAM-SEAL 2100 SPRAY ADHESIVE PER THE MANUFACTURER'S SPECIFICATIONS
(2) 7/16" x 2-1/2" x 15 GA. STAPLES DIRECT
PER RC-30 IN APPROVED MANUAL
PER RC-65 IN APPROVED MANUAL
PER MW-31 CHARTS IN APPROVED MANUAL
PER MW-31 CHARTS IN APPROVED MANUAL
PER SW-40 IN APPROVED MANUAL FOR SHEARWALLS AND RC-33.0 FOR NON-SHEARWALLS
PER SW20.0 THRU SW-389E.2 (IF NOT ATTACHED) IN APPROVED MANUAL
PER THE MANUFACTURER'S OR ARMA SPECIFICATIONS
PER RC-70 IN APPROVED MANUAL

INSTALLATION FASTENING

REFERENCE INSTALLATION PAGES PROVIDED IN EACH APPROVAL.

- (CS1) 7/16" APA RATED ROOF DECKING 24/16 SPAN RATING.
- (CS2) 15# MIN. ROOF UNDERLAYMENT; SINGLE LAYER w/ GREATER THAN 4:12 ROOF PITCH; DOUBLE LAYER w/ 4:12 OR LESS
- (CS3) MIN. 20 YEAR SHINGLES.
- (CS4) 1 1/2" WIDE ENGINEERED WOOD BEAM, EACH HALF IN OPEN SPAN AREAS GREATER THAN 48".
- (CS5) ENGINEERED WOOD TRUSSES: COMPONENTS & SPACING PER TRUSS PRINT
* FOR CONNECTION AND SET-UP OF ROOF:
SEE MODULAR SET-UP PAGES ATTACHED TO APPROVAL
- (CS6) CEILING INSULATION, BLOWN OR BATT.(R-VALUE PER RESCHECK)
- (CS7) CONTINUOUS VENTED SOFFIT.
- (CS8) DOUBLE 2x4 TOP PLATE (MIN.).
- (CS9) 2x4 STUDS @ 16" O.C. STUD GRADE SPF (MIN.).
- (CS10) WALL INSULATION (BATT) (R-VALUE PER RESCHECK).
- (CS11) 3/8" OSB SHEATHING WITH WATER RESISTIVE BARRIER BELOW ALL EXT. FINISH MATERIAL. CORROSION-RESISTANT FLASHING REQUIRED AT ALL LOCATIONS AS SHOWN ON APPROVED MANUAL DETAILS
- (CS12) SINGLE 2x4 BOTTOM PLATE SPF #3 (MIN.).
- (CS13) 3/8" (MIN.) GYPSUM WALL BOARD.
- (CS14) FLOOR INSULATION (BATT.) (R-VALUE PER RESCHECK).
- (CS15) MIN. 19/32" RATED DECKING 16" O.C. OR 32/16 SPAN RATING.
- (CS16) MAIN HEAT DUCT. (MAY BE SITE INSTALLED BY OTHERS)
- (CS17) OFF FRAME PER FL-110.0
- (CS18) OFF FRAME PER FL-110.0
- (CS19) 2x3 (MIN.) MARRIAGE WALL STUDS @ 16" O.C.
- (CS20) LISTED BOTTOM BOARD, WHERE OCCURS.
- (CS21) 1/2" SHIM FOR COMPRESSION STRIP.
- (CS22) DOUBLE 2x3 (MIN.) TOP PLATE.
- (CS23) 2x3 (MIN.) BOTTOM PLATE.
- (CS24) 1/2" (MIN.) GYPSUM BOARD CEILING.
- (CS25) WEDGE SUPPORT AT CATHEDRAL CEILING, EACH END OF TRUSS.
- (CS27) CONTINUOUS 2x3 SPF #3 MINIMUM FOR TRUSS TOP RAIL FOR RIDGE CONNECTION
- (CS28) 2x FULL DEPTH BLOCKING 24" O.C. (2) JOIST BAY MIN. ENDWALL LOCATION ONLY.
- (CS29) LAP BOARD, WOOD OR VINYL SIDING, HARDI SIDING, OR EXPOSED SHEATHING FOR ON SITE EXTERIOR FINISH INSTALLATION.

Duct Insulation:

- 1 - Min R-8
- 2 - A VAPOR RETARDER HAVING A MAXIMUM 0.05 PERM IN ACCORDANCE WITH ASTM E96, OR ALUMINUM FOIL WITH A MINIMUM THICKNESS OF 2 MILLS, SHALL BE INSTALLED ON THE EXTERIOR OF THE INSULATION ON THE COOLING SUPPLY DUCT THAT PASS THROUGH UNCONDITIONED SPACE CONDUCTIVE TO CONDENSATION EXCEPT WHERE THE INSULATION IS SPRAY POLYURETHANE FOAM WITH A MAXIMUM WATER VAPOR PERMEANCE OF 3 PERM PER INCH AT THE INSTALLED THICKNESS.

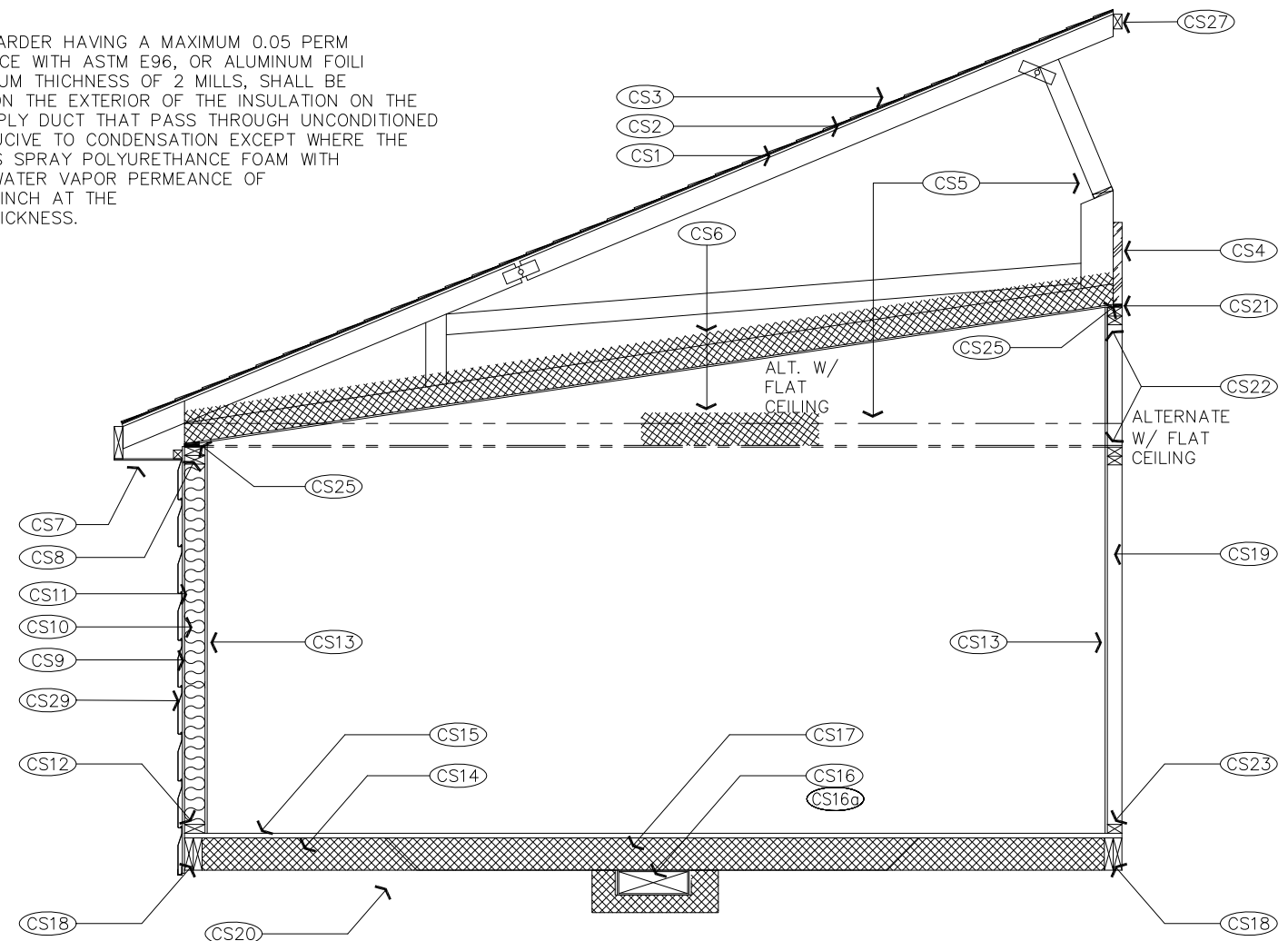

CMH MANUFACTURING, INC	TYPICAL CROSS SECTION & FASTENING SCHEDULE		BRAND:	SERIES:	MODEL NO.:
				NC/SC/DE MODULAR	ALL
			PLANT:	DESCRIPTION:	
			#958	OFF FRAME HINGED ROOF	
DRAWN BY:		DATE DRAWN:	DATE PRINTED:	SHEET:	
DRR		10-21-15	4-25-17	1-0.2	

TYPICAL FASTENING SCHEDULE:

FLOOR FASTENING

RIM JOIST TO JOIST
FLOOR BLOCKING TO JOIST
MULTIPLE JOIST
DECKING TO FLOOR FRAMING

REFERENCE 'CFL' - FLOOR CONSTRUCTION CALCULATIONS OF THE MANUAL.

PER FL-110 OR FL-510.0 IN APPROVED MANUAL
PER FL-100.0 IN APPROVED MANUAL
.131 x 3" NAILS @ 10" O.C., W/ GLUE 80%
PER FL-10 IN APPROVED MANUAL

EXTERIOR WALL FASTENING

LOWER TOP PLATE &
BOTTOM PLATE TO STUD
DOUBLE TOP PLATES
HEADER TO STUDS
HEADER COMPONENTS
STUDS TO SILLS
EXTERIOR SIDING
BOTTOM PLATE TO FLOOR
SIDEWALL TO ENDWALL
WALL WALL TO WALL TOP PLATES
EXTERIOR WALL SHEATHING

REFERENCE 'CEW' - EXTERIOR WALL CONSTRUCTION CALCULATIONS OF THE MANUAL

PER EW-25 IN APPROVED MANUAL DOUBLE STUDS 7/16" x 2-1/2" x 15 GA. STAPLES @ 6" O.C.
PER EW-1 IN APPROVED MANUAL
PER EW-20 CHARTS IN APPROVED MANUAL
PER EW-20 IN APPROVED MANUAL
PER EW-20 IN APPROVED MANUAL
PER THE MANUFACTURER'S SPECIFICATIONS
PER EW-31 IN APPROVED MANUAL
PER EW-30 FOR NON-SHEARWALL OR PER SW-40 FOR SHEARWALL OR PER EW-0.0 IN APPROVED MANUAL
3" x 6" x .036" (20 GA.) GALVANIZED STEEL PLATE W/ (6) .131 x 3" NAILS AT EACH SIDE AT EACH
FOR APA RATED SHEATHING; 7/16" X 1-3/4" X 15 GA. STAPLES AT 6" O.C. AT ALL EDGES & 12" O.C. FIELD. FOR COMPOSITE WALLS, FASTEN PER EW-40. FOR SHEARWALL FASTEN PER SW-40 OR ATTACHED PAGES (IF ATTACHED). ALL OTHER SHEATHING FASTENED PER MANUFACTURER'S INSTALLATION INSTRUCTIONS.

MATING WALL FASTENING

LOWER TOP PLATE TO STUD
BOTTOM PLATE TO STUD
MULTIPLE STUDS
STANDARD COLUMN
DOUBLE TOP PLATES
BOTTOM PLATE TO FLOOR
MATING WALL TO ENDWALL
WALL TO WALL TOP PLATES

REFERENCE 'CMW' - MARRIAGE WALL CALCULATIONS OF THE MANUAL

PER MW-40 IN APPROVED MANUAL
PER MW-40 IN APPROVED MANUAL
7/16" x 2-1/2" x 15 GA. STAPLES OR .131 x 3" NAILS @ 16" O.C. TO EACH MEMBER
PER MW-20 IN APPROVED MANUAL
PER MW-40 IN APPROVED MANUAL
PER MW-31 IN APPROVED MANUAL
PER EW-30 IN APPROVED MANUAL
3" x 6" x .036" (20 GA.) GALVANIZED STEEL PLATE W/ (6) .131 x 3" NAILS AT EACH SIDE AT EACH WALL OR OVERLAPPED PLATE PER EW-0.

INTERIOR WALL FASTENING

BOTTOM PLATE TO STUDS
TOP PLATE TO STUD
DOUBLE STUDS
FLAT HEADER TO STUDS
WALL TO FLOOR
WALL TO WALL
TOP PLATE TO ROOF SYSTEM
GYPSUM TO WALL FRAMING

PER PT-40 IN APPROVED MANUAL
PER PT-40 IN APPROVED MANUAL
7/16" x 2-1/2" x 16 GA. STAPLES @ 16" O.C.
PER PT-20 IN APPROVED MANUAL
PER PT-40 IN APPROVED MANUAL
PER PT-30 IN APPROVED MANUAL
PER PT-40 IN APPROVED MANUAL
PER THE RESIDENTIAL BUILDING CODE TABLES

ROOF FASTENING

CEILING BOARD TO TRUSS
BLOCKING TO TRUSS
TRUSS TO SIDEWALL TOP PLATE
TRUSS TO RIDGE BEAM
TRUSS TO EDGE RAIL
EDGE RAIL TO MATING WALL
TRUSS TO ENDWALL TOP PLATE
ROOF DECKING TO TRUSS
SHINGLE TO ROOF DECKING
OUTLOOKER TO TRUSS

REFERENCE 'CRC' - ROOF CONSTRUCTION CALCULATIONS OF THE MANUAL

FOAM-SEAL 2100 SPRAY ADHESIVE PER THE MANUFACTURER'S SPECIFICATIONS
(2) 7/16" x 2-1/2" x 15 GA. STAPLES DIRECT
PER RC-30 IN APPROVED MANUAL
PER RC-65 IN APPROVED MANUAL
PER MW-31 CHARTS IN APPROVED MANUAL
PER MW-31 CHARTS IN APPROVED MANUAL
PER SW-40 IN APPROVED MANUAL FOR SHEARWALLS AND RC-33.0 FOR NON-SHEARWALLS
PER SW20.0 THRU SW-389E.2 (IF NOT ATTACHED) IN APPROVED MANUAL
PER THE MANUFACTURER'S OR ARMA SPECIFICATIONS
PER RC-70 IN APPROVED MANUAL

INSTALLATION FASTENING

REFERENCE INSTALLATION PAGES PROVIDED IN EACH APPROVAL.

- (CS1) 7/16" APA RATED ROOF DECKING 24/16 SPAN RATING.
- (CS2) 15# MIN. ROOF UNDERLAYMENT; SINGLE LAYER w/ GREATER THAN 4:12 ROOF PITCH; DOUBLE LAYER w/ 4:12 OR LESS
- (CS3) MIN. 20 YEAR SHINGLES.
- (CS4) 1 1/2" WIDE ENGINEERED WOOD BEAM, EACH HALF IN OPEN SPAN AREAS GREATER THAN 48".
- (CS5) ENGINEERED WOOD TRUSSES: COMPONENTS & SPACING PER TRUSS PRINT
* FOR CONNECTION AND SET-UP OF ROOF:
SEE MODULAR SET-UP PAGES ATTACHED TO APPROVAL.

- (CS16) MAIN HEAT DUCT. (MAY BE SITE INSTALLED BY OTHERS)
- (CS17) ON-FRAME PER FL-510 IN APPROVED MANUAL

- (CS18) ON-FRAME PER FL-510 IN APPROVED MANUAL

- (CS19) 2x3 (MIN.) MARRIAGE WALL STUDS @ 16" O.C.

- (CS20) LISTED BOTTOM BOARD, WHERE OCCURS.

- (CS21) 1/2" SHIM FOR COMPRESSION STRIP.

- (CS22) DOUBLE 2x3 (MIN.) TOP PLATE.

- (CS23) 2x3 (MIN.) BOTTOM PLATE.

- (CS24) 1/2" (MIN.) GYPSUM BOARD CEILING.

- (CS25) WEDGE SUPPORT AT CATHEDRAL CEILING, EACH END OF TRUSS.

- (CS26) PER FL-510 IN APPROVED MANUAL

- (CS27) CONTINUOUS 2x3 SPF #3 MINIMUM FOR TRUSS TOP RAIL FOR RIDGE CONNECTION

- (CS29) LAP BOARD, WOOD OR VINYL SIDING, HARDI SIDING, OR EXPOSED SHEATHING FOR ON SITE EXTERIOR FINISH INSTALLATION.

- (CS6) CEILING INSULATION, BLOWN OR BATT.(R-VALUE PER RESCHECK)

- (CS7) CONTINUOUS VENTED SOFFIT.

- (CS8) DOUBLE 2x4 TOP PLATE (MIN.).

- (CS9) 2x4 STUDS @ 16" O.C. STUD GRADE SPF (MIN.).

- (CS10) WALL INSULATION (BATT) (R-VALUE PER RESCHECK).

- (CS11) 3/8" OSB SHEATHING WITH WATER RESISTIVE BARRIER BELOW ALL EXT. FINISH MATERIAL. CORROSION-RESISTANT FLASHING REQUIRED AT ALL LOCATIONS AS SHOWN ON APPROVED MANUAL DETAILS

- (CS12) SINGLE 2x4 BOTTOM PLATE SPF #3 (MIN.).

- (CS13) 3/8" (MIN.) GYPSUM WALL BOARD.

- (CS14) FLOOR INSULATION (BATT, OR BLANKET) (R-VALUE PER RESCHECK).

- (CS15) MIN. 19/32" RATED DECKING 16" O.C. OR 32/16 SPAN RATING.

- (CS16a) Duct Insulation:

- 1 - Min R-8
- 2 - A VAPOR RETARDER HAVING A MAXIMUM 0.05 PERM IN ACCORDANCE WITH ASTM E96, OR ALUMINUM FOIL WITH A MINIMUM THICKNESS OF 2 MILLS, SHALL BE INSTALLED ON THE EXTERIOR OF THE INSULATION ON THE COOLING SUPPLY DUCT THAT PASS THROUGH UNCONDITIONED SPACE CONDUCIVE TO CONDENSATION EXCEPT WHERE THE INSULATION IS SPRAY POLYURETHANE FOAM WITH A MAXIMUM WATER VAPOR PERMEANCE OF 3 PERM PER INCH AT THE INSTALLED THICKNESS.

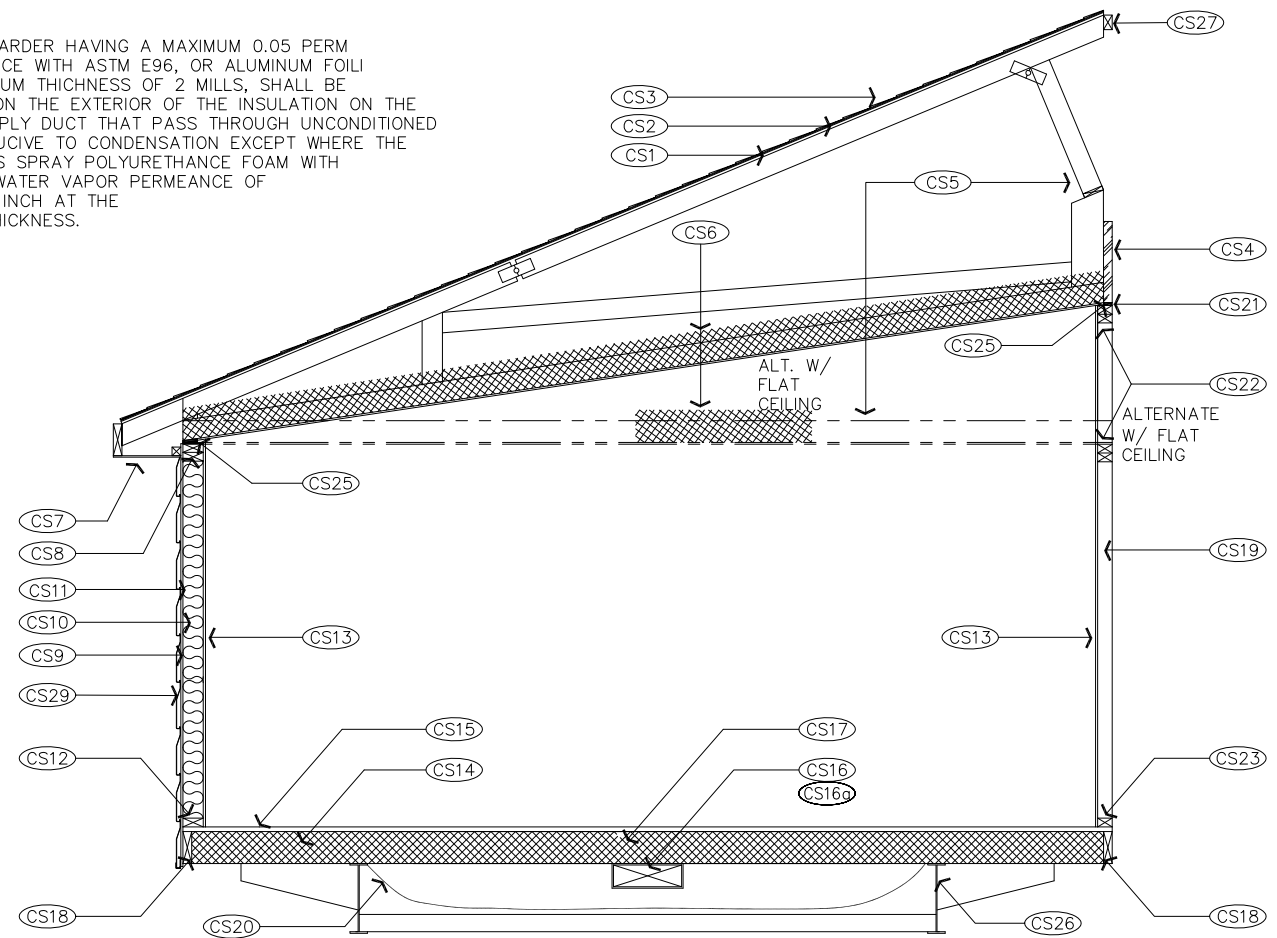

CMH MANUFACTURING, INC	TYPICAL CROSS SECTION & FASTENING SCHEDULE		BRAND:	SERIES:	MODEL NO.:
				NC/SC/DE MODULAR	ALL
			PLANT:	DESCRIPTION:	
			#958	ON FRAME HINGED ROOF	
		DRAWN BY:	DATE DRAWN:	DATE PRINTED:	SHEET:
		DRR	10-21-15	12-13-16	1-0.2

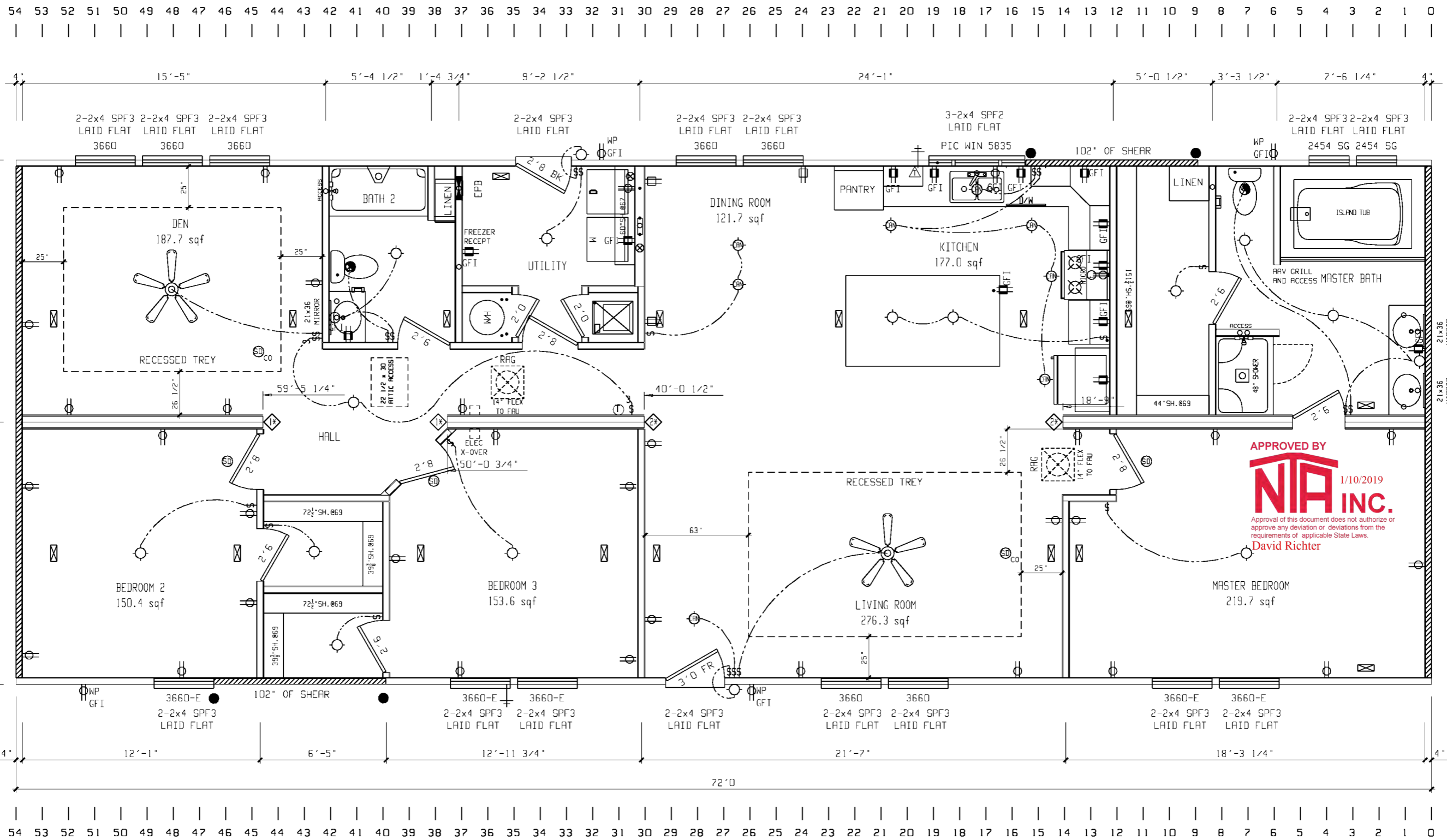

2x6 Exterior Walls Required with Climate Zone 5 / R-19
 Std Roof Truss - 24\"/>

INSULATION DONE PER THE NORTH CAROLINA 2018 PRESCRIPTIVE METHOD
 C23: R=38 CEILING R=15 WALLS R=22 FLOOR
 C24: R=38 CEILING R=15 WALLS R=22 FLOOR
 C25: R=38 CEILING R=19 WALLS R=30 FLOOR
 U = 0.35 / SHGC = 0.28

APPROVED BY
NIA INC.
 1/10/2019
 Approval of this document does not authorize or approve any deviation or deviations from the requirements of applicable State Laws.
 David Richter

320"EW/ 94"SW 90MPH
 195PLF EFFECTIVE LENGTHS
 BASED ON SW-31.10. .1a.C.17. .78.1-2
 ENGINEERED METHOD.
 UNBLOCKED DIAPHRAGM SW-20-389B.1

320"EW/ 94"SW 100MPH
 241PLF EFFECTIVE LENGTHS
 BASED ON SW-31.10. .1a.E.17. .78.1-2
 ENGINEERED METHOD.
 UNBLOCKED DIAPHRAGM SW-20-389B.1

320"EW/102"SW 120MPH
 320PLF EFFECTIVE LENGTHS
 BASED ON SW-31.10. .1a.L.17. .78.1-2
 ENGINEERED METHOD.
 UNBLOCKED DIAPHRAGM SW-20-389B.1

RIDGE BEAM PER: RC-60.3.R.G.M. .20
 COLUMNS PER: MW-20.3.R.G.M.48.20
 2x4 SIDEWALL HEADERS PER:
 EW-20.3.R.G.C.22.20 (90MPH)
 EW-20.3.R.G.E.22.20 (100MPH)
 EW-20.3.R.G.I.22.20 (120MPH)

2x6 SIDEWALL HEADERS PER:
 EW-20.3.R.G.C.22.20-1 (90MPH)
 EW-20.3.R.G.E.22.20-1 (100MPH)
 EW-20.3.R.G.I.22.20-1 (120MPH)

RETURN AIR REQUIREMENTS		INDICATES FREE END SHEAR WITH BLOCKING
① 20"x16" GRILL REQUIRED	② 4"x10" GRILL W/ 2 1/2" DOOR UNDERCUT	
③ DOOR(S) MUST BE UNDERCUT 2 1/2" MIN.	④ 4"x24" OR 6"x14" GRILL REQUIRED	

BRAND	SCHULT	SERIES	MD28
CLAYTON HOME BUILDING GROUP			

REVISIONS	BY	DATE
	RXP	08/29/17

GENERAL NOTES
CEILING HEIGHT = 108.0
FLOOR FRAMING SPACING = 16
TOTAL WINDOW SOFT = ENTER TOTAL CALCULATED

DRAWING TITLE	MASTER PLAN <i>Glamour M. Bath</i>
---------------	--

MODEL NAME	5531-28W-3BR	SO. FT.	1920
PLANT	958	DESCRIPTION	28X72 3BR-2BA
DRAWN BY	GCK	ORIG. DATE	11/08/2017
		DATE PRINTED	01/09/2019
		MODEL NO.	5531-28W-3BR
		SHEET NO.	1-1

APPROVED BY
NIA INC. 1/10/2019
Approval of this document does not authorize or approve any deviation or deviations from the requirements of applicable State Laws.
 David Richter

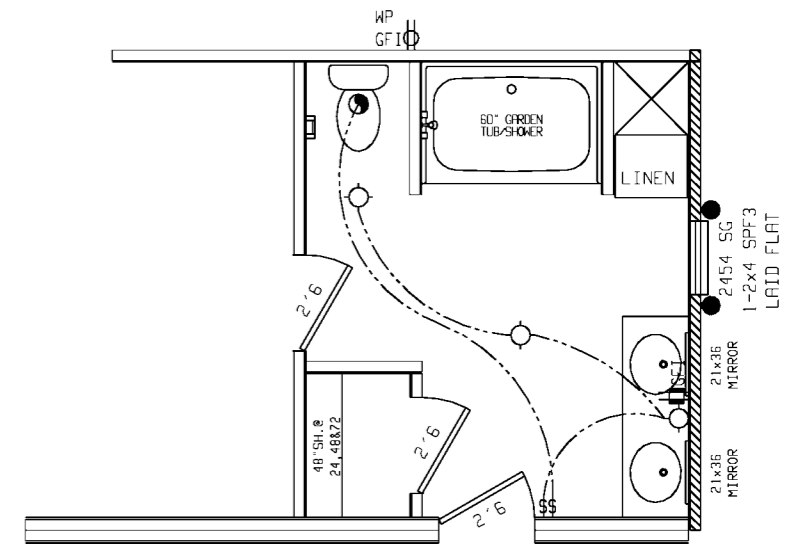

DESIGN LOADS WIND-ROOF PSF	RETURN AIR REQUIREMENTS	INDICATES REQUIRED NUMBER OF STUDS IN COLUMN
90-30	① 20"x16" GRILL REQUIRED	④ THE * SPECIFIES THAT THERE CAN BE NO HOLES IN STUDS IN COLUMNS
100-30	② 4"x10" GRILL W/ 2 1/2" DOOR UNDERCUT	
120-30	③ DOOR(S) MUST BE UNDERCUT 2 1/2" MIN.	
130-30	④ 4"x24" OR 6"x14" GRILL REQUIRED	

BRAND SCHULT	SERIES MD28
CLAYTON HOME BUILDING GROUP	

REVISIONS	BY	DATE

GENERAL NOTES
CEILING HEIGHT = 108.0

DRAWING TITLE MASTER PLAN <i>Std. M.Bath</i>

MODEL NAME 5531-28W-3BR		SO. FT. 1920
PLANT 958	DESCRIPTION 28X72 3BR-2BA	MODEL NO. 5531-28W-3BR
DRAWN BY GCK	ORIG. DATE 11/08/2017	DATE PRINTED 01/08/2019
SHEET NO. 1-2		

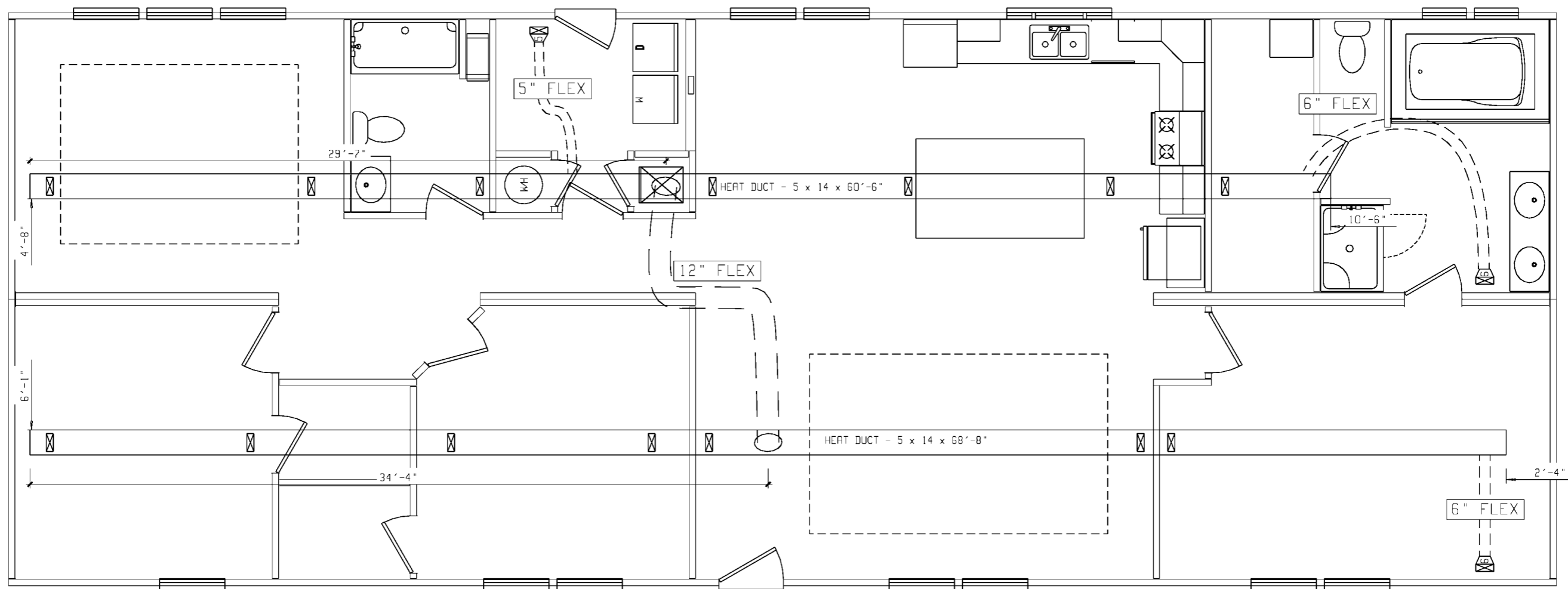

A-SECTION HITCH END

B-SECTION HITCH END

APPROVED BY
NIA INC. 1/10/2019
 Approval of this document does not authorize or approve any deviation or deviations from the requirements of applicable State Laws.
 David Richter

BRAND	SCHULT	SERIES	MD28
CLAYTON HOME BUILDING GROUP			

REVISIONS	BY	DATE

GENERAL NOTES

DRAWING TITLE	INLINE LOOP HVAC
---------------	-------------------------

MODEL NAME	5531-28W-3BR		SQ. FT.	1920
PLANT	DESCRIPTION	MODEL NO.		
958	28X72 3BR-2BA	5531-28W-3BR		
DRAWN BY	ORIG. DATE	DATE PRINTED	SHEET NO.	
GCK	11/08/2017	01/09/2019	4-3	

NOTE
 DASHED LINES REPRESENT BELOW
 FLOOR DWV PIPE TO BE FIELD INSTALLED
 BY OTHERS. LAYOUT MAY VARY
 DUE TO SITE CONDITIONS.
 BUILDER IS RESPONSIBLE TO
 ASSURE THAT FINAL SYSTEM
 CONFORMS TO ALL APPLICABLE CODES.

PIPING AND FITTING MATERIAL TYPE TO BE:
 ABS (ACRYLONITRILE-BUTADIENE-STYRENE)
 OR PVC (POLYVINYL CHLORIDE)

PIPE LEGEND	
	1 1/2"
	2"
	3"

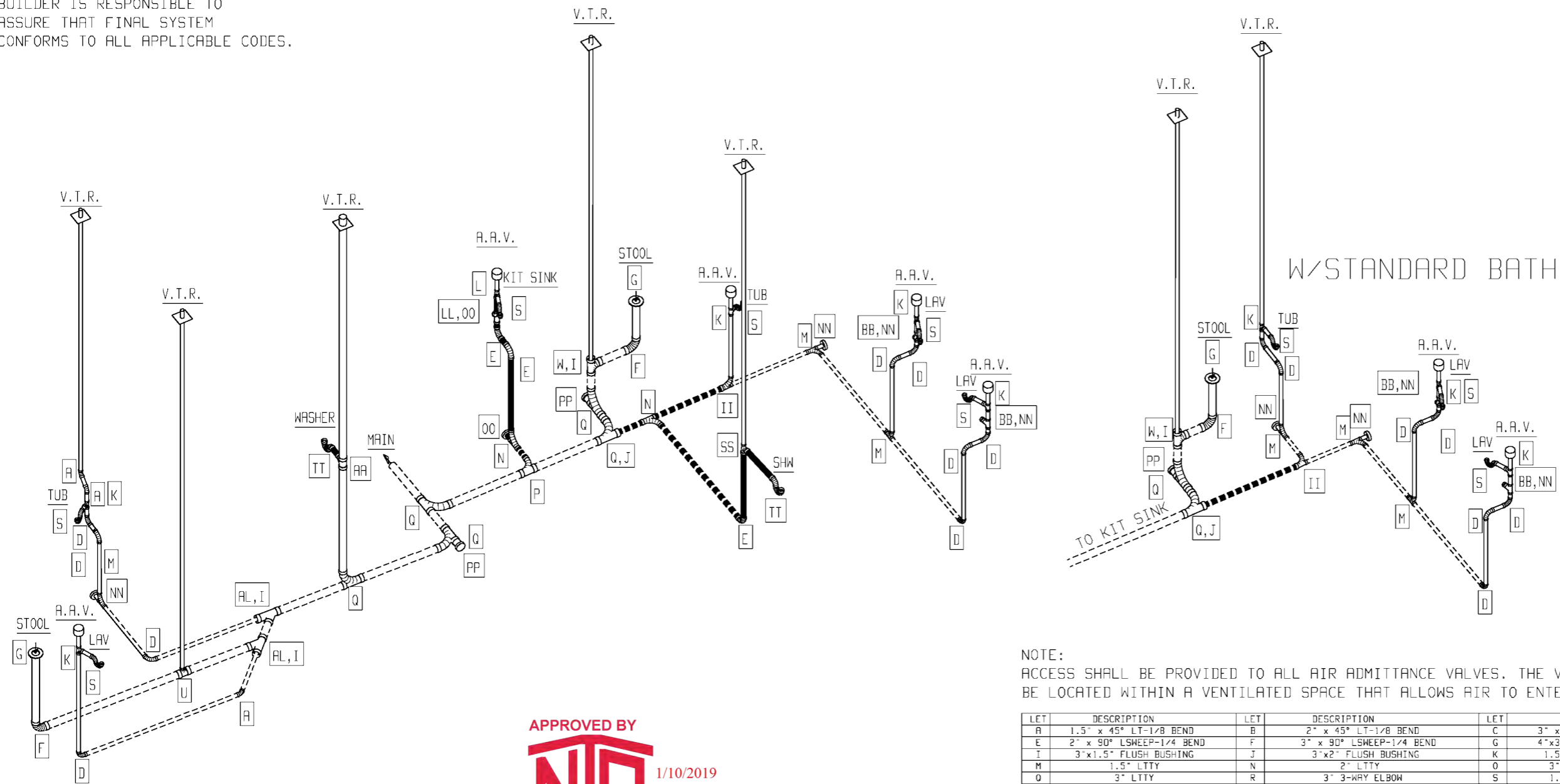

STANDARD SHIP LOOSE	
A	1
AL, I	2
D	3
E	1
F	2
II	1
M	3
N	2
NN	2
OO	1
P	1
PP	2
Q	4
Q, J	1
U	1
W, I	1
1.5" PIPE	30 FT
2" PIPE	10 FT
3" PIPE	45 FT

NOTE:
 ACCESS SHALL BE PROVIDED TO ALL AIR ADMITTANCE VALVES. THE VALVE SHALL
 BE LOCATED WITHIN A VENTILATED SPACE THAT ALLOWS AIR TO ENTER THE VALVE

APPROVED BY

 1/10/2019
 Approval of this document does not authorize or
 approve any deviation or deviations from the
 requirements of applicable State Laws.
 David Richter

LET	DESCRIPTION	LET	DESCRIPTION	LET	DESCRIPTION	LET	DESCRIPTION
A	1.5" x 45° LT-1/8 BEND	B	2" x 45° LT-1/8 BEND	C	3" x 45° LT-1/8 BEND	D	1.5" x 90° LONG SWEEP-1/4 BEND
E	2" x 90° LSWEPT-1/4 BEND	F	3" x 90° LSWEPT-1/4 BEND	G	4"x3" CLOSET FLANGE	H	2"x1.5" FLUSH BUSHING
I	3"x1.5" FLUSH BUSHING	J	3"x2" FLUSH BUSHING	K	1.5" SANITARY TEE	L	2"x1.5"x1.5" SAN TEE
M	1.5" LTTY	N	2" LTTY	O	3"x3"x1.5" LTTY	P	3"x3"x2" LTTY
Q	3" LTTY	R	3" 3-WAY ELBOW	S	1.5"x1.5" P-TRAP	T	3"x3"x1.5"x1.5" DBL SAN TEE
U	3"x3"x1.5" SAN TEE	V	1.5" x 90° LONG SWEEP STREET	W	3" SANITARY TEE	X	3"x3"x1.5" WYE
Y	2" 3-WAY ELBOW	Z	2"x2"x1.5" LTTY	AA	3"x3"x2" SAN TEE	BB	1.5" x 45° WYE
CC	2" x 90° LSWEPT STREET	DD	1.5" x 45° 1/8 BEND STREET	EE	1.5" COUPLING	FF	3" COUPLING
GG	1.5" P-TRAP @ WASHER	HH	1.5" SAN TEE STREET	II	2"x1.5"x1.5" LTTY	JJ	2"x1.5"x2" LTTY
KK	2" x 1/4 BEND STREET	LL	2" x 45° WYE	MM	3" DBL SAN TEE	NN	1.5" C.O. W/PLUG
OO	2" C.O. W/PLUG	PP	3" C.O. W/PLUG	QQ	2"x2"x1.5" WYE REDUCING	RR	1.5" 1/4 BEND
SS	2"x1.5"x2" SAN TEE	TT	2" P-TRAP	UU	2" x 45° 1/8 BEND STREET	VV	2" COUPLING
WW	3" x 45° 1/8 BEND STREET	XX	2" SANITARY TEE	YY	4" CLOSET FLANGE	ZZ	4" COUPLING
AB	1.5" CONT WASTE	AC	1.5" x 22 1/2° ELBOW STREET	AD	2" x 22 1/2° ELBOW STREET	AE	3"x3"x2"x2" DBL SAN TEE
AF	2"x1.5"x1.5" SAN TEE STREET	AG	2"x1.5"x1.5" 3-WAY ELBOW	AH	3" x 22 1/2° 1/16 BEND ELBOW	AI	1.5" 3-WAY ELBOW
AJ	2" x 22 1/2° 1/16 BEND ELBOW	AK	4"x3" CLOSET BEND STR (CUT DOWN 1.5")	AL	3"x3"x3" WYE	AM	3" 1/4 BEND
AN	2"x3" PIPE INCREASER	AO	3" x 3" x 2" WYE	AP	2" 1/4 BEND	AQ	2"x2"x2"x2" DBL SAN TEE
AR	1.5"x3" PIPE INCREASER	AS	1.5"x1.5"x1.5"x1.5" DBL SAN TEE	AT	3" DOUBLE FIXTURE TEE	AU	2"x2"x1.5"x1.5" DBL SAN TEE
AV	3"x3"x2"x2" SAN TEE (SI) LEFT	AW	3"x3"x3"x1.5" SAN TEE (SI) LEFT	AX	3"x3"x3"x2" SAN TEE (SI) LEFT	AY	3"x3"x2"x2" SAN TEE (SI) RIGHT
AZ	3"x3"x3"x1.5" SAN TEE (SI) RIGHT	BA	3"x3"x3"x2" SAN TEE (SI) RIGHT	BC	3"x3"x3"x2"x2" SAN TEE DBL(SI)	BD	3"x3"x3"x1.5"x1.5" SAN T DBL(SI)
BE	1.5"x2" PIPE INCREASER	BF	3"x3"x1.5" 90° LSWEPT LOW HEEL INLET	BG	3"x3"x2" 90° LSWEPT LOW HEEL INLET	BH	1.5" x 22 1/2° 1/16 BEND ELBOW
BI	4"x3" CLOSET BEND STREET	BJ		BK		BL	

BRAND SCHULT	SERIES MD28	REVISIONS	BY	DATE	GENERAL NOTES	DRAWING TITLE DWV SCHEMATIC	MODEL NAME 5531-28W-3BR	SO. FT. 1920
CLAYTON HOME BUILDING GROUP							PLANT 958	DESCRIPTION 28X72 3BR-2BA
							MODEL NO. 5531-28W-3BR	
							DRAWN BY GCK	ORIG. DATE 11/08/2017
							DATE PRINTED 01/08/2019	SHEET NO. 8-1

PIPING AND FITTING MATERIAL TYPE TO BE:
PEX TYPE BY QUEST, CPVC OR COPPER

PRESSURE RANGE 40-49 PSI
60' DEVELOPED LENGTH



COLD WATER SUPPLY PLUMBING

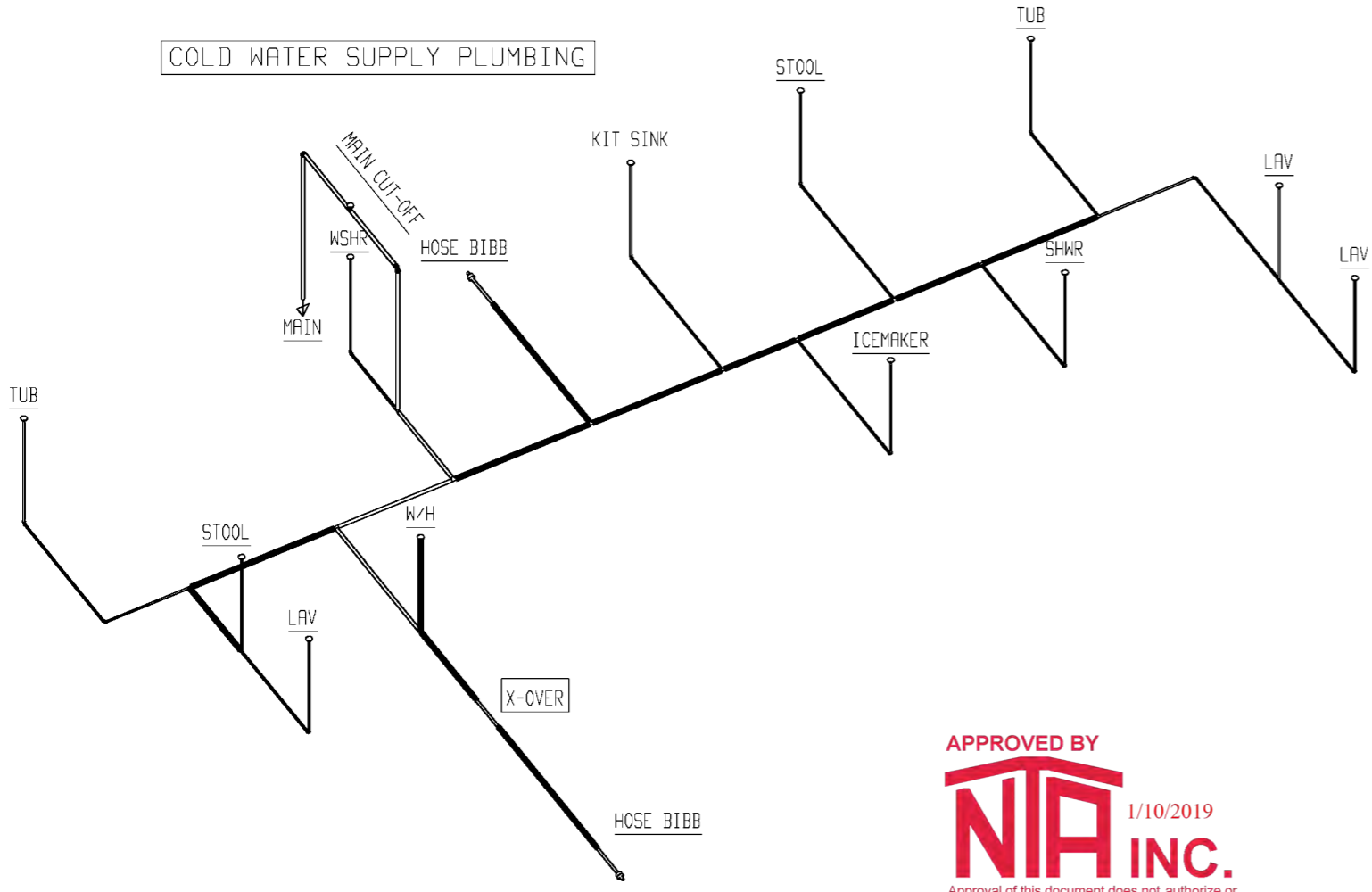

APPROVED BY
NIA INC.
1/10/2019
Approval of this document does not authorize or approve any deviation or deviations from the requirements of applicable State Laws.
David Richter

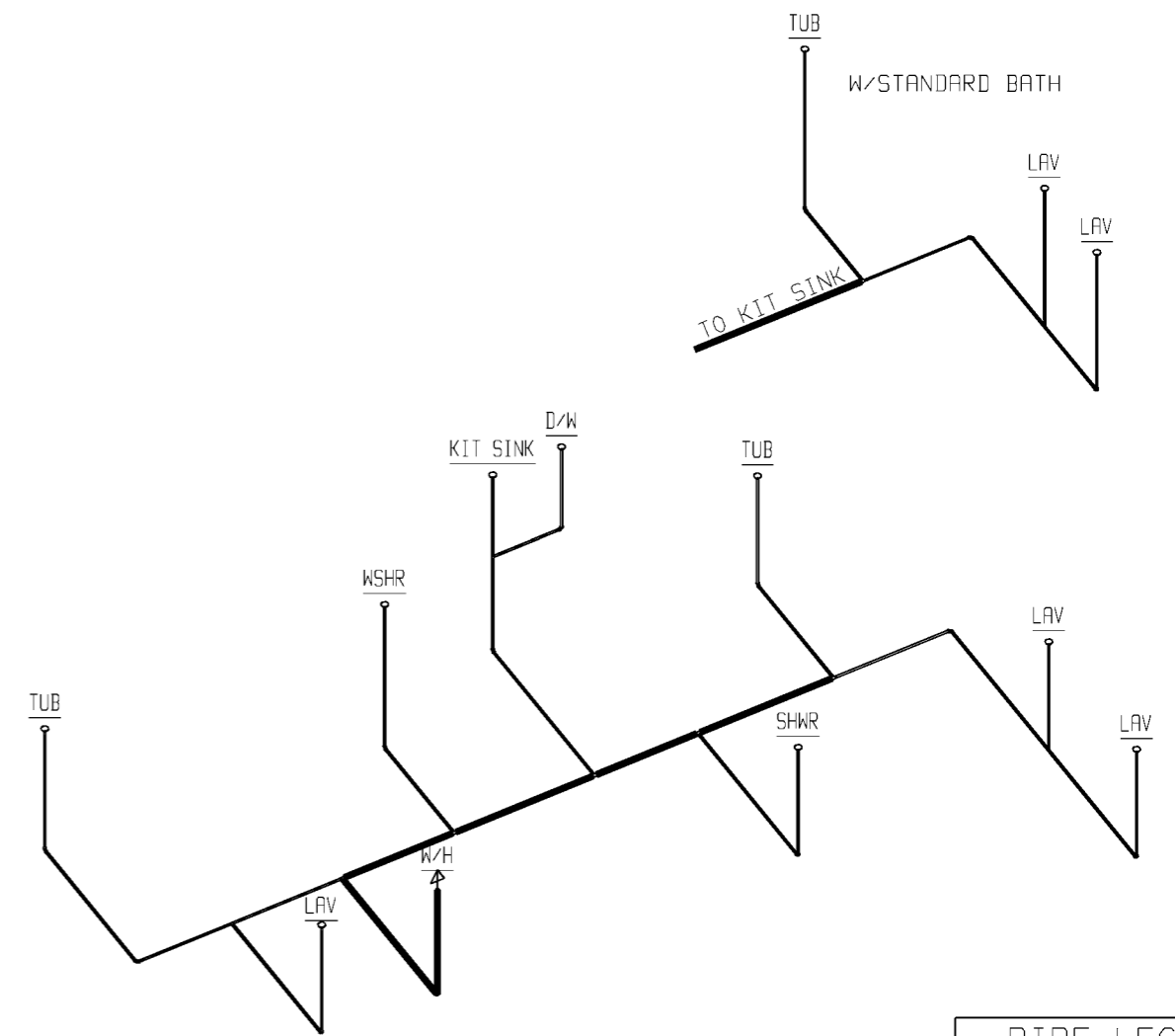

HOT WATER SUPPLY PLUMBING

PIPE LEGEND	
	1"
	3/4"
	1/2"

BRAND SCHULT	SERIES MD28
CLAYTON HOME BUILDING GROUP	

REVISIONS	BY	DATE

GENERAL NOTES
HOSE BIBBS PER SPECS

DRAWING TITLE SUPPLY PLUMBING

MODEL NAME 5531-28W-3BR		SQ. FT. 1920	
PLANT 958	DESCRIPTION 28X72 3BR-2BA	MODEL NO. 5531-28W-3BR	
DRAWN BY GCK	ORIG. DATE 11/08/2017	DATE PRINTED 01/10/2019	SHEET NO. 9-1

APPROVED BY
NIA INC. 1/10/2019
 Approval of this document does not authorize or approve any deviation or deviations from the requirements of applicable State Laws.
 David Richter

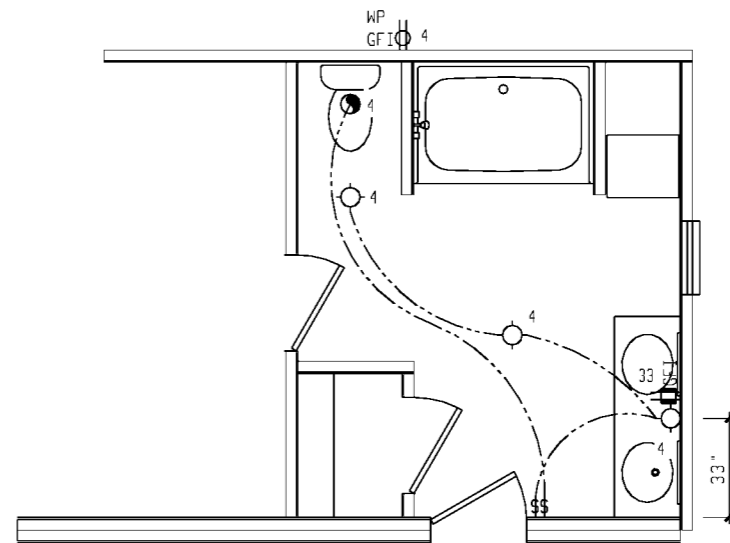

NOTE: ALL FAMILY, DINING, LIVING, PARLOR, LIBRARIES, DENS, BEDROOMS, SUNROOMS, RECREATION ROOMS, CLOSETS, HALLWAYS OR SIMILAR ROOMS OR SPACES SHALL BE PROTECTED BY A LISTED ARC-FAULT CIRCUIT INTERRUPTER IN ACCORDANCE WITH SECTION 210.12 OF THE NEC.

ELECTRICAL SCHEDULE

CIR. NO.	DESCRIPTION	BRK. AMP.	VOLTS	COPR. WIRE	CIR. NO.	DESCRIPTION	BRK. AMP.	VOLTS	COPR. WIRE	CIR. NO.	DESCRIPTION	BRK. AMP.	VOLTS	COPR. WIRE	CIR. NO.	DESCRIPTION	BRK. AMP.	VOLTS	COPR. WIRE	CIR. NO.	DESCRIPTION	BRK. AMP.	VOLTS	COPR. WIRE	CIR. NO.	DESCRIPTION	BRK. AMP.	VOLTS	COPR. WIRE															
1	PORTABLE APPLIANCES	20	120	12	5	GEN. LIGHTING/RECEPT.	15	120	14	8	DRYER RECEP.T.	30	240	10	12	ELECTRIC FURNACE	CIRCUITS VARY, SEE DAP/IA PAGE PLN-3.5 FOR HUD, PLN-1.5 FOR MOD		15	120	14	19	GEN. LIGHTING/RECEPT.	15	120	14	24	ELECT. BUILT-IN OVEN	20	240	12/3	28	GEN. LIGHTING/RECEPT.	15	120	14	32	SMOKE ALARMS	15	120	14			
2	PORTABLE APPLIANCES	20	120	12	6	ELEC. WATER HEATER	CIRCUITS VARY, SEE DAP/IA PAGE PLN-3.1 FOR HUD, PLN-1.1 FOR MOD		9	OPT. DISHWASHER	15	120	14	16	FREEZER	20	120	12	17	OPT. WHIRLPOOL	20	120	12	20	GEN. LIGHTING/RECEPT.	15	120	14	25	GEN. LIGHTING/RECEPT.	15	120	14	29	GEN. LIGHTING/RECEPT.	15	120	14	33	BATH GFI (MOD ONLY)	20	120	12	
3	PORTABLE APPLIANCES	20	120	12	7	WASHER RECEP.T.	20	120	12	10	ELECT. RANGE/CKTOP	40	240	8	13	GEN. LIGHTING/RECEPT.	15	120	14	14	OPT. COOLER BOX	15	120	14	18	GEN. LIGHTING/RECEPT.	15	120	14	21	GEN. LIGHTING/RECEPT.	15	120	14	30	GEN. LIGHTING/RECEPT.	15	120	14	34	GEN. LIGHTING/RECEPT.	20	120	12
4	GEN. LIGHTING/RECEPT.	15	120	14	11	GAS FURNACE	15	120	14	11	GAS FURNACE	15	120	14	14	OPT. COOLER BOX	15	120	14	18	GEN. LIGHTING/RECEPT.	15	120	14	22	OPT. MICROWAVE	20	120	12/2	27	GEN. LIGHTING/RECEPT.	15	120	14	31	SITE INSTALLED HEAT PUMP	40	240	8/3	39	REFRIGERATOR	20	120	12

BRAND SCHULT	SERIES MD28	REVISIONS	BY	DATE	GENERAL NOTES LOCK-OUT BREAKER ON CIRCUIT #6	DRAWING TITLE ELECTRICAL PLAN Std. M.Bath	MODEL NAME 5531-28W-3BR	SQ. FT. 1920		
CLAYTON HOME BUILDING GROUP							PLANT 958	DESCRIPTION 28X72 3BR-2BA	MODEL NO. 5531-28W-3BR	
							DRAWN BY GCK	ORIG. DATE 11/08/2017	DATE PRINTED 01/08/2019	SHEET NO. 11-2

1920 SQ. FT. ATTIC AREA
 921 SQ. IN. REQUIRED
 VENTED SOFFIT - 7.38 SQ. IN. VENT/FT
 66 FT RIDGE CAP/VENT-18.00 SQ. IN. VENT/FT
 1062 SQ. IN. PROVIDED FOR SOFFIT
 1188 SQ. IN. PROVIDED FOR RIDGE VENT

6:12

VINYL LAP SIDING/SHINGLE ROOF



FRONT ELEVATION

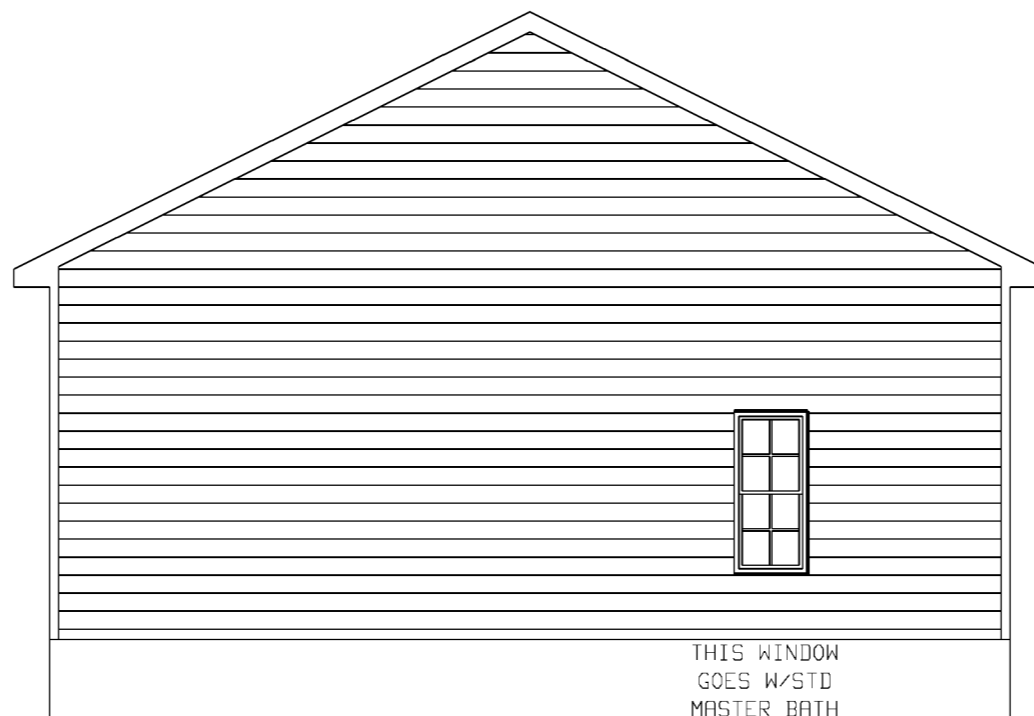

THIS WINDOW
 GOES W/STD
 MASTER BATH

RIGHT SIDE ELEVATION

APPROVED BY
NIA INC. 1/10/2019
 Approval of this document does not authorize or
 approve any deviation or deviations from the
 requirements of applicable State Laws.
 David Richter

BRAND SCHULT	SERIES MD28	REVISIONS	BY	DATE	GENERAL NOTES	DRAWING TITLE EXTERIOR ELEVATION FRONT & RIGHT SIDE	MODEL NAME 5531-28W-3BR	SQ. FT. 1920		
CLAYTON HOME BUILDING GROUP							PLANT 958	DESCRIPTION 28X72 3BR-2BA	MODEL NO. 5531-28W-3BR	
							DRAWN BY GCK	ORIG. DATE 11/08/2017	DATE PRINTED 01/09/2019	SHEET NO. 20-1

IMPORTANT:
 THIS FOUNDATION DRAWING IS MODEL SPECIFIC AND ILLUSTRATES THE BASIC LAYOUT ONLY.
 FOR FOUNDATION CONSTRUCTION, FASTENING AND SECUREMENT DETAILS YOU MUST REFER
 TO THE ATTACHED FOUNDATION MANUAL INCLUDED WITH THIS HOME.

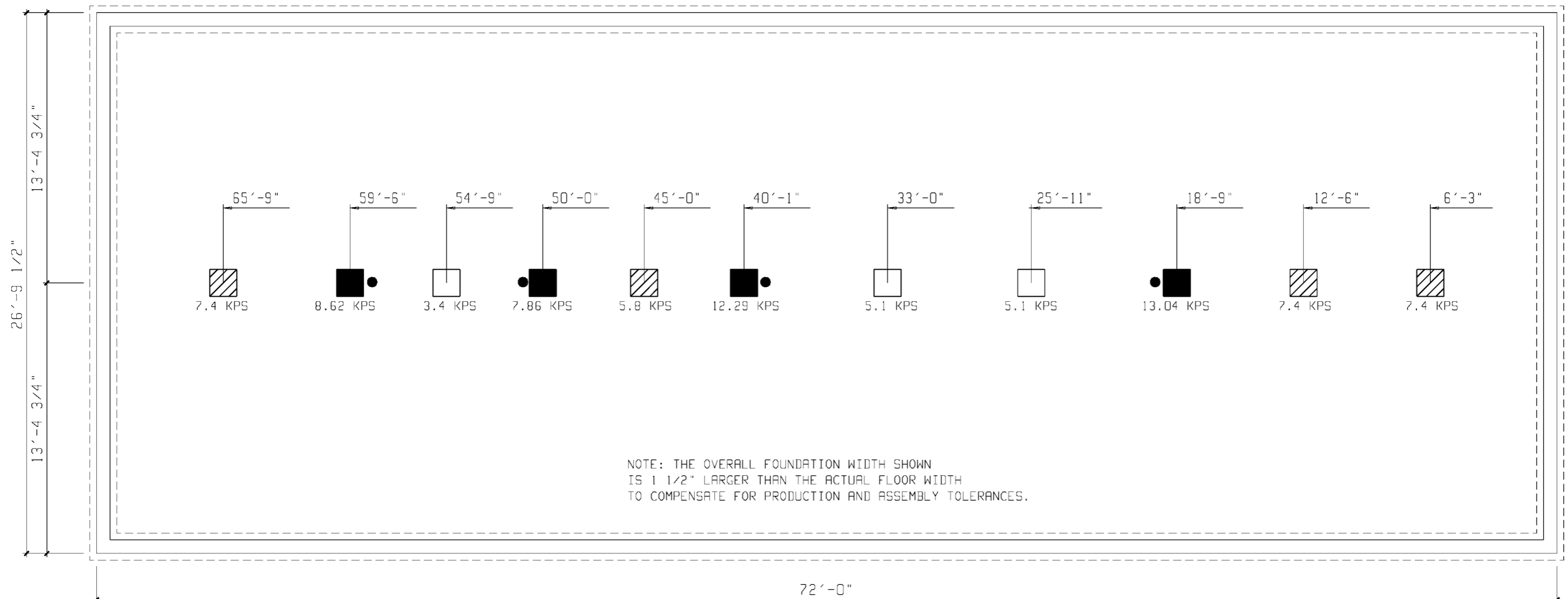

NOTE: THE OVERALL FOUNDATION WIDTH SHOWN IS 1 1/2" LARGER THAN THE ACTUAL FLOOR WIDTH TO COMPENSATE FOR PRODUCTION AND ASSEMBLY TOLERANCES.

APPROVED BY
NIA INC. 1/10/2019
 Approval of this document does not authorize or approve any deviation or deviations from the requirements of applicable State Laws.
 David Richter

2x6 EXTERIOR WALLS BUILT IN WHEN OPTIONED

● NOTES MARRIAGE WALL TIE DOWNS PER TABLE M AND DETAIL D6 IN THE FOUNDATION PACKAGE

PIER LEGEND	
	= SUPPORT AT MATING COLUMN
	= SUPPORT UNDER MATING WALL
	= SUPPORT UNDER MATING OPENING
	= SUPPORT AT PORCH/RECESSED ENTRY
	= SUPPORT UNDER MAIN I-BEAM
	= SUPPORT UNDER PERIMETER WALL
	= SUPPORT AT CROSS I-BEAM BASEMENT

SERVICE ENTRANCE LEGEND	
	= ELECTRICAL DROP
	= WATER INLET
	= DWV PLUMBING DROP
	= GAS INLET

NOTE:
 ALL LOCATIONS ARE APPROXIMATE

CRAWLSPACE VENTILATION VENTILATION IS BASED ON 144 SQ. IN. OF VENT FOR EVERY 150 SQ. FT. OF CRAWLSPACE AREA WITH APPROVED VAPOR RETARDER MATERIAL. ONE SUCH VENT MUST BE WITHIN 3 FT. OF EACH CORNER	1920 SQ. FT. OF CRAWLSPACE AREA 1844 SQ. IN. OF VENT REQUIRED 36 VENTS NEEDED @ 52 SQ. IN. EACH 1872 SQ. IN. VENTILATION INSTALLED MINIMUM	CRAWL SPACE 18" MIN CLEARANCE BELOW BOTTOM OF FLOOR JOIST. GROUND TO BE COVERED WITH APPROVED VAPOR RETARDER MATERIAL.	INSTALL SWITCHED LIGHT AND GFCI RECEPT AT CRAWL SPACE ENTRANCE FOR SERVICE OF MECHANICAL EQUIPMENT PER NEC - 210-70 (C)	NOTE: MASONRY UNITS FOR STAND ALONE PIERS SHALL BE LAID IN TYPE "M" OR "S" MORTAR OR SHALL BE COVERED WITH SURFACE BONDING CEMENT COMPLYING WITH ASTM C 887 WHEN ACCEPTABLE TO LOCAL BUILDING AUTHORITY. SURFACE BONDING CEMENT SHALL BE APPLIED IN STRICT COMPLIANCE OF MANUFACTURERS INSTRUCTIONS. BOTTOM COURSE SHALL BE LAID IN TYPES "M" OR "S" MORTAR OR BONDING MORTAR (CEMENT).
--	---	--	---	---

BRAND SCHULT	SERIES MD28	REVISIONS	BY	DATE	GENERAL NOTES SEE INSTALLATION MANUAL FOR FOUNDATION GENERAL NOTES & TIE-DOWN REQUIREMENTS FOUNDATION VENT LOCATIONS ARE SHOWN TYPICAL & ARE SUBJECT TO CHANGE DUE TO PIER LOCATION, CHASSIS MEMBERS & EXTERIOR DECK INSTALLATION	DRAWING TITLE 20130 PSF FOUNDATION	MODEL NAME 5531-28W-3BR	SQ. FT. 1920		
CLAYTON HOME BUILDING GROUP							PLANT 958	DESCRIPTION 28X72 3BR-2BA	MODEL NO. 5531-28W-3BR	
							DRAWN BY GCK	ORIG. DATE 11/08/2017	DATE PRINTED 01/08/2019	SHEET NO. 21-30PSF

OFF FRAME BASEMENT & CRAWL FOUNDATION DESIGN FOR:

26' - 8 " 2-SECTION MODULAR
1 STORY- W.O ATTIC

Attic without storage where the maximum clear height between joist and rafter is less than 42 inches or req'd insulation depth exceeds the depth of the bottom chord.

PERIMETER ANCHORED SYSTEM- BUILDING IS SECURED TO FOUNDATION WALLS TO SUPPORT WIND AND SEISMIC FORCES.

SIDEWALLS ARE SUPPORTED (PERIMETER BLOCKED)

BUILDING CODE INFORMATION:

IRC (2015)
ASCE 7-10

2018 NORTH CAROLINA RESIDENTIAL CODE

BUILDING SITE INFORMATION:

*MAXIMUM ULTIMATE/DESIGN WIND SPEED & EXPOSURE: 155/ 120 MPH EXPOSURE C-enclosed

MINIMUM SOIL BEARING CAPACITY: 2000 PSF

MAXIMUM GROUND SNOW(S): 20 PSF, 30 PSF

Flat roof snow load (Pg)=20.0 PSF ,23.1 PSF

SEISMIC DESIGN CATEGORY: C

DESIGN SPECTRAL RESPONSE (S_{DS}): 0.49

SEISMIC SOIL SITE CLASS: D

HOME INFORMATION:

UNIT WIDTH: 26' - 8 "

MAX. UNIT LENGTH: 72 ft.

ROOF PITCH: 3/12 to 6/12

DESIGN LOADS: 40 PSF FL. LL., 7PSF T.C.D.L., 8PSF B.C.
D.L., 13PSF FL. DL. &, 10PSF B.C.L.L

MAX. SIDEWALL HEIGHT: 108 INCHES

TOTAL MATING WALL RIM JOIST BEAMS: (4) 2X10 #2 SPF

RIM JOIST SPLICES: 6" X 8" MiTek MT20 metal plates each side

OFF FRAME FLOOR

PLANT NUMBER: 958

**Ultimate wind speed Vult. Per ASCE 7-10/ allowable stress design wind speed Vasd*

This design is the property of CMH Manufacturing and cannot be used without authorization. This design is exclusively for use with new homes built by CMH Manufacturing. Use with homes built by other companies is strictly prohibited.

FILENAME:958I-14.R.F.I.22.22.117()

Page 1 OF 33



APPROVED BY

NIA INC. 1/10/2019

Approval of this document does not authorize or approve any deviation or deviations from the requirements of applicable State Laws.

David Richter

PAGE DESCRIPTION	DETAIL	PAGE #
COVER		1
TABLE OF CONTENTS		2
PREFACE		3
INSTRUCTIONS		4
GENERAL NOTES		5
SOIL CLASSIFICATION (TABLE R405.1)		8
FOUNDATION WALL DESIGN		9
UNBALANCED FOUNDATIONS TABLE L	TABLE L	10
PIER AND FOOTER DESIGN TABLE M	TABLE M	11
MIN. POST CAPACITY AND FOOTER DESIGN TABLE N	TABLE N	12
PORCH AND RECESS SUPPORT AND ANCHORAGE	TABLE P	13
KEY PLAN 7 - OFF-FRAME BASEMENT	KEY 7	14
KEY PLAN 8 - OFF-FRAME CRAWL PLAN	KEY 8	15
REINFORCED PERIMETER WALL - DETAIL D2	D2	16
NON-REINFORCED MATING PIER / CRAWLSPACE ONLY (MORTAR EMBEDDED) - DETAIL D3	D3	17
REINFORCED MATING PIER / BASEMENT OR CRAWLSPACE - DETAIL D5	D5	18
MATING WALL COLUMN TIE DOWN - DETAIL D6	D6	19
ADJUSTABLE STEEL COLUMN POST / BASEMENT OR CRAWLSPACE - DETAIL D7	D7	20
NON-REINFORCED PERIMETER SUPPORT PIER D15	D15	21
SPECIAL HIGH CAPACITY SHEARWALL HOLD-DOWN	D18	22
DOUBLE MUD SILL CONSTRUCTION OPTION.	D34	23
FLOOR TO SILL PLATE FASTENING - DETAIL E	E	24
FLOOR TO SILL PLATE FASTENING - DETAIL F	F	25
FLOOR TO SILL PLATE FASTENING - DETAIL G	G	26
FLOOR TO SILL PLATE FASTENING - DETAIL H	H	27
FLOOR TO SILL & SILL TO FOUNDATION SECUREMENT WITH DETAIL H PLATES		28
FLOOR TO SILL & SILL TO FOUNDATION SECUREMENT WITHOUT DETAIL H PLATES		31

APPROVED BY



Approval of this document does not authorize or approve any deviation or deviations from the requirements of applicable State Laws.

David Richter



Preface

This foundation design manual is dedicated to the ever-growing trend to place homes over basements and permanent foundations. CMH Manufacturing, Inc. has attempted to address the more common installation configurations. These may or may not be the only acceptable designs for basements or permanent foundations. If deviations are made from these details, it is the homeowner' s and/or installation contractor' s responsibility to obtain proper documentation and engineer' s details of construction acceptable to the local authority having jurisdictions. CMH Manufacturing, Inc. will not supply any details other than what is contained in the following design manual. If an alternate design is requested it must be provided by an independent engineer subject to local approval. The owner/contractor is responsible for any additional construction details, permits, inspections and fees associated with these items.

Setting a home over a basement or permanent foundation requires special knowledge, experience and equipment to accomplish a safe and proper set. Contractors performing this type of installation must be licensed, bonded and insured to protect all aspects of this type of work.

APPROVED BY
 1/10/2019
NIA INC.
Approval of this document does not authorize or approve any deviation or deviations from the requirements of applicable State Laws.
David Richter

Instructions

1. Determine site soil classification, (see table R405.1).
2. The provided foundation and anchorage designs are not applicable for the following conditions. In all these cases a complete geotechnical evaluation must be performed and foundation must be designed by a professional engineer in accordance with section 1805.8 (IBC) for site specific conditions.
 - Site contains OL, OH or Pt class soils.
 - Site contains compressible or shifting soils.
 - Site contains expansive soils per IRC (R403.1.8.1) or per local authority and adopted code.
 - Site contains soils which do not provide the minimum allowable soil bearing strength as specified per the provided designs.
 - Foundation walls support unbalanced loads on opposite sides of building, such as a daylight basement or walk out basement where the building aspect ratio, L/W, exceeds the values specified in Table L.
 - Site with soils subject to liquefaction or soil containing high concentration of sulfate.
3. Determine foundation wall height for each wall of foundation. Reference **Detail – D1 or D2** for wall height.
4. Determine height of backfill for each wall of foundation. Reference **Table L** when backfill heights along the foundation wall are unbalanced. Reference **Detail – D1 or D2** for perimeter foundation wall construction.
5. Determine what type of mateline supports will be used. Reference **Detail - D3, D4, D5 or D7** for mateline columns and **Detail – D14** for cross beams.
6. Determine if type H connector plates will be used around the perimeter of the building. Fastening and anchoring tables have been provided with and without the use of the H connectors.
7. Find the **Floor to Sill Plate & Sill Plate to Foundation** table for site soil classification.
8. Find site wall height and backfill height line and follow this line across. Heights are listed as maximums, therefore any line beneath (greater height) may be utilized for items 10 ,11 & 12 below.
9. If type H connectors will be installed the table labeled **With Type H Plate Connectors** can be utilized. Note (6) will specify spacing for H plates along sidewalls and Note (7) will specify spacing for H plates along each endwall.
10. Select desired rim to sill connection from line in table (E, F or G for sidewalls and E or G for endwalls).
11. Select desired anchor type (4 or 5) for sill to foundation wall connection and determine anchor spacing for sidewall and endwall under corresponding column.
12. Determine if shearwall foundation holddowns are required by checking far right column within selected row. See **Shearwall Foundation Holddown Detail (Detail D18)** for connection requirements .

The above process may be repeated as desired for different foundation wall and backfill combinations.



General Notes

1. Foundation plans and details developed by CMH Manufacturing, Inc. are provided to our company owned sales centers and wholesale distribution partners. Alternate foundation systems may be used in lieu of these plans provided they are designed by a local professional Engineer or Architect familiar with the local soil and climate conditions, and are approved by the local authority having jurisdiction.
2. All notes stating "in field" or "by owner" are obligations pertaining to owner/contractor.
3. Owner /Contractor shall provide complete foundation, including footing drains, vapor barrier, sill plate, anchor bolts, stair area, slab and footing reinforcement along with damp proofing, waterproofing, backfill, and all finish work per Chapter 4 of IRC or per adopted local building code.
4. Owner/Contractor shall be responsible for performing all work in accordance with previously approved construction details and obtaining all necessary inspections as required by local or state authorities.
5. Not designed for areas likely to have collapsible, expansive, compressible, shifting, liquifaction, soil containing high concentration of sulfate or other unknown soil characteristics. In these conditions a local engineer must provide foundation design and the building official shall determine whether to require a soil test to determine the soil characteristics. This soil test shall be made by an approved testing agency using an approved method.
6. Pier spacing is dimensioned to centerline unless otherwise noted.
7. The foundation dimensions shown are nominal. An increase in module width should be expected due to module expansion, setting tolerances, etc. The foundation contractor should consult with the manufacturer of the modules prior to construction of the foundation to determine the actual width of the home and placement of anchors.
8. All steel support columns shall have protective coating and a load capacity equal to or greater than specified on foundation plan (k=1000 pounds).
9. All foundation construction materials and installation shall be in accordance with all state and local codes.
10. Backfill shall not be placed against the wall until the wall has sufficient strength and has been anchored to the floor above or has been sufficiently braced to prevent damage by the backfill. Heavy-equipment must be restricted to a minimum distance to the foundation at least equal to the depth of the foundation.
11. Solid cap block or cement fill required at top courses of all masonry piers or pilasters.
12. The foundation design has been designed to be placed in the seismic zone indicated on the cover of this document. Please note that all CMH structures have been designed for seismic (zone/category) A, B, or C only, unless otherwise noted on floor plan and cover page of these instructions.
13. All piers shall be constructed of 8"x8"x16" concrete masonry units conforming to ASTM C90 with a minimum compressive strength of 700 psi. Masonry foundation walls must be laid in type m or s mortar. When required per tables or details, piers of masonry units shall be laid in type m or s mortar. All dry stack masonry should be surfaced bonded with an approved adhesive product.

APPROVED BY

NIA INC.
1/10/2019

Approval of this document does not authorize or approve any deviation or deviations from the requirements of applicable State Laws.

David Richter

14. All reinforcing steel shall be Grade 60 minimum. All splices shall be lapped 24" minimum and splices shall be offset 30" minimum within same footer.
15. All concrete grout shall be 3000 psi at 28 days.
16. Reference the model plan drawing for specific foundation layout.
17. Concrete footings shall have a minimum compressive strength of 3000 psi at 28 days. Concrete foundation walls and other concrete exposed to weather shall have a minimum compressive strength of 3000 psi at 28 days and in moderate and severe weather areas the concrete shall be air entrained no less than 5 percent and not more than 7 percent. See table R301.2(1) and R402.2 of IRC
18. All exterior footings shall be placed at least 12" below the undisturbed ground surface. All exterior footings shall extend below the frost line or otherwise frost protected in accordance with Sections R403.1.4.1 through R403.1.4.2 of IRC or per adopted local building code.
19. Top of foundation walls shall extend a minimum of 6" above finished adjacent grade. Wood framing members, including wood sheathing, that rest on exterior foundation walls and are less than 8" from exposed earth shall be of naturally durable or preservative-treated wood. Wood floor joist shall not be closer than 18" from exposed ground in under floor space.
20. Contractor shall verify all site conditions and dimensions prior to starting foundation. Notify home manufacturer of any discrepancies immediately.
21. The foundation must be designed and built to local codes and ordinances and must be approved and inspected by local building officials.
22. Access shall be to all under floor spaces. Access shall be a minimum of 18" by 24" . If mechanical equipment is installed in this area, please refer to the Mechanical Code for minimum access opening. Through wall access openings shall not be located under an exterior door.
23. Under floor space shall be ventilated with a net area ratio not less than 1 square foot for each 150 square feet of under floor space area placed in accordance with local codes. Ratio may be reduced to 1/1,500 where ground is covered with a 6-mil polyethylene or approved vapor retarder.
24. Field installed wiring in basement is subject to local inspection. Basement smoke alarms must be installed at foot of stairs and interconnected with home smoke alarms and tested on site. Smoke alarms must be located, installed, and tested in conformance with local building requirements.
25. Large clear spans along masonry wall require a column or pier at each end. See model specific foundation plan for required capacity and additional column requirements.
26. Basement stairs (widths, handrails, clearances, headroom, landings, fire protection, etc.) are the responsibility of the owner/contractor and must be constructed to comply with local building codes.
27. Owner/contractor shall not alter basement stair opening without written approval from CMH Manufacturing, Inc.

FILENAME:958I-14.R.F.I.22.22.117(L)

APPROVED BY

1/10/2019
Approval of this document does not authorize or approve any deviation or deviations from the requirements of applicable State Laws.
David Richter

Page 6 OF 33

28. Lighting and receptacles in basement are the responsibility of owner/contractor.
29. Termite protection shall be provided per the building code and local requirements and are responsibility of owner/contractor.
30. Ground snow load is indicated on foundation plans. Snow load must be verified per locality. Building has not been designed to be located within a Tsunami design zone.
31. This structure has not been designed to be located within flood hazard locations or in Coastal A Zones. When site is located in a flood hazard area or in Coastal A Zones as determined by the local authority having jurisdiction or flood hazard maps. The unit shall have lowest floor elevated above the design floor elevation. Foundation and anchorage designs shall be provided by a local engineer in conformance with locally adopted building code and ASCE-24-14.
32. All connection hardware, anchor bolts, straps, hold-downs, washers and fasteners shall be minimum of ASTM A653 Type G185 zinc coated galvanized or stainless when in contact with pressure treated sill plates or other pressure treated lumber.
33. Radon control, when required by a local jurisdiction, shall be provided and installed by others in accordance with appendix F of the IRC.
34. Topographic wind effects have not been considered. Home has not been designed to be located in areas designated as having local historical data documenting structural damage to buildings caused by wind speed-up at isolated hills, ridges and escarpments.
35. Surface drainage shall be devirted to a storm sewer or other approved collection point. Lots shall be graded to drain surface water away from foundation walls. The grade shall fall a minimum of 6 inches within the first 10 feet.
- 36 A 6-mil-thick polyethylene moisture barrier shall be applied over the porous layer with the basement floor constructed over the polyethylene.
37. Concrete and Masonry Foundation walls that retain earth and enclose interior spaces and floors below grade shall be damp proofed from the top of the footing to the finished grade. Masonry walls shall have not less than 3/8" Portland cement parging applied to the exterior of the wall. The parging shall be damp proofed in accordance with one of the following.
- a. Bituminous coating, b. 3 pound per sq. yard of arcylic modified cement, c. 1/8" coat of surface-bonding cement complying with ASTM C887, d. Material permitted for waterproofing per Section R406.2, e. Other approved methods or materials.
38. Concrete and masonry foundation walls that retain earth and enclose interior spaces and floors below grade in areas of high water table or other severe soil-water conditions shall be waterproofed from the top of the footing to the finished grade in accordance with one of the following:
- a. 2-ply hot-mopped felts, b. 55 pound rolled roofing, c. 6-mil polyvinyl chloride, 6-mil polyethylene, d. 40-mil polymer-modified asphalt., e, 60-mil flexible polymer cement, f. 1/8" cement-based, fiber-reinforced, waterproof coating, g. 60-mil solvent-free liquid-applied synthetic rubber.
39. If building is located within a wind borne debris region glazed openings shall be protected from wind borne debris. Wind Borne debris protection is the responsibility of others.
40. When Geotechnical report is required or available, all recommendations shall be followed and geotechnical engineer shall review all foundation plans to verify applicability with recommendations and engineer shall be present on regular basis during site preparation, fill placement and foundation excavation.
41. Self-closing rated doors shall be installed between garage and house (on-site by other).(R302.5.1)
- 42.Reserved.
43. A 6-mil polyethylene or approved vapor retarder with joints lapped not less than 12 inches shall be placed between the concrete floor slab and the base course or the prepared subgrade.

APPROVED BY

1/10/2019
I hereby approve any deviation or deviations from the requirements of applicable State Laws.
David Richter

SOIL CLASSIFICATION

TABLE R405.1 W/ NC admendments						
LATERAL SOIL LOAD	UNIFIED SOIL CLASSIFICATION SYSTEM SYMBOL	SOIL DESCRIPTION	DRAINAGE CHARACTERISTICS ^a	FROST HEAVE POTENTIAL	VOL. CHANGE POTENTIAL EXPANSION ^b	ALLOWABLE SOIL PRESSURE
30 psf LATERAL SOIL LOAD	GW	Well-graded gravels, gravel sand mixtures, little or no fines	Good	Low	Low	5000
	GP	Poorly graded gravel or gravels sand mixtures, little or no fines	Good	Low	Low	5000
	SW	Well-graded gravels, gravelly sands, little or no fines	Good	Low	Low	3000
	SP	Poorly graded sand, or gravelly sands, little or no fines	Good	Low	Low	3000
45 psf LATERAL SOIL LOAD	GM	Silty gravels, gravel-sand-silt mixtures	Good	Medium	Low	3000
	SM	Silty sand, sand-silt mixtures	Good	Medium	Low	3000
	GC	Clayey gravels, gravel-sand-clay mixtures	Medium	Medium	Low	3000
60 psf LATERAL SOIL LOAD	SC	Clayey sands, sand-clay mixture	Medium	Medium	Low	3000
	ML	Inorganic silts and very fine sands, rock flour, silty or clayey fine sands or clayey silts with slight plasticity	Medium	High	Low	2000*
	CL	Inorganic clays of low to medium plasticity, gravelly clays, sandy clays, silty clays, lean clays	Medium	Medium	Medium to Low	2000*
	CH	Inorganic clays of high plasticity, fat clays	Poor	Medium	High	2000*
	MH	Inorganic silts, micaceous or diatomaceous fine sandy or silty soils, elastic silts	Poor	High	High	2000*
SPECIAL INSPECTION REQUIRED	OL	Organic silts and organic silty clays of low plasticity	Poor	Medium	Medium	SPECIAL INSPECTION REQUIRED
	OL	Organic clays of medium to high plasticity, organic silts	Unsatisfactory	Medium	High	
	Pt	Peat and other highly organic soils	Unsatisfactory	Medium	High	

a. The percolation rate for good drainage is over 4 inches per hour, medium drainage is 2 inches to 4 inches per hour, and poor is less than 2 inches per hour.

b. Soils with low potential expansion typically have a plasticity index (PI) of 0 to 15, soils with a medium potential expansion have a PI of 10 to 35 and soils with a high potential expansion have PI greater than 20.

* Where the building official determines that in place soils with an allowable bearing capacity of less than 2000 psf are likely to be present at the site, the allowable bearing capacity shall be determined by a soils investigation.

APPROVED BY

 1/10/2019
David Richter

Approval of this document does not authorize or approve any deviation or deviations from the requirements of applicable State Laws.

TABLE R404.1.1:IRC (2015) PERIMETER FOUNDATION WALL MINIMUM REQUIREMENTS [Seismic Seismic Zone: Design]

Max. Wall Height	Maximum Unbalanced Fill*	GW, GP, SW, & SP Soil Class (30 PSF)			GM, GC, SM-SC, & ML Soil Class (45 PSF)			SC, MH, ML-CL, & Inorganic CL Soil Class (60 PSF)		
		Plain Masonry 1 Walls	8" Reinforced Masonry Walls ^{5,9}	8" Poured Concrete Walls ^{6,7}	Plain Masonry 1 Walls	8" Reinforced Masonry Walls ^{5,9}	8" Poured Concrete Walls ^{6,7}	Plain Masonry 1 Walls	8" Reinforced Masonry Walls ^{5,9}	8" Poured Concrete Walls ^{6,7}
0 to 5 feet	4	6 in. solid (3) or 8 in.	-	PC	6 in. solid (3) or 8 in.	-	PC	6 in. solid (3) or 8 in.	-	PC
	5	6 in. solid (3) or 8 in.	-	PC	8 in.	-	PC	10 in.	-	PC
6 feet to 7 feet	4	6 in. solid (3) or 8 in.	#4 @ 48 in. o.c.	PC	8	#4 @ 48 in. o.c.	PC	8	#4 @ 48 in. o.c.	PC
	5	6 in. solid (3) or 8 in.	#4 @ 48 in. o.c.	PC	10 in.	#4 @ 48 in. o.c.	PC	10 in.	#4 @ 48 in. o.c.	PC
	6	10 in.	#4 @ 48 in. o.c.	PC	12 in.	#5 @ 48 in. o.c.	PC	10 in. solid (3)	#5 @ 48 in. o.c.	#5 @ 48 in. o.c.
	7	12 in.	#5 @ 48 in. o.c.	PC	10 in. solid (3)	#6 @ 48 in. o.c.	#5 @ 46 in. o.c.	12 in. solid (3)	#6 @ 40 in. o.c.	#6 @ 48 in. o.c.
8 feet	4	6 in. solid (3) or 8 in.	#4 @ 48 in. o.c.	PC	6 in. solid (3) or 8 in.	#4 @ 48 in. o.c.	PC	8	#4 @ 48 in. o.c.	PC
	5	6 in. solid (3) or 8 in.	#4 @ 48 in. o.c.	PC	10 in.	#4 @ 48 in. o.c.	PC	12 in.	#4 @ 48 in. o.c.	PC
	6	10 in.	#4 @ 48 in. o.c.	PC	12 in.	#5 @ 48 in. o.c.	PC	12 in. solid (3)	#5 @ 48 in. o.c.	#6@32in o.c.
	7	12 in.	#5 @ 48 in. o.c.	PC	12 in. solid (3)	#6 @ 48 in. o.c.	#5 @ 41 in. o.c.	Footnote (4)	#6 @ 40 in. o.c.	#6@32 in. o.c.
9 feet	8	10 in. solid (3)	#5 @ 48 in. o.c.	#6@41	12 in. solid (3)	#6 @ 48 in. o.c.	#6 @ 43 in. o.c.	Footnote (4)	#6 @ 32 in. o.c.	#6@18 in. o.c.
	4	6 in. solid (3) or 8 in.	#4 @ 48 in. o.c.	PC	6 in. solid (3) or 8 in.	#4 @ 48 in. o.c.	PC	8 in.	#4 @ 48 in. o.c.	PC
	5	8 in.	#4 @ 48 in. o.c.	PC	10 in.	#4 @ 48 in. o.c.	PC	12 in.	#5 @ 48 in. o.c.	PC
	6	10 in.	#4 @ 48 in. o.c.	PC	12 in.	#4 @ 48 in. o.c.	PC	12 in. solid (3)	#6 @ 48 in. o.c.	#6@35 in. o.c.
	7	12 in.	#5 @ 48 in. o.c.	PC	12 in. solid (3)	#6 @ 48 in. o.c.	#6@35 in. o.c.	Footnote (4)	#6 @ 40 in. o.c.	#6@32 in. o.c.
10 feet	8	12 in. solid (3)	#6 @ 48 in. o.c.	#6@36 in. o.c.	Footnote (4)	#6 @ 40 in. o.c.	#6@32 in. o.c.	Footnote (4)	#6 @ 24 in. o.c.	#6@28 in. o.c.
	9	Footnote (4)	#6 @ 40 in. o.c.	#6@35 in. o.c.	Footnote (4)	#6 @ 24 in. o.c.	#6@25 in. o.c.	Footnote (4)	#6 @ 16 in. o.c.	#6@24 in. o.c.
	10	NA	#6 @ 48 in. o.c.	#6 @ 35 in. o.c.	NA	#6 @ 32 in. o.c.	#6 @ 29 in. o.c.	NA	#6 @ 24 in. o.c.	#6 @ 21 in. o.c.
10 feet	9	NA	#6 @ 40 in. o.c.	#6@34 in. o.c.	NA	#6 @ 24 in. o.c.	#6@22 in. o.c.	NA	#6 @ 16 in. o.c.	#6@16 in. o.c.
	10	NA	#6 @ 32 in. o.c.	#6 @ 27 in. o.c.	NA	#6 @ 16 in. o.c.	#6 @ 17 in. o.c.	NA	#6 @ 16 in. o.c.	#6 @ 13 in. o.c.

*Unbalanced backfill height is the difference in height between the exterior finish grade level and the top of the basement slab or crawl space grade.

Backfill shall be placed only AFTER the home has been anchored to the foundation wall.

(1) - All block must conform to ASTM C90 (700 psi rated) and be laid in a running bond of Type M or S mortar with overlapping pattern .

UngROUTED hollow masonry units are permitted except where otherwise indicated.

(3) - Solid grouted hollow units or solid masonry units.

(4) - Wall construction per reinforced units or design required.

(5) - Vertical reinforcement shall be Grade 60 minimum. The distance from the face of the soil side of the wall to the center of vertical reinforcement shall be at least 5".

(6) - PC = Plain Concrete (Concrete with less reinforcement than minimum for reinforced concrete)

(7) - All reinforcement shall be Grade 60 minimum. The distance from the face of the soil side of the wall to the vertical reinforcement shall be at least 6 1/16", but not more than 6 11/16".

'All information above has been extracted from the 2009 IRC Tables R404.1.1(1), Tables R404.1.1(2) Tables R404.1.2(3)

(8) Reserved

(9) Reserved



FILENAME:958I-14.R.F.I.22.22.117(_)

Maximum Aspect Ratio, L/W for Unbalanced Foundations

Maximum Wall Height	Maximum Unbalanced Fill	SOIL CLASS		
		GW, GP, SW, & SP (30 PSF)	GM, GC, SM-SC, & ML (45 PSF)	SC, MH, ML-CL, & Inorganic CL (60 PSF)
7 feet	4	4.0	4.0	4.0
	5	4.0	3.4	2.6
	6	3.0	2.0	1.5
	7	1.9	1.2	0.9
8 feet	4	4.0	4.0	4.0
	5	4.0	3.9	2.9
	6	3.4	2.3	1.7
	7	2.1	1.4	1.1
9 feet	8	1.4	1.0	0.7
	4	4.0	4.0	4.0
	5	4.0	4.0	3.3
	6	3.8	2.6	1.9
9 feet	7	2.4	1.6	1.2
	8	1.6	1.1	0.8
	9	1.1	0.8	0.6

Instructions:

Where foundation wall support unbalanced load on opposite sides of building such as daylight basement, the building aspect ratio, L/W, shall not exceed the value specified in Table

- 1 - Determine foundation wall height, unbalanced fill depth, and soil class to determine aspect ratio from table above.
- 2 - Multiple "W" times aspect ratio.
- 3 - Result is equal to the maximum allowable building length on the exposed side.

Example 1 - check sidewall for 26'-8" x 60'-0" home.

Basement Wall Height = 8'-0"

Unbalanced backfill = 7'-0"

Soil Class = SP

Aspect Ratio from Table above = 2.1

$26.67 \times 2.1 = 56'-0"$ max. allowable length - **example fails**

Try again using 6'-0" max. unbalanced fill with an aspect ratio of 3.4.

$26.67 \times 3.4 = 90'-8"$ max. allowable length - **example passes**

Max. allowable backfill is 6'-0"

Example 2 - check endwall for 26'-8" x 60'-0" home.

Basement Wall Height = 8'-0"

Unbalanced backfill = 7'-0"

Soil Class = SP

Aspect Ratio from Table above = 2.1

$60 \times 2.1 = 126'-0"$ max. allowable length - **example passes**

"L" = total overall dimension of the building on the exposed side

"W" = the total overall dimension of the building on the side adjacent to the exposed side

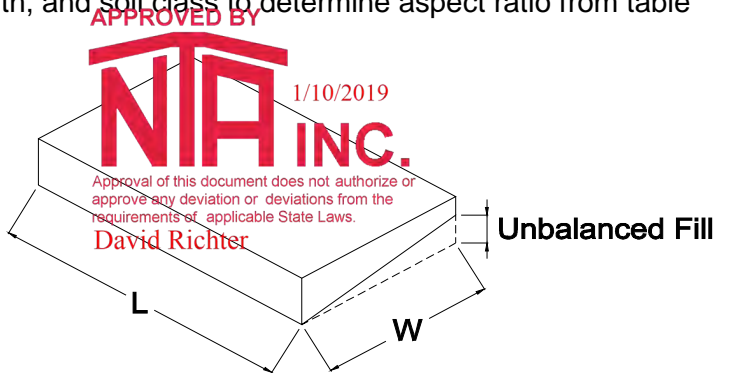

Required Rim Joist to Sill Plate Fastening at wall "L".
Use a 20 Gauge metal angle clip at 24" o.c. with (5) 8d nails per leg or an approved connector supplying 230 pounds per linear foot capacity.

*Page extracted from 2006 IRC section R404.1.5 & Table R404.1(3)

Schult	
UNBALANCED FOUNDATIONS (TABLE L)	
DATE: 3/27/07	FILENAME:9581-14.R.F.I.22.22.117(L)
PAGE #:	
Page 10 OF 33	

**TABLE M - MINIMUM CONCRETE BLOCK PIER AND FOOTER SIZE
AT MATING WALL COLUMNS (REF. DETAILS D3 OR D5)**

GROUND SNOW	20	30				# of Uplift Ties	
MAXIMUM MATING LINE SPAN BETWEEN MATING WALL COLUMN SUPPORTS	4'	(S) 26"x26"X9" OR 30" Dia. X 11"	(S) 26"x26"X9" OR 30" Dia. X 11"				0
	6'	(S) 26"x26"X9" OR 30" Dia. X 11"	(D) 34"x34"X9" OR 40" Dia. X 16"				1
	8'	(D) 34"x34"X9" OR 40" Dia. X 16"	(D) 34"x34"X9" OR 40" Dia. X 16"				1
	10'	(D) 34"x34"X9" OR 40" Dia. X 16"	(D) 34"x34"X9" OR 40" Dia. X 16"				1
	12'	(D) 34"x34"X9" OR 40" Dia. X 16"	(D) 34"x34"X9" OR 40" Dia. X 16"				1
	14'	(D) 34"x34"X10" OR 40" Dia. X 16"	(D) 34"x34"X10" OR 40" Dia. X 16"				1
	16'	(D) 34"x34"X12" OR 40" Dia. X 16"	(D) 34"x34"X12" OR 40" Dia. X 16"				1
	18'	(D) 34"x34"X14" OR 40" Dia. X 16"	(D) 34"x34"X14" OR 40" Dia. X 16"				1
	20'	(D) 34"x34"X16" OR 40" Dia. X 16"	(D) 34"x34"X16" OR 40" Dia. X 16"				1
	22'	(D) 34"x34"X18" OR 40" Dia. X 18"	(D) 34"x34"X18" OR 40" Dia. X 18"				1
	24'	(D) 34"x34"X20" OR 40" Dia. X 20"	(D) 34"x34"X20" OR 40" Dia. X 20"				1
	26'	(D) 34"x34"X22" OR 40" Dia. X 22"	(D) 34"x34"X22" OR 40" Dia. X 22"				1
	28'	(D) 34"x34"X24" OR 40" Dia. X 24"	(D) 34"x34"X24" OR 40" Dia. X 24"				1
	30'	(D) 34"x34"X27" OR 40" Dia. X 27"	(T) 42"x42"X18" OR 48" Dia. X 20"				1
	32'	(D) 34"x34"X29" OR 40" Dia. X 29"	(T) 42"x42"X19" OR 48" Dia. X 20"				1
34'	(D) 34"x34"X31" OR 40" Dia. X 31"	(T) 42"x42"X20" OR 48" Dia. X 20"				2	
36'	(D) 34"x34"X33" OR 40" Dia. X 33"	(T) 42"x42"X22" OR 48" Dia. X 22"				2	
46'	(T) 42"x42"X29" OR 48" Dia. X 29"	(T) 42"x42"X29" OR 48" Dia. X 29"				2	
SUPPORTS UNDER MATING OPENING AS CLEARSPANS IN FEET							
PIER SPACING	8.3'	8.3'					
PIER CONFIG.	(S) 26"x26"X9" OR 24" Dia.	(S) 26"x26"X9" OR 24" Dia.					
SUPPORTS UNDER MATING WALLS- CLEARSPANS IN FEET							
PIER SPACING	7.'	7.'					
PIER CONFIG.	(S) 26"x26"X9" OR 27" Dia.	(D) 34"x34"X9" OR 28" Dia.					

Girder beams construction to be (4) 2X10 #2 SPF joists. Splices 6" X 8" MiTek MT20 metal plates each side

Chart Key:

(Pier Configuration) Min. footer width (inches) x Min. footer length (inches) x Min. footer depth (inches)

(S)= Single stack block configuration.

(D)= Double stack block configuration.

(T)= Triple stack block configuration.

(DR)=Double stack reinforced & fully grouted configuration.

IE. For 20 psf 160" box with 14' opening:Double stack pier on a 34"x 34" sq. footer 10" deep footing.

27' 1 STORY- W.O ATTIC OFF FRAME BASEMENT & CRAWL With Roof Pitch of 3/12 Min. to 6/12 Max.

NOTES: 1 DESIGNED FOR 120 MPH MAX. WIND SPEED.

2 DESIGNED FOR 2000 PSF MIN. ALLOWABLE SOIL BEARING CAPACITY.

3 *Ultimate wind speed Vult. Per ASCE 7-10/ allowable stress design wind speed Vasd & ASCE 7-10 & 2018 NORTH CAROLINA RESIDENTIAL CODE

4 MAX. MATING WALL OPENINGS LISTED IN CHART ASSUME OPENING IN BOTH HALVES. IF ANCHOR IS TIED TO ONLY ONE

COLUMN (ONE HALF) THEN HALF THE OPENING SIZE CAN BE USED WHEN LOOKING UP VALUE IN TABLE ABOVE. PIERS

SUPPORTS REQUIRED AT EACH SIDE OF DOOR OPENINGS AND ALL EXTERIOR WALL OPENINGS GREATER THAN 4'.

5 WHEN PIER CONFIGURATION IS NOT GIVEN IN CHART THE ACTUAL LOADS EXCEED ALL

PREDESIGNED PIERS AND A LOCAL ENGINEER MUST DESIGN THE SUPPORTS FOR THE

GIVEN LOADS (- UPLIFT/ + GRAVITY LOADS).

6 ALL PIERS SHALL BE EMBEDDED IN TYPE M OR S MORTAR.

7.Round footers or Round Piles with diameter as required above may be used as alternate to square footing or square footing and block piers.

APPROVED BY



Approval of this document does not authorize or approve any deviation or deviations from the requirements of applicable State Laws.

David Richter

FILENAME:958I-14.R.F.I.22.22.117()

TABLE N - STRUCTURAL STEEL POST AND FOOTER SIZE AT MATING WALL COLUMNS (REF. DETAIL D7)

GROUND SNOW	20	30				Uplift force
MAXIMUM MATING LINE SPAN BETWEEN MATING WALL COLUMN SUPPORTS	4'	(9k) 26"x26"X11"	(9k) 26"x26"X11"			0 #
	6'	(9k) 26"x26"X11"	(9k) 26"x26"X11"			204.294 #
	8'	(9k) 26"x26"X11"	(9k) 26"x26"X11"			417.992 #
	10'	(9k) 26"x26"X11"	(14k) 32"x32"X13"			631.69 #
	12'	(14k) 32"x32"X13"	(14k) 32"x32"X13"			845.388 #
	14'	(14k) 32"x32"X13"	(14k) 32"x32"X13"			1059.09 #
	16'	(14k) 32"x32"X14"	(14k) 32"x32"X14"			1272.78 #
	18'	(14k) 32"x32"X17"	(14k) 32"x32"X17"			1486.48 #
	20'	(14k) 32"x32"X19"	(14k) 32"x32"X19"			1700.18 #
	22'	(14k) 32"x32"X21"	(14k) 32"x32"X21"			1913.88 #
	24'	(14k) 32"x32"X24"	(14k) 32"x32"X24"			2127.58 #
	26'	(14k) 32"x32"X26"	(20k) 38"x38"X19"			2341.27 #
	28'	(14k) 32"x32"X29"	(20k) 38"x38"X20"			2554.97 #
	30'	(14k) 32"x32"X31"	(20k) 38"x38"X22"			2768.67 #
	32'	(14k) 32"x32"X33"	(20k) 38"x38"X24"			2982.37 #
	34'	(20k) 38"x38"X26"	(20k) 38"x38"X26"			3196.07 #
36'	(20k) 38"x38"X27"	(20k) 38"x38"X27"			3409.76 #	
46'	(20k) 38"x38"X36"	(30k) 48"x48"X23"			4478.25 #	

APPROVED BY

 1/10/2019
 Approval of this document does not authorize or approve any deviation or deviations from the requirements of applicable State Laws.
 David Richter

SUPPORTS UNDER MATING OPENING AS CLEARSPANS IN FEET

POST SPACING	8.3'	8.3' 0/C			
FOOTER SIZE	(9k) 26"x26"X11"	(9k) 26"x26"X11"			
SUPPORTS UNDER MATING WALLS- CLEARSPANS IN FEET					
POST SPACING	7.'	7.'			
FOOTER SIZE	(9k) 26"x26"X11"	(9k) 26"x26"X11"			

Girder beams construction to be (4) 2X10 #2 SPF joists. Splices 6" X 8" MiTek MT20 metal plates each side

Chart Key:

(Post Load)= Minimum allowable compression rating which post must be rated in kips (1000 lbs.).

(Post Capacity and Footer Size) Min. footer width (inches) x Min. footer length (inches) x Min. footer depth (inches)

Note: Steel piers must have a minimum steel base plate size of 4 inches x 5.5 inches which bears directly on footer sized per chart.

Minimum steel column top plate size of 4"x5.5"for 9000#; 6"x6"for 14000#; 6"x8"for 20000# & 6"x12"for 30000#

Minimum footer Reinforcement (Number of #4 bars each way):

Footer size	# of No. 4 bars	Footer size	# of No. 4 bars
26"x26"	3	38"x38"	5
32"x32"	4	48"x48"	8

27' 1 STORY- W.O ATTIC OFF FRAME BASEMENT & CRAWL With Roof Pitch of 3/12 Min. to 6/12 Max.

NOTES: 1 DESIGNED FOR 120 MPH MAX. WIND SPEED.

2 DESIGNED FOR 2000 PSF MIN. ALLOWABLE SOIL BEARING CAPACITY.

3 *Ultimate wind speed Vult. Per ASCE 7-10/ allowable stress design wind speed Vasd & ASCE 7-10 & 2018 NORTH CAROLINA RESI

4 MAX. MATING WALL OPENINGS LISTED IN CHART ASSUME OPENING IN BOTH HALVES. IF ANCHOR IS TIED TO ONLY ONE

COLUMN (ONE HALF) THEN HALF THE OPENING SIZE CAN BE USED WHEN LOOKING UP VALUE IN TABLE ABOVE. PIERS

SUPPORTS REQUIRED AT EACH SIDE OF DOOR OPENINGS AND ALL EXTERIOR WALL OPENINGS GREATER THAN 4'.

5 WHEN PIER CONFIGURATION IS NOT GIVEN IN CHART THE ACTUAL LOADS EXCEED

ALL PREDESIGNED FOOTERS AND A LOCAL ENGINEER MUST DESIGN THE SUPPORTS

FOR THE GIVEN LOADS (- UPLIFT/ + GRAVITY LOADS).

FILENAME:958I-14.R.F.I.22.22.117()

Support and anchorage for 16" Max. Recess

NON CORNER- SPANS ARE NOT LOCATED WITH 6' OF END OF HOME

PIER CONFIGURATION AND MINIMUM FOOTER SIZE UNDER SIDEWALL PORCH/ RECESS SUPPORT ^{1,4}												
GROUND SNOW			20 #		30 #		0 #		0 #		0 #	
Max. span ³	UPLIFT ¹⁰ LOAD	# Brk ²	w/ground anchors	w/concrete anchors	w/ground anchors	w/concrete anchors	w/ground anchors	w/concrete anchors	w/ground anchors	w/concrete anchors	w/ground anchors	w/concrete anchors
4	-111.63905 #	-1	(S) 26"x26"X9"	(S) 26"x26"X9"	(S) 26"x26"X9"	(S) 26"x26"X9"	(S) 26"x26"X9"	(S) 26"x26"X9"	(S) 26"x26"X9"	(S) 26"x26"X9"	(S) 26"x26"X9"	(S) 26"x26"X9"
6	-167.45858 #	-1	(S) 26"x26"X9"	(S) 26"x26"X9"	(S) 26"x26"X9"	(S) 26"x26"X9"	(S) 26"x26"X9"	(S) 26"x26"X9"	(S) 26"x26"X9"	(S) 26"x26"X9"	(S) 26"x26"X9"	(S) 26"x26"X9"
8	-223.27811 #	-1	(S) 26"x26"X9"	(S) 26"x26"X9"	(S) 26"x26"X9"	(S) 26"x26"X9"	(S) 26"x26"X9"	(S) 26"x26"X9"	(S) 26"x26"X9"	(S) 26"x26"X9"	(S) 26"x26"X9"	(S) 26"x26"X9"
10	-279.09763 #	-1	(S) 26"x26"X9"	(S) 26"x26"X9"	(S) 26"x26"X9"	(S) 26"x26"X9"	(S) 26"x26"X9"	(S) 26"x26"X9"	(S) 26"x26"X9"	(S) 26"x26"X9"	(S) 26"x26"X9"	(S) 26"x26"X9"
12	-334.91716 #	-1	(D) 34"x34"X9"	(D) 34"x34"X9"	(D) 34"x34"X9"	(D) 34"x34"X9"	(D) 34"x34"X9"	(D) 34"x34"X9"	(D) 34"x34"X9"	(D) 34"x34"X9"	(D) 34"x34"X9"	(D) 34"x34"X9"

CORNER- SPANS ARE LOCATED WITH 6' OF END OF HOME

PIER CONFIGURATION AND MINIMUM FOOTER SIZE UNDER SIDEWALL PORCH/ RECESS SUPPORT ^{1,4}												
GROUND SNOW			20 #		30 #		0 #		0 #		0 #	
Max. span ³	UPLIFT ¹⁰ LOAD	# Brk ²	w/ground anchors	w/concrete anchors	w/ground anchors	w/concrete anchors	w/ground anchors	w/concrete anchors	w/ground anchors	w/concrete anchors	w/ground anchors	w/concrete anchors
4	-38.051148 #	-1	(S) 26"x26"X9"	(S) 26"x26"X9"	(S) 26"x26"X9"	(S) 26"x26"X9"	(S) 26"x26"X9"	(S) 26"x26"X9"	(S) 26"x26"X9"	(S) 26"x26"X9"	(S) 26"x26"X9"	(S) 26"x26"X9"
6	-57.076722 #	-1	(S) 26"x26"X9"	(S) 26"x26"X9"	(S) 26"x26"X9"	(S) 26"x26"X9"	(S) 26"x26"X9"	(S) 26"x26"X9"	(S) 26"x26"X9"	(S) 26"x26"X9"	(S) 26"x26"X9"	(S) 26"x26"X9"
8	-76.102296 #	-1	(S) 26"x26"X9"	(S) 26"x26"X9"	(S) 26"x26"X9"	(S) 26"x26"X9"	(S) 26"x26"X9"	(S) 26"x26"X9"	(S) 26"x26"X9"	(S) 26"x26"X9"	(S) 26"x26"X9"	(S) 26"x26"X9"
10	-95.12787 #	-1	(S) 26"x26"X9"	(S) 26"x26"X9"	(S) 26"x26"X9"	(S) 26"x26"X9"	(S) 26"x26"X9"	(S) 26"x26"X9"	(S) 26"x26"X9"	(S) 26"x26"X9"	(S) 26"x26"X9"	(S) 26"x26"X9"
12	-114.15344 #	-1	(D) 34"x34"X9"	(D) 34"x34"X9"	(D) 34"x34"X9"	(D) 34"x34"X9"	(D) 34"x34"X9"	(D) 34"x34"X9"	(D) 34"x34"X9"	(D) 34"x34"X9"	(D) 34"x34"X9"	(D) 34"x34"X9"

APPROVED BY
NIA INC.

Support and anchorage for 48" Max. Porch Depth

NON CORNER- SPANS ARE NOT LOCATED WITH 6' OF END OF HOME

PIER CONFIGURATION AND MINIMUM FOOTER SIZE UNDER SIDEWALL PORCH/ RECESS SUPPORT ^{1,4}												
GROUND SNOW			20 #		30 #		0 #		0 #		0 #	
Max. span ³	UPLIFT ¹⁰ LOAD	# Brk ²	w/ground anchors	w/concrete anchors	w/ground anchors	w/concrete anchors	w/ground anchors	w/concrete anchors	w/ground anchors	w/concrete anchors	w/ground anchors	w/concrete anchors
4	56.111366 #	1	(S) 26"x26"X9"	(S) 26"x26"X9"	(S) 26"x26"X9"	(S) 26"x26"X9"	(S) 26"x26"X9"	(S) 26"x26"X9"	(S) 26"x26"X9"	(S) 26"x26"X9"	(S) 26"x26"X9"	(S) 26"x26"X9"
6	84.167049 #	1	(S) 26"x26"X9"	(S) 26"x26"X9"	(S) 26"x26"X9"	(S) 26"x26"X9"	(S) 26"x26"X9"	(S) 26"x26"X9"	(S) 26"x26"X9"	(S) 26"x26"X9"	(S) 26"x26"X9"	(S) 26"x26"X9"
8	112.22273 #	1	(S) 26"x26"X9"	(S) 26"x26"X9"	(S) 26"x26"X9"	(S) 26"x26"X9"	(S) 26"x26"X9"	(S) 26"x26"X9"	(S) 26"x26"X9"	(S) 26"x26"X9"	(S) 26"x26"X9"	(S) 26"x26"X9"
10	140.27841 #	1	(S) 26"x26"X9"	(S) 26"x26"X9"	(S) 26"x26"X9"	(S) 26"x26"X9"	(S) 26"x26"X9"	(S) 26"x26"X9"	(S) 26"x26"X9"	(S) 26"x26"X9"	(S) 26"x26"X9"	(S) 26"x26"X9"
12	168.3341 #	1	(D) 34"x34"X9"	(D) 34"x34"X9"	(D) 34"x34"X9"	(D) 34"x34"X9"	(D) 34"x34"X9"	(D) 34"x34"X9"	(D) 34"x34"X9"	(D) 34"x34"X9"	(D) 34"x34"X9"	(D) 34"x34"X9"

Approval of this document does not authorize or approve any deviation or deviations from the requirements of applicable State Laws.
DAVID Richter

CORNER- SPANS ARE LOCATED WITHIN 6' OF END OF HOME

PIER CONFIGURATION AND MINIMUM FOOTER SIZE UNDER SIDEWALL PORCH/ RECESS SUPPORT ^{1,4}												
GROUND SNOW			20 #		30 #		0 #		0 #		0 #	
Max. span ³	UPLIFT ¹⁰ LOAD	# Brk ²	w/ground anchors	w/concrete anchors	w/ground anchors	w/concrete anchors	w/ground anchors	w/concrete anchors	w/ground anchors	w/concrete anchors	w/ground anchors	w/concrete anchors
4	162.38756 #	1	(S) 26"x26"X9"	(S) 26"x26"X9"	(S) 26"x26"X9"	(S) 26"x26"X9"	(S) 26"x26"X9"	(S) 26"x26"X9"	(S) 26"x26"X9"	(S) 26"x26"X9"	(S) 26"x26"X9"	(S) 26"x26"X9"
6	243.58134 #	1	(S) 26"x26"X9"	(S) 26"x26"X9"	(S) 26"x26"X9"	(S) 26"x26"X9"	(S) 26"x26"X9"	(S) 26"x26"X9"	(S) 26"x26"X9"	(S) 26"x26"X9"	(S) 26"x26"X9"	(S) 26"x26"X9"
8	324.77512 #	1	(S) 26"x26"X9"	(S) 26"x26"X9"	(S) 26"x26"X9"	(S) 26"x26"X9"	(S) 26"x26"X9"	(S) 26"x26"X9"	(S) 26"x26"X9"	(S) 26"x26"X9"	(S) 26"x26"X9"	(S) 26"x26"X9"
10	405.9689 #	1	(S) 26"x26"X9"	(S) 26"x26"X9"	(S) 26"x26"X9"	(S) 26"x26"X9"	(S) 26"x26"X9"	(S) 26"x26"X9"	(S) 26"x26"X9"	(S) 26"x26"X9"	(S) 26"x26"X9"	(S) 26"x26"X9"
12	487.16268 #	1	(D) 34"x34"X9"	(D) 34"x34"X9"	(D) 34"x34"X9"	(D) 34"x34"X9"	(D) 34"x34"X9"	(D) 34"x34"X9"	(D) 34"x34"X9"	(D) 34"x34"X9"	(D) 34"x34"X9"	(D) 34"x34"X9"

- NOTES:
- Piers supports are required under all porch/ recess post and at intersection of sidewall (see key plan).
 - # Brk- Number of uplift brackets required under the support column. Brackets per Detail D6. Brackets may be installed individually or in pairs and must be tied to a ground anchor or concrete anchor with a minimum design capacity of 3150#. An alternate uplift connector may be used which has the required uplift load indicated above.
 - NG- Indicates that uplift exceeds standard angle and tie down capacity and alternate design is require.
 - Max. Span- Maximum distance between adjacent porch post or supports as measure parallel to box length.
 - Piers- Indicates the minimum CMU block configuration (S)ingle, (D)ouble, (T)riple or (DR)ouble (R)enforced and minimum footer size. See Detail D3 of D4 for pier configuration.
 - w/ ground anchors- Minimum footer size for gravity load support at post. Uplift is taken to ground anchor anchors placed in soil.
 - w/ concrete anchors- Minimum footer size based on gravity and uplift. Concrete anchors embedded into foot carry uplift load.
 - off frame basement & crawl foundation design for: 26' - 8" 2-section modular
 - designed for 120 mph max. wind speed.
 - Desgin for 2000 psf min. allowable soil bearing capacity.
 - Designed to the *Ultimate wind speed Vult. Per ASCE 7-10/ allowable stress design wind speed Vasd & ASCE 7-10

Schult	
PORCH & RECESS (TABLE P)	
DATE: 3/27/07	9581-14.R.F.I.22.22.117(L)
PAGE #:	Page 13 OF 33

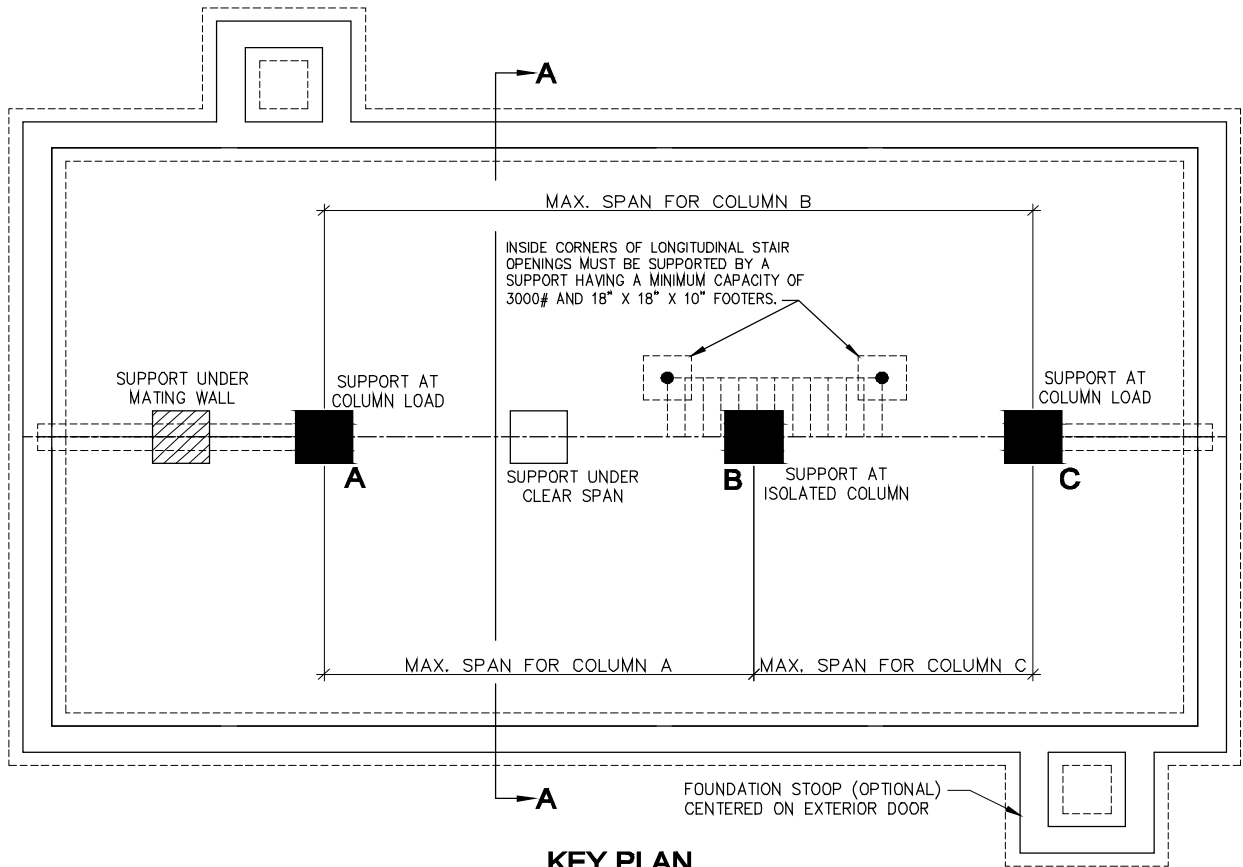

KEY PLAN
OFF-FRAME BASEMENT - 2 SECTION
 NOT TO SCALE

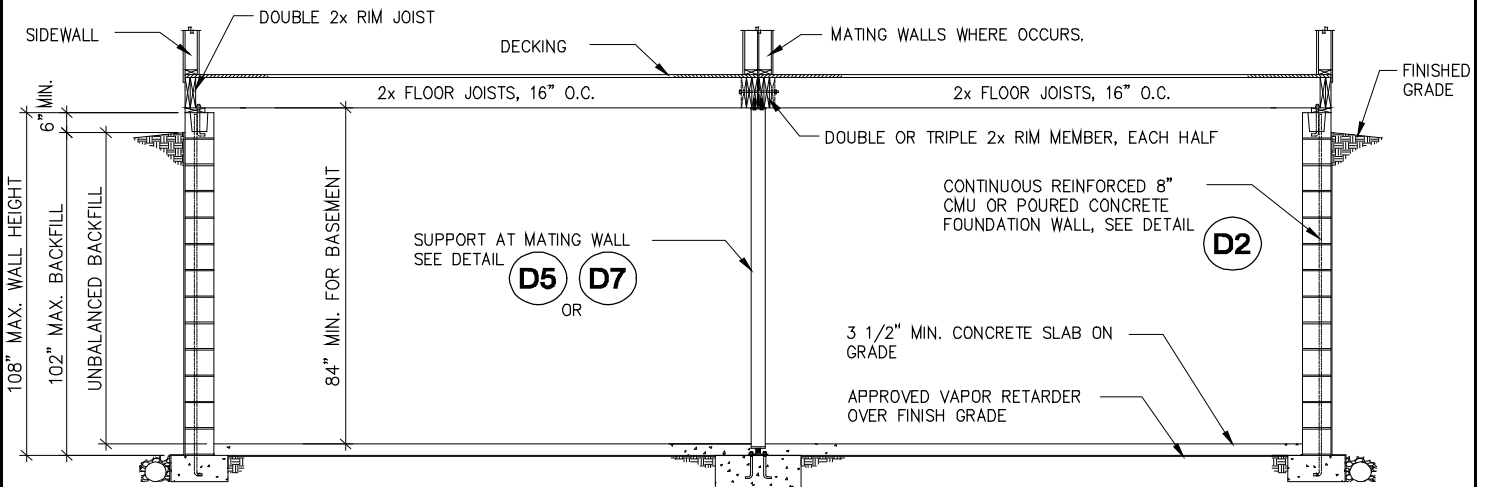

CROSS SECTION A-A

NOTES:

1. MARRIAGE LINE POSTS SHALL SUPPORT THE MARRIAGE WALL, COLUMNS AND STAIR LOADS WHERE OCCURS. REFER TO SPECIFIC FOUNDATION LAYOUT FOR LOCATION INFORMATION.
2. SEE GENERAL NOTES SECTION FOR VENTILATION, DRAINAGE AND OTHER FOUNDATION REQUIREMENTS.

APPROVED BY

 1/10/2019
 Approval of this document does not authorize or approve any deviation or deviations from the requirements of applicable State Laws.
David Richter

Schult

**KEY PLAN 7 - OFF-FRAME /
 BASEMENT / 2 SECTION**

DATE: 05/25/07

958I-14.R.F.I.22.22.117(_)

PAGE #:

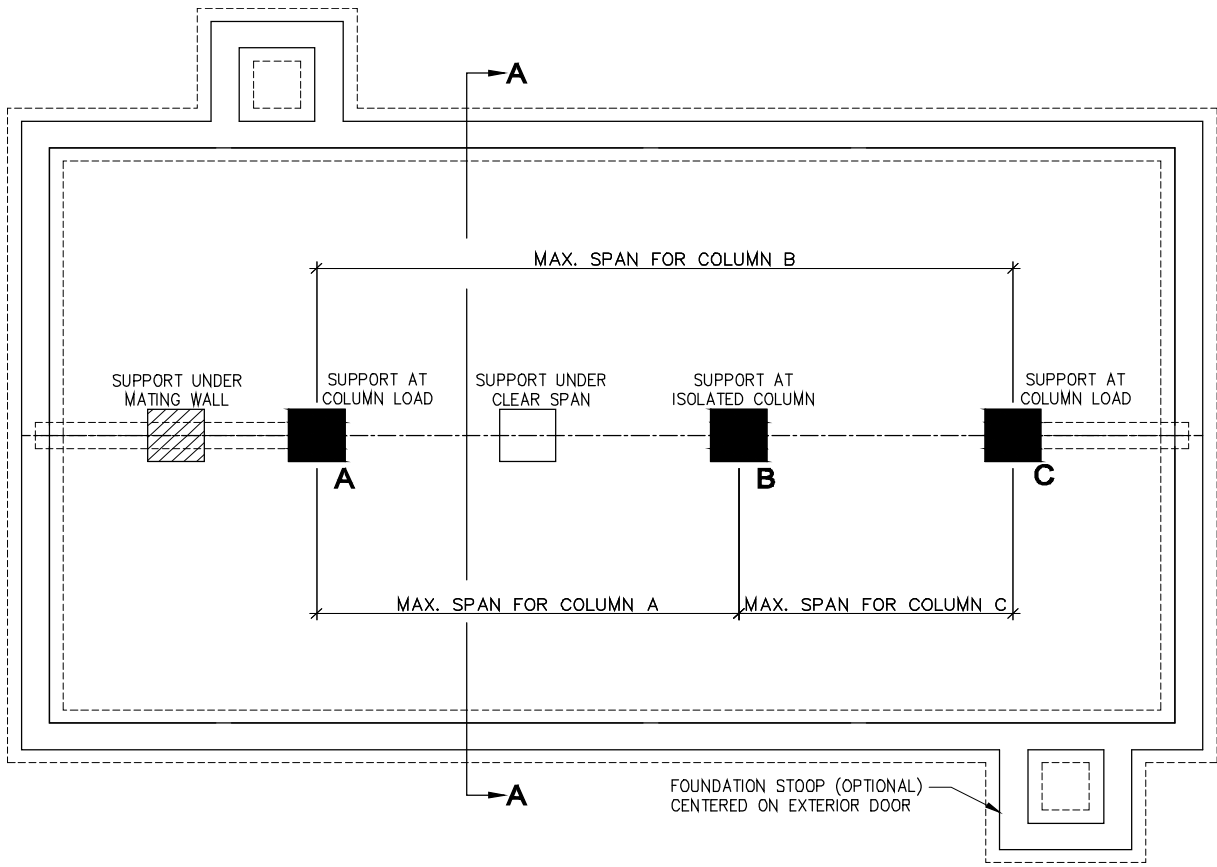

KEY PLAN
OFF-FRAME CRAWL SPACE - 2 SECTION
 NOT TO SCALE

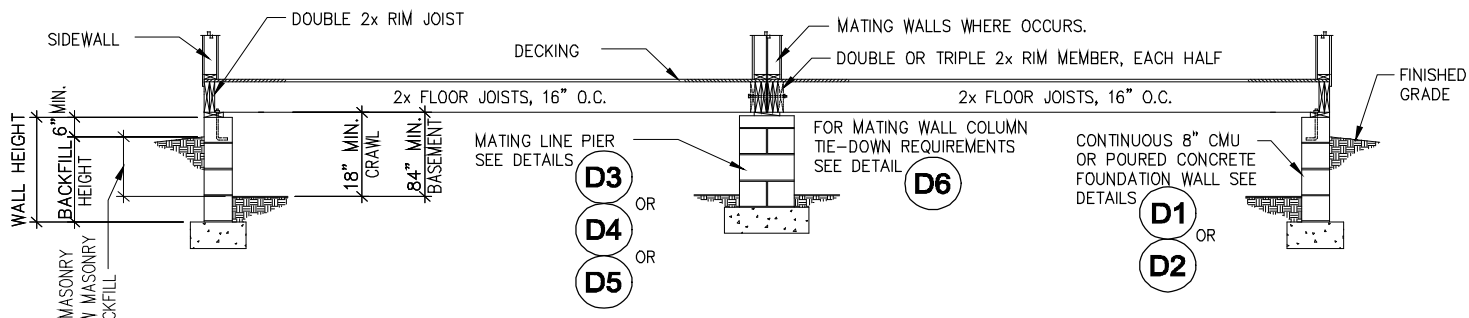

CROSS SECTION A-A

- NOTES:**
1. MARRIAGE LINE POSTS SHALL SUPPORT THE MARRIAGE WALL, COLUMNS AND STAIR LOADS WHERE OCCURS. REFER TO SPECIFIC FOUNDATION LAYOUT FOR LOCATION INFORMATION.
 2. SEE GENERAL NOTES SECTION FOR VENTILATION, DRAINAGE AND OTHER FOUNDATION REQUIREMENTS.

APPROVED BY

 1/10/2019
 Approval of this document does not authorize or approve any deviation or deviations from the requirements of applicable State Laws.
David Richter

Schult

KEY PLAN 8 - OFF-FRAME / CRAWL SPACE / 2 SECTION

DATE: 05/25/07 958I-14.R.F.I.22.22.117(L)

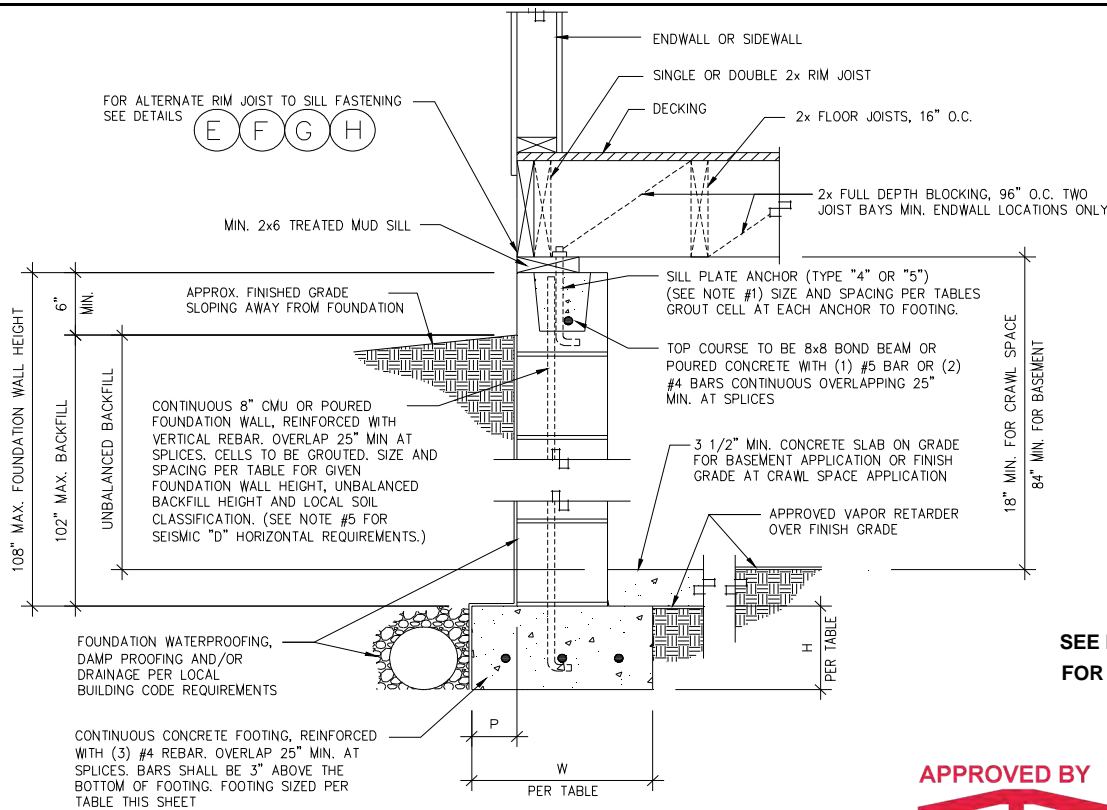

TYPICAL
SEE BELOW FOR ADDITIONAL DETAIL
FOR FOAM SHEATHING APPLICATION



Approval of this document does not authorize or approve any deviation or deviations from the requirements of applicable State Laws.
David Richter

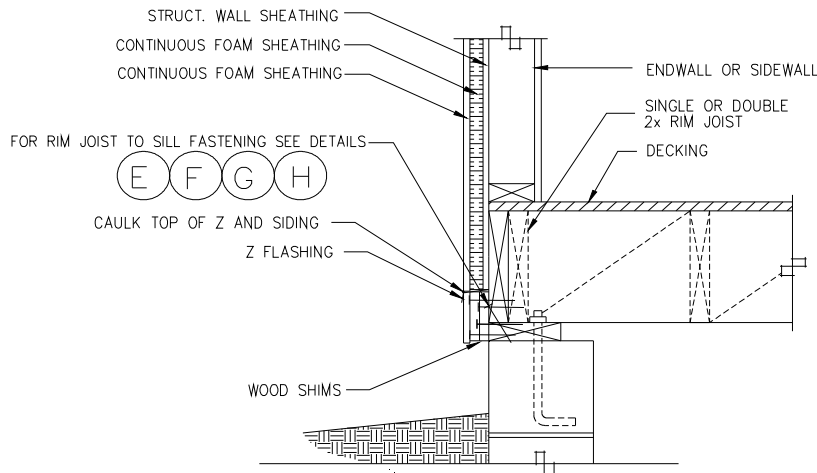

FOOTER SIZE TABLE

MAX. GROUND SNOW	MIN. FOOTER SIZE WIDTH W	DEPTH H	
		Crawl	Basement
20 PSF	16"	6"	6"
30 PSF	16"	6"	6"

REINFORCED PERIMETER FOUNDATION WALL

BASEMENT OR CRAWL SPACE

27' WIDE 1 STORY- W.O ATTIC

155/ 120 *MAXIMUM ULTIMATE/DESIGN WIND SPEED

EXPOSURE C-enclosed & SEISMIC ZONE C

NOTES:

- MUD SILL TO FOUNDATION ANCHORS:
TYPE 4: 1/2" DIAMETER STEEL ANCHOR BOLTS EMBEDDED 7" MIN. INTO CONCRETE FOUNDATION WALL OR CLOSE CELL CMU WITH 2"x2"x1/8" WASHERS AND NUTS. BOLT HEADS SHALL NOT BE RECESSED INTO SINGLE SILL PLATE.
TYPE 5: SIMPSON MAB OR MAS MUD SILL ANCHOR INSTALLED PER INSTALLATION INSTRUCTIONS.
- RIM TO MUD SILL FASTENING AND SILL TO FOUNDATION ANCHOR SPACING SHALL BE THE MINIMUM OF:
a) SPACING GIVEN IN APPLICABLE TABLES FOR UNIT CONFIGURATION AND WIND SPEED.
b) SPACING GIVEN IN BACKFILL/ SIDEWALL TABLES FOR GIVEN UNIT CONFIGURATION, MAXIMUM BASEMENT WALL HEIGHT, BACKFILL DEPTH, AND LOCAL SOIL CLASSIFICATION.
- DISTANCE FROM EDGE OF FOOTER TO FACE OF FOUNDATION WALL (P) SHALL NOT BE LESS THAN 2" AND SHALL NOT EXCEED THE FOOTER THICKNESS (H).
- 2000 PSF MIN. ALLOWABLE SOIL BEARING CAPACITY.
- FOR SEISMIC ZONES EXCEEDING ZONE C:
VERTICALLY REINFORCED PER TABLE (R404.1.1) AT 16" O.C. ALONG ENDWALLS & 48" O.C. ELSEWHERE.

Schult

REINFORCED PERIMETER FOUNDATION WALL - DETAIL - D2

DATE: 06/04/07

958I-14.R.F.I.22.22.117(L)

PAGE #:

1/2" BOLTS, NUTS, AND WASHERS OR 3/8" LAG SCREWS REQUIRED THRU RIM JOIST GIRDER. SIZE AND SPACING PER HOME SETUP MANUAL.

MATING WALLS WHERE OCCURS.

SINGLE, DOUBLE OR TRIPLE 2x RIM MEMBER, EACH HALF

DECKING

2x FLOOR JOISTS, 16" O.C.

FILL ANY GAPS AT BOLT LOCATIONS WITH SOLID WOOD SHIMS FOR WOOD TO WOOD CONTACT.

SHIM AS NEEDED PER NOTE 4

OPTIONAL FILLER PER NOTE 3

CAP BLOCK PER NOTE 3

MATING LINE PIERS LAID IN MORTAR PER NOTE 2. SINGLE, DOUBLE OR TRIPLE STACKED. SIZE AND SPACING REQUIREMENTS PER TABLE "M".

NOTE: FOR COLUMN TIE-DOWN REQUIREMENTS SEE DETAIL (D6)

(D6)

DOUBLE STACKED

APPROVED VAPOR RETARDER OVER FINISH GRADE

67" MAX. ABOVE GRADE

CONCRETE FOOTING BELOW FROST LINE AND MIN. 12" BELOW FINISH GRADE. SIZE PER TABLE "M"

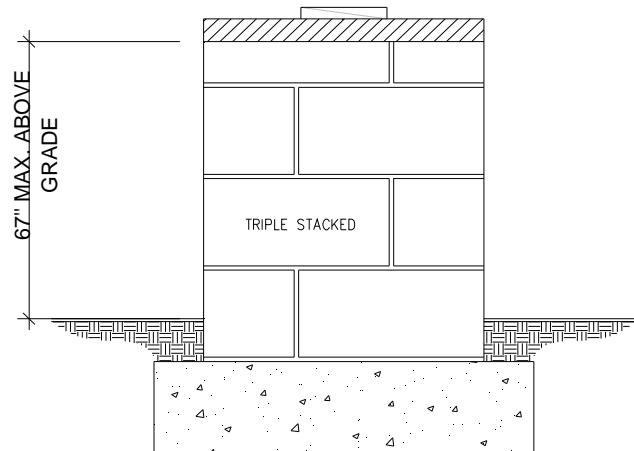
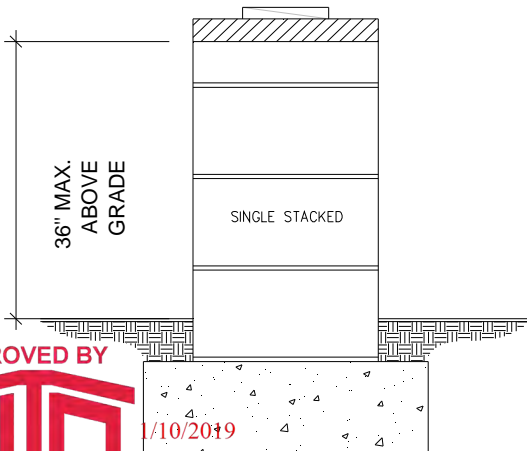

APPROVED BY

NIA INC.
1/10/2019

Approval of this document does not authorize or approve any deviation or deviations from the requirements of applicable State Laws.

David Richter

**NON-REINFORCED MATING WALL OR COLUMN SUPPORT PIER
CRAWL SPACE ONLY**

NOTES:

- FOOTINGS MUST BE LEVEL IN ALL DIRECTIONS. PIERS ARE TO BE PLACED CENTERED ON THE FOOTING SO THAT THE FOOTING PROJECTION FROM THE PIER IS EQUAL FROM SIDE-TO-SIDE AND FRONT-TO-BACK. PIERS MUST BE LEVEL VERTICALLY ON ALL SIDES AND SQUARE WITH THE FOOTING.
- CONCRETE BLOCKS FOR PIERS ARE 8" x 16" x 8" NOMINAL SIZE, HOLLOW CELL LOAD BEARING CMU's MANUFACTURED IN CONFORMANCE WITH ASTM C90, GRADE "N". OPEN CELLS ARE ALIGNED VERTICALLY. THE PIERS SHALL BE LAID IN RUNNING BOND WITH TYPE M OR S MORTAR OR APPROVED ALTERNATE (SEE GENERAL NOTE 12). SINGLE STACKED BLOCKS TO BE LAID WITH LONG SIDE PERPENDICULAR TO MATE LINE RIM JOISTS. DOUBLE STACKED BLOCK IS LAID WITH EACH LAYER AT A RIGHT ANGLE TO THE PREVIOUS LAYER. THE TOP COURSE OR THE CAP BLOCKS SHALL BE PERPENDICULAR TO THE MATE LINE RIM JOISTS.
- CAP BLOCKS SHALL BE 4" SOLID CONCRETE OR MASONRY BLOCK. 2x NOMINAL HARDWOOD OR 1/2" STEEL MAY BE USED AS A CAP BLOCK IF THE TOP COURSE OF THE PIER IS SOLID MASONRY OR CONCRETE OR IF THE TOP COURSE OF A HOLLOW PIER IS FILLED WITH CONCRETE OR GROUT. OPTIONAL FILLER MATERIAL MAY BE 2x NOMINAL HARDWOOD OR 2" OR 4" NOMINAL SOLID CONCRETE BLOCK. ALL CAPS AND FILLER SHALL BE OF THE SAME NOMINAL DIMENSIONS AS THE PIERS THEY REST UPON. INDIVIDUAL LENGTHS OF CAP BLOCKS AND FILLER SHALL BE PERPENDICULAR TO THE MATE LINE RIM JOISTS.
- SHIMS SHALL BE OF HARDWOOD, AT LEAST 3 1/2" WIDE AND 6" LONG AND ARE NOT TO EXCEED ONE INCH IN THICKNESS. SHIMS SHALL BE PERPENDICULAR TO MATE LINE, FITTED AND DRIVEN TIGHT BETWEEN CAP BLOCKS OR FILLER AND MATE LINE RIM JOISTS.
- MARRIAGE LINE PIERS SHALL SUPPORT THE MARRIAGE WALL AND COLUMNS WHERE OCCURS PER MODEL SPECIFIC FOUNDATION PLAN. MAXIMUM PIER SPACING PER TABLE "M".
- SEE GENERAL NOTES FOR DRAINAGE AND OTHER FOUNDATION REQUIREMENTS.

Schult

**NON-REINFORCED MATING
WALL COLUMN SUPPORT
PIER - CRAWLSPACE ONLY -
DETAIL - D3**

DATE: 06/13/07

9581-14.R.F.I.22.22.117(L)

PAGE #:

Page 17 OF 33

1/2" BOLTS, NUTS, AND WASHERS OR 3/8" LAG SCREWS REQUIRED THRU RIM JOIST GIRDER. SIZE AND SPACING PER HOME SETUP MANUAL.

MATING WALLS WHERE OCCURS.

SINGLE, DOUBLE OR TRIPLE 2x RIM MEMBER, EACH HALF.

DECKING

2x FLOOR JOISTS, 16" O.C.

SHIM AS NEEDED PER NOTE 4

OPTIONAL FILLER PER NOTE 3

CAP BLOCK PER NOTE 3

MATING LINE DOUBLE STACKED PIER PER NOTE 2. REINFORCE PIER WITH (4) #4 VERTICAL REBAR. GROUT CELLS SOLID TO FOOTING. SIZE AND SPACING PER TABLE "M".

FINISH GRADE AT CRAWL SPACE APPLICATION

APPROVED VAPOR RETARDER OVER FINISH GRADE

FILL ANY GAPS AT BOLT LOCATIONS WITH SOLID WOOD SHIMS FOR WOOD TO WOOD CONTACT.

NOTE: FOR COLUMN TIE-DOWN REQUIREMENTS SEE DETAIL **D6**

MASONRY JOINT TYPE M OR S MORTAR

3 1/2" MIN. CONCRETE SLAB ON GRADE FOR BASEMENT APPLICATION

APPROVED VAPOR RETARDER

APPROVED BY
NIA 1/10/2019
INC.

Approval of this document does not authorize or approve any deviation or deviations from the requirements of applicable State Laws.

David Richter

MIN. DIAMETER OF BEND SHALL BE 3" AS MEASURED FROM INSIDE OF REINFORCING BARS WITH A 6" LONG MIN. LEG.

108" MAX. ABOVE GRADE

CONCRETE FOOTING BELOW FROST LINE. REINFORCED WITH (3) #4 REBAR EACH WAY. SIZE PER TABLE "M".

6" MIN.

**REINFORCED MATING WALL OR COLUMN SUPPORT PIER
BASEMENT OR CRAWL SPACE
(PIER SPACING AND FOOTER SIZE PER TABLE M)**

NOTES:

1. FOOTINGS MUST BE LEVEL IN ALL DIRECTIONS. PIERS ARE TO BE PLACED CENTERED ON THE FOOTING SO THAT THE FOOTING PROJECTION FROM THE PIER IS EQUAL FROM SIDE-TO-SIDE AND FRONT-TO-BACK. PIERS MUST BE LEVEL VERTICALLY ON ALL SIDES AND SQUARE WITH THE FOOTING.
2. CONCRETE BLOCKS FOR PIERS ARE 8" x 16" x 8" NOMINAL SIZE, HOLLOW CELL LOAD BEARING CMU'S MANUFACTURED IN CONFORMANCE WITH ASTM C90, GRADE "N". OPEN CELLS ARE ALIGNED VERTICALLY. THE PIERS SHALL BE LAID IN RUNNING BOND WITH TYPE M OR S MORTAR. SINGLE STACKED BLOCKS TO BE LAID WITH LONG SIDE PERPENDICULAR TO MATE LINE RIM JOISTS. DOUBLE STACKED BLOCK IS LAID WITH EACH LAYER AT A RIGHT ANGLE TO THE PREVIOUS LAYER. THE TOP COURSE OR THE CAP BLOCKS SHALL BE PERPENDICULAR TO THE MATE LINE RIM JOISTS.
3. CAP BLOCKS SHALL BE 4" SOLID CONCRETE OR MASONRY BLOCK. 2x NOMINAL HARDWOOD OR 1/2" STEEL MAY BE USED AS A CAP BLOCK IF THE TOP COURSE OF THE PIER IS SOLID MASONRY OR CONCRETE OR IF THE TOP COURSE OF A HOLLOW PIER IS FILLED WITH CONCRETE OR GROUT. OPTIONAL FILLER MATERIAL MAY BE 2x NOMINAL HARDWOOD OR 2" OR 4" NOMINAL SOLID CONCRETE BLOCK. ALL CAPS AND FILLER SHALL BE OF THE SAME NOMINAL DIMENSIONS AS THE PIERS THEY REST UPON. INDIVIDUAL LENGTHS OF CAP BLOCKS AND FILLER SHALL BE PERPENDICULAR TO THE MATE LINE RIM JOISTS.
4. SHIMS SHALL BE OF HARDWOOD, AT LEAST 3 1/2" WIDE AND 6" LONG AND ARE NOT TO EXCEED ONE INCH IN THICKNESS. SHIMS SHALL BE PERPENDICULAR TO MATE LINE, FITTED AND DRIVEN TIGHT BETWEEN CAP BLOCKS OR FILLER AND MATE LINE RIM JOISTS.
5. MARRIAGE LINE PIERS SHALL SUPPORT THE MARRIAGE WALL AND COLUMNS WHERE OCCURS PER MODEL SPECIFIC FOUNDATION PLAN. MAXIMUM PIER SPACING PER TABLE "M".
6. SEE GENERAL NOTES FOR DRAINAGE AND OTHER FOUNDATION REQUIREMENTS.

Schult

**REINFORCED MATING WALL OR
COLUMN SUPPORT PIER -
BASEMENT OR CRAWL SPACE
DETAIL - D5**

DATE: 06/04/07

958I-
14.R.F.I.22.22.117()

PAGE #:

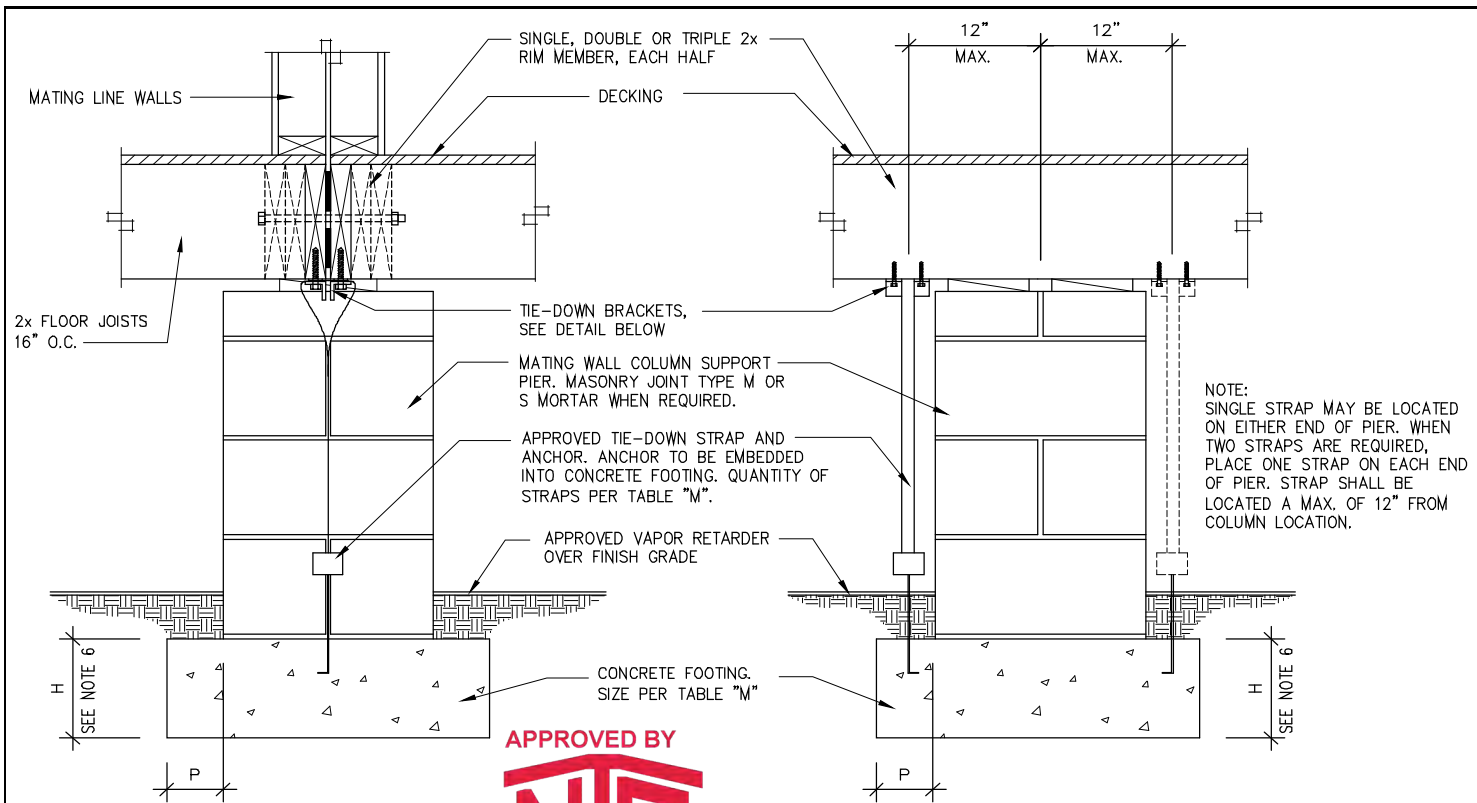

NOTE:
SINGLE STRAP MAY BE LOCATED ON EITHER END OF PIER. WHEN TWO STRAPS ARE REQUIRED, PLACE ONE STRAP ON EACH END OF PIER. STRAP SHALL BE LOCATED A MAX. OF 12" FROM COLUMN LOCATION.

END VIEW

SIDE VIEW

APPROVED BY

 1/10/2019
 Approval of this document does not authorize or approve any deviation or deviations from the requirements of applicable State Laws.
 David Richter

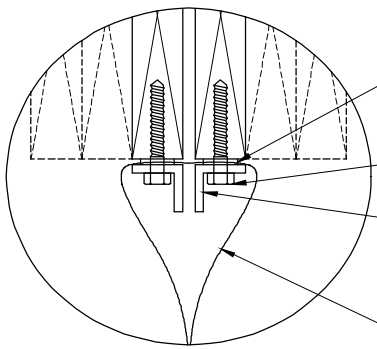
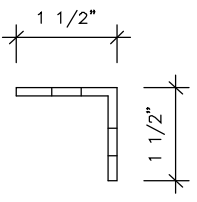
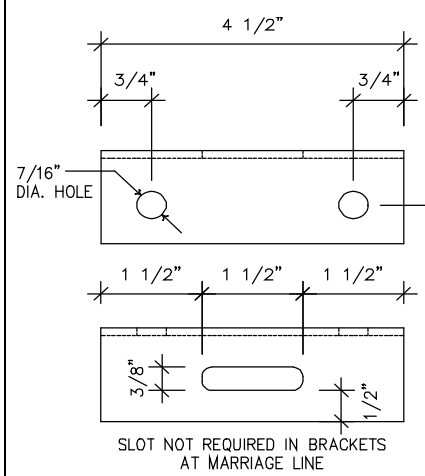

1/8" THICK x 1" WASHERS FOR SPACER BETWEEN BRACKET AND PERIMETER RIM MEMBER AT MATING LINE
 (2) 5/16" x 3" FULL THREAD LAGS AT EACH BRACKET.
 (2) 1 1/2" x 1 1/2" x 4 1/2" LONG x 11 GA. MIN. STEEL ANGLE BRACKETS AT EACH STRAP. INSTALLED WITH "L" FACING OUTSIDE EDGE OF FLOOR SYSTEM
 APPROVED TIE-DOWN STRAP. CAPACITY OF 3,150 LBS. WORKING LOAD (4,725 LBS. ULTIMATE)

TIE-DOWN BRACKETS

MATING WALL COLUMN TIE DOWN

- NOTES:
1. ALL MARRIAGE WALL COLUMN LOCATIONS WITH OPENINGS 4 FEET OR GREATER MAY REQUIRE THE INSTALLATION OF COLUMN BRACKETS AND TIE-DOWNS. SEE TABLE "M" FOR REQUIREMENTS.
 2. EACH BRACKET IS RATED FOR AN ALLOWABLE WORKING LOAD OF 1,719 LBS.
 3. THE CAPACITY OF BOTH THE TIE-DOWN STRAP AND ANCHOR MUST BE 3,150 LBS. WORKING LOAD (4,725 LBS. ULTIMATE)
 4. USE A RADIUS CLIP FOR ALL BRACKET APPLICATIONS BY THREADING A PIECE OF STRAP OVER THE BRACKETS BEFORE LOOPING THE TIE-DOWN STRAP AROUND THE BRACKET.
 5. GROUND ANCHORS WHICH ARE LISTED FOR THE REQUIRED CAPACITY ABOVE MAY BE USED IN LIEU OF CONCRETE ANCHOR.
 6. DISTANCE FROM EDGE OF FOOTING TO FACE OF FOUNDATION WALL (P) SHALL NOT BE LESS THAN 2" AND SHALL NOT EXCEED THE FOOTING THICKNESS (H). FOOTING THICKNESS MAY BE 10" IF GROUND ANCHORS WITH AN UPLIFT CAPACITY OF 3,150 LBS. ARE USED IN PLACE OF CONCRETE ANCHORS.
 7. FOOTING SIZES PER TABLE "M" HAVE BEEN DESIGNED ASSUMING CONCRETE ANCHORS WILL BE UTILIZED. IF GROUND ANCHORS ARE UTILIZED TO TRANSMIT UPLIFT INTO GROUND SOIL, THE DEPTH OF THE FOOTING MAY BE REDUCED TO (P). WHERE (P) IS EQUAL TO THE GREATEST DISTANCE FROM EDGE OF FOOTING TO EDGE OF PIER. MINIMUM DEPTH IS 9".

Schult

MATING WALL COLUMN TIE DOWN - DETAIL - D6

DATE: 06/29/07 9581-14.R.F.I.22.22.117(L)

PAGE #: Page 19 OF 33

1/2" BOLTS, NUTS, AND WASHERS OR 3/8" LAG SCREWS REQUIRED THRU RIM JOIST GIRDER. SIZE AND SPACING PER HOME SETUP MANUAL

MATING WALLS WHERE OCCURS.

SINGLE, DOUBLE OR TRIPLE 2x RIM MEMBER, EACH HALF

DECKING

2x FLOOR JOISTS, 16" O.C.

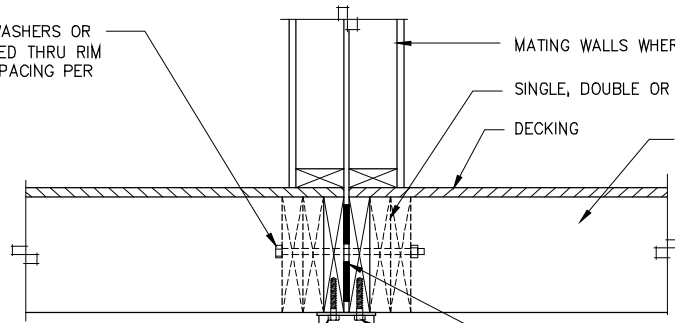

FILL ANY GAPS AT BOLT LOCATIONS WITH SOLID WOOD SHIMS FOR WOOD TO WOOD CONTACT.

(2) 5/16" x 3" LAG SCREWS WITH WASHERS THROUGH POST PLATE INTO RIM JOIST. PILOT HOLES MUST BE SITE DRILLED.

11 GA., 3" DIA. MIN. ADJUSTABLE STEEL MONO POST WITH MIN. 1/4" PLATES TOP AND BOTTOM. SIZE AND SPACING PER TABLE "N".
NOTE: THE MIN. CAPACITY RATING OF EACH POST MUST BE GREATER THAN OR EQUAL TO THE SPECIFIED LOAD CAPACITY OF TABLE "N".

SECURE STEEL POST BOTTOM PLATE TO FOOTING WITH (4) 1/2" DIA. ANCHOR BOLTS OR WEDGE ANCHORS, NUTS AND WASHERS. (UTILIZE 5/8" DIA. ANCHOR BOLTS FOR SEISMIC DESIGN CATEGORY "E" OR HIGHER). MAKE POST ADJUSTMENTS BEFORE POURING SLAB.

APPROVED VAPOR RETARDER

NOTE:
FOR POST SUPPORTING MATING WALL OPENINGS, POST MUST BE RATED AND SECURED TO GIRDER BEAM AND FOOTING FOR UPLIFT FORCE SPECIFIED IN TABLE "N".

3 1/2" MIN. CONCRETE SLAB ON GRADE. IMPORTANT: ALL STEEL POSTS MUST BE INSTALLED AND FINAL ADJUSTMENTS MADE BEFORE SLAB IS POURED. POURED SLAB LOCKS POST ADJUSTMENTS PERMANENTLY.

REINFORCED CONCRETE FOOTING WITH (3) #4 REBARS EACH WAY. SIZE PER TABLE "N".

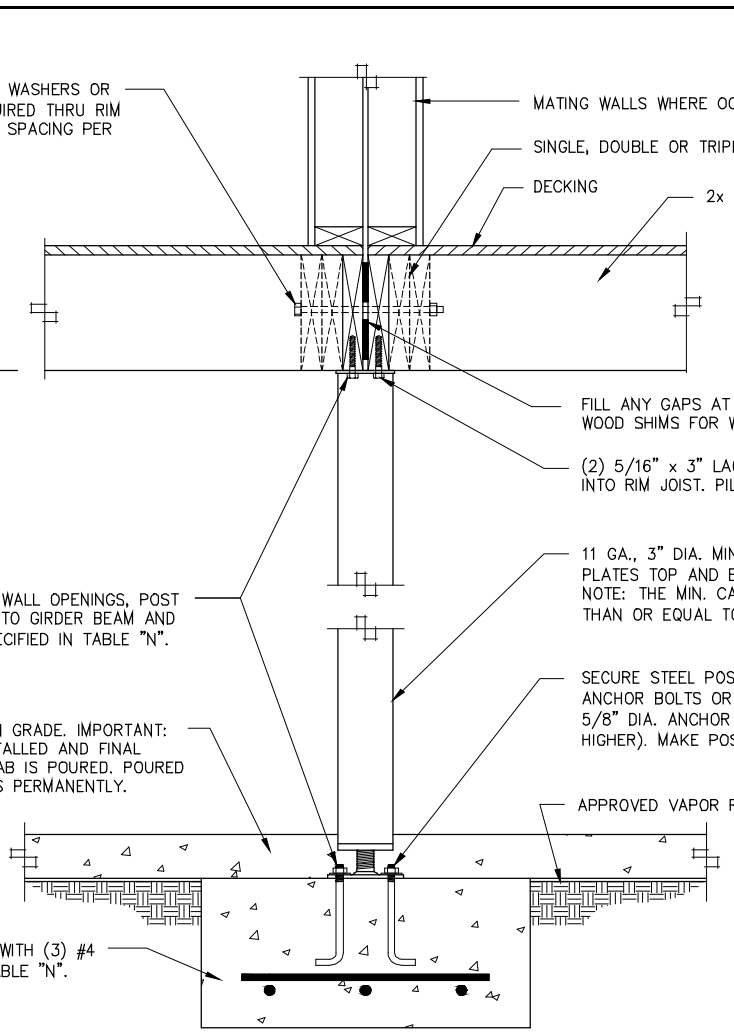

ALTERNATE POST INSTALLATION: STEEL POSTS MAY BE INSTALLED WITH SCREW JACK ASSEMBLY AT THE TOP OR BOTTOM. STEEL POSTS INSTALLED WITHOUT THE SCREW JACK ASSEMBLY AT THE BOTTOM AND ENCASED IN CONCRETE ARE SUBJECT TO LOAD REDUCTIONS. VERIFY THE CAPACITY OF THE STEEL POST BASED ON THE INSTALLATION METHOD PRIOR TO INSTALLATION OF THE POST.



Approval of this document does not authorize or approve any deviation or deviations from the requirements of applicable State Laws.
David Richter

**ADJUSTABLE STEEL COLUMN POST
BASEMENT OR CRAWL SPACE
(MAXIMUM POST SPACING PER TABLE N)**

NOTES:

1. FOOTINGS MUST BE LEVEL IN ALL DIRECTIONS. STEEL POSTS ARE TO BE PLACED CENTERED ON THE FOOTING SO THAT THE FOOTING PROJECTION FROM THE POST IS EQUAL FROM SIDE-TO-SIDE AND FRONT-TO-BACK. COLUMN POSTS MUST BE LEVEL VERTICALLY ON ALL SIDES AND SQUARE WITH THE FOOTING.
2. MARRIAGE LINE STEEL POSTS SHALL SUPPORT THE MARRIAGE WALL AND COLUMNS WHERE OCCURS PER
3. SEE GENERAL NOTES FOR DRAINAGE AND OTHER FOUNDATION REQUIREMENTS.

Schult

**ADJUSTABLE STEEL COLUMN
POST - BASEMENT OR CRAWL
SPACE - DETAIL - D7**

DATE: 06/08/07

958I-14.R.F.I.22.22.117(_)

PAGE #:

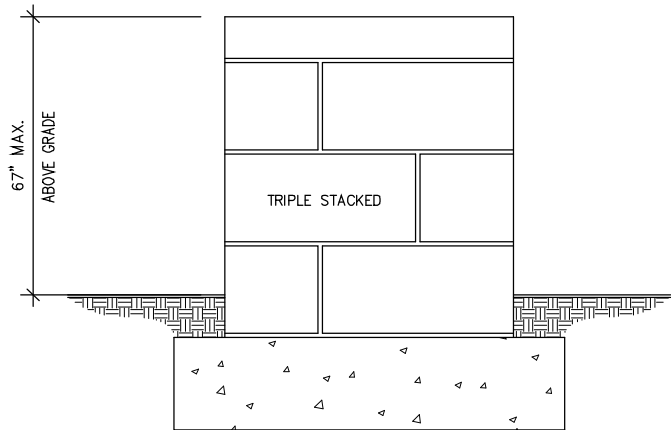
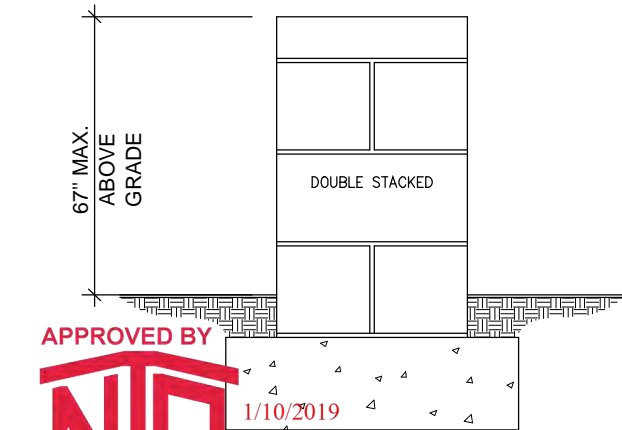
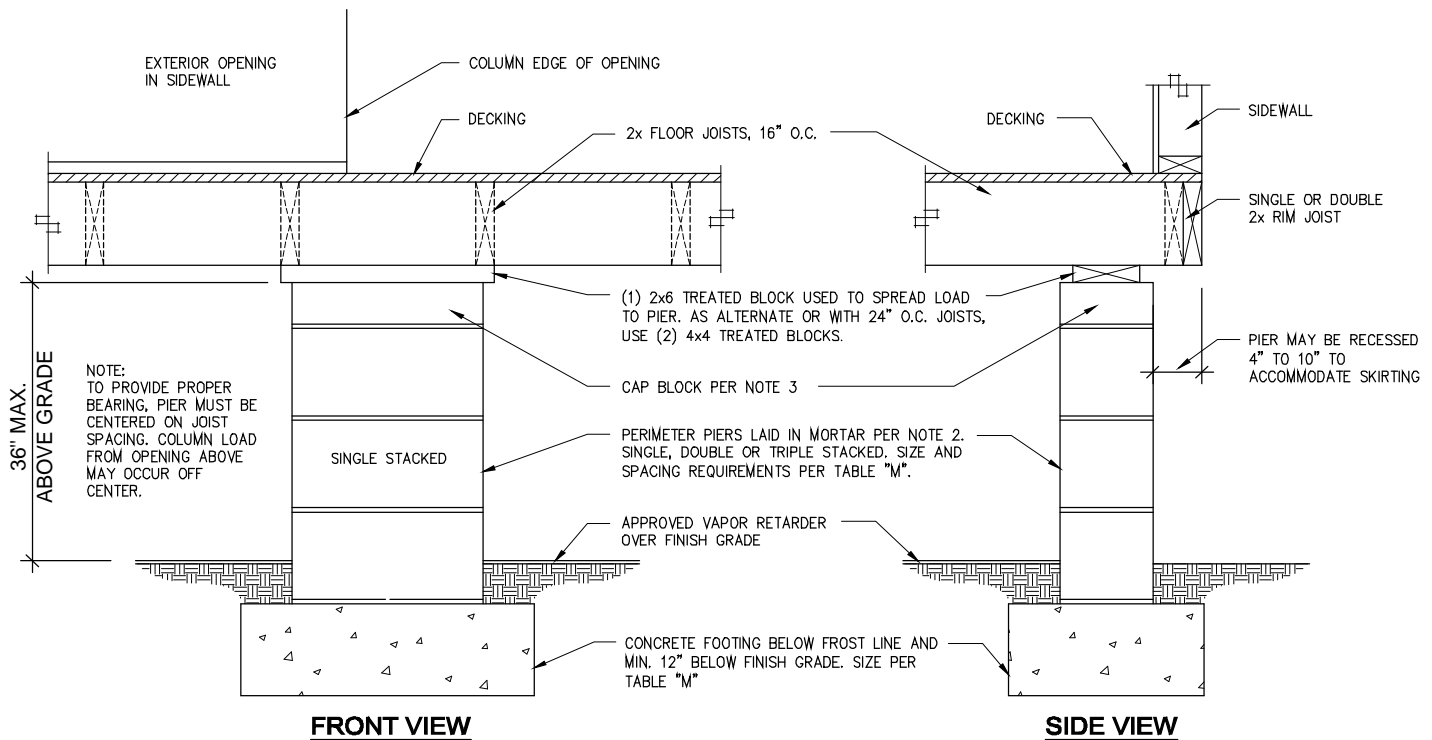

APPROVED BY

 1/10/2019

NON-REINFORCED PERIMETER OR PORCH POST SUPPORT PIER

Approval of this document does not authorize or approve any deviation or deviations from the requirements of applicable State Laws.
David Richter

- NOTES:**
1. FOOTINGS MUST BE LEVEL IN ALL DIRECTIONS. PIERS ARE TO BE PLACED CENTERED ON THE FOOTING SO THAT THE FOOTING PROJECTION FROM THE PIER IS EQUAL FROM SIDE-TO-SIDE AND FRONT-TO-BACK. PIERS MUST BE LEVEL VERTICALLY ON ALL SIDES AND SQUARE WITH THE FOOTING.
 2. CONCRETE BLOCKS FOR PIERS ARE 8" x 16" x 8" NOMINAL SIZE, HOLLOW CELL LOAD BEARING CMU'S MANUFACTURED IN CONFORMANCE WITH ASTM C90, GRADE "N". OPEN CELLS ARE ALIGNED VERTICALLY. SEE NOTE 7. FOR MORTAR REQUIREMENT. SINGLE STACKED BLOCKS TO BE LAID WITH LONG SIDE PERPENDICULAR TO MATE LINE RIM JOISTS. DOUBLE STACKED BLOCK IS LAID WITH EACH LAYER AT A RIGHT ANGLE TO THE PREVIOUS LAYER. THE TOP COURSE OR THE CAP BLOCKS SHALL BE PERPENDICULAR TO THE MATE LINE RIM JOISTS.
 3. CAP BLOCKS SHALL BE 4" SOLID CONCRETE OR MASONRY BLOCK. 2x NOMINAL HARDWOOD OR 1/2" STEEL MAY BE USED AS A CAP BLOCK IF THE TOP COURSE OF THE PIER IS SOLID MASONRY OR CONCRETE OR IF THE TOP COURSE OF A HOLLOW PIER IS FILLED WITH CONCRETE OR GROUT. OPTIONAL FILLER MATERIAL MAY BE 2x NOMINAL HARDWOOD OR 2" OR 4" NOMINAL SOLID CONCRETE BLOCK. ALL CAPS AND FILLER SHALL BE OF THE SAME NOMINAL DIMENSIONS AS THE PIERS THEY REST UPON. INDIVIDUAL LENGTHS OF CAP BLOCKS AND FILLER SHALL BE PERPENDICULAR TO THE MATE LINE RIM JOISTS.
 4. SHIMS SHALL BE OF HARDWOOD, AT LEAST 3 1/2" WIDE AND 6" LONG AND ARE NOT TO EXCEED ONE INCH IN THICKNESS. SHIMS SHALL BE PERPENDICULAR TO MATE LINE, FITTED AND DRIVEN TIGHT BETWEEN CAP BLOCKS OR FILLER AND MATE LINE RIM JOISTS.
 5. MARRIAGE LINE PIERS SHALL SUPPORT THE MARRIAGE WALL AND COLUMNS WHERE OCCURS PER MODEL SPECIFIC FOUNDATION PLAN. MAXIMUM PIER SPACING PER TABLE "M".
 6. SEE GENERAL NOTES FOR DRAINAGE AND OTHER FOUNDATION REQUIREMENTS.

Schult

**NON-REINFORCED PERIMETER/
 PORCH POST SUPPORT PIER -
 DETAIL - D15**

DATE: 07/18/07

9581-14.R.F.1.22.22.117()

PAGE #:

7. THE PIERS SHALL BE LAID IN RUNNING BOND WITH TYPE M OR S MORTAR OR DRY STACKED ABOVE FIRST COARSE WITH SURFACE BONDING AGENT APPLIED THAT MEETS ASTM C887 WHEN ACCEPTABLE TO LOCAL AUTHORITY. BONDING AGENT MUST BE INTENDED FOR USE/APPLICATION AND SHALL BE INSTALLED PER MANUFACTURES SPECIFICATINS.

APPROVED BY
NIA INC. 1/10/2019
 Approval of this document does not authorize or approve any deviation or deviations from the requirements of applicable State Laws.
David Richter

SIMPSON MSTCM40 STRAP OR STHD14 STRAP IS IN ADDITION TO REQUIRED ANCHOR BOLTS AND RIM TO MUD SILL FASTENING REQUIREMENTS. (SEE HOME FLOOR TO SILL PLATE AND SILL PLATE TO FOUNDATION CHARTS FOR NUMBER OF STRAPS REQUIRED AT EACH HOLD-DOWN LOCATION.)

NOTE:
 STRAP MUST BE POSITIONED A MINIMUM OF 1 1/2" FROM EDGE OF FOUNDATION WALL.

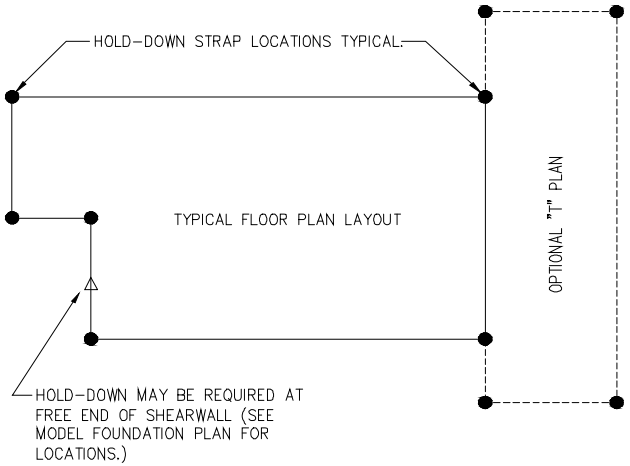
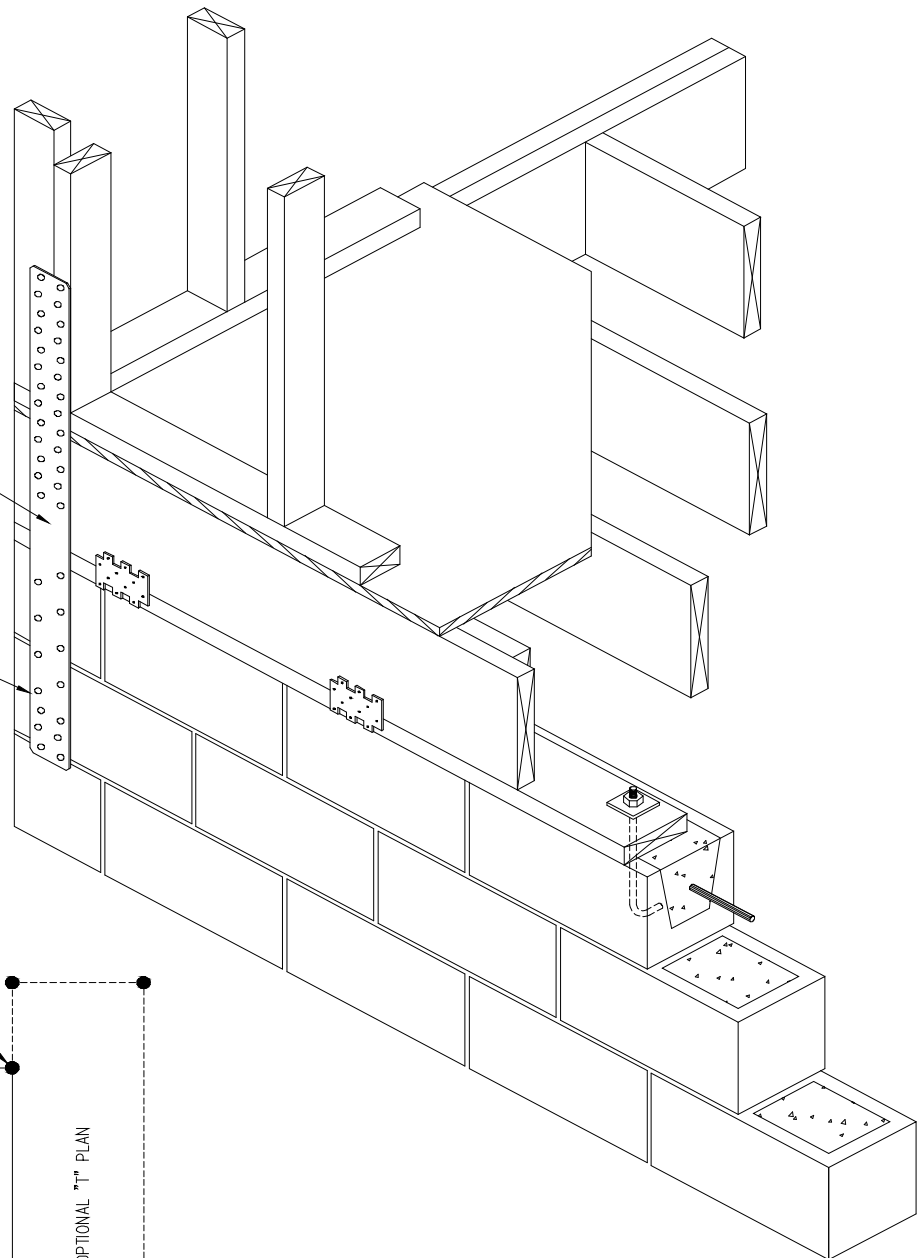

SHEARWALL FOUNDATION HOLD-DOWN

NOTES:

1. WHERE REQUIRED AT FREE-END HOLD-DOWNS (AS LOCATED ON THE FOUNDATION LAYOUT) OR AT BUILDING CORNERS PER THE FASTENING TABLES INCLUDED WITHIN THIS FOUNDATION DESIGN PACKAGE, THE FOUNDATION HOLD-DOWN STRAPS ARE THE RESPONSIBILITY OF OTHERS AND ARE NOT PROVIDED BY CLAYTON HOME BUILDING GROUP OR SUBSIDIARIES.
2. SIMPSON MSTCM40 SHALL BE FASTENED TO WALL STUD WITH (26) 16d NAILS AND TO FOUNDATION WALL WITH (14) 1/4" x 2 1/4" TITAN SCREWS.
3. SIMPSON MSTCM40 OR STHD14 STRAP MAY BE PLACED ON ENDWALL OR SIDEWALL. MINIMUM EDGE DISTANCE OF TITAN SCREW TO CONCRETE OR MASONRY BLOCK CORNER OF 1 1/2" MUST BE MAINTAINED.
4. SIMPSON MSTCM40 STRAP IS IN ADDITION TO THE REQUIRED ANCHOR BOLTS AND RIM TO MUD SILL FASTENING REQUIREMENTS.
5. SIMPSON STHD14 STRAP (POURED WALLS) MUST BE FASTENED TO WALL STUD WITH (38) .148X 3 1/4" NAILS.)
6. DESIGN STRAP CAPACITY: MSTCM40=4250# AND STHD14= 5025#

Schult

SHEARWALL FOUNDATION HOLD-DOWN - DETAIL - D18

DATE: 06/13/07 958I-14.R.F.I.22.22.117(_)

PAGE #: **Page 22 OF 33**

WHEN FASTENING TABLES WITH H PLATES ARE USED SIMPSON LTP4 SHALL BE INSTALLED PER DETAIL H. TO BOTH BOTTOM MUD SILL TO UPPER MUD SILL & TOP MUD SILL TO RIM JOIST. SPACING PER HOME FLOOR TO SILL PLATE & SILL WITH H PLATE TABLES.

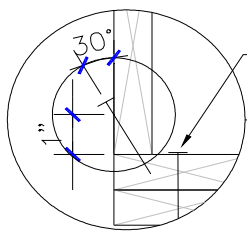
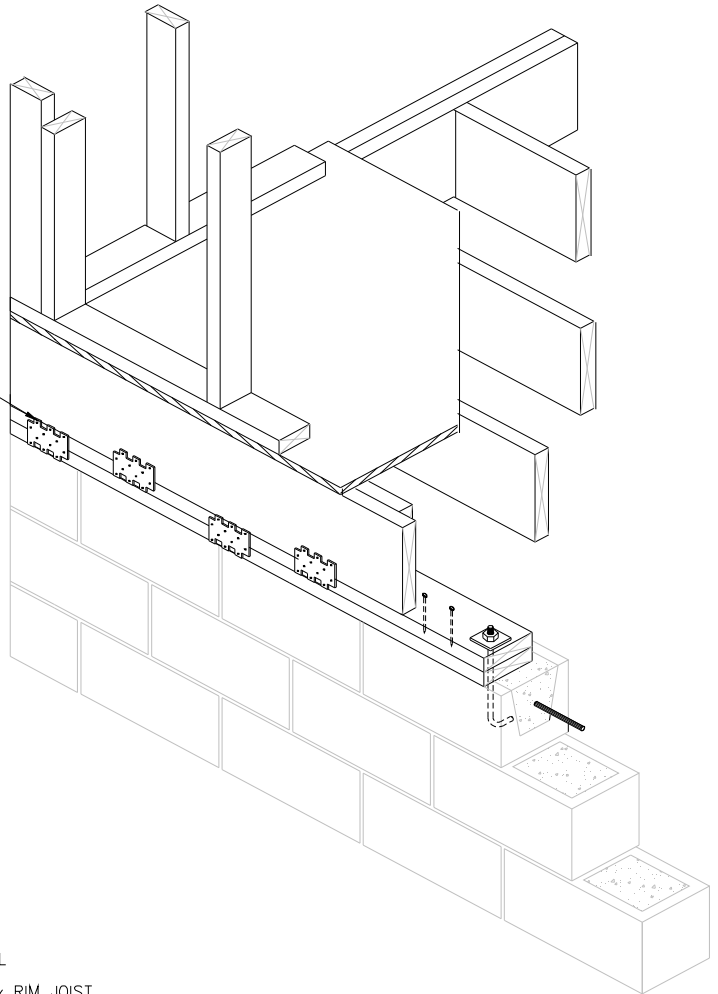

FASTEN UPPER TOP PLATE TO BOTTOM PLATE WITH 8D (.131 x 3") NAILS SPACED PER TYPE E FASTENER TYPE SPACING FOR RIM TO SILL

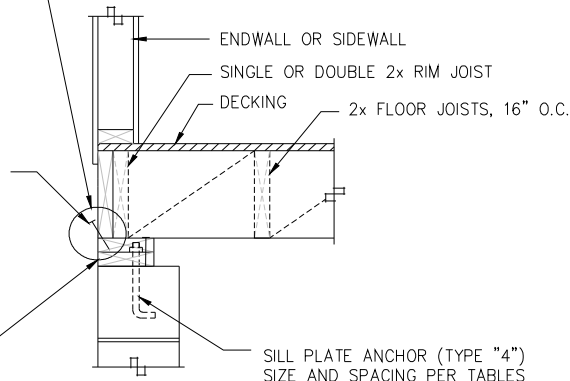

FASTEN RIM JOIST TO SILL WITH 10D (.148 x 3") CORROSION RESISTANT NAILS. ON CENTER SPACING OF FASTENER TYPE "E" IN TABLES. NOTE: IF SPACING REQUIRES ADDITIONAL TYPE "H" PLATE CONNECTORS, SEE DETAIL ABOVE AND DETAIL (H)

MIN. 2x6 TREATED MUD SILLS TOP PLATE ONLY MAY BE NOTCHED OR COUNTER SUNK. TO RECEIVE NUTS/ WASHERS.

SILL PLATE ANCHOR (TYPE "4") SIZE AND SPACING PER TABLES

APPROVED BY



Approval of this document does not authorize or approve any deviation or deviations from the requirements of applicable State Laws.

David Richter

DOUBLE MUD SILL OPTION

NOTES:

1. MUD SILL TO FOUNDATION ANCHORS:
TYPE 4: 1/2" DIAMETER STEEL ANCHOR BOLTS EMBEDDED 7" MIN. INTO CONCRETE FOUNDATION WALL OR CLOSE CELL CMU WITH 2"x2"x1/8" WASHERS AND NUTS. BOLT HEADS SHALL NOT BE RECESSED INTO BOTTOM MUD SILL PLATE.
2. UPPER MUD SILL MUST BE FASTENED TO LOWER MUD SILL WITH .131"x3" NAILS SPACED PER RIM JOIST TO MUD SILL SPACING TABLE FOR TYPE E FASTENERS.
4. WHEN FASTENING TABLES WITH H PLATES ARE USED, SIMPSON LPT4 PLATES MUST BE INSTALLED FROM LOWER MUD SILL TO UPPER MUD SILL AND FROM UPPER MUD SILL TO RIM JOIST PER FASTENING SPACED PER RIM TO MUD SILL SPACING TABLES.

Schult

DOUBLE MUD SILL FOUNDATION WALL DETAIL - D34

DATE: 06/04/07

I-14.R.CC.I.42.0.117

PAGE #:

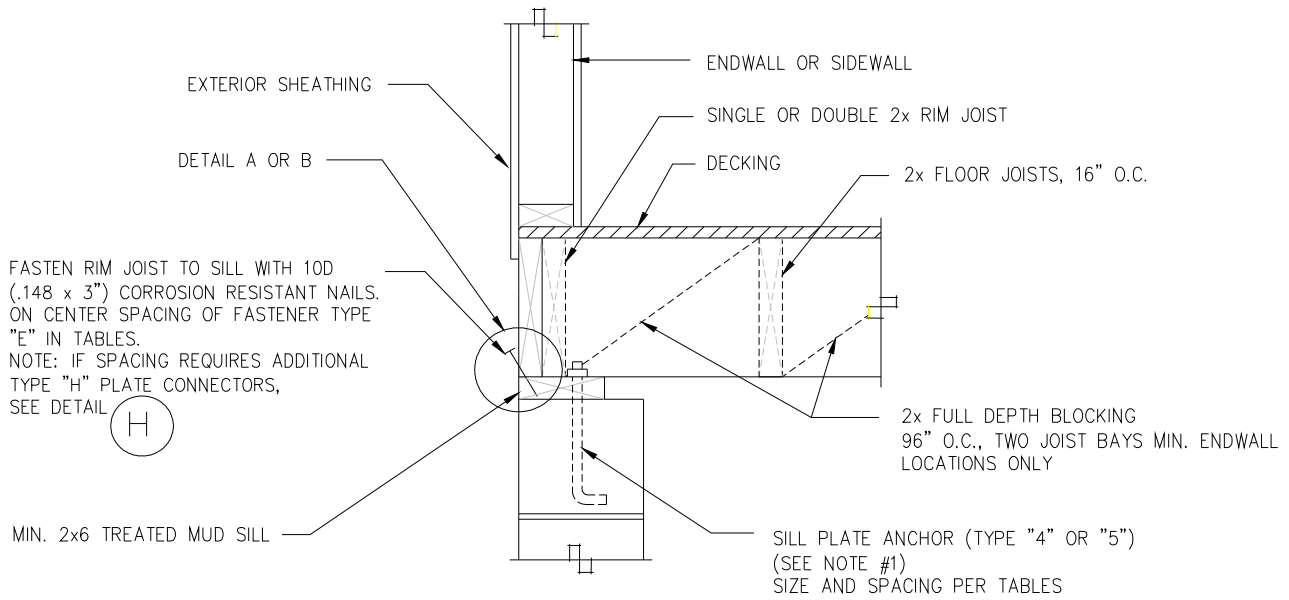

FASTEN RIM JOIST TO SILL WITH 10D (.148 x 3") CORROSION RESISTANT NAILS. ON CENTER SPACING OF FASTENER TYPE "E" IN TABLES.
 NOTE: IF SPACING REQUIRES ADDITIONAL TYPE "H" PLATE CONNECTORS, SEE DETAIL **(H)**

MIN. 2x6 TREATED MUD SILL

2x FULL DEPTH BLOCKING
 96" O.C., TWO JOIST BAYS MIN. ENDWALL LOCATIONS ONLY

SILL PLATE ANCHOR (TYPE "4" OR "5")
 (SEE NOTE #1)
 SIZE AND SPACING PER TABLES

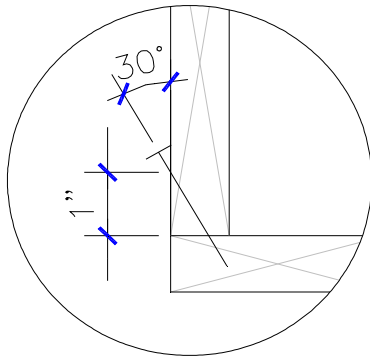

ALTERNATE FASTENER:

THE FOLLOWING ALTERNATE FASTENERS MAY BE USED WHEN SPACING IN CHART IS MULTIPLIED BY THE FOLLOWING FASTENER MULTIPLIER.

- 8D (.131 x 3") NAIL = .82
- 16D (.162 x 3 1/2") NAIL = 1.2
- #8 x 3" WOOD SCREW = .78

APPROVED BY

 1/10/2019
 Approval of this document does not authorize or approve any deviation or deviations from the requirements of applicable State Laws.
 David Richter

FASTENED THRU $\frac{7}{16}$ " MAX. EXTERIOR SHEATHING

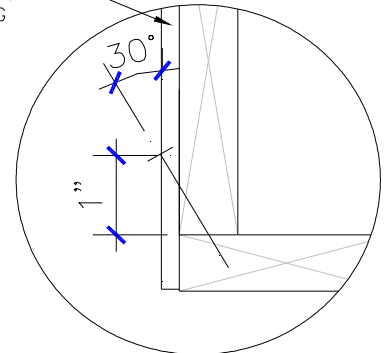

ALTERNATE FASTENER:

- FASTENERS MAY BE INSTALLED THROUGH $\frac{7}{16}$ " MAXIMUM THICK WALL SHEATHING WHEN SPACING IN CHARTS ARE REDUCED BY MULTIPLYING BY THE FOLLOWING:
- 10d (.148"x3") NAIL = .68
 - 8D (.131 x 3") NAIL = .55
 - 16D (.162 x 3 1/2") NAIL = .816
 - #8 x 3" WOOD SCREW = .53

DETAIL A- DIRECT RIM TO SILL FASTENING

DETAIL B- THRU SHEATHING RIM TO SILL FASTENING

FLOOR TO SILL PLATE FASTENING -TYPE "E" -ENDWALL OR SIDEWALL

NOTES:

- 1) MUD SILL TO FOUNDATION ANCHORS:
 TYPE 4: DIAMETER STEEL ANCHOR BOLTS EMBEDDED 7" MIN. INTO CONCRETE FOUNDATION WALL OR CLOSE CELL CMU WITH WASHERS AND NUTS. BOLT HEADS SHALL NOT BE RECESSED INTO SINGLE SILL PLATE.
 TYPE 5: SIMPSON MAB OR MASA MUD SILL ANCHOR INSTALLED PER INSTALLATION INSTRUCTIONS
- 2) RIM TO MUD SILL FASTENING AND SILL TO FOUNDATION ANCHOR SPACING SHALL BE THE MINIMUM OF:
 - a) SPACING GIVEN IN APPLICABLE TABLES FOR UNIT CONFIGURATION AND WIND SPEED.
 - b) SPACING GIVEN IN BACKFILL/ SIDEWALL TABLES FOR GIVEN UNIT CONFIGURATION, MAXIMUM BASEMENT WALL HEIGHT, BACKFILL DEPTH, AND LOCAL SOIL CLASSIFICATION.

Schult

FLOOR TO SILL PLATE FASTENING - ENDWALL OR SIDEWALL - DETAIL - E

DATE: 04/17/07

958I-14.R.F.I.22.22.117(_)

PAGE #:

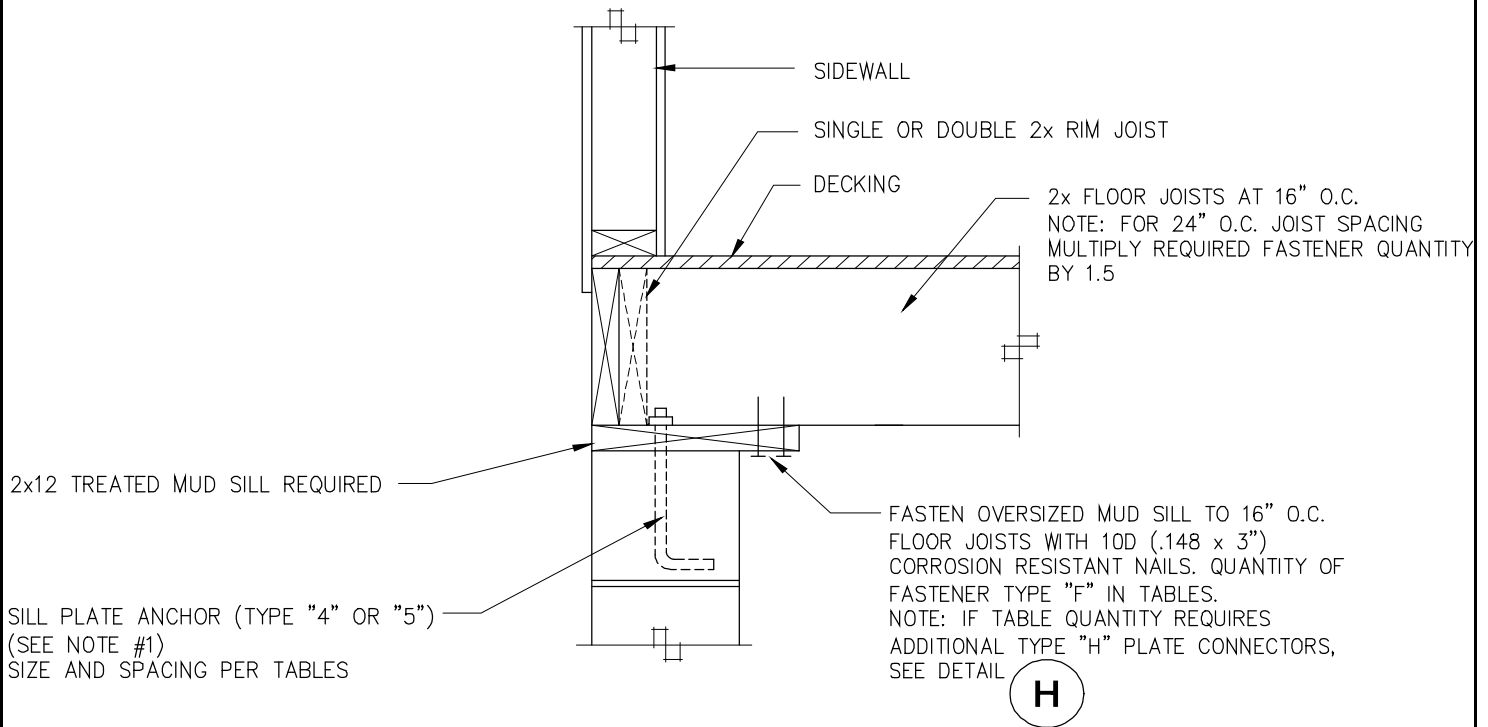

APPROVED BY

 1/10/2019
David Richter

Approval of this document does not authorize or approve any deviation or deviations from the requirements of applicable State Laws.

ALTERNATE FASTENERS:
 THE FOLLOWING ALTERNATE FASTENERS MAY BE USED WHEN QUANTITY IN TABLE IS MULTIPLIED BY THE FOLLOWING FASTENER MULTIPLIER.

8D (.131 x 3") NAIL = 1.21
 16D (.162 x 3 1/2") NAIL = .83
 #8 x 3" WOOD SCREW = 1.28

NOTE: THIS DETAIL FOR TYPE "F" FASTENING IS APPLICABLE TO SIDEWALL CONNECTIONS ONLY AND CAN NOT BE USED FOR ENDWALLS. SEE FASTENING TYPE "E" OR TYPE "G" FOR ENDWALL APPLICATION.

FLOOR TO SILL PLATE FASTENING - TYPE "F" - SIDEWALL ONLY

NOTES:

- 1) MUD SILL TO FOUNDATION ANCHORS:
 TYPE 4: DIAMETER STEEL ANCHOR BOLTS EMBEDDED 7" MIN. INTO CONCRETE FOUNDATION WALL OR CLOSE CELL CMU WITH WASHERS AND NUTS. BOLT HEADS SHALL NOT BE RECESSED INTO SINGLE SILL PLATE.
 TYPE 5: SIMPSON MAB OR MASA MUD SILL ANCHOR INSTALLED PER INSTALLATION INSTRUCTIONS
- 2) RIM TO MUD SILL FASTENING AND SILL TO FOUNDATION ANCHOR SPACING SHALL BE THE MINIMUM OF:
 - a) SPACING GIVEN IN APPLICABLE TABLES FOR UNIT CONFIGURATION AND WIND SPEED.
 - b) SPACING GIVEN IN BACKFILL/ SIDEWALL TABLES FOR GIVEN UNIT CONFIGURATION, MAXIMUM BASEMENT WALL HEIGHT, BACKFILL DEPTH, AND LOCAL SOIL CLASSIFICATION.

Schult

FLOOR TO SILL PLATE FASTENING - SIDEWALL ONLY DETAIL - F

DATE: 04/17/07

958I-14.R.F.I.22.22.117(_)

PAGE #:

Page 25 OF 33

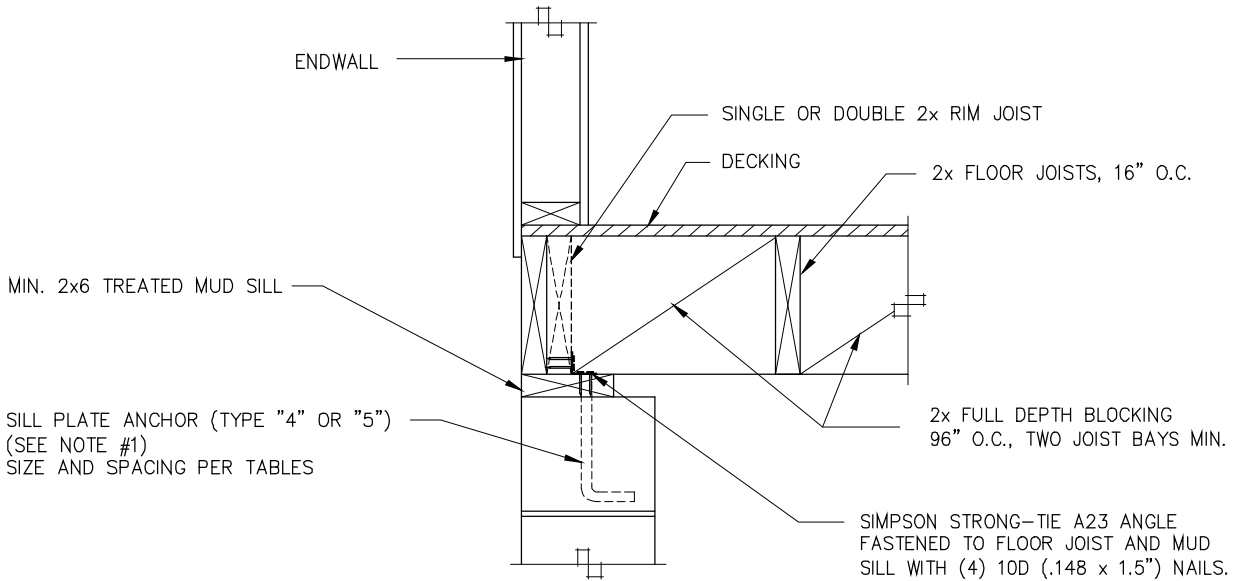

ENDWALL DETAIL

SIMPSON STRONG-TIE A23 ANGLE FASTENED TO FLOOR JOIST AND MUD SILL WITH (4) 10D (.148 x 1.5") NAILS. (CORROSION RESISTANT NAIL REQUIRED INTO P.T. MUD SILL) O.C. SPACING PER FASTENER TYPE "G" IN TABLES. NOTE: IF SPACING REQUIRES ADDITIONAL TYPE "H" PLATE CONNECTORS, SEE DETAIL



APPROVED BY

 1/10/2019
 Approval of this document does not authorize or approve any deviation or deviations from the requirements of applicable State Laws.
 David Richter

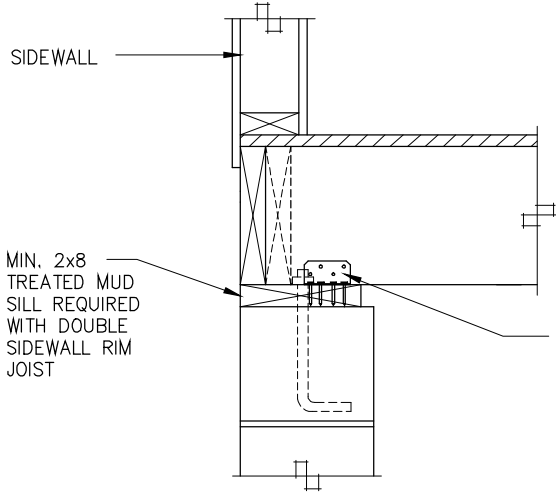

SIDEWALL DETAIL

SIMPSON STRONG-TIE A23 ANGLE FASTENED TO FLOOR JOIST AND MUD SILL WITH (4) 10D (.148 x 1.5") NAILS. (CORROSION RESISTANT NAIL REQUIRED INTO P.T. MUD SILL) USE (1) OR (2) ANGLES EA. JOIST PER FASTENER TYPE "G" IN TABLES. NOTE: IF SPACING REQUIRES ADDITIONAL TYPE "H" PLATE CONNECTORS, SEE DETAIL

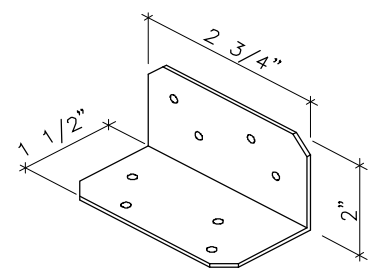

SIMPSON STRONG-TIE 'A23' ANGLE

FLOOR TO SILL PLATE FASTENING - TYPE "G" -ENDWALL OR SIDEWALL

<p>NOTES:</p> <p>1) MUD SILL TO FOUNDATION ANCHORS: TYPE 4: DIAMETER STEEL ANCHOR BOLTS EMBEDDED 7" MIN. INTO CONCRETE FOUNDATION WALL OR CLOSE CELL CMU WITH WASHERS AND NUTS. BOLT HEADS SHALL NOT BE RECESSED INTO SINGLE SILL PLATE. TYPE 5: SIMPSON MAB OR MASA MUD SILL ANCHOR INSTALLED PER INSTALLATION INSTRUCTIONS</p> <p>2) RIM TO MUD SILL FASTENING AND SILL TO FOUNDATION ANCHOR SPACING SHALL BE THE MINIMUM OF: a) SPACING GIVEN IN APPLICABLE TABLES FOR UNIT CONFIGURATION AND WIND SPEED. b) SPACING GIVEN IN BACKFILL/ SIDEWALL TABLES FOR GIVEN UNIT CONFIGURATION, MAXIMUM BASEMENT WALL HEIGHT, BACKFILL DEPTH, AND LOCAL SOIL CLASSIFICATION.</p>	Schult	
	FLOOR TO SILL PLATE FASTENING - ENDWALL OR SIDEWALL - <u>DETAIL - G</u>	
	DATE: 05/25/07	958I-14.R.F.I.22.22.117(_)
PAGE #:	Page 26 OF 33	

SIMPSON STRONG-TIE LPT4 OR TP35 TIE PLATE FASTENED TO RIM JOIST AND MUD SILL WITH (12) 8D (.131 x 1.5") NAILS. CORROSION RESISTANT NAILS REQUIRED INTO P.T. MUD SILL.

QUANTITY, LOCATION AND O.C. SPACING PER NOTES 6 OR 7 IN TABLES.

NOTE: USE OF TIE PLATES IS FOR WIND LOAD ONLY AND MUST BE IN ADDITION TO FASTENING REQUIRED FOR BACKFILL PRESSURE PER DETAILS

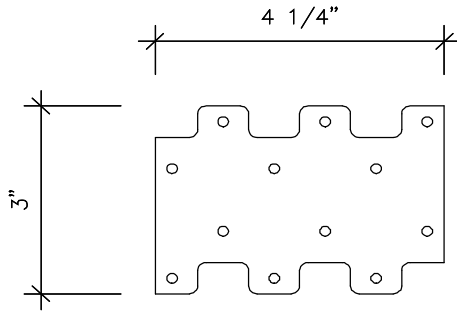
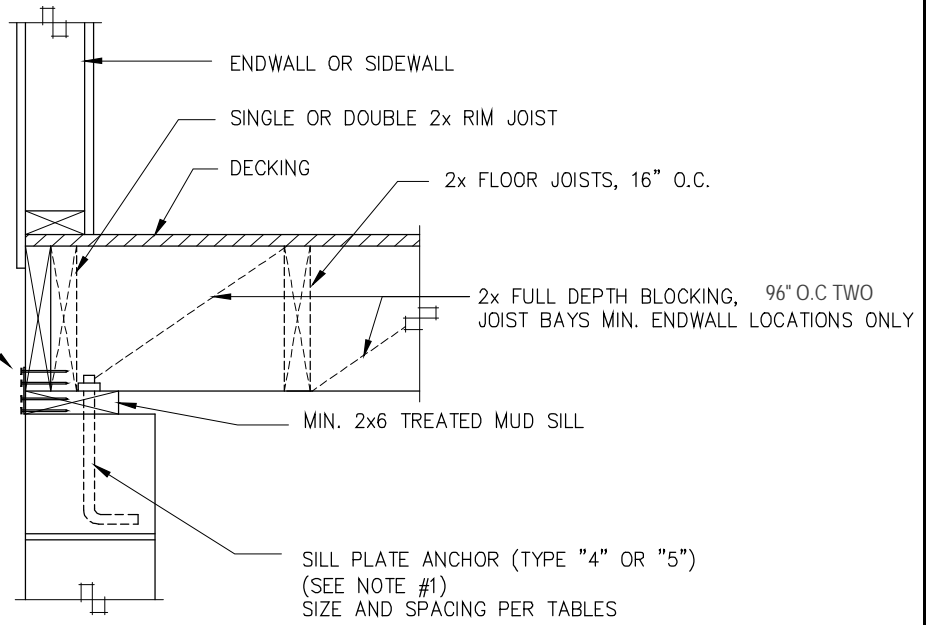

SIMPSON STRONG-TIE "LPT4" TIE PLATE

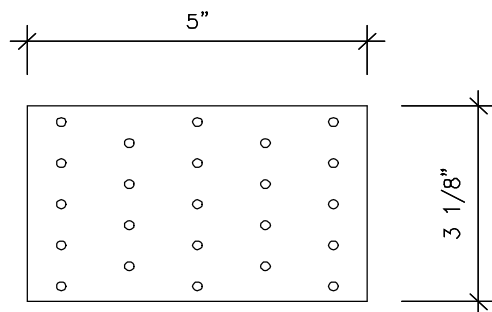

SIMPSON STRONG-TIE "TP35" TIE PLATE

APPROVED BY
NIA 1/10/2019
INC.
 Approval of this document does not authorize or approve any deviation or deviations from the requirements of applicable State Laws.
 David Richter

FLOOR TO SILL PLATE FASTENING - TYPE "H" - ENDWALL OR SIDEWALL

<p>NOTES:</p> <p>1) MUD SILL TO FOUNDATION ANCHORS: TYPE 4: DIAMETER STEEL ANCHOR BOLTS EMBEDDED 7" MIN. INTO CONCRETE FOUNDATION WALL OR CLOSE CELL CMU WITH WASHERS AND NUTS. BOLT HEADS SHALL NOT BE RECESSED INTO SINGLE SILL PLATE. TYPE 5: SIMPSON MAB OR MASA MUD SILL ANCHOR INSTALLED PER INSTALLATION INSTRUCTIONS</p> <p>2) RIM TO MUD SILL FASTENING AND SILL TO FOUNDATION ANCHOR SPACING SHALL BE THE MINIMUM OF: a) SPACING GIVEN IN APPLICABLE TABLES FOR UNIT CONFIGURATION AND WIND SPEED. b) SPACING GIVEN IN BACKFILL/ SIDEWALL TABLES FOR GIVEN UNIT CONFIGURATION, MAXIMUM BASEMENT WALL HEIGHT, BACKFILL DEPTH, AND LOCAL SOIL CLASSIFICATION.</p>	<p>Schult</p>
<p>FLOOR TO SILL PLATE FASTENING - ENDWALL OR SIDEWALL - <u>DETAIL - H</u></p>	
<p>DATE: 04/17/07</p>	<p>958I-14.R.F.I.22.22.117()</p>
<p>PAGE #: Page 27 OF 33</p>	

Home Floor to Sill Plate & Sill Plate to Foundation WITH TYPE H PLATE CONNECTORS (See note 6 & 7) SOIL CLASSES GW, GP, SW AND SP SOILS

Unit Width: 26.67' to 26.67' Max.

Unit Length: 72' Max.

Roof Pitch: 3/12 to 6/12

Max. Roof Overhang: 12 "

Max. Sidewall Height: 9 '

*Wind Speed (3s): 120

Seismic Zone C



Foundation Wall ¹⁰		MAXIMUM FASTENER SPACING OR FASTENERS PER JOIST SPACING ^{2,3 & 5}										# REQ'D S/W HDS SEE D18 /CORNER
		SIDEWALL FASTENING SPACING ¹					END WALL FASTENING					
		Rim to Sill ⁶			Sill to Fnd. Wall		Rim to Sill ⁷		Sill to Fnd. Wall			
Wall Height	Backfill Depth	Fastener Type			Anchor Spacing		Fastener Type		Anchor Spacing			
		E	F ⁴	G ⁴	4	5	E	G	4	5		
24 "	16 "	10.5" o.c.	1	1	72" o.c.	72" o.c.	80" o.c.	269" o.c.	42" o.c.	22" o.c.	1	
32 "	24 "	16.8" o.c.	1	1	72" o.c.	72" o.c.	32" o.c.	106" o.c.	42" o.c.	22" o.c.	1	
40 "	32 "	16.7" o.c.	1	1	72" o.c.	72" o.c.	17" o.c.	56" o.c.	41" o.c.	22" o.c.	1	
3.833 '	3.33 '	9.9" o.c.	1	1	72" o.c.	70" o.c.	10" o.c.	33" o.c.	40" o.c.	22" o.c.	1	
7 '	4 '	10.4" o.c.	1	1	72" o.c.	72" o.c.	10" o.c.	35" o.c.	40" o.c.	22" o.c.	1	
7 '	5 '	5.3" o.c.	2	1	48" o.c.	45" o.c.	5" o.c.	18" o.c.	34" o.c.	21" o.c.	1	
7 '	6 '	3.1" o.c.	3	1	27" o.c.	28" o.c.	3" o.c.	10" o.c.	25" o.c.	18" o.c.	0	
8 '	4 '	11.9" o.c.	1	1	72" o.c.	72" o.c.	12" o.c.	40" o.c.	40" o.c.	22" o.c.	1	
8 '	5 '	6.1" o.c.	2	1	56" o.c.	50" o.c.	6" o.c.	20" o.c.	36" o.c.	21" o.c.	1	
8 '	6 '	3.5" o.c.	3	1	31" o.c.	32" o.c.	4" o.c.	12" o.c.	28" o.c.	19" o.c.	1	
8 '	7 '	NA	5	1	19" o.c.	21" o.c.	NA	7" o.c.	19" o.c.	16" o.c.	0	
9 '	3 '	16.8" o.c.	1	1	72" o.c.	72" o.c.	32" o.c.	106" o.c.	42" o.c.	22" o.c.	1	
9 '	4 '	13.4" o.c.	1	1	72" o.c.	72" o.c.	13" o.c.	45" o.c.	41" o.c.	22" o.c.	1	
9 '	5 '	6.8" o.c.	2	1	64" o.c.	55" o.c.	7" o.c.	23" o.c.	37" o.c.	21" o.c.	1	
9 '	6 '	4.0" o.c.	3	1	35" o.c.	35" o.c.	4" o.c.	13" o.c.	30" o.c.	19" o.c.	1	
9 '	7 '	NA	4	1	22" o.c.	23" o.c.	NA	8" o.c.	22" o.c.	16" o.c.	0	
9 '	8 '	NA	6	2	14" o.c.	16" o.c.	NA	6" o.c.	14" o.c.	13" o.c.	0	

NOTES:

1. Fastener Types A,B,C & D are not reflected in charts and are available prescriptively per table R404.1(1) in 2006 IRC.
2. See details for additional fastener options.
3. All fastener spacing must start within 12" maximum of each corner or half specified spacing (lesser of two).
4. Type F & G connectors are qty. per 16" oc. Joist spacing.
5. Fastener Type Key:
 "Type E"- Fasteners toe-nailed through rim joist into sill plate (Refer to Detail E)
 "Type F"- Fasteners direct nailed from sill plate into each floor joist (Applicable at Sidewalls only) (Refer to Detail F)
 "Type G"- Number of Simpson A23 angles fastened to sill plate and each 16" OC. (2x8 min. sill plate) (Refer to Detail G)
 "Type H"- Simpson LPT4 or TP35 plate fastened to rim joist and mud sill with (12) 8dx1.5" treated nails. (Refer to Detail H)
- Anchor Types:
 "Type 4"- 1/2" x10" Anchor Bolt with 2"x2"x1/8" Washer between plate and nut.
 "Type 5"- Simpson MAB15 (concrete) or MAB23 (concrete block) or MASA
6. Fasteners are in addition to (4) Type H tie plates spaced within 6' of corners & 83" oc. elsewhere along sidewalls.(See note 3)
7. Fasteners are in addition to Type H tie plates spaced at 25" oc. along endwall.
8. Three options (E,F,& G) for rim to sill fastening and two options (4 & 5) for sill plate to foundation anchorage have been provided in chart. Any combination of rim sill connectors and mud sill anchors maybe used.
9. All connection hardware, anchor bolts, straps, hold-downs, washers and fasteners shall be galvanized or stainless when in contact with PT sill plates or other PT lumber.
10. Maximum foundation wall height and maximum unbalanced backfill.

Home Floor to Sill Plate & Sill Plate to Foundation WITH TYPE H PLATE CONNECTORS (See note 6 & 7) SOIL CLASSES GM, GC, SM, SM-SC AND ML SOILS

Unit Width: 26.67' to 26.67' Max.

Unit Length: 72' Max.

Roof Pitch: 3/12 to 6/12

Max. Roof Overhang: 12 "

Max. Sidewall Height: 9 '

*Wind Speed (3s): 120

Seismic Zone C

APPROVED BY



Approval of this document does not authorize or approve any deviation or deviations from the requirements of applicable State Laws.

David Richter

Foundation Wall TM		MAXIMUM FASTENER SPACING OR FASTENERS PER JOIST SPACING ^{2,3 & 5}										# REQ'D S/W HDS SEE D18 /CORNER
		SIDEWALL FASTENING SPACING ¹					END WALL FASTENING					
		Rim to Sill TM		Sill to Fnd. Wall		Rim to Sill TM		Sill to Fnd. Wall				
Wall Height	Backfill Depth	Fastener Type			Anchor Spacing		Fastener Type		Anchor Spacing			
		E	F ⁴	G ⁴	4	5	E	G	4	5		
24 "	16 "	16.8" o.c.	1	1	72" o.c.	72" o.c.	53" o.c.	656" o.c.	42" o.c.	22" o.c.	1	
32 "	24 "	16.8" o.c.	1	1	72" o.c.	72" o.c.	21" o.c.	259" o.c.	42" o.c.	22" o.c.	1	
40 "	32 "	11.1" o.c.	1	1	72" o.c.	72" o.c.	11" o.c.	137" o.c.	40" o.c.	22" o.c.	1	
3.833 '	3.33 '	6.6" o.c.	2	1	61" o.c.	54" o.c.	7" o.c.	81" o.c.	37" o.c.	21" o.c.	1	
7 '	4 '	6.9" o.c.	2	1	65" o.c.	56" o.c.	7" o.c.	85" o.c.	37" o.c.	21" o.c.	1	
7 '	5 '	3.5" o.c.	3	1	31" o.c.	32" o.c.	4" o.c.	44" o.c.	28" o.c.	19" o.c.	1	
7 '	6 '	NA	5	1	18" o.c.	19" o.c.	NA	25" o.c.	18" o.c.	15" o.c.	0	
8 '	4 '	7.9" o.c.	2	1	72" o.c.	61" o.c.	8" o.c.	97" o.c.	38" o.c.	22" o.c.	1	
8 '	5 '	4.1" o.c.	3	1	36" o.c.	36" o.c.	4" o.c.	50" o.c.	30" o.c.	20" o.c.	1	
8 '	6 '	NA	4	1	20" o.c.	22" o.c.	NA	29" o.c.	20" o.c.	16" o.c.	0	
8 '	7 '	NA	7	2	13" o.c.	14" o.c.	NA	18" o.c.	13" o.c.	12" o.c.	0	
9 '	3 '	16.8" o.c.	1	1	72" o.c.	72" o.c.	21" o.c.	259" o.c.	42" o.c.	22" o.c.	1	
9 '	4 '	8.9" o.c.	2	1	72" o.c.	66" o.c.	9" o.c.	109" o.c.	39" o.c.	22" o.c.	1	
9 '	5 '	4.6" o.c.	2	1	41" o.c.	40" o.c.	5" o.c.	56" o.c.	32" o.c.	20" o.c.	1	
9 '	6 '	NA	4	1	23" o.c.	24" o.c.	NA	32" o.c.	23" o.c.	17" o.c.	0	
9 '	7 '	NA	6	2	14" o.c.	16" o.c.	NA	20" o.c.	14" o.c.	13" o.c.	0	
9 '	8 '	NA	9	0	10" o.c.	11" o.c.	NA	14" o.c.	10" o.c.	10" o.c.	0	

NOTES:

1. Fastener Types A,B,C & D are not reflected in charts and are available prescriptively per table R404.1(1) in 2006 IRC.
2. See details for additional fastener options.
3. All fastener spacing must start within 12" maximum of each corner or half specified spacing (lesser of two).
4. Type F & G connectors are qty. per 16" oc. Joist spacing.
5. Fastener Type Key:
 "Type E"- Fasteners toe-nailed through rim joist into sill plate (Refer to Detail E)
 "Type F"- Fasteners direct nailed from sill plate into each floor joist (Applicable at Sidewalls only) (Refer to Detail F)
 "Type G"- Number of Simpson A23 angles fastened to sill plate and each 16" OC. (2x8 min. sill plate) (Refer to Detail G)
 "Type H"- Simpson LPT4 or TP35 plate fastened to rim joist and mud sill with (12) 8dx1.5" treated nails. (Refer to Detail H)
 Anchor Types:
 "Type 4"- 1/2" x10" Anchor Bolt with 2"x2"x1/8" Washer between plate and nut.
 "Type 5"- Simpson MAB15 (concrete) or MAB23 (concrete block) or MASA
6. Fasteners are in addition to (4) Type H tie plates spaced within 6' of corners & 83" oc. elsewhere along sidewalls.(See note 3)
7. Fasteners are in addition to Type H tie plates spaced at 25" oc. along endwall.
8. Three options (E,F,& G) for rim to sill fastening and two options (4 & 5) for sill plate to foundation anchorage have been provided in chart. Any combination of rim sill connectors and mud sill anchors maybe used.
9. All connection hardware, anchor bolts, straps, hold-downs, washers and fasteners shall be galvanized or stainless when in contact with PT sill plates or other PT lumber.
10. Maximum foundation wall height and maximum unbalanced backfill.

9581-14.R.F.I.22.22.117()

Home Floor to Sill Plate & Sill Plate to Foundation WITH TYPE H PLATE CONNECTORS (See note 6 & 7) SOIL CLASSES SC, ML-CL AND INORGANIC CL SOILS

Unit Width: 26.67' to 26.67' Max.

Unit Length: 72' Max.

Roof Pitch: 3/12 to 6/12

Max. Roof Overhang: 12 "

Max. Sidewall Height: 9 '

*Wind Speed (3s): 120

Seismic Zone C

APPROVED BY



Approval of this document does not authorize or approve any deviation or deviations from the requirements of applicable State Laws.
David Richter

Foundation Wall ¹⁰		MAXIMUM FASTENER SPACING OR FASTENERS PER JOIST SPACING ^{2,3 & 5}										# REQ'D S/W HDS SEE D18 /CORNER
		SIDEWALL FASTENING SPACING ¹					END WALL FASTENING					
Wall Height	Backfill Depth	Rim to Sill ⁶			Sill to Fnd. Wall		Rim to Sill ⁷		Sill to Fnd. Wall			
		Fastener Type			Anchor Spacing		Fastener Type		Anchor Spacing			
		E	F ⁴	G ⁴	4	5	E	G	4	5		
24 "	16 "	16.8" o.c.	1	1	72" o.c.	72" o.c.	40" o.c.	492" o.c.	42" o.c.	22" o.c.	1	
32 "	24 "	15.8" o.c.	1	1	72" o.c.	72" o.c.	16" o.c.	194" o.c.	41" o.c.	22" o.c.	1	
40 "	32 "	8.4" o.c.	2	1	72" o.c.	63" o.c.	8" o.c.	102" o.c.	39" o.c.	22" o.c.	1	
3.833 '	3.33 '	4.9" o.c.	2	1	45" o.c.	43" o.c.	5" o.c.	61" o.c.	33" o.c.	20" o.c.	1	
7 '	4 '	5.2" o.c.	2	1	47" o.c.	45" o.c.	5" o.c.	64" o.c.	34" o.c.	21" o.c.	1	
7 '	5 '	NA	4	1	23" o.c.	25" o.c.	NA	33" o.c.	23" o.c.	17" o.c.	0	
7 '	6 '	NA	6	2	13" o.c.	14" o.c.	NA	19" o.c.	13" o.c.	12" o.c.	0	
8 '	4 '	5.9" o.c.	2	1	55" o.c.	50" o.c.	6" o.c.	73" o.c.	35" o.c.	21" o.c.	1	
8 '	5 '	3.0" o.c.	3	1	27" o.c.	28" o.c.	3" o.c.	37" o.c.	25" o.c.	18" o.c.	0	
8 '	6 '	NA	6	2	15" o.c.	16" o.c.	NA	22" o.c.	15" o.c.	14" o.c.	0	
8 '	7 '	NA	9	2	10" o.c.	10" o.c.	NA	14" o.c.	10" o.c.	10" o.c.	0	
9 '	3 '	15.8" o.c.	1	1	72" o.c.	72" o.c.	16" o.c.	194" o.c.	41" o.c.	22" o.c.	1	
9 '	4 '	6.7" o.c.	2	1	62" o.c.	54" o.c.	7" o.c.	82" o.c.	37" o.c.	21" o.c.	1	
9 '	5 '	3.4" o.c.	3	1	30" o.c.	31" o.c.	3" o.c.	42" o.c.	27" o.c.	19" o.c.	0	
9 '	6 '	NA	5	2	17" o.c.	18" o.c.	NA	24" o.c.	17" o.c.	15" o.c.	0	
9 '	7 '	NA	8	2	11" o.c.	12" o.c.	NA	15" o.c.	11" o.c.	11" o.c.	0	
9 '	8 '	NA	11	NA	7" o.c.	8" o.c.	NA	10" o.c.	7" o.c.	8" o.c.	0	

NOTES:

- Fastener Types A,B,C & D are not reflected in charts and are available prescriptively per table R404.1(1) in 2006 IRC.
- See details for additional fastener options.
- All fastener spacing must start within 12" maximum of each corner or half specified spacing (lesser of two).
- Type F & G connectors are qty. per 16" oc. Joist spacing.
- Fastener Type Key:
 "Type E"- Fasteners toe-nailed through rim joist into sill plate (Refer to Detail E)
 "Type F"- Fasteners direct nailed from sill plate into each floor joist (Applicable at Sidewalls only) (Refer to Detail F)
 "Type G"- Number of Simpson A23 angles fastened to sill plate and each 16" OC. (2x8 min. sill plate) (Refer to Detail G)
 "Type H"- Simpson LPT4 or TP35 plate fastened to rim joist and mud sill with (12) 8dx1.5" treated nails. (Refer to Detail H)
- Anchor Types:
 "Type 4"- 1/2" x10" Anchor Bolt with 2"x2"x1/8" Washer between plate and nut.
 "Type 5"- Simpson MAB15 (concrete) or MAB23 (concrete block) or MASA
- Fasteners are in addition to (4) Type H tie plates spaced within 6' of corners & 83" oc. elsewhere along sidewalls.(See note 3)
- Fasteners are in addition to Type H tie plates spaced at 25" oc. along endwall.
- Three options (E,F,& G) for rim to sill fastening and two options (4 & 5) for sill plate to foundation anchorage have been provided in chart. Any combination of rim sill connectors and mud sill anchors maybe used.
- All connection hardware, anchor bolts, straps, hold-downs, washers and fasteners shall be galvanized or stainless when in contact with PT sill plates or other PT lumber.
- Maximum foundation wall height and maximum unbalanced backfill.

958I-14.R.F.I.22.22.117()

Home Floor to Sill Plate & Sill Plate to Foundation WITHOUT TYPE H PLATE CONNECTORS (See note 6 & 7) SOIL CLASSES GW, GP, SW AND SP SOILS

Unit Width: 26.67' to 26.67' Max.

Unit Length: 72' Max.

Roof Pitch: 3/12 to 6/12

Max. Roof Overhang: 12 "

Max. Sidewall Height: 9 '

*Wind Speed (3s): 120

Seismic Zone C



MAXIMUM FASTENER SPACING OR FASTENERS PER JOIST SPACING ^{2,3 & 5}											# REQ'D S/W HDS SEE D18 /CORNER
SIDEWALL FASTENING SPACING ¹					END WALL FASTENING						
Foundation Wall ¹⁰		Rim to Sill ⁶			Sill to Fnd. Wall		Rim to Sill ⁷		Sill to Fnd. Wall		
Wall Height	Backfill Depth	Fastener Type			Anchor Spacing		Fastener Type		Anchor Spacing		
		E	F ⁴	G ⁴	4	5	E	G	4	5	
24 "	16 "	5.3" o.c.	2	1	72" o.c.	72" o.c.	6" o.c.	23" o.c.	42" o.c.	22" o.c.	1
32 "	24 "	5.3" o.c.	2	1	72" o.c.	72" o.c.	6" o.c.	22" o.c.	42" o.c.	22" o.c.	1
40 "	32 "	5.3" o.c.	2	1	72" o.c.	72" o.c.	6" o.c.	22" o.c.	41" o.c.	22" o.c.	1
3.833 '	3.33 '	5.2" o.c.	2	1	72" o.c.	70" o.c.	5" o.c.	20" o.c.	40" o.c.	22" o.c.	1
7 '	4 '	5.3" o.c.	2	1	72" o.c.	72" o.c.	6" o.c.	21" o.c.	40" o.c.	22" o.c.	1
7 '	5 '	4.1" o.c.	3	1	48" o.c.	45" o.c.	5" o.c.	17" o.c.	34" o.c.	21" o.c.	1
7 '	6 '	NA	4	1	27" o.c.	28" o.c.	3" o.c.	12" o.c.	25" o.c.	18" o.c.	1
8 '	4 '	5.3" o.c.	2	1	72" o.c.	72" o.c.	6" o.c.	21" o.c.	40" o.c.	22" o.c.	1
8 '	5 '	4.3" o.c.	3	1	56" o.c.	50" o.c.	5" o.c.	18" o.c.	36" o.c.	21" o.c.	1
8 '	6 '	3.1" o.c.	4	1	31" o.c.	32" o.c.	4" o.c.	13" o.c.	28" o.c.	19" o.c.	1
8 '	7 '	NA	5	1	19" o.c.	21" o.c.	NA	8" o.c.	19" o.c.	16" o.c.	1
9 '	3 '	5.3" o.c.	2	1	72" o.c.	72" o.c.	6" o.c.	22" o.c.	42" o.c.	22" o.c.	1
9 '	4 '	5.3" o.c.	2	1	72" o.c.	72" o.c.	6" o.c.	21" o.c.	41" o.c.	22" o.c.	1
9 '	5 '	4.6" o.c.	3	1	64" o.c.	55" o.c.	5" o.c.	19" o.c.	37" o.c.	21" o.c.	1
9 '	6 '	3.4" o.c.	3	1	35" o.c.	35" o.c.	4" o.c.	14" o.c.	30" o.c.	19" o.c.	1
9 '	7 '	NA	4	1	22" o.c.	23" o.c.	NA	9" o.c.	22" o.c.	16" o.c.	1
9 '	8 '	NA	6	2	14" o.c.	16" o.c.	NA	6" o.c.	14" o.c.	13" o.c.	1

NOTES:

1. RESERVED
2. See details for additional fastener options.
3. All fastener spacing must start within 12" maximum of each corner or half specified spacing (lesser of two).
4. Type F & G connectors are qty. per 16" oc. Joist spacing.
5. Fastener Type Key:
 " Type E"- Fasteners toe-nailed through rim joist into sill plate (Refer to Detail E)
 "Type F"- Fasteners direct nailed from sill plate into each floor joist (Applicable at Sidewalls only) (Refer to Detail F)
 "Type G"- Number of Simpson A23 angles fastened to sill plate and each 16" OC. (2x8 min. sill plate) (Refer to Detail G)
 "Type H"- Simpson LPT4 or TP35 plate fastened to rim joist and mud sill with (12) 8dx1.5" treated nails. (Refer to Detail H)
- Anchor Types:
 "Type 4"- 1/2" x10" Anchor Bolt with 2"x2"x1/8" Washer between plate and nut.
 "Type 5"- Simpson MAB15 (concrete) or MAB23 (concrete block) or MASA
6. Fasteners reflected in chart do NOT require "H type" connector plates to be installed along sidewall.
7. Fasteners reflected in chart do NOT require "H type" connector plates to be installed along endwall.
8. Three options (E,F,& G) for rim to sill fastening and two options (4 & 5) for sill plate to foundation anchorage have been provided in chart. Any combination of rim sill connectors and mud sill anchors may be used.
9. All connection hardware, anchor bolts, straps, hold-downs, washers and fasteners shall be galvanized or stainless when in contact with PT sill plates or other PT lumber.
10. Maximum foundation wall height and maximum unbalanced backfill.

9581-14.R.F.I.22.22.117(_)

Home Floor to Sill Plate & Sill Plate to Foundation WITHOUT TYPE H PLATE CONNECTORS (See note 6 & 7) SOIL CLASSES GM, GC, SM, SM-SC AND ML SOILS

Unit Width: 26.67' to 26.67' Max.

Unit Length: 72' Max.

Roof Pitch: 3/12 to 6/12

Max. Roof Overhang: 12 "

Max. Sidewall Height: 9 '

*Wind Speed (3s): 120

Seismic Zone C

APPROVED BY



Approval of this document does not authorize or approve any deviation or deviations from the requirements of applicable State Laws.

David Richter

Foundation Wall ¹⁰		MAXIMUM FASTENER SPACING OR FASTENERS PER JOIST SPACING ^{2,3 & 5}								# REQ'D S/W HDS SEE D18 /CORNER	
		SIDEWALL FASTENING SPACING ¹				END WALL FASTENING					
		Rim to Sill ⁶		Sill to Fnd. Wall		Rim to Sill ⁷		Sill to Fnd. Wall			
Wall Height	Backfill Depth	Fastener Type			Anchor Spacing		Fastener Type		Anchor Spacing		
		E ⁹	F ⁴	G ⁴	4	5	E	G	4	5	
24 "	16 "	5.3" o.c.	2	1	72" o.c.	72" o.c.	6" o.c.	22" o.c.	42" o.c.	22" o.c.	1
32 "	24 "	5.3" o.c.	2	1	72" o.c.	72" o.c.	6" o.c.	22" o.c.	42" o.c.	22" o.c.	1
40 "	32 "	5.3" o.c.	2	1	72" o.c.	72" o.c.	6" o.c.	21" o.c.	40" o.c.	22" o.c.	1
3.833 '	3.33 '	4.5" o.c.	3	1	61" o.c.	54" o.c.	5" o.c.	18" o.c.	37" o.c.	21" o.c.	1
7 '	4 '	4.6" o.c.	3	1	65" o.c.	56" o.c.	5" o.c.	19" o.c.	37" o.c.	21" o.c.	1
7 '	5 '	3.1" o.c.	4	1	31" o.c.	32" o.c.	4" o.c.	13" o.c.	28" o.c.	19" o.c.	1
7 '	6 '	NA	5	2	18" o.c.	19" o.c.	NA	8" o.c.	18" o.c.	15" o.c.	1
8 '	4 '	4.9" o.c.	3	1	72" o.c.	61" o.c.	5" o.c.	19" o.c.	38" o.c.	22" o.c.	1
8 '	5 '	3.4" o.c.	3	1	36" o.c.	36" o.c.	4" o.c.	14" o.c.	30" o.c.	20" o.c.	1
8 '	6 '	NA	5	1	20" o.c.	22" o.c.	NA	9" o.c.	20" o.c.	16" o.c.	1
8 '	7 '	NA	7	2	13" o.c.	14" o.c.	NA	5" o.c.	13" o.c.	12" o.c.	1
9 '	3 '	5.3" o.c.	2	1	72" o.c.	72" o.c.	6" o.c.	22" o.c.	42" o.c.	22" o.c.	1
9 '	4 '	5.1" o.c.	3	1	72" o.c.	66" o.c.	5" o.c.	20" o.c.	39" o.c.	22" o.c.	1
9 '	5 '	3.7" o.c.	3	1	41" o.c.	40" o.c.	4" o.c.	15" o.c.	32" o.c.	20" o.c.	1
9 '	6 '	NA	4	1	23" o.c.	24" o.c.	NA	10" o.c.	23" o.c.	17" o.c.	1
9 '	7 '	NA	6	2	14" o.c.	16" o.c.	NA	6" o.c.	14" o.c.	13" o.c.	1
9 '	8 '	NA	9	2	10" o.c.	11" o.c.	NA	4" o.c.	10" o.c.	10" o.c.	1

NOTES:

1. RESERVED
2. See details for additional fastener options.
3. All fastener spacing must start within 12" maximum of each corner or half specified spacing (lesser of two).
4. Type F & G connectors are qty. per 16" oc. Joist spacing.
5. Fastener Type Key:
 " Type E"- Fasteners toe-nailed through rim joist into sill plate (Refer to Detail E)
 "Type F"- Fasteners direct nailed from sill plate into each floor joist (Applicable at Sidewalls only) (Refer to Detail F)
 "Type G"- Number of Simpson A23 angles fastened to sill plate and each 16" OC. (2x8 min. sill plate) (Refer to Detail G)
 "Type H"- Simpson LPT4 or TP35 plate fastened to rim joist and mud sill with (12) 8dx1.5" treated nails. (Refer to Detail H)

Anchor Types:

- "Type 4"- 1/2" x10" Anchor Bolt with 2"x2"x1/8" Washer between plate and nut.
- "Type 5"- Simpson MAB15 (concrete) or MAB23 (concrete block) or MASA
6. Fasteners reflected in chart do NOT require "H type" connector plates to be installed along sidewall.
7. Fasteners reflected in chart do NOT require "H type" connector plates to be installed along endwall.
8. Three options (E,F,& G) for rim to sill fastening and two options (4 & 5) for sill plate to foundation anchorage have been provided in chart. Any combination of rim sill connectors and mud sill anchors maybe used.
9. All connection hardware, anchor bolts, straps, hold-downs, washers and fasteners shall be galvanized or stainless when in contact with PT sill plates or other PT lumber.
10. Maximum foundation wall height and maximum unbalanced backfill.

958I-14.R.F.I.22.22.117()

Home Floor to Sill Plate & Sill Plate to Foundation WITHOUT TYPE H PLATE CONNECTORS (See note 6 & 7) SOIL CLASSES SC, MH, ML-CL AND INORGANIC CL SOILS

Unit Width: 26.67' to 26.67' Max.

Unit Length: 72' Max.

Roof Pitch: 3/12 to 6/12

Max. Roof Overhang: 12 "

Max. Sidewall Height: 9 '

*Wind Speed (3s): 120

Seismic Zone C

APPROVED BY



Approval of this document does not authorize or approve any deviation or deviations from the requirements of applicable State Laws.

David Richter

Foundation Wall ¹⁰		MAXIMUM FASTENER SPACING OR FASTENERS PER JOIST SPACING ^{2,3 & 5}										# REQ'D S/W HDS SEE D18 /CORNER
		SIDEWALL FASTENING SPACING ¹					END WALL FASTENING					
		Rim to Sill ⁶			Sill to Fnd. Wall		Rim to Sill ⁷		Sill to Fnd. Wall			
Wall Height	Backfill Depth	Fastener Type			Anchor Spacing		Fastener Type		Anchor Spacing			
		E ⁹	F ⁴	G ⁴	4	5	E	G	4	5		
24 "	16 "	5.3" o.c.	2	1	72" o.c.	72" o.c.	6" o.c.	22" o.c.	42" o.c.	22" o.c.	1	
32 "	24 "	5.3" o.c.	2	1	72" o.c.	72" o.c.	6" o.c.	22" o.c.	41" o.c.	22" o.c.	1	
40 "	32 "	5.0" o.c.	3	1	72" o.c.	63" o.c.	5" o.c.	20" o.c.	39" o.c.	22" o.c.	1	
3.833 '	3.33 '	3.9" o.c.	3	1	45" o.c.	43" o.c.	4" o.c.	16" o.c.	33" o.c.	20" o.c.	1	
7 '	4 '	4.0" o.c.	3	1	47" o.c.	45" o.c.	5" o.c.	17" o.c.	34" o.c.	21" o.c.	1	
7 '	5 '	NA	4	1	23" o.c.	25" o.c.	NA	10" o.c.	23" o.c.	17" o.c.	1	
7 '	6 '	NA	7	2	13" o.c.	14" o.c.	NA	6" o.c.	13" o.c.	12" o.c.	1	
8 '	4 '	4.3" o.c.	3	1	55" o.c.	50" o.c.	5" o.c.	18" o.c.	35" o.c.	21" o.c.	1	
8 '	5 '	NA	4	1	27" o.c.	28" o.c.	3" o.c.	11" o.c.	25" o.c.	18" o.c.	1	
8 '	6 '	NA	6	2	15" o.c.	16" o.c.	NA	7" o.c.	15" o.c.	14" o.c.	1	
8 '	7 '	NA	9	2	10" o.c.	10" o.c.	NA	4" o.c.	10" o.c.	10" o.c.	1	
9 '	3 '	5.3" o.c.	2	1	72" o.c.	72" o.c.	6" o.c.	22" o.c.	41" o.c.	22" o.c.	1	
9 '	4 '	4.5" o.c.	3	1	62" o.c.	54" o.c.	5" o.c.	18" o.c.	37" o.c.	21" o.c.	1	
9 '	5 '	3.0" o.c.	4	1	30" o.c.	31" o.c.	4" o.c.	13" o.c.	27" o.c.	19" o.c.	1	
9 '	6 '	NA	5	2	17" o.c.	18" o.c.	NA	7" o.c.	17" o.c.	15" o.c.	1	
9 '	7 '	NA	8	2	11" o.c.	12" o.c.	NA	5" o.c.	11" o.c.	11" o.c.	1	
9 '	8 '	NA	11	NA	7" o.c.	8" o.c.	NA	3" o.c.	7" o.c.	8" o.c.	0	

NOTES:

- RESERVED
- See details for additional fastener options.
- All fastener spacing must start within 12" maximum of each corner or half specified spacing (lesser of two).
- Type F & G connectors are qty. per 16" oc. Joist spacing.
- Fastener Type Key:
 - "Type E"- Fasteners toe-nailed through rim joist into sill plate (Refer to Detail E)
 - "Type F"- Fasteners direct nailed from sill plate into each floor joist (Applicable at Sidewalls only) (Refer to Detail F)
 - "Type G"- Number of Simpson A23 angles fastened to sill plate and each 16" OC. (2x8 min. sill plate) (Refer to Detail G)
 - "Type H"- Simpson LPT4 or TP35 plate fastened to rim joist and mud sill with (12) 8dx1.5" treated nails. (Refer to Detail H)
- Anchor Types:
 - "Type 4"- 1/2" x10" Anchor Bolt with 2"x2"x1/8" Washer between plate and nut.
 - "Type 5"- Simpson MAB15 (concrete) or MAB23 (concrete block) or MASA
- Fasteners reflected in chart do NOT require "H type" connector plates to be installed along sidewall.
- Fasteners reflected in chart do NOT require "H type" connector plates to be installed along endwall.
- Three options (E,F,& G) for rim to sill fastening and two options (4 & 5) for sill plate to foundation anchorage have been provided in chart. Any combination of rim sill connectors and mud sill anchors maybe used.
- All connection hardware, anchor bolts, straps, hold-downs, washers and fasteners shall be galvanized or stainless when in contact with PT sill plates or other PT lumber.
- Maximum foundation wall height and maximum unbalanced backfill.

9581-14.R.F.I.22.22.117(_)

GENERAL NOTES:

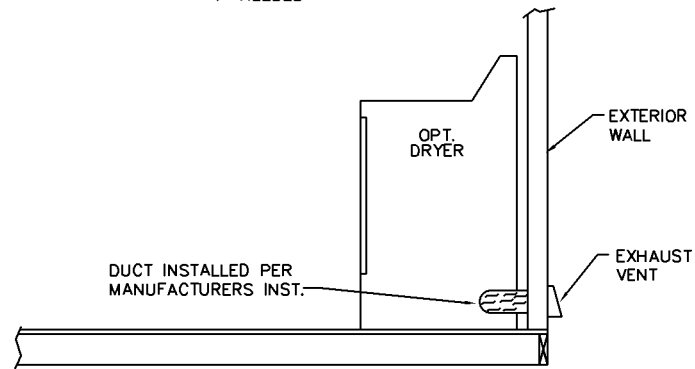
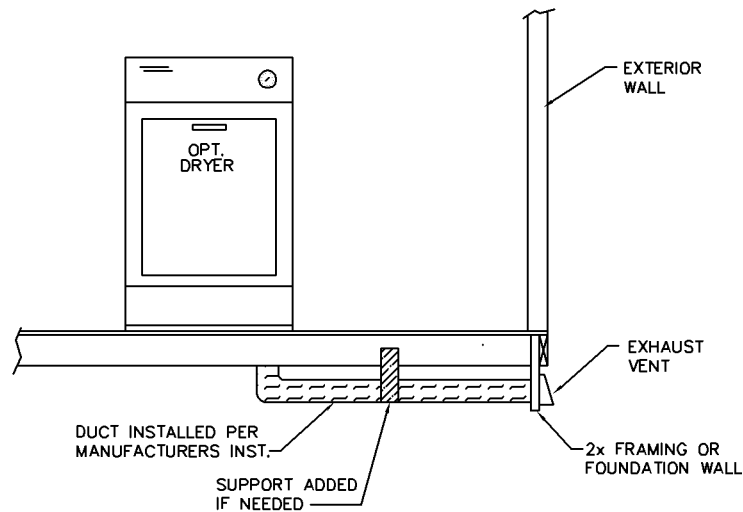

INSTALLTION INSTRUCTIONS:

EXHAUST DUCTS FOR DOMESTIC CLOTHES DRYERS SHALL BE CONSTRUCTED OF METAL OR NONCOMBUSTIBLE MATERIAL OF EQUAL STRENGTH AND CORROSION RESISTANCE AND SHALL HAVE A SMOOTH INTERIOR FINISH. NO PART OF THE DRYER DUCT TO BE IN CONTACT WITH THE GROUND. THE DUCT TO RUN TO THE OUTSIDE OF THE UNIT AND SHALL NOT TERMINATE UNDERNEATH THE UNIT. A APPROVED DAMPER TO BE INSTALLED ON THE END OF THE DUCT.

APPROVAL SEAL:

APPROVED BY
NIA 1/10/2019
INC.
Approval of this document does not authorize or approve any deviation or deviations from the requirements of applicable State Laws.
David Richter

GMH Engineering

TITLE:
DRYER VENT INSTALLATION

Drawn by: O'Neal

Date: 4/11/07 Draw #:

ELECTRICAL LEGEND (NOT TO SCALE)			
	LIGHT		PANEL BOX
	CAN LIGHT		THERMOSTAT
	PULL CHAIN LIGHT		SWITCH
	BATH FAN		3-WAY SWITCH
	FLUORESCENT LIGHT		PHONE JACK
	CABLE JACK		CEILING MOUNT C.O. & SMOKE DETECTOR
	15 AMP RECEPT FLOOR LEVEL		CEILING MOUNT C.O. DETECTOR
	15 AMP RECEPT CABINET LEVEL		WALL MOUNT SMOKE DETECTOR
	15 AMP RECEPT SIDWAYS		CEILING MOUNT SMOKE DETECTOR
	20 AMP RECEPT FLOOR LEVEL		SWITCH LEG
	20 AMP RECEPT CABINET LEVEL		JUNCTION BOX
	20 AMP RECEPT SIDWAYS		CEILING FAN
	240 VOLT RECEPT		
	15 AMP WATERPROOF RECEPT		POT & PAN RACK
	20 AMP WATERPROOF RECEPT		HEAT TAPE RECEPT
	FURNACE		WATER HEATER
A DASHED SYMBOL REPRESENTS AN OPTION			
GFI-INDICATES A GROUND FAULT PROTECTED RECEPT			

APPROVED BY

 1/10/2019
 Approval of this document does not authorize or approve any deviation or deviations from the requirements of applicable State Laws.
 David Richter

PLUMBING FIXTURE DESCRIPTION CHART

APPLIANCE	MANUFACTURER	MODEL #	ANSI/ASME STANDARD
TOILET	BRISTOL BAY	VCEFB-03B	
SINKS	LYONS EL MUSTICE & SON PREMIUM FLOW CORESTONE & TEKA REVERE	KS01P4-TB #610 UTILITY SINGLE BOWL DOUBLE BOWL BAR SINK	
LAVATORIES	BRISTOL BAY	VCL-10	
TUB SHOWER	BAYMONT BATHWARE	5118 5100 5109	UL
SHOWER	BAYMONT BATHWARE	3309 3308 3304	UL
TUB	BAYMONT BATHWARE	2205 2272	UL

APPROVED BY

 1/10/2019
David Richter

Approval of this document does not authorize or approve any deviation or deviations from the requirements of applicable State Laws.

Trenco

818 Soundside Rd
Edenton, NC 27932

Re: WPL-913-0815-015_(14W)
CMH MANUFACTURING - SCHULT (Rich-NC)

The truss drawing(s) referenced below have been prepared by Truss Engineering Co. under my direct supervision based on the parameters provided by Wood Perfect, Ltd.

Pages or sheets covered by this seal: I33865959 thru I33865960

My license renewal date for the state of North Carolina is December 31, 2018.

North Carolina COA: C-0844



APPROVED BY
NIA INC. 1/10/2019
Approval of this document does not authorize or approve any deviation or deviations from the requirements of applicable State Laws.
David Richter

July 3, 2018

Galinski, John

IMPORTANT NOTE: Truss Engineer's responsibility is solely for design of individual trusses based upon design parameters shown on referenced truss drawings. Parameters have not been verified as appropriate for any use. Any location identification specified is for file reference only and has not been used in preparing design. Suitability of truss designs for any particular building is the responsibility of the building designer, not the Truss Engineer, per ANSI/TPI-1, Chapter 2.

Job	Truss	Truss Type	Qty	Ply	CMH MANUFACTURING - SCHULT (Rich-NC)	133865959
WPL-913-0815-015_(14W)	9481-15	HINGED TRUSS	1	1	M9481 : 6/12 28 WIDE MOD/HUD - 15 Job Reference (optional)	

Wood Perfect, LLC, Guin, AL 33563

7.640 s Apr 22 2016 MiTek Industries, Inc. Tue Jul 03 08:11:10 2018 Page 1
ID:OSyOryKpgL?u9DUM6cUhlKzWMnz-lxetKYT_vlZAgMZygVuFqZorlpuJvxhW05UMVz?qmF

APPROVED BY
NIA INC.
1/10/2019
Approval of this document does not authorize or approve any deviation or deviations from the requirements of applicable State Laws.
David Richter

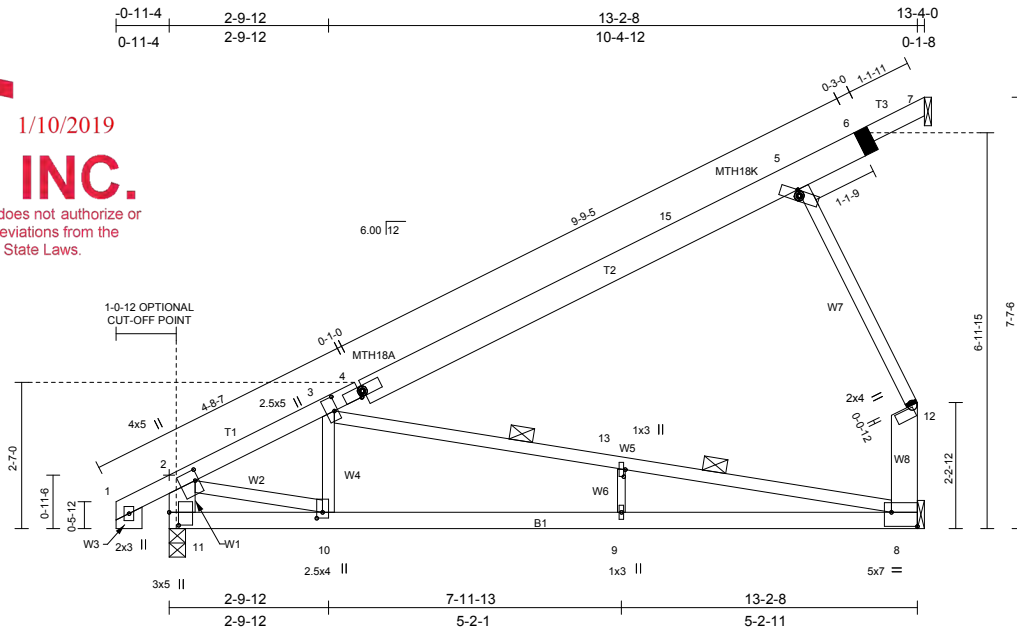

Plate Offsets (X,Y)--	[2:0-2-4,0-0-12], [3:0-3-0,0-0-12], [4:0-0-11,0-1-2], [5:0-0-11,0-1-2], [8:Edge,0-3-0], [10:0-1-4,0-1-4], [11:0-1-4,0-2-7], [11:0-2-12,0-2-0], [13:0-1-8,0-0-5]
-----------------------	---

SPACING--: 2-0-0 LOADING (psf) TCLL 23.1 (Ground Snow=30.0) TCDL 11.0 BCLL 0.0 * BCDL 10.0	SPACING--: 1-4-0 LOADING (psf) TCLL 34.7 (Ground Snow=45.0) TCDL 16.5 BCLL 0.0 * BCDL 15.0	SPACING--: 2-0-0 Plate Grip DOL 1.15 Lumber DOL 1.15 Rep Stress Incr YES Code IBC2015/TPI2014	CSI. TC 0.54 BC 1.00 WB 0.94 (Matrix)	DEFL. in (loc) l/defl L/d Vert(LL) -0.33 8-9 >460 240 Vert(CT) -0.60 8-9 >253 180 Horz(CT) -0.01 8 n/a n/a	PLATES GRIP MT20 197/144 MT18HS 197/144 Weight: 60 lb FT = 0%
--	--	--	--	--	--

LUMBER- TOP CHORD 2x4 SPF No.2 *Except* 4-6: 2x6 SPF No.2 BOT CHORD 2x4 SPF No.2 WEBS 2x3 SPF Stud *Except* 8-12,2-11,1-14: 2x6 SPF Stud, 9-13: 1-8/16x1-10/16 SPF Stud/Std	RIPPED LUMBER MUST BE RE-GRADED FOR SIZES AS SHOWN	BRACING- TOP CHORD Structural wood sheathing directly applied or 5-10-10 oc purlins, except end verticals. BOT CHORD Rigid ceiling directly applied or 1-4-12 oc bracing. WEBS 2 Rows at 1/3 pts 3-8 JOINTS 1 Brace at Jt(s): 12
---	---	---

REACTIONS. (lb/size) 11=677/0-3-8, 8=547/Mechanical, 7=0/Mechanical
Max Horz 11=401(LC 12), 7=-78(LC 19)
Max Uplift 11=-294(LC 12), 8=-455(LC 12)
Max Grav 11=707(LC 19), 8=637(LC 19)

FORCES. (lb) - Maximum Compression/Maximum Tension
TOP CHORD 1-2=0/60, 2-3=-846/291, 3-4=-391/0, 4-15=-402/29, 5-15=-238/41, 5-6=-164/61, 6-7=-91/72, 8-12=-407/449,
2-11=-700/353
BOT CHORD 10-11=-469/141, 9-10=-695/672, 8-9=-695/672
WEBS 3-10=-105/249, 3-13=-557/502, 8-13=-555/494, 5-12=-448/495, 2-10=-236/816, 9-13=-16/43

REQUIRED FIELD JOINT CONNECTIONS - Maximum Compression (lb)/ Maximum Tension (lb)/ Maximum Shear (lb)/ Maximum Moment (lb-in)
6=115/68/48/0, 12=448/496/0/0

- NOTES-**
- 1) Wind: ASCE 7-10; Vult=152mph (3-second gust) Vasd=120mph @24in o.c.; TCDL=4.4psf; BCDL=4.0psf; (Alt. 180mph @16in o.c.; TCDL=6.6psf; BCDL=6.0psf); h=22ft; Cat. II; Exp C; enclosed; MWFRS (envelope) gable end zone and C-C Exterior(2) zone; end vertical left exposed; C-C for members and forces & MWFRS for reactions shown; Lumber DOL=1.60 plate grip DOL=1.60
 - 2) TCLL: ASCE 7-10; Pg=30.0 psf (ground snow); Ps=23.1 psf (roof snow); Category II; Exp C; Partially Exp.; Ct=1.1
 - 3) Roof design snow load has been reduced to account for slope.
 - 4) Unbalanced snow loads have been considered for this design.
 - 5) This truss has been designed for greater of min roof live load of 18.0 psf or 2.00 times flat roof load of 23.1 psf on overhangs non-concurrent with other live loads.
 - 6) As requested, plates have not been designed to provide for placement tolerances or rough handling and erection conditions. It is the responsibility of the fabricator to increase plate sizes to account for these factors.
 - 7) All plates are MT20 plates unless otherwise indicated.
 - 8) See HINGE PLATE DETAILS for plate placement.
 - 9) Provisions must be made to prevent lateral movement of hinged member(s) during transportation.
 - 10) All additional member connections shall be provided by others for forces as indicated.
 - 11) This truss has been designed for a 10.0 psf bottom chord live load nonconcurrent with any other live loads.
 - 12) * This truss has been designed for a live load of 20.0psf on the bottom chord in all areas where a rectangle 3-6-0 tall by 2-0-0 wide will fit between the bottom chord and any other members.
 - 13) Provide mechanical connection (by others) of truss to bearing plate capable of withstanding 294 lb uplift at joint 11 and 455 lb uplift at joint 8.



July 3, 2018

Continued on page 2

WARNING - Verify design parameters and READ NOTES ON THIS AND INCLUDED MITEK REFERENCE PAGE MII-7473 rev. 10/03/2015 BEFORE USE.
Design valid for use only with MiTek® connectors. This design is based only upon parameters shown, and is for an individual building component, not a truss system. Before use, the building designer must verify the applicability of design parameters and properly incorporate this design into the overall building design. Bracing indicated is to prevent buckling of individual truss web and/or chord members only. Additional temporary and permanent bracing is always required for stability and to prevent collapse with possible personal injury and property damage. For general guidance regarding the fabrication, storage, delivery, erection and bracing of trusses and truss systems, see **ANSI/TP1 Quality Criteria, DSB-89 and BCSI Building Component Safety Information** available from Truss Plate Institute, 218 N. Lee Street, Suite 312, Alexandria, VA 22314.

TRENCO
818 Soundside Road
Edenton, NC 27932

Job	Truss	Truss Type	Qty	Ply	CMH MANUFACTURING - SCHULT (Rich-NC)	I33865959
WPL-913-0815-015_(14W)	9481-15	HINGED TRUSS	1	1	M9481 : 6/12 28 WIDE MOD/HUD - 15 Job Reference (optional)	

Wood Perfect, LLC, Guin, AL 33563

7.640 s Apr 22 2016 MiTek Industries, Inc. Tue Jul 03 08:11:10 2018 Page 2
ID:OSyOryKpgL?u9DUM6cUhlKzWMnz-lxetkYT_vlZAZgMZygVuFqZorlpuJvxhW05UMVz?qmF

NOTES-

- 14) This truss is designed in accordance with the 2015 International Building Code section 2306.1 and referenced standard ANSI/TPI 1.
- 15) "Semi-rigid pitchbreaks including heels" Member end fixity model was used in the analysis and design of this truss.

APPROVED BY



1/10/2019

David Richter

Approval of this document does not authorize or approve any deviation or deviations from the requirements of applicable State Laws.

WARNING - Verify design parameters and READ NOTES ON THIS AND INCLUDED MITEK REFERENCE PAGE MII-7473 rev. 10/03/2015 BEFORE USE.

Design valid for use only with MiTek® connectors. This design is based only upon parameters shown, and is for an individual building component, not a truss system. Before use, the building designer must verify the applicability of design parameters and properly incorporate this design into the overall building design. Bracing indicated is to prevent buckling of individual truss web and/or chord members only. Additional temporary and permanent bracing is always required for stability and to prevent collapse with possible personal injury and property damage. For general guidance regarding the fabrication, storage, delivery, erection and bracing of trusses and truss systems, see **ANSI/TPI1 Quality Criteria, DSB-89 and BCSI Building Component Safety Information** available from Truss Plate Institute, 218 N. Lee Street, Suite 312, Alexandria, VA 22314.



818 Soundside Road
Edenton, NC 27932

Trenco

818 Soundside Rd
Edenton, NC 27932

Re: WPL-913-0815-015_(14W)
CMH MANUFACTURING - SCHULT (Rich-NC)

The truss drawing(s) referenced below have been prepared by Truss Engineering Co. under my direct supervision based on the parameters provided by Wood Perfect, Ltd.

Pages or sheets covered by this seal: I33882273 thru I33882274

My license renewal date for the state of North Carolina is December 31, 2018.

North Carolina COA: C-0844



July 5, 2018

Galinski, John

IMPORTANT NOTE: Truss Engineer's responsibility is solely for design of individual trusses based upon design parameters shown on referenced truss drawings. Parameters have not been verified as appropriate for any use. Any location identification specified is for file reference only and has not been used in preparing design. Suitability of truss designs for any particular building is the responsibility of the building designer, not the Truss Engineer, per ANSI/TPI-1, Chapter 2.

Job	Truss	Truss Type	Qty	Ply	CMH MANUFACTURING - SCHULT (Rich-NC)	I33882273
WPL-913-0815-015_(14W)	9481-15	HINGED TRUSS	1	1	T9481 : 6/12 28 W. MONO TRAY - 15 Job Reference (optional)	

Wood Perfect, LLC, Guin, AL 33563

7.640 s Apr 22 2016 MiTek Industries, Inc. Thu Jul 05 07:54:39 2018 Page 2
ID:STKLz_7KTO426IVH1OQOzbyJwH0-19Vmg0ikfdhT91HtE8Nk3tsIA?_NykYTxCFM2hz?Apk

NOTES-

- 13) Provide mechanical connection (by others) of truss to bearing plate capable of withstanding 291 lb uplift at joint 2 and 458 lb uplift at joint 8.
- 14) This truss is designed in accordance with the 2015 International Building Code section 2306.1 and referenced standard ANSI/TPI 1.
- 15) "Semi-rigid pitchbreaks including heels" Member end fixity model was used in the analysis and design of this truss.

APPROVED BY



1/10/2019

David Richter

Approval of this document does not authorize or approve any deviation or deviations from the requirements of applicable State Laws.

WARNING - Verify design parameters and READ NOTES ON THIS AND INCLUDED MITEK REFERENCE PAGE MII-7473 rev. 10/03/2015 BEFORE USE.

Design valid for use only with MiTek® connectors. This design is based only upon parameters shown, and is for an individual building component, not a truss system. Before use, the building designer must verify the applicability of design parameters and properly incorporate this design into the overall building design. Bracing indicated is to prevent buckling of individual truss web and/or chord members only. Additional temporary and permanent bracing is always required for stability and to prevent collapse with possible personal injury and property damage. For general guidance regarding the fabrication, storage, delivery, erection and bracing of trusses and truss systems, see **ANSI/TPI1 Quality Criteria, DSB-89 and BCSI Building Component Safety Information** available from Truss Plate Institute, 218 N. Lee Street, Suite 312, Alexandria, VA 22314.



818 Soundside Road
Edenton, NC 27932

Symbols

PLATE LOCATION AND ORIENTATION

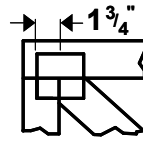

Center plate on joint unless x, y offsets are indicated. Dimensions are in ft-in-sixteenths. Apply plates to both sides of truss and fully embed teeth.

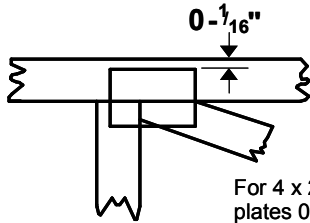

For 4 x 2 orientation, locate plates 0- 1/16" from outside edge of truss.



This symbol indicates the required direction of slots in connector plates.

* Plate location details available in MiTek 20/20 software or upon request.

PLATE SIZE

4 x 4

The first dimension is the plate width measured perpendicular to slots. Second dimension is the length parallel to slots.

LATERAL BRACING LOCATION



Indicated by symbol shown and/or by text in the bracing section of the output. Use T or I bracing if indicated.

BEARING

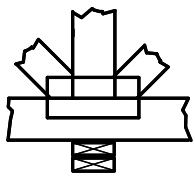

Indicates location where bearings (supports) occur. Icons vary but reaction section indicates joint number where bearings occur. Min size shown is for crushing only.

Industry Standards:

- ANSI/TPI1: National Design Specification for Metal Plate Connected Wood Truss Construction.
- DSB-89: Design Standard for Bracing.
- BCSI: Building Component Safety Information, Guide to Good Practice for Handling, Installing & Bracing of Metal Plate Connected Wood Trusses.

Numbering System

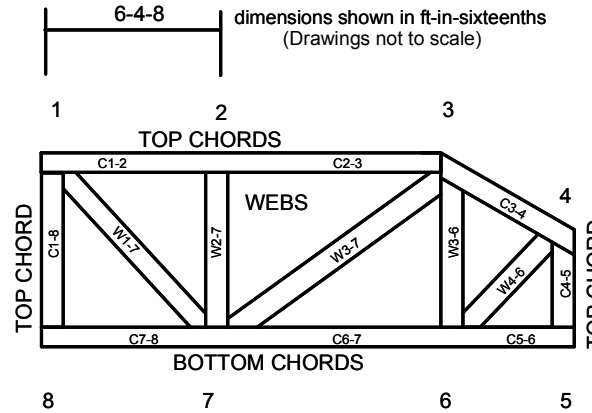

JOINTS ARE GENERALLY NUMBERED/LETTERED CLOCKWISE AROUND THE TRUSS STARTING AT THE JOINT FARTHEST TO THE LEFT.

CHORDS AND WEBS ARE IDENTIFIED BY END JOINT NUMBERS/LETTERS.

PRODUCT CODE APPROVALS
ICC-ES Reports:

ESR-1311, ESR-1352, ESR1988
ER-3907, ESR-2362, ESR-1397, ESR-3282

APPROVED BY
NIA INC.
1/10/2015
Approval of this document does not authorize or approve any deviation or deviations from the requirements of applicable State Laws.
David Richter

Trusses are designed for wind loads in the plane of the truss unless otherwise shown.

Lumber design values are in accordance with ANSI/TPI 1 section 6.3 These truss designs rely on lumber values established by others.

© 2012 MiTek® All Rights Reserved



MiTek Engineering Reference Sheet: MII-7473 rev. 10/03/2015

General Safety Notes

Failure to Follow Could Cause Property Damage or Personal Injury

1. Additional stability bracing for truss system, e.g. diagonal or X-bracing, is always required. See BCSI.
2. Truss bracing must be designed by an engineer. For wide truss spacing, individual lateral braces themselves may require bracing, or alternative Tor I bracing should be considered.
3. Never exceed the design loading shown and never stack materials on inadequately braced trusses.
4. Provide copies of this truss design to the building designer, erection supervisor, property owner and all other interested parties.
5. Cut members to bear tightly against each other.
6. Place plates on each face of truss at each joint and embed fully. Knots and wane at joint locations are regulated by ANSI/TPI 1.
7. Design assumes trusses will be suitably protected from the environment in accord with ANSI/TPI 1.
8. Unless otherwise noted, moisture content of lumber shall not exceed 19% at time of fabrication.
9. Unless expressly noted, this design is not applicable for use with fire retardant, preservative treated, or green lumber.
10. Lumber is a non-structural consideration and is the responsibility of truss fabricator. General practice is to lumber for dead load deflection.
11. Plate type, size, orientation and location dimensions indicated are minimum plating requirements.
12. Lumber used shall be of the species and size, and in all respects, equal to or better than that specified.
13. Top chords must be sheathed or purlins provided at spacing indicated on design.
14. Bottom chords require lateral bracing at 10 ft. spacing, or less, if no ceiling is installed, unless otherwise noted.
15. Connections not shown are the responsibility of others.
16. Do not cut or alter truss member or plate without prior approval of an engineer.
17. Install and load vertically unless indicated otherwise.
18. Use of green or treated lumber may pose unacceptable environmental, health or performance risks. Consult with project engineer before use.
19. Review all portions of this design (front, back, words and pictures) before use. Reviewing pictures alone is not sufficient.
20. Design assumes manufacture in accordance with ANSI/TPI 1 Quality Criteria.

NORTH CAROLINA		
MODULAR PLANS REVIEW CHECKLIST		
	PAGE 1 of 3	revised May 2011
Manufacturer	CMH MANUFACTURING INC.	
Model number/name	5531-28W-3BR	
3rd Party	NTA INC.	
Review Date	1/10/19	
Reviewer	DAVID RICHTER	
	Plan Sheet Page # and NOTES	
<u>QC MANUAL</u> (current and complete)		
<u>APPENDIX B</u> (required and attached)	single family dwelling - not required	
PLAN SHEETS		
Each plan sheet third-party stamped with approver's name		
Each plan sheet is numbered and/or indexed	IX-1	
GENERAL (cover sheet)		
Code References	1-0	
Statement regarding connection to public utilities	1-0	
Statement regarding bathrooms if not included	1-0	
Construction type	1-0	
Occupancy classification	1-0	
Fire resistance ratings (if required)	1-0	
Floor live load	1-0	
Roof live load	1-0	
Design wind velocity	1-0	
Seismic information (commercial projects)	1-0	
Thermal zones	1-0, HDD on REScheck (attached)	
Notice to inspections department regarding items to be site installed	1-0	
FLOOR PLANS		
Interior and exterior wall layouts	1-1, 1-2	
Door and window schedule	1-0.2	
Light and Ventilation requirements	TS-1	
Attic access (size and location)	1-1	
Non-prescriptive headers	Charts on 1-0, calc ref on 1-0	
Safety glazing requirements	1-1, 1-2	
Fire rating of Exterior walls (if applicable)		
EXTERIOR ELEVATIONS		
Exterior materials	20-1, 20-2, 1-0.2	
Attic ventilation requirements	20-1, 20-2	
PLUMBING		
Plan	locations on floor plan 1-1	
All fixtures furnished by mfg. shown on plans	1-1, 1-2	
Materials (water supply & distribution, DWV, storm drainage)	DWV: 8-1; Supply: 9-1	
Supply and waste risers, including DWV system (generic) beneath the building	DWV: 8-1; Supply: 9-1	
Water heater (type and capacity)	ref to electrical appliances on 1-0	

**NORTH CAROLINA
MODULAR PLANS REVIEW CHECKLIST**

PAGE 2 of 3

revised May 2011

Plan Sheet Page # and NOTES

MECHANICAL

Design calculations	attached
Installed unit capacity	attached
Supply and returns (locations and sizes)	4-3A
Duct sizes	4-3A
Specifications (units, ducts)	1-1, 4-3A
All appliances furnished by mfg. shown on plans	1-1, exhaust fans 11-1

ELECTRICAL

Plan	11-1
Location of all electrical boxes	11-1
Electrical panel location	11-1
Note regarding main disconnect (if applicable)	
Exterior lighting and receptacles	11-1
Ground level receptacles (if applicable)	11-1
Smoke detector location(s)	11-1
Electrical load calculations	TS-5
Electrical panel layout (breaker and wire sizes, circuit schedule)	11-1
Panel and service entrance sizes	Panel: 1-0a, SE ref in set-up on 1-0
All fixtures furnished by mfg. shown on plans	11-1

ACCESSIBILITY

(for other than 1 & 2 family dwellings)

Entrances and means of egress	
Doors, doorways, and door hardware	
Stairs and handrails	
Toilet rooms, plumbing fixtures, grab bars, etc	
Bathrooms and shower rooms	
Occupancy specific requirements	
Multi-family dwellings: Type A and B units	

FLOOR X-SECTION

Joist and beam sizes and spacing	1-0.2
Materials species and grade	1-0.2
Sheathing, decking, and concrete as applicable	1-0.2
Fastening instructions	1-0.2
Insulation	1-0.2
Details as required for clarification	1-0.2, other details ref manual on 1-0.2

WALL X-SECTION

Stud and column sizes and spacing	studs: 1-0.2; column charts: 1-0.2
Materials species and grade	1-0.2
Sheathing and bracing	1-0.2
Headers and lintels	header charts: 1-0.2
Finishes	1-0.2
Fastening instructions	1-0.2
Insulation	1-0.2
Details as required for clarificaion	Ref manual on 1-0.2

**NORTH CAROLINA
MODULAR PLANS REVIEW CHECKLIST**

PAGE 3 of 3

revised May 2011

Plan Sheet Page # and NOTES

CEILING/ROOF X-SECTION

Truss, rafter, and beam spacing	1-0.2
Lumber species and grade	1-0.2
Sheathing and decking	1-0.2
Finishes	1-0.2
Fastening instructions	1-0.2
Insulation	1-0.2
Details including NC sealed truss designs or manual reference	man ref to trusses 1-0.2, other details man ref 1-0.2

FOUNDATION PLAN

Footings, pier, and curtain wall locations and specifications	21-30 PSF (OFF FRAME) / 21-PS (ON FRAME)
X-sections with dimensions	21-30 PSF (OFF FRAME) / 21-PS (ON FRAME)
Anchorage - sill plate to piers and curtain wall	21-30 PSF (OFF FRAME) / 21-PS (ON FRAME)
Anchorage - building to sill plate	21-30 PSF (OFF FRAME) / 21-PS (ON FRAME)
Anchorage - tie downs (lateral and longitudinal)	21-30 PSF (OFF FRAME) / 21-PS (ON FRAME)
Soil bearing capacity	21-30 PSF (OFF FRAME) / 21-PS (ON FRAME)
Minimum concrete compressive strength	21-30 PSF (OFF FRAME) / 21-PS (ON FRAME)
Mortar type	21-30 PSF (OFF FRAME) / 21-PS (ON FRAME)
Ventilation requirements (with and without vapor barrier)	21-30 PSF (OFF FRAME) / 21-PS (ON FRAME)
Crawl space access requirements	21-30 PSF (OFF FRAME) / 21-PS (ON FRAME)

ENERGY COMPLIANCE

Demonstrate compliance	PRESCRIPTIVE
------------------------	--------------

SET-UP INSTRUCTIONS

Floor and ceiling connections	ref to set-up manual on 1-0.2
Marriage wall connections	ref to set-up manual on 1-0.2
Roof set-up connections	ref to set-up manual on 1-0.2
Plumbing connections	ref to set-up manual on 1-0.2
Mechanical connections	ref to set-up manual on 1-0.2
Electrical connections	ref to set-up manual on 1-0.2
Fire stopping	1-0.2
Air infiltration elimination	ref to set-up manual on 1-0.2
Notice to inspections department attachment if set-up instructions are by attachment	1-0.2

ITEMS NOT INSPECTED IN PLANT

List of items not inspected by 3rd. Party	1-0.2
Notice to inspections department	1-0.2