

NC



PILOT MOUNTAIN, NORTH CAROLINA

**STRUCTURAL DESIGN
ENCLOSED BUILDING**

**MAXIMUM 30'-0" WIDE X 16'-0" EAVE HEIGHT- BOX EAVE
FRAME**

25 June 2019

Revision 1

M&A Project No. 18315S/19179S

Prepared for:

NC Carports and Garages, LLC
309 S. Depot Street
Pilot Mountain, NC 27041

Prepared by:

Moore and Associates Engineering
and Consulting, Inc.

1009 East Avenue
North Augusta, SC 29841

401 S. Main St., Suite 200
Mt. Airy, NC 27030



MOORE AND ASSOCIATES
ENGINEERING AND CONSULTING

MOORE AND ASSOCIATES
ENGINEERING AND CONSULTING, INC.

DRAWN BY: JG
CHECKED BY: PH
PROJECT MGR: WSM
CLIENT: NC CARPORTS

NC CARPORTS AND GARAGES, LLC
309 S. DEPOT STREET
PILOT MOUNTAIN, NC 27041
30'-0" x 16'-0" ENCLOSED STRUCTURE

THIS DOCUMENT IS THE PROPERTY OF MOORE AND ASSOCIATES ENGINEERING AND CONSULTING. THE UNAUTHORIZED REPRODUCTION, COPYING, OR OTHERWISE USE OF THIS DOCUMENT IS STRICTLY PROHIBITED AND ANY INFRINGEMENT THEREUPON MAY BE SUBJECT TO LEGAL ACTION.

DATE: 6-25-19
SCALE: NTS
SHT. 1
DWG. NO: SK-3
JOB NO: 18315S/19179S
REV: 1

DRAWING INDEX

SHEET 1	PE SEAL COVER SHEET
SHEET 2	DRAWING INDEX
SHEET 3A	INSTALLATION NOTES AND SPECIFICATIONS
SHEET 3B	TYPICAL SIDE AND END ELEVATIONS
SHEET 3C	TYPICAL SIDE AND END ELEVATIONS
SHEET 4	TYPICAL RAFTER/COLUMN FRAME AND SIDE FRAMING SECTION (BOX EAVE STRUCTURE)
SHEET 4A	TYPICAL RAFTER/COLUMN FRAME AND SIDE FRAMING SECTION (BOX EAVE STRUCTURE)
SHEET 4B	TYPICAL RAFTER/COLUMN FRAME AND SIDE FRAMING SECTION (BOX EAVE STRUCTURE)
SHEET 4C	TYPICAL RAFTER/COLUMN FRAME AND SIDE FRAMING SECTION (BOX EAVE STRUCTURE)
SHEET 5	COLUMN CONNECTION DETAILS (BOX EAVE STRUCTURE)
SHEET 6	COLUMN CONNECTION DETAILS (BOX EAVE STRUCTURE)
SHEET 7	BASE RAIL ANCHORAGE OPTIONS
SHEET 7A	BASE RAIL ANCHORAGE OPTIONS
SHEET 8	TYPICAL END WALL AND SIDE WALL FRAMING SECTIONS
SHEET 8A	TYPICAL END WALL AND SIDE WALL FRAMING SECTIONS
SHEET 9	CONNECTION DETAILS
SHEET 10	CONNECTION DETAILS
SHEET 10A	CONNECTION DETAILS
SHEET 11	LEAN-TO OPTIONS
SHEET 11A	LEAN-TO OPTIONS
SHEET 12	VERTICAL ROOF/SIDING OPTION END AND SIDE ELEVATION AND SECTION
SHEET 12A	VERTICAL ROOF/SIDING OPTION END AND SIDE ELEVATION AND SECTION

MOORE AND ASSOCIATES ENGINEERING AND CONSULTING, INC.	DRAWN BY: JG		NC CARPORTS AND GARAGES, LLC 309 S. DEPOT STREET PILOT MOUNTAIN, NC 27041 30'-0" x 16'-0" ENCLOSED STRUCTURE		
	CHECKED BY: PH				
THIS DOCUMENT IS THE PROPERTY OF MOORE AND ASSOCIATES ENGINEERING AND CONSULTING. THE UNAUTHORIZED REPRODUCTION, COPYING, OR OTHERWISE USE OF THIS DOCUMENT IS STRICTLY PROHIBITED AND ANY INFRINGEMENT THEREUPON MAY BE SUBJECT TO LEGAL ACTION.	PROJECT MGR: WSM	DATE: 6-25-19	SCALE: NTS	JOB NO: 18315S/19179S	
	CLIENT: NC CARPORTS	SHT. 2	DWG. NO: SK-3	REV: 1	

INSTALLATION NOTES AND SPECIFICATIONS

1. DESIGN IS FOR MAXIMUM 30'-0" WIDE x 16'-0" EAVE HEIGHT ENCLOSED STRUCTURES.
2. DESIGN WAS DONE IN ACCORDANCE WITH THE 2018 NORTH CAROLINA BUILDING CODE, 2009 INTERNATIONAL BUILDING CODE (IBC), 2012 IBC AND 2015 IBC.
3. DESIGN LOADS ARE AS FOLLOWS:
 - A) DEAD LOAD = 1.5 PSF
 - B) LIVE LOAD = 12 PSF
 - C) GROUND SNOW LOAD = 35 PSF
= 30 PSF (W ≤ 24'-0" WITH U-CHANNEL COLLAR TIE)
4. 3-SECOND GUST ULTIMATE WIND SPEED (V_{ULT}) 105 TO 145 MPH (NOMINAL WIND SPEED 82 TO 112 MPH).
5. MAXIMUM RAFTER/COLUMN AND END COLUMN SPACING = 5.0 FEET (UNLESS NOTED OTHERWISE).
6. SIDEWALL COLUMNS AND ENDWALL COLUMNS ARE SIMILAR IN SIZE, UNLESS NOTED OTHERWISE.
7. RISK CATEGORY I.
8. WIND EXPOSURE CATEGORY B.
9. SPECIFICATIONS APPLICABLE TO 29 GAUGE METAL PANELS FASTENED DIRECTLY TO 2 1/2" x 2 1/2" - 14 GAUGE TUBE STEEL (TS) FRAMING MEMBERS (UNLESS NOTED OTHERWISE).
10. AVERAGE FASTENER SPACING ON-CENTERS ALONG RAFTERS OR HAT CHANNELS, AND COLUMNS (INTERIOR OR END) = 9 INCHES.
11. FASTENERS CONSIST OF #12-14x3/4" SELF-DRILLING FASTENER (SDF), USE CONTROL SEAL WASHER WITH EXTERIOR FASTENERS. SPECIFICATIONS APPLICABLE ONLY FOR MEAN ROOF HEIGHT OF 16 FEET OR LESS, AND ROOF SLOPES OF 14° (3:12 PITCH) OR LESS SPACING REQUIREMENTS FOR OTHER ROOF HEIGHTS AND/OR SLOPES MAY VARY.
12. ANCHORS SHALL BE INSTALLED THROUGH BASE RAIL WITHIN 6" OF EACH COLUMN.
13. STANDARD GROUND ANCHORS (SOIL NAILS) CONSIST OF #4 REBAR W/WELDED NUT 30" LONG. SOIL NAILS MAY BE USED FOR WIND SPEEDS < 145 MPH AND IN SUITABLE SOIL CONDITIONS. OPTIONAL ANCHORAGE MAY BE USED IN SUITABLE SOILS AND MUST BE USED FOR WIND SPEEDS > 145 MPH AND/OR IN SUITABLE SOILS AS NOTED.
14. WIND FORCES GOVERN OVER SEISMIC FORCES. SEISMIC PARAMETERS ANALYZED ARE:
 - SOIL SITE CLASS = D
 - RISK CATEGORY I/II/III
 - R = 3.25 I_E = 1.0
 - S_{DS} = 2.039 V = C_sW
 - S_{D1} = 1.258

**MOORE AND ASSOCIATES
ENGINEERING AND CONSULTING, INC.**

DRAWN BY: JG

CHECKED BY: PH

PROJECT MGR: WSM

CLIENT: NC CARPORTS

NC CARPORTS AND GARAGES, LLC
309 S. DEPOT STREET
PILOT MOUNTAIN, NC 27041
30'-0"x16'-0" ENCLOSED STRUCTURE

DATE: 6-25-19

SCALE: NTS

**JOB NO:
183155/19179S**

SHT. 3A

DWG. NO: SK-3

REV: 1

THIS DOCUMENT IS THE PROPERTY OF MOORE AND ASSOCIATES ENGINEERING AND CONSULTING. THE UNAUTHORIZED REPRODUCTION, COPYING, OR OTHERWISE USE OF THIS DOCUMENT IS STRICTLY PROHIBITED AND ANY INFRINGEMENT THEREUPON MAY BE SUBJECT TO LEGAL ACTION.

BOX EAVE FRAME RAFTER STRUCTURE

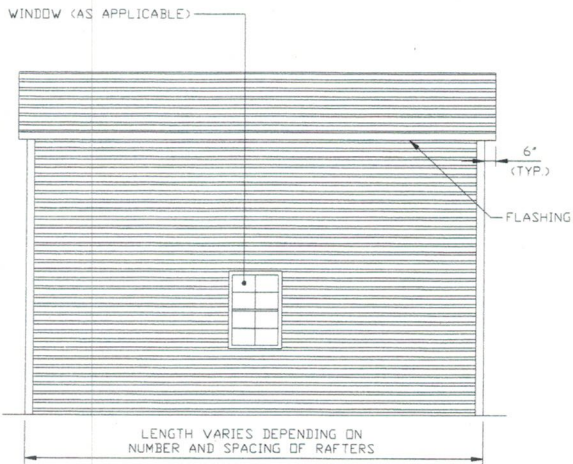

TYPICAL SIDE ELEVATION
SCALE: NTS

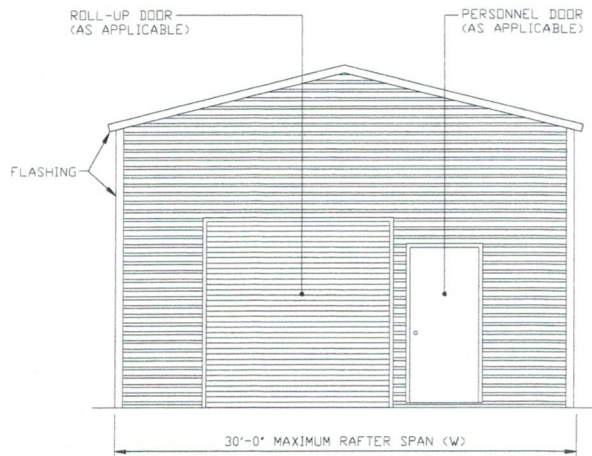

TYPICAL END ELEVATION
SCALE: NTS

**MOORE AND ASSOCIATES
ENGINEERING AND CONSULTING, INC.**

DRAWN BY: JG

CHECKED BY: PH

PROJECT MGR: WSM

CLIENT: NC CARPORTS

NC CARPORTS AND GARAGES, LLC
309 S. DEPOT STREET
PILOT MOUNTAIN, NC 27041
30'-0" x 16'-0" ENCLOSED STRUCTURE

DATE: 6-25-19

SHT. 3B

SCALE: NTS

DWG. NO: SK-3

JOB NO:
18315S/19179S

REV: 1

THIS DOCUMENT IS THE PROPERTY OF MOORE AND ASSOCIATES ENGINEERING AND CONSULTING. THE UNAUTHORIZED REPRODUCTION, COPYING, OR OTHERWISE USE OF THIS DOCUMENT IS STRICTLY PROHIBITED AND ANY INFRINGEMENT THEREUPON MAY BE SUBJECT TO LEGAL ACTION.

BOW EAVE FRAME RAFTER STRUCTURE

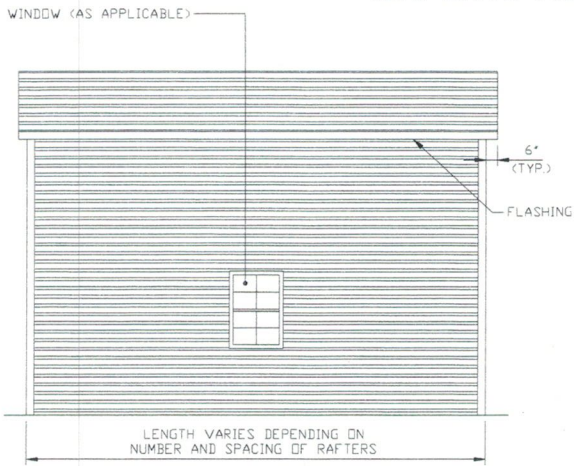

TYPICAL SIDE ELEVATION
SCALE: NTS

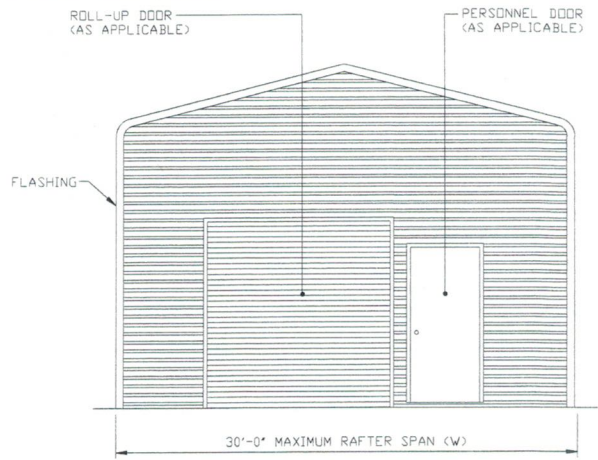

TYPICAL END ELEVATION
SCALE: NTS

**MOORE AND ASSOCIATES
ENGINEERING AND CONSULTING, INC.**

DRAWN BY: JG

CHECKED BY: PH

PROJECT MGR: WSM

CLIENT: NC CARPORTS

NC CARPORTS AND GARAGES, LLC
309 S. DEPOT STREET
PILOT MOUNTAIN, NC 27041
30'-0" x 16'-0" ENCLOSED STRUCTURE

DATE: 6-25-19

SCALE: NTS

JOB NO:
183155/19179S

SHT. 3C

DWG. NO: SK-3

REV: 1

THIS DOCUMENT IS THE PROPERTY OF MOORE AND ASSOCIATES ENGINEERING AND CONSULTING. THE UNAUTHORIZED REPRODUCTION, COPYING, OR OTHERWISE USE OF THIS DOCUMENT IS STRICTLY PROHIBITED AND ANY INFRINGEMENT THEREUPON MAY BE SUBJECT TO LEGAL ACTION.

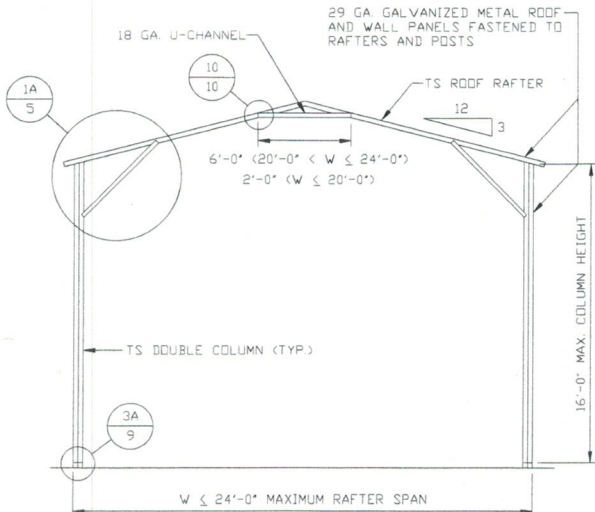

TYPICAL RAFTER/COLUMN FRAME SECTION
SCALE: NTS

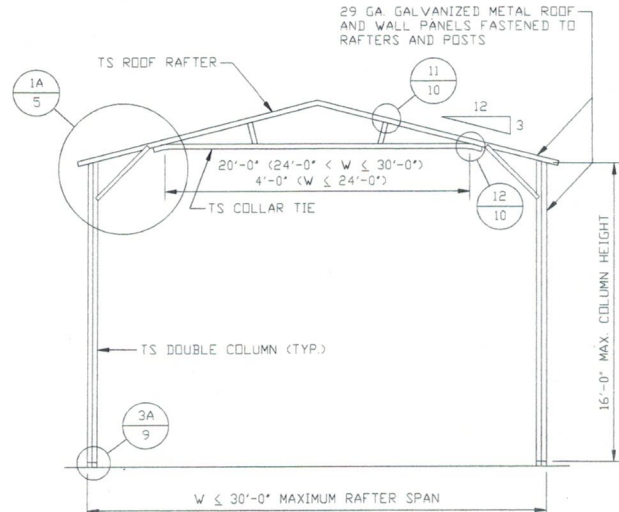

TYPICAL RAFTER/COLUMN FRAME SECTION
SCALE: NTS

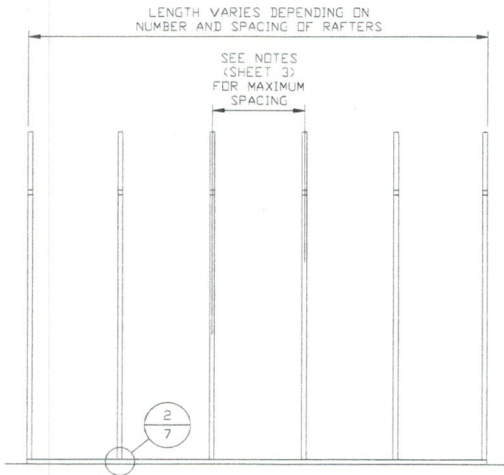

TYPICAL RAFTER/COLUMN SIDE FRAMING SECTION
SCALE: NTS

**MOORE AND ASSOCIATES
ENGINEERING AND CONSULTING, INC.**

THIS DOCUMENT IS THE PROPERTY OF MOORE AND ASSOCIATES ENGINEERING AND CONSULTING. THE UNAUTHORIZED REPRODUCTION, COPYING, OR OTHERWISE USE OF THIS DOCUMENT IS STRICTLY PROHIBITED AND ANY INFRINGEMENT THEREUPON MAY BE SUBJECT TO LEGAL ACTION.

DRAWN BY: JG		NC CARPORTS AND GARAGES, LLC 309 S. DEPOT STREET PILOT MOUNTAIN, NC 27041 30'-0" x 16'-0" ENCLOSED STRUCTURE		
CHECKED BY: PH				
PROJECT MGR: WSM	DATE: 6-25-19	SCALE: NTS	JOB NO: 18315S/19179S	
CLIENT: NC CARPORTS	SHT. 4	DWG. NO: SK-3	REV: 1	

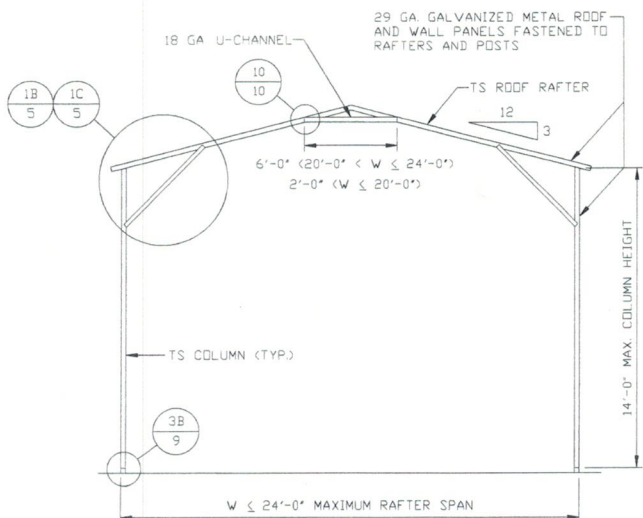

TYPICAL RAFTER/COLUMN FRAME SECTION
SCALE: NTS

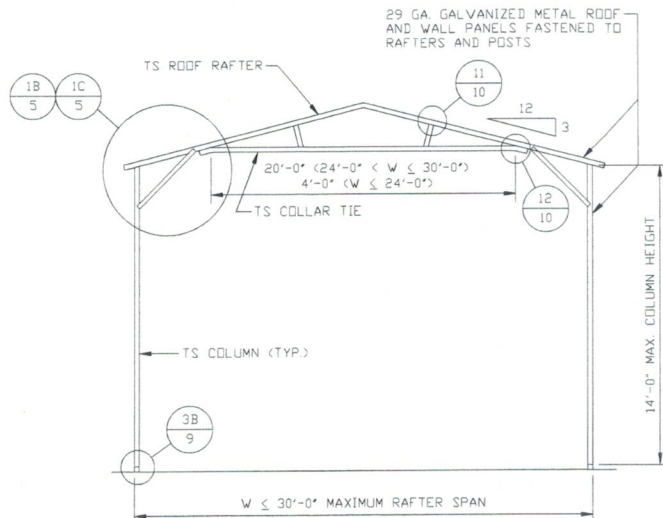

TYPICAL RAFTER/COLUMN FRAME SECTION
SCALE: NTS

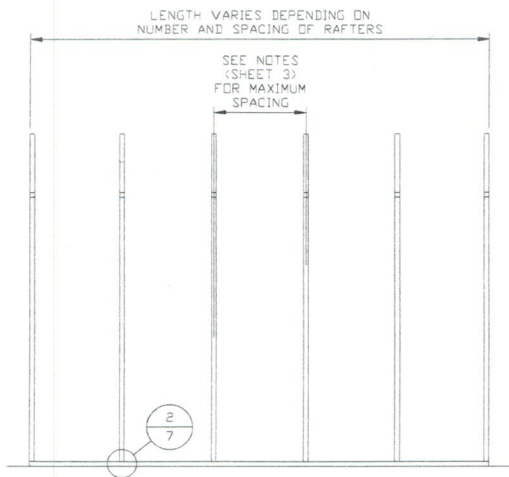

TYPICAL RAFTER/COLUMN SIDE FRAMING SECTION
SCALE: NTS

**MOORE AND ASSOCIATES
ENGINEERING AND CONSULTING, INC.**

THIS DOCUMENT IS THE PROPERTY OF MOORE AND ASSOCIATES ENGINEERING AND CONSULTING. THE UNAUTHORIZED REPRODUCTION, COPYING, OR OTHERWISE USE OF THIS DOCUMENT IS STRICTLY PROHIBITED AND ANY INFRINGEMENT THEREUPON MAY BE SUBJECT TO LEGAL ACTION.

DRAWN BY: JG

CHECKED BY: PH

PROJECT MGR: WSM

CLIENT: NC CARPORTS

NC CARPORTS AND GARAGES, LLC
309 S. DEPOT STREET
PILOT MOUNTAIN, NC 27041
30'-0" x 16'-0" ENCLOSED STRUCTURE

DATE: 6-25-19

SHT. 4A

SCALE: NTS

DWG. NO: SK-3

JOB NO:

18315S/19179S

REV: 1

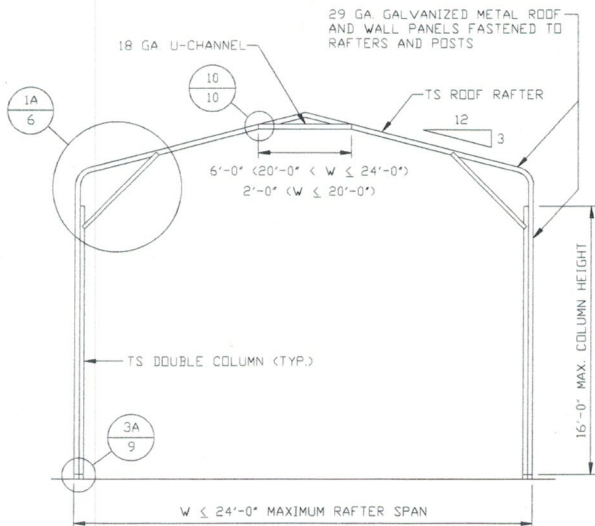

TYPICAL RAFTER/COLUMN FRAME SECTION
SCALE: NTS

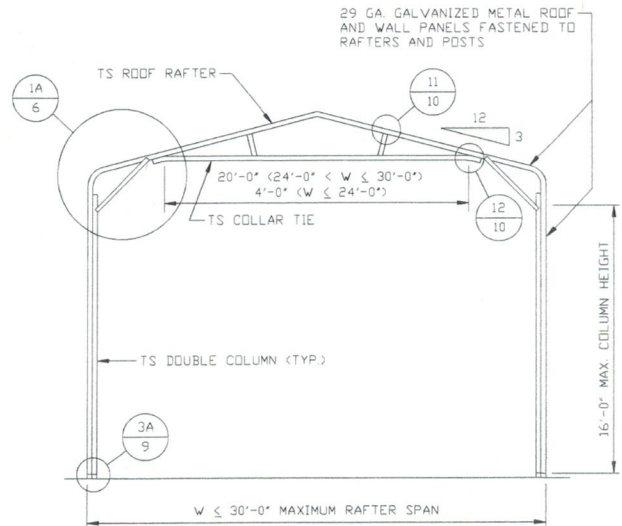

TYPICAL RAFTER/COLUMN FRAME SECTION
SCALE: NTS

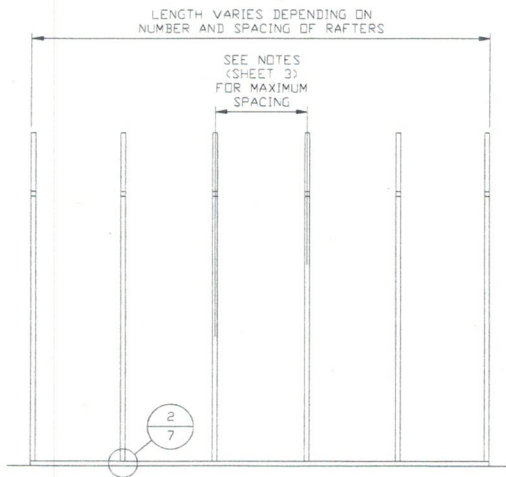

TYPICAL RAFTER/COLUMN SIDE FRAMING SECTION
SCALE: NTS

**MOORE AND ASSOCIATES
ENGINEERING AND CONSULTING, INC.**

DRAWN BY: JG
CHECKED BY: PH
PROJECT MGR: WSM
CLIENT: NC CARPORTS

NC CARPORTS AND GARAGES, LLC
309 S. DEPOT STREET
PILOT MOUNTAIN, NC 27041
30'-0" x 16'-0" ENCLOSED STRUCTURE
DATE: 6-25-19
SCALE: NTS
JOB NO: 18315S/19179S
SHT. 4B
DWG. NO: SK-3
REV: 1

THIS DOCUMENT IS THE PROPERTY OF MOORE AND ASSOCIATES ENGINEERING AND CONSULTING. THE UNAUTHORIZED REPRODUCTION, COPYING, OR OTHERWISE USE OF THIS DOCUMENT IS STRICTLY PROHIBITED AND ANY INFRINGEMENT THEREUPON MAY BE SUBJECT TO LEGAL ACTION.

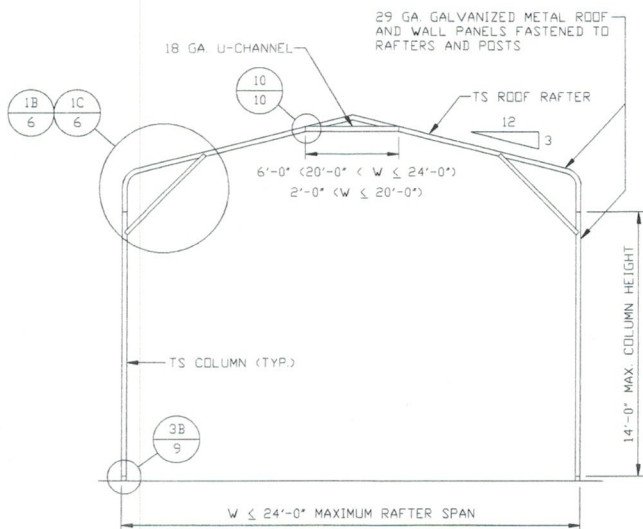

TYPICAL RAFTER/COLUMN FRAME SECTION

SCALE: NTS

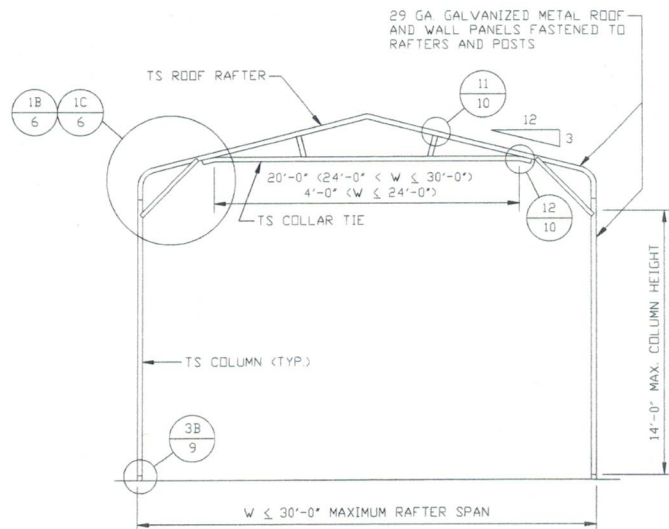

TYPICAL RAFTER/COLUMN FRAME SECTION

SCALE: NTS

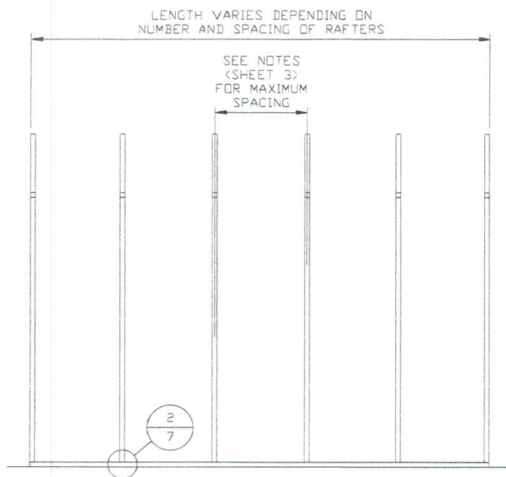

TYPICAL RAFTER/COLUMN SIDE FRAMING SECTION

SCALE: NTS

**MOORE AND ASSOCIATES
ENGINEERING AND CONSULTING, INC.**

DRAWN BY: JG

CHECKED BY: PH

PROJECT MGR: WSM

CLIENT: NC CARPORTS

NC CARPORTS AND GARAGES, LLC
309 S. DEPOT STREET
PILOT MOUNTAIN, NC 27041
30'-0" x 16'-0" ENCLOSED STRUCTURE

DATE: 6-25-19

SCALE: NTS

JOB NO:
18315S/19179S

SHT. 4C

DWG. NO: SK-3

REV: 1

THIS DOCUMENT IS THE PROPERTY OF MOORE AND ASSOCIATES ENGINEERING AND CONSULTING. THE UNAUTHORIZED REPRODUCTION, COPYING, OR OTHERWISE USE OF THIS DOCUMENT IS STRICTLY PROHIBITED AND ANY INFRINGEMENT THEREUPON MAY BE SUBJECT TO LEGAL ACTION.

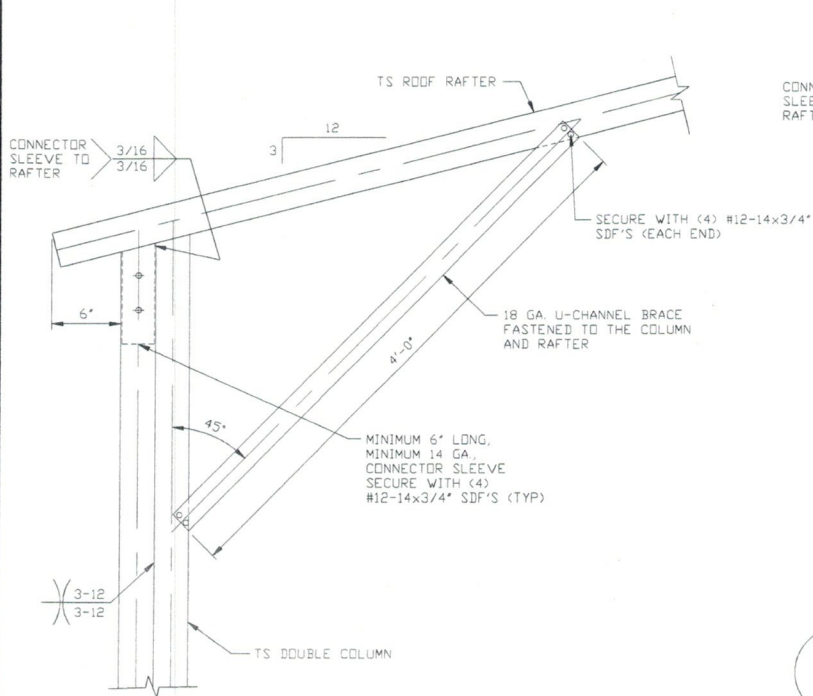

1A

BOX EAVE RAFTER/CORNER POST CONNECTION DETAIL FOR HEIGHTS 14'-0" < TO <= 16'-0"

SCALE: NTS

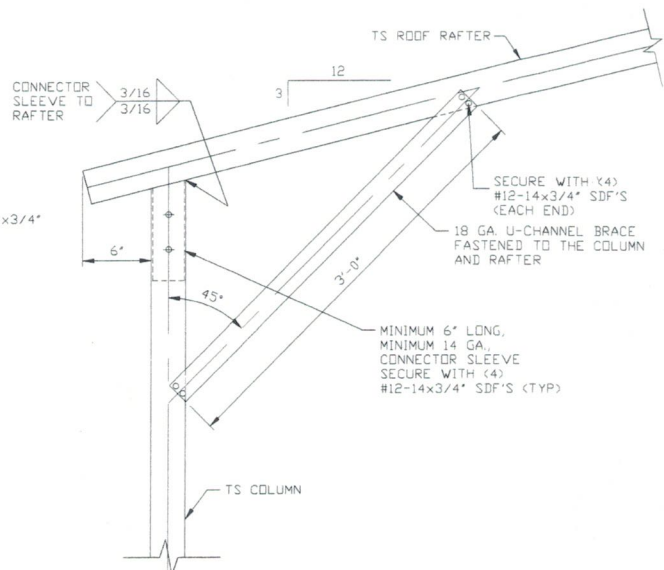

1C

BOX EAVE RAFTER/CORNER POST CONNECTION DETAIL FOR HEIGHTS <= 12'-0"

SCALE: NTS

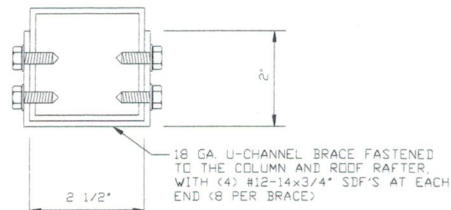

BRACE SECTION

SCALE: NTS

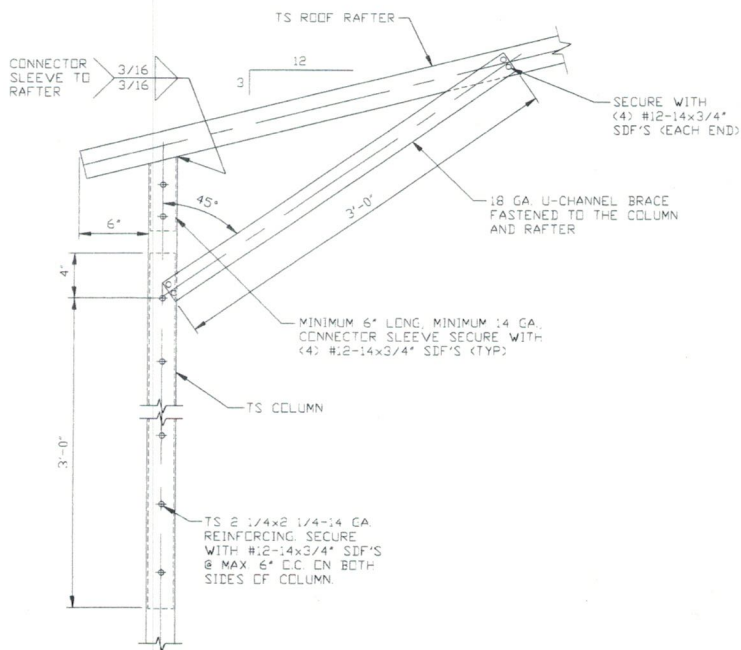

1B

BOX EAVE RAFTER/CORNER POST CONNECTION DETAIL FOR HEIGHTS 12'-0" < TO <= 14'-0"

SCALE: NTS

MOORE AND ASSOCIATES ENGINEERING AND CONSULTING, INC.

DRAWN BY: JG		NC CARPORTS AND GARAGES, LLC		
CHECKED BY: PH		309 S. DEPOT STREET		
PROJECT MGR: WSM		PILOT MOUNTAIN, NC 27041		
DATE: 6-25-19		SCALE: NTS		JOB NO: 18315S/19179S
CLIENT: NC CARPORTS		SHT. 5	DWG. NO: SK-3	REV: 1

THIS DOCUMENT IS THE PROPERTY OF MOORE AND ASSOCIATES ENGINEERING AND CONSULTING. THE UNAUTHORIZED REPRODUCTION, COPYING, OR OTHERWISE USE OF THIS DOCUMENT IS STRICTLY PROHIBITED AND ANY INFRINGEMENT THEREUPON MAY BE SUBJECT TO LEGAL ACTION.

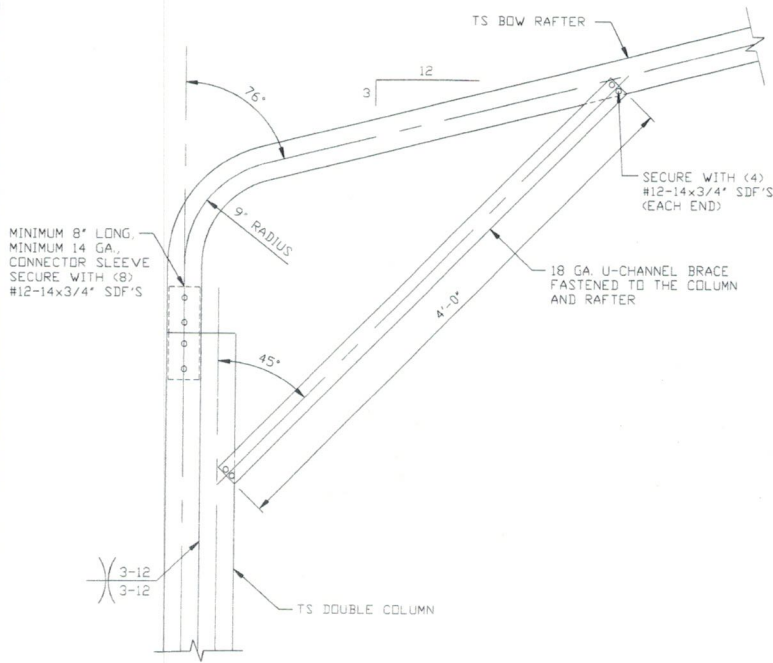

1A

BOX EAVE RAFTER/CORNER POST CONNECTION DETAIL FOR HEIGHTS 14'-0" < TO <= 16'-0"

SCALE: NTS

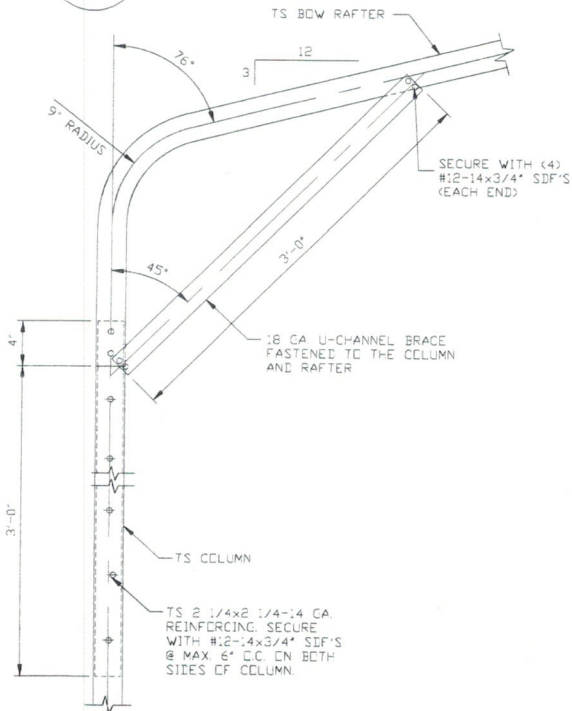

1B

BOW RAFTER/CORNER POST CONNECTION DETAIL FOR HEIGHTS 12'-0" < TO <= 14'-0"

SCALE: NTS

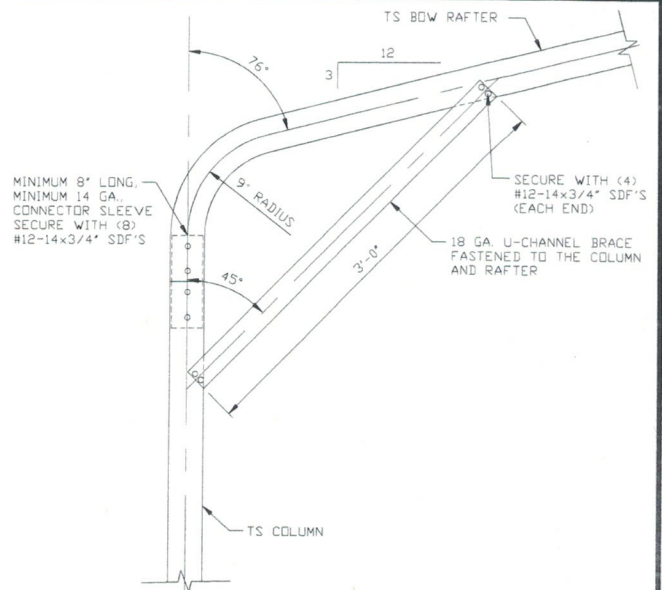

1C

BOX EAVE RAFTER/CORNER POST CONNECTION DETAIL FOR HEIGHTS <= 12'-0"

SCALE: NTS

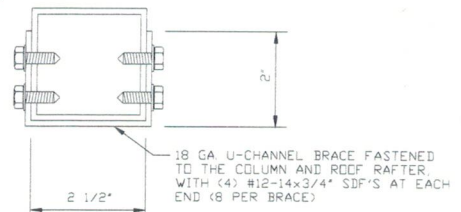

BRACE SECTION

SCALE: NTS

MOORE AND ASSOCIATES ENGINEERING AND CONSULTING, INC.

THIS DOCUMENT IS THE PROPERTY OF MOORE AND ASSOCIATES ENGINEERING AND CONSULTING. THE UNAUTHORIZED REPRODUCTION, COPYING, OR OTHERWISE USE OF THIS DOCUMENT IS STRICTLY PROHIBITED AND ANY INFRINGEMENT THEREUPON MAY BE SUBJECT TO LEGAL ACTION.

DRAWN BY: JG

CHECKED BY: PH

PROJECT MGR: WSM

CLIENT: NC CARPORTS

NC CARPORTS AND GARAGES, LLC
309 S. DEPOT STREET
PILOT MOUNTAIN, NC 27041
30'-0" x 16'-0" ENCLOSED STRUCTURE

DATE: 6-25-19

SHT. 6

SCALE: NTS

DWG. NO: SK-3

JOB NO:
18315S/19179S

REV: 1

BASE RAIL ANCHORAGE OPTIONS

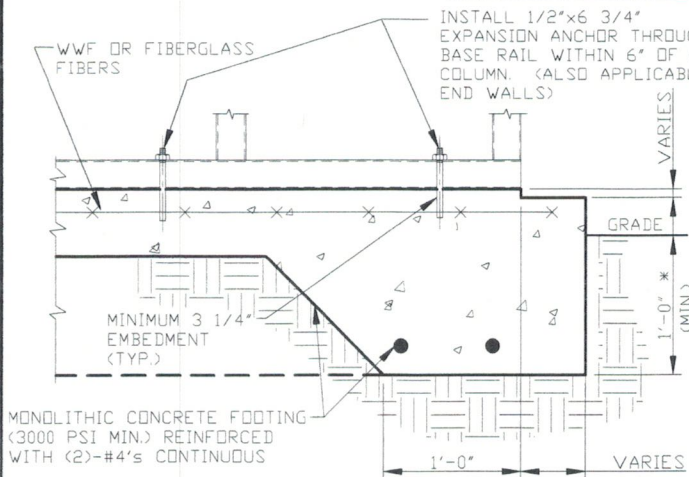

2A

CONCRETE MONOLITHIC SLAB BASE RAIL ANCHORAGE

SCALE: NTS
MINIMUM ANCHOR EDGE DISTANCE IS 4".
* COORDINATE WITH LOCAL CODES/ORD.

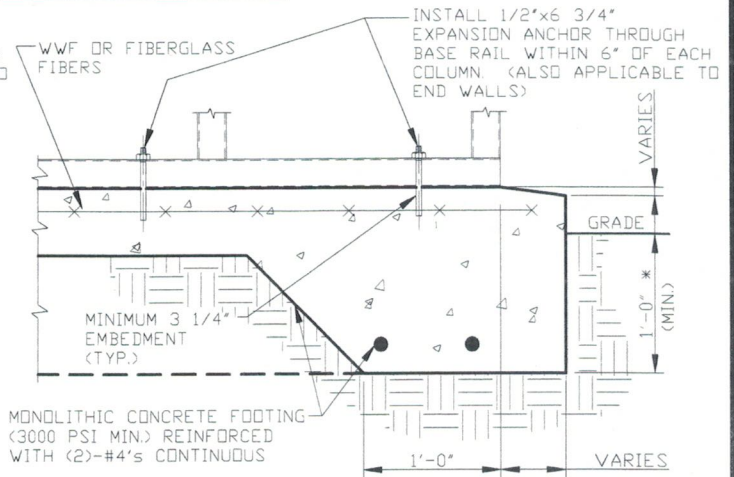

2B

CONCRETE MONOLITHIC SLAB BASE RAIL ANCHORAGE

SCALE: NTS
MINIMUM ANCHOR EDGE DISTANCE IS 4".
* COORDINATE WITH LOCAL CODES/ORD.

GENERAL NOTES

NOTE: CONCRETE MONOLITHIC SLAB DESIGN BASED ON MINIMUM SOIL BEARING CAPACITY OF 1,500 PSF.

CONCRETE:

CONCRETE SHALL HAVE A MINIMUM SPECIFIED COMPRESSIVE STRENGTH OF 3,000 PSI AT 28 DAYS.

COVER OVER REINFORCING STEEL:

FOR FOUNDATIONS, MINIMUM CONCRETE COVER OVER REINFORCING BARS SHALL BE PER ACI-318.

3" IN FOUNDATIONS WHERE THE CONCRETE IS CAST AGAINST AND PERMANENTLY IN CONTACT WITH THE EARTH OR WEATHER, AND 1 1/2" ELSEWHERE.

REINFORCING STEEL:

THE TURNDOWN REINFORCING STEEL SHALL BE ASTM A615 GRADE 60. THE SLAB REINFORCEMENT SHALL BE WELDED WIRE FABRIC MEETING ASTM A185 OR FIBERGLASS FIBER REINFORCEMENT.

REINFORCEMENT MAY BE BENT IN THE SHOP OR THE FIELD PROVIDED:

1. REINFORCEMENT IS BENT COLD.
2. THE DIAMETER OF THE BEND, MEASURED ON THE INSIDE OF THE BAR, IS NOT LESS THAN SIX-BAR DIAMETERS.
3. REINFORCEMENT PARTIALLY EMBEDDED IN CONCRETE SHALL NOT BE FIELD BENT.

HELIX ANCHOR NOTES:

1. FOR VERY DENSE AND/OR CEMENTED SANDS, COARSE GRAVEL AND COBBLES, CALICHE, PRELOADED SILTS AND CLAYS, USE: MINIMUM (2) 4" HELICES WITH MINIMUM 30" EMBEDMENT OR SINGLE 6" HELIX WITH MINIMUM 50" EMBEDMENT.
2. FOR CORAL USE MINIMUM (2) 4" HELICES WITH MINIMUM 30" EMBEDMENT OR SINGLE 6" HELIX WITH MINIMUM 50" EMBEDMENT.
3. FOR MEDIUM DENSE COARSE SANDS, SANDY GRAVELS, VERY STIFF SILTS, AND CLAYS USE MINIMUM (2) 4" HELICES WITH MINIMUM 30" INCH EMBEDMENT OR SINGLE 6" HELIX WITH MINIMUM 50" EMBEDMENT.
4. FOR LOOSE TO MEDIUM DENSE SANDS, FIRM TO STIFF CLAYS AND SILTS ALLUVIAL FILL, USE MINIMUM (2) 6" HELICES WITH MINIMUM 50" EMBEDMENT.
5. FOR VERY LOSE TO MEDIUM DENSE SANDS, FIRM TO STIFFER CLAYS AND SILTS ALLUVIAL FILL, USE MINIMUM (2) 8" HELICES WITH MINIMUM 60" EMBEDMENT.

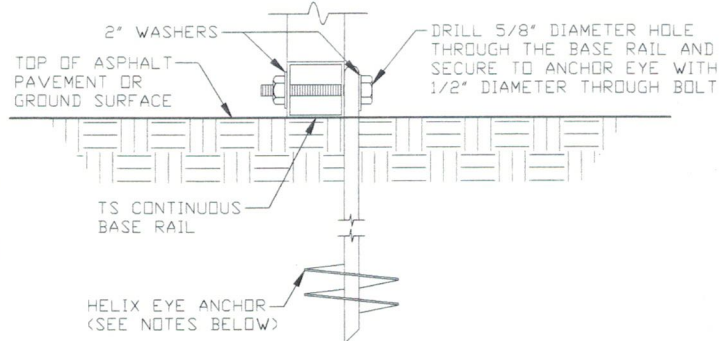

2C

GROUND BASE HELIX ANCHORAGE

SCALE: NTS
(CAN BE USED FOR ASPHALT)

**MOORE AND ASSOCIATES
ENGINEERING AND CONSULTING, INC.**

DRAWN BY: JG

CHECKED BY: PH

PROJECT MGR: WSM

CLIENT: NC CARPORTS

NC CARPORTS AND GARAGES, LLC
309 S. DEPOT STREET
PILOT MOUNTAIN, NC 27041
30'-0" x 16'-0" ENCLOSED STRUCTURE

DATE: 6-25-19

SHT. 7

SCALE: NTS

DWG. NO: SK-3

JOB NO:
18315S/19179S

REV: 1

THIS DOCUMENT IS THE PROPERTY OF MOORE AND ASSOCIATES ENGINEERING AND CONSULTING. THE UNAUTHORIZED REPRODUCTION, COPYING, OR OTHERWISE USE OF THIS DOCUMENT IS STRICTLY PROHIBITED AND ANY INFRINGEMENT THEREUPON MAY BE SUBJECT TO LEGAL ACTION.

BASE RAIL ANCHORAGE OPTIONS

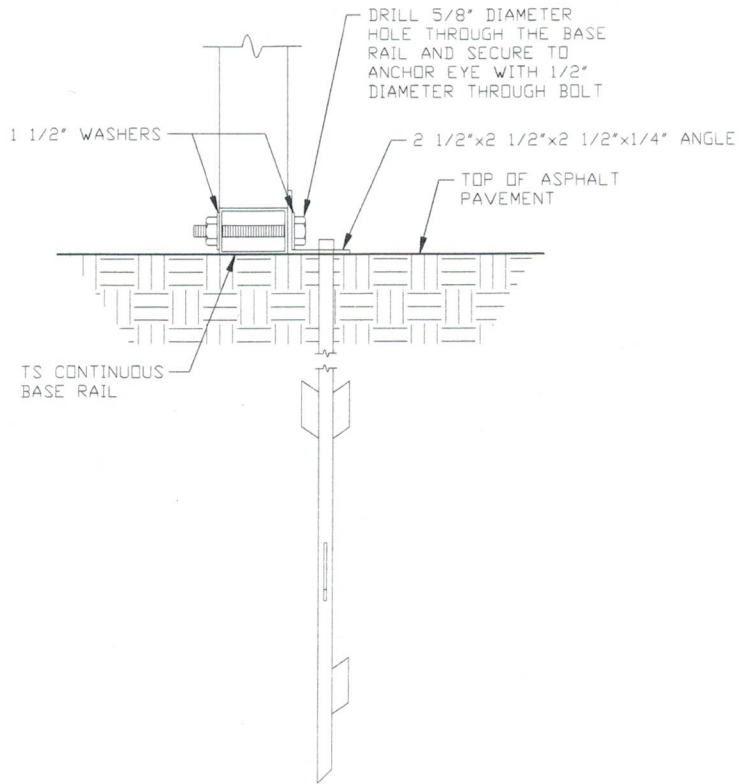

2D

ASPHALT BASE ANCHORAGE
SCALE: NTS

**MOORE AND ASSOCIATES
ENGINEERING AND CONSULTING, INC.**

DRAWN BY: JG

CHECKED BY: PH

PROJECT MGR: WSM

CLIENT: NC CARPORTS

NC CARPORTS AND GARAGES, LLC
309 S. DEPOT STREET
PILOT MOUNTAIN, NC 27041
30'-0" x 16'-0" ENCLOSED STRUCTURE

DATE: 6-25-19

SCALE: NTS

JOB NO:
18315S/19179S

SHT. 7A

DWG. NO: SK-3

REV: 1

THIS DOCUMENT IS THE PROPERTY OF MOORE AND ASSOCIATES ENGINEERING AND CONSULTING. THE UNAUTHORIZED REPRODUCTION, COPYING, OR OTHERWISE USE OF THIS DOCUMENT IS STRICTLY PROHIBITED AND ANY INFRINGEMENT THEREUPON MAY BE SUBJECT TO LEGAL ACTION.

BOX EAVE RAFTER END WALL AND SIDE WALL OPENINGS

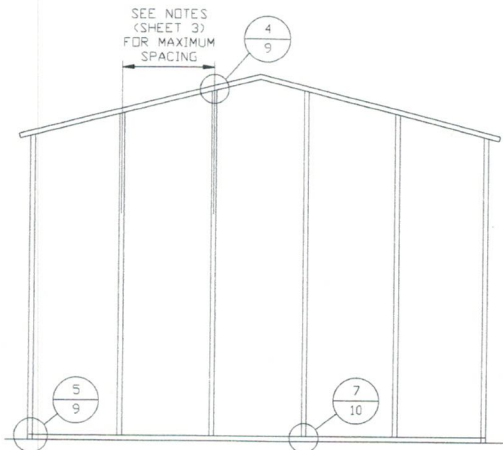

**TYPICAL BOX EAVE RAFTER
END WALL FRAMING SECTION**

SCALE: NTS

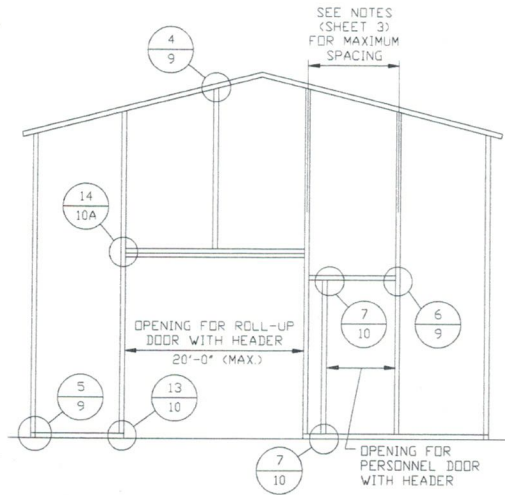

**TYPICAL BOX EAVE RAFTER END
WALL OPENINGS FRAMING SECTION**

SCALE: NTS

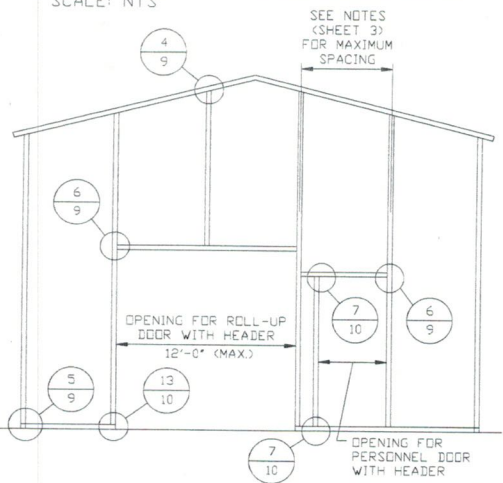

**TYPICAL BOX EAVE RAFTER END
WALL OPENINGS FRAMING SECTION**

SCALE: NTS

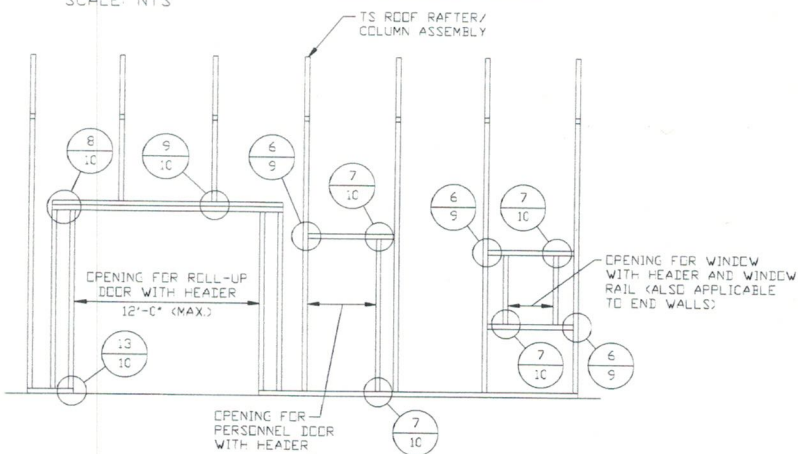

**TYPICAL BOX EAVE RAFTER
SIDE WALL OPENINGS FRAMING SECTION**

SCALE: NTS

**MOORE AND ASSOCIATES
ENGINEERING AND CONSULTING, INC.**

DRAWN BY: JG		NC CARPORTS AND GARAGES, LLC 309 S. DEPOT STREET PILOT MOUNTAIN, NC 27041 30'-0" x 16'-0" ENCLOSED STRUCTURE	
CHECKED BY: PH			
PROJECT MGR: WSM	DATE: 6-25-19	SCALE: NTS	JOB NO: 183155/19179S
CLIENT: NC CARPORTS	SHT. 8	DWG. NO: SK-3	REV: 1

THIS DOCUMENT IS THE PROPERTY OF MOORE AND ASSOCIATES ENGINEERING AND CONSULTING. THE UNAUTHORIZED REPRODUCTION, COPYING, OR OTHERWISE USE OF THIS DOCUMENT IS STRICTLY PROHIBITED AND ANY INFRINGEMENT THEREUPON MAY BE SUBJECT TO LEGAL ACTION.

BOX EAVE RAFTER END WALL AND SIDE WALL OPENINGS

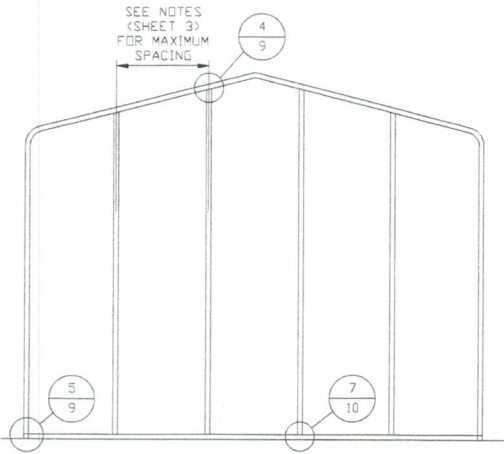

**TYPICAL BOX EAVE RAFTER
END WALL FRAMING SECTION**

SCALE: NTS

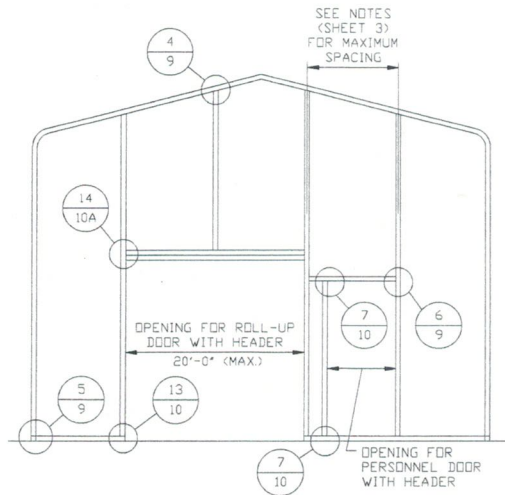

**TYPICAL BOX EAVE RAFTER END
WALL OPENINGS FRAMING SECTION**

SCALE: NTS

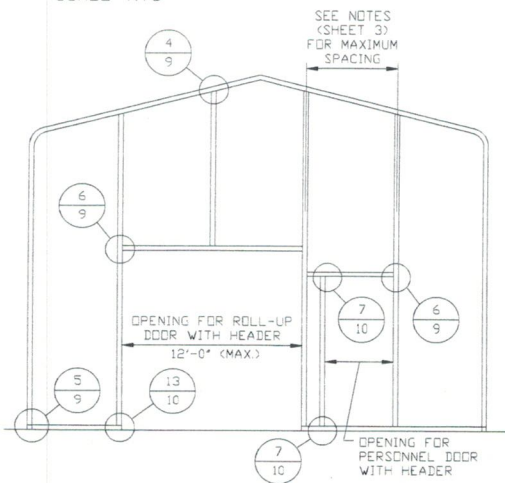

**TYPICAL BOX EAVE RAFTER END
WALL OPENINGS FRAMING SECTION**

SCALE: NTS

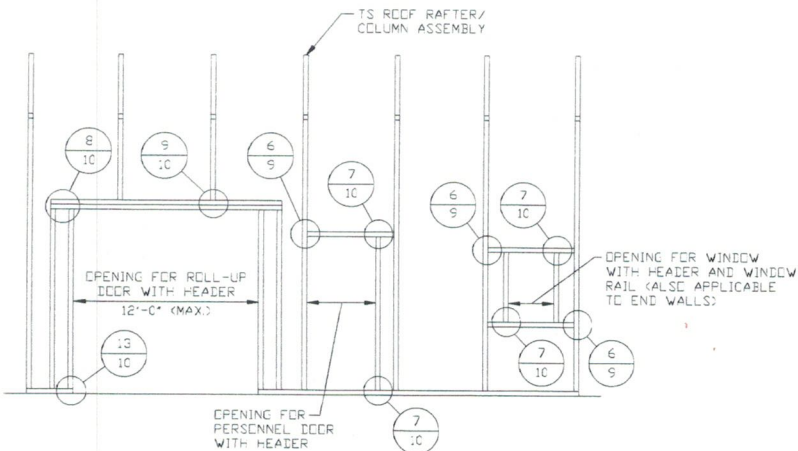

**TYPICAL BOX EAVE RAFTER
SIDE WALL OPENINGS FRAMING SECTION**

SCALE: NTS

**MOORE AND ASSOCIATES
ENGINEERING AND CONSULTING, INC.**

DRAWN BY: JG		NC CARPORTS AND GARAGES, LLC 309 S. DEPOT STREET PILOT MOUNTAIN, NC 27041 30'-0" x 16'-0" ENCLOSED STRUCTURE	
CHECKED BY: PH			
PROJECT MGR: WSM	DATE: 6-25-19	SCALE: NTS	JOB NO: 18315S/19179S
CLIENT: NC CARPORTS	SHT. 8A	DWG. NO: SK-3	REV.: 1

THIS DOCUMENT IS THE PROPERTY OF MOORE AND ASSOCIATES ENGINEERING AND CONSULTING. THE UNAUTHORIZED REPRODUCTION, COPYING, OR OTHERWISE USE OF THIS DOCUMENT IS STRICTLY PROHIBITED AND ANY INFRINGEMENT THEREUPON MAY BE SUBJECT TO LEGAL ACTION.

CONNECTION DETAILS

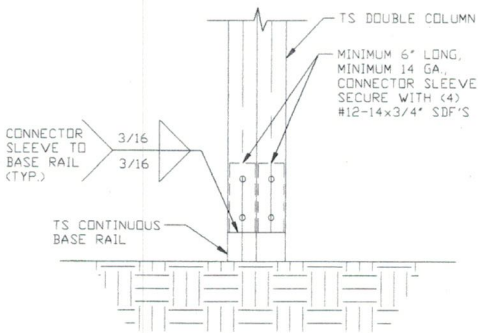

3A
POST/BASE RAIL CONNECTION DETAIL
 SCALE: NTS

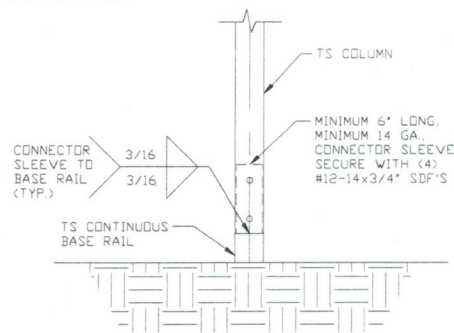

3B
POST/BASE RAIL CONNECTION DETAIL
 SCALE: NTS

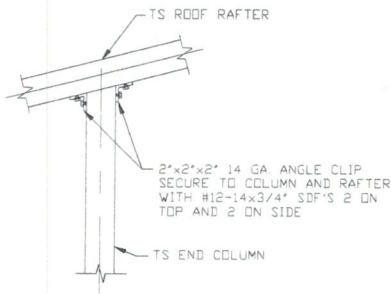

4
END COLUMN/RAFTER CONNECTION DETAIL
 SCALE: NTS

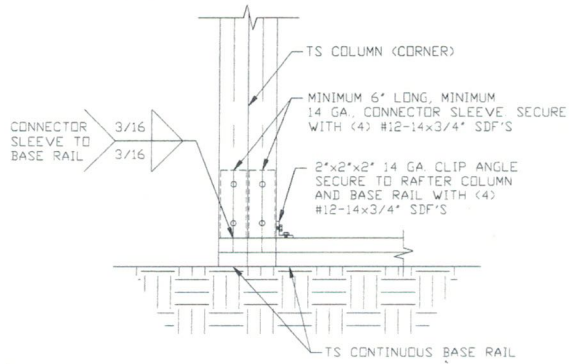

5A
END COLUMN/BASE RAIL CONNECTION DETAIL
 SCALE: NTS

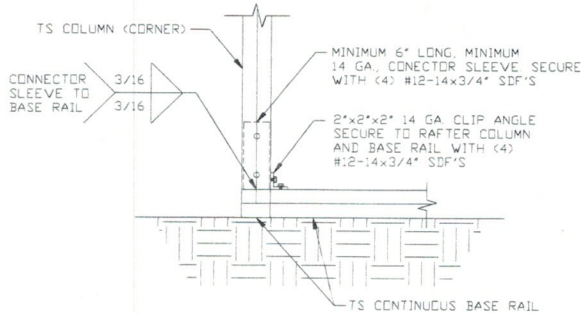

5B
END COLUMN/BASE RAIL CONNECTION DETAIL
 SCALE: NTS

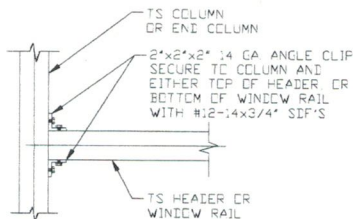

6
COLUMN OR WINDOW RAIL TO POST CONNECTION DETAIL
 SCALE: NTS

**MOORE AND ASSOCIATES
 ENGINEERING AND CONSULTING, INC.**

DRAWN BY: JG

CHECKED BY: PH

PROJECT MGR: WSM

CLIENT: NC CARPORTS

NC CARPORTS AND GARAGES, LLC
 309 S. DEPOT STREET
 PILOT MOUNTAIN, NC 27041
 30'-0" x 16'-0" ENCLOSED STRUCTURE

DATE: 6-25-19

SHT. 9

SCALE: NTS

DWG. NO: SK-3

**JOB NO:
 18315S/19179S**

REV: 1

THIS DOCUMENT IS THE PROPERTY OF MOORE AND ASSOCIATES ENGINEERING AND CONSULTING. THE UNAUTHORIZED REPRODUCTION, COPYING, OR OTHERWISE USE OF THIS DOCUMENT IS STRICTLY PROHIBITED AND ANY INFRINGEMENT THEREUPON MAY BE SUBJECT TO LEGAL ACTION.

CONNECTION DETAILS

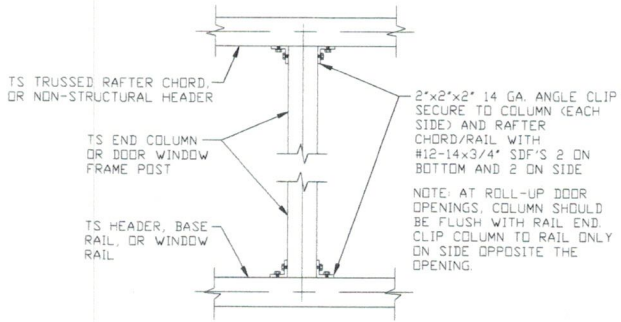

7

COLUMN TO HEADER, BASE RAIL, OR WINDOW RAIL CONNECTION DETAIL

SCALE: NTS

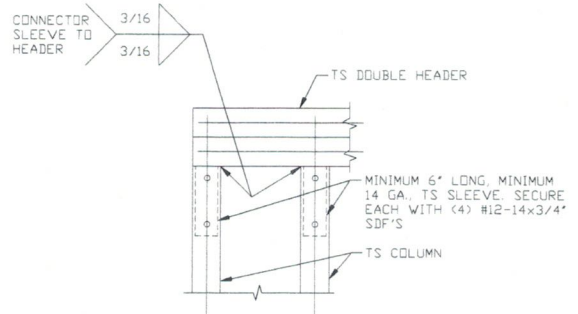

8

DOUBLE HEADER/COLUMN CONNECTION DETAIL

SCALE: NTS

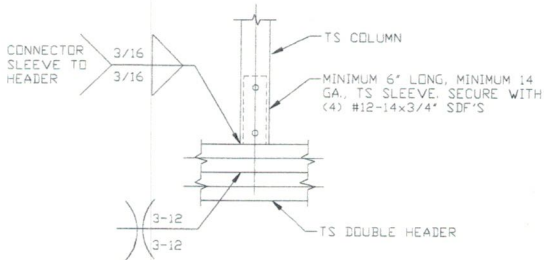

9

COLUMN/DOUBLE HEADER CONNECTION DETAIL

SCALE: NTS

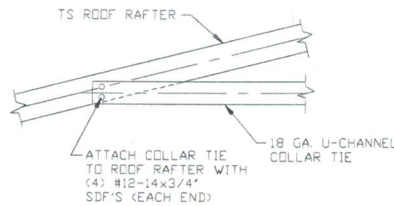

10

COLLAR TIE CONNECTION DETAIL

SCALE: NTS

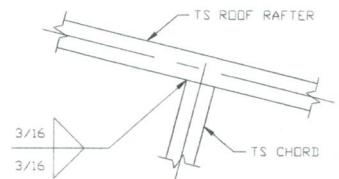

11

RAFTER TO CHORD CONNECTION DETAIL

SCALE: NTS

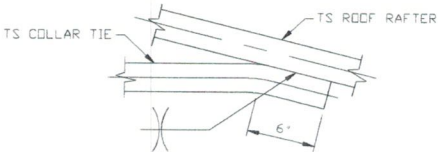

12

COLLAR TIE CONNECTION DETAIL

SCALE: NTS

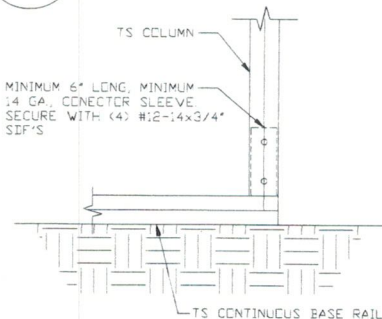

13

COLUMN/BASE RAIL CONNECTION DETAIL

SCALE: NTS

**MOORE AND ASSOCIATES
ENGINEERING AND CONSULTING, INC.**

DRAWN BY: JG

CHECKED BY: PH

PROJECT MGR: WSM

CLIENT: NC CARPORTS

NC CARPORTS AND GARAGES, LLC
309 S. DEPOT STREET
PILOT MOUNTAIN, NC 27041
30'-0"X16'-0" ENCLOSED STRUCTURE

DATE: 6-25-19

SHT. 10

SCALE: NTS

DWG. NO: SK-3

JOB NO:
18315S/19179S

REV: 1

THIS DOCUMENT IS THE PROPERTY OF MOORE AND ASSOCIATES ENGINEERING AND CONSULTING. THE UNAUTHORIZED REPRODUCTION, COPYING, OR OTHERWISE USE OF THIS DOCUMENT IS STRICTLY PROHIBITED AND ANY INFRINGEMENT THEREUPON MAY BE SUBJECT TO LEGAL ACTION.

CONNECTION DETAILS

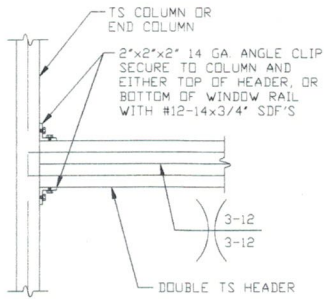

**DOUBLE HEADER TO COLUMN
CONNECTION DETAIL**

14

SCALE: NTS

**MOORE AND ASSOCIATES
ENGINEERING AND CONSULTING, INC.**

DRAWN BY: JG

CHECKED BY: PH

PROJECT MGR: WSM

CLIENT: NC CARPORTS

NC CARPORTS AND GARAGES, LLC
309 S. DEPOT STREET
PILOT MOUNTAIN, NC 27041
30'-0"X16'-0" ENCLOSED STRUCTURE

DATE: 6-25-19

SCALE: NTS

JOB NO:
183155/19179S

SHT. 10A

DWG. NO: SK-3

REV: 1

THIS DOCUMENT IS THE PROPERTY OF MOORE AND ASSOCIATES ENGINEERING AND CONSULTING. THE UNAUTHORIZED REPRODUCTION, COPYING, OR OTHERWISE USE OF THIS DOCUMENT IS STRICTLY PROHIBITED AND ANY INFRINGEMENT THEREUPON MAY BE SUBJECT TO LEGAL ACTION.

BOX EAVE RAFTER LEAN-TO OPTIONS

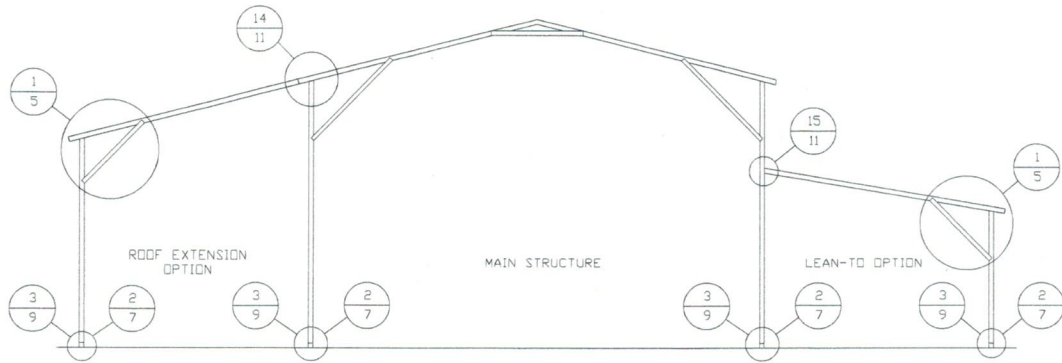

TYPICAL BOX EAVE RAFTER LEAN-TO OPTIONS FRAMING SECTION (BOTH OPTIONS SHOWN)

SCALE: NTS

MAXIMUM WIDTH OF SINGLE MEMBER ROOF EXTENSION AND LEAN-TO OPTION IS 12'-0".
 MAXIMUM WIDTH OF DOUBLE MEMBER ROOF EXTENSION AND LEAN-TO OPTION IS 16'-0".

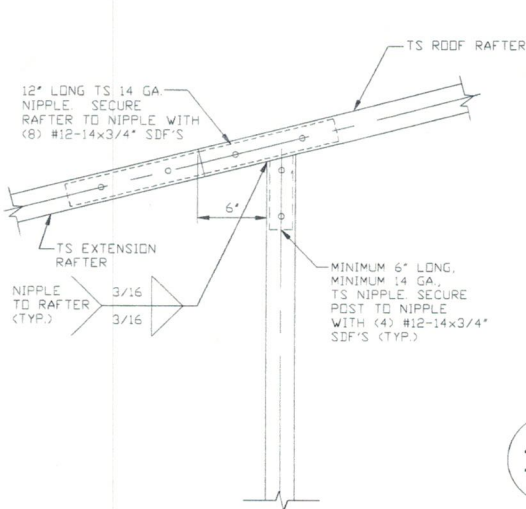

15A

LEAN-TO RAFTER TO RAFTER POST CONNECTION DETAIL FOR WIDTHS $\leq 12'-0''$

SCALE: NTS

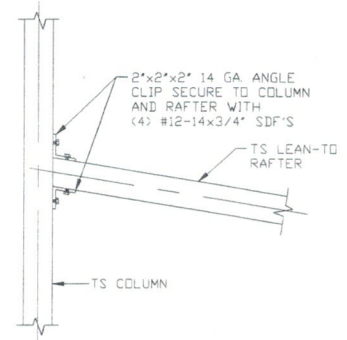

15B

LEAN-TO RAFTER TO RAFTER POST CONNECTION DETAIL FOR WIDTHS $\leq 12'-0''$

SCALE: NTS

14

ROOF EXTENSION RAFTER/CORNER POST DETAIL FOR WIDTHS $\leq 12'-0''$

SCALE: NTS

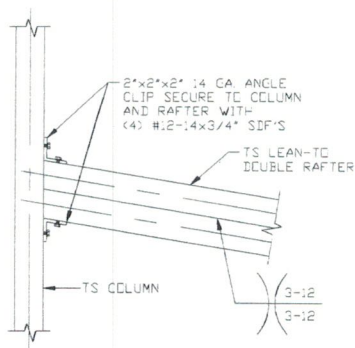

15C

LEAN-TO RAFTER TO RAFTER POST CONNECTION DETAIL FOR WIDTHS $\leq 16'-0''$

SCALE: NTS

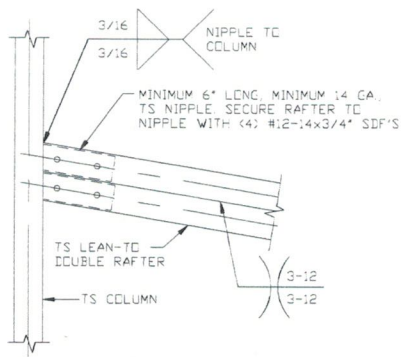

15D

LEAN-TO RAFTER TO RAFTER POST CONNECTION DETAIL FOR WIDTHS $\leq 16'-0''$

SCALE: NTS

**MOORE AND ASSOCIATES
ENGINEERING AND CONSULTING, INC.**

DRAWN BY: JG

CHECKED BY: PH

PROJECT MGR: WSM

CLIENT: NC CARPORTS

NC CARPORTS AND GARAGES, LLC
 309 S. DEPOT STREET
 PILOT MOUNTAIN, NC 27041
 30'-0" x 16'-0" ENCLOSED STRUCTURE

DATE: 6-25-19

SHT. 11

SCALE: NTS

DWG. NO: SK-3

**JOB NO:
18315S/19179S**

REV: 1

THIS DOCUMENT IS THE PROPERTY OF MOORE AND ASSOCIATES ENGINEERING AND CONSULTING. THE UNAUTHORIZED REPRODUCTION, COPYING, OR OTHERWISE USE OF THIS DOCUMENT IS STRICTLY PROHIBITED AND ANY INFRINGEMENT THEREUPON MAY BE SUBJECT TO LEGAL ACTION.

BOW EAVE RAFTER LEAN-TO OPTIONS

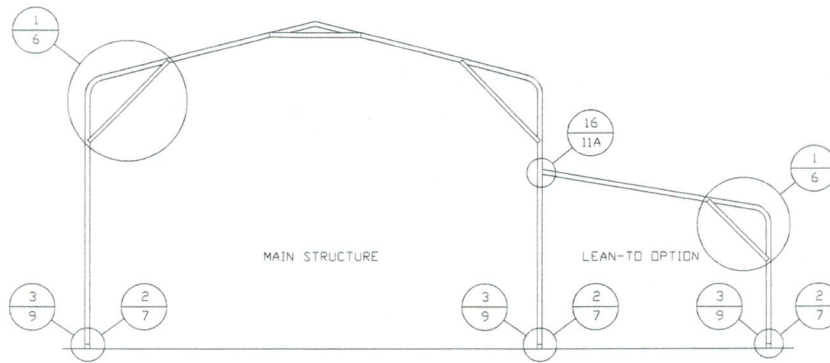

TYPICAL BOW EAVE RAFTER LEAN-TO OPTIONS FRAMING SECTION

SCALE: NTS
 MAXIMUM WIDTH OF SINGLE MEMBER LEAN-TO OPTION IS 12'-0".
 MAXIMUM WIDTH OF DOUBLE MEMBER LEAN-TO OPTION IS 16'-0"

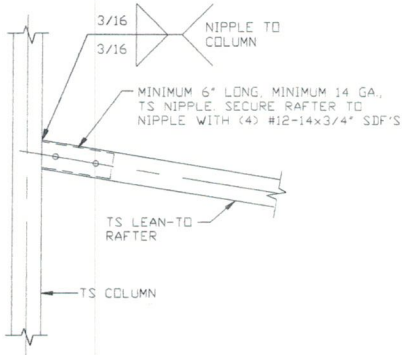

16A

**LEAN-TO RAFTER TO
 RAFTER POST
 CONNECTION DETAIL
 FOR WIDTHS \leq 12'-0"**

SCALE: NTS

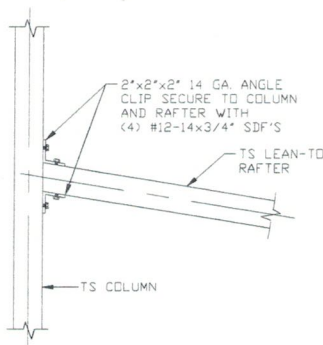

16B

**LEAN-TO RAFTER
 TO RAFTER POST
 CONNECTION DETAIL
 FOR WIDTHS \leq 12'-0"**

SCALE: NTS

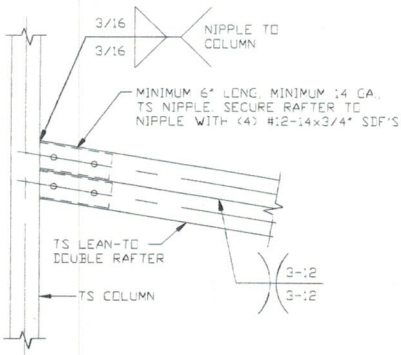

16C

**LEAN-TO RAFTER TO
 RAFTER POST
 CONNECTION DETAIL
 FOR WIDTHS \leq 16'-0"**

SCALE: NTS

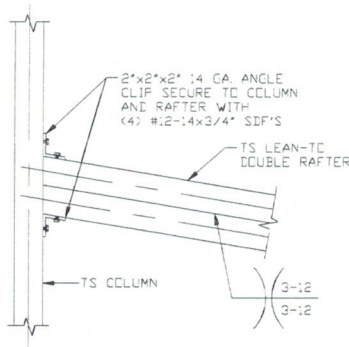

16D

**LEAN-TO RAFTER
 TO RAFTER POST
 CONNECTION DETAIL
 FOR WIDTHS $<$ 16'-0"**

SCALE: NTS

**MOORE AND ASSOCIATES
 ENGINEERING AND CONSULTING, INC.**

DRAWN BY: JG

CHECKED BY: PH

PROJECT MGR: WSM

CLIENT: NC CARPORTS

NC CARPORTS AND GARAGES, LLC
 309 S. DEPOT STREET
 PILOT MOUNTAIN, NC 27041
 30'-0" x 16'-0" ENCLOSED STRUCTURE

DATE: 6-25-19

SHT. 11A

SCALE: NTS

DWG. NO: SK-3

JOB NO:
18315S/19179S

REV: 1

THIS DOCUMENT IS THE PROPERTY OF MOORE AND ASSOCIATES ENGINEERING AND CONSULTING. THE UNAUTHORIZED REPRODUCTION, COPYING, OR OTHERWISE USE OF THIS DOCUMENT IS STRICTLY PROHIBITED AND ANY INFRINGEMENT THEREUPON MAY BE SUBJECT TO LEGAL ACTION.

BOX EAVE RAFTER VERTICAL ROOF/SIDING OPTION

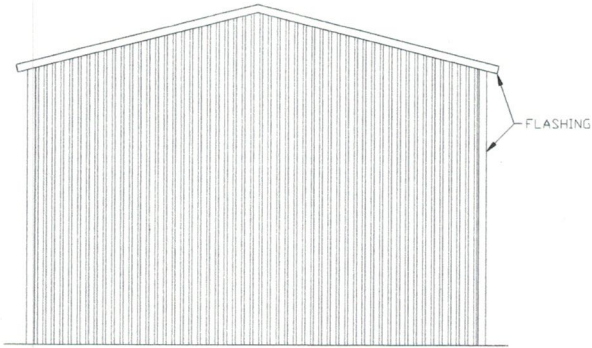

**TYPICAL END ELEVATION
VERTICAL ROOF/SIDING**

SCALE: NTS

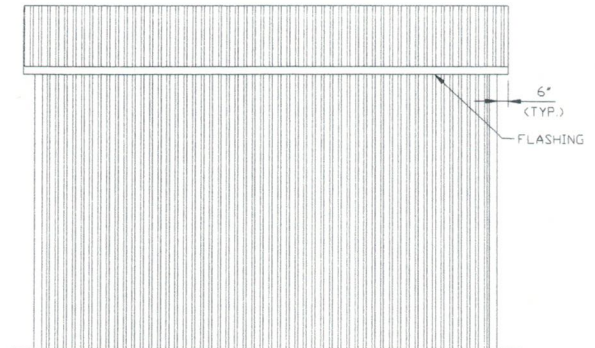

**TYPICAL SIDE ELEVATION
VERTICAL ROOF/SIDING**

SCALE: NTS

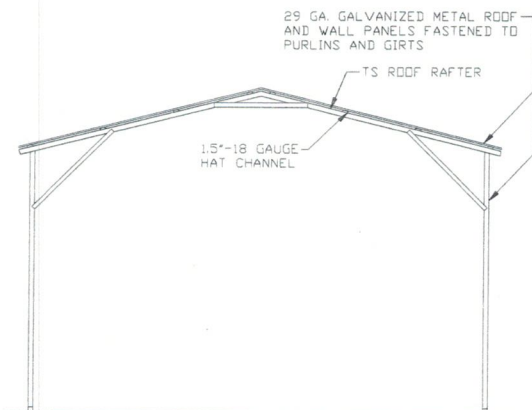

**TYPICAL SECTION
VERTICAL ROOF/SIDING OPTION**

SCALE: NTS

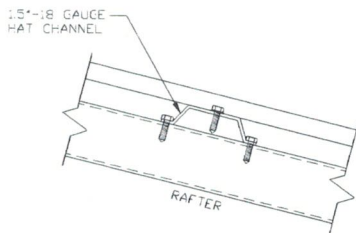

PANEL ATTACHMENT

(ALTERNATE FOR VERTICAL ROOF PANELS)
SCALE: NTS

**MOORE AND ASSOCIATES
ENGINEERING AND CONSULTING, INC.**

DRAWN BY: JG

CHECKED BY: PH

PROJECT MGR: WSM

CLIENT: NC CARPORTS

NC CARPORTS AND GARAGES, LLC
309 S. DEPOT STREET
PILOT MOUNTAIN, NC 27041
30'-0" x 16'-0" ENCLOSED STRUCTURE

DATE: 6-25-19

SHT. 12

SCALE: NTS

DWG. NO: SK-3

JOB NO:

18315S/19179S

REV.: 1

THIS DOCUMENT IS THE PROPERTY OF MOORE AND ASSOCIATES ENGINEERING AND CONSULTING. THE UNAUTHORIZED REPRODUCTION, COPYING, OR OTHERWISE USE OF THIS DOCUMENT IS STRICTLY PROHIBITED AND ANY INFRINGEMENT THEREUPON MAY BE SUBJECT TO LEGAL ACTION.

BOX EAVE RAFTER VERTICAL ROOF/SIDING OPTION

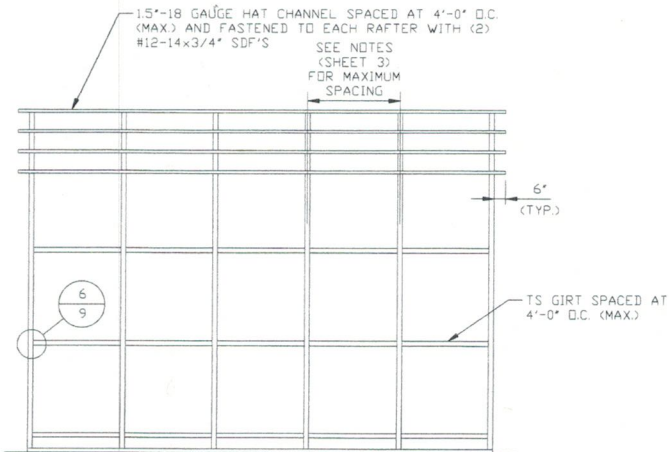

**TYPICAL FRAMING SECTION
VERTICAL ROOF/SIDING OPTION
WITH TS GIRTS**

SCALE: NTS

**MOORE AND ASSOCIATES
ENGINEERING AND CONSULTING, INC.**

DRAWN BY: JG

CHECKED BY: PH

PROJECT MGR: WSM

CLIENT: NC CARPORTS

NC CARPORTS AND GARAGES, LLC
309 S. DEPOT STREET
PILOT MOUNTAIN, NC 27041
30'-0" x 16'-0" ENCLOSED STRUCTURE

DATE: 6-25-19

SCALE: NTS

JOB NO:
18315S/19179S

SHT. 12A

DWG. NO: SK-3

REV: 1

THIS DOCUMENT IS THE PROPERTY OF MOORE AND ASSOCIATES ENGINEERING AND CONSULTING. THE UNAUTHORIZED REPRODUCTION, COPYING, OR OTHERWISE USE OF THIS DOCUMENT IS STRICTLY PROHIBITED AND ANY INFRINGEMENT THEREUPON MAY BE SUBJECT TO LEGAL ACTION.