



STRUCTURAL DESIGN

ENCLOSED BUILDING

**MAXIMUM 30'- 0" WIDE X 20'- 0" HEIGHT-
BOX EAVE FRAME AND BOW FRAME**

**23 October 2020
Revision 0
M&A Project No. 20193S**

Prepared for:

**Vega Metal Structures & Concrete, LLC
4047 US Hwy 311
Randleman, NC 27317**

Prepared by:

Moore and Associates Engineering and Consulting, Inc.

**1009 East Avenue
North Augusta, SC 29841**

**401 S. Main Street, Suite 200
Mount Airy, NC 27030**



		<p>Professional Certification. I hereby certify that these documents were prepared or approved by me, and that I am a duly licensed professional engineer under the laws of the State of Maryland, License No. 49744, Expiration Date <u>6/6/2022</u></p>	

<p>MOORE AND ASSOCIATES ENGINEERING AND CONSULTING, INC.</p>	<p>DRAWN BY: JG</p>	<p>VEGA METAL STRUCTURES & CONCRETE, LLC. 4047 US HWY 311 RANDLEMAN, NC 27317 30'-0"x20'-0" ENCLOSED STRUCTURE</p>		
	<p>CHECKED BY: PDH</p>	<p>PROJECT MGR: VSM</p>	<p>DATE: 10-23-20</p>	<p>SCALE: NTS</p>
<p><small>THIS DOCUMENT IS THE PROPERTY OF MOORE AND ASSOCIATES ENGINEERING AND CONSULTING. THE UNAUTHORIZED REPRODUCTION, COPYING, OR OTHERWISE USE OF THIS DOCUMENT IS STRICTLY PROHIBITED AND ANY INFRINGEMENT THEREUPON MAY BE SUBJECT TO LEGAL ACTION.</small></p>	<p>CLIENT: VEGA METAL</p>	<p>SHT. 1</p>	<p>DWG. NO: SK-3</p>	<p>REV: 0</p>

DRAWING INDEX

SHEET 1	PE SEAL COVER SHEET
SHEET 2	DRAWING INDEX
SHEET 3	INSTALLATION NOTES AND SPECIFICATIONS
SHEET 4	TYPICAL SIDE AND END ELEVATIONS
SHEET 5	TYPICAL RAFTER/COLUMN END FRAMING SECTION (BOX EAVE RAFTER)
SHEET 5A	TYPICAL RAFTER/COLUMN END AND SIDE FRAMING SECTION (BOX EAVE RAFTER)
SHEET 6	COLUMN CONNECTION DETAILS (BOX EAVE RAFTER STRUCTURE)
SHEET 6A	COLUMN CONNECTION DETAILS (BOX EAVE RAFTER STRUCTURE)
SHEET 7	TYPICAL RAFTER/COLUMN END FRAMING SECTION (BOW EAVE RAFTER)
SHEET 7A	TYPICAL RAFTER/COLUMN END AND SIDE FRAMING SECTION (BOW EAVE RAFTER)
SHEET 8	COLUMN CONNECTION DETAILS (BOW EAVE RAFTER STRUCTURE)
SHEET 8A	COLUMN CONNECTION DETAILS (BOW EAVE RAFTER STRUCTURE)
SHEET 9	BASE RAIL ANCHORAGE OPTIONS
SHEET 9A	ADDITIONAL BASE RAIL ANCHOR OPTION
SHEET 10	BOX EAVE RAFTER END WALL AND SIDE WALL OPENINGS
SHEET 11	BOW EAVE RAFTER END WALL AND SIDE WALL OPENINGS
SHEET 12	CONNECTION DETAILS
SHEET 13	CONNECTION DETAILS
SHEET 14	BOX EAVE RAFTER LEAN-TO OPTION
SHEET 14A	BOX EAVE LEAN-TO OPTIONS FOR RAFTER SPANS $\leq 10'-0"$
SHEET 14B	BOX EAVE LEAN-TO OPTIONS FOR RAFTER SPANS $\leq 10'-0"$
SHEET 14C	BOX EAVE LEAN-TO OPTIONS FOR RAFTER SPANS $10'-0" < TO \leq 16'-0"$
SHEET 14D	BOX EAVE LEAN-TO OPTIONS FOR RAFTER SPANS $10'-0" < TO \leq 16'-0"$
SHEET 14E	BOX EAVE LEAN-TO OPTIONS FOR RAFTER SPANS $16'-0" < TO \leq 20'-0"$
SHEET 14F	BOX EAVE LEAN-TO OPTIONS FOR RAFTER SPANS $16'-0" < TO \leq 20'-0"$
SHEET 15	BOW EAVE RAFTER LEAN-TO OPTION
SHEET 15A	BOW EAVE LEAN-TO OPTIONS FOR RAFTER SPANS $\leq 10'-0"$
SHEET 15B	BOX EAVE LEAN-TO OPTIONS FOR RAFTER SPANS $\leq 10'-0"$
SHEET 15C	BOW EAVE LEAN-TO OPTIONS FOR RAFTER SPANS $10'-0" < TO \leq 16'-0"$
SHEET 15D	BOX EAVE LEAN-TO OPTIONS FOR RAFTER SPANS $10'-0" < TO \leq 16'-0"$
SHEET 15E	BOW EAVE LEAN-TO OPTIONS FOR RAFTER SPANS $16'-0" < TO \leq 20'-0"$
SHEET 15F	BOX EAVE LEAN-TO OPTIONS FOR RAFTER SPANS $16'-0" < TO \leq 20'-0"$
SHEET 16	BOX EAVE RAFTER VERTICAL ROOF/SIDING OPTION
SHEET 17	SIDE WALL AND END WALL HEADER OPTIONS

MOORE AND ASSOCIATES ENGINEERING AND CONSULTING, INC.	DRAWN BY: JG	VEGA METAL STRUCTURES & CONCRETE, LLC. 4047 US HWY 311 RANDLEMAN, NC 27317 30'-0"x20'-0" ENCLOSED STRUCTURE		
	CHECKED BY: PDH			
THIS DOCUMENT IS THE PROPERTY OF MOORE AND ASSOCIATES ENGINEERING AND CONSULTING. THE UNAUTHORIZED REPRODUCTION, COPYING, OR OTHERWISE USE OF THIS DOCUMENT IS STRICTLY PROHIBITED AND ANY INFRINGEMENT THEREUPON MAY BE SUBJECT TO LEGAL ACTION.	PROJECT MGR: WSM	DATE: 10-23-20	SCALE: NTS	JOB NO: 20193S
	CLIENT: VEGA METAL	SHT. 2	DWG. NO: SK-3	REV. 0

INSTALLATION NOTES AND SPECIFICATIONS

1. DESIGN IS FOR MAXIMUM 30'-0" WIDE x 20'-0" EAVE HEIGHT ENCLOSED STRUCTURES
2. DESIGN WAS DONE IN ACCORDANCE WITH THE 2020 FLORIDA BUILDING CODE, 7TH EDITION, 2018 NORTH CAROLINA BUILDING CODE (NCBC), 2018 INTERNATIONAL BUILDING CODE (IBC), 2015 IBC AND 2012 IBC.
3. DESIGN LOADS ARE AS FOLLOWS:
 - A) DEAD LOAD = 15 PSF
 - B) LIVE LOAD = 12 PSF
 - C) GROUND SNOW LOAD = 45 PSF
 - = 30 PSF WITH U-CHANNEL PEAK BRACE (W ≤ 24'-0")

NOTE: DIFFERENTIAL LOADING DUE TO SNOW DRIFTING NOT ANALYZED.
4. 3-SECOND GUST ULTIMATE WIND SPEED (V_{ULT}) = ≤ 145 MPH (NOMINAL WIND SPEED = ≤ 112 MPH)
5. MAXIMUM RAFTER/POST AND END POST SPACING = 50 FEET (UNLESS NOTED OTHERWISE)
6. END WALL COLUMNS (POSTS) ARE EQUIVALENT TO SIDE WALL POSTS IN SIZE AND SPACING (UNLESS NOTED OTHERWISE).
7. RISK CATEGORY I.
8. WIND EXPOSURE CATEGORY B.
9. SPECIFICATIONS APPLICABLE TO 29 GAUGE METAL PANELS FASTENED DIRECTLY TO 2 1/2" x 2 1/2" - 14 GAUGE TUBE STEEL (TS) FRAMING MEMBERS (UNLESS NOTED OTHERWISE). WHERE TS 2 1/2" x 2 1/2" - 14 GAUGE IS SPECIFIED, TS 2 1/4" x 2 1/4" - 12 GAUGE MAY BE USED AS AN OPTION.
10. AVERAGE FASTENER SPACING ON-CENTERS ALONG RAFTERS OR HAT CHANNELS, AND COLUMNS (INTERIOR OR END) = 10" O.C. (MAX)
11. FASTENERS CONSIST OF #12-14x3/4" SELF-DRILLING FASTENER (SDF), USE CONTROL SEAL WASHER WITH EXTERIOR FASTENERS. SPECIFICATIONS APPLICABLE ONLY FOR MEAN ROOF HEIGHT OF 20 FEET OR LESS, AND ROOF SLOPES OF 14" (3:12 PITCH) OR LESS. SPACING REQUIREMENTS FOR OTHER ROOF HEIGHTS AND/OR SLOPES MAY VARY. ROOF SLOPES LESS THAN 3:12 REQUIRE USE OF LAP JOINT SEALANT.
12. ANCHORS SHALL BE INSTALLED THROUGH BASE RAIL WITHIN 6" OF EACH RAFTER COLUMN ALONG SIDES.
13. STANDARD GROUND ANCHORS (SOIL NAILS) CONSIST OF #4 REBAR W/ WELDED NUT x MINIMUM 36" LONG AND MAY ONLY BE USED IN SUITABLE SOILS. OPTIONAL ANCHORAGE MAY BE USED IN SUITABLE SOILS AND MUST BE USED IN UNSUITABLE SOILS AS NOTED. COORDINATE WITH LOCAL CODES/ORDINANCES REGARDING MINIMUM LENGTH FOR FROST DEPTH PROTECTION.
14. WIND FORCES GOVERN OVER SEISMIC FORCES. SEISMIC PARAMETERS ANALYZED ARE:
 - SOIL SITE CLASS = D
 - RISK CATEGORY I
 - R= 3.25 $I_E = 1.0$
 - $S_{DS} = 2.039 g$ $V = C_s W$
 - $S_{01} = 1.258 g$
15. DOOR AND WINDOW PRESSURE VALUES ARE APPLICABLE FOR THE STATE OF FLORIDA

MOORE AND ASSOCIATES ENGINEERING AND CONSULTING, INC.	DRAWN BY: JG	VEGA METAL STRUCTURES & CONCRETE, LLC. 4047 US HWY 311 RANDLEMAN, NC 27317 30'-0" x 20'-0" ENCLOSED STRUCTURE		
	CHECKED BY: PDH			
THIS DOCUMENT IS THE PROPERTY OF MOORE AND ASSOCIATES ENGINEERING AND CONSULTING. THE UNAUTHORIZED REPRODUCTION, COPYING, OR OTHERWISE USE OF THIS DOCUMENT IS STRICTLY PROHIBITED AND ANY INFRINGEMENT THEREUPON MAY BE SUBJECT TO LEGAL ACTION.	PROJECT MGR: VSM	DATE: 10-23-20	SCALE: NTS	JOB NO: 20193S
	CLIENT: VEGA METAL	SHT. 3	DWG. NO SK-3	REV: 0

BOX EAVE FRAME RAFTER STRUCTURE

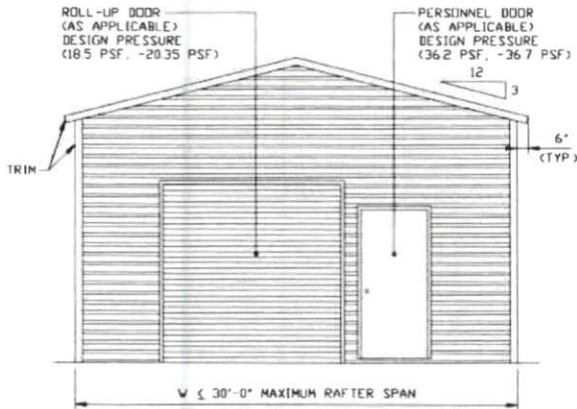

TYPICAL END ELEVATION
SCALE: NTS

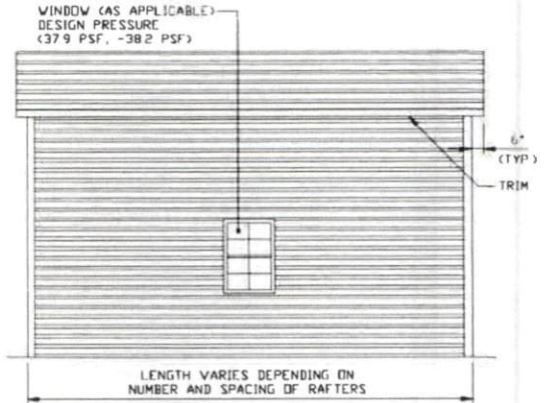

TYPICAL SIDE ELEVATION
SCALE: NTS

BOW FRAME RAFTER STRUCTURE

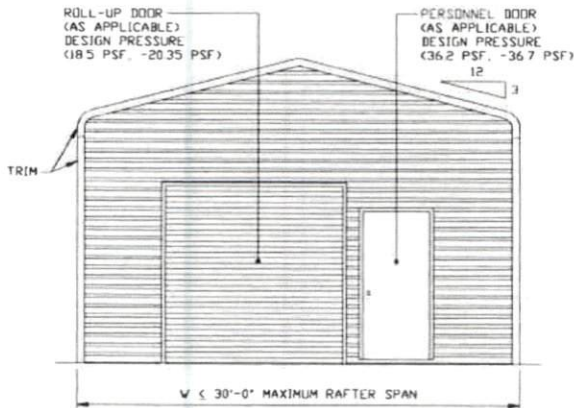

TYPICAL END ELEVATION
SCALE: NTS

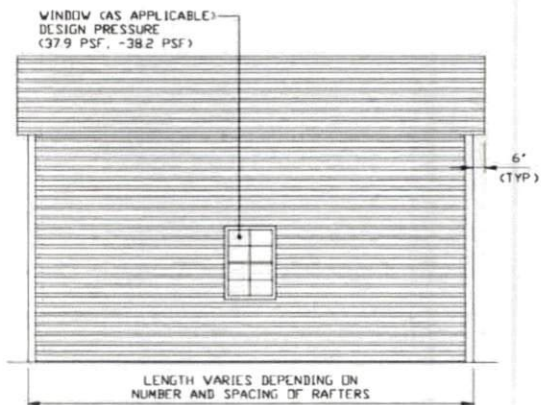

TYPICAL SIDE ELEVATION
SCALE: NTS

MOORE AND ASSOCIATES
ENGINEERING AND CONSULTING, INC.

DRAWN BY: JG
CHECKED BY: PDH

VEGA METAL STRUCTURES & CONCRETE, LLC.
4047 US HWY 311
RANDLEMAN, NC 27317
30'-0"x20'-0" ENCLOSED STRUCTURE

THIS DOCUMENT IS THE PROPERTY OF MOORE AND ASSOCIATES ENGINEERING AND CONSULTING. THE UNAUTHORIZED REPRODUCTION, COPYING, OR OTHERWISE USE OF THIS DOCUMENT IS STRICTLY PROHIBITED AND ANY INFRINGEMENT THEREUPON MAY BE SUBJECT TO LEGAL ACTION.

PROJECT MGR: WSM
CLIENT: VEGA METAL

DATE: 10-23-20
SHT. 4

SCALE: NTS
DWG. NO: SK-3

JOB NO: 20193S
REV: 0

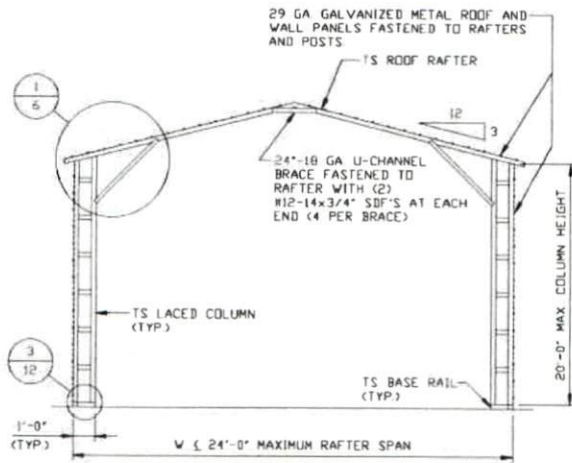

TYPICAL RAFTER/COLUMN END FRAME SECTION
SCALE: NTS

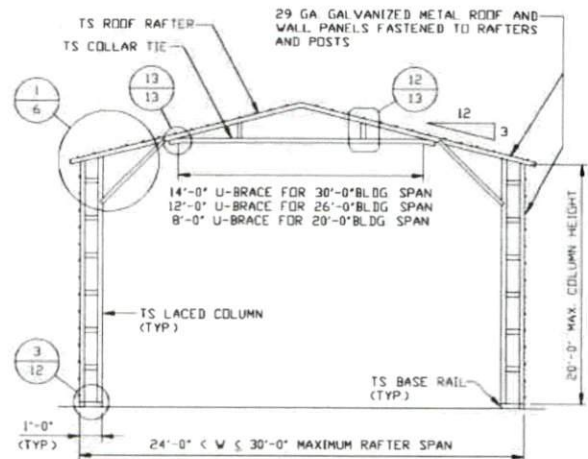

TYPICAL RAFTER/COLUMN END FRAME SECTION
SCALE: NTS

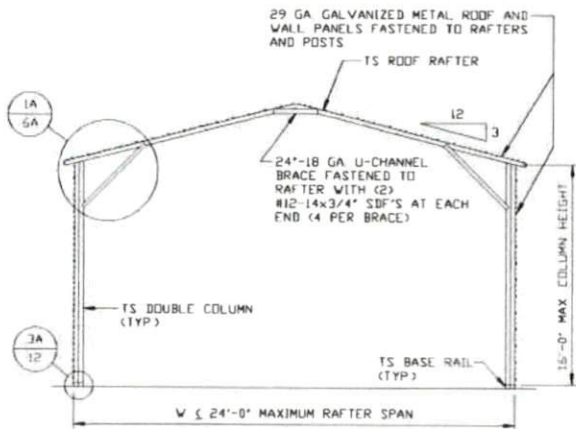

TYPICAL RAFTER/COLUMN END FRAME SECTION
SCALE: NTS

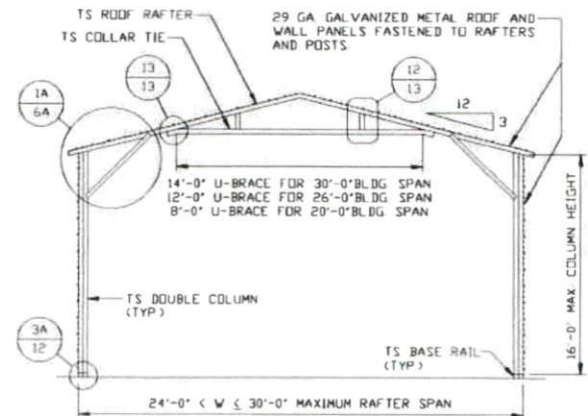

TYPICAL RAFTER/COLUMN END FRAME SECTION
SCALE: NTS

MOORE AND ASSOCIATES
ENGINEERING AND CONSULTING, INC.

DRAWN BY: JG

CHECKED BY: PDH

PROJECT MGR: WSM

CLIENT: VEGA METAL

VEGA METAL STRUCTURES & CONCRETE, LLC.
4047 US HWY 311
RANDLEMAN, NC 27317
30'-0"x20'-0" ENCLOSED STRUCTURE

DATE: 10-23-20

SCALE: NTS

JOB NO: 201935

SHT. 5

DWG. NO: SK-3

REV: 0

THIS DOCUMENT IS THE PROPERTY OF MOORE AND ASSOCIATES ENGINEERING AND CONSULTING. THE UNAUTHORIZED REPRODUCTION, COPYING, OR OTHERWISE USE OF THIS DOCUMENT IS STRICTLY PROHIBITED AND ANY INFRINGEMENT THEREUPON MAY BE SUBJECT TO LEGAL ACTION.

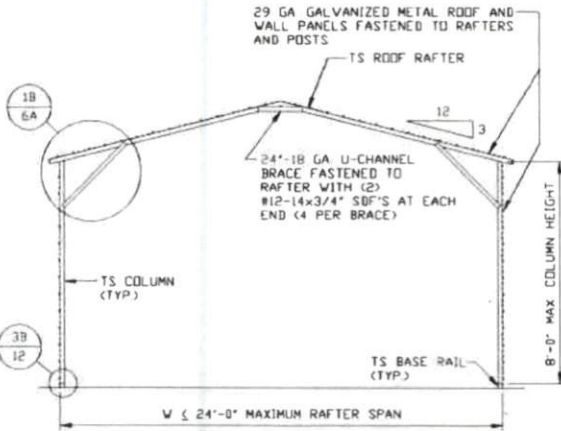

TYPICAL RAFTER/COLUMN END FRAME SECTION
SCALE: NTS

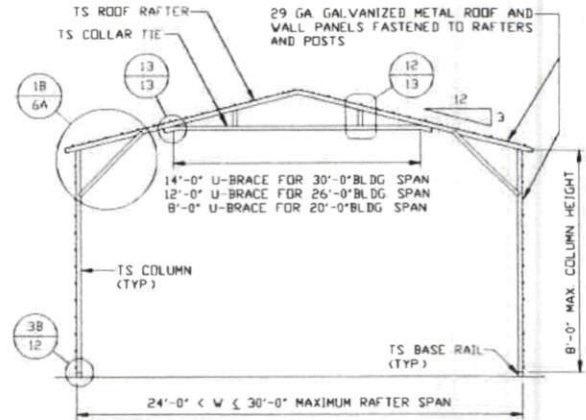

TYPICAL RAFTER/COLUMN END FRAME SECTION
SCALE: NTS

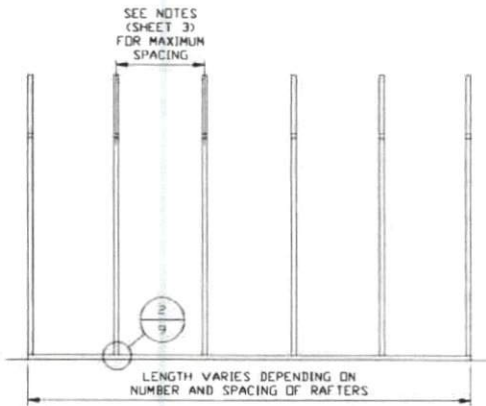

TYPICAL RAFTER/COLUMN SIDE FRAMING SECTION
SCALE: NTS

**MOORE AND ASSOCIATES
ENGINEERING AND CONSULTING, INC.**

DRAWN BY: JG
CHECKED BY: PDH

VEGA METAL STRUCTURES & CONCRETE, LLC.
4047 US HWY 311
RANDLEMAN, NC 27317
30'-0"x20'-0" ENCLOSED STRUCTURE

THIS DOCUMENT IS THE PROPERTY OF MOORE AND ASSOCIATES ENGINEERING AND CONSULTING. THE UNAUTHORIZED REPRODUCTION, COPYING, OR OTHERWISE USE OF THIS DOCUMENT IS STRICTLY PROHIBITED AND ANY INFRINGEMENT THEREUPON MAY BE SUBJECT TO LEGAL ACTION.

PROJECT MGR: WSM	DATE: 10-23-20	SCALE: NTS	JOB NO: P0193S
CLIENT: VEGA METAL	SHT. 5A	DWG. NO SK-3	REV: 0

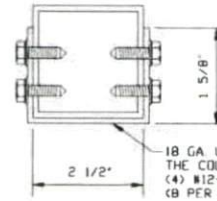
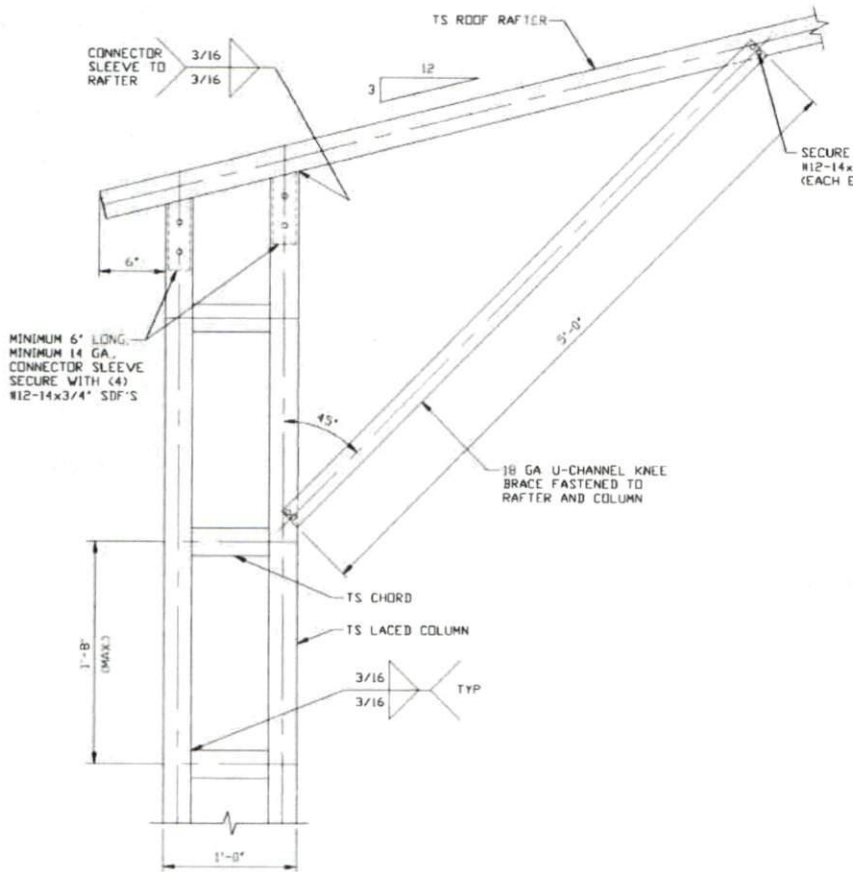

BRACE SECTION
SCALE: NTS

1 BOX EAVE RAFTER COLUMN CONNECTION
DETAIL FOR HEIGHTS 16'-0" < TO ≤ 20'-0"
SCALE: NTS

MOORE AND ASSOCIATES ENGINEERING AND CONSULTING, INC.	DRAWN BY: JG	VEGA METAL STRUCTURES & CONCRETE, LLC. 4047 US HWY 311 RANDLEMAN, NC 27317 30'-0" x 20'-0" ENCLOSED STRUCTURE		
	CHECKED BY: PDH			
THIS DOCUMENT IS THE PROPERTY OF MOORE AND ASSOCIATES ENGINEERING AND CONSULTING. THE UNAUTHORIZED REPRODUCTION, COPYING, OR OTHERWISE USE OF THIS DOCUMENT IS STRICTLY PROHIBITED AND ANY INFRINGEMENT THEREUPON MAY BE SUBJECT TO LEGAL ACTION.	PROJECT MGR: VSM	DATE: 10-23-20	SCALE: NTS	JOB NO: 20193S
	CLIENT: VEGA METAL	SHT. 6	DWG. NO SK-3	REV: 0

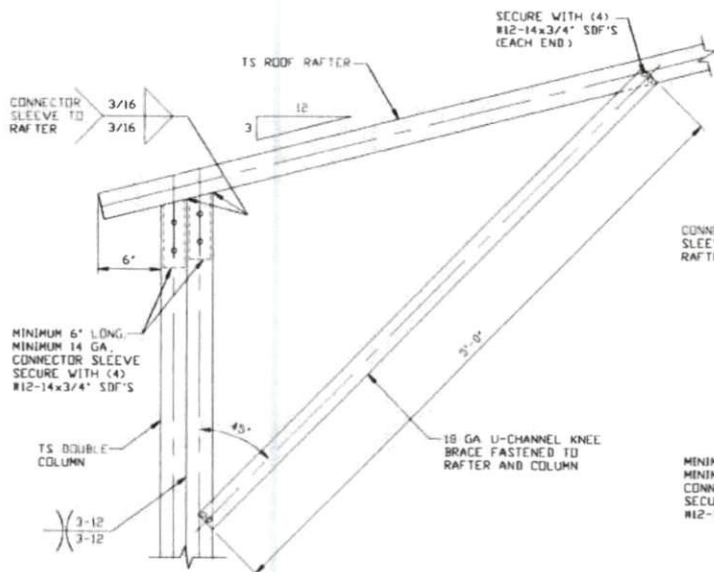

1A

BOX EAVE RAFTER COLUMN CONNECTION DETAIL FOR HEIGHTS 8'-0" < TO <= 16'-0"

SCALE: NTS
NOTE: 4'-0" KNEE BRACE MAY BE USED FOR BUILDING WIDTHS <= 26'-0"

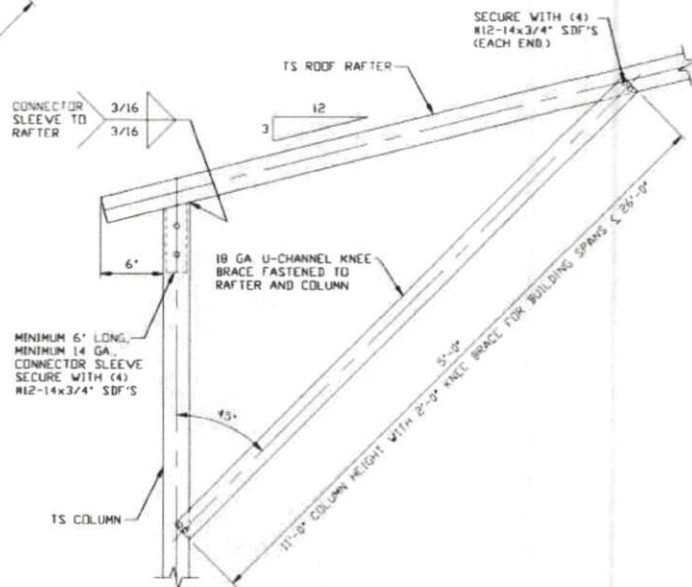

1B

BOX EAVE RAFTER COLUMN CONNECTION DETAIL FOR HEIGHTS <= 8'-0"

SCALE: NTS
NOTE: 2'-0" KNEE BRACE MAY BE USED FOR BUILDING WIDTHS <= 26'-0"

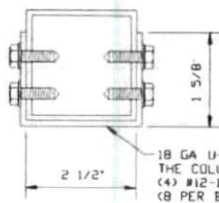

BRACE SECTION

SCALE: NTS

**MOORE AND ASSOCIATES
ENGINEERING AND CONSULTING, INC.**

DRAWN BY: JG

CHECKED BY: PDH

PROJECT MGR: WSM

CLIENT: VEGA METAL

VEGA METAL STRUCTURES & CONCRETE, LLC
4047 US HWY 311
RANDLEMAN, NC 27317
30'-0"x20'-0" ENCLOSED STRUCTURE

DATE: 10-23-20

SCALE: NTS

JOB NO: 20193S

SHT. 6A

DWG. NO SK-3

REV: 0

THIS DOCUMENT IS THE PROPERTY OF MOORE AND ASSOCIATES ENGINEERING AND CONSULTING. THE UNAUTHORIZED REPRODUCTION, COPYING, OR OTHERWISE USE OF THIS DOCUMENT IS STRICTLY PROHIBITED AND ANY INFRINGEMENT THEREUPON MAY BE SUBJECT TO LEGAL ACTION.

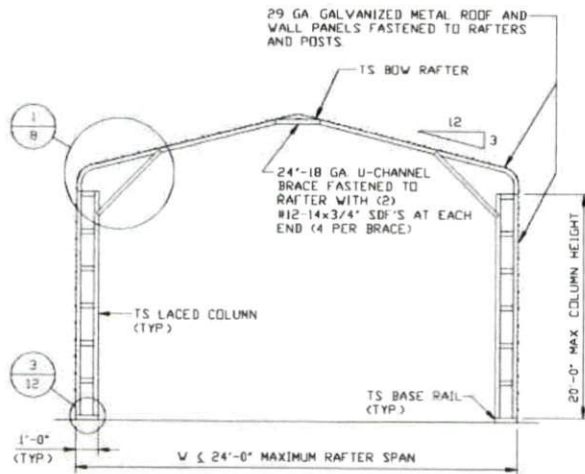

TYPICAL RAFTER/COLUMN END FRAME SECTION
SCALE: NTS

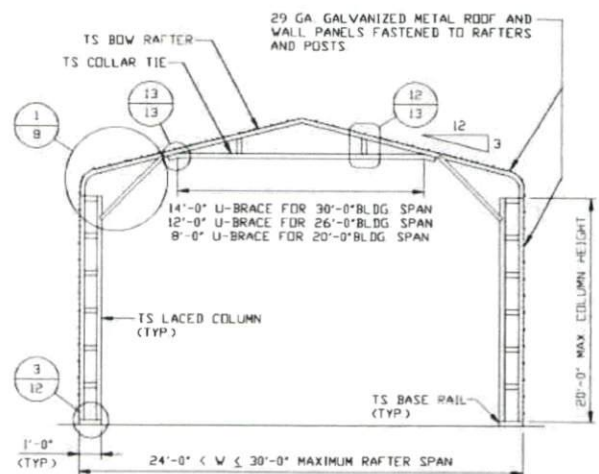

TYPICAL RAFTER/COLUMN END FRAME SECTION
SCALE: NTS

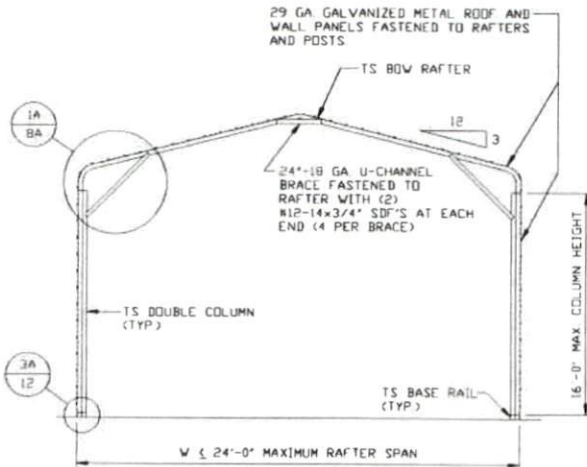

TYPICAL RAFTER/COLUMN END FRAME SECTION
SCALE: NTS

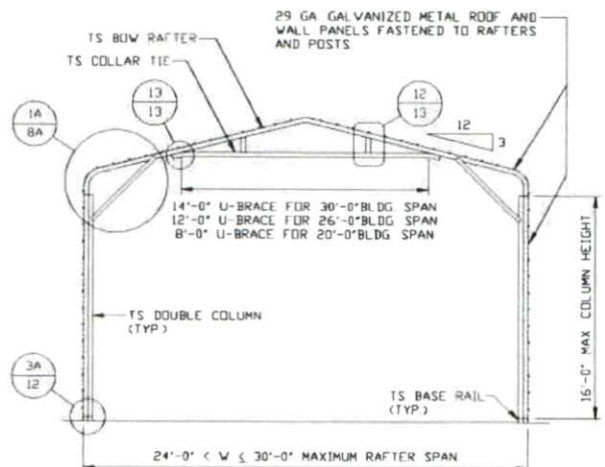

TYPICAL RAFTER/COLUMN END FRAME SECTION
SCALE: NTS

MOORE AND ASSOCIATES
ENGINEERING AND CONSULTING, INC.

DRAWN BY: JG

CHECKED BY: PDH

PROJECT MGR: WSM

CLIENT: VEGA METAL

VEGA METAL STRUCTURES & CONCRETE, LLC.
4047 US HWY 311
RANDLEMAN, NC 27317
30'-0"x20'-0" ENCLOSED STRUCTURE

DATE: 10-23-20

SHT. 7

SCALE: NTS

DWG. NO: SK-3

JOB NO: 20193S

REV: 0

THIS DOCUMENT IS THE PROPERTY OF MOORE AND ASSOCIATES ENGINEERING AND CONSULTING. THE UNAUTHORIZED REPRODUCTION, COPYING, OR OTHERWISE USE OF THIS DOCUMENT IS STRICTLY PROHIBITED AND ANY INFRINGEMENT THEREUPON MAY BE SUBJECT TO LEGAL ACTION.

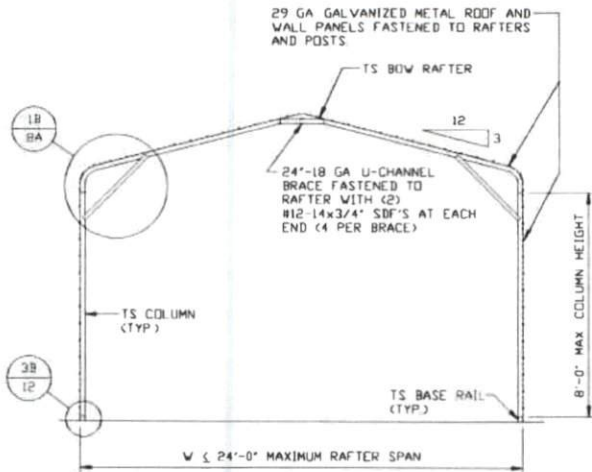

TYPICAL RAFTER/COLUMN END FRAME SECTION

SCALE: NTS

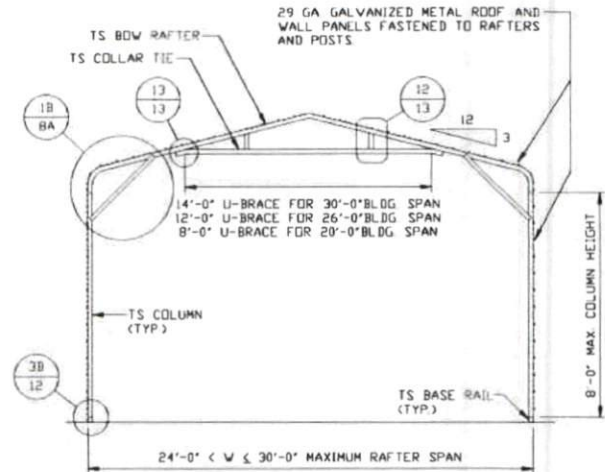

TYPICAL RAFTER/COLUMN END FRAME SECTION

SCALE: NTS

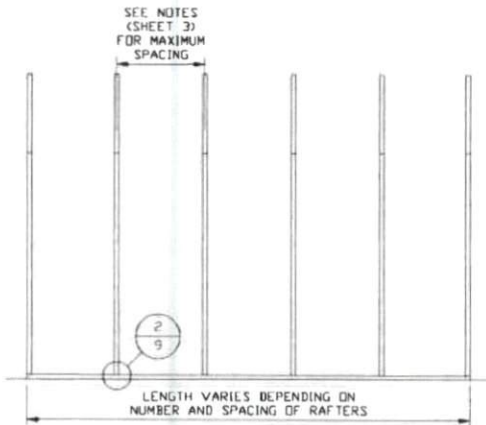

TYPICAL RAFTER/COLUMN FRAMING SIDE SECTION

SCALE: NTS

**MOORE AND ASSOCIATES
ENGINEERING AND CONSULTING, INC.**

DRAWN BY: JG

CHECKED BY: PDH

PROJECT MGR: WSM

CLIENT: VEGA METAL

VEGA METAL STRUCTURES & CONCRETE, LLC.
4047 US HWY 311
RANDLEMAN, NC 27317
30'-0"x20'-0" ENCLOSED STRUCTURE

DATE: 10-23-20

SHT. 7A

SCALE: NTS

DWG. NO SK-3

JOB NO: 20193S

REV: 0

THIS DOCUMENT IS THE PROPERTY OF MOORE AND ASSOCIATES ENGINEERING AND CONSULTING. THE UNAUTHORIZED REPRODUCTION, COPYING, OR OTHERWISE USE OF THIS DOCUMENT IS STRICTLY PROHIBITED AND ANY INFRINGEMENT THEREUPON MAY BE SUBJECT TO LEGAL ACTION.

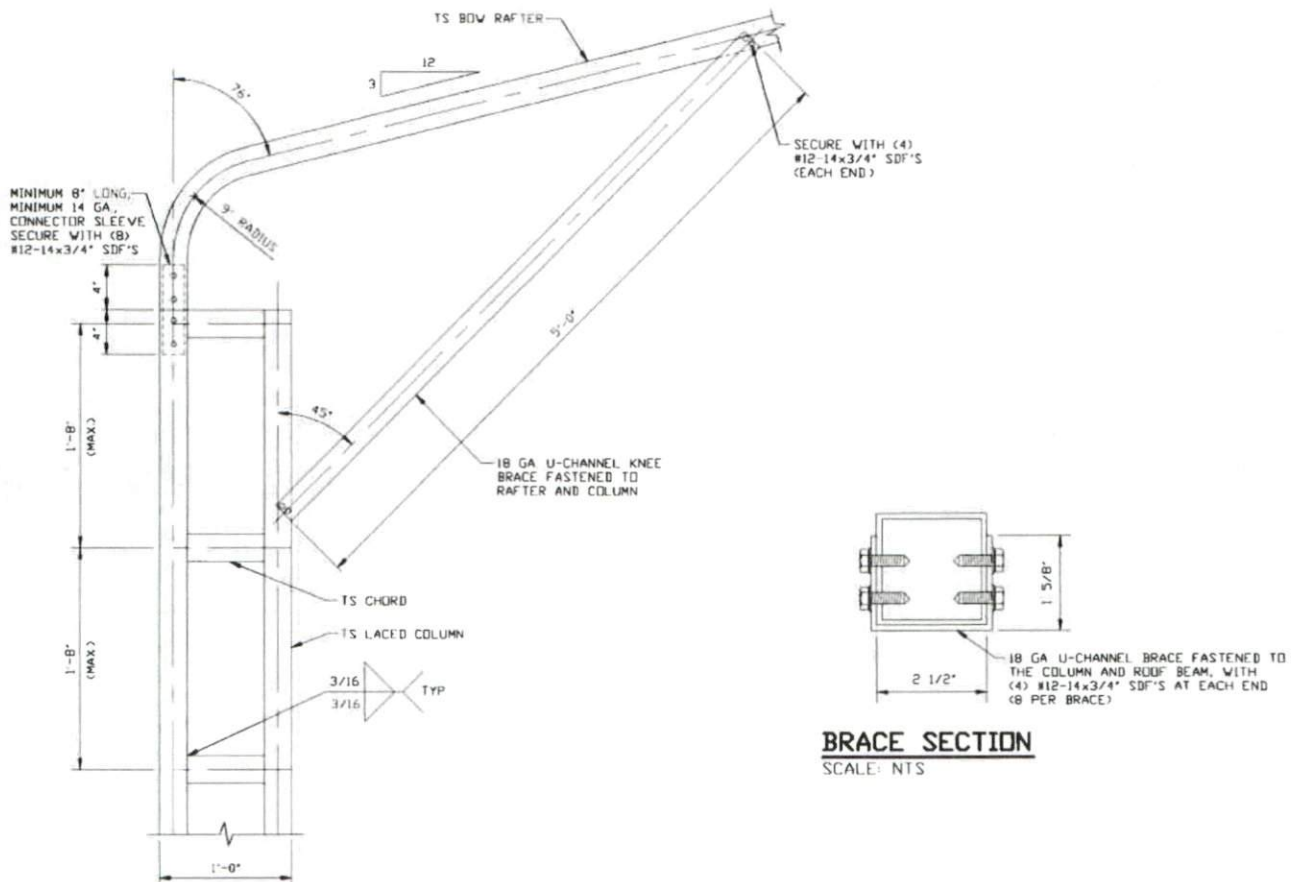

BRACE SECTION
SCALE: NTS

1 BOW EAVE RAFTER COLUMN CONNECTION
DETAIL FOR HEIGHTS 16'-0" < TO ≤ 20'-0"
SCALE: NTS

**MOORE AND ASSOCIATES
ENGINEERING AND CONSULTING, INC.**

DRAWN BY: JG
CHECKED BY: PDH

VEGA METAL STRUCTURES & CONCRETE, LLC.
4047 US HWY 311
RANDLEMAN, NC 27317
30'-0" x 20'-0" ENCLOSED STRUCTURE

THIS DOCUMENT IS THE PROPERTY OF MOORE AND ASSOCIATES ENGINEERING AND CONSULTING. THE UNAUTHORIZED REPRODUCTION, COPYING, OR OTHERWISE USE OF THIS DOCUMENT IS STRICTLY PROHIBITED AND ANY INFRINGEMENT THEREUPON MAY BE SUBJECT TO LEGAL ACTION.

PROJECT MGR: WSM	DATE: 10-23-20	SCALE: NTS	JOB NO: 20193S
CLIENT: VEGA METAL	SHT. 8	DWG. NO: SK-3	REV: 0

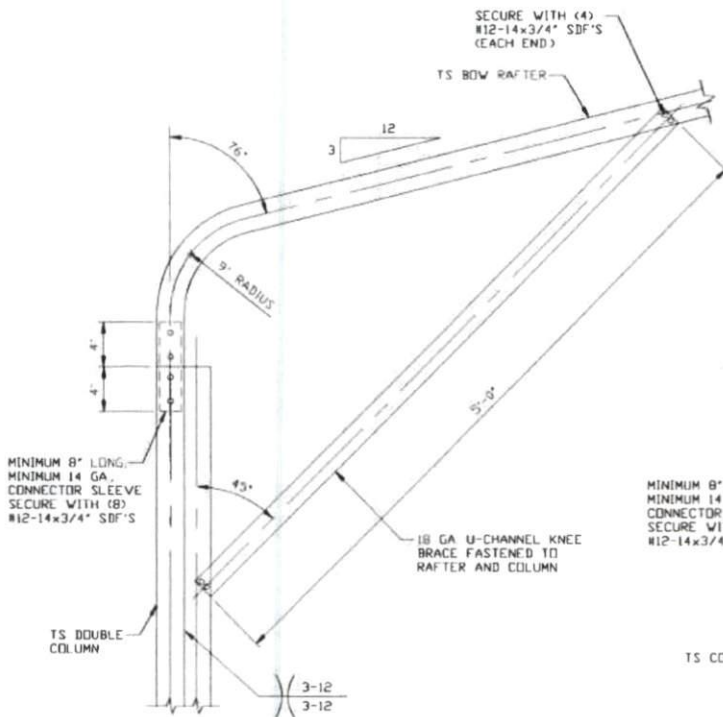

BOW EAVE RAFTER COLUMN CONNECTION DETAIL FOR HEIGHTS 8'-0" < TO ≤ 16'-0"

1A

SCALE: NTS

NOTE: 4'-0" KNEE BRACE MAY BE USED FOR BUILDING WIDTHS ≤ 26'-0"

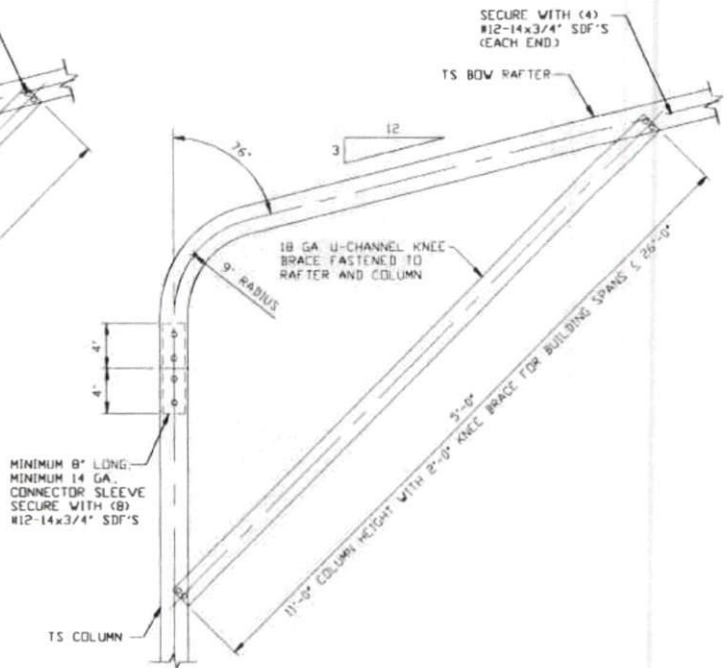

BOW EAVE RAFTER COLUMN CONNECTION DETAIL FOR HEIGHTS ≤ 8'-0"

1B

SCALE: NTS

NOTE: 2'-0" KNEE BRACE MAY BE USED FOR BUILDING WIDTHS ≤ 26'-0"

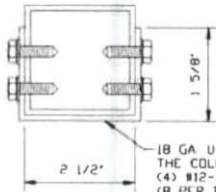

BRACE SECTION

SCALE: NTS

MOORE AND ASSOCIATES
ENGINEERING AND CONSULTING, INC.

DRAWN BY: JG

CHECKED BY: PDH

PROJECT MGR: WSH

CLIENT: VEGA METAL

VEGA METAL STRUCTURES & CONCRETE, LLC.
4047 US HWY 311
RANDLEMAN, NC 27317
30'-0" x 20'-0" ENCLOSED STRUCTURE

DATE: 10-23-20

SHT. 8A

SCALE: NTS

DWG. NO: SK-3

JOB NO: 20193S

REV: 0

THIS DOCUMENT IS THE PROPERTY OF MOORE AND ASSOCIATES ENGINEERING AND CONSULTING. THE UNAUTHORIZED REPRODUCTION, COPYING, OR OTHERWISE USE OF THIS DOCUMENT IS STRICTLY PROHIBITED AND ANY INFRACTION THEREUPON MAY BE SUBJECT TO LEGAL ACTION.

BASE RAIL ANCHORAGE OPTIONS

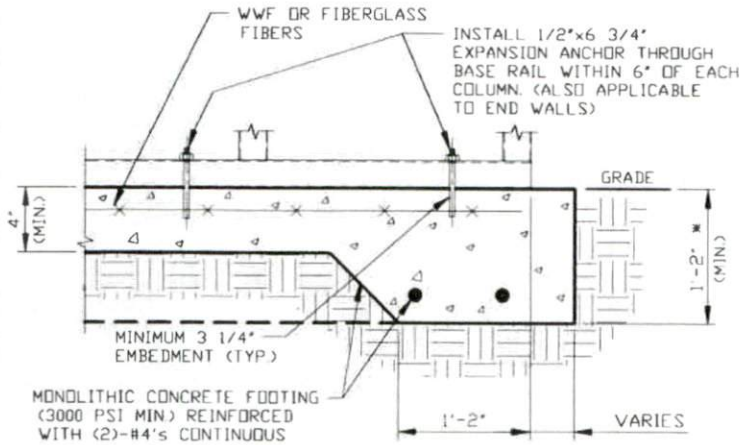

2

CONCRETE MONOLITHIC SLAB BASE RAIL ANCHORAGE

SCALE: NTS
MINIMUM ANCHOR EDGE DISTANCE IS 4"
* COORDINATE WITH LOCAL BUILDING CODE
AND/OR BUILDING OFFICIAL REGARDING
REQUIRED FOOTING DEPTH.

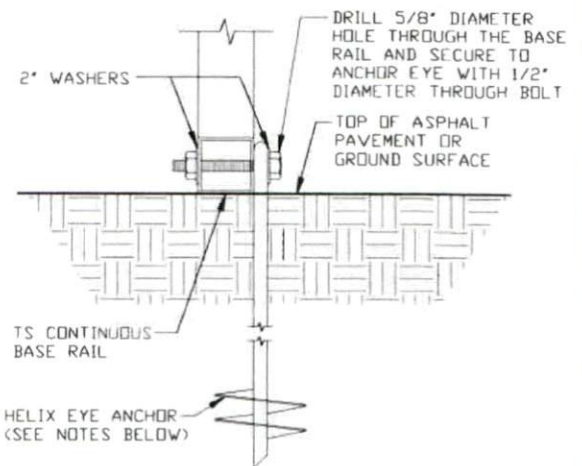

2A

GROUND BASE HELIX ANCHORAGE

SCALE: NTS (CAN BE USED FOR ASPHALT)
* COORDINATE WITH LOCAL CODES/ORD.
REGARDING MIN. FROST DEPTH (LENGTH).

GENERAL NOTES

NOTE: CONCRETE MONOLITHIC SLAB DESIGN BASED ON MINIMUM SOIL BEARING CAPACITY OF 1,500 PSF.

CONCRETE:

CONCRETE SHALL HAVE A MINIMUM SPECIFIED COMPRESSIVE STRENGTH OF 3,000 PSI AT 28 DAYS.

COVER OVER REINFORCING STEEL:

FOR FOUNDATIONS, MINIMUM CONCRETE COVER OVER REINFORCING BARS SHALL BE PER ACI-318:

3" IN FOUNDATIONS WHERE THE CONCRETE IS CAST AGAINST AND PERMANENTLY IN CONTACT WITH THE EARTH OR EXPOSED TO THE EARTH OR WEATHER, AND 1 1/2" ELSEWHERE.

REINFORCING STEEL:

THE TURNDOWN REINFORCING STEEL SHALL BE ASTM A615 GRADE 60. THE SLAB REINFORCEMENT SHALL BE WELDED WIRE FABRIC MEETING ASTM A185 OR FIBERGLASS FIBER REINFORCEMENT.

REINFORCEMENT MAY BE BENT IN THE SHOP OR THE FIELD PROVIDED:

1. REINFORCEMENT IS BENT COLD.
2. THE DIAMETER OF THE BEND, MEASURED ON THE INSIDE OF THE BAR, IS NOT LESS THAN SIX-BAR DIAMETERS.
3. REINFORCEMENT PARTIALLY EMBEDDED IN CONCRETE SHALL NOT BE FIELD BENT.

HELIX ANCHOR NOTES:

1. FOR VERY DENSE AND/OR CEMENTED SANDS, COARSE GRAVEL AND COBBLES, CALICHE, PRELOADED SILTS AND CLAYS, USE MINIMUM (2) 4" HELICES WITH MINIMUM 30" EMBEDMENT OR SINGLE 6" HELIX WITH MINIMUM 50" EMBEDMENT.
2. FOR CORAL USE MINIMUM (2) 4" HELICES WITH MINIMUM 30" EMBEDMENT OR SINGLE 6" HELIX WITH MINIMUM 50" EMBEDMENT.
3. FOR MEDIUM DENSE COARSE SANDS, SANDY GRAVELS, VERY STIFF SILTS, AND CLAYS USE MINIMUM (2) 4" HELICES WITH MINIMUM 30 INCH EMBEDMENT OR SINGLE 6" HELIX WITH MINIMUM 50" EMBEDMENT.
4. FOR LOOSE TO MEDIUM DENSE SANDS, FIRM TO STIFF CLAYS AND SILTS ALLUVIAL FILL, USE MINIMUM (2) 6" HELICES WITH MINIMUM 50" EMBEDMENT.
5. FOR VERY LOOSE TO MEDIUM DENSE SANDS, FIRM TO STIFFER CLAYS AND SILTS, ALLUVIAL FILL, USE MINIMUM (2) 8" HELICES WITH MINIMUM 60" EMBEDMENT.

**MOORE AND ASSOCIATES
ENGINEERING AND CONSULTING, INC.**

DRAWN BY: JG

CHECKED BY: PDH

PROJECT MGR: WSM

CLIENT: VEGA METAL

VEGA METAL STRUCTURES & CONCRETE, LLC.
4047 US HWY 311
RANDLEMAN, NC 27317
30'-0" x 20'-0" ENCLOSED STRUCTURE

DATE: 10-23-20

SHT. 9

SCALE: NTS

DWG. NO: SK-3

JOB NO: 20193S

REV: 0

THIS DOCUMENT IS THE PROPERTY OF MOORE AND ASSOCIATES ENGINEERING AND CONSULTING. THE UNAUTHORIZED REPRODUCTION, COPYING, OR OTHERWISE USE OF THIS DOCUMENT IS STRICTLY PROHIBITED AND ANY INFRINGEMENT THEREUPON MAY BE SUBJECT TO LEGAL ACTION.

ADDITIONAL BASE RAIL ANCHORAGE OPTION

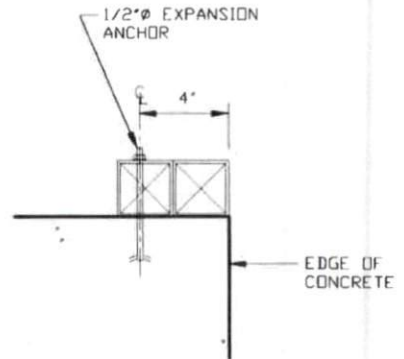
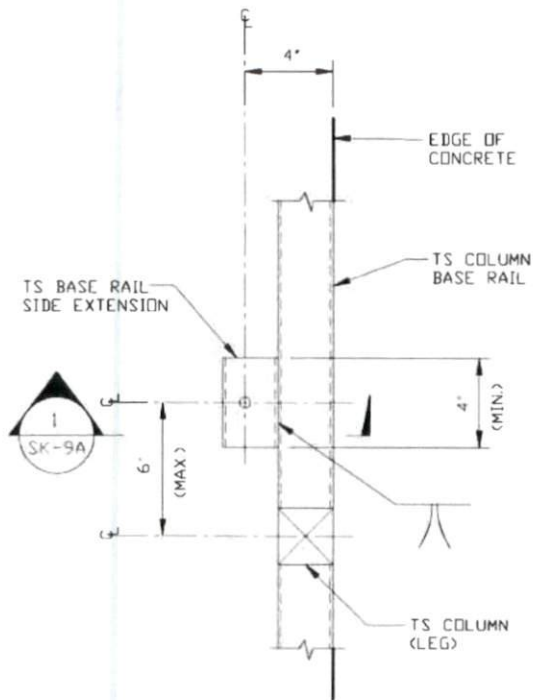

SECTION 1
 SCALE: NTS 1
SK-9A

TYPICAL ANCHOR DETAIL WHEN BASE RAIL IS NEAR EDGE OF CONCRETE

SCALE: NTS

**MOORE AND ASSOCIATES
 ENGINEERING AND CONSULTING, INC.**

DRAWN BY: JG

CHECKED BY: PDH

PROJECT MGR: WSM

CLIENT: VEGA METAL

VEGA METAL STRUCTURES & CONCRETE, LLC.
 4047 US HWY 311
 RANDLEMAN, NC 27317
 30'-0"x20'-0" ENCLOSED STRUCTURE

DATE: 10-23-20

SCALE: NTS

JOB NO: 20193S

SHT. 9A

DWG. NO SK-3

REV: 0

THIS DOCUMENT IS THE PROPERTY OF MOORE AND ASSOCIATES ENGINEERING AND CONSULTING. THE UNAUTHORIZED REPRODUCTION, COPYING, OR OTHERWISE USE OF THIS DOCUMENT IS STRICTLY PROHIBITED AND ANY INFRINGEMENT THEREUPON MAY BE SUBJECT TO LEGAL ACTION.

BOX EAVE RAFTER END WALL AND SIDE WALL OPENINGS

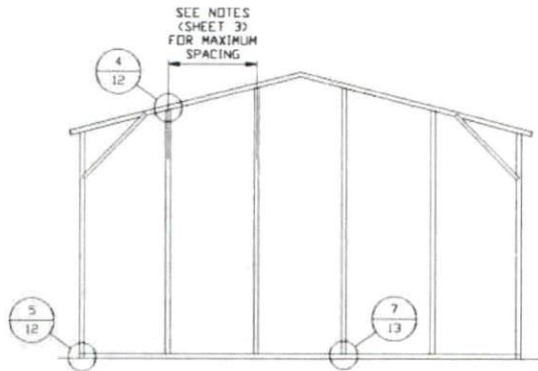

**TYPICAL BOX EAVE RAFTER
END WALL FRAMING SECTION**
SCALE: NTS

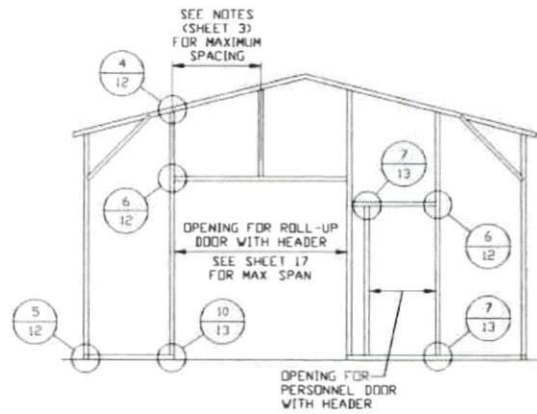

**TYPICAL BOX EAVE RAFTER END WALL
OPENINGS FRAMING SECTION**
SCALE: NTS

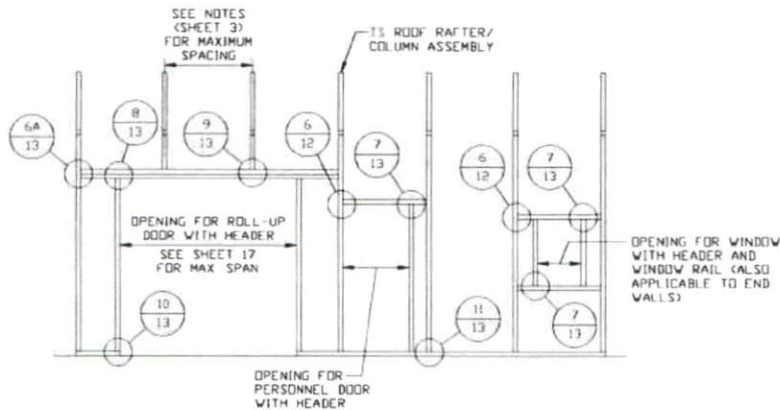

**TYPICAL BOX EAVE RAFTER SIDE
WALL OPENINGS FRAMING SECTION**
SCALE: NTS

**MOORE AND ASSOCIATES
ENGINEERING AND CONSULTING, INC.**

DRAWN BY: JG

CHECKED BY: PDH

PROJECT MGR: VSM

CLIENT: VEGA METAL

VEGA METAL STRUCTURES & CONCRETE, LLC.
4047 US HWY 311
RANDLEMAN, NC 27317
30'-0" x 20'-0" ENCLOSED STRUCTURE

DATE: 10-23-20

SHT. 10

SCALE: NTS

DWG. NO SK-3

JOB NO: 20193S

REV: 0

THIS DOCUMENT IS THE PROPERTY OF MOORE AND ASSOCIATES ENGINEERING AND CONSULTING. THE UNAUTHORIZED REPRODUCTION, COPYING, OR OTHERWISE USE OF THIS DOCUMENT IS STRICTLY PROHIBITED AND ANY INFRINGEMENT THEREUPON MAY BE SUBJECT TO LEGAL ACTION.

BOW RAFTER END WALL AND SIDE WALL OPENINGS

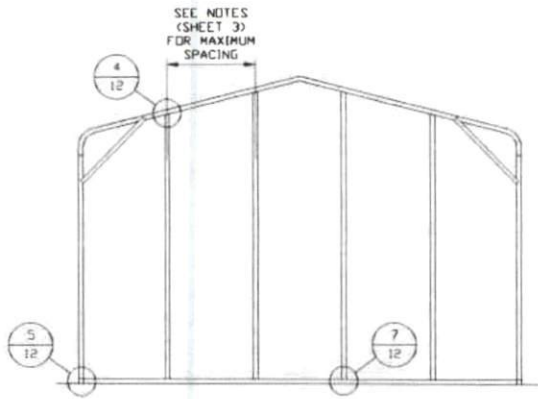

**TYPICAL BOW RAFTER
END WALL FRAMING SECTION**

SCALE: NTS

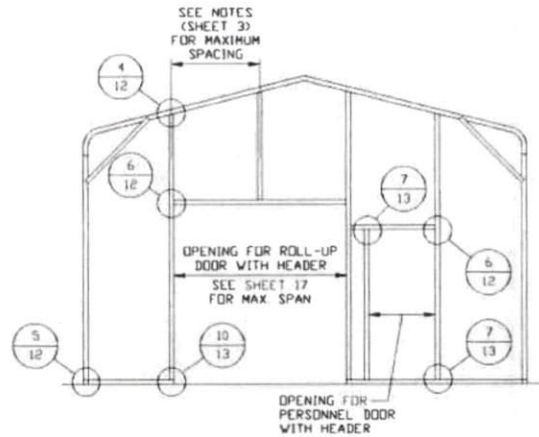

**TYPICAL BOW RAFTER END WALL
OPENINGS FRAMING SECTION**

SCALE: NTS

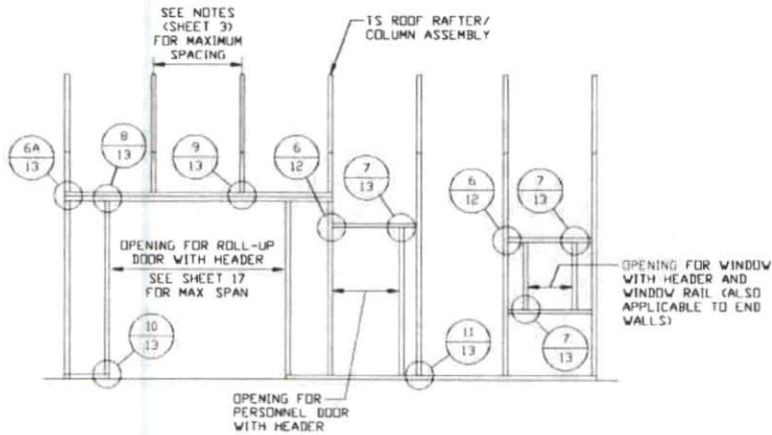

**TYPICAL BOW RAFTER SIDE
WALL OPENINGS FRAMING SECTION**

SCALE: NTS

**MOORE AND ASSOCIATES
ENGINEERING AND CONSULTING, INC.**

DRAWN BY: JG

CHECKED BY: PDH

PROJECT MGR: WSM

CLIENT: VEGA METAL

VEGA METAL STRUCTURES & CONCRETE, LLC.
4047 US HWY 311
RANDLEMAN, NC 27317
30'-0" x 20'-0" ENCLOSED STRUCTURE

DATE: 10-23-20

SCALE: NTS

JOB NO: 20193S

SHT. 11

DWG. NO: SK-3

REV: 0

THIS DOCUMENT IS THE PROPERTY OF MOORE AND ASSOCIATES ENGINEERING AND CONSULTING. THE UNAUTHORIZED REPRODUCTION, COPYING, OR OTHERWISE USE OF THIS DOCUMENT IS STRICTLY PROHIBITED AND ANY INFRINGEMENT THEREUPON MAY BE SUBJECT TO LEGAL ACTION.

CONNECTION DETAILS

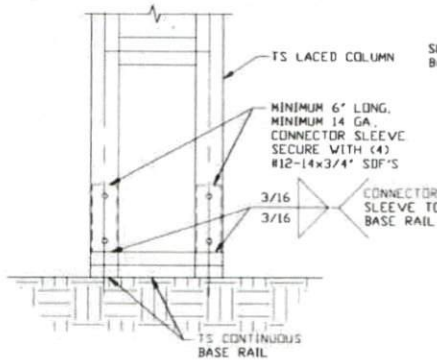

3 RAFTER COLUMN/
BASE RAIL
CONNECTION DETAIL

SCALE: NTS

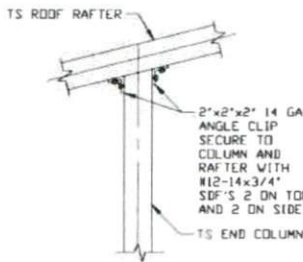

4 END COLUMN/RAFTER
CONNECTION DETAIL

SCALE: NTS

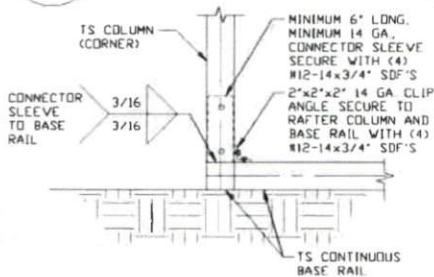

5B

END COLUMN/BASE RAIL
CONNECTION DETAIL

SCALE: NTS

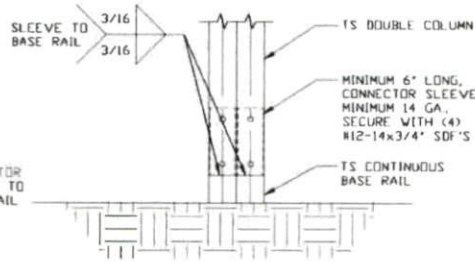

3A

RAFTER COLUMN/
BASE RAIL
CONNECTION DETAIL

SCALE: NTS

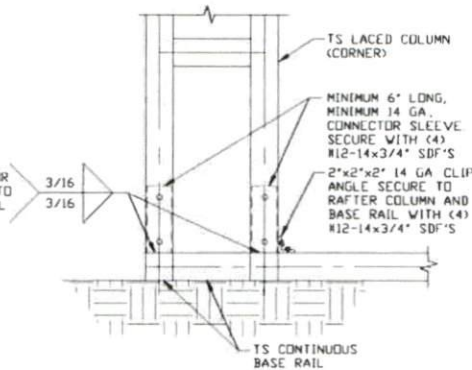

5

END COLUMN/BASE RAIL
CONNECTION DETAIL

SCALE: NTS

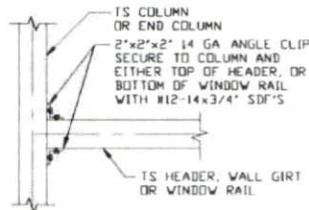

6

COLUMN OR WINDOW
RAIL/WALL GIRT
TO POST
CONNECTION DETAIL

SCALE: NTS

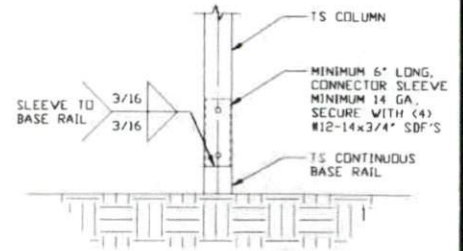

3B

RAFTER COLUMN/
BASE RAIL
CONNECTION DETAIL

SCALE: NTS

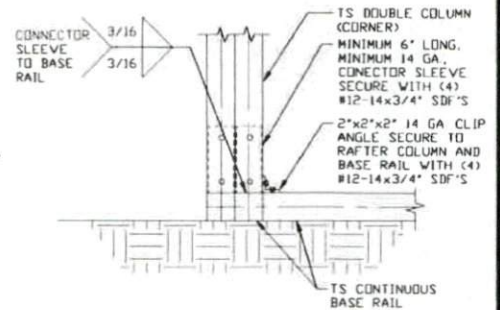

5A

END COLUMN/BASE RAIL
CONNECTION DETAIL

SCALE: NTS

**MOORE AND ASSOCIATES
ENGINEERING AND CONSULTING, INC.**

DRAWN BY: JG

CHECKED BY: PDH

PROJECT MGR: VSM

CLIENT: VEGA METAL

VEGA METAL STRUCTURES & CONCRETE, LLC.
4047 US HWY 311
RANDLEMAN, NC 27317
30'-0" x 20'-0" ENCLOSED STRUCTURE

DATE: 10-23-20

SHT. 12

SCALE: NTS

DWG. NO. SK-3

JOB NO. 20193S

REV: 0

THIS DOCUMENT IS THE PROPERTY OF MOORE AND ASSOCIATES ENGINEERING AND CONSULTING. THE UNAUTHORIZED REPRODUCTION, COPYING, OR OTHERWISE USE OF THIS DOCUMENT IS STRICTLY PROHIBITED AND ANY INFRINGEMENT THEREUPON MAY BE SUBJECT TO LEGAL ACTION.

CONNECTION DETAILS

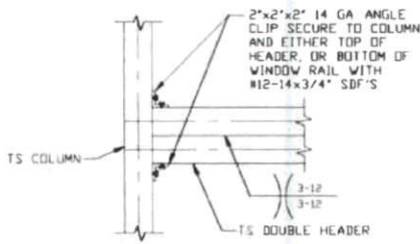

6A
**COLUMN OR DOUBLE
 HEADER TO POST
 CONNECTION DETAIL**
 SCALE: NTS

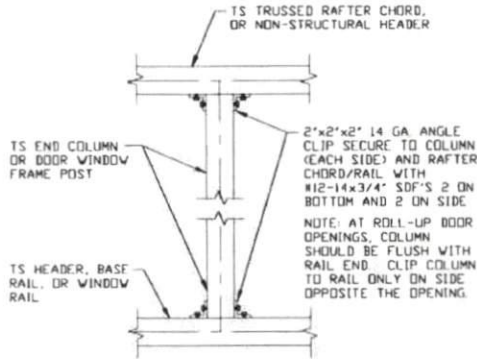

7
**COLUMN TO WINDOW RAIL
 CONNECTION DETAIL**
 SCALE: NTS

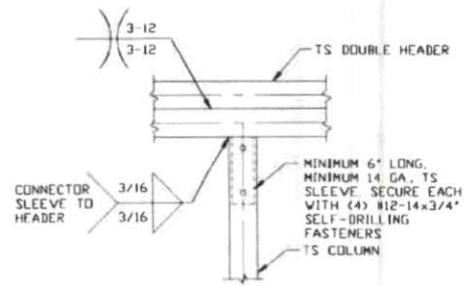

8
**DOUBLE HEADER/
 COLUMN
 CONNECTION DETAIL**
 SCALE: NTS

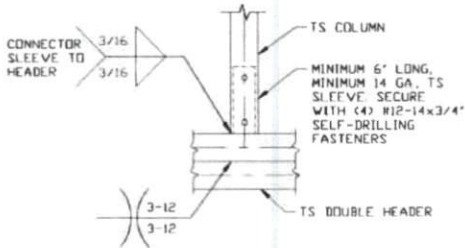

9
**COLUMN/DOUBLE HEADER
 CONNECTION DETAIL**
 SCALE: NTS

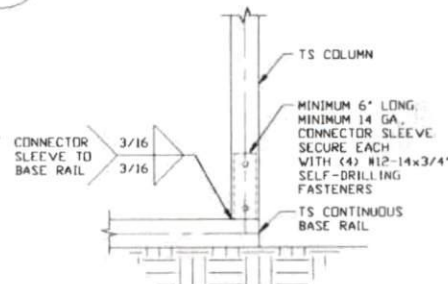

10
**COLUMN/BASE RAIL
 CONNECTION DETAIL**
 SCALE: NTS

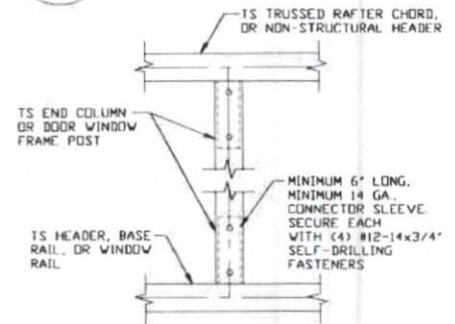

11
**COLUMN TO HEADER
 OR BASE RAIL
 CONNECTION DETAIL**
 SCALE: NTS

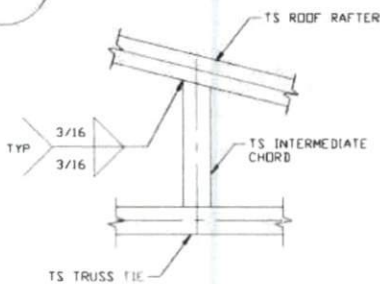

12
**RAFTER TO CHORD
 CONNECTION DETAIL**
 SCALE: NTS

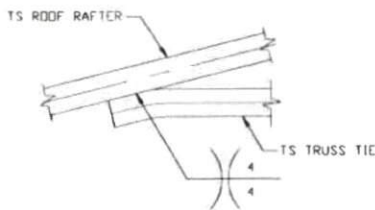

13
**COLLAR TIE
 CONNECTION DETAIL**
 SCALE: NTS

**MOORE AND ASSOCIATES
 ENGINEERING AND CONSULTING, INC.**

DRAWN BY: JG

CHECKED BY: PDH

PROJECT MGR: WSM

CLIENT: VEGA METAL

VEGA METAL STRUCTURES & CONCRETE, L.L.C.
 4047 US HWY 311
 RANDLEMAN, NC 27317
 30'-0" x 20'-0" ENCLOSED STRUCTURE

DATE: 10-23-20

SHT. 13

SCALE: NTS

DWG. NO: SK-3

JOB NO: P0193S

REV: 0

THIS DOCUMENT IS THE PROPERTY OF MOORE AND ASSOCIATES ENGINEERING AND CONSULTING. THE UNAUTHORIZED REPRODUCTION, COPYING, OR OTHERWISE USE OF THIS DOCUMENT IS STRICTLY PROHIBITED AND ANY INFRINGEMENT THEREUPON MAY BE SUBJECT TO LEGAL ACTION.

BOX EAVE RAFTER LEAN-TO OPTIONS

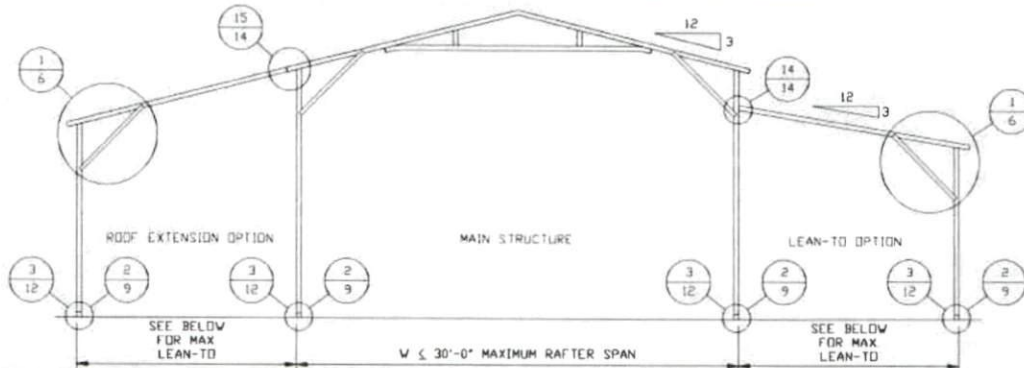

TYPICAL BOX EAVE RAFTER LEAN-TO OPTIONS FRAMING SECTION (BOTH OPTIONS SHOWN)

SCALE: NTS

MAXIMUM WIDTH OF SINGLE MEMBER ROOF EXTENSION AND LEAN-TO IS 10'-0"

MAXIMUM WIDTH OF DOUBLE MEMBER ROOF EXTENSION AND LEAN-TO IS 16'-0"

MAXIMUM WIDTH OF LACED MEMBER ROOF EXTENSION AND LEAN-TO IS 20'-0"

FOR SHARED COLUMN HEIGHTS REFERENCE RAFTER COLUMN CONNECTION DETAILS FOR APPROPRIATE COLUMN HEIGHT AND TUBING SPECIFICATIONS.

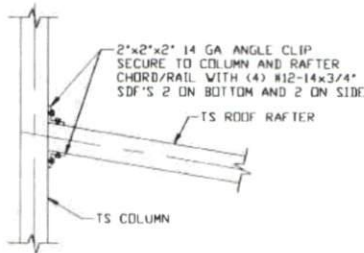

14 LEAN-TO RAFTER TO RAFTER COLUMN CONNECTION DETAIL FOR RAFTER SPANS $\leq 10'-0''$

SCALE: NTS

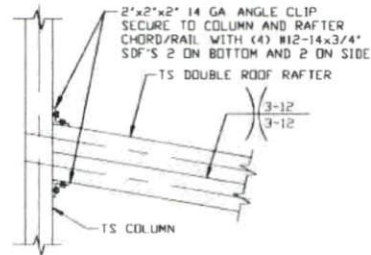

14A LEAN-TO RAFTER TO RAFTER COLUMN CONNECTION DETAIL FOR RAFTER SPANS $10'-0'' < \text{TO} \leq 16'-0''$

SCALE: NTS

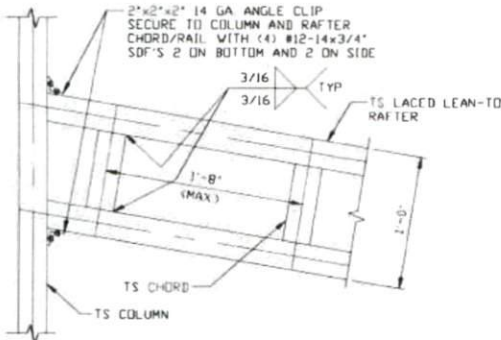

14B LEAN-TO RAFTER TO RAFTER COLUMN CONNECTION DETAIL FOR RAFTER SPANS $16'-0'' < \text{TO} \leq 20'-0''$

SCALE: NTS

**MOORE AND ASSOCIATES
ENGINEERING AND CONSULTING, INC.**

DRAWN BY: JG

CHECKED BY: PDH

PROJECT MGR: WSM

CLIENT: VEGA METAL

VEGA METAL STRUCTURES & CONCRETE, LLC.
4047 US HWY 311
RANDLEMAN, NC 27317
30'-0"x20'-0" ENCLOSED STRUCTURE

DATE: 10-23-20

SHT. 14

SCALE: NTS

DWG. NO: SK-3

JOB NO: 20193S

REV: 0

THIS DOCUMENT IS THE PROPERTY OF MOORE AND ASSOCIATES ENGINEERING AND CONSULTING. THE UNAUTHORIZED REPRODUCTION, COPYING, OR OTHERWISE USE OF THIS DOCUMENT IS STRICTLY PROHIBITED AND ANY INFRINGEMENT THEREUPON MAY BE SUBJECT TO LEGAL ACTION.

BOX EAVE RAFTER LEAN-TO OPTION FOR RAFTER SPANS $\leq 10'-0''$

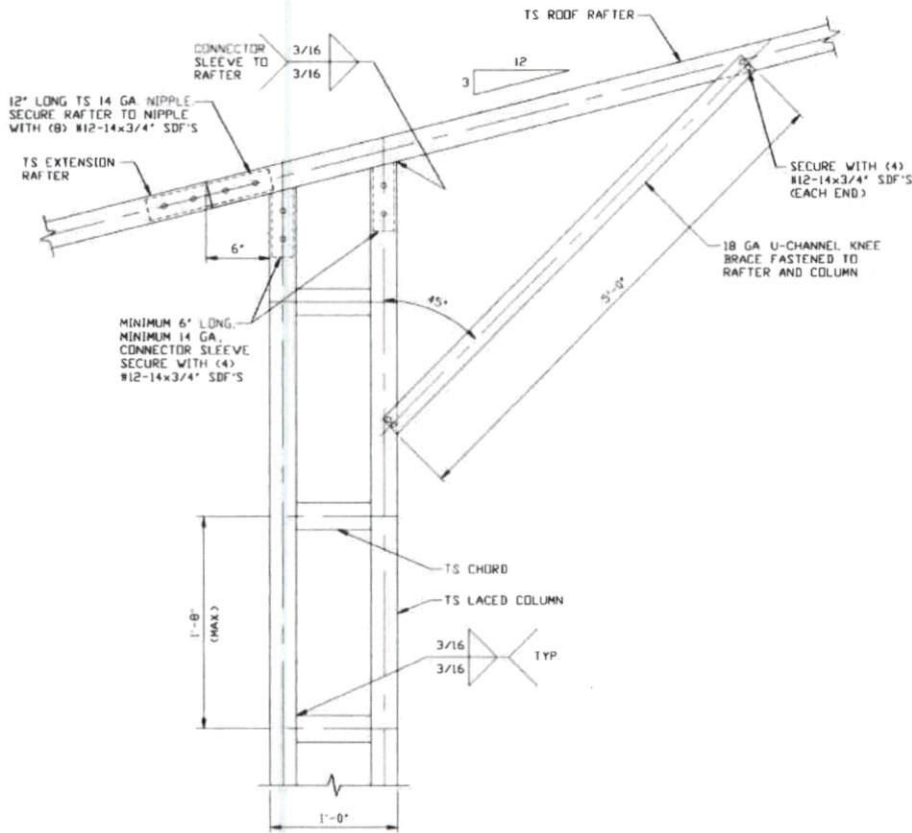

**SIDE EXTENSION RAFTER/
COLUMN DETAIL FOR
HEIGHTS 16'-0" < TO \leq 20'-0"**

15

SCALE: NTS

**MOORE AND ASSOCIATES
ENGINEERING AND CONSULTING, INC.**

DRAWN BY: JG

CHECKED BY: PDH

PROJECT MGR: WSM

CLIENT: VEGA METAL

VEGA METAL STRUCTURES & CONCRETE, LLC.
4047 US HWY 311
RANDLEMAN, NC 27317
30'-0"x20'-0" ENCLOSED STRUCTURE

DATE: 10-23-20

SCALE: NTS

JOB NO: 20193S

SHT. 14A

DWG. NO: SK-3

REV: 0

THIS DOCUMENT IS THE PROPERTY OF MOORE AND ASSOCIATES ENGINEERING AND CONSULTING. THE UNAUTHORIZED REPRODUCTION, COPYING, OR OTHERWISE USE OF THIS DOCUMENT IS STRICTLY PROHIBITED AND ANY INFRINGEMENT THEREUPON MAY BE SUBJECT TO LEGAL ACTION.

BOX EAVE RAFTER LEAN-TO OPTIONS FOR RAFTER SPANS $\leq 10'-0''$

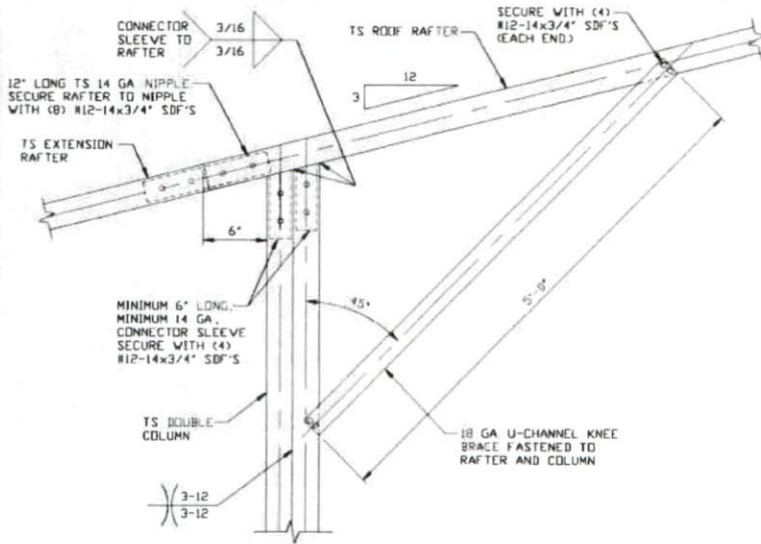

15A SIDE EXTENSION RAFTER/
COLUMN DETAIL FOR
HEIGHTS $12'-0'' < TO \leq 16'-0''$
SCALE: NTS

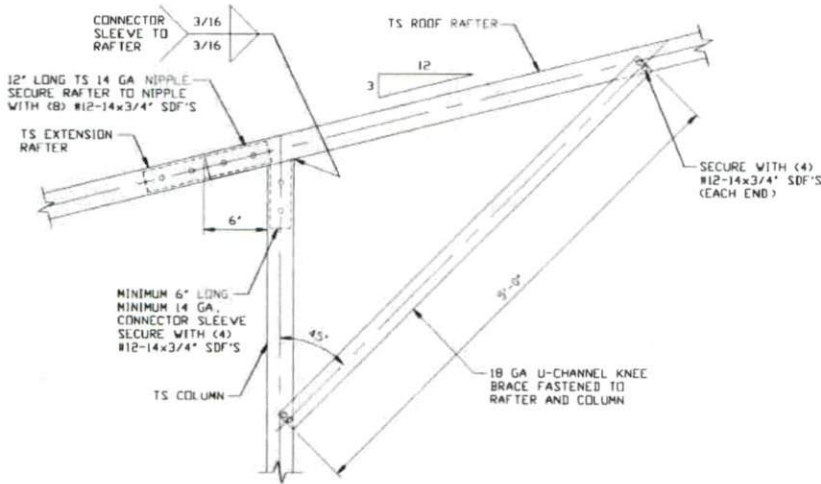

15B SIDE EXTENSION RAFTER/
COLUMN DETAIL FOR
HEIGHTS $< 12'-0''$
SCALE: NTS

**MOORE AND ASSOCIATES
ENGINEERING AND CONSULTING, INC.**

DRAWN BY: JG

CHECKED BY: PDH

PROJECT MGR: VSM

CLIENT: VEGA METAL

VEGA METAL STRUCTURES & CONCRETE, LLC.
4047 US HWY 311
RANDLEMAN, NC 27317
30'-0" x 20'-0" ENCLOSED STRUCTURE

DATE: 10-23-20

SHT. 14B

SCALE: NTS

DWG. NO SK-3

JOB NO: 20193S

REV: 0

THIS DOCUMENT IS THE PROPERTY OF MOORE AND ASSOCIATES ENGINEERING AND CONSULTING. THE UNAUTHORIZED REPRODUCTION, COPYING, OR OTHERWISE USE OF THIS DOCUMENT IS STRICTLY PROHIBITED AND ANY INFRINGEMENT THEREUPON MAY BE SUBJECT TO LEGAL ACTION.

BOX EAVE RAFTER LEAN-TO OPTION FOR RAFTER SPANS 10'-0" < TO ≤ 16'-0"

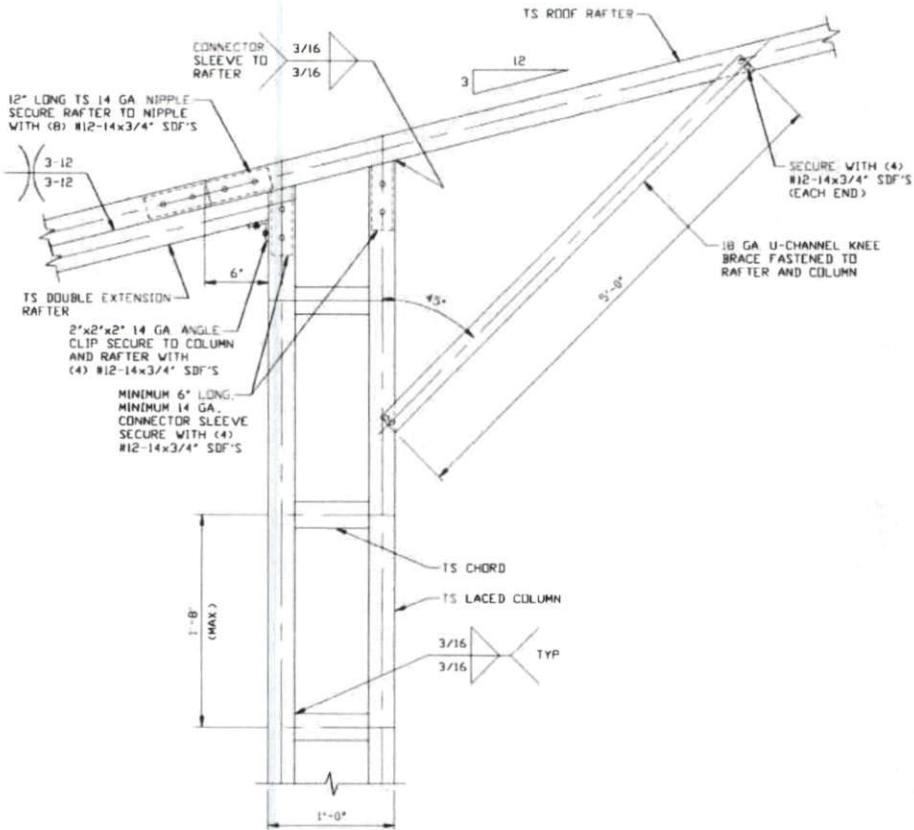

**SIDE EXTENSION RAFTER/
COLUMN DETAIL FOR
HEIGHTS 16'-0" < TO ≤ 20'-0"**

15C

SCALE: NTS

**MOORE AND ASSOCIATES
ENGINEERING AND CONSULTING, INC.**

DRAWN BY: JG

CHECKED BY: PDH

PROJECT MGR: WSM

CLIENT: VEGA METAL

VEGA METAL STRUCTURES & CONCRETE, L.L.C.
4047 US HWY 311
RANDLEMAN, NC 27317
30'-0"x20'-0" ENCLOSED STRUCTURE

DATE: 10-23-20

SHT. 14C

SCALE: NTS

DWG. NO: SK-3

JOB NO: 20193S

REV: 0

THIS DOCUMENT IS THE PROPERTY OF MOORE AND ASSOCIATES ENGINEERING AND CONSULTING. THE UNAUTHORIZED REPRODUCTION, COPYING, OR OTHERWISE USE OF THIS DOCUMENT IS STRICTLY PROHIBITED AND ANY INFRINGEMENT THEREUPON MAY BE SUBJECT TO LEGAL ACTION.

BOX EAVE RAFTER LEAN-TO OPTIONS FOR RAFTER SPANS 10'-0" < TO ≤ 16'-0"

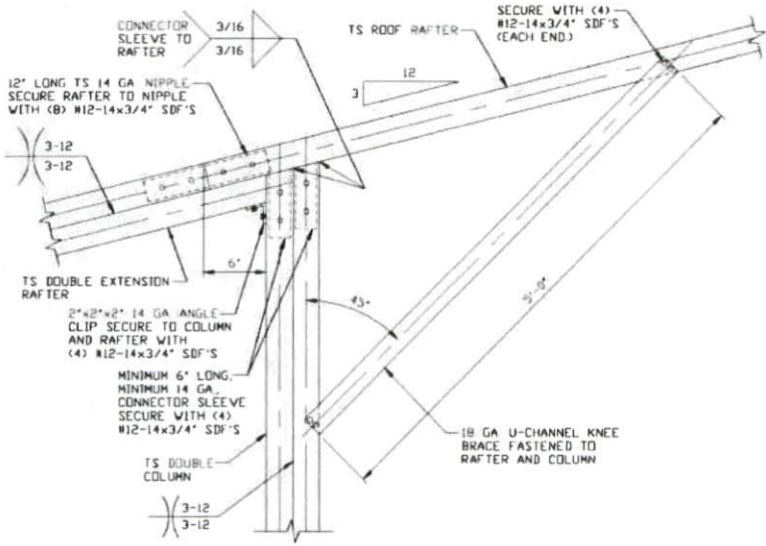

15D SIDE EXTENSION RAFTER/
COLUMN DETAIL FOR
HEIGHTS 12'-0" < TO ≤ 16'-0"
SCALE: NTS

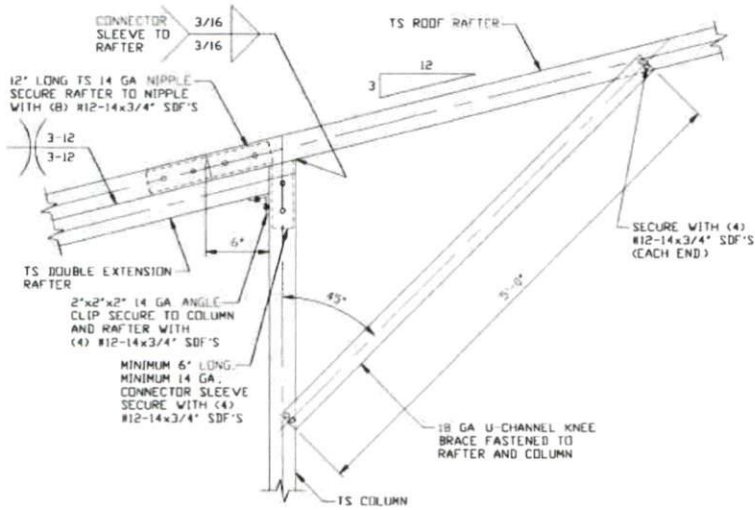

15E SIDE EXTENSION RAFTER/
COLUMN DETAIL FOR
HEIGHTS ≤ 12'-0"
SCALE: NTS

MOORE AND ASSOCIATES ENGINEERING AND CONSULTING, INC.	DRAWN BY: JG	VEGA METAL STRUCTURES & CONCRETE, LLC. 4047 US HWY 311 RANDLEMAN, NC 27317 30'-0" x 20'-0" ENCLOSED STRUCTURE		
	CHECKED BY: PDH			
PROJECT MGR: WSM	DATE: 10-23-20	SCALE: NTS	JOB NO: 20193S	
CLIENT: VEGA METAL	SHT. 14D	DWG. NO SK-3	REV: 0	

THIS DOCUMENT IS THE PROPERTY OF MOORE AND ASSOCIATES ENGINEERING AND CONSULTING. THE UNAUTHORIZED REPRODUCTION, COPYING, OR OTHERWISE USE OF THIS DOCUMENT IS STRICTLY PROHIBITED AND ANY INFRINGEMENT THEREUPON MAY BE SUBJECT TO LEGAL ACTION.

BOX EAVE RAFTER LEAN-TO OPTION FOR RAFTER SPANS 16'-0" < TO ≤ 20'-0"

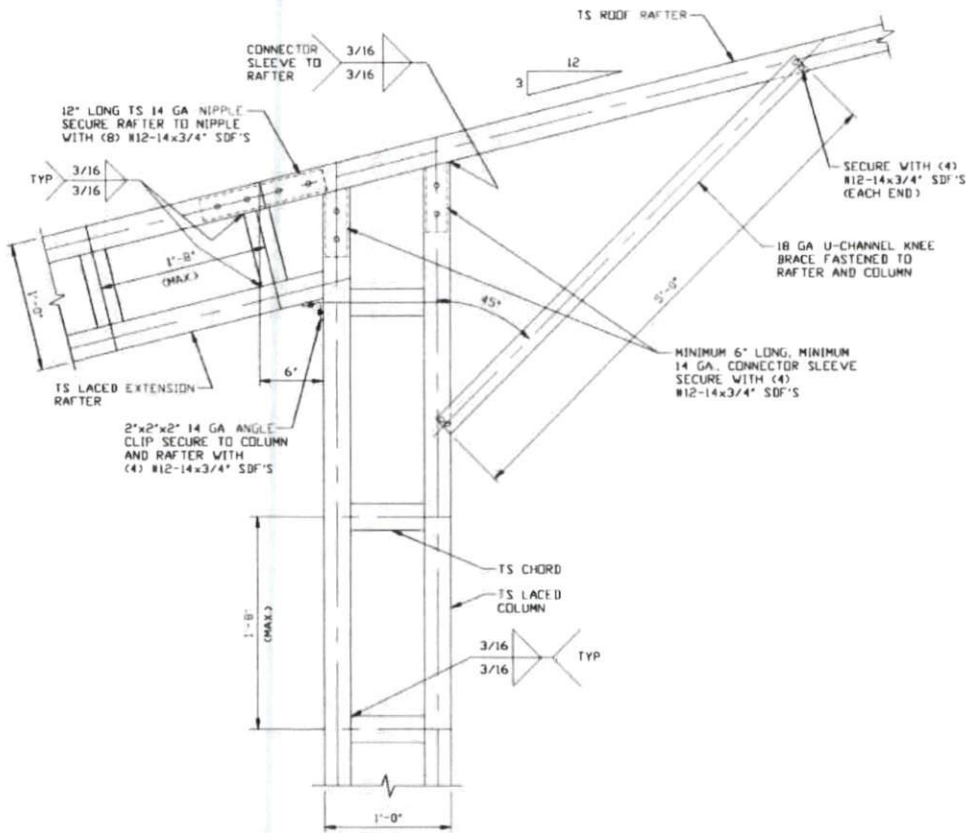

**SIDE EXTENSION RAFTER/
COLUMN DETAIL FOR
HEIGHTS 16'-0" < TO ≤ 20'-0"**
SCALE: NTS

15F

MOORE AND ASSOCIATES ENGINEERING AND CONSULTING, INC.	DRAWN BY: JG	VEGA METAL STRUCTURES & CONCRETE, LLC. 4047 US HWY 311 RANDLEMAN, NC 27317 30'-0"x20'-0" ENCLOSED STRUCTURE		
	CHECKED BY: PDH			
THIS DOCUMENT IS THE PROPERTY OF MOORE AND ASSOCIATES ENGINEERING AND CONSULTING. THE UNAUTHORIZED REPRODUCTION, COPYING, OR OTHERWISE USE OF THIS DOCUMENT IS STRICTLY PROHIBITED AND ANY INFREINGEMENT THEREUPON MAY BE SUBJECT TO LEGAL ACTION.	PROJECT MGR: VSM	DATE: 10-23-20	SCALE: NTS	JOB NO: 201935
	CLIENT: VEGA METAL	SHT. 14E	DWG. NO: SK-3	REV: 0

BOX EAVE RAFTER LEAN-TO OPTIONS FOR RAFTER SPANS 16'-0" < TO ≤ 20'-0"

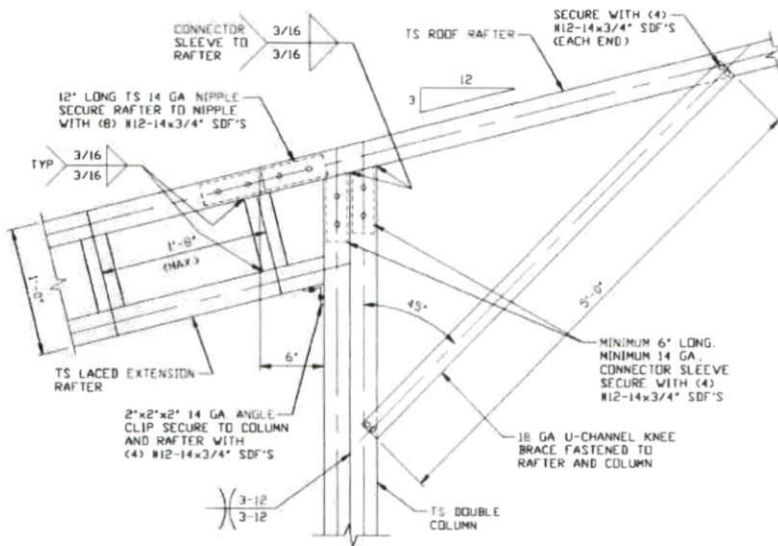

**SIDE EXTENSION RAFTER/
COLUMN DETAIL FOR
HEIGHTS 12'-0" < TO ≤ 16'-0"**

15G

SCALE: NTS

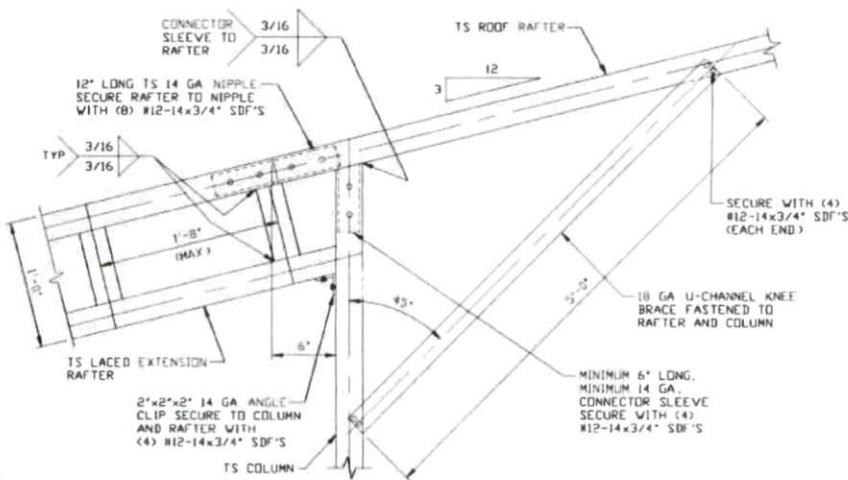

**SIDE EXTENSION RAFTER/
COLUMN DETAIL FOR
HEIGHTS ≤ 12'-0"**

15H

SCALE: NTS

**MOORE AND ASSOCIATES
ENGINEERING AND CONSULTING, INC.**

DRAWN BY: JG

CHECKED BY: PDH

PROJECT MGR: WSM

CLIENT: VEGA METAL

VEGA METAL STRUCTURES & CONCRETE, LLC.
4047 US HWY 311
RANDLEMAN, NC 27317
30'-0" x 20'-0" ENCLOSED STRUCTURE

DATE: 10-23-20

SCALE: NTS

JOB NO: 20193S

SHT. 14F

DWG. NO: SK-3

REV: 0

THIS DOCUMENT IS THE PROPERTY OF MOORE AND ASSOCIATES ENGINEERING AND CONSULTING. THE UNAUTHORIZED REPRODUCTION, COPYING, OR OTHERWISE USE OF THIS DOCUMENT IS STRICTLY PROHIBITED AND ANY INFRINGEMENT THEREUPON MAY BE SUBJECT TO LEGAL ACTION.

BOW EAVE RAFTER LEAN-TO OPTION

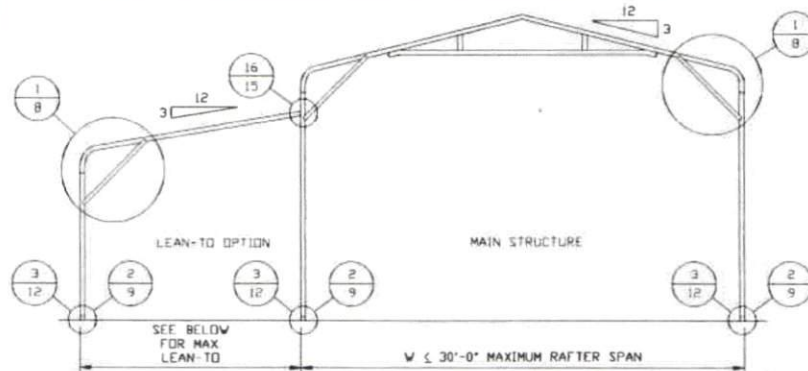

TYPICAL BOW EAVE RAFTER LEAN-TO OPTION FRAMING SECTION

SCALE: NTS

MAXIMUM WIDTH OF SINGLE MEMBER ROOF EXTENSION AND LEAN-TO IS 10'-0\"

MAXIMUM WIDTH OF DOUBLE MEMBER ROOF EXTENSION AND LEAN-TO IS 16'-0\"

MAXIMUM WIDTH OF LACED MEMBER ROOF EXTENSION AND LEAN-TO IS 20'-0\"

FOR SHARED COLUMN HEIGHTS REFERENCE RAFTER COLUMN CONNECTION DETAILS FOR APPROPRIATE COLUMN HEIGHT AND TUBING SPECIFICATIONS.

**MOORE AND ASSOCIATES
ENGINEERING AND CONSULTING, INC.**

DRAWN BY: JG

CHECKED BY: PDH

PROJECT MGR: WSH

CLIENT: VEGA METAL

VEGA METAL STRUCTURES & CONCRETE, LLC.
4047 US HWY 311
RANDLEMAN, NC 27317
30'-0"x20'-0" ENCLOSED STRUCTURE

DATE: 10-23-20

SHT. 15

SCALE: NTS

DWG. NO: SK-3

JOB NO: 20193S

REV: 0

THIS DOCUMENT IS THE PROPERTY OF MOORE AND ASSOCIATES ENGINEERING AND CONSULTING. THE UNAUTHORIZED REPRODUCTION, COPYING, OR OTHERWISE USE OF THIS DOCUMENT IS STRICTLY PROHIBITED AND ANY INFRINGEMENT THEREUPON MAY BE SUBJECT TO LEGAL ACTION.

BOW EAVE RAFTER LEAN-TO OPTION FOR RAFTER SPANS $\leq 10'-0''$

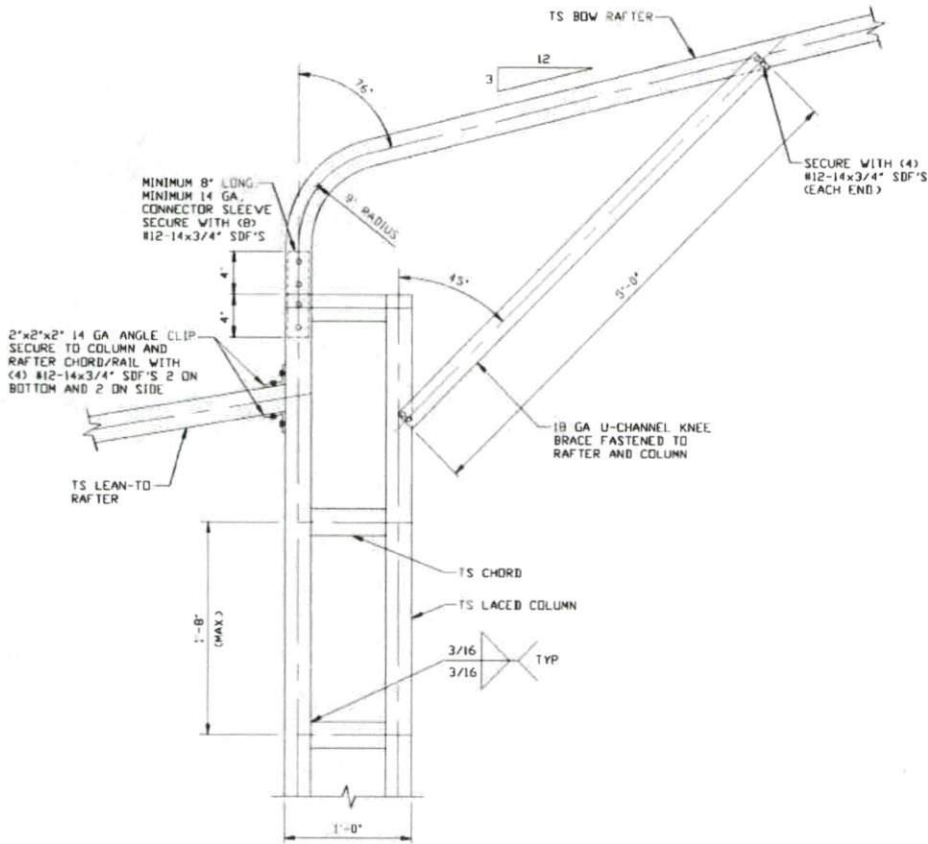

**SIDE EXTENSION RAFTER/
COLUMN DETAIL FOR
HEIGHTS 16'-0" < TO ≤ 20'-0"**

16

SCALE: NTS

**MOORE AND ASSOCIATES
ENGINEERING AND CONSULTING, INC.**

DRAWN BY: JG
CHECKED BY: PDH

VEGA METAL STRUCTURES & CONCRETE, LLC.
4047 US HWY 311
RANDLEMAN, NC 27317
30'-0"x20'-0" ENCLOSED STRUCTURE

THIS DOCUMENT IS THE PROPERTY OF MOORE AND ASSOCIATES ENGINEERING AND CONSULTING. THE UNAUTHORIZED REPRODUCTION, COPYING, OR OTHERWISE USE OF THIS DOCUMENT IS STRICTLY PROHIBITED AND ANY INFRINGEMENT THEREUPON MAY BE SUBJECT TO LEGAL ACTION.

PROJECT MGR: WSM	DATE: 10-23-20	SCALE: NTS	JOB NO: 20193S
CLIENT: VEGA METAL	SHT. 15A	DWG. NO SK-3	REV: 0

BOW EAVE RAFTER LEAN-TO OPTIONS FOR RAFTER SPANS $\leq 10'-0''$

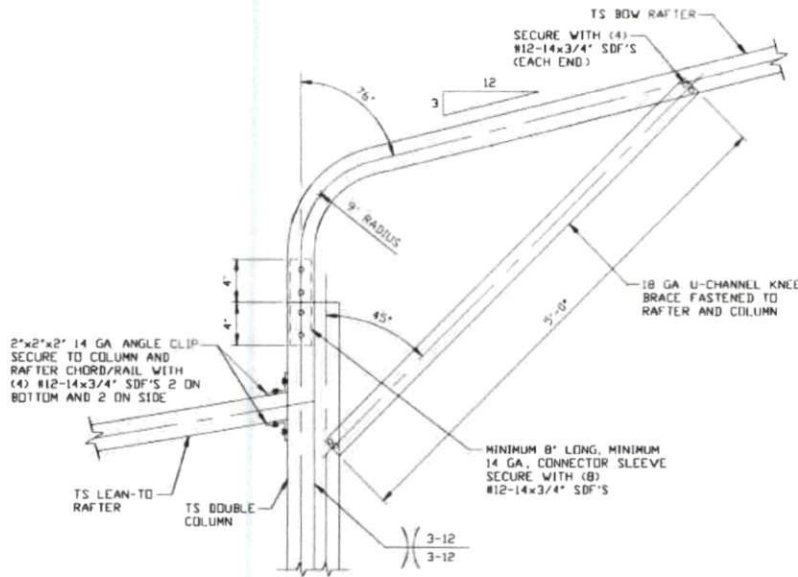

16A
**SIDE EXTENSION RAFTER/
 COLUMN DETAIL FOR
 HEIGHTS 12'-0" < TO ≤ 16'-0"**
 SCALE: NTS

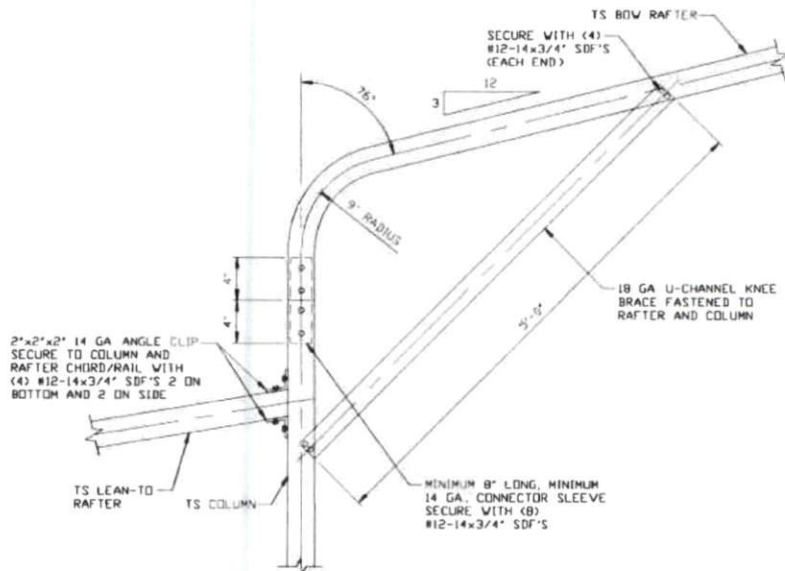

16B
**SIDE EXTENSION RAFTER/
 COLUMN DETAIL FOR
 HEIGHTS $< 12'-0''$**
 SCALE: NTS

**MOORE AND ASSOCIATES
 ENGINEERING AND CONSULTING, INC.**

DRAWN BY: JG
CHECKED BY: PDH
PROJECT MGR: WSH
CLIENT: VEGA METAL

VEGA METAL STRUCTURES & CONCRETE, LLC.
 4047 US HWY 311
 RANDLEMAN, NC 27317
 30'-0" x 20'-0" ENCLOSED STRUCTURE

DATE: 10-23-20 **SCALE: NTS** **JOB NO: 20193S**
SHT. 15B **DWG. NO SK-3** **REV: 0**

THIS DOCUMENT IS THE PROPERTY OF MOORE AND ASSOCIATES ENGINEERING AND CONSULTING. THE UNAUTHORIZED REPRODUCTION, COPYING, OR OTHERWISE USE OF THIS DOCUMENT IS STRICTLY PROHIBITED AND ANY INFRINGEMENT THEREUPON MAY BE SUBJECT TO LEGAL ACTION.

BOW EAVE RAFTER LEAN-TO OPTION FOR RAFTER SPANS 10'-0" < TO ≤ 16'-0"

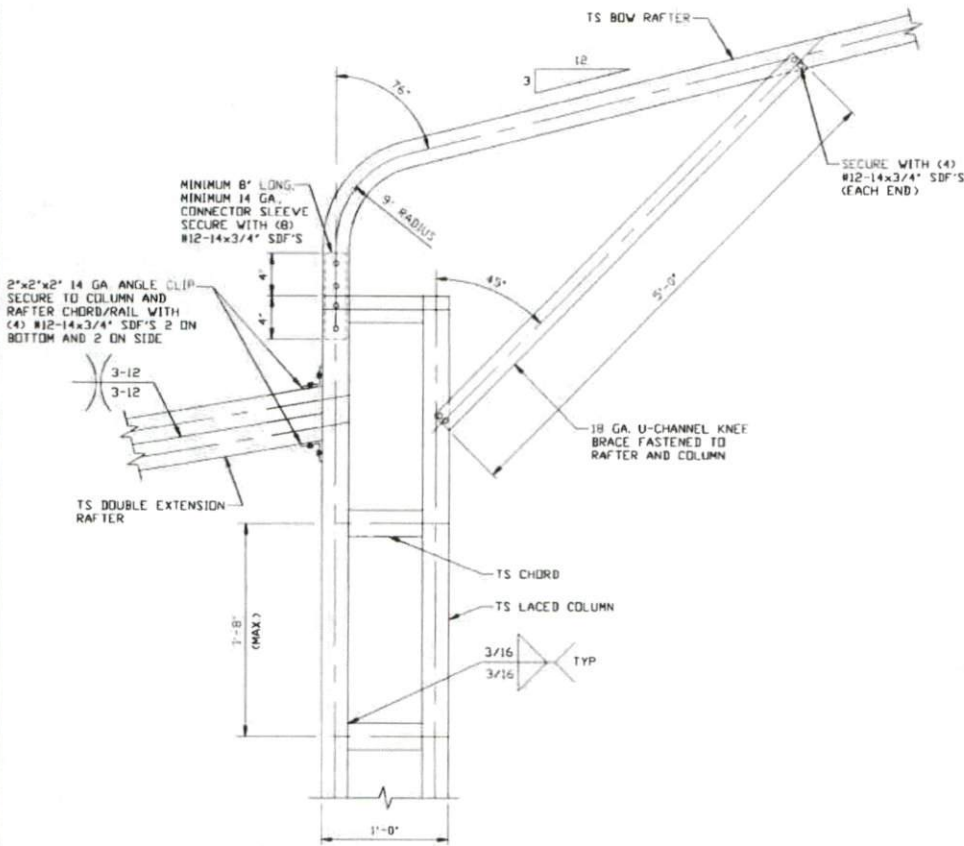

**SIDE EXTENSION RAFTER/
COLUMN DETAIL FOR
HEIGHTS 16'-0" < TO ≤ 20'-0"**

16C

SCALE: NTS

**MOORE AND ASSOCIATES
ENGINEERING AND CONSULTING, INC.**

DRAWN BY: JG

CHECKED BY: PDH

PROJECT MGR: WSM

CLIENT: VEGA METAL

VEGA METAL STRUCTURES & CONCRETE, LLC.
4047 US HWY 311
RANDLEMAN, NC 27317
30'-0"x20'-0" ENCLOSED STRUCTURE

DATE: 10-23-20

SCALE: NTS

JOB NO: 20193S

SHT. 15C

DWG. NO: SK-3

REV: 0

THIS DOCUMENT IS THE PROPERTY OF MOORE AND ASSOCIATES ENGINEERING AND CONSULTING. THE UNAUTHORIZED REPRODUCTION, COPYING, OR OTHERWISE USE OF THIS DOCUMENT IS STRICTLY PROHIBITED AND ANY INFRINGEMENT THEREUPON MAY BE SUBJECT TO LEGAL ACTION.

BOW EAVE RAFTER LEAN-TO OPTIONS FOR RAFTER SPANS 10'-0" < TO ≤ 16'-0"

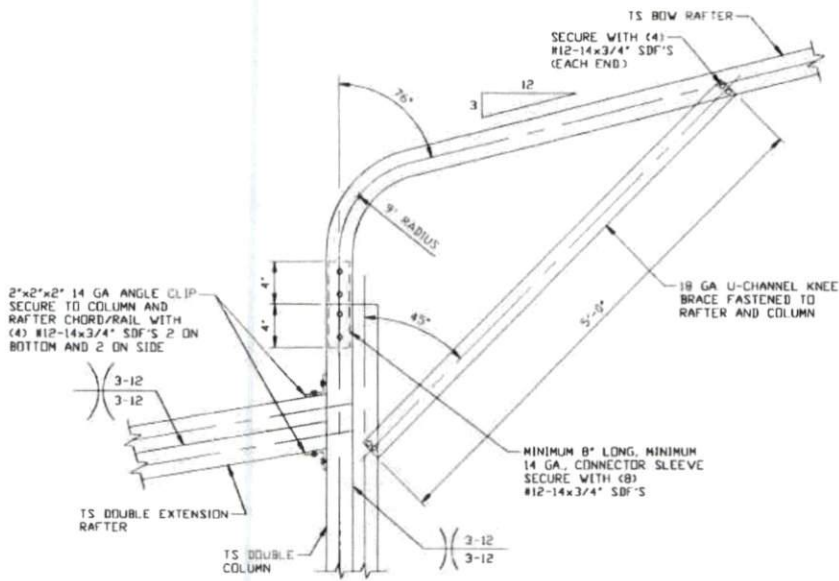

16D

**SIDE EXTENSION RAFTER/
COLUMN DETAIL FOR
HEIGHTS 12'-0" < TO ≤ 16'-0"**
SCALE: NTS

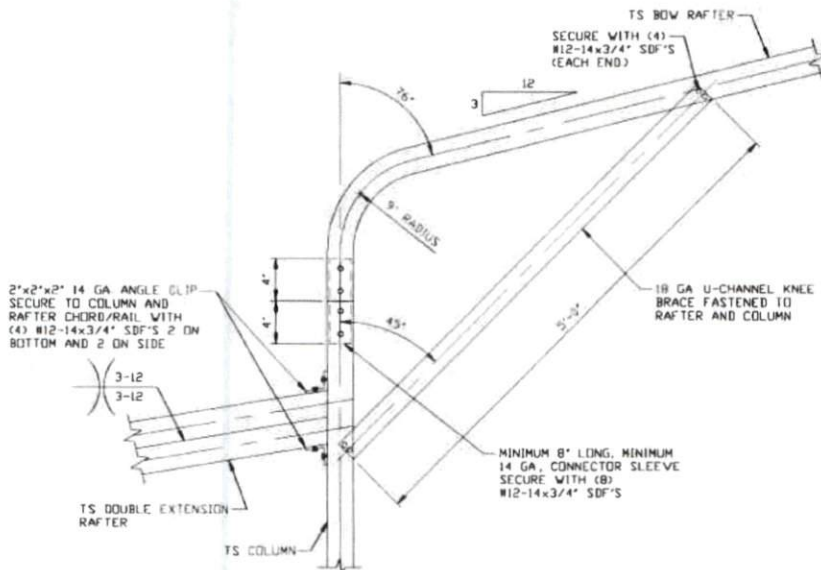

16E

**SIDE EXTENSION RAFTER/
COLUMN DETAIL FOR
HEIGHTS < 12'-0"**
SCALE: NTS

**MOORE AND ASSOCIATES
ENGINEERING AND CONSULTING, INC.**

DRAWN BY: JG

CHECKED BY: PDH

PROJECT MGR: WSH

CLIENT: VEGA METAL

VEGA METAL STRUCTURES & CONCRETE, LLC.
4047 US HWY 311
RANDLEMAN, NC 27317
30'-0"x20'-0" ENCLOSED STRUCTURE

DATE: 10-23-20

SHT. 15D

SCALE: NTS

DWG. NO: SK-3

JOB NO: 20193S

REV: 0

THIS DOCUMENT IS THE PROPERTY OF MOORE AND ASSOCIATES ENGINEERING AND CONSULTING. THE UNAUTHORIZED REPRODUCTION, COPYING, OR OTHERWISE USE OF THIS DOCUMENT IS STRICTLY PROHIBITED AND ANY INFRINGEMENT THEREUPON MAY BE SUBJECT TO LEGAL ACTION.

BOW EAVE RAFTER LEAN-TO OPTION FOR RAFTER SPANS 16'-0" < TO ≤ 20'-0"

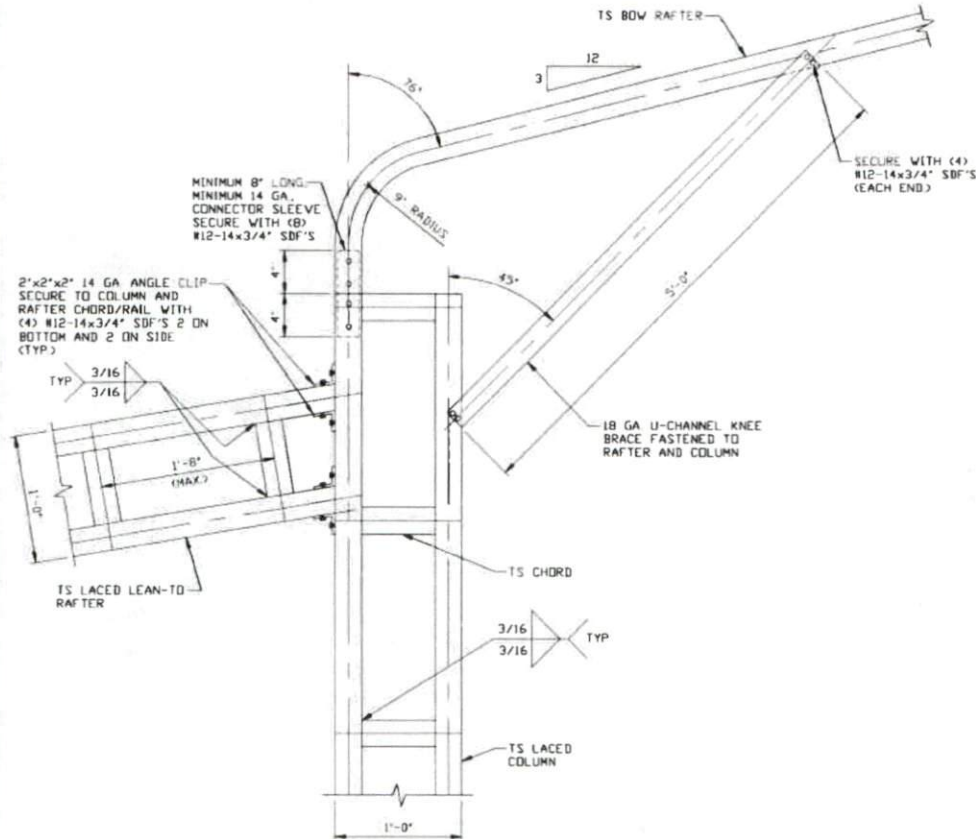

**SIDE EXTENSION RAFTER/
COLUMN DETAIL FOR
HEIGHTS 16'-0" < TO ≤ 20'-0"**
SCALE: NTS

16F

MOORE AND ASSOCIATES ENGINEERING AND CONSULTING, INC.	DRAWN BY: JG		VEGA METAL STRUCTURES & CONCRETE, LLC. 4047 US HWY 311 RANDLEMAN, NC 27317 30'-0"x20'-0" ENCLOSED STRUCTURE	
	CHECKED BY: PDH			
THIS DOCUMENT IS THE PROPERTY OF MOORE AND ASSOCIATES ENGINEERING AND CONSULTING. THE UNAUTHORIZED REPRODUCTION, COPYING, OR OTHERWISE USE OF THIS DOCUMENT IS STRICTLY PROHIBITED AND ANY INFRINGEMENT THEREUPON MAY BE SUBJECT TO LEGAL ACTION.	PROJECT MGR: WSH	DATE: 10-23-20	SCALE: NTS	JOB NO: 20193S
	CLIENT: VEGA METAL	SHT. 15E	DWG. NO: SK-3	REV: 0

BOW EAVE RAFTER LEAN-TO OPTIONS FOR RAFTER SPANS 16'-0" < TO ≤ 20'-0"

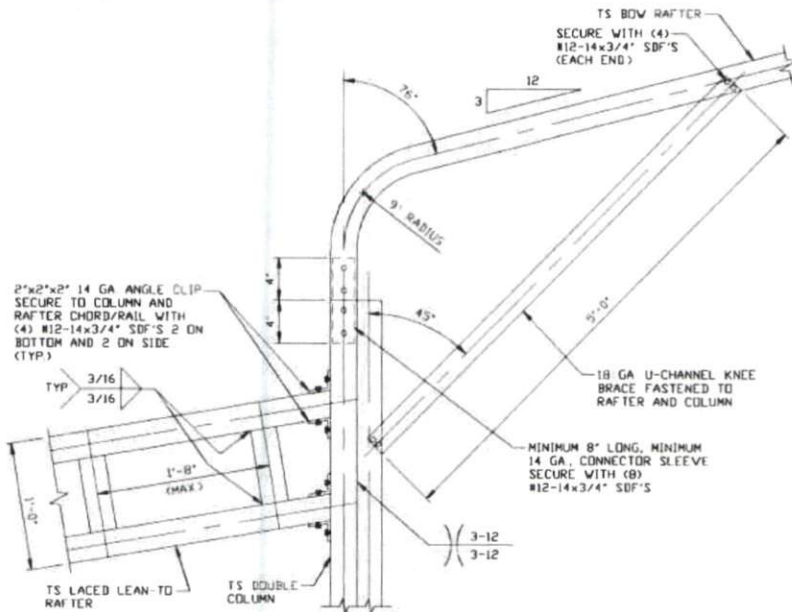

**SIDE EXTENSION RAFTER/
COLUMN DETAIL FOR
HEIGHTS 12'-0" < TO ≤ 16'-0"**

16G

SCALE: NTS

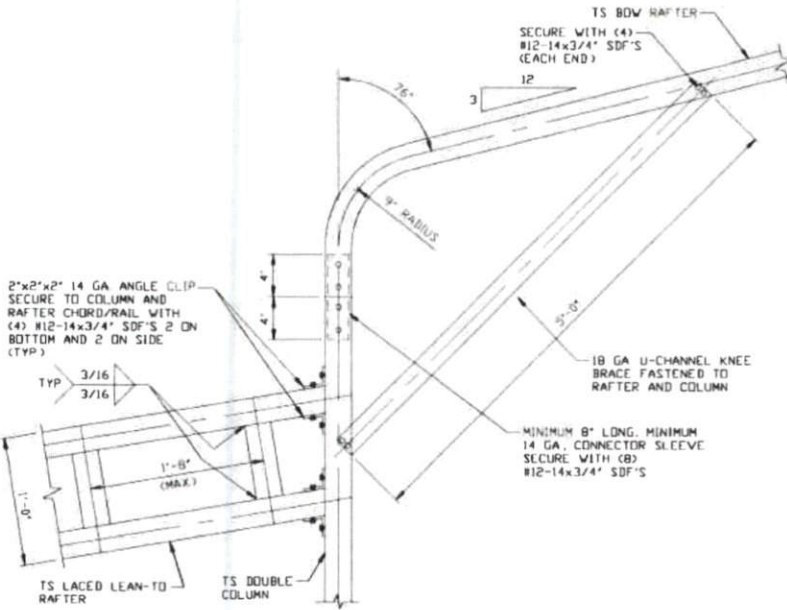

**SIDE EXTENSION RAFTER/
COLUMN DETAIL FOR
HEIGHTS ≤ 12'-0"**

16H

SCALE: NTS

**MOORE AND ASSOCIATES
ENGINEERING AND CONSULTING, INC.**

DRAWN BY: JG

CHECKED BY: PDH

PROJECT MGR: WSH

CLIENT: VEGA METAL

VEGA METAL STRUCTURES & CONCRETE, LLC.
4047 US HWY 311
RANDLEMAN, NC 27317
30'-0"x20'-0" ENCLOSED STRUCTURE

DATE: 10-23-20

SHT. 15F

SCALE: NTS

DWG. NO: SK-3

JOB NO: 20193S

REV: 0

THIS DOCUMENT IS THE PROPERTY OF MOORE AND ASSOCIATES ENGINEERING AND CONSULTING. THE UNAUTHORIZED REPRODUCTION, COPYING, OR OTHERWISE USE OF THIS DOCUMENT IS STRICTLY PROHIBITED AND ANY INFRINGEMENT THEREUPON MAY BE SUBJECT TO LEGAL ACTION.

BOX EAVE RAFTER VERTICAL ROOF/SIDING OPTION

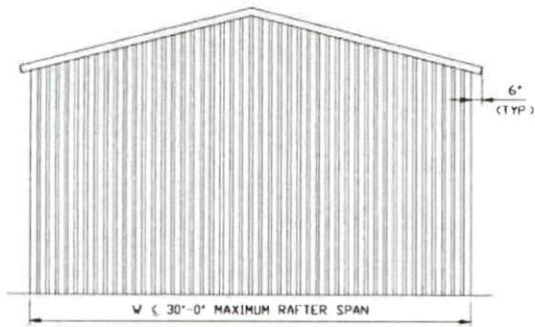

**TYPICAL END ELEVATION
VERTICAL ROOF/SIDING**
SCALE: NTS

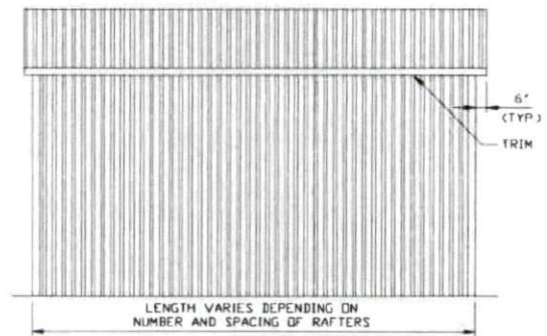

**TYPICAL SIDE ELEVATION
VERTICAL ROOF/SIDING**
SCALE: NTS

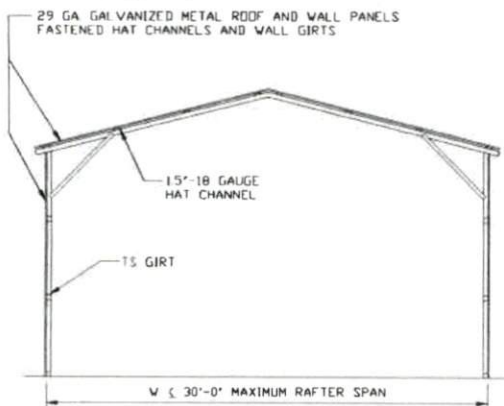

**TYPICAL SECTION VERTICAL
ROOF/SIDING OPTION**
SCALE: NTS

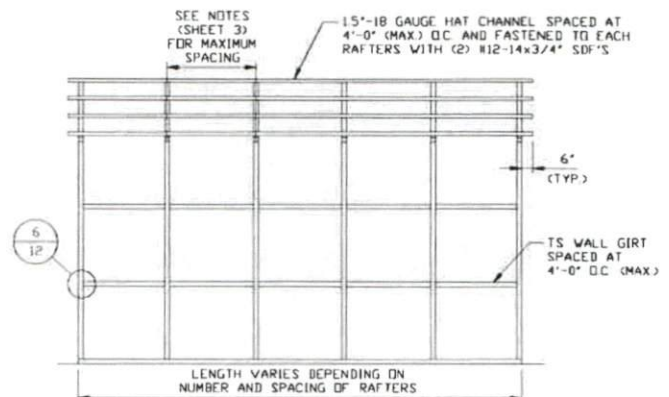

**TYPICAL FRAMING SECTION
VERTICAL ROOF/SIDING OPTION**
SCALE: NTS

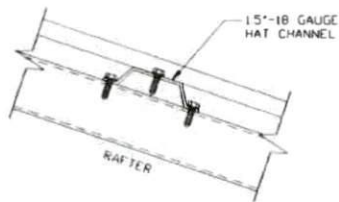

PANEL ATTACHMENT
(ALTERNATE FOR VERTICAL ROOF PANELS)
SCALE: NTS

**MOORE AND ASSOCIATES
ENGINEERING AND CONSULTING, INC.**

DRAWN BY: JG

CHECKED BY: PDH

PROJECT MGR: VSM

CLIENT: VEGA METAL

VEGA METAL STRUCTURES & CONCRETE, LLC.
4047 US HWY 311
RANDLEMAN, NC 27317
30'-0" x 20'-0" ENCLOSED STRUCTURE

DATE: 10-23-20

SHT. 16

SCALE: NTS

DWG. NO: SK-3

JOB NO: 20193S

REV: 0

THIS DOCUMENT IS THE PROPERTY OF MOORE AND ASSOCIATES ENGINEERING AND CONSULTING. THE UNAUTHORIZED REPRODUCTION, COPYING, OR OTHERWISE USE OF THIS DOCUMENT IS STRICTLY PROHIBITED AND ANY INFRINGEMENT THEREUPON MAY BE SUBJECT TO LEGAL ACTION.

SIDE WALL HEADER OPTIONS

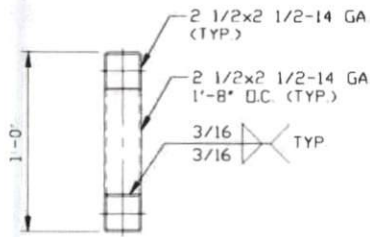

**HEADER DETAIL FOR DOOR OPENINGS
10'-0" < LENGTHS ≤ 16'-0"**

SCALE: NTS

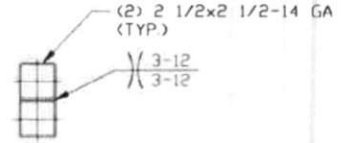

**HEADER DETAIL FOR DOOR OPENINGS
6'-0" < LENGTHS ≤ 10'-0"**

SCALE: NTS

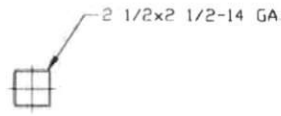

**HEADER DETAIL FOR DOOR OPENINGS
LENGTHS ≤ 6'-0"**

SCALE: NTS

END WALL HEADER OPTIONS

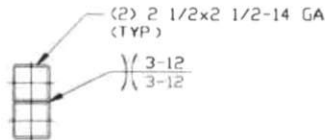

**HEADER DETAIL FOR DOOR OPENINGS
13'-0" < LENGTHS ≤ 16'-0"**

SCALE: NTS

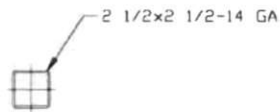

**HEADER DETAIL FOR DOOR OPENINGS
LENGTHS ≤ 13'-0"**

SCALE: NTS

**MOORE AND ASSOCIATES
ENGINEERING AND CONSULTING, INC.**

DRAWN BY: JG

CHECKED BY: PDH

PROJECT MGR: WSM

CLIENT: VEGA METAL

VEGA METAL STRUCTURES & CONCRETE, LLC.
4047 US HWY 311
RANDLEMAN, NC 27317
30'-0"x20'-0" ENCLOSED STRUCTURE

DATE: 10-23-20

SHT. 17

SCALE: NTS

DWG. NO SK-3

JOB NO: 20193S

REV: 0

THIS DOCUMENT IS THE PROPERTY OF MOORE AND ASSOCIATES ENGINEERING AND CONSULTING. THE UNAUTHORIZED REPRODUCTION, COPYING, OR OTHERWISE USE OF THIS DOCUMENT IS STRICTLY PROHIBITED AND ANY INFRINGEMENT THEREUPON MAY BE SUBJECT TO LEGAL ACTION.