

A PLUS CARPORTS

STRUCTURAL DESIGN

ENCLOSED BUILDING

**MAXIMUM 30'-0" WIDE X 20'- 0" EAVE HEIGHT-
BOX EAVE FRAME AND BOW FRAME**

11 November 2020

Revision 0

M&A Project No. 20209S

Prepared for:

A Plus Carports, LLC

4297 Hwy 268 East

Pilot Mountain, NC 27041

Prepared by:

Moore and Associates Engineering and Consulting, Inc.

1009 East Avenue

North Augusta, SC 29841

401 S. Main Street, Suite 200

Mount Airy, NC 27030



MOORE AND ASSOCIATES
ENGINEERING AND CONSULTING

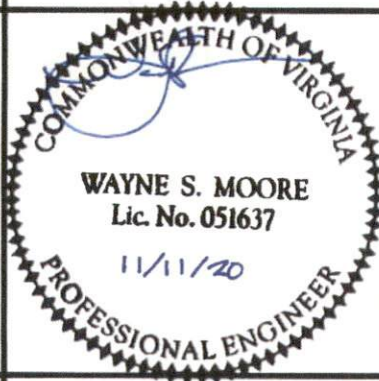
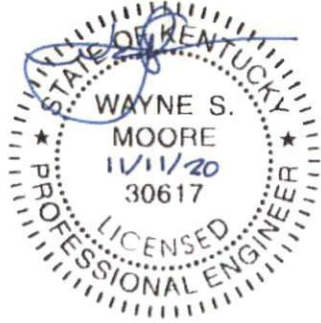

**MOORE AND ASSOCIATES
ENGINEERING AND CONSULTING, INC.**

DRAWN BY: LT		A PLUS CARPORTS, LLC 4297 HWY 268 EAST PILOT MOUNTAIN, NC 27041 30'-0"x20'-0" ENCLOSED STRUCTURE		
CHECKED BY: PDH				
PROJECT MGR: WSM	DATE: 11-11-20	SCALE: NTS	JOB NO: 20209S	
CLIENT: A PLUS	SHT. 1	DWG. NO: SK-3	REV: 0	

THIS DOCUMENT IS THE PROPERTY OF MOORE AND ASSOCIATES ENGINEERING AND CONSULTING. THE UNAUTHORIZED REPRODUCTION, COPYING, OR OTHERWISE USE OF THIS DOCUMENT IS STRICTLY PROHIBITED AND ANY INFRINGEMENT THEREUPON MAY BE SUBJECT TO LEGAL ACTION.

DRAWING INDEX

SHEET 1	PE SEAL COVER SHEET
SHEET 2	DRAWING INDEX
SHEET 3	INSTALLATION NOTES AND SPECIFICATIONS
SHEET 4	TYPICAL SIDE AND END ELEVATIONS
SHEET 5	TYPICAL RAFTER/COLUMN END AND SIDE FRAMING SECTION (BOX EAVE RAFTER)
SHEET 5A	TYPICAL RAFTER/COLUMN END AND SIDE FRAMING SECTION (BOX EAVE RAFTER)
SHEET 6	COLUMN CONNECTION DETAILS (BOX EAVE STRUCTURE)
SHEET 7	TYPICAL RAFTER/COLUMN END AND SIDE FRAMING SECTION (BOW EAVE RAFTER)
SHEET 7A	TYPICAL RAFTER/COLUMN END AND SIDE FRAMING SECTION (BOW EAVE RAFTER)
SHEET 8	COLUMN CONNECTION DETAILS (BOW EAVE RAFTER STRUCTURE)
SHEET 9	BASE RAIL ANCHORAGE OPTIONS
SHEET 10	BOX EAVE RAFTER END WALL AND SIDE WALL OPENINGS
SHEET 11	BOW EAVE RAFTER END WALL AND SIDE WALL OPENINGS
SHEET 12	CONNECTION DETAILS
SHEET 13	CONNECTION DETAILS
SHEET 14	LEAN-TO OPTIONS (BOX EAVE RAFTER)
SHEET 14A	LEAN-TO OPTIONS (BOX EAVE RAFTER)
SHEET 15	LEAN-TO OPTIONS (BOW EAVE RAFTER)
SHEET 16	BOX EAVE RAFTER VERTICAL ROOF/SIDING OPTION
SHEET 17	SIDE WALL AND END WALL HEADER OPTIONS

MOORE AND ASSOCIATES ENGINEERING AND CONSULTING, INC.	DRAWN BY: LT	A PLUS CARPORTS, LLC 4297 HWY 268 EAST PILOT MOUNTAIN, NC 27041 30'-0"x20'-0" ENCLOSED STRUCTURE		
	CHECKED BY: PDH			
THIS DOCUMENT IS THE PROPERTY OF MOORE AND ASSOCIATES ENGINEERING AND CONSULTING. THE UNAUTHORIZED REPRODUCTION, COPYING, OR OTHERWISE USE OF THIS DOCUMENT IS STRICTLY PROHIBITED AND ANY INFRINGEMENT THEREUPON MAY BE SUBJECT TO LEGAL ACTION.	PROJECT MGR: WSM	DATE: 11-11-20	SCALE: NTS	JOB NO: 20209S
	CLIENT: A PLUS	SHT. 2	DWG. NO: SK-3	REV: 0

INSTALLATION NOTES AND SPECIFICATIONS

1. DESIGN IS FOR MAXIMUM 30'-0" WIDE x 20'-0" EAVE HEIGHT ENCLOSED STRUCTURES
2. DESIGN WAS DONE IN ACCORDANCE WITH THE 2018 NORTH CAROLINA BUILDING CODE (NCBC), 2018 INTERNATIONAL BUILDING CODE (IBC), 2015 IBC AND 2012 IBC
3. DESIGN LOADS ARE AS FOLLOWS:
 - A) DEAD LOAD = 115 PSF
 - B) LIVE LOAD = 20 PSF
 - C) GROUND SNOW LOAD = 25 PSF

NOTE: UNBALANCED SNOW LOAD DUE TO DRIFTING HAS NOT BEEN EVALUATED
4. 3-SECOND GUST ULTIMATE WIND SPEED (V_{ULT}) = \leq 155 MPH (NOMINAL WIND SPEED = \leq 120 MPH)
5. MAXIMUM RAFTER/POST AND END POST SPACING = 40 FEET (UNLESS NOTED OTHERWISE).
6. END WALL COLUMNS (POSTS) ARE EQUIVALENT TO SIDE WALL POSTS IN SIZE AND SPACING (UNLESS NOTED OTHERWISE).
7. RISK CATEGORY I/II
8. WIND EXPOSURE CATEGORY B/C
9. SPECIFICATIONS APPLICABLE TO 29 GAUGE METAL PANELS FASTENED DIRECTLY TO 2 1/2" x 2 1/2" - 14 GAUGE TUBE STEEL (TS) FRAMING MEMBERS (UNLESS NOTED OTHERWISE), TS 2 1/4" x 2 1/4" - 12 GAUGE MAY BE USED AS OPTIONAL FRAMING MEMBERS
10. AVERAGE FASTENER SPACING ON-CENTERS ALONG RAFTERS OR HAT CHANNELS, AND COLUMNS (INTERIOR OR END) = 10" O.C. (MAX) FOR RC I AND 8" O.C. (MAX) FOR RC II.
11. FASTENERS CONSIST OF #12-14x3/4" SELF-DRILLING FASTENER (SDF), USE CONTROL SEAL WASHER WITH EXTERIOR FASTENERS. SPECIFICATIONS APPLICABLE ONLY FOR MEAN ROOF HEIGHT OF 20 FEET OR LESS, AND ROOF SLOPES OF 14" (3:12 PITCH) OR LESS. SPACING REQUIREMENTS FOR OTHER ROOF HEIGHTS AND/OR SLOPES MAY VARY. ROOF SLOPES LESS THAN 3:12 REQUIRE USE OF LAP JOINT SEALANT
12. ANCHORS SHALL BE INSTALLED THROUGH BASE RAIL WITHIN 6" OF EACH COLUMN.
13. STANDARD GROUND ANCHORS (SOIL NAILS) CONSIST OF #4 REBAR W/ WELDED NUT x 36" LONG AND MAY BE USED IN SUITABLE SOILS. OPTIONAL ANCHORAGE MAY BE USED IN SUITABLE SOILS AND MUST BE USED IN UNSUITABLE SOILS AS NOTED. SOIL NAILS MAY ONLY BE USED FOR WIND SPEEDS \leq 145 MPH. COORDINATE WITH LOCAL CODES/ORDINANCES REGARDING MINIMUM LENGTH FOR FROST DEPTH PROTECTION.
14. WIND FORCES GOVERN OVER SEISMIC FORCES. SEISMIC PARAMETERS ANALYZED ARE:
 SOIL SITE CLASS = D
 RISK CATEGORY I/II
 $R = 3.25$ $I_E = 10$
 $S_{05} = 2.039 g$ $V = C_S W$
 $S_{01} = 1.258 g$
15. MAXIMUM THRESHOLD HEIGHT FOR PERSONNEL DOORS USED FOR MEANS OF EGRESS IN RC II STRUCTURES IS 1/2"

**MOORE AND ASSOCIATES
ENGINEERING AND CONSULTING, INC.**

DRAWN BY: LT

CHECKED BY: PDH

PROJECT MGR: WSM

CLIENT: A PLUS

A PLUS CARPORTS, LLC
4297 HWY 268 EAST
PILOT MOUNTAIN, NC 27041
30-0"x20'-0" ENCLOSED STRUCTURE

DATE: 11-11-20

SCALE: NTS

JOB NO: 20209S

SHT. 3

DWG. NO: SK-3

REV: 0

THIS DOCUMENT IS THE PROPERTY OF MOORE AND ASSOCIATES ENGINEERING AND CONSULTING. THE UNAUTHORIZED REPRODUCTION, COPYING, OR OTHERWISE USE OF THIS DOCUMENT IS STRICTLY PROHIBITED AND ANY INFRINGEMENT THEREUPON MAY BE SUBJECT TO LEGAL ACTION.

BOX EAVE FRAME RAFTER STRUCTURE

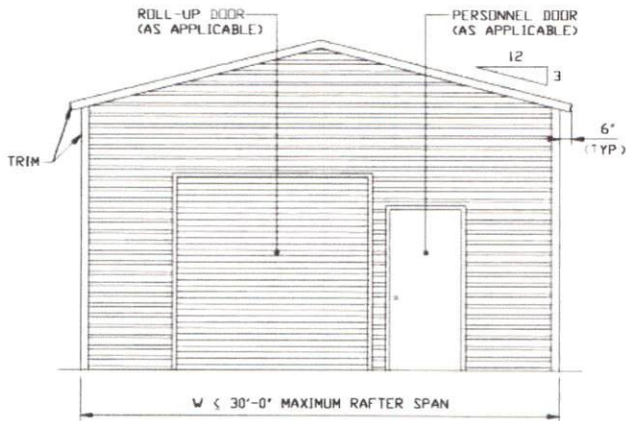

TYPICAL END ELEVATION

SCALE: NTS

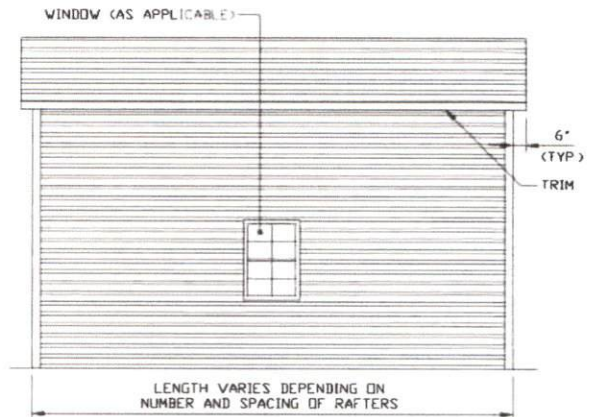

TYPICAL SIDE ELEVATION

SCALE: NTS

BOX EAVE FRAME RAFTER STRUCTURE

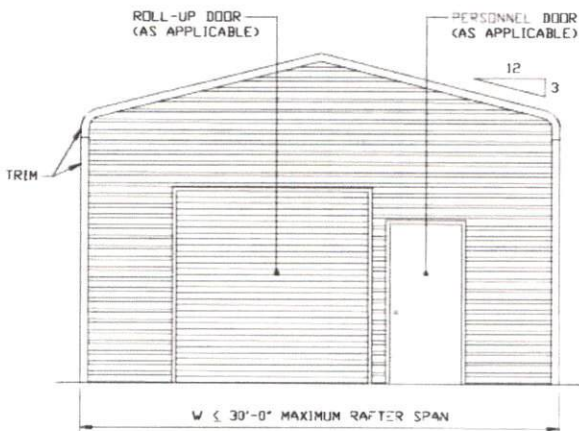

TYPICAL END ELEVATION

SCALE: NTS

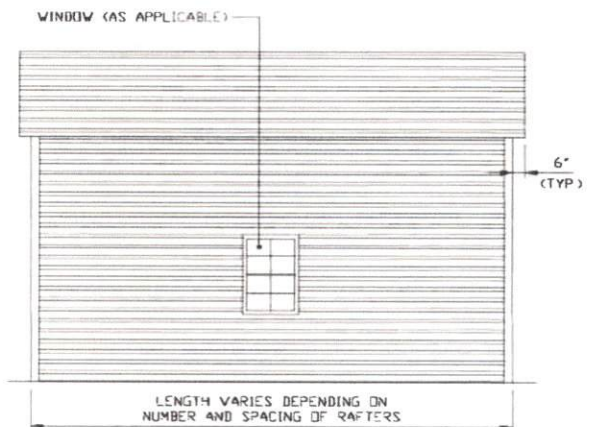

TYPICAL SIDE ELEVATION

SCALE: NTS

**MOORE AND ASSOCIATES
ENGINEERING AND CONSULTING, INC.**

DRAWN BY: LT

CHECKED BY: PDH

PROJECT MGR: WSM

CLIENT: A PLUS

A PLUS CARPORTS, LLC
4297 HWY 268 EAST
PILOT MOUNTAIN, NC 27041
30'-0" x 20'-0" ENCLOSED STRUCTURE

DATE: 11-11-20

SHT. 4

SCALE: NTS

DWG. NO: SK-3

JOB NO: 20209S

REV: 0

THIS DOCUMENT IS THE PROPERTY OF MOORE AND ASSOCIATES ENGINEERING AND CONSULTING. THE UNAUTHORIZED REPRODUCTION, COPYING, OR OTHERWISE USE OF THIS DOCUMENT IS STRICTLY PROHIBITED AND ANY INFRINGEMENT THEREUPON MAY BE SUBJECT TO LEGAL ACTION.

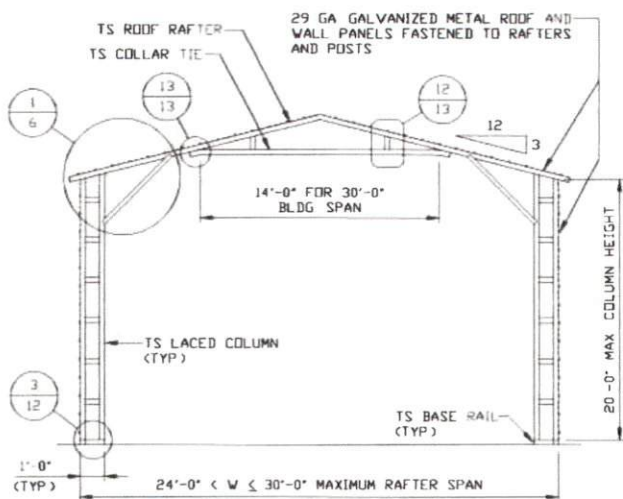

TYPICAL RAFTER/COLUMN END FRAME SECTION

SCALE: NTS

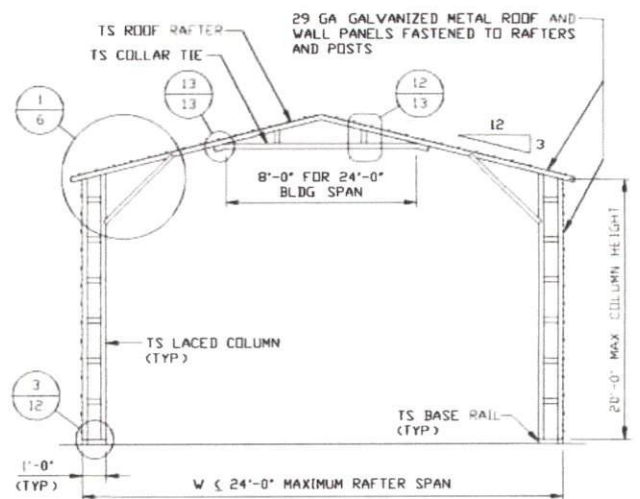

TYPICAL RAFTER/COLUMN END FRAME SECTION

SCALE: NTS

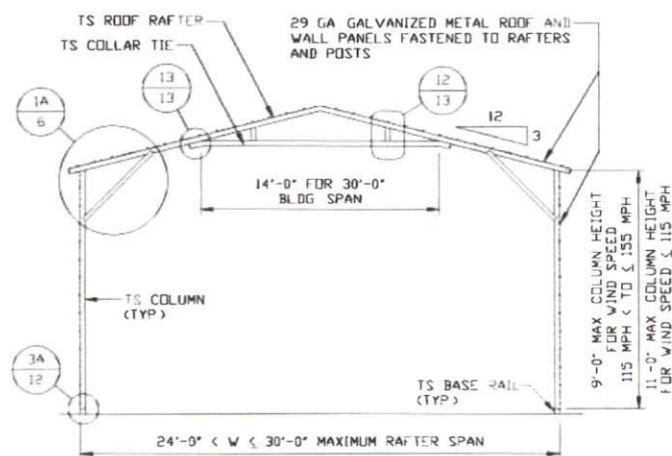

TYPICAL RAFTER/COLUMN END FRAME SECTION

SCALE: NTS

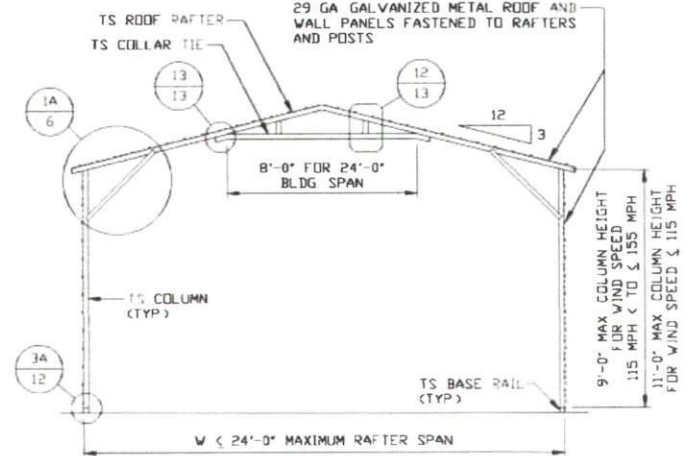

TYPICAL RAFTER/COLUMN END FRAME SECTION

SCALE: NTS

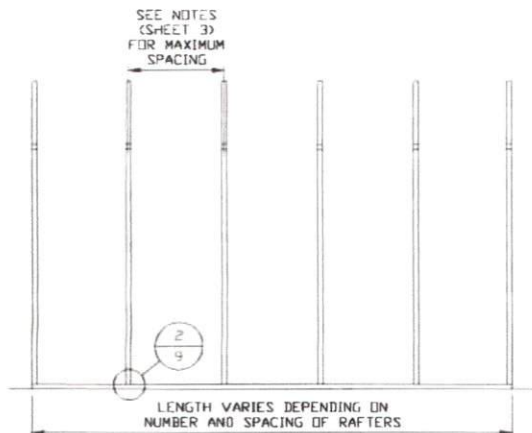

TYPICAL RAFTER/COLUMN SIDE FRAMING SECTION

SCALE: NTS

**MOORE AND ASSOCIATES
ENGINEERING AND CONSULTING, INC.**

DRAWN BY: LT

CHECKED BY: PDM

PROJECT MGR: VSM

CLIENT: A PLUS

A PLUS CARPORTS, LLC
4297 HWY 268 EAST
PILOT MOUNTAIN, NC 27041
30'-0" x 20'-0" ENCLOSED STRUCTURE

DATE: 11-11-20

SHT. 5

SCALE: NTS

DWG. NO: SK-3

JOB NO: 20209S

REV: 0

THIS DOCUMENT IS THE PROPERTY OF MOORE AND ASSOCIATES ENGINEERING AND CONSULTING. THE UNAUTHORIZED REPRODUCTION, COPYING, OR OTHERWISE USE OF THIS DOCUMENT IS STRICTLY PROHIBITED AND ANY INFRINGEMENT THEREUPON MAY BE SUBJECT TO LEGAL ACTION.

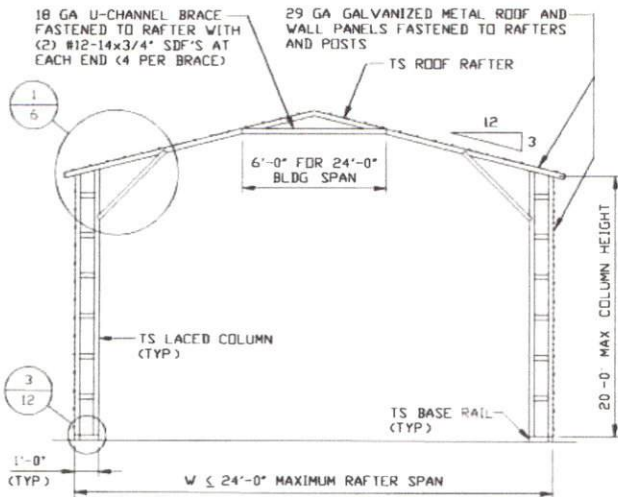

TYPICAL RAFTER/COLUMN END FRAME SECTION

SCALE: NTS

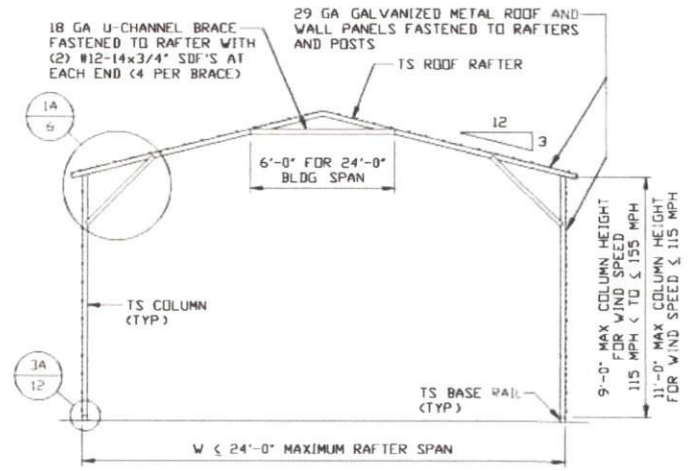

TYPICAL RAFTER/COLUMN END FRAME SECTION

SCALE: NTS

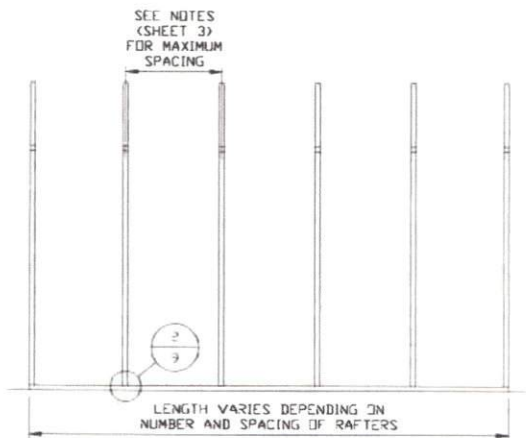

TYPICAL RAFTER/COLUMN SIDE FRAMING SECTION

SCALE: NTS

**MOORE AND ASSOCIATES
ENGINEERING AND CONSULTING, INC.**

DRAWN BY: LT
CHECKED BY: PDH

A PLUS CARPORTS, LLC
4297 HWY 268 EAST
PILOT MOUNTAIN, NC 27041
30'-0" x 20'-0" ENCLOSED STRUCTURE

THIS DOCUMENT IS THE PROPERTY OF MOORE AND ASSOCIATES ENGINEERING AND CONSULTING. THE UNAUTHORIZED REPRODUCTION, COPYING, OR OTHERWISE USE OF THIS DOCUMENT IS STRICTLY PROHIBITED AND ANY INFRINGEMENT THEREUPON MAY BE SUBJECT TO LEGAL ACTION.

PROJECT MGR: WSM
CLIENT: A PLUS

DATE: 11-11-20
SHT. 5A
SCALE: NTS
DWG. NO: SK-3
JOB NO: 202095
REV: 0

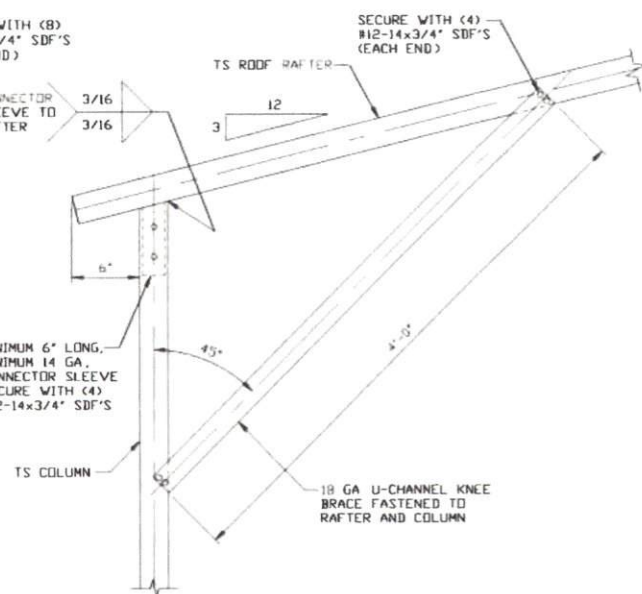
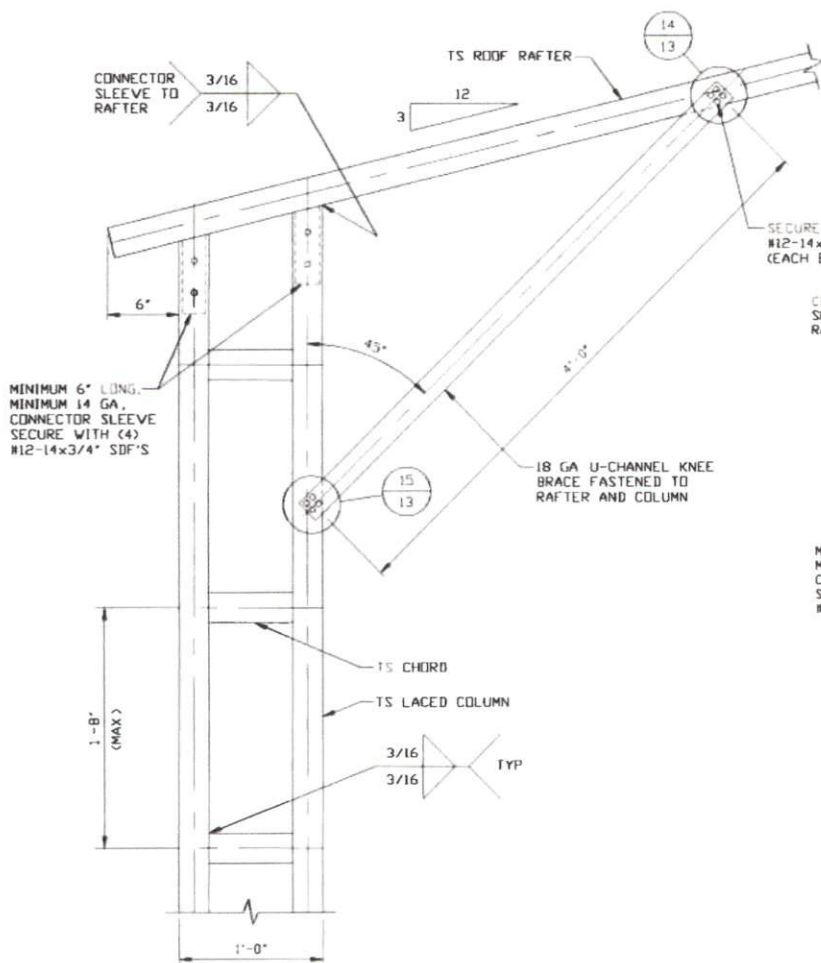

BOX EAVE RAFTER COLUMN CONNECTION DETAIL
 HEIGHTS $\leq 9'-0"$ FOR WIND SPEED 115 MPH $< TO \leq 155$ MPH
 HEIGHTS $\leq 11'-0"$ FOR WIND SPEED ≤ 115 MPH

1A
 SCALE: NTS
 NOTE: 3'-0" KNEE BRACE MAY BE USED FOR BUILDING WIDTH $\leq 24'-0"$

1
BOX EAVE RAFTER COLUMN CONNECTION DETAIL FOR HEIGHTS 9'-0" < TO <= 20'-0"
 SCALE: NTS

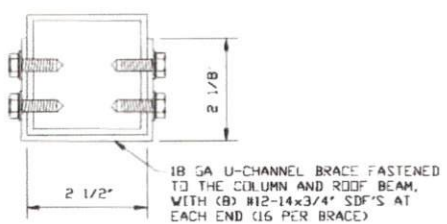

BRACE SECTION
 SCALE: NTS

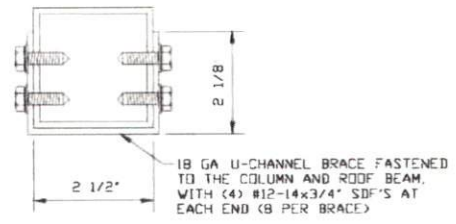

BRACE SECTION
 SCALE: NTS

MOORE AND ASSOCIATES ENGINEERING AND CONSULTING, INC.

DRAWN BY: LT
CHECKED BY: PDH

A PLUS CARPORTS, LLC
 4297 HWY 268 EAST
 PILOT MOUNTAIN, NC 27041
 30-0"x20'-0" ENCLOSED STRUCTURE

THIS DOCUMENT IS THE PROPERTY OF MOORE AND ASSOCIATES ENGINEERING AND CONSULTING. THE UNAUTHORIZED REPRODUCTION, COPYING, OR OTHERWISE USE OF THIS DOCUMENT IS STRICTLY PROHIBITED AND ANY INFRINGEMENT THEREUPON MAY BE SUBJECT TO LEGAL ACTION.

PROJECT MGR: VSM
CLIENT: A PLUS

DATE: 11-11-20
SHT. 6
SCALE: NTS
DWG. NO: SK-3
JOB NO: 20209S
REV: 0

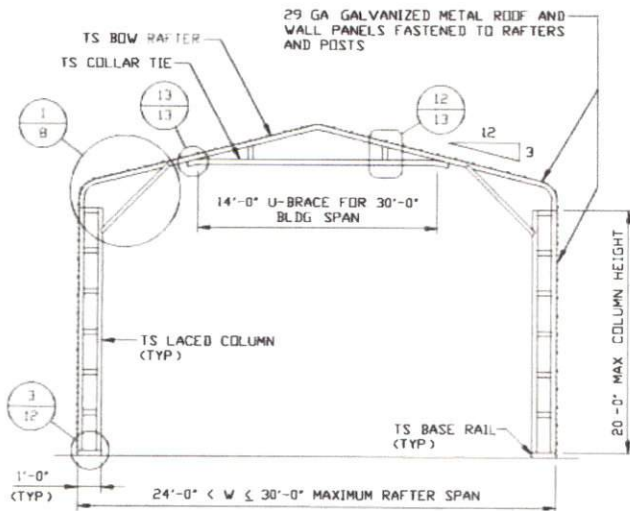

TYPICAL RAFTER/COLUMN END FRAME SECTION
SCALE: NTS

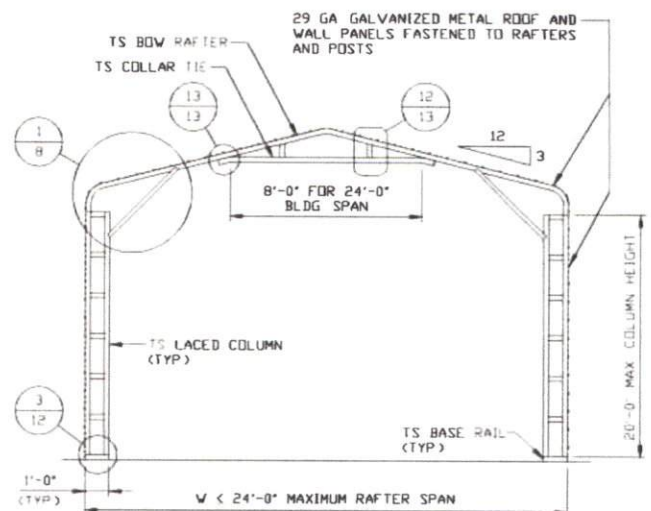

TYPICAL RAFTER/COLUMN END FRAME SECTION
SCALE: NTS

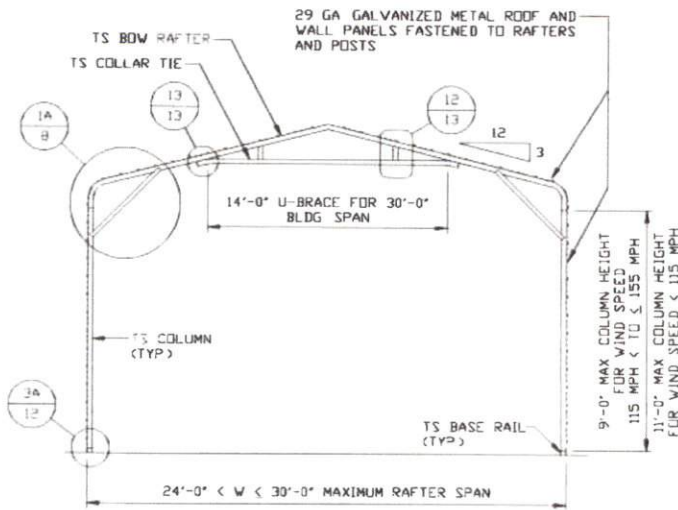

TYPICAL RAFTER/COLUMN END FRAME SECTION
SCALE: NTS

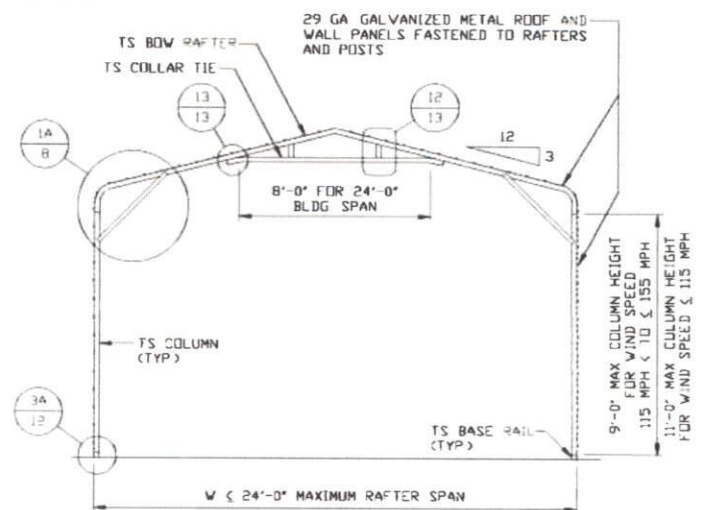

TYPICAL RAFTER/COLUMN END FRAME SECTION
SCALE: NTS

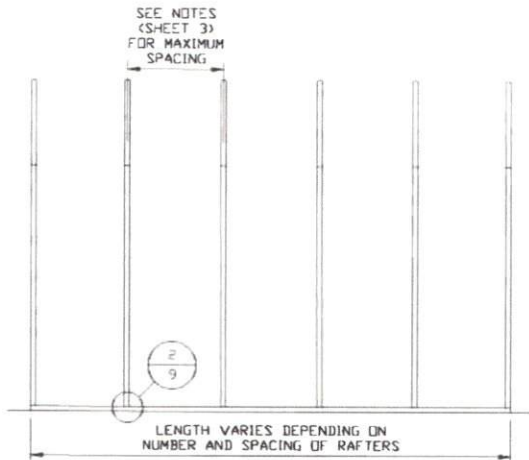

TYPICAL RAFTER/COLUMN FRAMING SIDE SECTION
SCALE: NTS

**MOORE AND ASSOCIATES
ENGINEERING AND CONSULTING, INC.**

DRAWN BY: LT

CHECKED BY: PDH

PROJECT MGR: WSM

CLIENT: A PLUS

A PLUS CARPORTS, LLC
4297 HWY 268 EAST
PILOT MOUNTAIN, NC 27041
30'-0"x20'-0" ENCLOSED STRUCTURE

DATE: 11-11-20

SHT. 7

SCALE: NTS

DWG. NO: SK-3

JOB NO: 20209S

REV.: 0

THIS DOCUMENT IS THE PROPERTY OF MOORE AND ASSOCIATES ENGINEERING AND CONSULTING. THE UNAUTHORIZED REPRODUCTION, COPYING, OR OTHERWISE USE OF THIS DOCUMENT IS STRICTLY PROHIBITED AND ANY INFRINGEMENT THEREUPON MAY BE SUBJECT TO LEGAL ACTION.

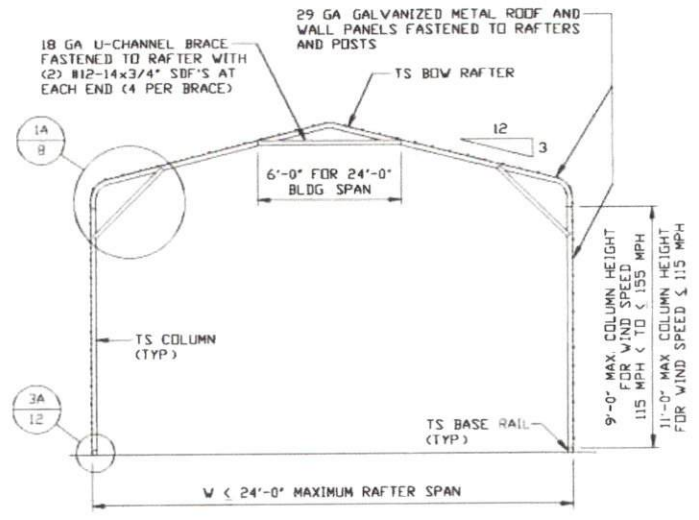
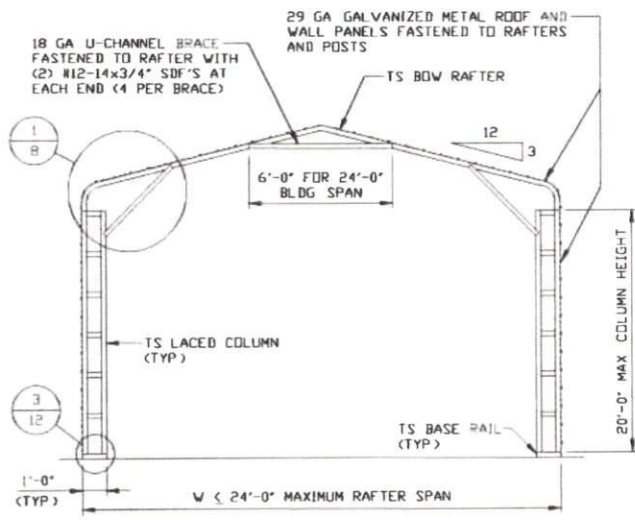

TYPICAL RAFTER/COLUMN END FRAME SECTION
SCALE: NTS

TYPICAL RAFTER/COLUMN END FRAME SECTION
SCALE: NTS

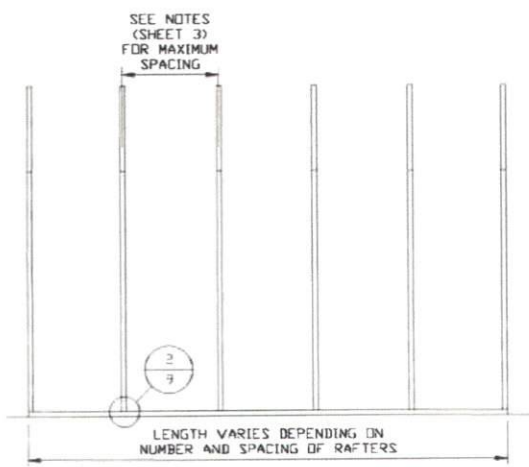

TYPICAL RAFTER/COLUMN FRAMING SIDE SECTION
SCALE: NTS

**MOORE AND ASSOCIATES
ENGINEERING AND CONSULTING, INC.**

DRAWN BY: LT		A PLUS CARPORTS, LLC 4297 HWY 268 EAST PILOT MOUNTAIN, NC 27041 30'-0"x20'-0" ENCLOSED STRUCTURE	
CHECKED BY: PDH		DATE: 11-11-20	SCALE: NTS
PROJECT MGR: WSM	DATE: 11-11-20	SCALE: NTS	JOB NO: 20209S
CLIENT: A PLUS	SHT. 7A	DWG. NO: SK-3	REV: 0

THIS DOCUMENT IS THE PROPERTY OF MOORE AND ASSOCIATES ENGINEERING AND CONSULTING. THE UNAUTHORIZED REPRODUCTION, COPYING, OR OTHERWISE USE OF THIS DOCUMENT IS STRICTLY PROHIBITED AND ANY INFRINGEMENT THEREUPON MAY BE SUBJECT TO LEGAL ACTION.

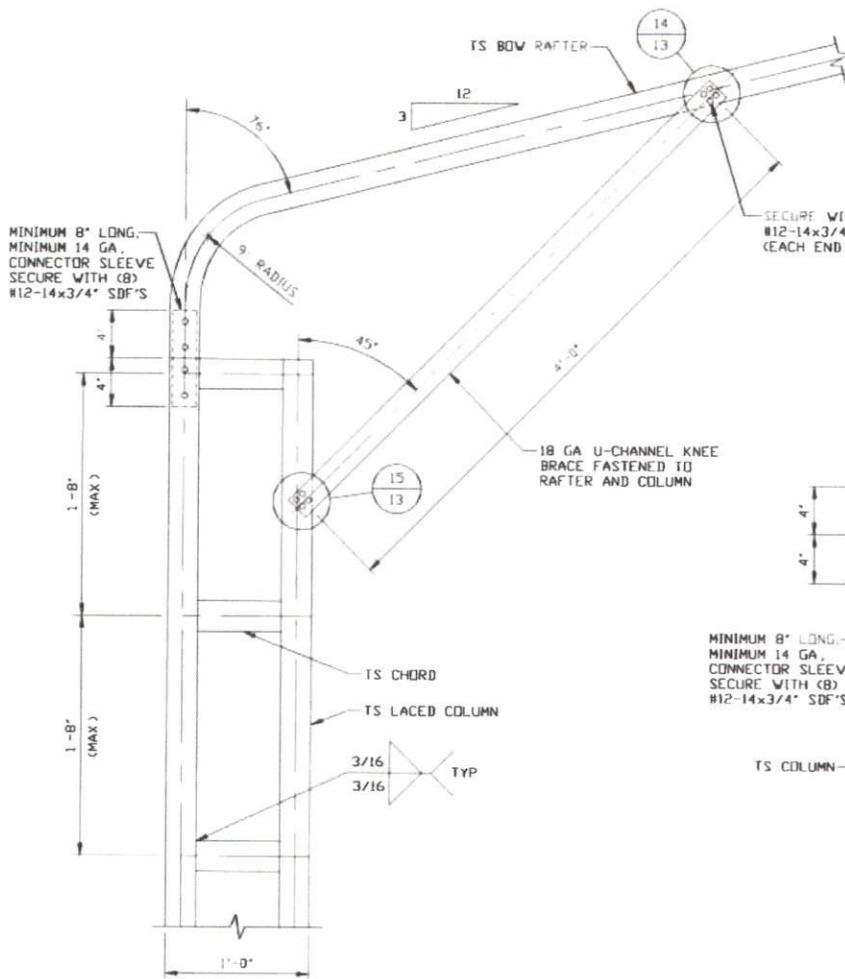

1

**BOW EAVE RAFTER COLUMN CONNECTION
DETAIL FOR HEIGHTS 9'-0" < TO ≤ 20'-0"**
SCALE: NTS

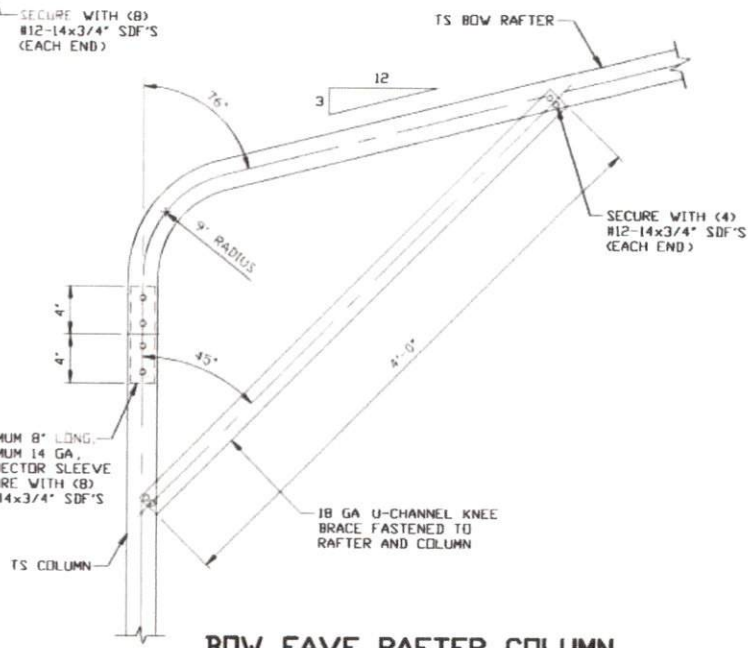

1A

**BOW EAVE RAFTER COLUMN
CONNECTION DETAIL
HEIGHTS ≤ 9'-0" FOR WIND SPEED
115 MPH < TO ≤ 155 MPH
HEIGHTS ≤ 11'-0" FOR
WIND SPEED < 115 MPH**
SCALE: NTS
NOTE: 3'-0" KNEE BRACE MAY BE USED
FOR BUILDING WIDTH ≤ 24'-0"

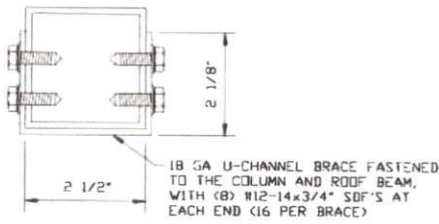

BRACE SECTION
SCALE: NTS

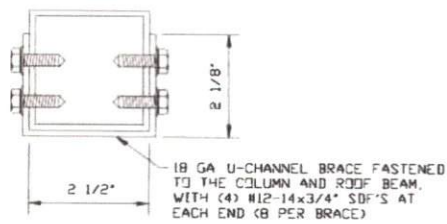

BRACE SECTION
SCALE: NTS

**MOORE AND ASSOCIATES
ENGINEERING AND CONSULTING, INC.**

DRAWN BY: LT
CHECKED BY: PDH

A PLUS CARPORTS, LLC
4297 HWY 268 EAST
PILOT MOUNTAIN, NC 27041
30-0"x20'-0" ENCLOSED STRUCTURE

THIS DOCUMENT IS THE PROPERTY OF MOORE AND ASSOCIATES ENGINEERING AND CONSULTING. THE UNAUTHORIZED REPRODUCTION, COPYING, OR OTHERWISE USE OF THIS DOCUMENT IS STRICTLY PROHIBITED AND ANY INFRINGEMENT THEREUPON MAY BE SUBJECT TO LEGAL ACTION.

PROJECT MGR: WSM
CLIENT: A PLUS

DATE: 11-11-20
SHT. 8

SCALE: NTS
DVG. NO: SK-3

JOB NO: 20209S
REV: 0

BASE RAIL ANCHORAGE OPTIONS

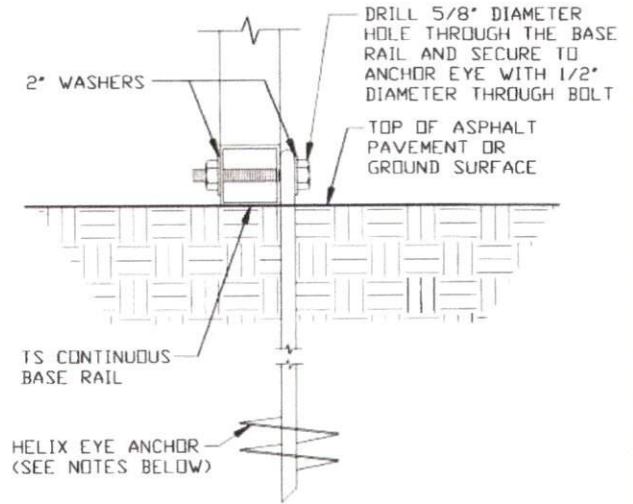
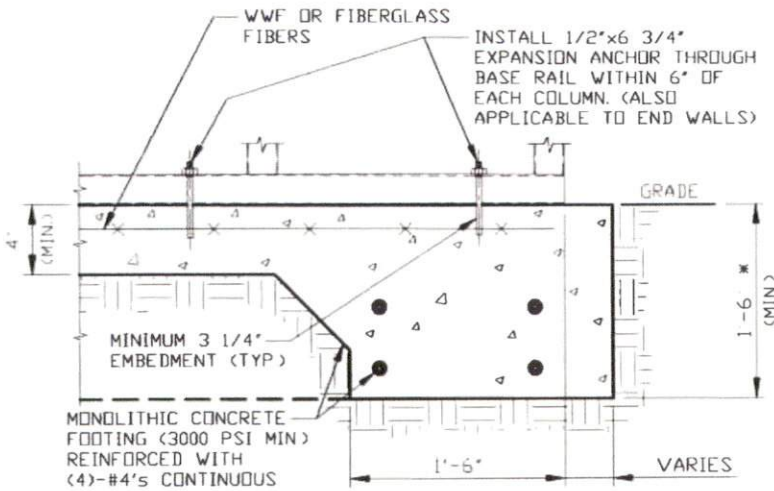

2

CONCRETE MONOLITHIC SLAB BASE RAIL ANCHORAGE

SCALE: NTS

MINIMUM ANCHOR EDGE DISTANCE IS 4"

* COORDINATE WITH LOCAL BUILDING CODE AND/OR BUILDING OFFICIAL REGARDING REQUIRED FOOTING DEPTH.

2A

GROUND BASE HELIX ANCHORAGE

SCALE: NTS

(CAN BE USED FOR ASPHALT)

* COORDINATE WITH LOCAL CODES/ORD REGARDING MIN. FROST DEPTH (LENGTH).

GENERAL NOTES

NOTE: CONCRETE MONOLITHIC SLAB DESIGN BASED ON MINIMUM SOIL BEARING CAPACITY OF 1,500 PSF.

CONCRETE:

CONCRETE SHALL HAVE A MINIMUM SPECIFIED COMPRESSIVE STRENGTH OF 3,000 PSI AT 28 DAYS

COVER OVER REINFORCING STEEL:

FOR FOUNDATIONS, MINIMUM CONCRETE COVER OVER REINFORCING BARS SHALL BE PER ACI-318:
3" IN FOUNDATIONS WHERE THE CONCRETE IS CAST AGAINST AND PERMANENTLY IN CONTACT WITH THE EARTH OR EXPOSED TO THE EARTH OR WEATHER, AND 1 1/2" ELSEWHERE

REINFORCING STEEL:

THE TURNDOWN REINFORCING STEEL SHALL BE ASTM A615 GRADE 50 THE SLAB REINFORCEMENT SHALL BE WELDED WIRE FABRIC MEETING ASTM A185 OR FIBERGLASS FIBER REINFORCEMENT

REINFORCEMENT MAY BE BENT IN THE SHOP OR THE FIELD PROVIDED:

- 1 REINFORCEMENT IS BENT COLD
- 2 THE DIAMETER OF THE BEND, MEASURED ON THE INSIDE OF THE BAR, IS NOT LESS THAN SIX-BAR DIAMETERS
- 3 REINFORCEMENT PARTIALLY EMBEDDED IN CONCRETE SHALL NOT BE FIELD BENT

HELIX ANCHOR NOTES:

- 1 FOR VERY DENSE AND/OR CEMENTED SANDS, COARSE GRAVEL AND COBBLES, CALICHE, PRELOADED SILTS AND CLAYS, USE MINIMUM (2) 4" HELICES WITH MINIMUM 30" EMBEDMENT OR SINGLE 6" HELIX WITH MINIMUM 50" EMBEDMENT
- 2 FOR CORAL USE MINIMUM (2) 4" HELICES WITH MINIMUM 30" EMBEDMENT OR SINGLE 6" HELIX WITH MINIMUM 50" EMBEDMENT
- 3 FOR MEDIUM DENSE COARSE SANDS, SANDY GRAVELS, VERY STIFF SILTS, AND CLAYS USE MINIMUM (2) 4" HELICES WITH MINIMUM 30 INCH EMBEDMENT OR SINGLE 6" HELIX WITH MINIMUM 50" EMBEDMENT
- 4 FOR LOOSE TO MEDIUM DENSE SANDS, FIRM TO STIFF CLAYS AND SILTS ALLUVIAL FILL, USE MINIMUM (2) 6" HELICES WITH MINIMUM 50" EMBEDMENT
- 5 FOR VERY LOSE TO MEDIUM DENSE SANDS, FIRM TO STIFFER CLAYS AND SILTS, ALLUVIAL FILL, USE MINIMUM (2) 8" HELICES WITH MINIMUM 60" EMBEDMENT.

**MOORE AND ASSOCIATES
ENGINEERING AND CONSULTING, INC.**

DRAWN BY: LT

CHECKED BY: PDH

PROJECT MGR: WSM

CLIENT: A PLUS

A PLUS CARPORTS, LLC
4297 HWY 268 EAST
PILOT MOUNTAIN, NC 27041
30-0"x20-0" ENCLOSED STRUCTURE

DATE: 11-11-20

SHT. 9

SCALE: NTS

DWG. NO: SK-3

JOB NO: 20209S

REV: 0

THIS DOCUMENT IS THE PROPERTY OF MOORE AND ASSOCIATES ENGINEERING AND CONSULTING. THE UNAUTHORIZED REPRODUCTION, COPYING, OR OTHERWISE USE OF THIS DOCUMENT IS STRICTLY PROHIBITED AND ANY INFRINGEMENT THEREUPON MAY BE SUBJECT TO LEGAL ACTION.

BOX EAVE RAFTER END WALL AND SIDE WALL OPENINGS

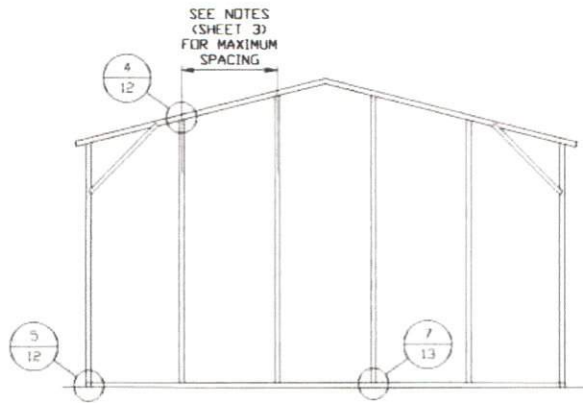

**TYPICAL BOX EAVE RAFTER
END WALL FRAMING SECTION**

SCALE: NTS

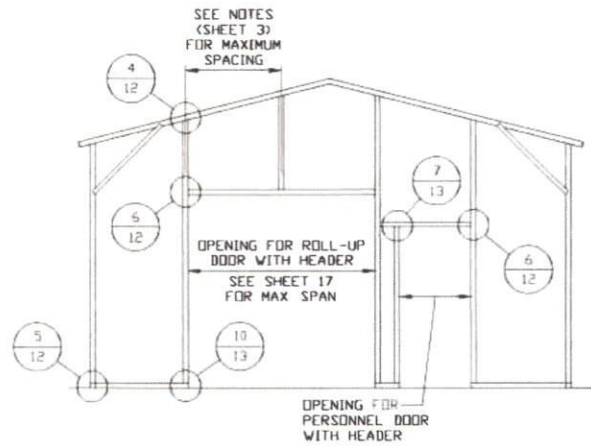

**TYPICAL BOX EAVE RAFTER END WALL
OPENINGS FRAMING SECTION**

SCALE: NTS

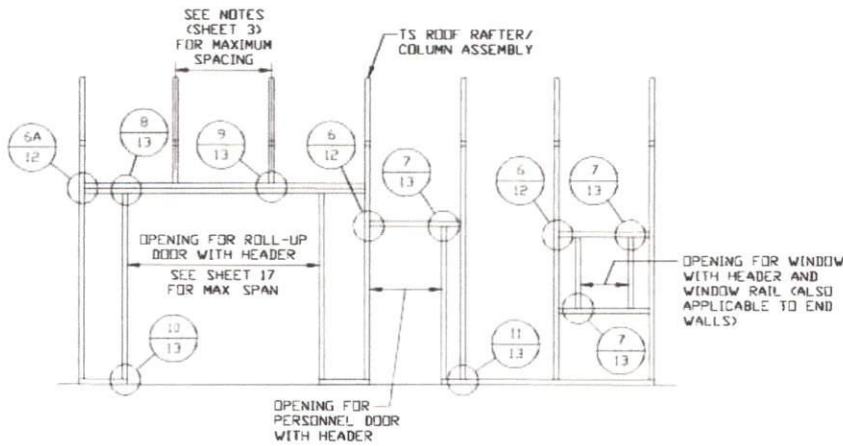

**TYPICAL BOX EAVE RAFTER SIDE
WALL OPENINGS FRAMING SECTION**

SCALE: NTS

**MOORE AND ASSOCIATES
ENGINEERING AND CONSULTING, INC.**

DRAWN BY: LT

CHECKED BY: PDH

PROJECT MGR: WSM

CLIENT: A PLUS

A PLUS CARPORTS, LLC
4297 HWY 268 EAST
PILOT MOUNTAIN, NC 27041
30'-0" x 20'-0" ENCLOSED STRUCTURE

DATE: 11-11-20

SCALE: NTS

JOB NO: 20209S

SHT. 10

DWG. NO: SK-3

REV. 0

THIS DOCUMENT IS THE PROPERTY OF MOORE AND ASSOCIATES ENGINEERING AND CONSULTING. THE UNAUTHORIZED REPRODUCTION, COPYING, OR OTHERWISE USE OF THIS DOCUMENT IS STRICTLY PROHIBITED AND ANY INFRINGEMENT THEREUPON MAY BE SUBJECT TO LEGAL ACTION.

BOW RAFTER END WALL AND SIDE WALL OPENINGS

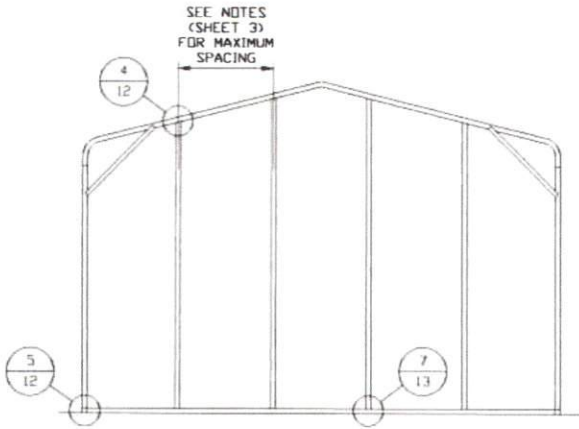

**TYPICAL BOW RAFTER
END WALL FRAMING SECTION**

SCALE: NTS

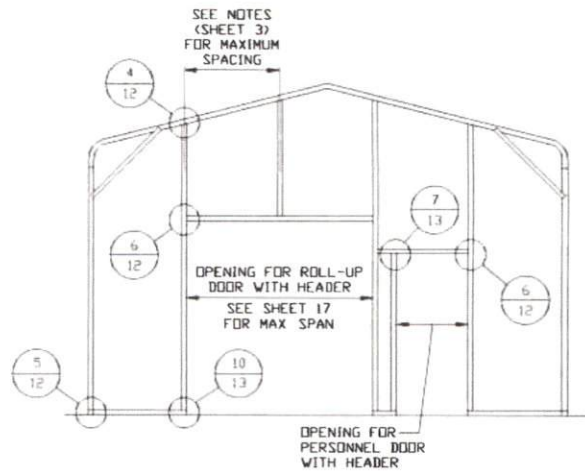

**TYPICAL BOW RAFTER END WALL
OPENINGS FRAMING SECTION**

SCALE: NTS

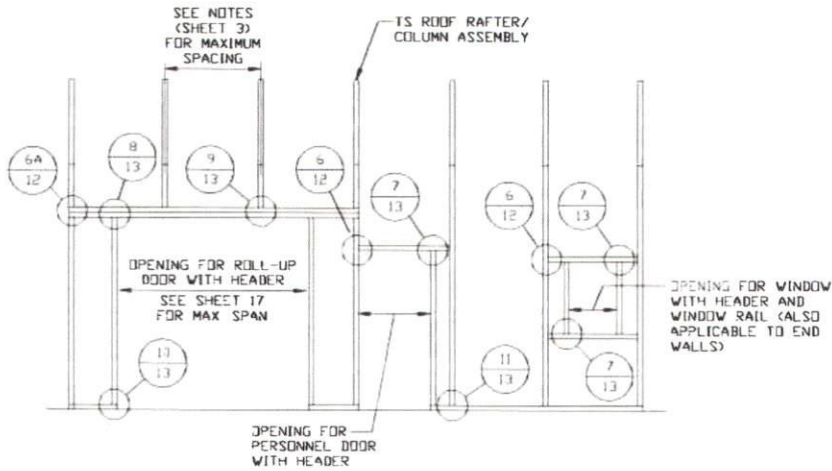

**TYPICAL BOW RAFTER SIDE
WALL OPENINGS FRAMING SECTION**

SCALE: NTS

**MOORE AND ASSOCIATES
ENGINEERING AND CONSULTING, INC.**

DRAWN BY: LT

CHECKED BY: PDH

PROJECT MGR: WSM

CLIENT: A PLUS

A PLUS CARPORTS, LLC
4297 HWY 268 EAST
PILOT MOUNTAIN, NC 27041
30'-0" x 20'-0" ENCLOSED STRUCTURE

DATE: 11-11-20

SHT. 11

SCALE: NTS

DWG. NO: SK-3

JOB NO: 20209S

REV: 0

THIS DOCUMENT IS THE PROPERTY OF MOORE AND ASSOCIATES ENGINEERING AND CONSULTING. THE UNAUTHORIZED REPRODUCTION, COPYING, OR OTHERWISE USE OF THIS DOCUMENT IS STRICTLY PROHIBITED AND ANY INFRINGEMENT THEREUPON MAY BE SUBJECT TO LEGAL ACTION.

CONNECTION DETAILS

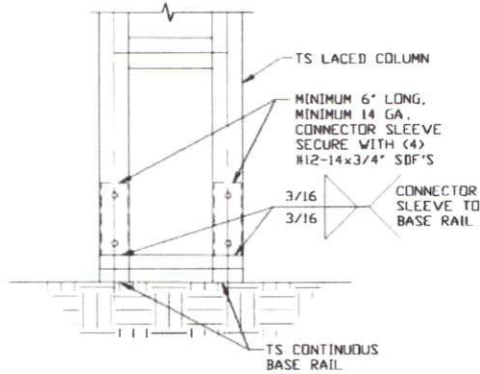

3 RAFTER COLUMN/BASE RAIL CONNECTION DETAIL

SCALE: NTS

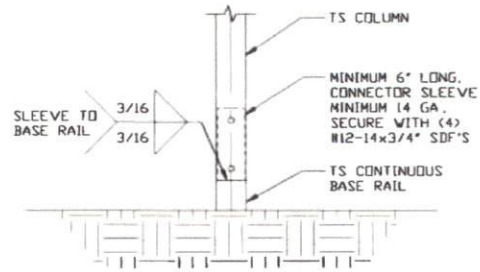

3A RAFTER COLUMN/BASE RAIL CONNECTION DETAIL

SCALE: NTS

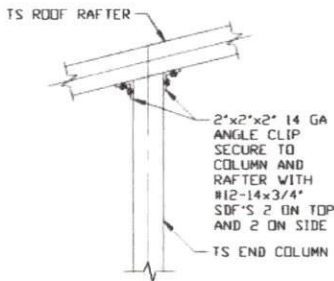

4 END COLUMN/RAFTER CONNECTION DETAIL

SCALE: NTS

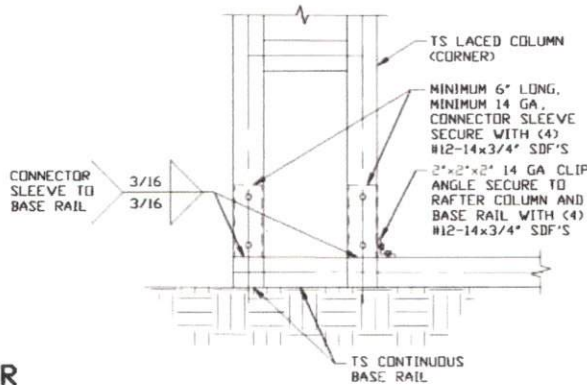

5 END COLUMN/BASE RAIL CONNECTION DETAIL

SCALE: NTS

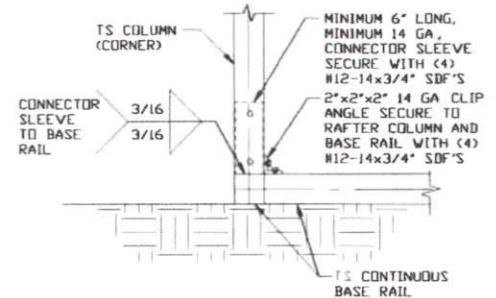

5A END COLUMN/BASE RAIL CONNECTION DETAIL

SCALE: NTS

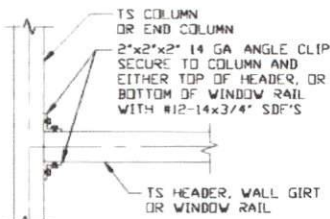

6 COLUMN OR WINDOW RAIL/WALL GIRT TO POST CONNECTION DETAIL

SCALE: NTS

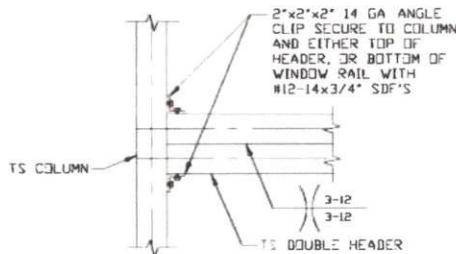

6A COLUMN OR DOUBLE HEADER TO POST CONNECTION DETAIL

SCALE: NTS

**MOORE AND ASSOCIATES
ENGINEERING AND CONSULTING, INC.**

DRAWN BY: LT

CHECKED BY: PDH

PROJECT MGR: WSM

CLIENT: A PLUS

A PLUS CARPORTS, LLC
4297 HWY 268 EAST
PILOT MOUNTAIN, NC 27041
30'-0" x 20'-0" ENCLOSED STRUCTURE

DATE: 11-11-20

SHT. 12

SCALE: NTS

DWG. NO: SK-3

JOB NO: 20209S

REV: 0

THIS DOCUMENT IS THE PROPERTY OF MOORE AND ASSOCIATES ENGINEERING AND CONSULTING. THE UNAUTHORIZED REPRODUCTION, COPYING, OR OTHERWISE USE OF THIS DOCUMENT IS STRICTLY PROHIBITED AND ANY INFRINGEMENT THEREUPON MAY BE SUBJECT TO LEGAL ACTION.

CONNECTION DETAILS

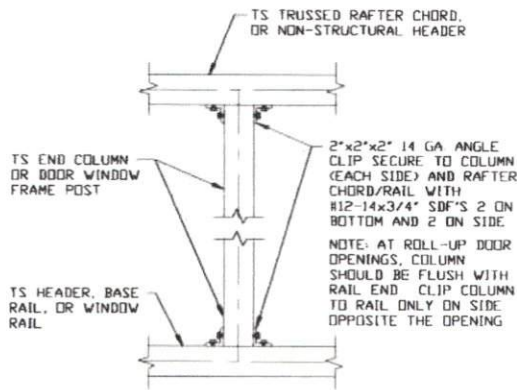

7 COLUMN TO WINDOW RAIL CONNECTION DETAIL
SCALE: NTS

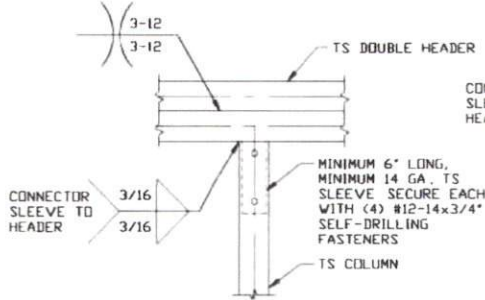

8 DOUBLE HEADER/COLUMN CONNECTION DETAIL
SCALE: NTS

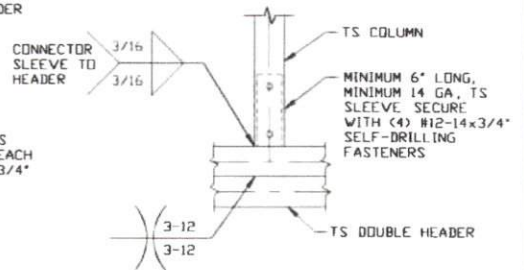

9 COLUMN/DOUBLE HEADER CONNECTION DETAIL
SCALE: NTS

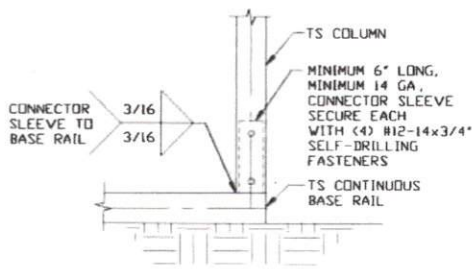

10 COLUMN/BASE RAIL CONNECTION DETAIL
SCALE: NTS

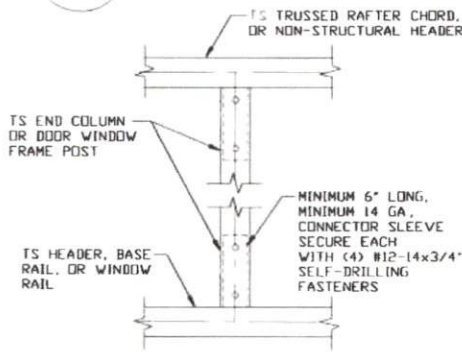

11 COLUMN TO HEADER OR BASE RAIL CONNECTION DETAIL
SCALE: NTS

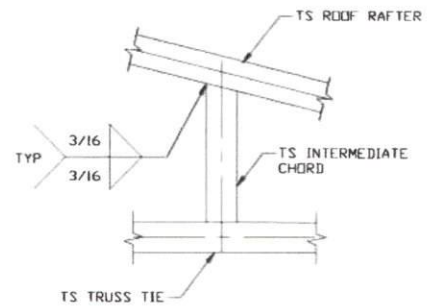

12 RAFTER TO CHORD CONNECTION DETAIL
SCALE: NTS

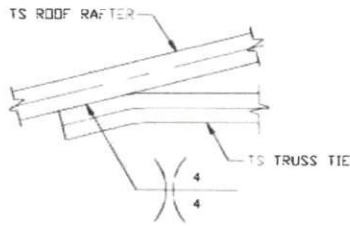

13 COLLAR TIE CONNECTION DETAIL
SCALE: NTS

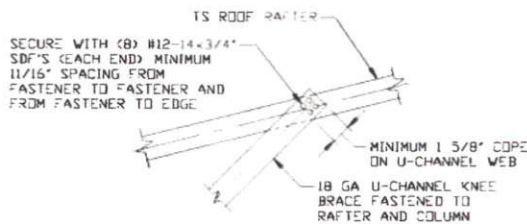

14 U-CHANNEL TO RAFTER CONNECTION DETAIL
SCALE: NTS

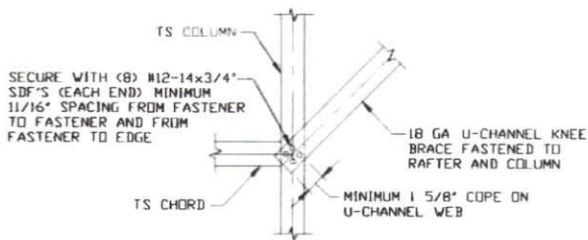

15 U-CHANNEL TO COLUMN CONNECTION DETAIL
SCALE: NTS

**MOORE AND ASSOCIATES
ENGINEERING AND CONSULTING, INC.**

DRAWN BY: LT

CHECKED BY: PDH

PROJECT MGR: WSM

CLIENT: A PLUS

A PLUS CARPORTS, LLC
4297 HWY 268 EAST
PILOT MOUNTAIN, NC 27041
30'-0" x 20'-0" ENCLOSED STRUCTURE

DATE: 11-11-20

SHT. 13

SCALE: NTS

DWG. NO: SK-3

JOB NO: 20209S

REV: 0

THIS DOCUMENT IS THE PROPERTY OF MOORE AND ASSOCIATES ENGINEERING AND CONSULTING. THE UNAUTHORIZED REPRODUCTION, COPYING, OR OTHERWISE USE OF THIS DOCUMENT IS STRICTLY PROHIBITED AND ANY INFRINGEMENT THEREUPON MAY BE SUBJECT TO LEGAL ACTION.

BOX EAVE RAFTER LEAN-TO OPTIONS

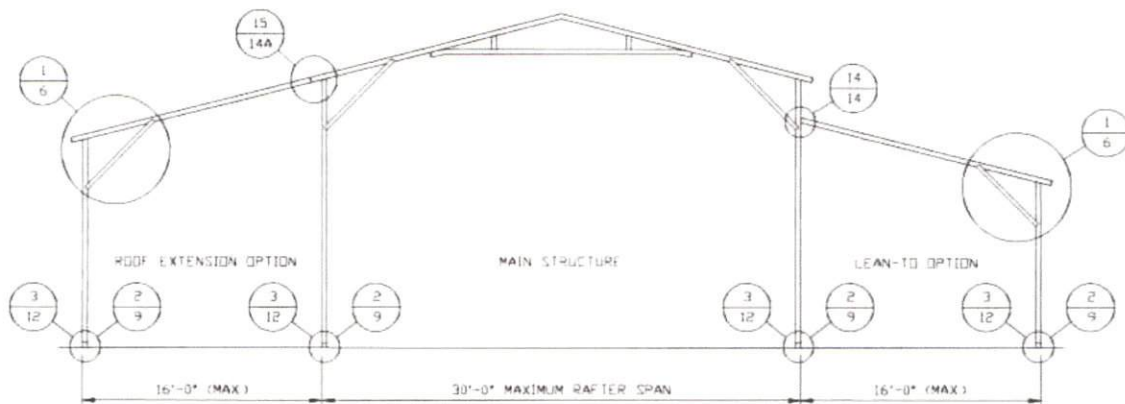

TYPICAL BOX EAVE RAFTER LEAN-TO OPTIONS FRAMING SECTION (BOTH OPTIONS SHOWN)

SCALE: NTS

MAXIMUM WIDTH OF LACED TUBE MEMBER (RAFTER AND COLUMN) ROOF EXTENSION AND LEAN-TO IS 16'-0"

MAXIMUM WIDTH OF SINGLE TUBE MEMBER (RAFTER AND COLUMN) ROOF EXTENSION AND LEAN-TO IS 11'-0"

REFERENCE RAFTER COLUMN CONNECTION DETAILS FOR APPROPRIATE COLUMN HEIGHT AND TUBING SPECIFICATION

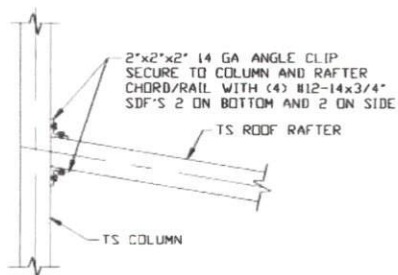

LEAN-TO RAFTER TO RAFTER COLUMN CONNECTION DETAIL FOR RAFTER SPANS $\leq 11'-0"$

14

SCALE: NTS

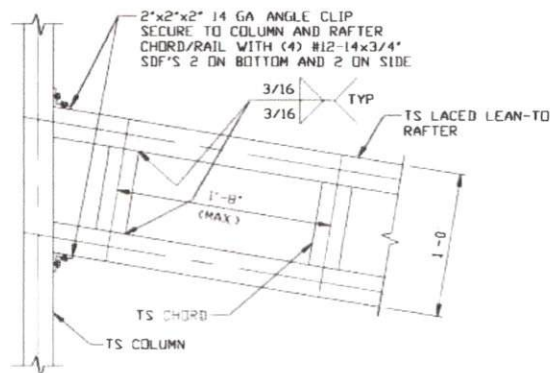

LEAN-TO RAFTER TO RAFTER COLUMN CONNECTION DETAIL FOR RAFTER SPANS $11'-0" < \text{TO} \leq 16'-0"$

14A

SCALE: NTS

**MOORE AND ASSOCIATES
ENGINEERING AND CONSULTING, INC.**

DRAWN BY: LT

CHECKED BY: PDH

PROJECT MGR: WSM

CLIENT: A PLUS

A PLUS CARPORTS, LLC
4297 HWY 268 EAST
PILOT MOUNTAIN, NC 27041
30'-0" x 20'-0" ENCLOSED STRUCTURE

DATE: 11-11-20

SHT. 14

SCALE: NTS

DWG. NO: SK-3

JOB NO: 20209S

REV: 0

THIS DOCUMENT IS THE PROPERTY OF MOORE AND ASSOCIATES ENGINEERING AND CONSULTING. THE UNAUTHORIZED REPRODUCTION, COPYING, OR OTHERWISE USE OF THIS DOCUMENT IS STRICTLY PROHIBITED AND ANY INFRINGEMENT THEREUPON MAY BE SUBJECT TO LEGAL ACTION.

BOX EAVE RAFTER LEAN-TO OPTIONS

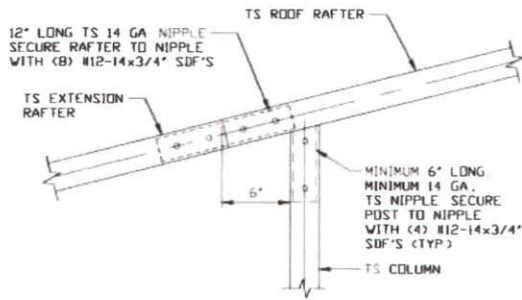

15 SIDE EXTENSION RAFTER
COLUMN DETAIL FOR
RAFTER SPANS $\leq 11'-0''$

SCALE: NTS

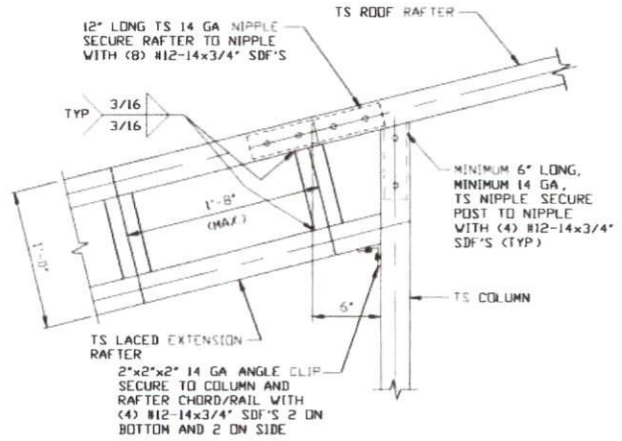

15A SIDE EXTENSION RAFTER
COLUMN DETAIL FOR
SPANS $11'-0'' < TO \leq 16'-0''$

SCALE: NTS

**MOORE AND ASSOCIATES
ENGINEERING AND CONSULTING, INC.**

DRAWN BY: LT

CHECKED BY: PDH

PROJECT MGR: WSM

CLIENT: A PLUS

**A PLUS CARPORTS, LLC
4297 HWY 268 EAST
PILOT MOUNTAIN, NC 27041
30'-0"x20'-0" ENCLOSED STRUCTURE**

DATE: 11-11-20

SHT. 14A

SCALE: NTS

DWG. NO: SK-3

JOB NO: 20209S

REV: 0

THIS DOCUMENT IS THE PROPERTY OF MOORE AND ASSOCIATES ENGINEERING AND CONSULTING. THE UNAUTHORIZED REPRODUCTION, COPYING, OR OTHERWISE USE OF THIS DOCUMENT IS STRICTLY PROHIBITED AND ANY INFRINGEMENT THEREUPON MAY BE SUBJECT TO LEGAL ACTION.

BOW EAVE RAFTER LEAN-TO OPTION

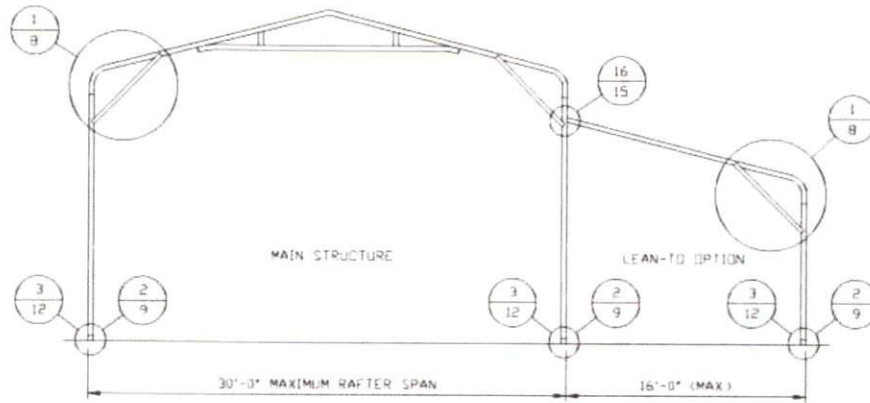

TYPICAL BOW EAVE RAFTER LEAN-TO OPTION FRAMING SECTION

SCALE: NTS

MAXIMUM WIDTH OF LACED TUBE MEMBER (RAFTER AND COLUMN) ROOF EXTENSION AND LEAN-TO IS 16'-0"
 MAXIMUM WIDTH OF SINGLE TUBE MEMBER (RAFTER AND COLUMN) ROOF EXTENSION AND LEAN-TO IS 11'-0".
 REFERENCE RAFTER COLUMN CONNECTION DETAILS FOR APPROPRIATE COLUMN HEIGHT AND TUBING SPECIFICATION

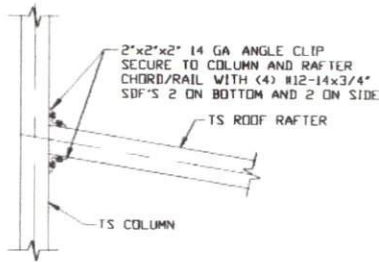

LEAN-TO RAFTER TO RAFTER COLUMN CONNECTION DETAIL FOR RAFTER SPANS $\leq 11'-0''$

16

SCALE: NTS

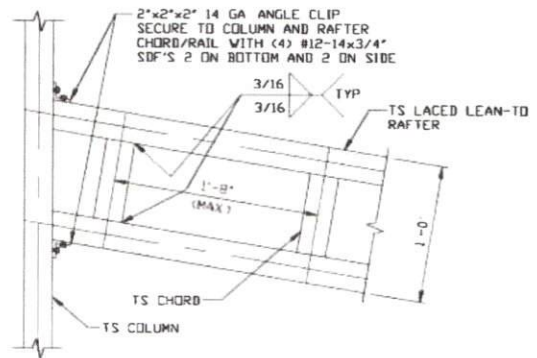

LEAN-TO RAFTER TO RAFTER COLUMN CONNECTION DETAIL FOR RAFTER SPANS $11'-0'' < TD \leq 16'-0''$

16A

SCALE: NTS

**MOORE AND ASSOCIATES
ENGINEERING AND CONSULTING, INC.**

DRAWN BY: LT

CHECKED BY: PDH

PROJECT MGR: WSH

CLIENT: A PLUS

A PLUS CARPORTS, LLC
 4297 HWY 268 EAST
 PILOT MOUNTAIN, NC 27041
 30'-0"X20'-0" ENCLOSED STRUCTURE

DATE: 11-11-20

SHT. 15

SCALE: NTS

DWG. NO: SK-3

JOB NO: 20209S

REV: 0

THIS DOCUMENT IS THE PROPERTY OF MOORE AND ASSOCIATES ENGINEERING AND CONSULTING. THE UNAUTHORIZED REPRODUCTION, COPYING, OR OTHERWISE USE OF THIS DOCUMENT IS STRICTLY PROHIBITED AND ANY INFRINGEMENT THEREUPON MAY BE SUBJECT TO LEGAL ACTION.

BOX EAVE RAFTER VERTICAL ROOF/SIDING OPTION

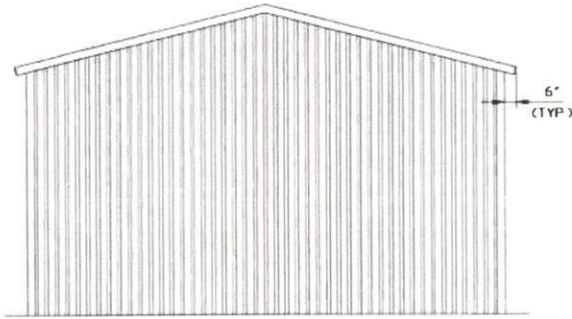

**TYPICAL END ELEVATION
VERTICAL ROOF/SIDING**

SCALE: NTS

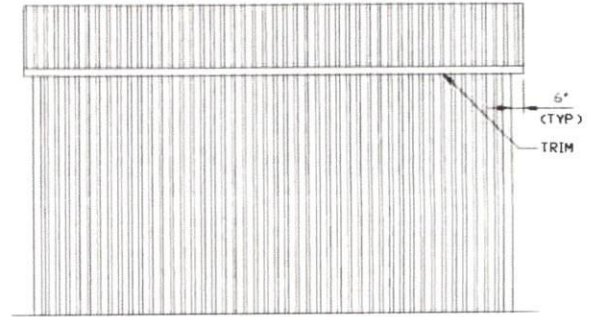

**TYPICAL SIDE ELEVATION
VERTICAL ROOF/SIDING**

SCALE: NTS

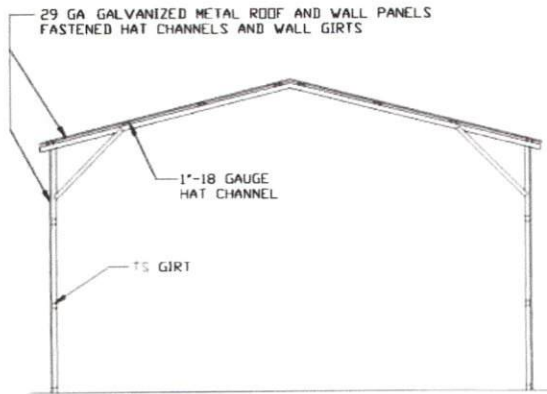

**TYPICAL SECTION VERTICAL
ROOF/SIDING OPTION**

SCALE: NTS

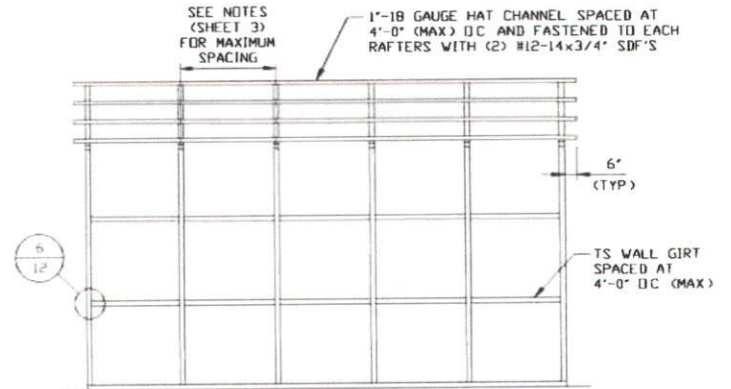

**TYPICAL FRAMING SECTION
VERTICAL ROOF/SIDING OPTION**

SCALE: NTS

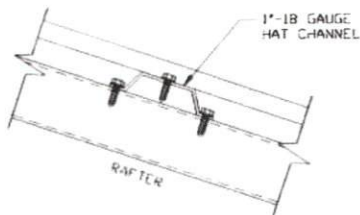

PANEL ATTACHMENT

(ALTERNATE FOR VERTICAL ROOF PANELS)

SCALE: NTS

**MOORE AND ASSOCIATES
ENGINEERING AND CONSULTING, INC.**

DRAWN BY: LT

CHECKED BY: PDH

PROJECT MGR: WSM

CLIENT: A PLUS

A PLUS CARPORTS, LLC
4297 HWY 268 EAST
PILOT MOUNTAIN, NC 27041
30'-0" x 20'-0" ENCLOSED STRUCTURE

DATE: 11-11-20

SCALE: NTS

JOB NO: 20209S

SHT. 16

DWG. NO: SK-3

REV: 0

THIS DOCUMENT IS THE PROPERTY OF MOORE AND ASSOCIATES ENGINEERING AND CONSULTING. THE UNAUTHORIZED REPRODUCTION, COPYING, OR OTHERWISE USE OF THIS DOCUMENT IS STRICTLY PROHIBITED AND ANY INFRINGEMENT THEREUPON MAY BE SUBJECT TO LEGAL ACTION.

SIDE WALL HEADER OPTIONS

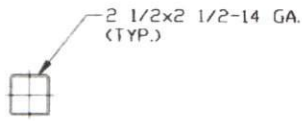

HEADER DETAIL FOR DOOR OPENINGS LENGTHS $\leq 6'-0"$

SCALE: NTS

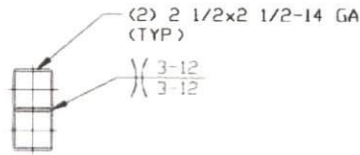

HEADER DETAIL FOR DOOR OPENINGS $6'-0" < \text{LENGTHS} \leq 10'-0"$

SCALE: NTS

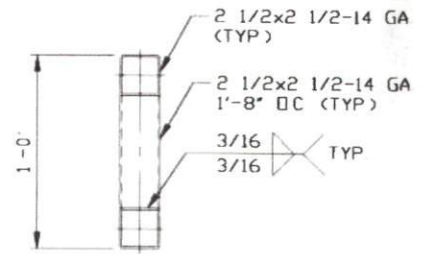

HEADER DETAIL FOR DOOR OPENINGS $10'-0" < \text{LENGTHS} \leq 20'-0"$

SCALE: NTS

END WALL HEADER OPTIONS

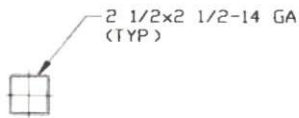

HEADER DETAIL FOR DOOR OPENINGS LENGTHS $\leq 7'-0"$

SCALE: NTS

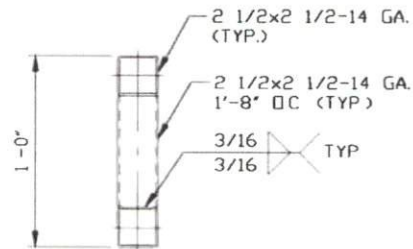

HEADER DETAIL FOR DOOR OPENINGS $7'-0" < \text{LENGTHS} \leq 20'-0"$

SCALE: NTS

**MOORE AND ASSOCIATES
ENGINEERING AND CONSULTING, INC.**

DRAWN BY: LT

CHECKED BY: PDH

PROJECT MGR: WSM

CLIENT: A PLUS

A PLUS CARPORTS, LLC
4297 HWY 268 EAST
PILOT MOUNTAIN, NC 27041
30'-0"x20'-0" ENCLOSED STRUCTURE

DATE: 11-11-20

SHT. 17

SCALE: NTS

DWG. NO: SK-3

JOB NO: 20209S

REV: 0

THIS DOCUMENT IS THE PROPERTY OF MOORE AND ASSOCIATES ENGINEERING AND CONSULTING. THE UNAUTHORIZED REPRODUCTION, COPYING, OR OTHERWISE USE OF THIS DOCUMENT IS STRICTLY PROHIBITED AND ANY INFRINGEMENT THEREUPON MAY BE SUBJECT TO LEGAL ACTION.