

NOTICE TO CONTRACTOR
All construction must comply with current NC Building Codes and is subject to field inspection and verification.

APPROVED

Limited building only review
Permit holder responsible for full compliance with the code

05/07/2021

Bartlett

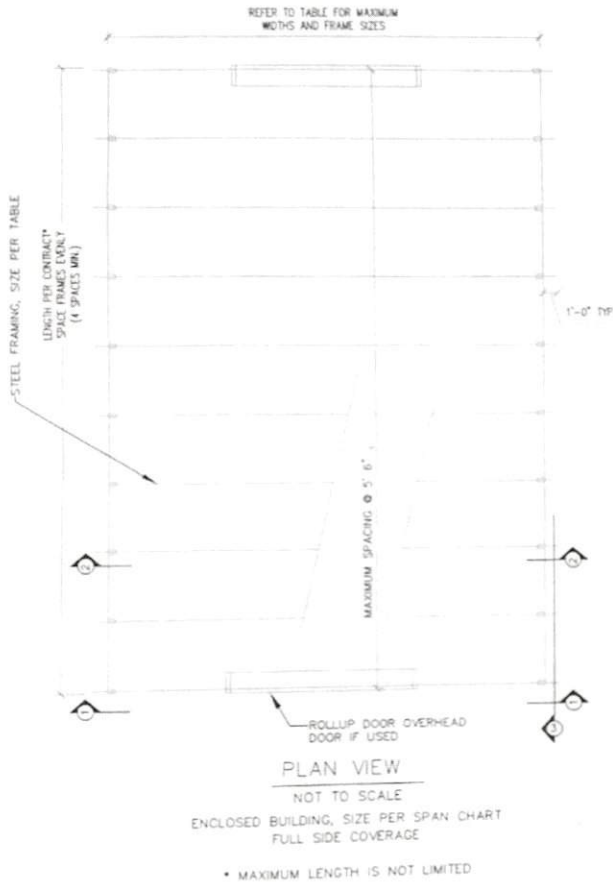

NOTE:
ALL SIZES ARE 3x2 TUBE
STEEL (Fy = 50KSI)

MAX HEIGHT	9'	12'
12' 0"	11 GA	9 GA
16' 0"	9 GA	9 GA
20' 0"	9 GA	9 GA
24' 0"	9 GA	9 GA
28' 0"	9 GA	9 GA

BRACE LOCATED @ 2'-2" ABOVE EAVE
BRACE LOCATED @ 1'-6" ABOVE EAVE
BRACE LOCATED @ 1'-0" ABOVE EAVE

TO USE SPAN CHART:

1. SELECT WIDTH OF BUILDING DESIRED
2. SELECT EAVE HEIGHT OF BUILDING - THIS IS DIMENSION TO TOP OF COLUMN FROM GRADE
3. FOLLOW HORIZONTAL LINE FROM WIDTH TO CORRECT HEIGHT COLUMN
4. SELECT GAGE LISTED
5. INTERPOLATION BETWEEN SIZES IS NOT PERMITTED
6. THIS TABLE TO BE USED WITH DRAWINGS S1 THRU S6 ONLY
7. CENTER BRACE REQUIRED IF SIZE IS HATCHED AS SHOWN. LOCATION SPECIFIED @ RIGHT OF TABLE.



BARTLETT
ENGINEERING & SURVEYING, PC

1906 NASH STREET NORTH
WILSON, NORTH CAROLINA 27893
TEL (252)399-0704 FAX (252)399-0804

DATE: DECEMBER 2020	CADFILE: 0743BDT12-A
SCALE: NO SCALE	DRAWN BY: LR
CLIENT: CARSTRU	SURVEYED BY:

CAROLINA STRUCTURAL, LLC
4241 WILLIAMSON ROAD
WILSON, NC 27893

12'-28' WIDE 6/12 PITCH
ENCLOSED BUILDING
130 MPH WIND LOAD

PLAN VIEW

S1

CAROLINA STRUCTURAL, LLC
 4241 WILLIAMSON ROAD
 WILSON, NC 27893

12'-28" WIDE 6/12 PITCH
 ENCLOSED BUILDING
 130 MPH WIND LOAD

SECTION 1

S3

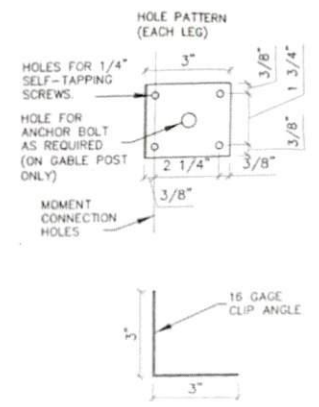
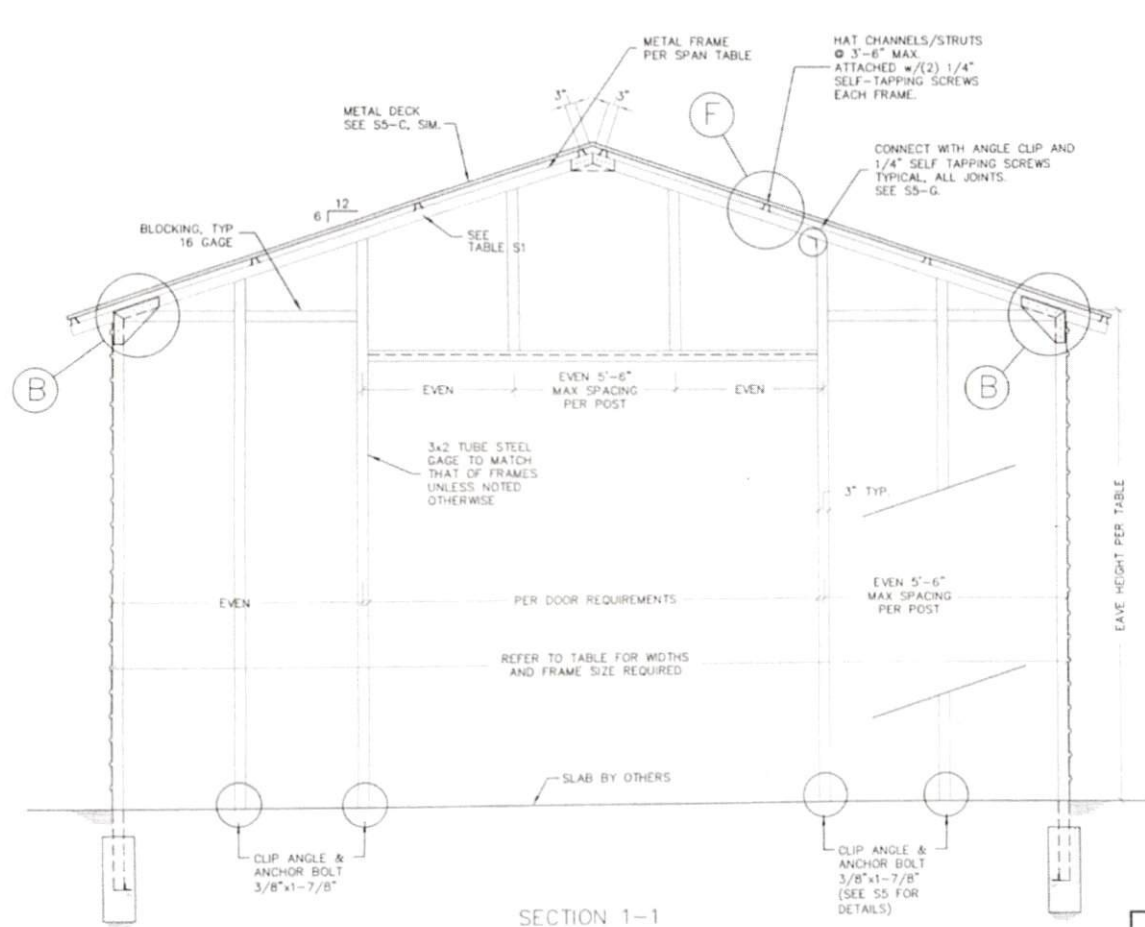

NOTE:
 1) TYPICAL CONNECTION = 2 SCREWS (MIN.) PER LEG IN A DIAGONAL PATTERN
 2) MOMENT CONNECTION = 2 SCREWS (MIN.) IN HOLES NOTED.



NOTE:
 BLOCKING ATTACHED WITH 16 GAGE CLIP ANGLE.
 SEE S5 FOR DETAILS

SECTION 1-1
 WITH GARAGE DOOR
 NOT TO SCALE

BARTLETT
 ENGINEERING & SURVEYING, PC

1906 NASH STREET NORTH
 WILSON, NORTH CAROLINA 27893
 TEL (252)399-0704 FAX (252)399-0804

DATE: DECEMBER 2020	CADFILE: 0743BDT12-C
SCALE: NO SCALE	DRAWN BY: LR
CLIENT: CARSTRU	SURVEYED BY:

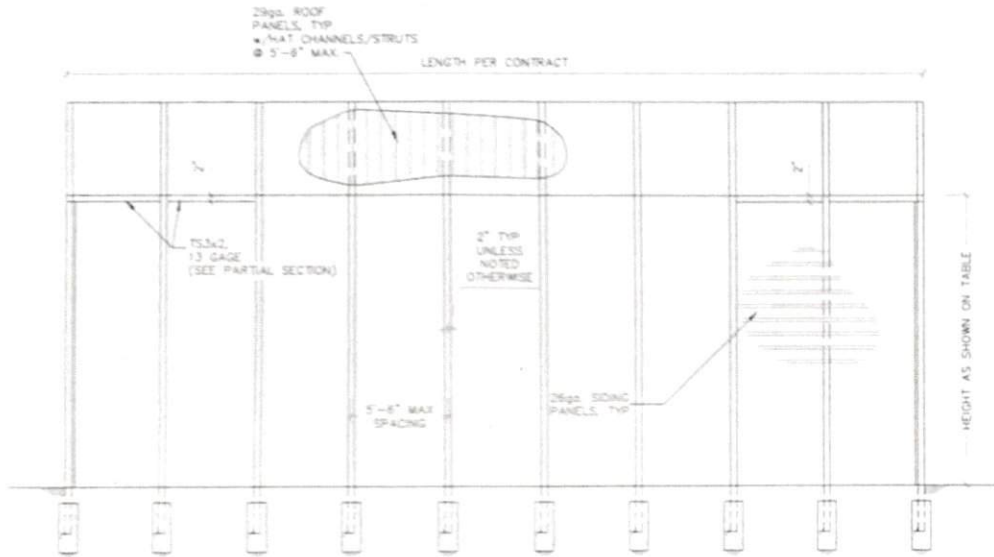

ENCLOSED BUILDING, SIZE PER TABLE

SECTION 3-3
NOT TO SCALE

8" x 1" BRACE (10 GAGE)
OR 1" BRACE w/ 2 DOORS
COINCIDE ON ONE POST

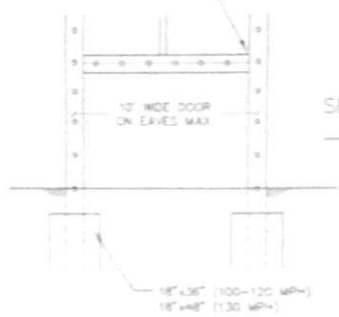

SECTION 3-3 (PARTIAL)
FOR GARAGE DOOR
NOT TO SCALE

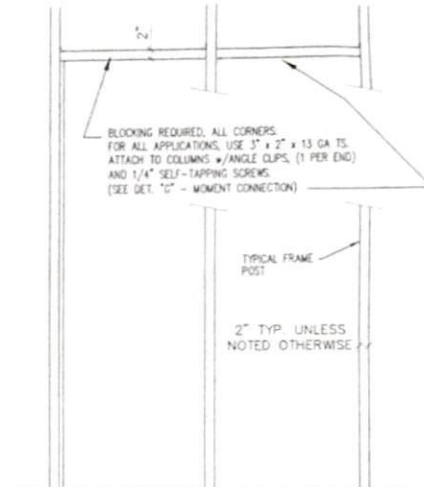

FOOTINGS NOT SHOWN FOR CLARITY

SECTION 3-3 (PARTIAL)
NOT TO SCALE



BARTLETT ENGINEERING & SURVEYING, PC	
1906 NASH STREET NORTH WILSON, NORTH CAROLINA 27893 TEL (252)399-0704 FAX (252)399-0804	
DATE: DECEMBER 2020	CADFILE: 07438DT12-D
SCALE: NO SCALE	DRAWN BY: LR
CLIENT: CARSTRU	SURVEYED BY:

CAROLINA STRUCTURAL, LLC
4241 WILLIAMSON ROAD
WILSON, NC 27893

12'-28" WIDE 6/12 PITCH
ENCLOSED BUILDING
130 MPH WIND LOAD

SECTION 3

S4

NOTES:

1. DESIGN SPECIFICATION: NORTH CAROLINA STATE BUILDING CODE (LATEST EDITION) AND INTERNATIONAL BUILDING CODE (LATEST EDITION) WITH NORTH CAROLINA AMENDMENTS.
DESIGN LOAD:
 ROOF LIVE LOAD: 20 PSF
 SNOW LOAD : 20 PSF
 WIND VELOCITY: 130 MPH
 FRAME SIZING DETERMINED BY MEMBER STRESS.
 LL+DL DEFLECTION LIMITED TO L/120.
 ROOF LL DEFLECTION L/150
 WALL LL DEFLECTION L/90
2. WHERE A DETAIL IS SHOWN ON STRUCTURAL DRAWINGS FOR ONE CONDITION, IT SHALL APPLY TO ALL SIMILAR OR LIKE CONDITIONS, UNLESS NOTED OR SHOWN OTHERWISE.
3. IF CONTRACTOR FINDS A DIFFERENCE BETWEEN THESE DRAWINGS AND EXISTING ELEVATIONS, OR OTHER CONDITIONS WHICH PROHIBIT EXECUTION OF THE WORK AS DIRECTED ON THESE DRAWINGS, CONTRACTOR SHALL NOTIFY ENGINEER IMMEDIATELY.
4. ALL ITEMS SHALL BE TIGHTLY ANCHORED OR ATTACHED SQUARE, PLUMB AND TRUE, OR IN OTHER PLANES OR SHAPES AS SHOWN ON THE DRAWINGS. JOINTS SHALL BE TIGHT, EVEN, AND FREE OF OFFSETS. NO FIELD ALTERING OF ANY MEMBERS WILL BE ALLOWED THAT WILL CAUSE THEM NOT TO BE IN ACCORDANCE WITH THE DRAWINGS AND SPECIFICATIONS, WITHOUT WRITTEN APPROVAL OF THE DESIGN ENGINEER.
5. GENERAL CONTRACTOR IS RESPONSIBLE TO PROVIDE ADEQUATE SHORING, BRACING OR SUPPORT TO PREVENT MOVEMENT, SETTLEMENT, OR DAMAGE TO THE STRUCTURE DURING CONSTRUCTION PROCEDURES ASSOCIATED WITH THIS PROJECT.
6. CONCRETE: CONCRETE MINIMUM COMPRESSIVE STRENGTH AT 28 DAYS SHALL BE 3000 PSI.
7. CONCRETE WORK SHALL COMPLY WITH ACI "SPECIFICATIONS FOR STRUCTURAL CONCRETE FOR BUILDINGS (ACI 301) AND APPLICABLE PROVISIONS OF ACI 318.
8. ALL FOOTER FOUNDATIONS SHALL BE PLACED ON COMPETENT SOIL.
9. DRILL AUGER PILING HOLES IN UNDISTURBED EARTH.
10. ALL GALVANIZING SHALL BE PERFORMED AFTER FABRICATION, AND IN ACCORDANCE WITH ASTM A123 AND/OR A153.
11. THE MINIMUM YIELD STRENGTH OF THE STEEL USED IN THE LIGHT GAUGE METAL FRAMES SHALL BE 55,000 PSI, FOR RAW OR GALVANIZED TUBES.
12. THE MINIMUM YIELD STRENGTH OF THE STEEL USED FOR THE LIGHT GAUGE METAL DECK SHALL BE 80,000 PSI, DECKING PANELS SHALL COVER THREE SPANS, MINIMUM.
13. THE LIGHT GAUGE METAL FRAMES AND DECK SHALL BE OF THE GAUGE INDICATED ON THE PLAN/DETAILS.
14. ALL WELDING SHALL BE IN ACCORDANCE WITH AWS D1.1.
15. ALL WELDS SHALL BE COATED WITH GALVANIZE PRIMER & PAINT AFTER WELDING.

CAROLINA STRUCTURAL, LLC
4241 WILLIAMSON ROAD
WILSON, NC 27893

12'-28" WIDE 6/12 PTCH
ENCLOSED BUILDING
130 MPH WIND LOAD

SPECIFICATIONS

S6



BARTLETT ENGINEERING & SURVEYING, PC	
1906 NASH STREET NORTH WILSON, NORTH CAROLINA 27893 TEL (252)399-0704 FAX (252)399-0804	
DATE: DECEMBER 2020	CADFILE: 074380T12-F
SCALE: NO SCALE	DRAWN BY: LR
CLIENT: CARSTRU	SURVEYED BY: