



John Thomas
90 Reserve Drive
Fuquay Varina NC 27526

STRUCTURAL DESIGN

ENCLOSED BUILDING

**MAXIMUM 24'- 0" WIDE X 17'- 0" EAVE HEIGHT-
BOX EAVE FRAME AND BOW FRAME**

9 August 2019

Revision 0

M&A Project No. 19105S

Prepared for:

**Carport Central, Inc.
737 South Main Street
Mount Airy, NC 27030**

Prepared by:

Moore and Associates Engineering and Consulting, Inc.

**1009 East Avenue
North Augusta, SC 29841**

**401 S. Main Street, Suite 200
Mount Airy, NC 27030**



**MOORE AND ASSOCIATES
ENGINEERING AND CONSULTING**

		I HAVE RESEARCHED THIS CHAPTER AND THE LOUISIANA STATE UNIFORM CONSTRUCTION CODE AND TO THE BEST OF MY KNOWLEDGE AND BELIEF, THESE DRAWINGS ARE IN COMPLIANCE THEREWITH. I TAKE FULL RESPONSIBILITY FOR THE CONTENTS OF THESE PLANS.	

MOORE AND ASSOCIATES
ENGINEERING AND CONSULTING, INC.

DRAWN BY: LT

CHECKED BY: PDH

PROJECT MGR: WSM

CLIENT: CC

CARPOT CENTRAL, INC.
737 SOUTH MAIN STREET
MOUNT AIRY, NC 27030
24'-0" x 17'-0" ENCLOSED STRUCTURE

DATE: 8-9-19

SHT. 1

SCALE: NTS

DWG. NO: SK-3

JOB NO: 1910SS

REV: 0

THIS DOCUMENT IS THE PROPERTY OF MOORE AND ASSOCIATES ENGINEERING AND CONSULTING. THE UNAUTHORIZED REPRODUCTION, COPYING, OR OTHERWISE USE OF THIS DOCUMENT IS STRICTLY PROHIBITED AND ANY INFRINGEMENT THEREUPON MAY BE SUBJECT TO LEGAL ACTION.

	<p>Professional Certification. I hereby certify that these documents were prepared or approved by me, and that I am a duly licensed professional engineer under the laws of the State of Maryland, License No. 49744, Expiration Date <u>6/6/20</u></p>		

MOORE AND ASSOCIATES ENGINEERING AND CONSULTING, INC.	DRAWN BY: LT	CARPORT CENTRAL, INC. 737 SOUTH MAIN STREET MOUNT AIRY, NC 27030 24'-0" x 17'-0" ENCLOSED STRUCTURE		
	CHECKED BY: PDH	PROJECT MGR: VSM	DATE: 8-9-19	SCALE: NTS
<small>THIS DOCUMENT IS THE PROPERTY OF MOORE AND ASSOCIATES ENGINEERING AND CONSULTING. THE UNAUTHORIZED REPRODUCTION, COPYING, OR OTHERWISE USE OF THIS DOCUMENT IS STRICTLY PROHIBITED AND ANY INFRACTION THEREUPON MAY BE SUBJECT TO LEGAL ACTION.</small>	CLIENT: CC	SHT: 1A	DWG. NO.: SK-3	JOB NO.: 191055
				REV.: 0

INSTALLATION NOTES AND SPECIFICATIONS

- 1 DESIGN IS FOR MAXIMUM 24'-0" WIDE x 17'-0" EAVE HEIGHT ENCLOSED STRUCTURES
- 2 DESIGN WAS DONE IN ACCORDANCE WITH THE 2018 NORTH CAROLINA BUILDING CODE, 2017 FLORIDA BUILDING CODE (FBC) 6TH EDITION, 2006 INTERNATIONAL BUILDING CODE (IBC), 2009 IBC, 2012 IBC, 2015 IBC, AND 2018 IBC
- 3 DESIGN LOADS ARE AS FOLLOWS:
 - A) DEAD LOAD = 15 PSF
 - B) LIVE LOAD = 12 PSF
 - C) GROUND SNOW LOAD = 37 PSF AT 5'-0" OC SPACING
= 41 PSF AT 4'-0" OC SPACING

NOTE UNBALANCED SNOW LOADS DUE TO DRIFTING HAVE NOT BEEN EVALUATED
- 4 ULTIMATE WIND SPEED 105 TO 127 MPH (NOMINAL WIND SPEED 82 TO 99 MPH)
MAXIMUM RAFTER/COLUMN AND END COLUMN SPACING = 50 FEET
- 5 ULTIMATE WIND SPEED 105 TO 140 MPH (NOMINAL WIND SPEED 82 TO 108 MPH)
MAXIMUM RAFTER/COLUMN AND END COLUMN SPACING = 40 FEET
- 6 END WALL COLUMNS (POSTS) ARE SIMILAR TO SIDE WALL POSTS IN SIZE AND SPACING UNLESS NOTED OTHERWISE
- 7 RISK CATEGORY I
- 8 WIND EXPOSURE CATEGORY B
- 9 SPECIFICATIONS APPLICABLE TO 29 GAUGE METAL PANELS FASTENED DIRECTLY TO 2 1/4" x 2 1/4" - 14 GAUGE TUBE STEEL (TS) FRAMING MEMBERS (UNLESS NOTED OTHERWISE)
- 10 AVERAGE FASTENER SPACING ON-CENTERS ALONG RAFTERS OR HAT CHANNELS, AND COLUMNS (INTERIOR OR END) = 8 INCHES
- 11 FASTENERS CONSIST OF #12-14x3/4" (UNLESS OTHERWISE NOTED) SELF-DRILLING FASTENER (SDF), USE CONTRA SEAL WASHER WITH EXTERIOR FASTENERS. SPECIFICATIONS APPLICABLE ONLY FOR MEAN ROOF HEIGHT OF 20 FEET OR LESS, AND ROOF SLOPES OF 14" (3:12) PITCH OR LESS SPACING REQUIREMENTS FOR OTHER ROOF HEIGHTS AND/OR SLOPES MAY VARY
- 12 ANCHORS SHALL BE INSTALLED THROUGH BASE RAIL WITHIN 6" OF EACH COLUMN
- 13 STANDARD GROUND ANCHORS (SOIL NAILS) CONSIST OF #4 REBAR W/ WELDED NUT x 36" LONG SOIL NAILS MAY BE USED FOR MAXIMUM WIND V = 145 MPH AND IN SUITABLE SOIL CONDITIONS. OPTIONAL ANCHORAGE MAY BE USED IN UNSUITABLE SOILS AND MUST BE USED FOR WIND V > 145 MPH AND/OR IN UNSUITABLE SOILS AS NOTED
- 14 WIND FORCES GOVERN OVER SEISMIC FORCES. SEISMIC PARAMETERS ANALYZED ARE:
 - SOIL SITE CLASS = D
 - RISK CATEGORY I/II/III
 - R = 3.25
 - $I_p = 1.0$
 - $S_{DS} = 2.039 g$
 - $S_{D1} = 1.258 g$
 - $V = C_s W$

** CarportCentral Authorized Manufacturer Of Customer Use Only**

John Thomas
90 Reserve Drive
Fuquay Varina NC 27526

CARPORT CENTRAL, INC.
 737 SOUTH MAIN STREET
 MOUNT AIRY, NC 27030
 24'-0"x17'-0" ENCLOSED STRUCTURE

MOORE AND ASSOCIATES
ENGINEERING AND CONSULTING, INC.

DRAWN BY: LT

CHECKED BY: PDH

PROJECT MGR: WSM

CLIENT: CC

DATE: 8-9-19

SHT. 3

SCALE: NTS

DWG. NO: SK-3

JOB NO: 19105S

REV: 0

THIS DOCUMENT IS THE PROPERTY OF MOORE AND ASSOCIATES ENGINEERING AND CONSULTING. THE UNAUTHORIZED REPRODUCTION, COPYING, OR OTHERWISE USE OF THIS DOCUMENT IS STRICTLY PROHIBITED AND ANY INFRINGEMENT THEREUPON MAY BE SUBJECT TO LEGAL ACTION.

BOX EAVE FRAME RAFTER STRUCTURE

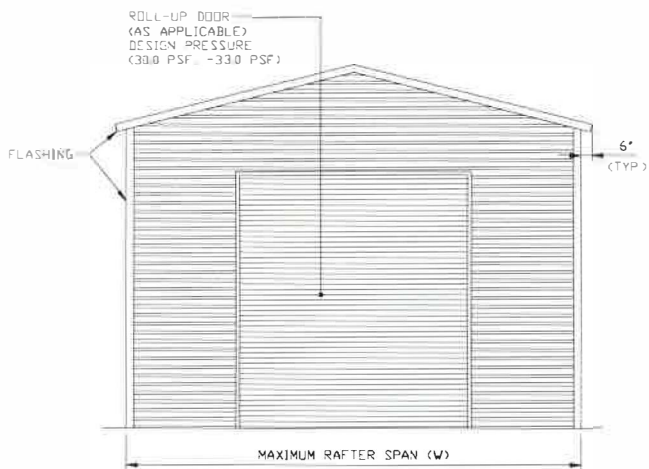

TYPICAL END ELEVATION-HORIZONTAL ROOF
SCALE: NTS

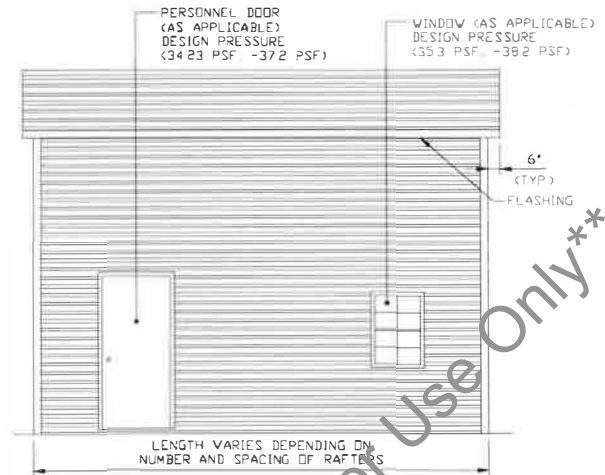

TYPICAL SIDE ELEVATION-HORIZONTAL ROOF
SCALE: NTS

BOW FRAME RAFTER STRUCTURE

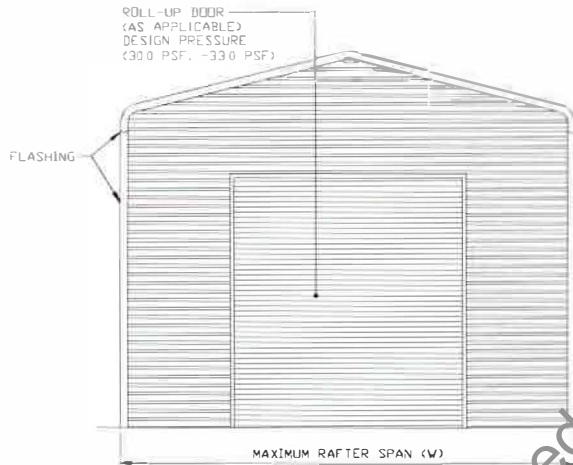

TYPICAL END ELEVATION
SCALE: NTS

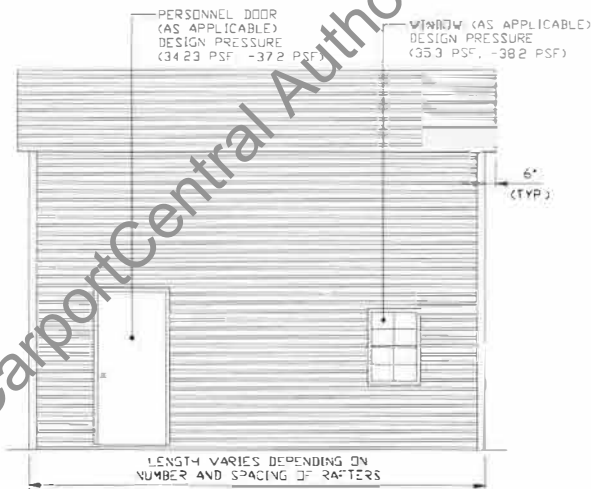

TYPICAL SIDE ELEVATION
SCALE: NTS

John Thomas
90 Reserve Drive
Fuquay Varina NC 27526

CARPORT CENTRAL, INC.
737 SOUTH MAIN STREET
MOUNT AIRY, NC 27030
24'-0" x 17'-0" ENCLOSED STRUCTURE

MOORE AND ASSOCIATES
ENGINEERING AND CONSULTING, INC.

DRAWN BY: LT

CHECKED BY: PDH

PROJECT MGR: WSM

CLIENT: CC

DATE: 8-9-19

SHT. 4

SCALE: NTS

DWG. NO: SK-3

JOB NO: 1910SS

REV: 0

THIS DOCUMENT IS THE PROPERTY OF MOORE AND ASSOCIATES ENGINEERING AND CONSULTING. THE UNAUTHORIZED REPRODUCTION, COPYING, OR OTHERWISE USE OF THIS DOCUMENT IS STRICTLY PROHIBITED AND ANY INFRINGEMENT THEREUPON MAY BE SUBJECT TO LEGAL ACTION.

20'-0" < W ≤ 24'-0" SPAN

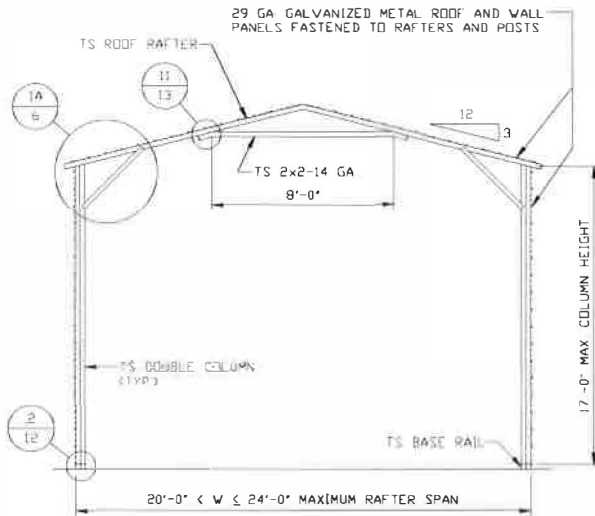

TYPICAL RAFTER/COLUMN END FRAME SECTION

SCALE: NTS

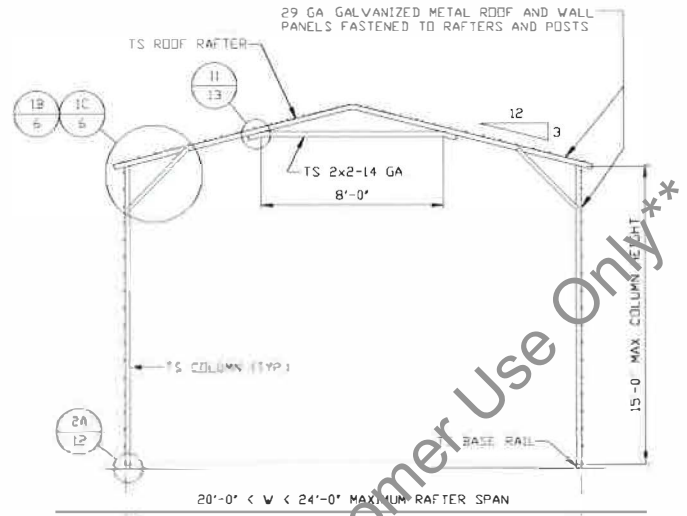

TYPICAL RAFTER/COLUMN END FRAME SECTION

SCALE: NTS

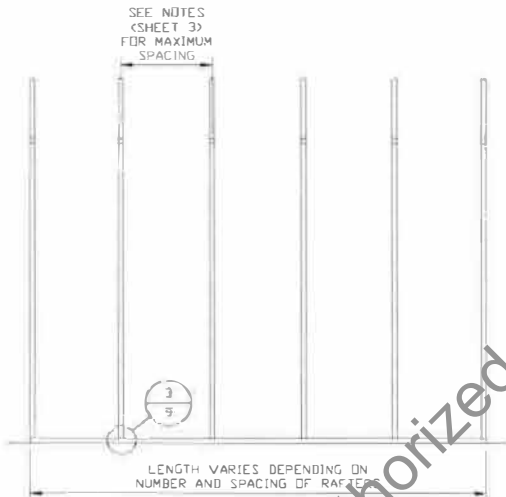

TYPICAL RAFTER/COLUMN SIDE FRAMING SECTION

SCALE: NTS

**** CarportCentral Authorized Manufacturer Of Customer Use Only****

John Thomas
 90 Reserve Drive
 Fuquay Varina NC 27526

CARPORT CENTRAL, INC.
 737 SOUTH MAIN STREET
 MOUNT AIRY, NC 27030
 24'-0" x 17'-0" ENCLOSED STRUCTURE

MOORE AND ASSOCIATES
 ENGINEERING AND CONSULTING, INC.

DRAWN BY: LT

CHECKED BY: PDH

PROJECT MGR: VSM

CLIENT: CC

DATE: 8-9-19

SHT. 5

SCALE: NTS

DWG. NO: SK-3

JOB NO: 191055

REV: 0

THIS DOCUMENT IS THE PROPERTY OF MOORE AND ASSOCIATES ENGINEERING AND CONSULTING. THE UNAUTHORIZED REPRODUCTION, COPYING, OR OTHERWISE USE OF THIS DOCUMENT IS STRICTLY PROHIBITED AND ANY INFRINGEMENT THEREUPON MAY BE SUBJECT TO LEGAL ACTION.

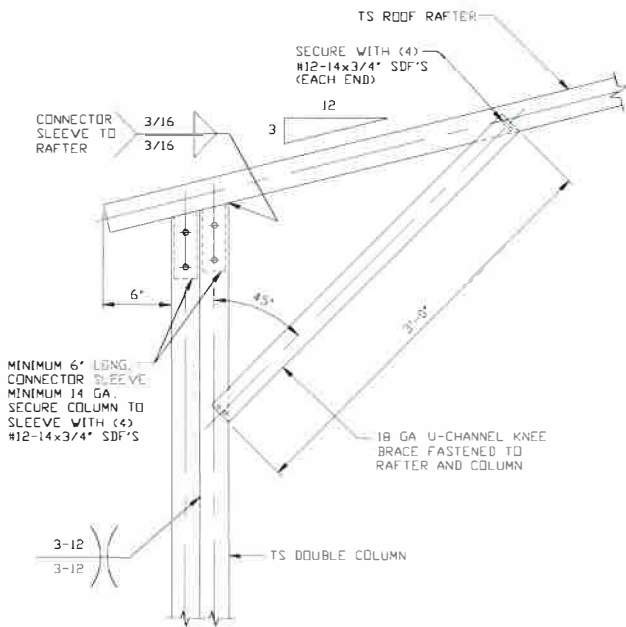

1A
BOX EAVE RAFTER COLUMN CONNECTION DETAIL FOR HEIGHTS 15'-0" < TO <= 17'-0"
 SCALE: NTS

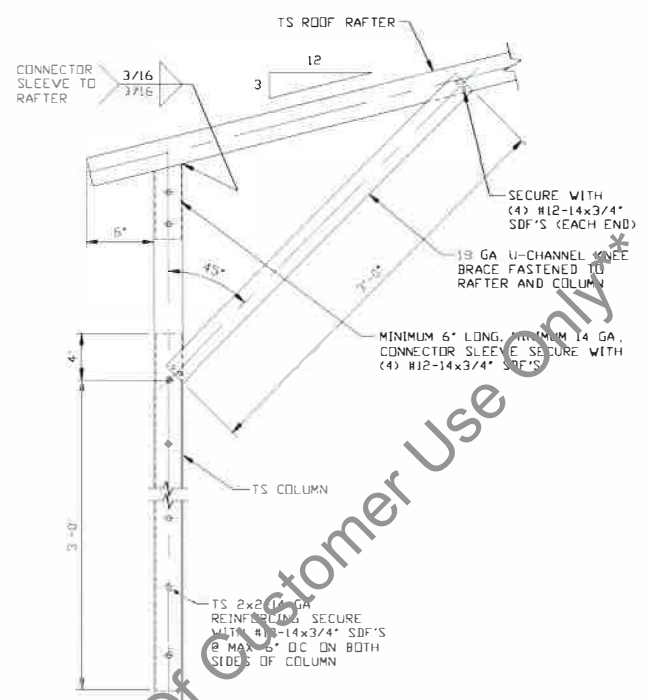

1B
BOX EAVE RAFTER COLUMN CONNECTION DETAIL FOR HEIGHTS 12'-0" < TO <= 15'-0"
 SCALE: NTS

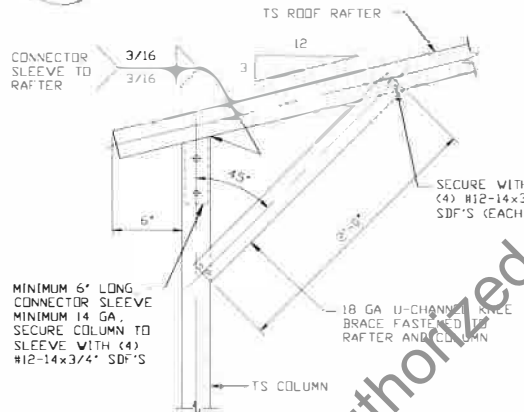

1C
BOX EAVE RAFTER COLUMN CONNECTION DETAIL FOR HEIGHTS < 12'-0"
 SCALE: NTS

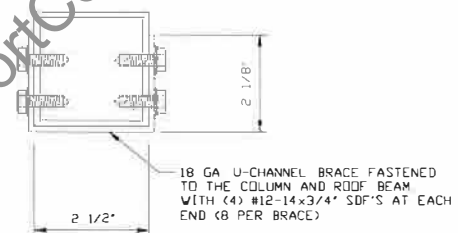

BRACE SECTION
 SCALE: NTS

John Thomas
90 Reserve Drive
Fuquay Varina NC 27526
 CARPORT CENTRAL, INC.
 737 SOUTH MAIN STREET
 MOUNT AIRY, NC 27030
 24'-0" x 17'-0" ENCLOSED STRUCTURE

MOORE AND ASSOCIATES ENGINEERING AND CONSULTING, INC.

DRAWN BY: LT			
CHECKED BY: PDH			
PROJECT MGR: WSM	DATE: 8-9-19	SCALE: NTS	JOB NO: 191055
CLIENT: CC	SHT. 6	DWG. NO: SK-3	REV.: 0

THIS DOCUMENT IS THE PROPERTY OF MOORE AND ASSOCIATES ENGINEERING AND CONSULTING. THE UNAUTHORIZED REPRODUCTION, COPYING, OR OTHERWISE USE OF THIS DOCUMENT IS STRICTLY PROHIBITED AND ANY INFRINGEMENT THEREUPON MAY BE SUBJECT TO LEGAL ACTION.

BASE RAIL ANCHORAGE OPTIONS

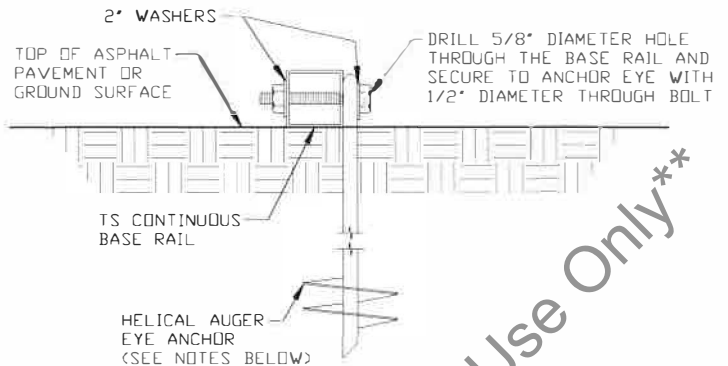
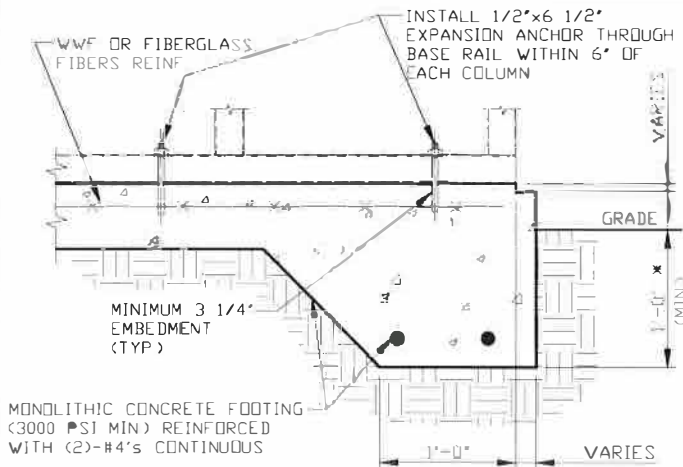

3A CONCRETE MONOLITHIC SLAB BASE RAIL ANCHORAGE
 SCALE: NTS
 MINIMUM ANCHOR EDGE DISTANCE IS 4"
 * COORDINATE WITH LOCAL CODES/ORD

3B HELICAL AUGER ANCHORAGE
 SCALE: NTS (CAN BE USED FOR ASPHALT)

GENERAL NOTES

NOTE: CONCRETE MONOLITHIC SLAB DESIGN BASED ON MINIMUM SOIL BEARING CAPACITY OF 1,500 PSF.

CONCRETE:

CONCRETE SHALL HAVE A MINIMUM SPECIFIED COMPRESSIVE STRENGTH OF 3,000 PSI AT 28 DAYS

COVER OVER REINFORCING STEEL:

FOR FOUNDATIONS, MINIMUM CONCRETE COVER OVER REINFORCING BARS SHALL BE PER ACI-318:
 3" IN FOUNDATIONS WHERE THE CONCRETE IS CAST AGAINST AND PERMANENTLY IN CONTACT WITH THE EARTH OR EXPOSED TO THE EARTH OR WEATHER, AND 1 1/2" ELSEWHERE.

REINFORCING STEEL:

THE TURNDOWN REINFORCING STEEL SHALL BE ASTM A615 GRADE 60 THE SLAB REINFORCEMENT SHALL BE WELDED WIRE FABRIC MEETING ASTM A185 OR FIBERGLASS FIBER REINFORCEMENT.

REINFORCEMENT MAY BE BENT IN THE SHOP OR THE FIELD PROVIDED:

- 1 REINFORCEMENT IS BENT COLD
- 2 THE DIAMETER OF THE BEND, MEASURED ON THE INSIDE OF THE BAR, IS NOT LESS THAN SIX-BAR DIAMETER.
- 3 REINFORCEMENT PARTIALLY EMBEDDED IN CONCRETE SHALL NOT BE FIELD BENT.

HELICAL AUGER ANCHOR NOTES:

- 1 FOR VERY DENSE AND/OR CEMENTED SANDS, COARSE GRAVEL AND COBBLES, CALICHE, PRELOADED SILTS AND CLAYS, USE MINIMUM (2) 4" HELICES WITH MINIMUM 30" EMBEDMENT OR SINGLE 6" HELIX WITH MINIMUM 50" EMBEDMENT
- 2 FOR CORAL USE MINIMUM (2) 4" HELICES WITH MINIMUM 30" EMBEDMENT OR SINGLE 6" HELIX WITH MINIMUM 50" EMBEDMENT
- 3 FOR MEDIUM DENSE COARSE SANDS, SANDY GRAVELS, VERY STIFF SILTS AND CLAYS USE MINIMUM (2) 4" HELICES WITH MINIMUM 30" INCH EMBEDMENT OR SINGLE 6" HELIX WITH MINIMUM 50" EMBEDMENT
- 4 FOR LOOSE TO MEDIUM DENSE SANDS, FIRM TO STIFF CLAYS AND SILT ALLUVIAL FILL, USE MINIMUM (2) 6" HELICES WITH MINIMUM 50" EMBEDMENT
- 5 FOR VERY LOSE TO MEDIUM DENSE SANDS, FIRM TO STIFFER CLAYS AND SILTS, ALLUVIAL FILL, USE MINIMUM (2) 8" HELICES WITH MINIMUM 50" EMBEDMENT

John Thomas
 90 Reserve Drive
 Fuquay Varina NC 27526

CARPOR CENTRAL, INC.
 737 SOUTH MAIN STREET
 MOUNT AIRY, NC 27030
 24'-0" x 17'-0" ENCLOSED STRUCTURE

MOORE AND ASSOCIATES ENGINEERING AND CONSULTING, INC.

DRAWN BY: LT

CHECKED BY: PDH

PROJECT MGR: WSM

CLIENT: CC

DATE: 8-9-19

SHT. 9

SCALE: NTS

DWG. NO: SK-3

JOB NO: 191055

REV: 0

THIS DOCUMENT IS THE PROPERTY OF MOORE AND ASSOCIATES ENGINEERING AND CONSULTING. THE UNAUTHORIZED REPRODUCTION, COPYING, OR OTHERWISE USE OF THIS DOCUMENT IS STRICTLY PROHIBITED AND ANY INFRINGEMENT THEREUPON MAY BE SUBJECT TO LEGAL ACTION.

BASE RAIL ANCHORAGE OPTIONS

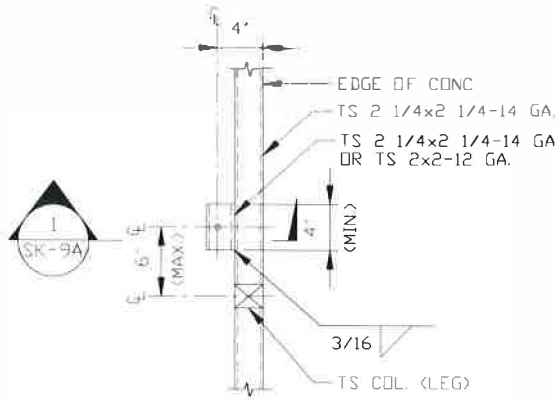

TYPICAL ANCHOR DETAIL WHEN BASE RAIL IS NEAR EDGE OF CONCRETE
SCALE: NTS

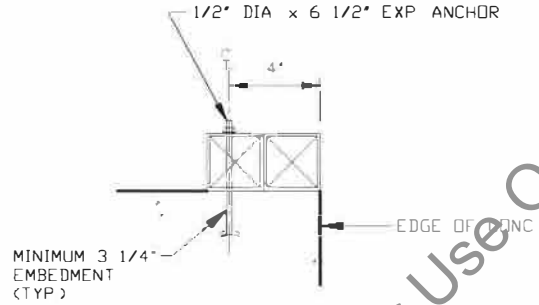

SECTION 1
SCALE: NTS

**** CarportCentral Authorized Manufacturer Of Customer Use Only****

**John Thomas
90 Reserve Drive
Fuquay Varina NC 27526**

CARPORT CENTRAL, INC.
737 SOUTH MAIN STREET
MOUNT AIRY, NC 27030
24'-0" x 17'-0" ENCLOSED STRUCTURE

**MOORE AND ASSOCIATES
ENGINEERING AND CONSULTING, INC.**

DRAWN BY: LT

CHECKED BY: PDH

PROJECT MGR: WSM

CLIENT: CC

DATE: 8-9-19

SHT. 9A

SCALE: NTS

DWG. NO: SK-3

JOB NO: 191056

REV: 0

THIS DOCUMENT IS THE PROPERTY OF MOORE AND ASSOCIATES ENGINEERING AND CONSULTING. THE UNAUTHORIZED REPRODUCTION, COPYING, OR OTHERWISE USE OF THIS DOCUMENT IS STRICTLY PROHIBITED AND ANY INFRINGEMENT THEREUPON MAY BE SUBJECT TO LEGAL ACTION.

BOX EAVE RAFTER END WALL AND SIDE WALL OPENINGS

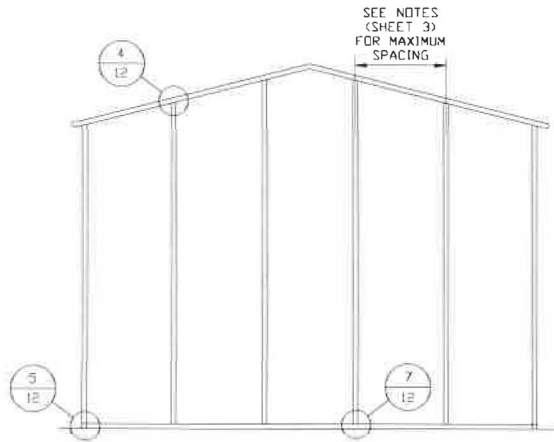

TYPICAL BOX EAVE RAFTER END WALL FRAMING SECTION

SCALE: NTS

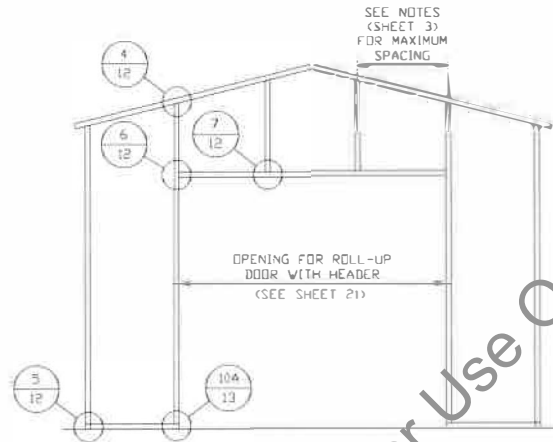

TYPICAL BOX EAVE RAFTER END WALL OPENINGS FRAMING SECTION

SCALE: NTS

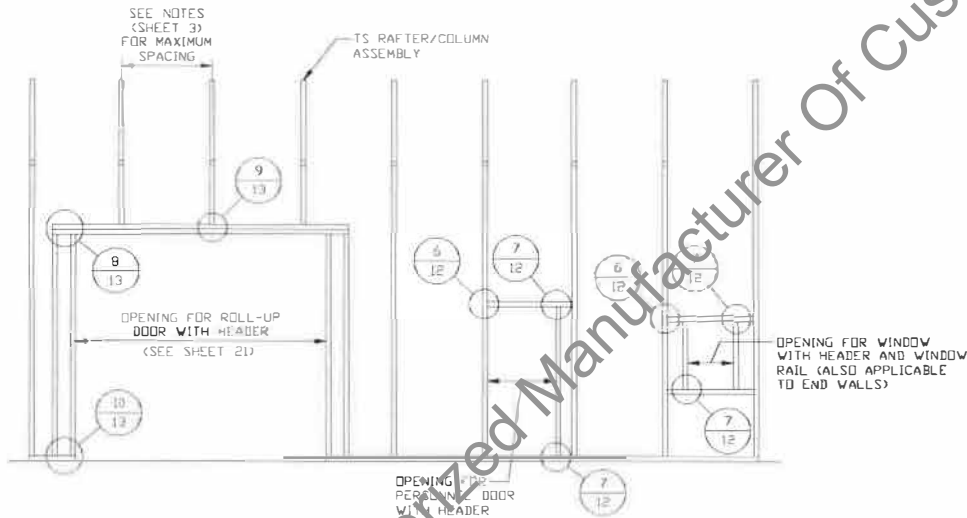

TYPICAL BOX EAVE RAFTER SIDE WALL OPENINGS FRAMING SECTION

SCALE: NTS

**** CarportCentral Authorized Manufacturer Of Customer Use Only****

**John Thomas
90 Reserve Drive
Fuquay Varina NC 27526**

CARPOT CENTRAL, INC.
737 SOUTH MAIN STREET
MOUNT AIRY, NC 27030
24'-0" x 17'-0" ENCLOSED STRUCTURE

**MOORE AND ASSOCIATES
ENGINEERING AND CONSULTING, INC.**

DRAWN BY: LT

CHECKED BY: PDH

PROJECT MGR: WSH

CLIENT: CC

DATE: 8-9-19

SHT. 10

SCALE: NTS

DWG. NO: SK-3

JOB NO: 191055

REV: 0

THIS DOCUMENT IS THE PROPERTY OF MOORE AND ASSOCIATES ENGINEERING AND CONSULTING. THE UNAUTHORIZED REPRODUCTION, COPYING, OR OTHERWISE USE OF THIS DOCUMENT IS STRICTLY PROHIBITED AND ANY INFRINGEMENT THEREUPON MAY BE SUBJECT TO LEGAL ACTION.

CONNECTION DETAILS

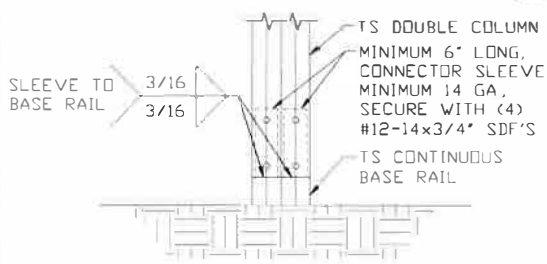

**2 RAFTER COLUMN/
BASE RAIL
CONNECTION DETAIL**
SCALE: NTS

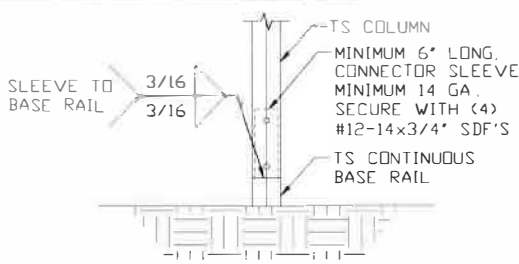

**2A RAFTER COLUMN/
BASE RAIL
CONNECTION DETAIL**
SCALE: NTS

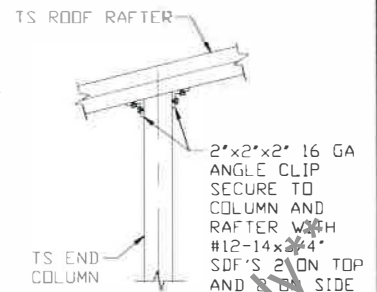

**4 END COLUMN/RAFTER
CONNECTION DETAIL**
SCALE: NTS

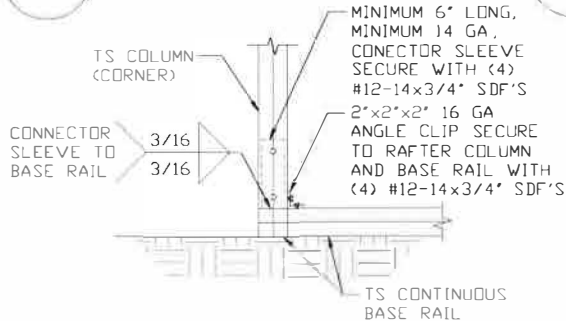

**5 END COLUMN/BASE RAIL
CONNECTION DETAIL**
SCALE: NTS

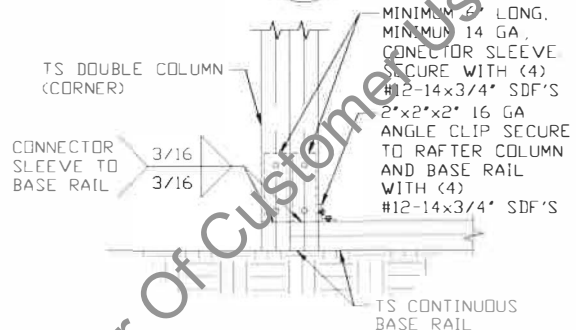

**5A END COLUMN/BASE RAIL
CONNECTION DETAIL**
SCALE: NTS

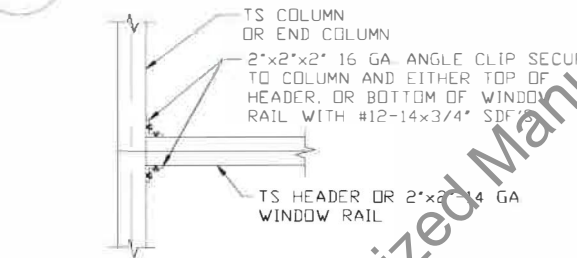

**6 COLUMN OR WINDOW
RAIL TO POST
CONNECTION DETAIL**
SCALE: NTS

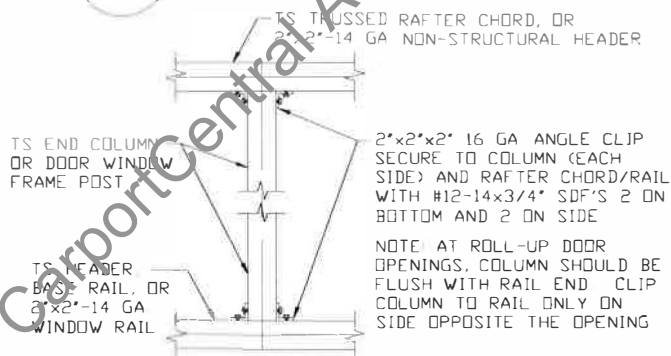

**7 COLUMN TO HEADER, BASE RAIL, OR
WINDOW RAIL CONNECTION DETAIL**
SCALE: NTS

**John Thomas
90 Reserve Drive
Fuquay Varina NC 27526**

CARPOT CENTRAL, INC.
737 SOUTH MAIN STREET
MOUNT AIRY, NC 27030
24'-0\"/>

**MOORE AND ASSOCIATES
ENGINEERING AND CONSULTING, INC.**

DRAWN BY: LT

CHECKED BY: PDH

PROJECT MGR: WSM

CLIENT: CC

DATE: 8-9-19

SHT. 12

SCALE: NTS

DWG. NO: SK-3

JOB NO: 191055

REV: 0

THIS DOCUMENT IS THE PROPERTY OF MOORE AND ASSOCIATES ENGINEERING AND CONSULTING. THE UNAUTHORIZED REPRODUCTION, COPYING, OR OTHERWISE USE OF THIS DOCUMENT IS STRICTLY PROHIBITED AND ANY INFRINGEMENT THEREUPON MAY BE SUBJECT TO LEGAL ACTION.

CONNECTION DETAILS

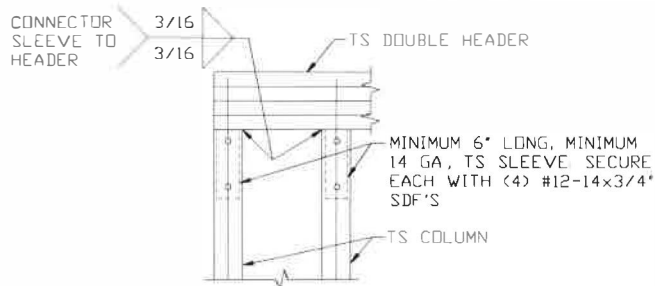

8
DOUBLE HEADER/COLUMN CONNECTION DETAIL
 SCALE: NTS

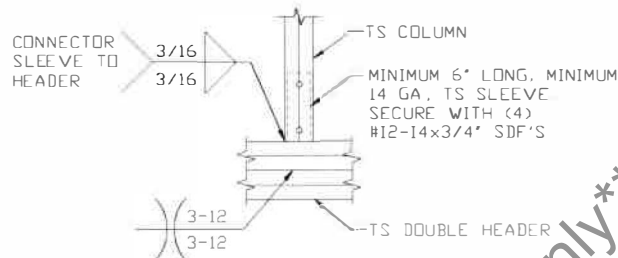

9
COLUMN/DOUBLE HEADER CONNECTION DETAIL
 SCALE: NTS

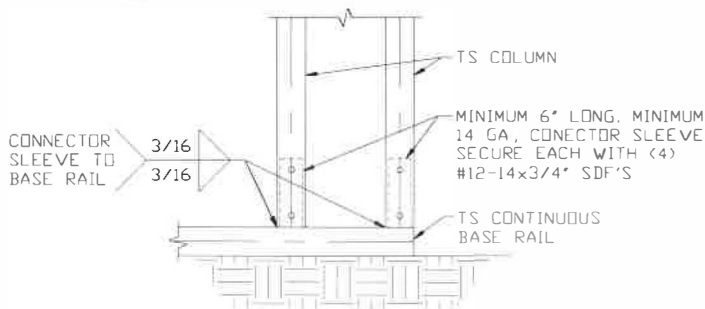

10
COLUMN/BASE RAIL CONNECTION DETAIL
 SCALE: NTS



10A
COLUMN/BASE RAIL CONNECTION DETAIL
 SCALE: NTS

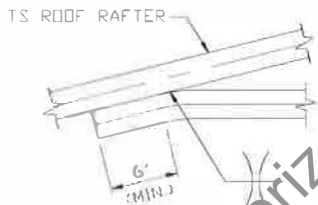

11
COLLAR TIE CONNECTION DETAIL
 SCALE: NTS

**** CarportCentral Authorized Manufacturer Of Customer Use Only****

John Thomas
90 Reserve Drive
Fuquay Varina NC 27526

CARPORT CENTRAL, INC.
 737 SOUTH MAIN STREET
 MOUNT AIRY, NC 27030
 24'-0" x 17'-0" ENCLOSED STRUCTURE

MOORE AND ASSOCIATES
ENGINEERING AND CONSULTING, INC.

DRAWN BY: LT

CHECKED BY: PDH

PROJECT MGR: VSM

CLIENT: CC

DATE: 8-9-19

SHT. 13

SCALE: NTS

DWG. NO: SK-3

JOB NO: 19105S

REV: 0

THIS DOCUMENT IS THE PROPERTY OF MOORE AND ASSOCIATES ENGINEERING AND CONSULTING. THE UNAUTHORIZED REPRODUCTION, COPYING, OR OTHERWISE USE OF THIS DOCUMENT IS STRICTLY PROHIBITED AND ANY INFRINGEMENT THEREUPON MAY BE SUBJECT TO LEGAL ACTION.

BOX EAVE RAFTER VERTICAL ROOF OPTION

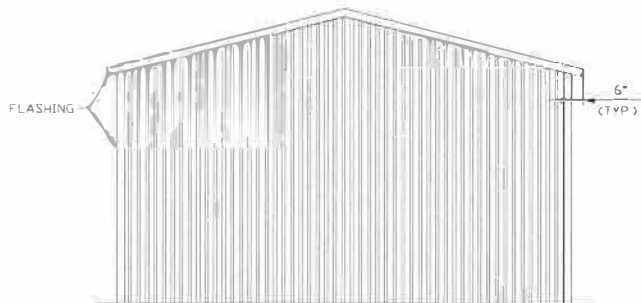

**TYPICAL END ELEVATION
VERTICAL ROOF**

SCALE: NTS

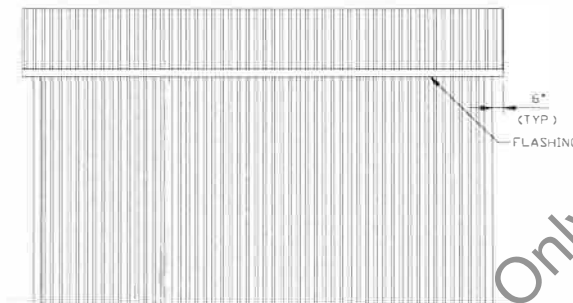

**TYPICAL SIDE ELEVATION
VERTICAL ROOF**

SCALE: NTS

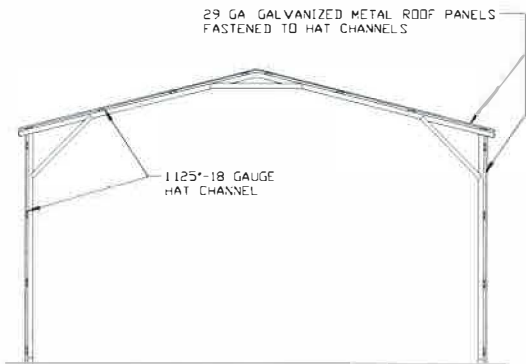

**TYPICAL SECTION
VERTICAL ROOF OPTION**

SCALE: NTS

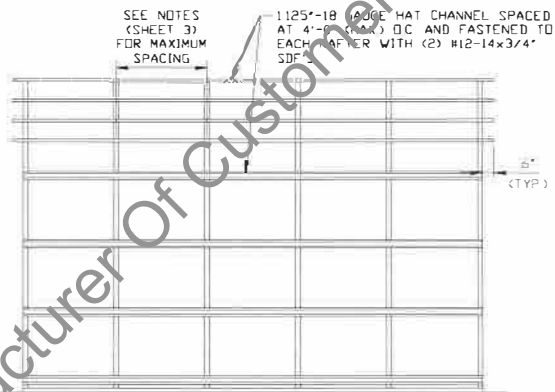

**TYPICAL FRAMING SECTION
VERTICAL ROOF OPTION**

SCALE: NTS

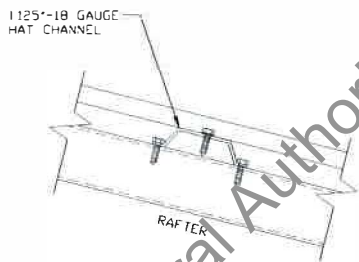

PANEL ATTACHMENT

(ALTER HERE FOR VERTICAL ROOF PANELS)
SCALE: NTS

**John Thomas
90 Reserve Drive
Fuquay Varina NC 27526**

CARPORT CENTRAL, INC.
737 SOUTH MAIN STREET
MOUNT AIRY, NC 27030
24'-0" x 17'-0" ENCLOSED STRUCTURE

**MOORE AND ASSOCIATES
ENGINEERING AND CONSULTING, INC.**

DRAWN BY: LT

CHECKED BY: PDH

PROJECT MGR: WSH

CLIENT: CC

DATE: 8-9-19

SHT. 16

SCALE: NTS

DWG. NO: SK-3

JOB NO: 191055

REV: 0

THIS DOCUMENT IS THE PROPERTY OF MOORE AND ASSOCIATES ENGINEERING AND CONSULTING. THE UNAUTHORIZED REPRODUCTION, COPYING, OR OTHERWISE USE OF THIS DOCUMENT IS STRICTLY PROHIBITED AND ANY INFRINGEMENT THEREUPON MAY BE SUBJECT TO LEGAL ACTION.