



Robert Brown
2590 Mclean Chapel Church Rd
Bunnlevel NC 28323

STRUCTURAL DESIGN

ENCLOSED BUILDING

**MAXIMUM 30'- 0" WIDE X 20'- 0" EAVE HEIGHT-
BOX EAVE FRAME AND BOW FRAME**

12 April 2019

Revision 0

M&A Project No. 18378S

Prepared for:

**Carport Central, Inc.
737 South Main Street
Mount Airy, NC 27030**

Prepared by:

Moore and Associates Engineering and Consulting, Inc.

**1009 East Avenue
North Augusta, SC 29841**

**401 S. Main Street, Suite 200
Mount Airy, NC 27030**



**MOORE AND ASSOCIATES
ENGINEERING AND CONSULTING**

**** CarportCentral Authorized Manufacturer Of Customer Use Only****

		<p>I HAVE RESEARCHED THIS CHAPTER AND THE LOUISIANA STATE UNIFORM CONSTRUCTION CODE AND TO THE BEST OF MY KNOWLEDGE AND BELIEF, THESE DRAWINGS ARE IN COMPLIANCE THEREWITH. I TAKE FULL RESPONSIBILITY FOR THE CONTENTS OF THESE PLANS.</p>	

**MOORE AND ASSOCIATES
ENGINEERING AND CONSULTING, INC.**

DRAWN BY: LT

CHECKED BY: PJM

PROJECT: MGR VSN

CLIENT: CC

**CARPOR CENTRAL, INC.
737 SOUTH MAIN STREET
MOUNT AIRY, NC 27030
30'-0" x 20'-0" ENCLOSED STRUCTURE**

DATE: 4-12-19

SHT. 1

SCALE: NTS

DWG. NO. SK-3

JOB NO. 18378S

REV. 0

THIS DOCUMENT IS THE PROPERTY OF MOORE AND ASSOCIATES ENGINEERS AND CONSULTANTS. THE UNAUTHORIZED REPRODUCTION, COPYING, OR OTHERWISE USE OF THIS DOCUMENT IS STRICTLY PROHIBITED AND ANY VIOLATION THEREOF MAY BE SUBJECT TO LEGAL ACTION.

		<p>WAYNE SHERIDAN MOORE No. 12395 4/12/19 REGISTERED PROFESSIONAL ENGINEER (STRUCTURAL)</p>	
	<p>Professional Certification I hereby certify that these documents were prepared or approved by me, and that I am a duly licensed professional engineer under the laws of the State of Maryland, License No. 49744, Expiration Date <u>6/6/20</u></p>		

**MOORE AND ASSOCIATES
ENGINEERING AND CONSULTING, INC.**

DRAWN BY: LT
CHECKED BY: PJM

CARPOT CENTRAL, INC.
737 SOUTH MAIN STREET
MOUNT AIRY, NC 27030
30'-0" x 20'-0" ENCLOSED STRUCTURE

THIS DOCUMENT IS THE PROPERTY OF MOORE AND ASSOCIATES ENGINEERING AND CONSULTING, INC. UNAUTHORIZED REPRODUCTION, COPIING, OR OTHERWISE USE OF THIS DOCUMENT IS STRICTLY PROHIBITED AND ANY VIOLATION THEREOF MAY BE SUBJECT TO LEGAL ACTION.

PROJECT: NBR V3H
CLIENT: CC
DATE: 4-12-19
SHT. 1A
SCALE: NTS
DWG. NO: SK-3
REV: 0

INSTALLATION NOTES AND SPECIFICATIONS

1. DESIGN IS FOR MAXIMUM 30'-0" WIDE x 20'-0" EAVE HEIGHT ENCLOSED STRUCTURES.
2. DESIGN WAS DONE IN ACCORDANCE WITH THE 2018 NORTH CAROLINA BUILDING CODE, 2017 FLORIDA BUILDING CODE (FBC) 6TH EDITION, 2018 INTERNATIONAL BUILDING CODE (IBC), 2006 IBC, 2009 IBC, 2012 IBC, 2015 IBC, AND 2018 IBC.
3. DESIGN LOADS ARE AS FOLLOWS:
 - A) DEAD LOAD = 1.5 PSF
 - B) LIVE LOAD = 12 PSF
 - C) GROUND SNOW LOAD = 33 PSF AT 5'-0" O.C. SPACING
= 42 PSF AT 4'-0" O.C. SPACING.
30 PSF (WITH U-CHANNEL PEAK BRACE) W ≤ 26'-0"
(UNBALANCED SNOW LOADS DUE TO DRIFTING HAVE NOT BEEN EVALUATED.)
4. ULTIMATE WIND SPEED 105 TO 143 MPH (NOMINAL WIND SPEED 82 TO 110 MPH)
MAXIMUM RAFTER/COLUMN AND END COLUMN SPACING = 5.0 FEET
5. ULTIMATE WIND SPEED 144 TO 155 MPH (NOMINAL WIND SPEED 111 TO 120 MPH).
MAXIMUM RAFTER/COLUMN AND END COLUMN SPACING = 4.0 FEET
6. END WALL COLUMNS (POSTS) ARE SIMILAR TO SIDE WALL POSTS IN SIZE AND SPACING UNLESS NOTED OTHERWISE.
7. LOW HAZARD RISK CATEGORY I.
8. WIND EXPOSURE CATEGORY B.
9. SPECIFICATIONS APPLICABLE TO 29 GAUGE METAL PANELS FASTENED DIRECTLY TO 2 1/4" x 2 1/4" - 14 GAUGE TUBE STEEL (TS) FRAMING MEMBERS (UNLESS NOTED OTHERWISE).
10. AVERAGE FASTENER SPACING ON-CENTERS ALONG RAFTERS OR HAT CHANNELS, AND COLUMNS (INTERIOR OR END) = 8 INCHES.
11. FASTENERS CONSIST OF #12-14x3/4" (UNLESS OTHERWISE NOTED) SELF-DRILLING FASTENER (SDF), USE CONTROL SEAL WASHER WITH EXTERIOR FASTENERS. SPECIFICATIONS APPLICABLE ONLY FOR MEAN ROOF HEIGHT OF 20 FEET OR LESS. END ROOF SLOPES OF 14" (3:12) PITCH OR LESS SPACING REQUIREMENTS FOR OTHER ROOF HEIGHTS AND/OR SLOPES MAY VARY.
12. ANCHORS SHALL BE INSTALLED THROUGH BASE RAIL WITHIN 6' OF EACH COLUMN
13. STANDARD GROUND ANCHORS (SOIL NAILS) CONSIST OF #4 REBAR W/ WELDED NUT x 36" LONG. SOIL NAILS MAY BE USED FOR MAXIMUM WIND V = 145 MPH AND IN SUITABLE SOIL CONDITIONS. OPTIONAL ANCHORAGE MAY BE USED IN SUITABLE SOILS AND MUST BE USED FOR WIND V > 145 MPH AND/OR IN UNSUITABLE SOILS AS NOTED
14. WIND FORCES GOVERN OVER SEISMIC FORCES. SEISMIC PARAMETERS ANALYZED ARE:
SOIL SITE CLASS = D
RISK CATEGORY I/II/III
R= 3.25 I_e= 1.0
S_{es}= 2.039 g V= C_sW
S_m= 1.258 g
15. DOOR AND WINDOW PRESSURES APPLICABLE TO THE STATE OF FLORIDA.

** CarportCentral Authorized Manufacturer Of Customer Use Only**

**MOORE AND ASSOCIATES
ENGINEERING AND CONSULTING, INC.**

DRAWN BY: LT

CHECKED BY: PSH

PROJECT NO: VSM

CLIENT: CC

CARPORT CENTRAL, INC.
737 SOUTH MAIN STREET
MOUNT AIRY, NC 27030
30'-0"x20'-0" ENCLOSED STRUCTURE

DATE: 4-12-19

SCALE: NTS

JOB NO: 183785

SHT. 3

FIG. NO: SK-3

REV: 0

THIS DOCUMENT IS THE PROPERTY OF MOORE AND ASSOCIATES ENGINEERING AND CONSULTING. THE UNAUTHORIZED REPRODUCTION, COPYING, OR OTHERWISE USE OF THIS DOCUMENT IS STRICTLY PROHIBITED AND ANY VIOLATION THEREOF MAY BE SUBJECT TO LEGAL ACTION.

BOX EAVE FRAME RAFTER STRUCTURE

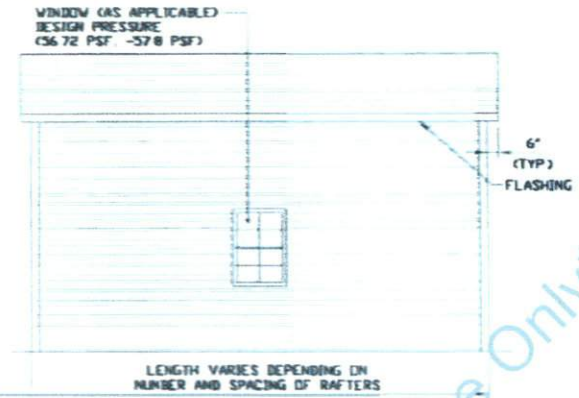
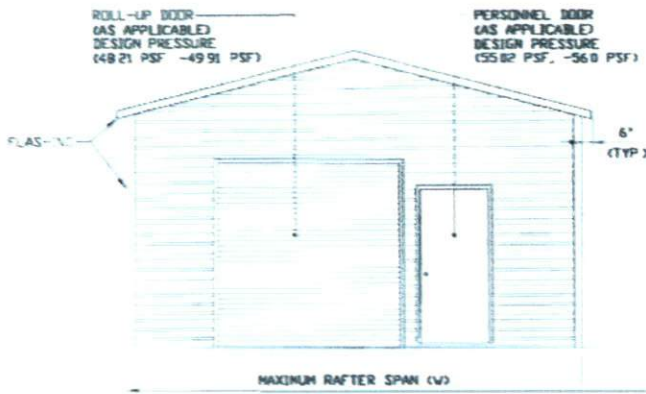

TYPICAL END ELEVATION-HORIZONTAL ROOF

TYPICAL SIDE ELEVATION-HORIZONTAL ROOF

SCALE: NTS

SCALE: NTS

BOW FRAME RAFTER STRUCTURE

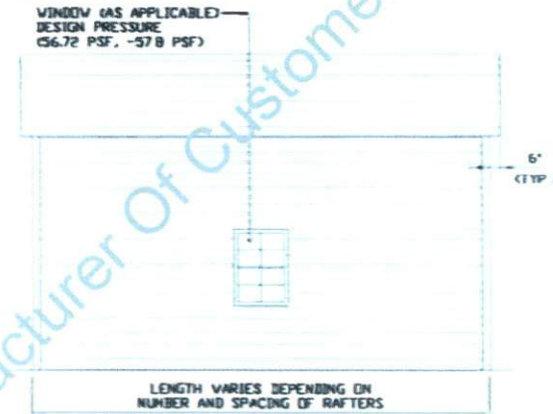
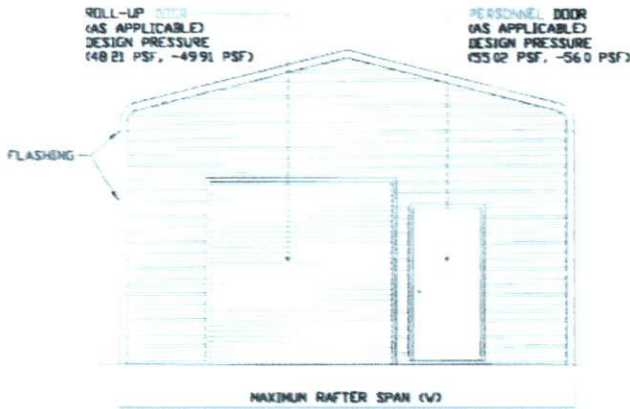

TYPICAL END ELEVATION
SCALE: NTS

TYPICAL END ELEVATION
SCALE: NTS

**MOORE AND ASSOCIATES
ENGINEERING AND CONSULTING, INC.**

DRAWN BY: LT

CHECKED BY: PJM

PROJECT NO: VSH

CLIENT: CC

CARPORT CENTRAL, INC.
737 SOUTH MAIN STREET
MOUNT AIRY, NC 27030
30'-0" x 20'-0" ENCLOSED STRUCTURE

DATE: 4-12-19

SHT. 3A

SCALE: NTS

DWG. NO: SK-3

JOB NO: 18378S

REV: 0

THIS DOCUMENT IS THE PROPERTY OF MOORE AND ASSOCIATES ENGINEERING AND CONSULTING, INC. UNAUTHORIZED REPRODUCTION, COPYING, OR OTHERWISE USE OF THIS DOCUMENT IS STRICTLY PROHIBITED AND ANY VIOLATION THEREOF MAY BE SUBJECT TO LEGAL ACTION.

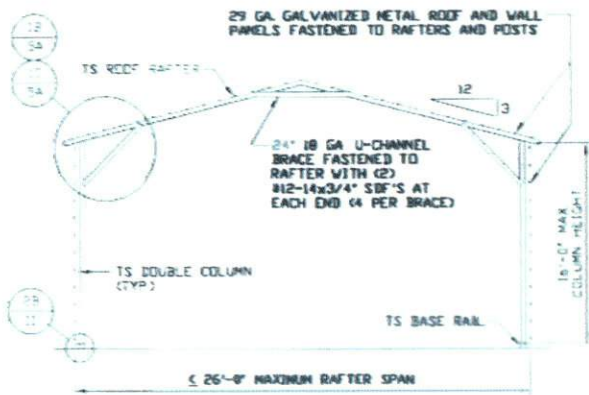

TYPICAL RAFTER/COLUMN END FRAME SECTION
SCALE: NTS

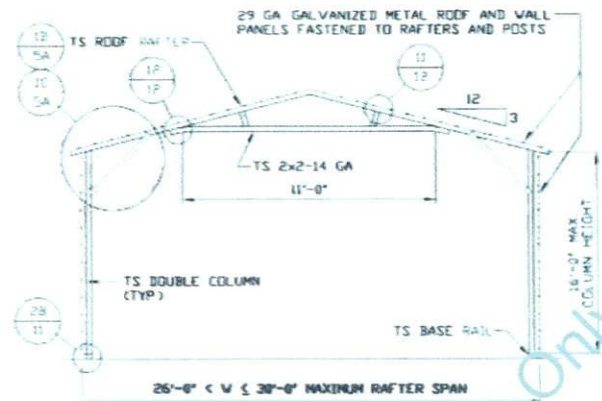

TYPICAL RAFTER/COLUMN END FRAME SECTION
SCALE: NTS

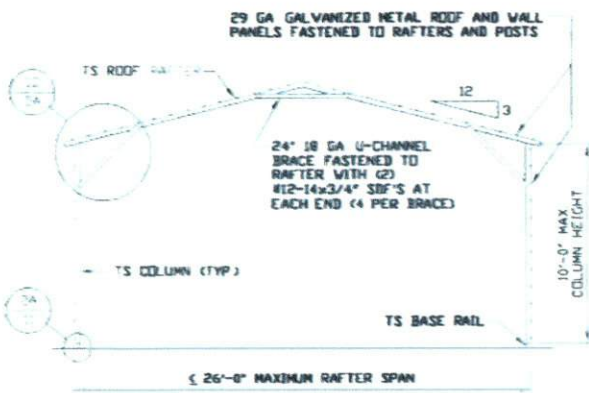

TYPICAL RAFTER/COLUMN END FRAME SECTION
SCALE: NTS

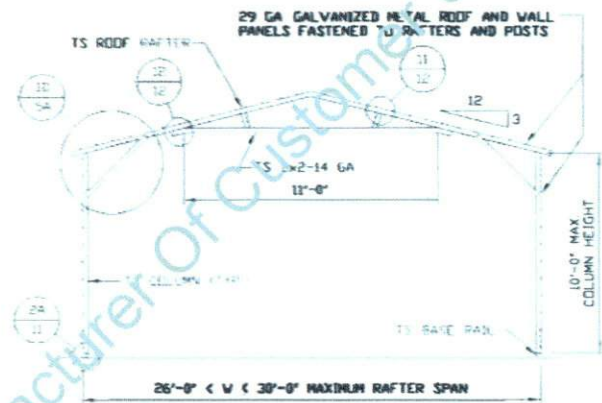

TYPICAL RAFTER/COLUMN END FRAME SECTION
SCALE: NTS

SEE NOTES
CSHEET 30
FOR MAXIMUM
SPACING

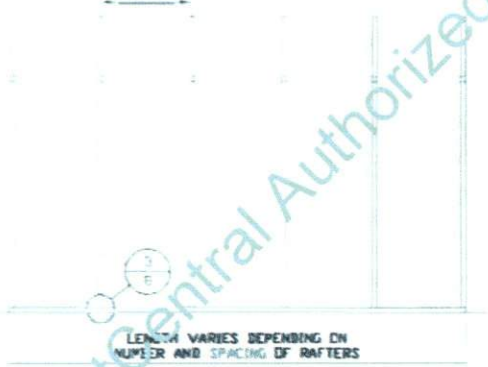

TYPICAL RAFTER/COLUMN SIDE FRAMING SECTION
SCALE: NTS

**MOORE AND ASSOCIATES
ENGINEERING AND CONSULTING, INC.**

DRAWN BY: LT

CHECKED BY: PJM

PROJECT NO: VSM

CLIENT: CC

CARPOT CENTRAL, INC.
737 SOUTH MAIN STREET
MOUNT AIRY, NC 27030
30'-0"x20'-0" ENCLOSED STRUCTURE

DATE: 4-12-19

SHT. 4A

SCALE: NTS

DWG. NO: SK-3

JOB NO: 18378S

REV: 0

THIS DOCUMENT IS THE PROPERTY OF MOORE AND ASSOCIATES ENGINEERING AND CONSULTING, INC. UNAUTHORIZED REPRODUCTION, COPYING, OR OTHERWISE USE OF THIS DOCUMENT IS STRICTLY PROHIBITED AND ANY INFRINGEMENT THEREUPON MAY BE SUBJECT TO LEGAL ACTION.

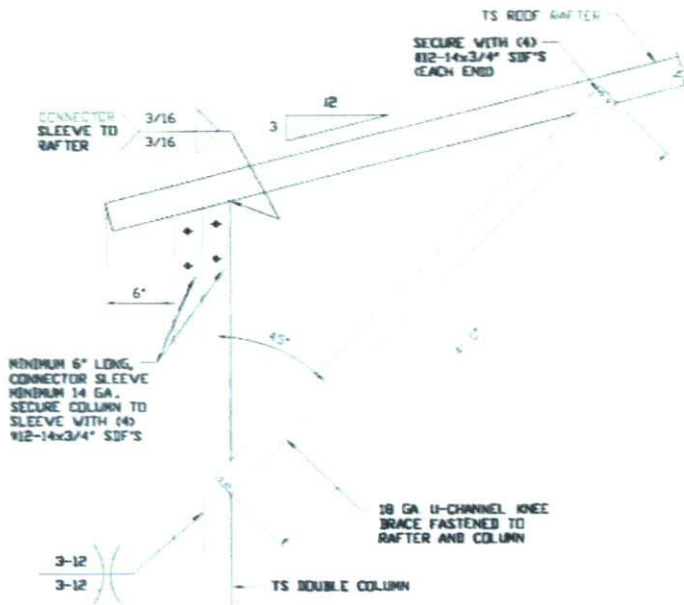

1B
BOX EAVE RAFTER COLUMN CONNECTION DETAIL FOR HEIGHTS 12'-0" < TO ≤ 16'-0"
SCALE: NTS

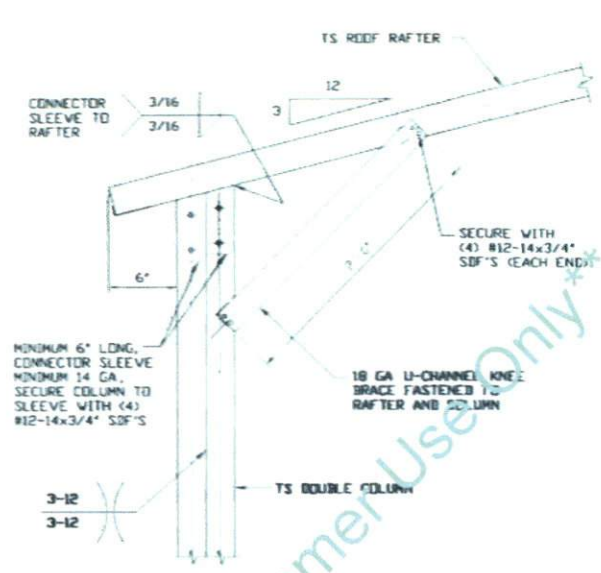

1C
BOX EAVE RAFTER COLUMN CONNECTION DETAIL FOR HEIGHTS 10'-0" < TO ≤ 12'-0"
SCALE: NTS

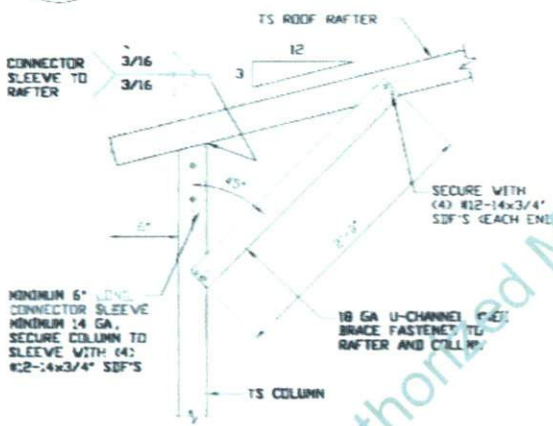

1D
BOX EAVE RAFTER COLUMN CONNECTION DETAIL FOR HEIGHTS ≤ 10'-0"
SCALE: NTS

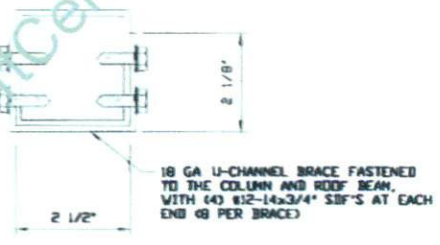

BRACE SECTION
SCALE: NTS

MOORE AND ASSOCIATES ENGINEERING AND CONSULTING, INC.

DRAWN BY: LT
CHECKED BY: PPH

CARPOT CENTRAL, INC.
737 SOUTH MAIN STREET
MOUNT AIRY, NC 27030
30'-0" x 20'-0" ENCLOSED STRUCTURE

PROJECT MGR: WSH **DATE: 4-12-19** **SCALE: NTS** **JOB NO: 18378S**
CLIENT: CC **SHT: 5A** **DWG. NO: SK-3** **REV: 0**

THIS DOCUMENT IS THE PROPERTY OF MOORE AND ASSOCIATES ENGINEERS AND CONSULTING. THE UNAUTHORIZED REPRODUCTION, COPYING, OR OTHERWISE USE OF THIS DOCUMENT IS STRICTLY PROHIBITED AND ANY INFRINGEMENT THEREUPON MAY BE SUBJECT TO LEGAL ACTION.

BASE RAIL ANCHORAGE OPTIONS

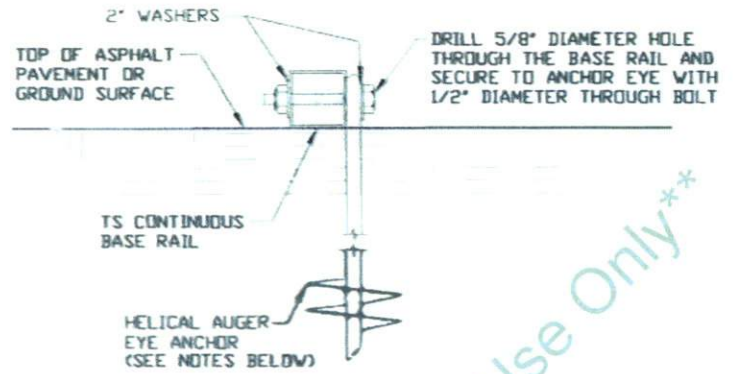
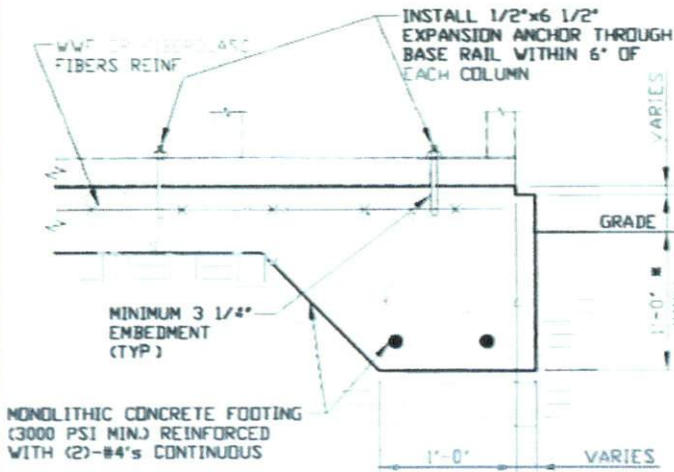

3A

CONCRETE MONOLITHIC SLAB BASE RAIL ANCHORAGE

SCALE: NTS
MINIMUM ANCHOR EDGE DISTANCE IS 4\"/>

3B

HELICAL AUGER ANCHORAGE

SCALE: NTS (CAN BE USED FOR ASPHALT)

GENERAL NOTES

NOTE: CONCRETE MONOLITHIC SLAB DESIGN BASED ON MINIMUM SOIL BEARING CAPACITY OF 1,500 PSF.

CONCRETE:

CONCRETE SHALL HAVE A MINIMUM SPECIFIED COMPRESSIVE STRENGTH OF 3,000 PSI AT 28 DAYS.

COVER OVER REINFORCING STEEL:

FOR FOUNDATIONS, MINIMUM CONCRETE COVER OVER REINFORCING BARS SHALL BE PER ACI-318:
3" IN FOUNDATIONS WHERE THE CONCRETE IS CAST AGAINST AND PERMANENTLY IN CONTACT WITH THE EARTH OR EXPOSED TO THE EARTH OR WEATHER, AND 1 1/2" ELSEWHERE.

REINFORCING STEEL:

THE TURNDOWN REINFORCING STEEL SHALL BE ASTM A615 GRADE 60 THE SLAB REINFORCEMENT SHALL BE WELDED WIRE FABRIC MEETING ASTM A185 OR FIBERGLASS FIBER REINFORCEMENT.

REINFORCEMENT MAY BE BENT IN THE SHOP OR THE FIELD PROVIDED:

- 1 REINFORCEMENT IS BENT COLD.
- 2 THE DIAMETER OF THE BEND, MEASURED ON THE INSIDE OF THE BAR, IS NOT LESS THAN SIX-BAR DIAMETER.
- 3 REINFORCEMENT PARTIALLY EMBEDDED IN CONCRETE SHALL NOT BE FIELD BENT.

HELICAL AUGER ANCHOR NOTES:

- 1 FOR VERY DENSE AND/OR CEMENTED SANDS, COARSE GRAVEL AND COBBLES, CALICHE, PRELTAPE, SILTS AND CLAYS, USE MINIMUM (2) 4" HELICES WITH MINIMUM 30" EMBEDMENT OR SINGLE 6" HELIX WITH MINIMUM 50" EMBEDMENT.
- 2 FOR CORAL USE MINIMUM (2) 4" HELICES WITH MINIMUM 30" EMBEDMENT OR SINGLE 6" HELIX WITH MINIMUM 50" EMBEDMENT.
- 3 FOR MEDIUM DENSE COARSE SANDS, SANDY GRAVELS, VERY STIFF SILTS, AND CLAYS USE MINIMUM (2) 4" HELICES WITH MINIMUM 30" EMBEDMENT OR SINGLE 6" HELIX WITH MINIMUM 50" EMBEDMENT.
- 4 FOR LOOSE TO MEDIUM DENSE SANDS, FIRM TO STIFF CLAYS AND SILTS ALLUVIAL FILL, USE MINIMUM (2) 6" HELICES WITH MINIMUM 50" EMBEDMENT.
- 5 FOR VERY LOOSE TO MEDIUM DENSE SANDS, FIRM TO STIFFER CLAYS AND SILTS, ALLUVIAL FILL, USE MINIMUM (2) 8" HELICES WITH MINIMUM 60" EMBEDMENT.

MOORE AND ASSOCIATES
ENGINEERING AND CONSULTING, INC.

DRAWN BY: LT

CHECKED BY: PDM

PROJECT NO: VSM

CLIENT: CC

CARPORT CENTRAL, INC.
737 SOUTH MAIN STREET
MOUNT AIRY, NC 27030
30'-0" x 20'-0" ENCLOSED STRUCTURE

DATE: 4-12-19

SHT. 8

SCALE: NTS

DWG. NO: SK-3

JOB NO: 18378S

REV: 0

THIS DOCUMENT IS THE PROPERTY OF MOORE AND ASSOCIATES ENGINEERING AND CONSULTING. THE UNAUTHORIZED REPRODUCTION, COPYING, OR OTHERWISE USE OF THIS DOCUMENT IS STRICTLY PROHIBITED AND ANY IMPROPERMENT THEREOF MAY BE SUBJECT TO LEGAL ACTION.

BASE RAIL ANCHORAGE OPTIONS

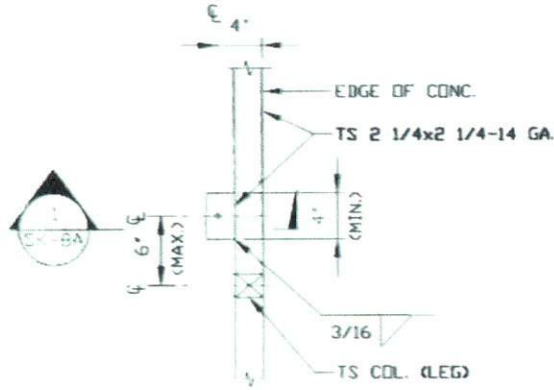

TYPICAL ANCHOR DETAIL WHEN BASE RAIL IS NEAR EDGE OF CONCRETE
SCALE: NTS

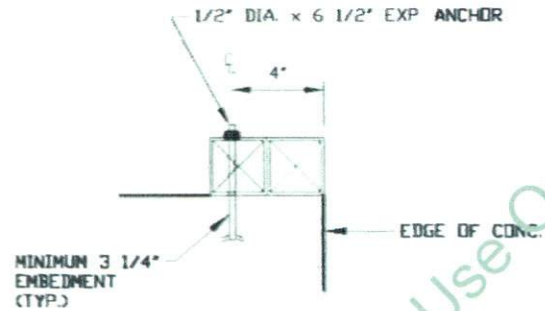

SECTION
SCALE: NTS

*** CarportCentral Authorized Manufacturer Of Customer Use Only***

**MOORE AND ASSOCIATES
ENGINEERING AND CONSULTING, INC.**

DRAWN BY: LT

CHECKED BY: PBM

PROJECT MGR: VSM

CLIENT: CC

CARPORT CENTRAL, INC.
737 SOUTH MAIN STREET
MOUNT AIRY, NC 27030
30'-0" x 20'-0" ENCLOSED STRUCTURE

DATE: 4-12-19

SCALE: NTS

JOB NO: 18378S

SHT. 8A

DWG. NO: SK-3

REV: 0

THIS DOCUMENT IS THE PROPERTY OF MOORE AND ASSOCIATES ENGINEERING AND CONSULTING. THE UNAUTHORIZED REPRODUCTION, COPYING, OR OTHERWISE USE OF THIS DOCUMENT IS STRICTLY PROHIBITED AND ANY INFRINGEMENT THEREUPON MAY BE SUBJECT TO LEGAL ACTION.

BOX EAVE RAFTER END WALL AND SIDE WALL OPENINGS

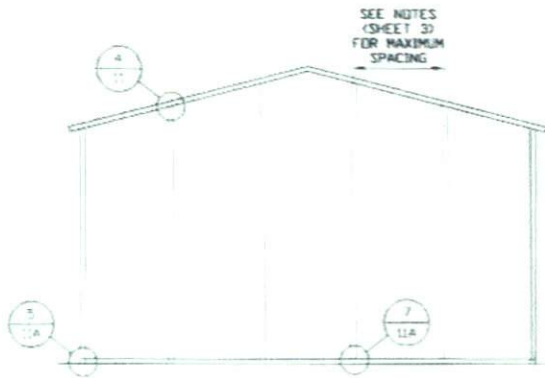

**TYPICAL BOX EAVE RAFTER
END WALL FRAMING SECTION**

SCALE: NTS

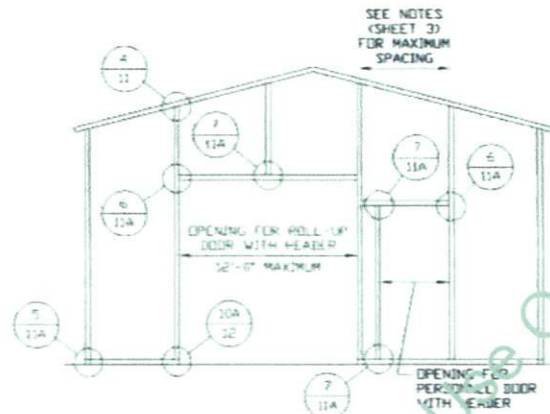

**TYPICAL BOX EAVE RAFTER END
WALL OPENINGS FRAMING SECTION**

SCALE: NTS

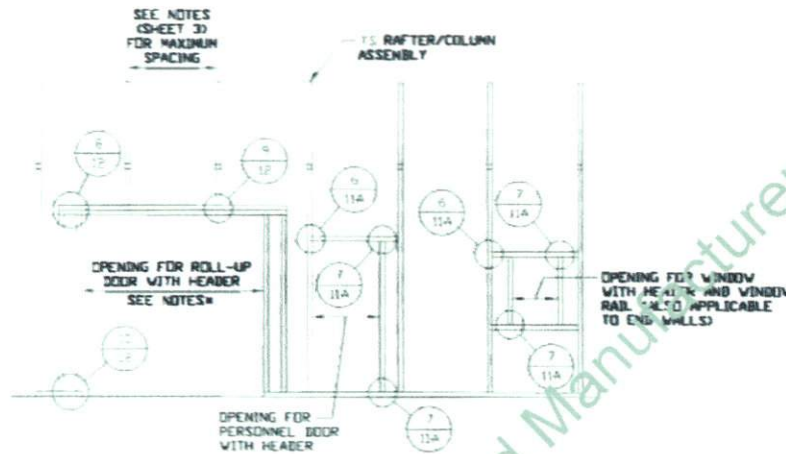

**TYPICAL BOX EAVE RAFTER
SIDE WALL OPENINGS FRAMING SECTION**

SCALE: NTS

- NOTES:
- * 10'-0" MAX. FOR 5'-0" O.C. RAFTER/COLUMN SPACING.
 - * 9'-0" MAX. FOR 4'-0" O.C. RAFTER/COLUMN SPACING.

** CarportCentral Authorized Manufacturer Of Custom Use Only**

**MOORE AND ASSOCIATES
ENGINEERING AND CONSULTING, INC.**

DRAWN BY: LT		CARPORT CENTRAL, INC. 737 SOUTH MAIN STREET MOUNT AIRY, NC 27030 30'-0" x 20'-0" ENCLOSED STRUCTURE	
CHECKED BY: PJH			
PROJECT NGR: VSN	DATE: 4-12-19	SCALE: NTS	JOB NO: 18378S
CLIENT: CC	SHT. 9	DWG. NO: SK-3	REV: 0

THIS DOCUMENT IS THE PROPERTY OF MOORE AND ASSOCIATES ENGINEERING AND CONSULTING. THE UNAUTHORIZED REPRODUCTION, COPYING, OR OTHERWISE USE OF THIS DOCUMENT IS STRICTLY PROHIBITED AND ANY INFRACTION THEREUPON MAY BE SUBJECT TO LEGAL ACTION.

CONNECTION DETAILS

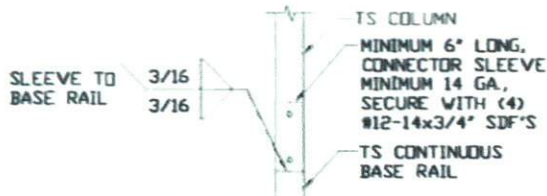

2A RAFTER COLUMN/BASE RAIL CONNECTION DETAIL
SCALE: NTS



2B RAFTER COLUMN/BASE RAIL CONNECTION DETAIL
SCALE: NTS

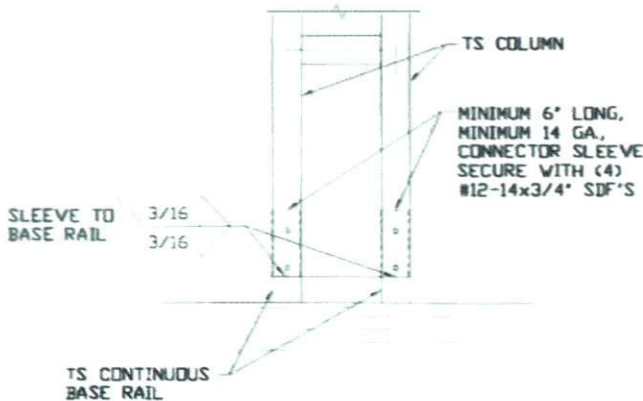

2C RAFTER COLUMN/BASE RAIL CONNECTION DETAIL
SCALE: NTS

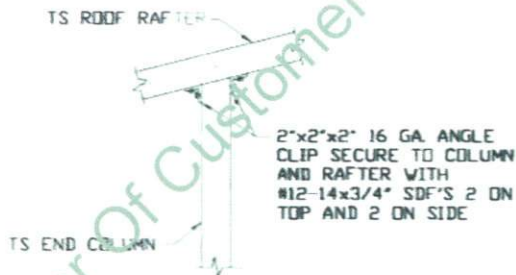

4 END COLUMN/RAFTER CONNECTION DETAIL
SCALE: NTS

*** CarportCentral Authorized Manufacturer Of Customer Use Only***

**MOORE AND ASSOCIATES
ENGINEERING AND CONSULTING, INC.**

DRAWN BY: LT

CHECKED BY: PJM

PROJECT MGR: WSM

CLIENT: CC

CARPORT CENTRAL, INC.
737 SOUTH MAIN STREET
MOUNT AIRY, NC 27030
30'-0" x 20'-0" ENCLOSED STRUCTURE

DATE: 4-12-19

SCALE: NTS

JOB NO: 18378S

SHT. 11

DWG. NO: SK-3

REV: 0

THIS DOCUMENT IS THE PROPERTY OF MOORE AND ASSOCIATES ENGINEERING AND CONSULTING. THE UNAUTHORIZED REPRODUCTION, COPYING, OR OTHERWISE USE OF THIS DOCUMENT IS STRICTLY PROHIBITED AND ANY INFRINGEMENT THEREUPON MAY BE SUBJECT TO LEGAL ACTION.

CONNECTION DETAILS

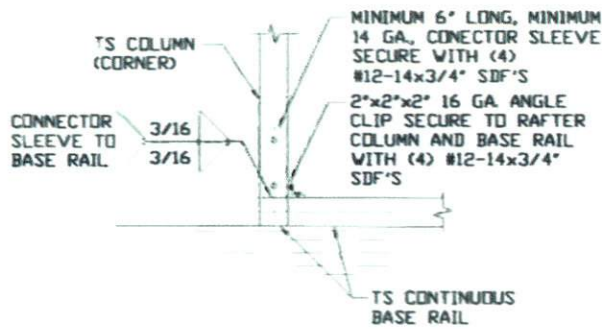

5

END COLUMN/BASE RAIL CONNECTION DETAIL

SCALE: NTS

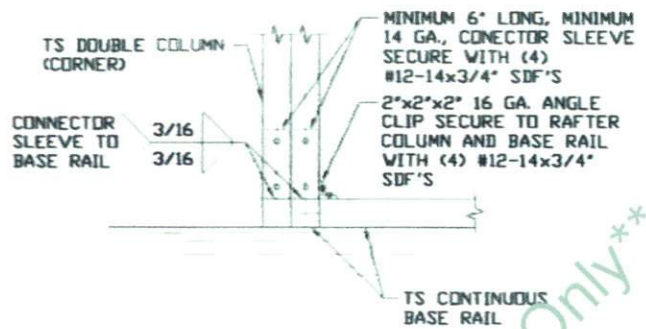

5A

END COLUMN/BASE RAIL CONNECTION DETAIL

SCALE: NTS

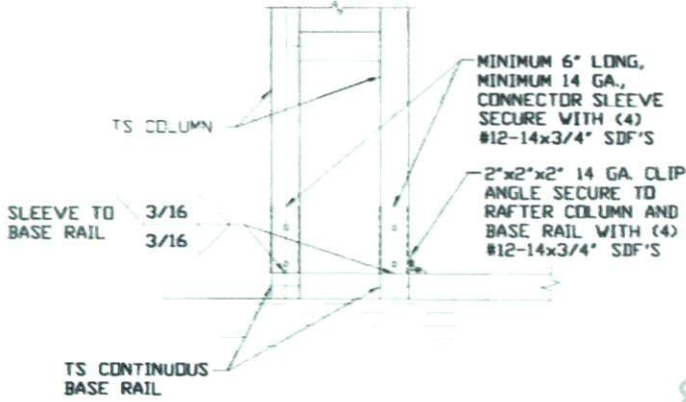

5B

END COLUMN/BASE RAIL CONNECTION DETAIL

SCALE: NTS

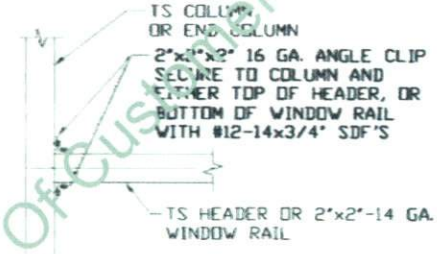

6

COLUMN OR WINDOW RAIL TO POST CONNECTION DETAIL

SCALE: NTS

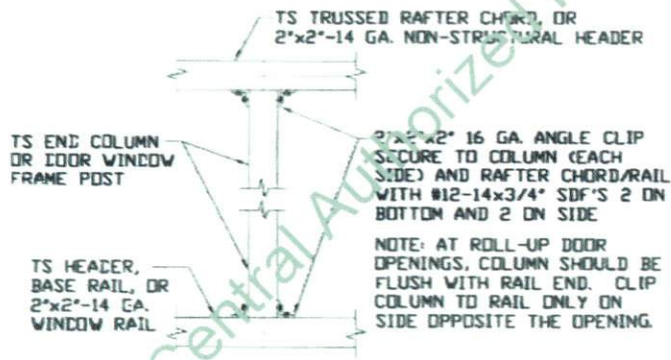

7

COLUMN TO HEADER, BASE RAIL, OR WINDOW RAIL CONNECTION DETAIL

SCALE: NTS

MOORE AND ASSOCIATES ENGINEERING AND CONSULTING, INC.

DRAWN BY: LY
CHECKED BY: PBM

CARPORT CENTRAL, INC.
737 SOUTH MAIN STREET
MOUNT AIRY, NC 27030
30'-0"x20'-0" ENCLOSED STRUCTURE

THIS DOCUMENT IS THE PROPERTY OF MOORE AND ASSOCIATES ENGINEERING AND CONSULTING. THE UNAUTHORIZED REPRODUCTION, COPYING, OR OTHERWISE USE OF THIS DOCUMENT IS STRICTLY PROHIBITED AND ANY VIOLATION THEREOF MAY BE SUBJECT TO LEGAL ACTION.

PROJECT MGR: VSM	DATE: 4-12-19	SCALE: NTS	JOB NO: 19378S
CLIENT: CC	SHT. 11A	DWG. NO: SK-3	REV: 0

CONNECTION DETAILS

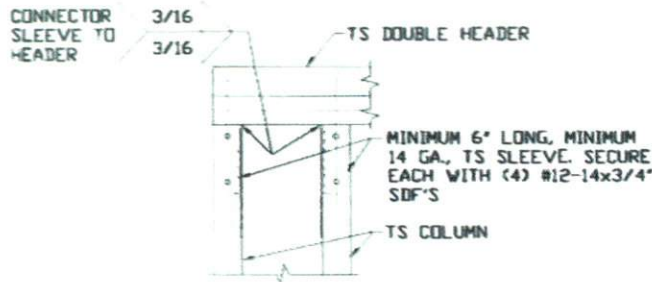

8
DOUBLE HEADER/COLUMN CONNECTION DETAIL
SCALE: NTS

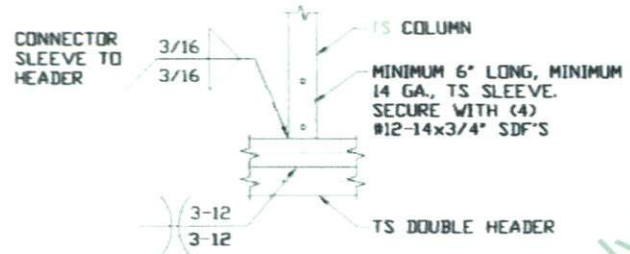

9
COLUMN/DOUBLE HEADER CONNECTION DETAIL
SCALE: NTS

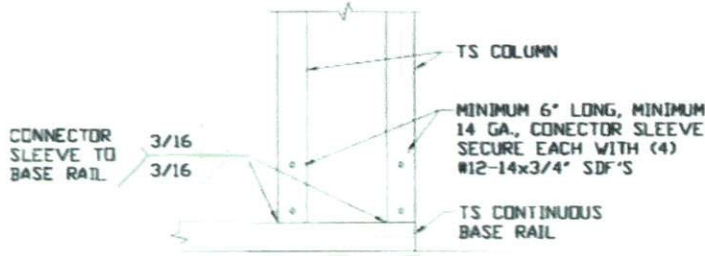

10
COLUMN/BASE RAIL CONNECTION DETAIL
SCALE: NTS

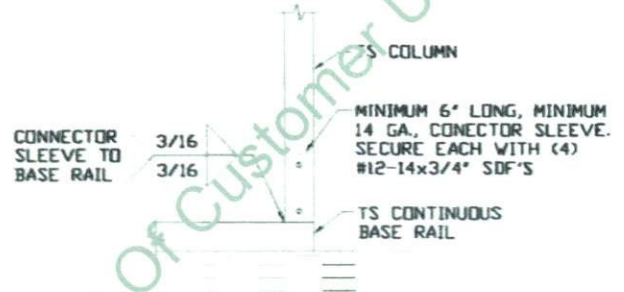

10A
COLUMN/BASE RAIL CONNECTION DETAIL
SCALE: NTS

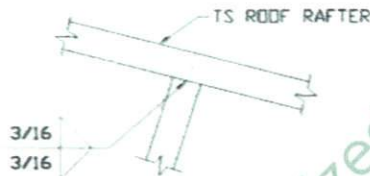

11
RAFTER TO CHORD CONNECTION DETAIL
SCALE: NTS

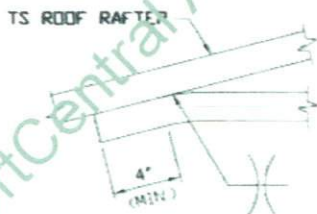

12
COLLAR TIE CONNECTION DETAIL
SCALE: NTS

**MOORE AND ASSOCIATES
ENGINEERING AND CONSULTING, INC.**

DRAWN BY: LT
CHECKED BY: PBN

CARPORT CENTRAL, INC.
737 SOUTH MAIN STREET
MOUNT AIRY, NC 27030
30'-0" x 20'-0" ENCLOSED STRUCTURE

PROJECT NO: VSM	DATE: 4-12-19	SCALE: NTS	JOB NO: 18378S
CLIENT: CC	SHT. 12	DWG. NO: SK-3	REV.: 0

THIS DOCUMENT IS THE PROPERTY OF MOORE AND ASSOCIATES ENGINEERING AND CONSULTING. THE UNAUTHORIZED REPRODUCTION, COPYING, OR OTHERWISE USE OF THIS DOCUMENT IS STRICTLY PROHIBITED AND ANY VIOLATION THEREOF MAY BE SUBJECT TO LEGAL ACTION.