

BUILDER SHALL VERIFY ALL DIMENSIONS AND CONDITIONS AT TIME OF CONSTRUCTION.

ALL CONSTRUCTION SHALL CONFORM TO THE 2018 EDITION OF THE NC STATE BUILDING CODE, CODES GOVERN OVER DRAWINGS, DIMENSIONS GOVERN OVER SCALE.

VERIFY ALL MECHANICAL REQUIREMENTS BEFORE FRAMING.

YUNCANNON DESIGNS DOES NOT ASSUME LIABILITY FOR ANY DEVIATION OF OR CONSTRUCTION METHODS OF THESE PLANS.

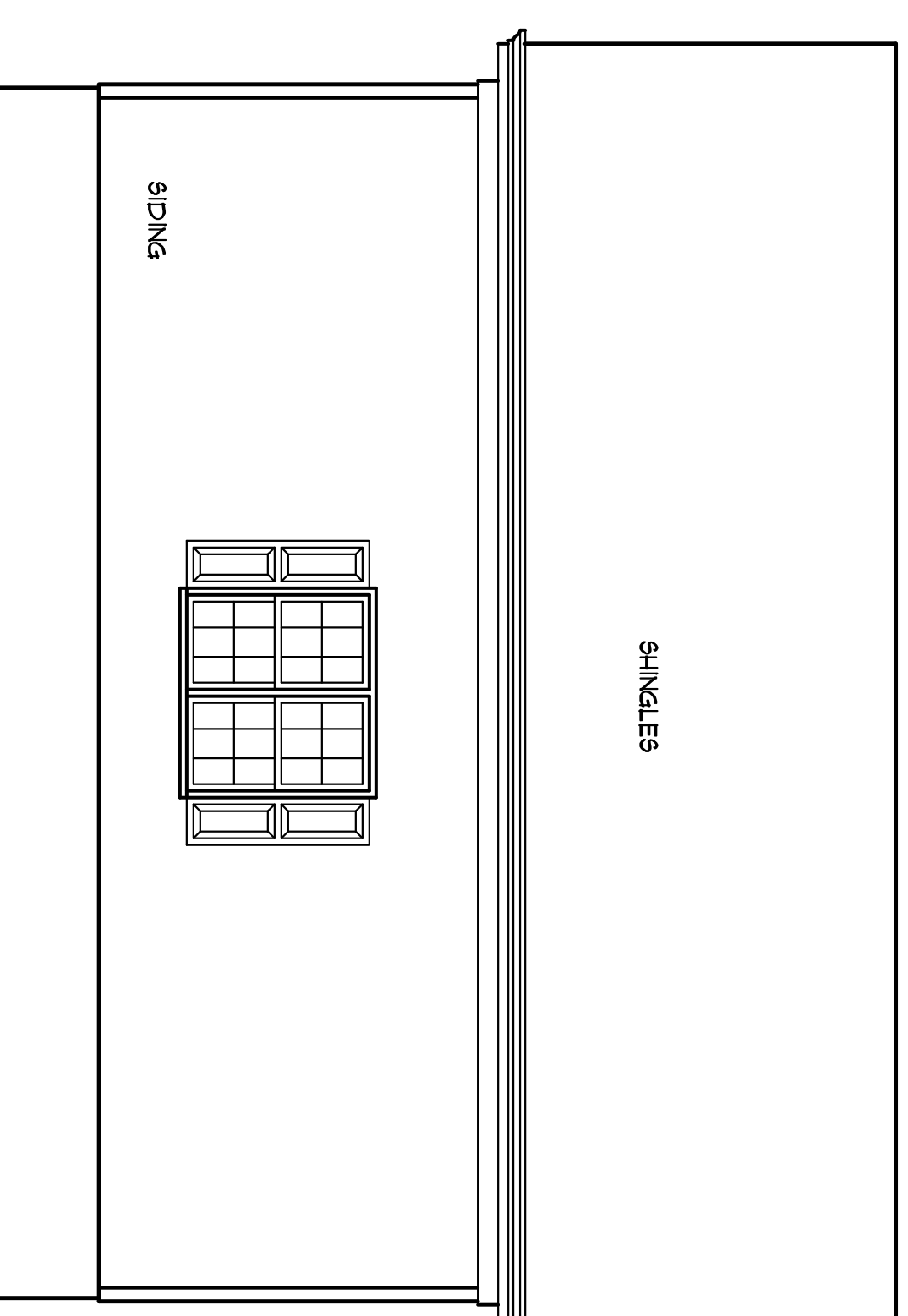
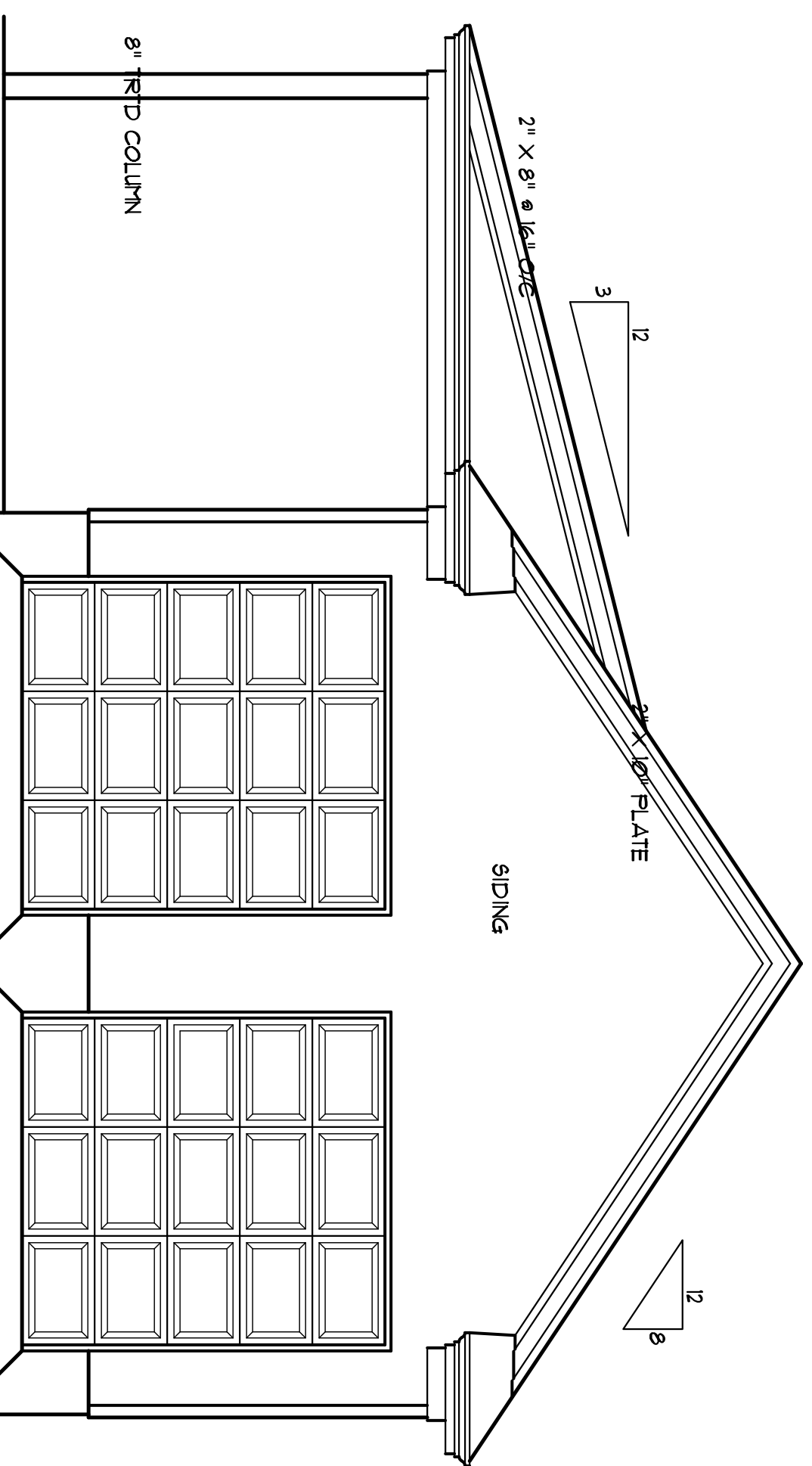

ELEVATIONS

SCALE: 1/4" = 1'-0"

FOUNDATION NOTES

- 1) SPECIFIC NOTES ON THE PLANS TAKE PRECEDENCE OVER THE FOLLOWING GENERAL NOTES. IN THE EVENT OF A CONFLICT, THE MORE SPECIFIC NOTES SHALL GOVERN AND CONTRACTOR SHALL BE SOLELY RESPONSIBLE FOR DIRECTIONAL ACCURACY. ALL CONSTRUCTION TO MEET CURRENT REGULATIONS.
- 2) STRUCTURAL CONCRETE TO BE PER 3020 PER PRE-STANDARD 318, ACCORDANCE WITH ALL.
- 3) FOOTINGS TO BE ON UNDISTURBED EARTH. ALL OTHERS TO BE DIRECTED BY THE LOCAL INSPECTOR.
- 4) FOOTING SIZES BASED ON A REPRESENTATIVE SOIL BEARING CAPACITY OF 2000 PSF. CONTRACTOR IS SOLELY RESPONSIBLE FOR VERIFYING THE TYPE OF CONSTRUCTION.
- 5) FOOTINGS AND PIERS SHALL BE CENTERED UNDER FOUNDATION. FOUNDATION SHALL BE MASONRY, HEAVY PROTECTIVE FINISH OR MASONRY.
- 6) MAXIMUM DEPTH OF DEWATERED FILL AGAINST THE VI SECTION R-3043 OF THE NC STATE CODE.

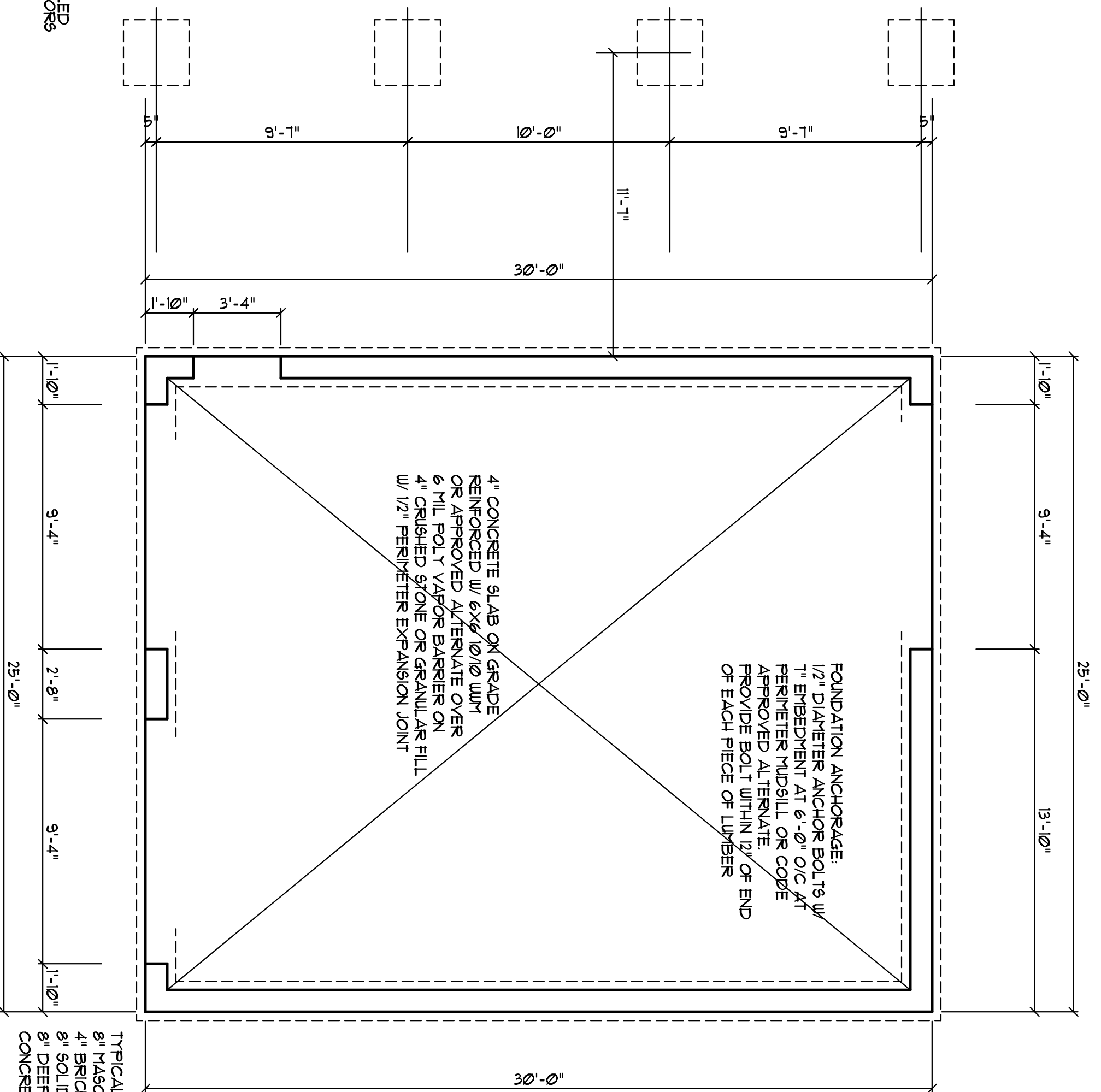

COLUMN DETAIL

SCALE: 1/4" = 1'-0"

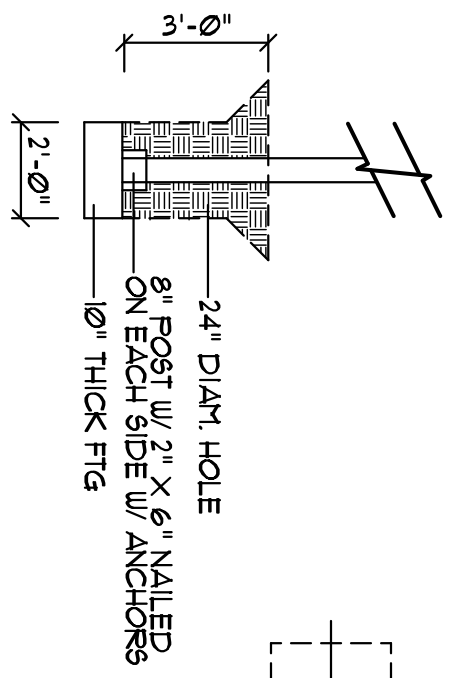

ATTIC SPACE VENTILATION

MAIN ROOF ATTIC AREA = 190 SQ. FT.
REQUIRED AREA = A/200 = 290 SQ. FT.

NOTE: ALL EAVES TO HAVE 2" CONTINUOUS SOFFIT VENT. ALLOW 1" AIR SPACE ABOVE INSULATION FOR AIR FLOW.

BRACED WALL NOTES:

1. BRACED WALLS ARE REQUIRED PER SECTION R602.10.1 2018 NBC RESIDENTIAL CODE.
2. THE EXTERIOR WALL STRUCTURE SHALL BE CONTINUOUSLY SHEATHED FULL HEIGHT WITH MINIMUM THICKNESS 7/16" OSB. THESE WALLS SHALL BE CONSTRUCTED IN CONFORMANCE TO THE OSB-NSP DETAILS.
3. BASIS OF DESIGN FOR INTERIOR BRACE WALLS IS LB (LET IN BRACING) METHOD AS DENIED PER CODE TABLE R602.10.2.
4. SPECIAL BRACING DETAILS ARE ILLUSTRATED IN THE CODE AND ALLOWED WHERE WALLS DO NOT MEET THE MINIMUM REQUIREMENTS FOR SUPPORT. REFER TO GARAGE DETAILS, FINISH TRIMMING DETAILS.

FRAMING NOTES

- 1) ALL FRAMING LUMBER SPEC #2 GRADE (NLSA) OR BETTER UNLESS NOTED.
- 2) JOIST SIZE AND SPACING BASED ON CODE MINIMUMS. BUILDER SHOULD CONSIDER SHEATHING FLOOR SYSTEM IN LONG SPAN AREAS TO REDUCE FLOOR FLEXIBILITY.
- 3) PROVIDE DOUBLE JOIST UNDER WALLS PARALLEL TO JOIST DIRECTION.
- 4) PROVIDE SOLID BLOCKING BETWEEN ALL POINT LOADS AND TOP OF GIRDER PIER OR FOUNDATION WALL.

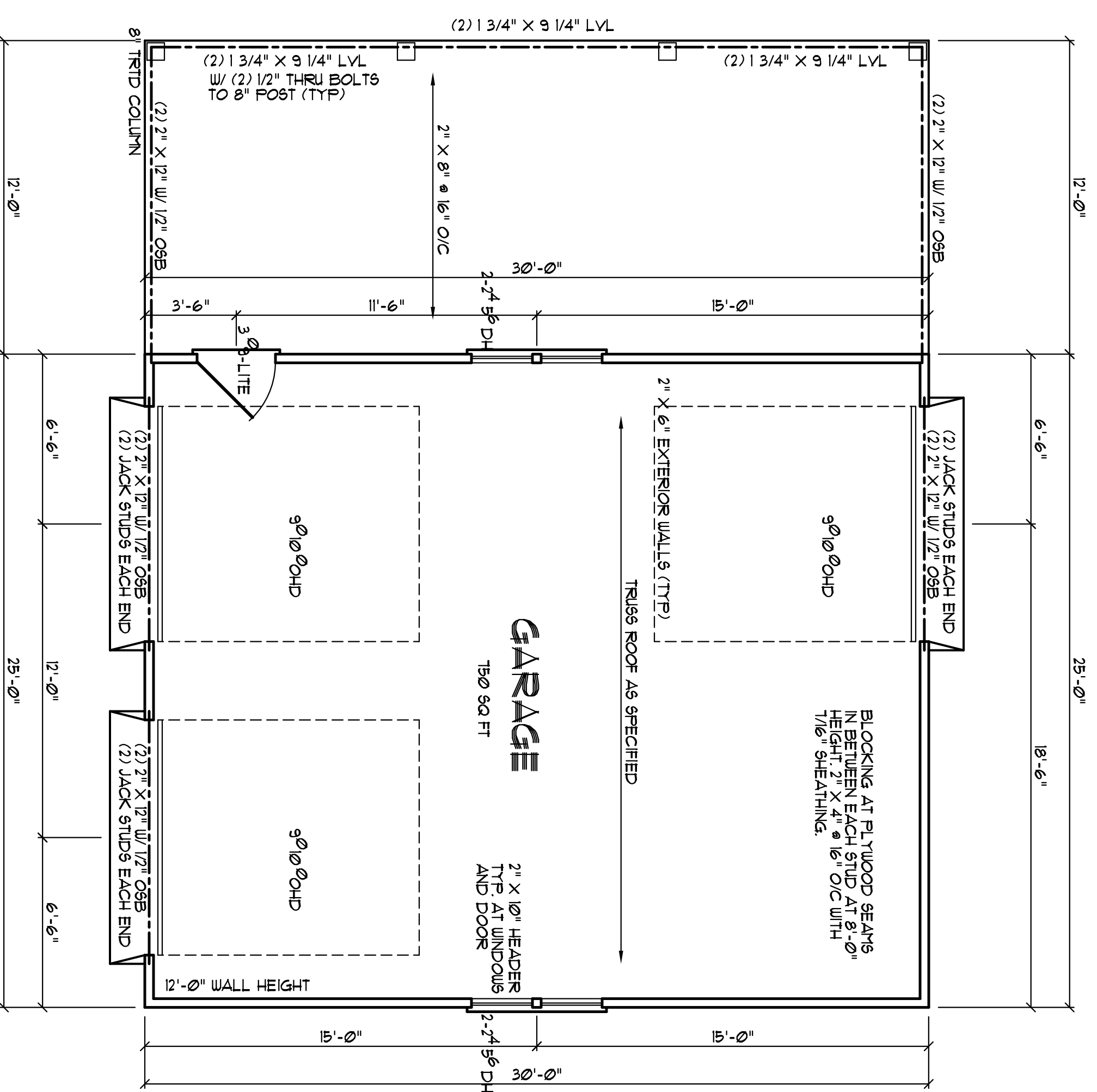

FLOOR PLAN

SCALE: 1/4" = 1'-0"

WALL BRACING FOR THE GARAGE DOORS WILL BE DONE USING PORTAL FRAME GUIDE METHOD IN ACCORDANCE WITH FIGURE 607103.4 OF THE NORTH CAROLINA BUILDING CODE FOR RESIDENCES.

NOTICE TO CONTRACTOR
All construction must comply with current NC Building Codes and is subject to field inspection and verification.

APPROVED
Licensed Building and Planning Permit holder responsible for full compliance with the code

03/25/2021



Harnett COUNTY
NORTH CAROLINA

Dreestley Garage
255 Smithwood Dr
Fuquay Varina, NC

YUNCANNON DESIGNS
CUSTOM HOME PLANS
FUQUAY-VARINA, NC • (919) 551-1116

DRAWN BY: UNV
CHKD BY:
DATE: 03/06/21
REVISIONS:
SHEET
A-1

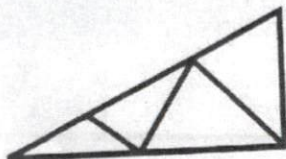

Peak Truss Builders, LLC

PO Box 340, New Hill, NC 27562

Comments and Clarifications

Job #:

Q-2100671

Customer:

Triangle Home Builders

Address:

**7644 Ladora Dr
Willow Springs NC 27592**

Description:

Priestly Bldg

Contact:

Site Address:

Raleigh NC

Notes:

Roof Trusses

Jim Van Der Woude (919) 285.9307

Truss Design Date:

1. All exterior/bearing walls are 2x4 (3-1/2" wide) unless otherwise noted.
2. Overhang - - horizontal truss dimension is 12". Sub-fascia and fascia are beyond.
3. All perimeter dimensions on layout reflect outside to outside of the sheathing. Studs are held in 1/2" to allow sheathing to line up with edge of slab.
4. All trusses and engineered wood require proper bracing and blocking. Some bracing guidance is provided in our Field Installation Package. However, "systematic" or "whole house" bracing is the responsibility of the Engineer of Record.
5. Access by PDS / external stair. Please verify.

I have Reviewed and Approved above Clarifications:

Signed: _____

Date: _____

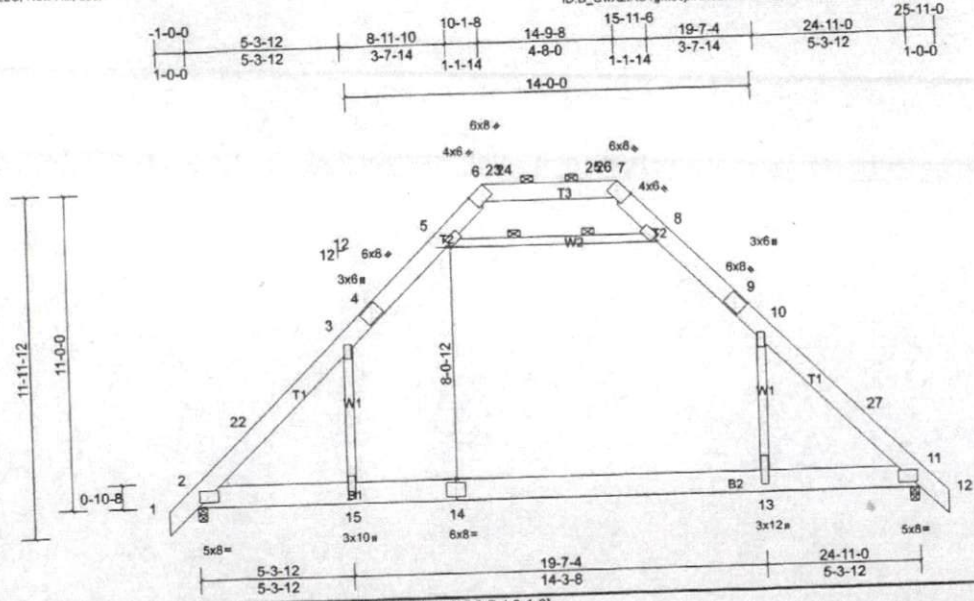

Scale = 1:61.6

Plate Offsets (X, Y): [5:0-1-9,0-2-4], [6:0-2-14,Edge], [7:0-2-14,Edge], [8:0-1-9,0-2-4], [15:0-7-4,0-1-8]

Loading	(psf)	Spacing	2-0-0	CSI	0.91	DEFL	in	(loc)	l/defl	L/d	PLATES	GRIP
TCLL (roof)	20.0	Plate Grip DOL	1.15	TC	0.81	Vert(LL)	-0.38	13-15	>781	240	MT20	244/190
TCDL	10.0	Lumber DOL	1.15	BC	0.53	Vert(CT)	-0.53	13-15	>568	180		
BCLL	0.0*	Rep Stress Incr	YES	WB		Horz(CT)	0.01	11	n/a	n/a		
BCDL	10.0	Code	IRC2015/TPI2014	Matrix-MS		Attic	-0.24	13-15	>724	360	Weight: 241 lb	FT = 20%

LUMBER
 TOP CHORD 2x8 SP No.2 *Except* T1:2x8 SP No.1
 BOT CHORD 2x10 SP No.2 *Except* B2:2x10 SP No.1
 WEBS 2x4 SP No.3

REACTIONS (lb/size) 2=1129/0-3-8, (min. 0-2-4), 11=1129/0-3-8, (min. 0-2-4)
 Max Horiz 2=208 (LC 9)
 Max Uplift 2=76 (LC 11), 11=76 (LC 11)
 Max Grav 2=1451 (LC 21), 11=1451 (LC 22)

BRACING
 TOP CHORD Structural wood sheathing directly applied or 2-2-0 oc purlins, except
 2-0-0 oc purlins (10-0-0 max.); 6-7.
 BOT CHORD Rigid ceiling directly applied or 8-9-4 oc bracing.
 WEBS 2 Rows at 1/3 pts 5-8

MITek recommends that Stabilizers and required cross bracing be installed during truss erection, in accordance with Stabilizer Installation guide.

FORCES (lb) - Max. Comp./Max. Ten. - All forces 250 (lb) or less except when shown.
 TOP CHORD 2-22=-1945/0, 3-22=-1802/18, 3-4=-1096/120, 4-5=-967/153, 5-6=-60/449, 6-23=0/716, 23-24=0/716, 24-25=0/716,
 25-26=0/716, 7-26=0/716, 7-8=-57/450, 8-9=-968/154, 9-10=-1097/120, 10-27=-1808/18, 11-27=-1951/0
 BOT CHORD 2-15=0/1151, 14-15=0/1162, 13-14=0/1162, 11-13=0/1149
 WEBS 3-15=0/1109, 10-13=0/1115, 5-8=-1685/199

- NOTES**
- Unbalanced roof live loads have been considered for this design.
 - Wind: ASCE 7-10; Vult=115mph (3-second gust) Vasd=91mph; TCCL=6.0psf; BCDL=6.0psf; h=30ft; B=20ft; L=25ft; eave=4ft; Cat. II; Exp B; Enclosed; MWFRS (directional)
 2) Wind: ASCE 7-10; Vult=115mph (3-second gust) Vasd=91mph; TCCL=6.0psf; BCDL=6.0psf; h=30ft; B=20ft; L=25ft; eave=4ft; Cat. II; Exp B; Enclosed; MWFRS (directional)
 and C-C Exterior (2) -1-0-0 to 2-0-0, Interior (1) 2-0-0 to 10-1-8, Exterior (2) 10-1-8 to 14-4-7, Interior (1) 14-4-7 to 14-9-8, Exterior (2) 14-9-8 to 19-0-7, Interior (1) 19-0-7 to 25-11-0 zone; cantilever left and right exposed ; end vertical left and right exposed; C-C for members and forces & MWFRS for reactions shown; Lumber DOL=1.60 plate grip DOL=1.60
 - Provide adequate drainage to prevent water ponding.
 - * This truss has been designed for a live load of 20.0psf on the bottom chord in all areas where a rectangle 3-06-00 tall by 2-00-00 wide will fit between the bottom chord and any other members.
 - Ceiling dead load (5.0 psf) on member(s), 3-5, 8-10, 5-8
 - Bottom chord live load (40.0 psf) and additional bottom chord dead load (0.0 psf) applied only to room, 13-15
 - Bottom chord live load (40.0 psf) and additional bottom chord dead load (0.0 psf) applied only to room, 13-15
 - Provide mechanical connection (by others) of truss to bearing plate capable of withstanding 76 lb uplift at joint 2 and 76 lb uplift at joint 11.
 - This truss is designed in accordance with the 2015 International Residential Code sections R502.11.1 and R802.10.2 and referenced standard ANSI/TPI 1.
 - Graphical purlin representation does not depict the size or the orientation of the purlin along the top and/or bottom chord.
 - Attic room checked for L/360 deflection.
- LOAD CASE(S)** Standard

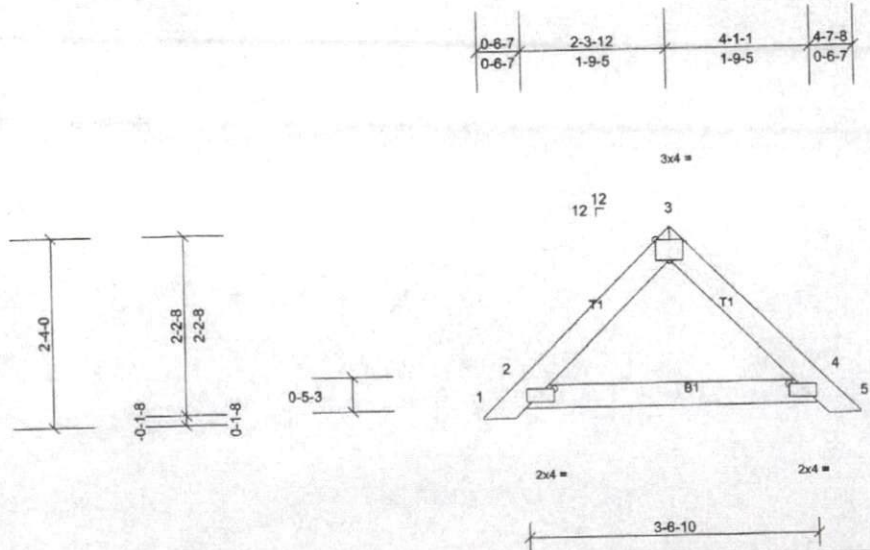

Scale = 1:21.9

Plate Offsets (X, Y): [2:0-2-6,0-1-0], [3:0-2-0,Edge], [4:0-2-6,0-1-0]

Loading	(psf)	Spacing	2-0-0	CSI	DEFL	in (loc)	l/defl	L/d	PLATES	GRIP	
TCLL (roof)	20.0	Plate Grip DCL	1.15	TC	0.04	Vert(LL)	n/a	n/a	999	MT20	244/190
TCDL	10.0	Lumber DOL	1.15	BC	0.05	Vert(CT)	n/a	n/a	999		
BCLL	0.0*	Rep Stress Incr	YES	WB	0.00	Horz(CT)	0.00	2	n/a	n/a	
BCDL	10.0	Code	IRC2015/TPI2014	Matrix-MP							Weight: 15 lb FT = 20%

LUMBER

TOP CHORD 2x4 SP No.1
 BOT CHORD 2x4 SP No.1

REACTIONS All bearings 3-6-10.

(lb) - Max Horiz 2=-39 (LC 9), 6=-39 (LC 9)
 Max Uplift All uplift 100 (lb) or less at joint(s) 2, 4, 6, 9
 Max Grav All reactions 250 (lb) or less at joint(s) 2, 4, 6, 9

FORCES

(lb) - Max. Comp./Max. Ten. - All forces 250 (lb) or less except when shown.

NOTES

- Unbalanced roof live loads have been considered for this design.
- Wind: ASCE 7-10; Vult=115mph (3-second gust) Vasd=91mph; TCCL=6.0psf; BCDL=6.0psf; h=30ft; B=20ft; L=20ft; eave=4ft; Cat. II; Exp B; Enclosed; MWFRS (directional) and C-C Exterior (2) zone; cantilever left and right exposed; end vertical left and right exposed; C-C for members and forces & MWFRS for reactions shown; Lumber DOL=1.60 plate grip DOL=1.60
- Gable requires continuous bottom chord bearing.
- * This truss has been designed for a live load of 20.0psf on the bottom chord in all areas where a rectangle 3-06-00 tall by 2-00-00 wide will fit between the bottom chord and any other members.
- Provide mechanical connection (by others) of truss to bearing plate capable of withstanding 100 lb uplift at joint(s) 2, 4, 2, 4.
- This truss is designed in accordance with the 2015 International Residential Code sections R502.11.1 and R802.10.2 and referenced standard ANSI/TPI 1.
- See Standard Industry Piggyback Truss Connection Detail for Connection to base truss as applicable, or consult qualified building designer.

LOAD CASE(S) Standard

BRACING
 TOP CHORD
 BOT CHORD

Structural wood sheathing directly applied or 4-8-0 oc purlins.
 Rigid ceiling directly applied or 10-0-0 oc bracing.

MiTek recommends that Stabilizers and required cross bracing be installed during truss erection, in accordance with Stabilizer Installation guide.

THIS LAYOUT IS TO BE USED AS A TRUSS PLACEMENT GUIDE ONLY.
 PLEASE REFER TO BUILDING PLANS FOR BUILDING CONSTRUCTION AND DETAILS,
 SUCH AS PLUMBING OR DUCT DROPS.

PROPOSED DESIGN
 NOT FOR
 CONSTRUCTION

Job # Q-2100671
 Priestly Bldg Raleigh NC
 Date Quoted:
 Designer: Nate Donaldson
 Triangle Home Builders 7644 Ladora Dr Willow Springs, NC 27592
 Peak Truss Brothers, LLC PO Box 340, New Hope, NC 27562

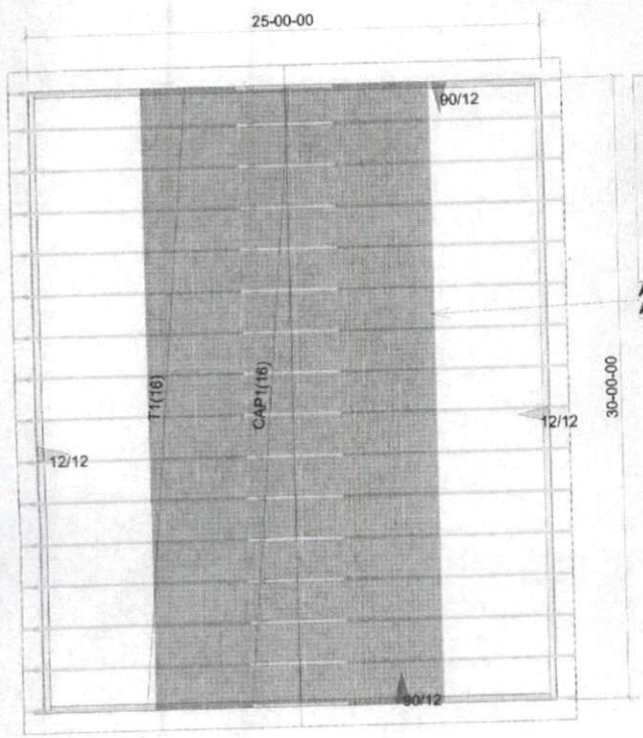

Priestly Bldg Roof Trusses 2' OC, 1' OH

Assumed Ext. Access To
 Attic/Bonus Room

Roof Truss Loading per
 2018 NC Residential Code
 Top Chord Live Load 20# PSF
 Top Chord Dead Load 10# PSF
 Bottom Chord Live Load 0# PSF
 Bottom Chord Dead Load 10# PSF

Trusses are designed for additional
 storage load wherever a 42"x24"
 bay will fit between the walls.

△ This symbol denotes left end of
 truss as shown on truss drawings

⊙ Approximate location of inlet
 drop. Builder please confirm.

Truss connections by others:
 N - Nailed
 L - Lapped

- Notes:
1. Exterior bracing members are required to be:
 - a. Out-of-plane of sheathing
 - b. Out-of-plane of sheathing
 2. Adequate bracing is required for gable ends and mechanical clearance. If less bracing is noted, trusses may be attached as long as O.C. spacing is not exceeded.
 3. Do not cut, drill, or otherwise damage any part of any truss without prior approval from Peak Truss.
 4. Do not approve drawings if any information herein is unclear. Once ordered, trusses will be fabricated as specified.
 5. Please contact Peak Truss Builders with any questions. We are available to help any way we can. We can be reached at 919-643-5555 or sales@peaktruss.com

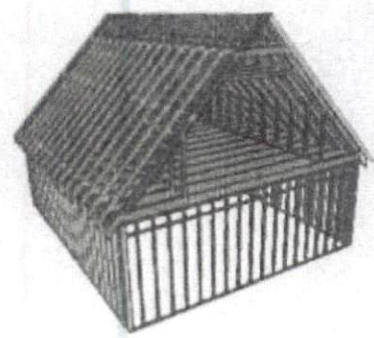
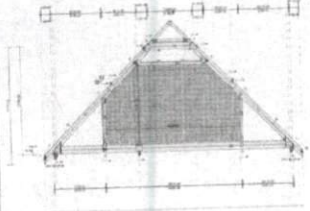

255 Smallwood Dr

Write a description for your map.

Legend

📍 255 Smithwood Dr



Red - Electric power lines, conduit and street light cable	Yellow - Gas, Oil, Steam, petroleum or gaseous material	Orange - Communications, Fiber Optic, CATV, and/or alarm.	Blue - Potable water.	Purple - Reclaimed water, irrigation, and/or stormy lines	Green - Sewers and drains	Pink - Temporary survey marking or unknown structures	White - proposed excavation.
--	---	---	-----------------------	---	---------------------------	---	------------------------------

This is NOT to-scale

888-858-9830 / www.BHUG.com

