



Brian Rose
234 Peach Farm Road
Lillington NC 27546

STRUCTURAL DESIGN

ENCLOSED BUILDING

**MAXIMUM 30'- 0" WIDE X 20'- 0" EAVE HEIGHT-
BOX EAVE FRAME AND BOW FRAME**

**12 April 2019
Revision 0
M&A Project No. 18378S**

Prepared for:

**Carport Central, Inc.
737 South Main Street
Mount Airy, NC 27030**

Prepared by:

Moore and Associates Engineering and Consulting, Inc.

**1009 East Avenue
North Augusta, SC 29841**

**401 S. Main Street, Suite 200
Mount Airy, NC 27030**



**MOORE AND ASSOCIATES
ENGINEERING AND CONSULTING**

		I HAVE RESEARCHED THIS CHAPTER AND THE LOUISIANA STATE UNIFORM CONSTRUCTION CODE AND TO THE BEST OF MY KNOWLEDGE AND BELIEF, THESE DRAWINGS ARE IN COMPLIANCE THEREWITH. I TAKE FULL RESPONSIBILITY FOR THE CONTENTS OF THESE PLANS.	

MOORE AND ASSOCIATES ENGINEERING AND CONSULTING, INC.		DRAWN BY: LT		CARPORT CENTRAL, INC. 737 SOUTH MAIN STREET MOUNT AIRY, NC 27030	
		CHECKED BY: PDH		30'-0" x 20'-0" ENCL. TO STRUCTURE	
PROJECT MGR: VSM		DATE: 4-12-19	SCALE: NTS	JOB NO: 18378S	
CLIENT: CC		SHT. 1	DWG. NO: SK-3	REV. 0	

THIS DOCUMENT IS THE PROPERTY OF MOORE AND ASSOCIATES ENGINEERING AND CONSULTING. THE UNAUTHORIZED REPRODUCTION, COPYING, OR OTHERWISE USE OF THIS DOCUMENT IS STRICTLY PROHIBITED AND ANY INFRACTION THEREUPON MAY BE SUBJECT TO LEGAL ACTION.

	<p>Professional Certification. I hereby certify that these documents were prepared or approved by me, and that I am a duly licensed professional engineer under the laws of the State of Maryland, License No. 49744, Expiration Date 8/8/20 4/12/19</p>		

**MOORE AND ASSOCIATES
ENGINEERING AND CONSULTING, INC.**

DRAWN BY: LT

CHECKED BY: PDH

PROJECT MGR: VSM

CLIENT: CC

CARPOT CENTRAL, INC.
737 SOUTH MAIN STREET
MOUNT AIRY, NC 27030
30'-0" x 20'-0" ENCLOSED STRUCTURE

DATE: 4-12-19

SHT. 1A

SCALE: NTS

DWG. NO: SK-3

JOB NO: 162763

REV: 0

THIS DOCUMENT IS THE PROPERTY OF MOORE AND ASSOCIATES ENGINEERING AND CONSULTING. THE UNAUTHORIZED REPRODUCTION, COPYING, OR OTHERWISE USE OF THIS DOCUMENT IS STRICTLY PROHIBITED AND ANY OFFENSE THEREUPON MAY BE SUBJECT TO LEGAL ACTION.

INSTALLATION NOTES AND SPECIFICATIONS

1. DESIGN IS FOR MAXIMUM 30'-0" WIDE x 20'-0" EAVE HEIGHT ENCLOSED STRUCTURES.
2. DESIGN WAS DONE IN ACCORDANCE WITH THE 2018 NORTH CAROLINA BUILDING CODE, 2017 FLORIDA BUILDING CODE (FBC) 6TH EDITION, 2018 INTERNATIONAL BUILDING CODE (IBC), 2006 IBC, 2009 IBC, 2012 IBC, 2015 IBC, AND 2018 IBC.
3. DESIGN LOADS ARE AS FOLLOWS:
 - A) DEAD LOAD = 1.5 PSF
 - B) LIVE LOAD = 12 PSF
 - C) GROUND SNOW LOAD = 33 PSF AT 5'-0" O.C. SPACING
 = 42 PSF AT 4'-0" O.C. SPACING.
 30 PSF (WITH U-CHANNEL PEAK BRACE) W ≤ 26'-0"
 (UNBALANCED SNOW LOADS DUE TO DRIFTING HAVE NOT BEEN EVALUATED.)
4. ULTIMATE WIND SPEED 105 TO 143 MPH (NOMINAL WIND SPEED 82 TO 110 MPH)
 MAXIMUM RAFTER/COLUMN AND END COLUMN SPACING = 5.0 FEET
5. ULTIMATE WIND SPEED 144 TO 155 MPH (NOMINAL WIND SPEED 111 TO 120 MPH)
 MAXIMUM RAFTER/COLUMN AND END COLUMN SPACING = 4.0 FEET
6. END WALL COLUMNS (POSTS) ARE SIMILAR TO SIDE WALL POSTS IN SIZE AND SPACING UNLESS NOTED OTHERWISE.
7. LDW HAZARD RISK CATEGORY I.
8. WIND EXPOSURE CATEGORY B.
9. SPECIFICATIONS APPLICABLE TO 29 GAUGE METAL PANELS FASTENED DIRECTLY TO 2 1/4" x 2 1/4" - 14 GAUGE TUBE STEEL (TS) FRAMING MEMBERS (UNLESS NOTED OTHERWISE).
10. AVERAGE FASTENER SPACING ON-CENTERS ALONG RAFTERS OR HAT CHANNELS, AND COLUMNS (INTERIOR OR END) = 8 INCHES.
11. FASTENERS CONSIST OF #12-14x3/4" (UNLESS OTHERWISE NOTED) SELF-DRILLING FASTENER (SDF), USE CONTROL SEAL WASHER WITH EXTERIOR FASTENERS. SPECIFICATIONS APPLICABLE ONLY FOR MEAN ROOF HEIGHT OF 20 FEET OR LESS AND ROOF SLOPES OF 14° (3:12) PITCH OR LESS. SPACING REQUIREMENTS FOR OTHER ROOF HEIGHTS AND/OR SLOPES MAY VARY.
12. ANCHORS SHALL BE INSTALLED THROUGH BASE RAIL WITHIN 6" OF EACH COLUMN
13. STANDARD GROUND ANCHORS (SOIL NAILS) CONSIST OF #4 REBAR W/ WELDED NUT x 36" LONG. SOIL NAILS MAY BE USED FOR MAXIMUM WIND V = 145 MPH AND IN SUITABLE SOIL CONDITIONS. OPTIONAL ANCHORAGE MAY BE USED IN SUITABLE SOILS AND MUST BE USED FOR WIND V > 145 MPH AND/OR IN UNSUITABLE SOILS AS NOTED.
14. WIND FORCES GOVERN OVER SEISMIC FORCES. SEISMIC PARAMETERS ANALYZED ARE:
 SOIL SITE CLASS = D
 RISK CATEGORY I/II/III
 R= 3.25 I_e= 1.0
 S_{DS}= 2.039 g V= C_sW
 S_{D1}= 1.258 g
15. DOOR AND WINDOW PRESSURES APPLICABLE TO THE STATE OF FLORIDA.

** CarportCentral Authorized Manufacturer Of Customer Use Only**

Brian Rose
 234 Peach Farm Road
 Lillington NC 27546

MOORE AND ASSOCIATES
 ENGINEERING AND CONSULTING, INC.

DRAWN BY: LT	CARPORT CENTRAL, INC. 737 SOUTH MAIN STREET MOUNT AIRY, NC 27030		
CHECKED BY: PDH	30'-0"x20'-0" ENCLOSED STRUCTURE		
PROJECT MGR: WSM	DATE: 4-12-19	SCALE: NTS	JOB NO: 1937RS
CLIENT: CC	SHT: 3	DWG. NO: SK-3	REV: 0

THIS DOCUMENT IS THE PROPERTY OF MOORE AND ASSOCIATES ENGINEERING AND CONSULTING, INC. UNAUTHORIZED REPRODUCTION, COPYING, OR OTHERWISE USE OF THIS DOCUMENT IS STRICTLY PROHIBITED AND ANY VIOLATION THEREOF MAY BE SUBJECT TO LEGAL ACTION.

BOX EAVE FRAME RAFTER STRUCTURE

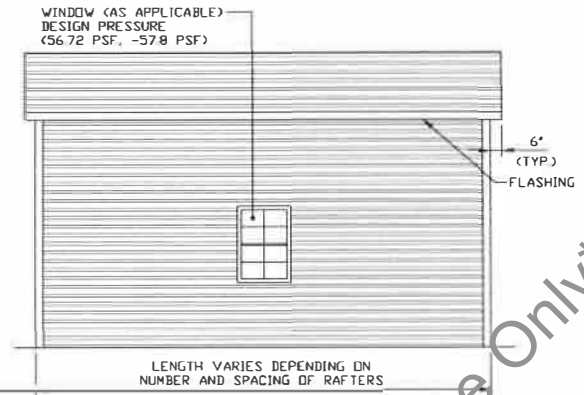
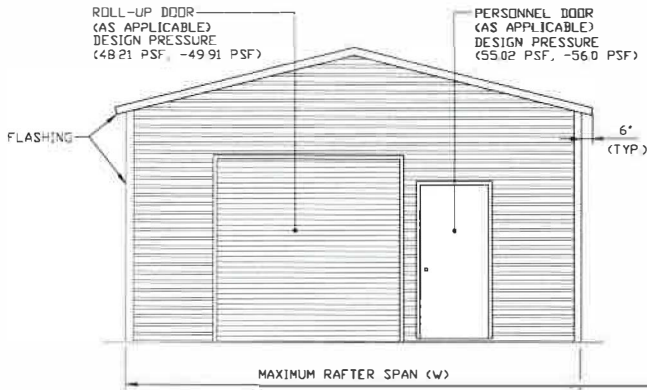

TYPICAL END ELEVATION-HORIZONTAL ROOF **TYPICAL SIDE ELEVATION-HORIZONTAL ROOF**
 SCALE: NTS SCALE: NTS

BOW FRAME RAFTER STRUCTURE

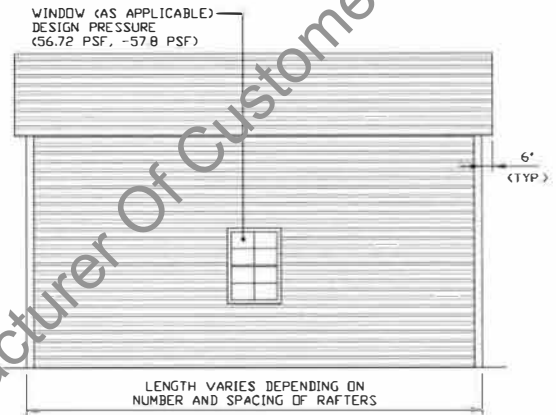
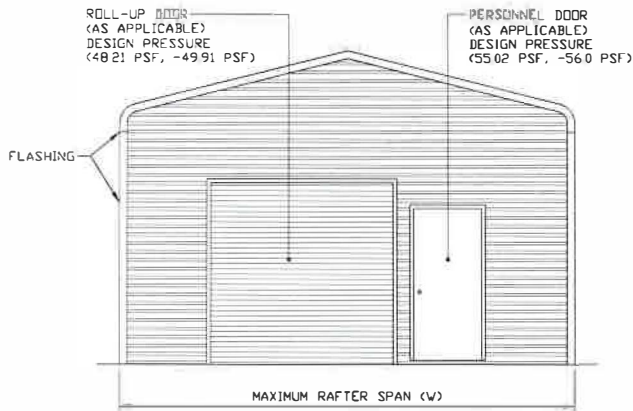

TYPICAL END ELEVATION
 SCALE: NTS

TYPICAL END ELEVATION
 SCALE: NTS

*** CarportCentral Authorized Manufacturer Of Customer Use Only***

Brian Rose
 234 Peach Farm Road
 Lillington NC 27546

CARPORNT CENTRAL, INC.
 737 SOUTH MAIN STREET
 MOUNT AIRY, NC 27030
 30'-0" x 20'-0" ENCLOSED STRUCTURE

MOORE AND ASSOCIATES
 ENGINEERING AND CONSULTING, INC.

DRAWN BY: LT

CHECKED BY: PDH

PROJECT MGR: WSH

CLIENT: CC

DATE: 4-12-19

SHT. 3A

SCALE: NTS

DWG. NO SK-3

JOB NO: 18378S

REV: 0

THIS DOCUMENT IS THE PROPERTY OF MOORE AND ASSOCIATES ENGINEERING AND CONSULTING. THE UNAUTHORIZED REPRODUCTION, COPYING, OR OTHERWISE USE OF THIS DOCUMENT IS STRICTLY PROHIBITED AND ANY VIOLATION THEREOF MAY BE SUBJECT TO LEGAL ACTION.

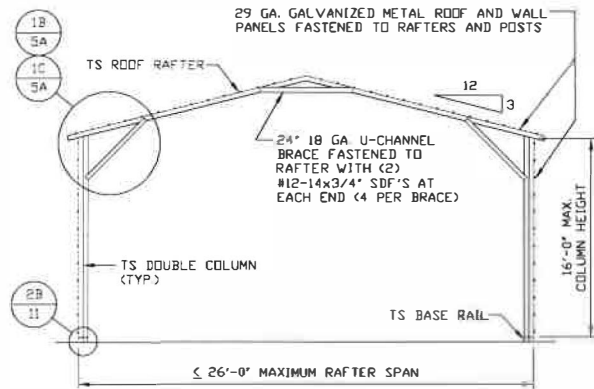

TYPICAL RAFTER/COLUMN END FRAME SECTION

SCALE: NTS

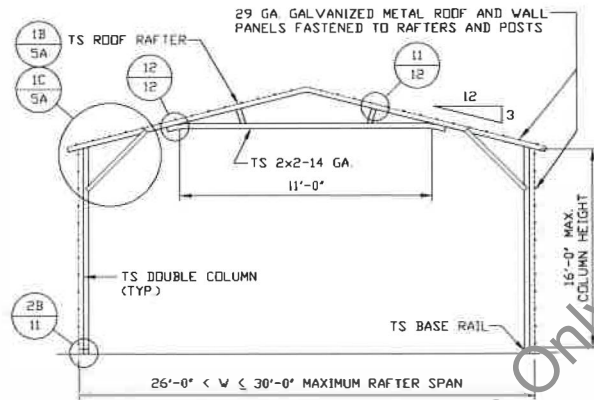

TYPICAL RAFTER/COLUMN END FRAME SECTION

SCALE: NTS

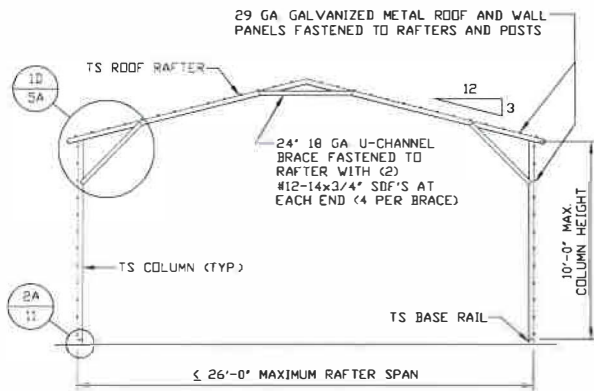

TYPICAL RAFTER/COLUMN END FRAME SECTION

SCALE: NTS

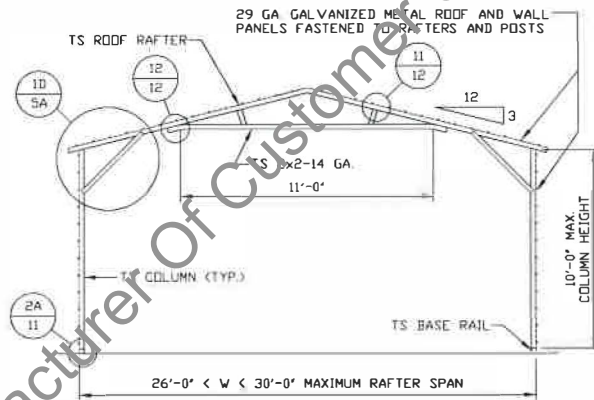

TYPICAL RAFTER/COLUMN END FRAME SECTION

SCALE: NTS

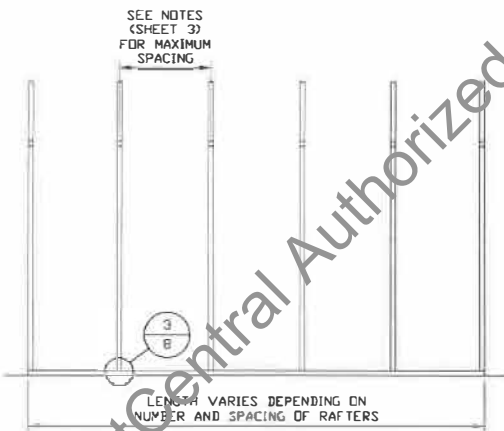

TYPICAL RAFTER/COLUMN SIDE FRAMING SECTION

SCALE: NTS

Brian Rose
234 Peach Farm Road
Lillington NC 27546

CARPOR CENTRAL, INC.
737 SOUTH MAIN STREET
MOUNT AIRY, NC 27030
30'-0" x 20'-0" ENCLOSED STRUCTURE

MOORE AND ASSOCIATES
ENGINEERING AND CONSULTING, INC.

DRAWN BY: LT

CHECKED BY: PDH

PROJECT MGR: VSM

CLIENT: CC

DATE: 4-12-19

SHT. 4A

SCALE: NTS

DWG. NO: SK-3

JOB NO: 18378S

REV: 0

THIS DOCUMENT IS THE PROPERTY OF MOORE AND ASSOCIATES ENGINEERING AND CONSULTING, INC. UNAUTHORIZED REPRODUCTION, COPYING, OR OTHERWISE USE OF THIS DOCUMENT IS STRICTLY PROHIBITED AND ANY VIOLATION THEREOF MAY BE SUBJECT TO LEGAL ACTION.

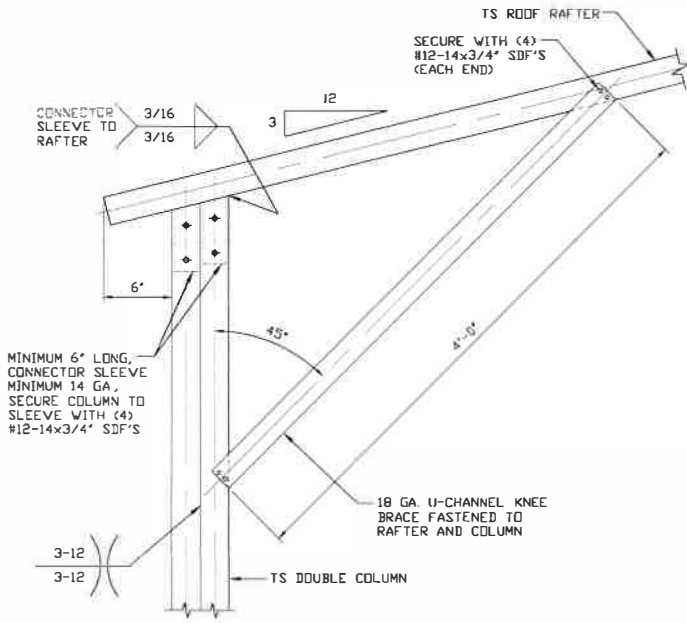

1B
BOX EAVE RAFTER COLUMN CONNECTION DETAIL FOR HEIGHTS 12'-0" < TO ≤ 16'-0"
 SCALE: NTS

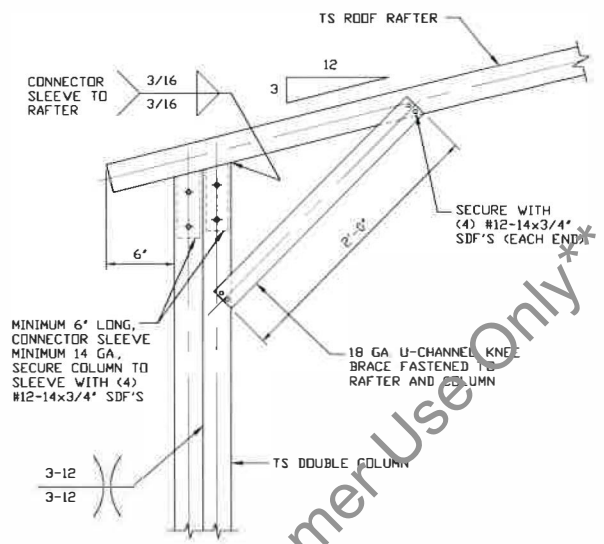

1C
BOX EAVE RAFTER COLUMN CONNECTION DETAIL FOR HEIGHTS 10'-0" < TO ≤ 12'-0"
 SCALE: NTS

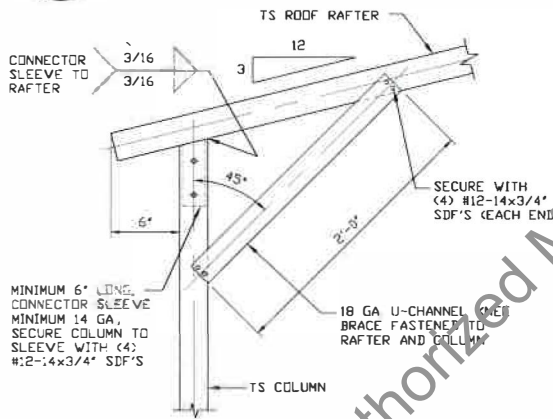

1D
BOX EAVE RAFTER COLUMN CONNECTION DETAIL FOR HEIGHTS < 10'-0"
 SCALE: NTS

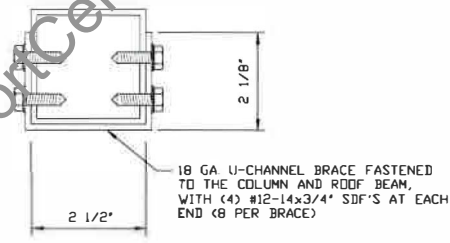

BRACE SECTION
 SCALE: NTS

Brian Rose
 234 Peach Farm Road
 Lillington NC 27546

MOORE AND ASSOCIATES ENGINEERING AND CONSULTING, INC.

DRAWN BY: LT	CARPORT CENTRAL, INC. 737 SOUTH MAIN STREET MOUNT AIRY, NC 27030		
CHECKED BY: PDH	30'-0" x 20'-0" ENCLOSED STRUCTURE		
PROJECT MGR: VSM	DATE: 4-12-19	SCALE: NTS	JOB NO: 18378S
CLIENT: CC	SHT: 5A	DWG. NO: SK-3	REV: 0

THIS DOCUMENT IS THE PROPERTY OF MOORE AND ASSOCIATES ENGINEERING AND CONSULTING. THE UNAUTHORIZED REPRODUCTION, COPYING, OR OTHERWISE USE OF THIS DOCUMENT IS STRICTLY PROHIBITED AND ANY INFRINGEMENT THEREUPON MAY BE SUBJECT TO LEGAL ACTION.

BASE RAIL ANCHORAGE OPTIONS

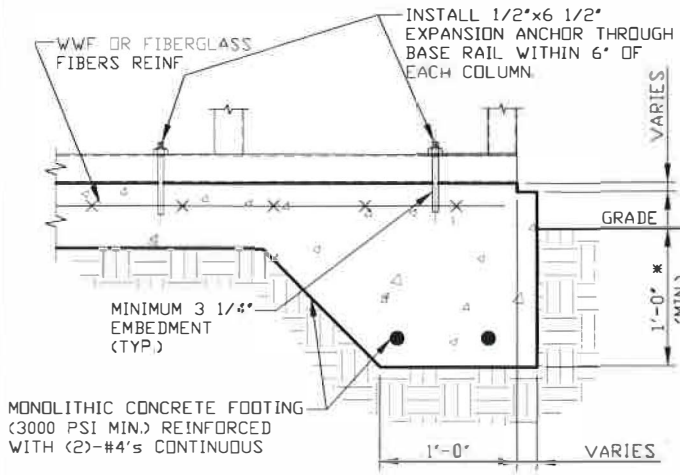

3A CONCRETE MONOLITHIC SLAB BASE RAIL ANCHORAGE
 SCALE: NTS
 MINIMUM ANCHOR EDGE DISTANCE IS 4".
 * COORDINATE WITH LOCAL CODES/ORD.

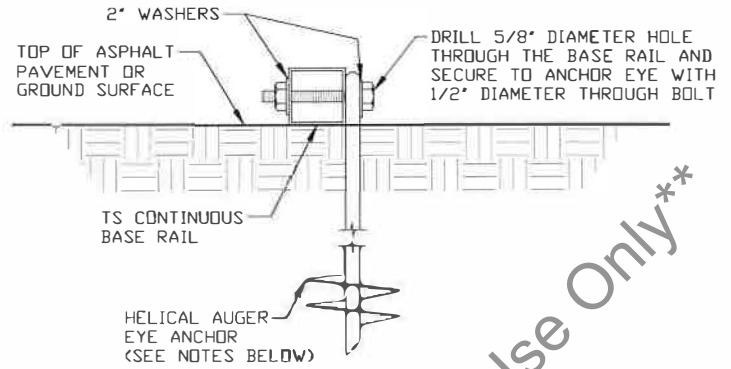

3B HELICAL AUGER ANCHORAGE
 SCALE: NTS (CAN BE USED FOR ASPHALT)

GENERAL NOTES

NOTE: CONCRETE MONOLITHIC SLAB DESIGN BASED ON MINIMUM SOIL BEARING CAPACITY OF 1,500 PSF.

CONCRETE:

CONCRETE SHALL HAVE A MINIMUM SPECIFIED COMPRESSIVE STRENGTH OF 3,000 PSI AT 28 DAYS.

COVER OVER REINFORCING STEEL:

FOR FOUNDATIONS, MINIMUM CONCRETE COVER OVER REINFORCING BARS SHALL BE PER ACI-318:
 3" IN FOUNDATIONS WHERE THE CONCRETE IS CAST AGAINST AND PERMANENTLY IN CONTACT WITH THE EARTH OR EXPOSED TO THE EARTH OR WEATHER, AND 1 1/2" ELSEWHERE.

REINFORCING STEEL:

THE TURNDOWN REINFORCING STEEL SHALL BE ASTM A615 GRADE 60. THE SLAB REINFORCEMENT SHALL BE WELDED WIRE FABRIC MEETING ASTM A185 OR FIBERGLASS FIBER REINFORCEMENT.

REINFORCEMENT MAY BE BENT IN THE SHOP OR THE FIELD PROVIDED:

- 1 REINFORCEMENT IS BENT COLD.
- 2 THE DIAMETER OF THE BEND, MEASURED ON THE INSIDE OF THE BAR, IS NOT LESS THAN SIX-BAR DIAMETER.
- 3 REINFORCEMENT PARTIALLY EMBEDDED IN CONCRETE SHALL NOT BE FIELD BENT.

HELICAL AUGER ANCHOR NOTES:

- 1 FOR VERY DENSE AND/OR CEMENTED SANDS, COARSE GRAVEL AND COBBLES, CALICHE, PRELOADED SILTS AND CLAYS, USE MINIMUM (2) 4" HELICES WITH MINIMUM 30" EMBEDMENT OR SINGLE 6" HELIX WITH MINIMUM 50" EMBEDMENT.
- 2 FOR CORAL USE MINIMUM (2) 4" HELICES WITH MINIMUM 30" EMBEDMENT OR SINGLE 6" HELIX WITH MINIMUM 50" EMBEDMENT.
- 3 FOR MEDIUM DENSE COARSE SANDS, SANDY GRAVELS, VERY STIFF SILTS, AND CLAYS USE MINIMUM (2) 4" HELICES WITH MINIMUM 30" EMBEDMENT OR SINGLE 6" HELIX WITH MINIMUM 50" EMBEDMENT.
- 4 FOR LOOSE TO MEDIUM DENSE SANDS, FIRM TO STIFF CLAYS AND SILTS ALLUVIAL FILL, USE MINIMUM (2) 6" HELICES WITH MINIMUM 50" EMBEDMENT.
- 5* FOR VERY LOOSE TO MEDIUM DENSE SANDS, FIRM TO STIFFER CLAYS AND SILTS, ALLUVIAL FILL, USE MINIMUM (2) 8" HELICES WITH MINIMUM 60" EMBEDMENT.

Brian Rose
 234 Peach Farm Road
 Lillington NC 27546

MOORE AND ASSOCIATES
ENGINEERING AND CONSULTING, INC.

DRAWN BY: LT

CHECKED BY: PDH

PROJECT MGR: WSH

CLIENT: CC

CARPORT CENTRAL, INC.
 737 SOUTH MAIN STREET
 MOUNT AIRY, NC 27030
 30'-0"X20'-0" ENCLOSED STRUCTURE

DATE: 4-12-19

SHT. 8

SCALE: NTS

DWG. NO: SK-3

JOB NO: 18378S

REV: 0

THIS DOCUMENT IS THE PROPERTY OF MOORE AND ASSOCIATES ENGINEERING AND CONSULTING. THE UNAUTHORIZED REPRODUCTION, COPYING, OR OTHERWISE USE OF THIS DOCUMENT IS STRICTLY PROHIBITED AND ANY INFRACTION THEREUPON MAY BE SUBJECT TO LEGAL ACTION.

BASE RAIL ANCHORAGE OPTIONS

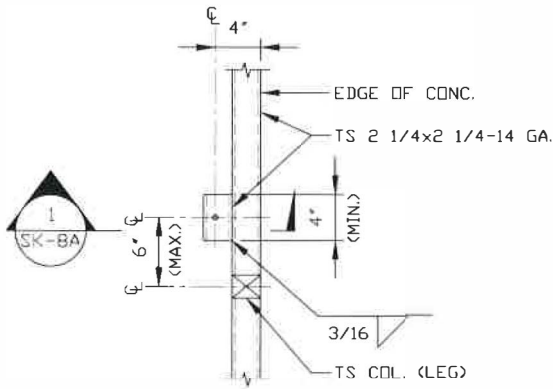

TYPICAL ANCHOR DETAIL WHEN BASE RAIL IS NEAR EDGE OF CONCRETE

SCALE: NTS

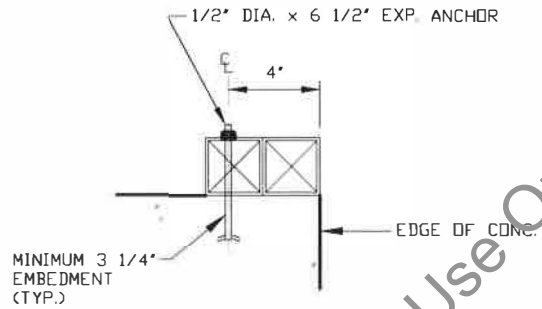

SECTION

SCALE: NTS

**** CarportCentral Authorized Manufacturer Of Customer Use Only****

Brian Rose
 234 Peach Farm Road
 Lillington NC 27546

CARPORT CENTRAL, INC.
 737 SOUTH MAIN STREET
 MOUNT AIRY, NC 27030
 30'-0" x 20'-0" ENCLOSED STRUCTURE

MOORE AND ASSOCIATES
 ENGINEERING AND CONSULTING, INC.

DRAWN BY: LT

CHECKED BY: PDH

PROJECT MGR: WSM

CLIENT: CC

DATE: 4-12-19

SHT. 8A

SCALE: NTS

DWG. NO: SK-3

JOB NO: 18378S

REV: 0

THIS DOCUMENT IS THE PROPERTY OF MOORE AND ASSOCIATES ENGINEERING AND CONSULTING. THE UNAUTHORIZED REPRODUCTION, COPYING, OR OTHERWISE USE OF THIS DOCUMENT IS STRICTLY PROHIBITED AND ANY INFRINGEMENT THEREUPON MAY BE SUBJECT TO LEGAL ACTION.

BOX EAVE RAFTER END WALL AND SIDE WALL OPENINGS

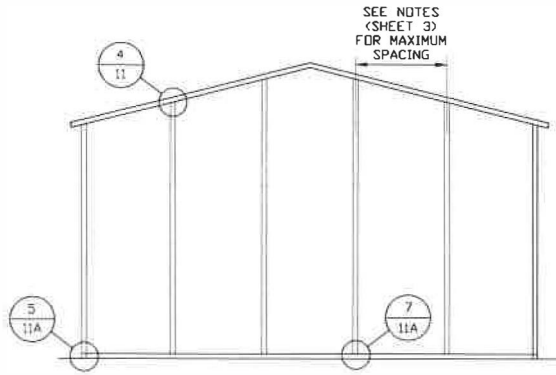

TYPICAL BOX EAVE RAFTER END WALL FRAMING SECTION

SCALE: NTS

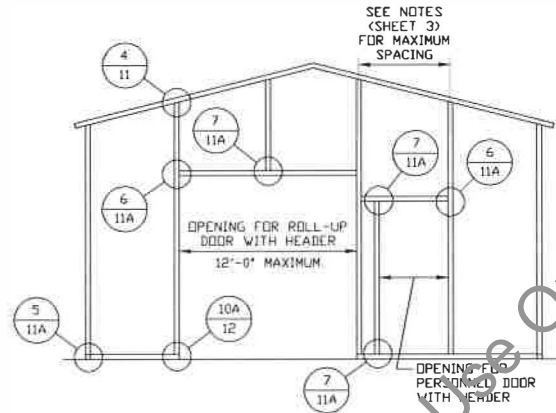

TYPICAL BOX EAVE RAFTER END WALL OPENINGS FRAMING SECTION

SCALE: NTS

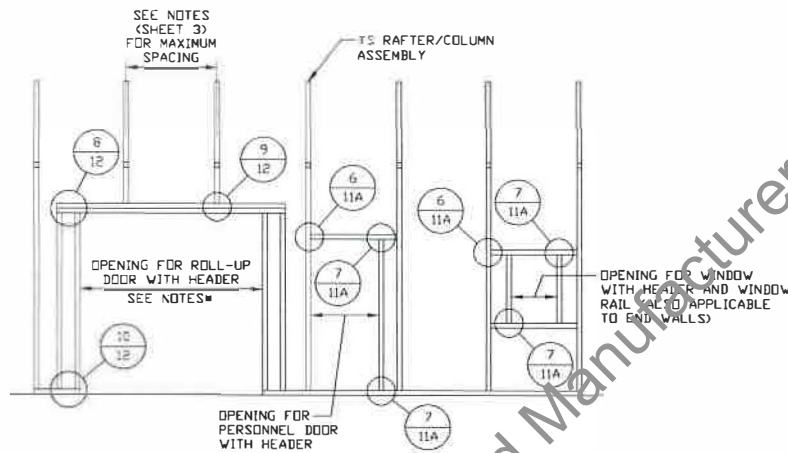

TYPICAL BOX EAVE RAFTER SIDE WALL OPENINGS FRAMING SECTION

SCALE: NTS

NOTES:

- * 10'-0" MAX. FOR 5'-0" O.C. RAFTER/COLUMN SPACING.
- * 9'-0" MAX. FOR 4'-0" O.C. RAFTER/COLUMN SPACING.

** CarportCentral Authorized Manufacturer Of Customer Use Only**

Brian Rose
 234 Peach Farm Road
 Lillington NC 27546

CARPOT CENTRAL, INC.
 737 SOUTH MAIN STREET
 MOUNT AIRY, NC 27030
 30'-0"x20'-0" ENCLOSED STRUCTURE

MOORE AND ASSOCIATES
 ENGINEERING AND CONSULTING, INC.

DRAWN BY: LT

CHECKED BY: PDH

PROJECT MGR: WSM

CLIENT: CC

DATE: 4-12-19

SHT. 9

SCALE: NTS

DWG. NO: SK-3

JOB NO: 18378S

REV.: 0

THIS DOCUMENT IS THE PROPERTY OF MOORE AND ASSOCIATES ENGINEERING AND CONSULTING. THE UNAUTHORIZED REPRODUCTION, COPYING, OR OTHERWISE USE OF THIS DOCUMENT IS STRICTLY PROHIBITED AND ANY INFINGEMENT THEREUPON MAY BE SUBJECT TO LEGAL ACTION.

CONNECTION DETAILS

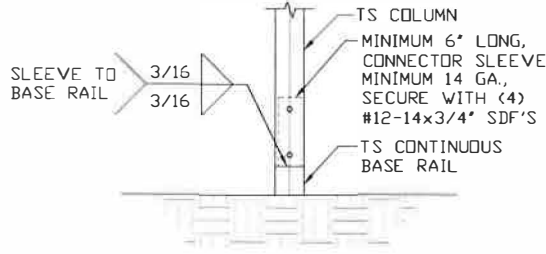

2A RAFTER COLUMN/BASE RAIL CONNECTION DETAIL
SCALE: NTS

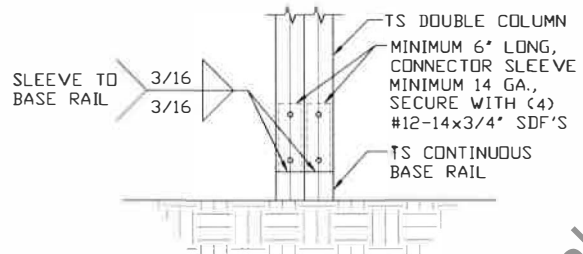

2B RAFTER COLUMN/BASE RAIL CONNECTION DETAIL
SCALE: NTS

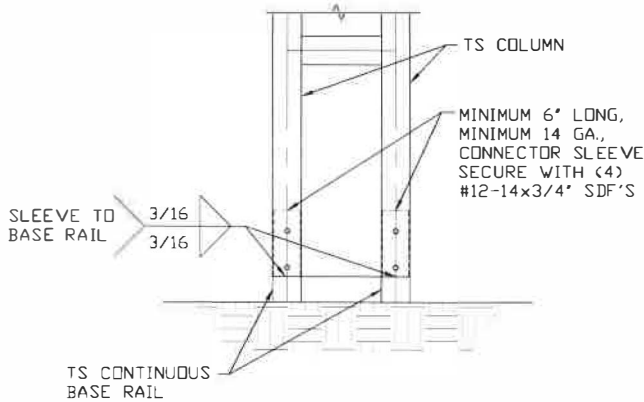

2C RAFTER COLUMN/BASE RAIL CONNECTION DETAIL
SCALE: NTS

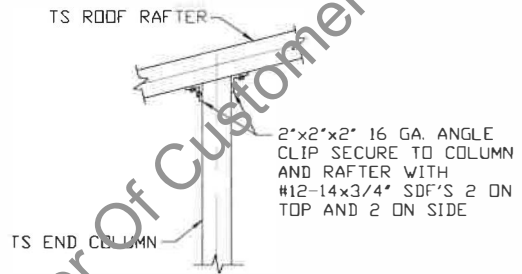

4 END COLUMN/RAFTER CONNECTION DETAIL
SCALE: NTS

**** CarportCentral Authorized Manufacturer Of Customer Use Only****

Brian Rose
234 Peach Farm Road
Lillington NC 27546

CARPOT CENTRAL, INC.
737 SOUTH MAIN STREET
MOUNT AIRY, NC 27030
30'-0" x 20'-0" ENCLOSED STRUCTURE

MOORE AND ASSOCIATES
ENGINEERING AND CONSULTING, INC.

DRAWN BY: LT

CHECKED BY: PDH

PROJECT MGR: WSM

CLIENT: CC

DATE: 4-12-19

SHT. 11

SCALE: NTS

DWG. NO: SK-3

JOB NO: 18378S

REV: 0

THIS DOCUMENT IS THE PROPERTY OF MOORE AND ASSOCIATES ENGINEERING AND CONSULTING. THE UNAUTHORIZED REPRODUCTION, COPYING, OR OTHERWISE USE OF THIS DOCUMENT IS STRICTLY PROHIBITED AND ANY INFRINGEMENT THEREUPON MAY BE SUBJECT TO LEGAL ACTION.

CONNECTION DETAILS

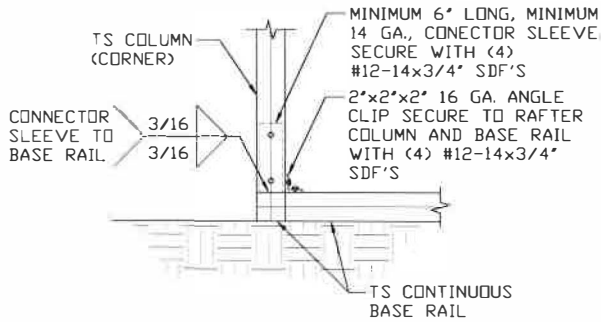

5 END COLUMN/BASE RAIL CONNECTION DETAIL
SCALE: NTS

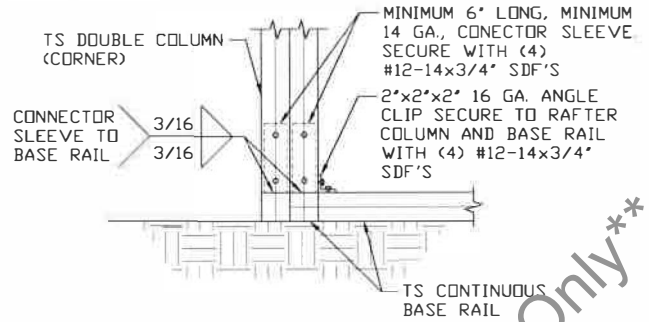

5A END COLUMN/BASE RAIL CONNECTION DETAIL
SCALE: NTS

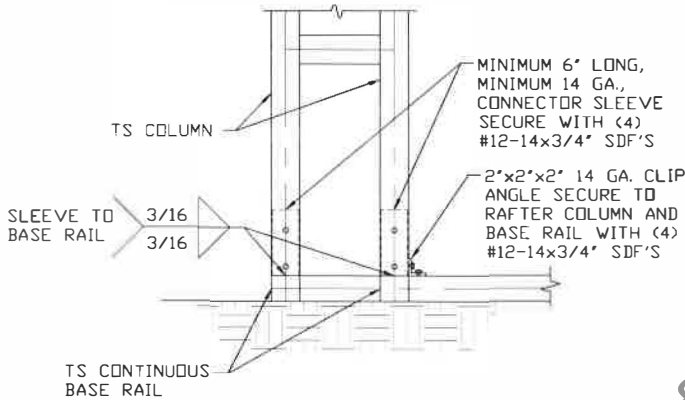

5B END COLUMN/BASE RAIL CONNECTION DETAIL
SCALE: NTS

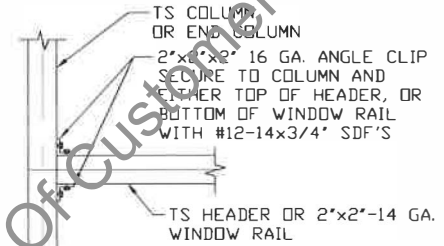

6 COLUMN OR WINDOW RAIL TO POST CONNECTION DETAIL
SCALE: NTS

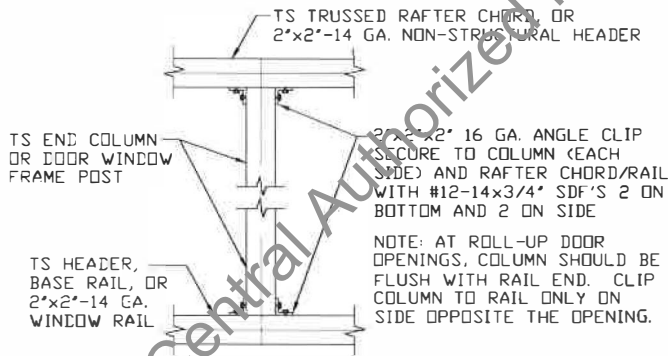

7 COLUMN TO HEADER, BASE RAIL, OR WINDOW RAIL CONNECTION DETAIL
SCALE: NTS

Brian Rose
234 Peach Farm Road
Lillington NC 27546

CARPOT CENTRAL, INC.
737 SOUTH MAIN STREET
MOUNT AIRY, NC 27030
30'-0" x 20'-0" ENCLOSED STRUCTURE

MOORE AND ASSOCIATES
ENGINEERING AND CONSULTING, INC.

DRAWN BY: LT

CHECKED BY: PDH

PROJECT MGR: WSM

CLIENT: CC

DATE: 4-12-19

SHT. 11A

SCALE: NTS

DWG. NO SK-3

JOB NO: 18378S

REV: 0

THIS DOCUMENT IS THE PROPERTY OF MOORE AND ASSOCIATES ENGINEERING AND CONSULTING, INC. UNAUTHORIZED REPRODUCTION, COPYING, OR OTHERWISE USE OF THIS DOCUMENT IS STRICTLY PROHIBITED AND ANY VIOLATION THEREOF MAY BE SUBJECT TO LEGAL ACTION.

CONNECTION DETAILS

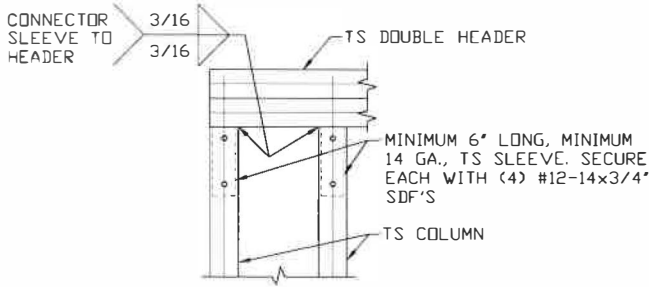

8 **DOUBLE HEADER/COLUMN CONNECTION DETAIL**
SCALE: NTS

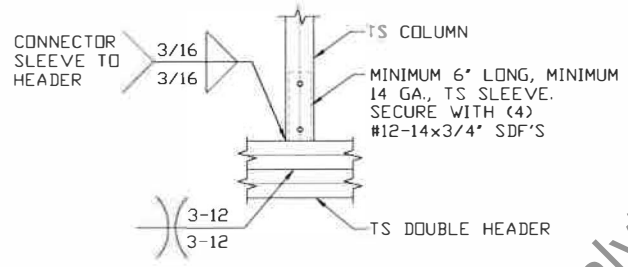

9 **COLUMN/DOUBLE HEADER CONNECTION DETAIL**
SCALE: NTS

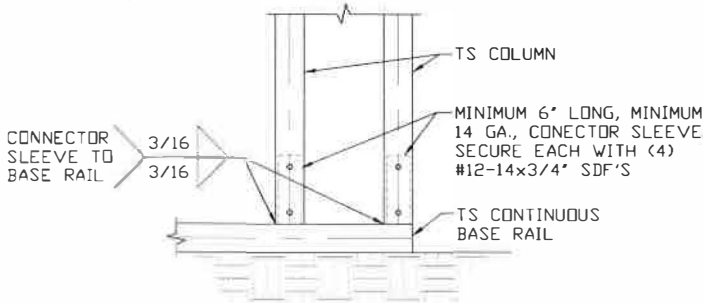

10 **COLUMN/BASE RAIL CONNECTION DETAIL**
SCALE: NTS

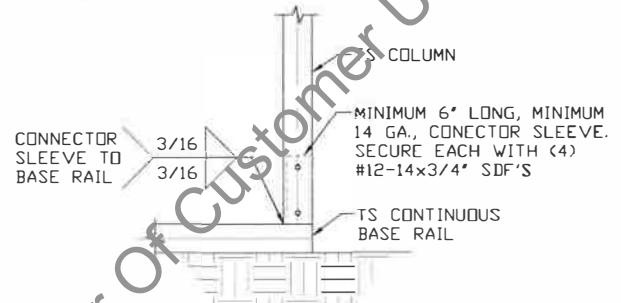

10A **COLUMN/BASE RAIL CONNECTION DETAIL**
SCALE: NTS

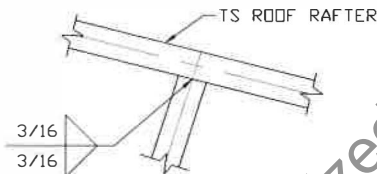

11 **RAFTER TO CHORD CONNECTION DETAIL**
SCALE: NTS

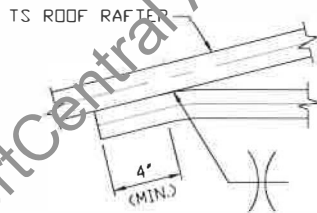

12 **COLLAR TIE CONNECTION DETAIL**
SCALE: NTS

**** CarportCentral Authorized Manufacturer Of Customer Use Only****

Brian Rose
234 Peach Farm Road
Lillington NC 27546

CARPORT CENTRAL, INC.
737 SOUTH MAIN STREET
MOUNT AIRY, NC 27030
30'-0" x 20'-0" ENCLOSED STRUCTURE

**MOORE AND ASSOCIATES
ENGINEERING AND CONSULTING, INC.**

DRAWN BY: LT

CHECKED BY: PDH

PROJECT MGR: WSM

CLIENT: CC

DATE: 4-12-19

SHT. 12

SCALE: NTS

DWG. NO: SK-3

JOB NO: 18378S

REV: 0

THIS DOCUMENT IS THE PROPERTY OF MOORE AND ASSOCIATES ENGINEERING AND CONSULTING. THE UNAUTHORIZED REPRODUCTION, COPYING, OR OTHERWISE USE OF THIS DOCUMENT IS STRICTLY PROHIBITED AND ANY OFFENSE THEREFOR MAY BE SUBJECT TO LEGAL ACTION.

OPTIONAL HEADER

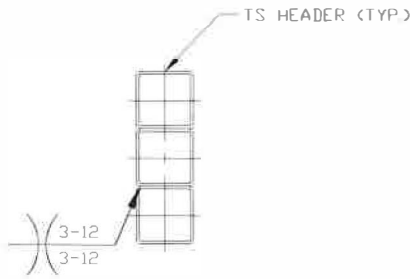

HEADER DETAIL FOR
 OPENINGS 10'-0" < LENGTH ≤ 15'-0"
 WITH 5'-0" D.C. RAFTER/COLUMN SPACING
 OR HEADER DETAIL FOR
 OPENINGS 9'-0" < LENGTH ≤ 13'-0"
 WITH 4'-0" D.C. RAFTER/COLUMN SPACING
 SCALE: NTS

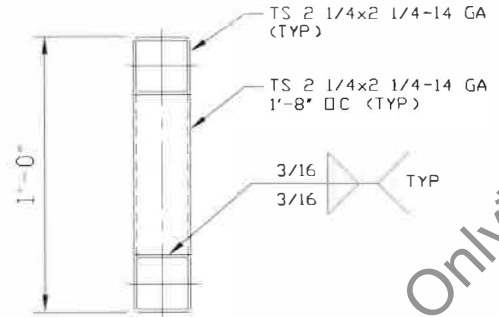

HEADER DETAIL FOR
 OPENINGS 15'-0" < LENGTH ≤ 20'-0"
 WITH 5'-0" D.C. RAFTER/COLUMN SPACING
 OR HEADER DETAIL FOR
 OPENINGS 13'-0" < LENGTH ≤ 20'-0"
 WITH 4'-0" D.C. RAFTER/COLUMN SPACING
 SCALE: NTS

**** CarportCentral Authorized Manufacturer Of Customer Use Only****

Brian Rose
 234 Peach Farm Road
 Lillington NC 27546

CARPORT CENTRAL, INC.
 737 SOUTH MAIN STREET
 MOUNT AIRY, NC 27030
 30'-0"x20'-0" ENCLOSED STRUCTURE

MOORE AND ASSOCIATES
ENGINEERING AND CONSULTING, INC.

DRAWN BY: LT

CHECKED BY: PDH

PROJECT MGR: WSH

CLIENT: CC

DATE: 4-12-19

SHT. 18

SCALE: NTS

DWG. NO: SK-3

JOB NO: 18378S

REV: 0

THIS DOCUMENT IS THE PROPERTY OF MOORE AND ASSOCIATES ENGINEERING AND CONSULTING. THE UNAUTHORIZED REPRODUCTION, COPYING, OR OTHERWISE USE OF THIS DOCUMENT IS STRICTLY PROHIBITED AND ANY INFRINGEMENT THEREUPON MAY BE SUBJECT TO LEGAL ACTION.