

# STANDARD CARPORT DETAILS 12 ft to 24 ft SPAN

CAROLINA CARPORTS, INC.  
P.O. BOX 1263  
DOBSON, NC 27017  
TOLL FREE 1-800-670-4262  
LOCAL 336-367-6400  
FAX 336-367-6410



This document is the property of Carolina Carports, Inc. Use of these plans without the permission of Carolina Carports is prohibited.

TABLE 1 BOW/RAFTER FRAME, END POST, GROUND ANCHOR AND PANEL FASTENER SPACING SPECIFICATIONS						
WIND EXPOSURE CATEGORY	ULTIMATE WIND SPEED (MPH)	NOMINAL WIND SPEED (MPH)	MAXIMUM GROUND SNOW LOAD (PSF)	MAXIMUM POST/RAFTER SPACING (FEET)	AVERAGE FASTENER SPACING ON-CENTERS ALONG RAFTERS OR PURLINS, AND POSTS OR GIRTS (INCHES)	
					METAL PANELS	SPACING
B OR C	105 TO 140	85 TO 112	35	5.0	29 Gauge	8
			65	4.0	29 Gauge	

- NOTES: 1. Specifications applicable to 29 gauge metal panels fastened directly to 12 or 14 gauge steel tube bow frames.  
2. Fasteners consist of #12 x 1/2" self-drilling screws with control seal washers.  
3. Specifications applicable only for mean roof height of 24 feet or less and roof slopes of 7 to 27 degrees (1.5:12 to 8:12 pitch). Spacing requirements for other roof heights and/or slopes may vary.

TABLE 1 (HIGH WIND REGION) BOW/RAFTER FRAME, END POST, GROUND ANCHOR AND PANEL FASTENER SPACING SPECIFICATIONS						
WIND EXPOSURE CATEGORY	ULTIMATE WIND SPEED (MPH)	NOMINAL WIND SPEED (MPH)	MAXIMUM GROUND SNOW LOAD (PSF)	MAXIMUM POST/RAFTER SPACING (FEET)	AVERAGE FASTENER SPACING ON-CENTERS ALONG RAFTERS OR PURLINS, AND POSTS OR GIRTS (INCHES)	
					METAL PANELS	SPACING
B OR C	141 TO 150	113 TO 121	30	5.0	29 Gauge	8
			20	4.0	26 Gauge	
B, C OR D	151 TO 170	122 TO 136	20	4.0	26 Gauge	6

- NOTES: 1. Specifications applicable to 29 gauge and 26 gauge metal panels fastened directly to 12 or 14 gauge steel tube bow frames.  
2. Fasteners consist of #12 x 1/2" self-drilling screws with control seal washers.  
3. Specifications applicable only for mean roof height of 24 feet or less and roof slopes of 7 to 27 degrees (1.5:12 to 8:12 pitch). Spacing requirements for other roof heights and/or slopes may vary.

**GENERAL NOTES:**  
THESE PLANS PERTAIN ONLY TO THE STRUCTURE, INCLUDING MAIN WIND FORCE RESISTING SYSTEM (MWFRS), COMPONENTS AND GLAZING, AND BASE RAIL ANCHORAGE. OTHER DESIGN ISSUES, INCLUDING, BUT NOT LIMITED TO, PLUMBING, ELECTRICAL, HEATING/COOLING, PROPERTY SET-BACKS, OR OTHER LOCAL ZONING REQUIREMENTS ARE THE RESPONSIBILITY OF OTHERS.  
THESE STRUCTURES ARE DESIGNED AS UTILITY/STORAGE BUILDINGS CAPABLE OF SUPPORTING THE DEAD LOAD OF THE STRUCTURE AND APPLICABLE LIVE AND WIND LOADS. IMPROVEMENTS NOT SPECIFICALLY ADDRESSED HEREIN, WHICH EXERT ADDITIONAL LOADS ON THE STRUCTURE SHALL BE AT THE OWNER'S RISK. CAROLINA CARPORTS SHALL NOT BE RESPONSIBLE FOR STRUCTURAL DAMAGE OR FAILURE DUE TO THE APPLICATION OF ADDITIONAL LOADS.  
ALL STEEL TUBING SHALL BE 55 KSI STEEL OR BETTER. ALL METAL PANELS SHALL BE 80 KSI STEEL OR BETTER.  
FASTEN METAL ROOF AND WALL PANELS TO FRAMING WITH #12 x 1/2" SELF DRILLING FASTENERS WITH CONTROL SEAL WASHERS AT AN AVERAGE SPACING OF 8" FOR 29 GAUGE PANELS AND 6" FOR 26 GAUGE PANELS.  
ALL FIELD CONNECTIONS SHALL BE #12 x 1/2" SELF DRILLING FASTENERS (SDF) UNLESS NOTED OTHERWISE.  
ALL WELDED CONNECTIONS SHALL BE SHOP WELDED UNLESS NOTED OTHERWISE.  
GROUND ANCHOR REQUIREMENTS: INSTALL HELICAL ANCHORS WITHIN 6" OF EACH CORNER POST AND AT A MAXIMUM SPACING OF 25' ALONG THE BASE RAIL. INSTALL GROUND RODS (#4 THREADED REBAR) BETWEEN THE HELICAL ANCHORS AT A MAXIMUM SPACING OF 5' AND A MINIMUM SPACING OF 6' ALONG THE BASE RAIL. HELICAL ANCHORS AND GROUND RODS ARE NOT REQUIRED FOR CONCRETE FOOTING AND/OR CONCRETE SLAB CONSTRUCTION.  
CONCRETE EXPANSION ANCHORS SHALL BE ITW RAMMED/HEAD-LOAD TRUSS WEDGE ANCHOR, WEJ-IT ANCHOR-TITE MODEL AT1252, OR SLEEVE ANCHOR MODEL HSA 1260, OR APPROVED EQUAL.  
POST/RAFTER BRACING: BRACE ON EVERY POST/RAFTER CONNECTION, EXCEPT FOR END WALLS AND HEADERS.  
GALVANIZATION: METAL ACCESSORIES FOR USE IN EXTERIOR WALL CONSTRUCTION AND NOT DIRECTLY EXPOSED TO THE WEATHER SHALL BE GALVANIZED IN ACCORDANCE WITH ASTM A 153, CLASS B-2. METAL PLATE CONNECTORS, SCREWS, BOLTS AND NAILS EXPOSED DIRECTLY TO THE WEATHER SHALL BE STAINLESS STEEL OR HOT DIPPED GALVANIZED.

NOTE: USE 2" x 2" x 1/4" GALV. STEEL TUBE FOR ALL FRAME AND BASE RAIL MEMBERS UNLESS OTHERWISE SHOWN.



**CONCRETE FOUNDATION DESIGN RECOMMENDATIONS:**  
CONCRETE SLAB AND FOUNDATION ARE BY OTHERS. COORDINATE CONCRETE STRENGTH AND FOUNDATION DEPTH REQUIREMENTS WITH THE LOCAL BUILDING CODE OFFICIALS. THE OWNER IS RESPONSIBLE FOR PROVIDING A SUITABLE FOUNDATION FOR THE PROPOSED STRUCTURE.  
CONCRETE SHALL HAVE A MINIMUM SPECIFIED COMPRESSIVE STRENGTH OF 3000 PSI AT 28 DAYS OR AS REQUIRED BY LOCAL BUILDING CODE. THE USE OF HIGHER STRENGTH CONCRETE IS ACCEPTABLE.  
COVER OVER REINFORCING STEEL: MINIMUM CONCRETE COVER REINFORCING BARS SHALL BE 3 INCHES WHERE CONCRETE IS CAST AGAINST AND PERMANENTLY IN CONTACT WITH THE EARTH OR EXPOSED TO THE EARTH OR WEATHER AND 1 1/2" ELSEWHERE.  
REINFORCING STEEL: THE REINFORCING STEEL SHALL BE MINIMUM GRADE 40.

## METAL CARPORT INSTALLATION PLANS AND DETAILS AND FRAMING AND FASTENER SPECIFICATIONS

CAROLINA CARPORTS, INC.  
187 Cardinal Ridge Trail  
DOBSON, NORTH CAROLINA 27017

THE OWNER IS RESPONSIBLE FOR OBTAINING A BUILDING PERMIT, IF NEEDED, AND FOR COMPLYING WITH ALL LOCAL BUILDING CODE REQUIREMENTS.

THIS IS TO CERTIFY THAT THE CALCULATIONS AND SPECIFICATIONS HEREIN HAVE BEEN PREPARED BY THE UNDERSIGNED PROFESSIONAL ENGINEER, AND ARE IN ACCORDANCE WITH THE REQUIREMENTS OF THE 2009, 2012, 2015 & 2018 INTERNATIONAL BUILDING CODES AND THE 2018 NORTH CAROLINA BUILDING CODE.

BUILDING CODE INFORMATION	
OCCUPANCY CATEGORY	I
USE GROUP	U
CONSTRUCTION TYPE	5B

IMPORTANCE FACTORS	
WIND I <sub>a</sub>	1.0
SNOW I <sub>s</sub>	0.8
EARTHQUAKE I <sub>e</sub>	1.0

DESIGN LOADS	
MIN. DEAD LOAD	5 PSF
MIN. FLOOR LIVE LOAD	100 PSF
MIN. ROOF LIVE LOAD	30 PSF
MIN. GROUND SNOW LOAD	
MIN. GROUND SHOW LOAD	
MIN. ULTIMATE WIND SPEED	SEE TABLE 1
MIN. ULTIMATE WIND SPEED EXPOSURE CATEGORY	SEE TABLE 1
SEISMIC RESPONSE COEFFICIENT	0.500

These plans have been provided for the requirements of obtaining a building permit for:  
**Ed Champin**  
2777 Byrds Mill Rd  
Erwin, NC 28339  
Zip: 28339

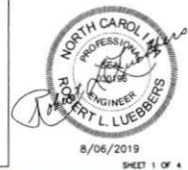

Use of these plans by anyone else or for any other purpose is prohibited.

8/06/2019  
SHEET 1 OF 4

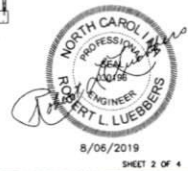
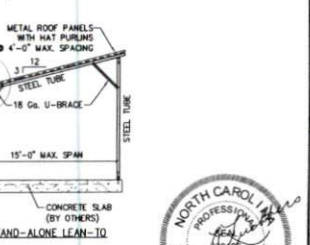
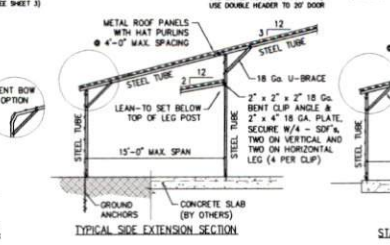
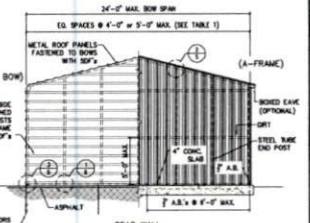
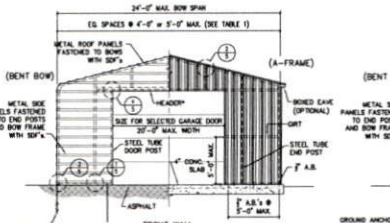
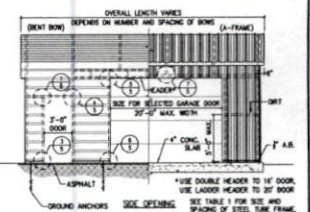
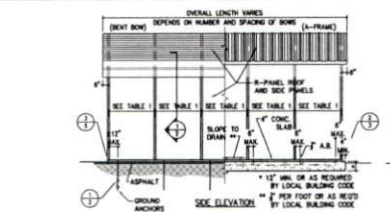
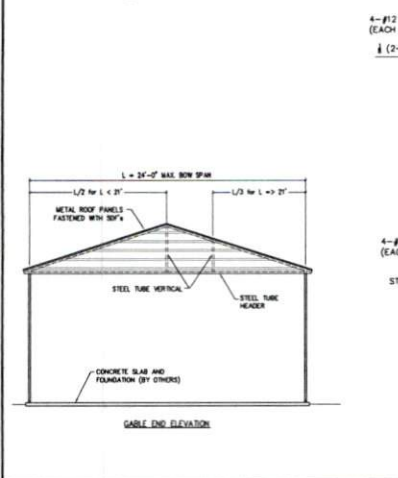
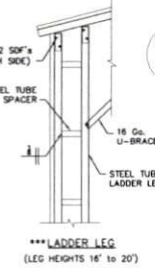
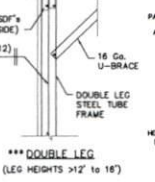
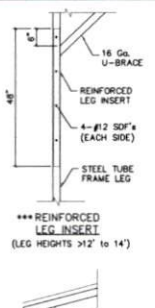
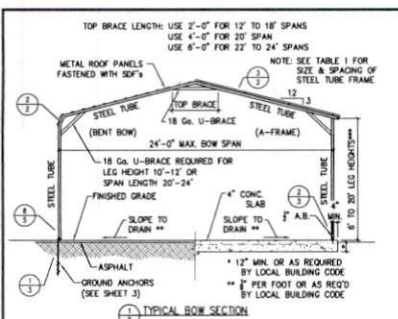

Use of these plans by anyone else or for any other purpose is prohibited.

8/06/2019  
SHEET 2 OF 4

DRILL  $\frac{1}{2}$ " HOLE THROUGH THE BASE RAIL AND SECURE TO ANCHOR EYE WITH  $\frac{3}{8}$ " THROUGH BOLT.

STEEL TUBE BASE RAIL

2" WASHERS

FINISHED GRADE

GROUND ANCHOR  $\frac{3}{4}$ " x 30" WITH 2 - 4" HELIX AND  $\frac{3}{4}$ " EYE BOLT OR OTHER APPROVED HELICAL ANCHOR (THE MAXIMUM ALLOWABLE LOAD IS 3,150 LBS PER ANCHOR)

CONCRETE SLAB (BY OTHERS)

COMPACTED SUBGRADE

INSTALL  $\frac{3}{8}$ " MECHANICAL ANCHOR THROUGH BASE RAIL WITHIN 6" OF EACH BOW

STEEL TUBE BASE RAIL

FINISHED GRADE

EMBEDMENT

4" THICK BASE OF COARSE AGGREGATE OR CRUSHED STONE (OPTIONAL)

MONOLITHIC CONCRETE FOOTING REINFORCED WITH 2 - #4'S CONTINUOUS (BY OTHERS)

CONCRETE BASE RAIL ANCHORAGE (SINGLE LEG)

INSTALL  $\frac{3}{8}$ " MECHANICAL ANCHOR THROUGH BASE RAIL WITHIN 6" OF EACH BOW (MAY ALTERNATE & STAGGER)

STEEL TUBE BASE RAIL

FINISHED GRADE

EMBEDMENT

4" THICK BASE OF COARSE AGGREGATE OR CRUSHED STONE (OPTIONAL)

MONOLITHIC CONCRETE FOOTING (BY OTHERS), REINFORCED WITH 2 - #4'S CONTINUOUS

CONCRETE BASE RAIL ANCHORAGE (DOUBLE LEG)

**SOIL CLASSIFICATIONS\***

SOIL CLASS SOIL DESCRIPTION

2 Very dense &/or cemented sands, coarse gravel and cobbles, calciche, protofossils, and clay.

3 Medium dense coarse sands, sandy gravels, very stiff silts, and clay.

4 Loose to medium dense sands, firm to stiff clay and silts (alluvial) and VERY loose to medium dense sands, firm to stiff clay and silts, alluvial fill.

THE HELICAL ANCHOR SHALL BE APPROVED FOR USE IN SOIL CLASSIFICATIONS 2, 3, AND 4.

\* Taken from HUD "Standard for Installation of Mobile Homes"

**SOIL BASE RAIL ANCHOR DETAIL**

NOTE: IF THE DISTANCE BETWEEN HELICAL ANCHORS EXCEEDS 25', PROVIDE AN ADDITIONAL HELICAL ANCHOR MIDWAY BETWEEN.

NOTE: SEE TABLE 1 FOR SIZE & SPACING OF STEEL TUBE FRAME

NOTE: SEE TABLE 1 FOR SIZE & SPACING OF STEEL TUBE FRAME

HELVICAL GROUND ANCHORS (BY OTHERS)

ANCHOR BOLTS

CONCRETE SHALL HAVE A MINIMUM SPECIFIED COMPRESSIVE STRENGTH (FC) OF 3000 PSI AT 28 DAYS. THE USE OF HIGHER STRENGTH CONCRETE IS ACCEPTABLE.

MINIMUM CONCRETE COVER OVER REINFORCING BARS SHALL BE 3 INCHES FOR FOUNDATION WHERE CONCRETE IS CAST AGAINST AND PERMANENTLY IN CONTACT WITH THE EARTH OR EXPOSED TO THE WEATHER AND 1 1/2 INCHES ELSEWHERE. REINFORCING BARS EMBEDDED IN GROUDED CELLS SHALL HAVE A MINIMUM CLEAR DISTANCE OF 1/2 INCH FOR THE GROUT AND 1/2 INCH FOR COARSE GROUT BETWEEN REINFORCING BARS AND ANY FACE OF A CELL. REINFORCING BARS USED IN MASONRY WALLS SHALL HAVE A MASONRY COVER (INCLUDING GROUT) OF NOT LESS THAN 2 INCHES FOR MASONRY UNITS WITH FACE EXPOSED TO EARTH OR WEATHER AND 1 1/2 INCHES ELSEWHERE.

THE REINFORCING STEEL SHALL BE MINIMUM GRADE 40

REINFORCEMENT MAY BE BENT IN THE SHOP OR THE FIELD PROVIDED: ALL REINFORCEMENT IS COLD BENT; THE DIAMETER OF THE BEND MEASURED ON THE INSIDE OF THE BAR IS NOT LESS THAN SIX BAR DIAMETERS; AND REINFORCEMENT PARTIALLY EMBEDDED IN CONCRETE SHALL NOT BE FIELD BENT EXCEPT WHERE BENDING IS NECESSARY TO ALIGN DOWEL BARS WITH A VERTICAL CELL BARS PARTIALLY EMBEDDED IN CONCRETE MAY BE BENT AT A SLOPE OF NOT MORE THAN 1 INCH OF HORIZONTAL DISPLACEMENT TO 8 INCHES OF VERTICAL BAR LENGTH.

**ALTERNATE BASE RAIL ANCHORAGE**

18 GAGE BENT RAIL CLIP

2 - SDP's AT EACH RAIL CLIP

CONCRETE SLAB (BY OTHERS)

COMPACTED SUBGRADE

FINISHED GRADE

EMBEDMENT

4" THICK BASE OF COARSE AGGREGATE OR CRUSHED STONE (OPTIONAL)

MONOLITHIC CONCRETE FOOTING (BY OTHERS), REINFORCED WITH 2 - #4'S CONTINUOUS

**ALTERNATE BASE RAIL CLIP**

18 GAGE CLIP ANGLE

WELDED TO BASE RAIL

$\frac{3}{8}$ " ANCHOR BOLT

FINISHED GRADE

EMBEDMENT

4" THICK BASE OF COARSE AGGREGATE OR CRUSHED STONE (OPTIONAL)

MONOLITHIC CONCRETE FOOTING (BY OTHERS), REINFORCED WITH 2 - #4'S CONTINUOUS

**CONCRETE BASE RAIL ANCHORAGE (DOUBLE LEG)**

8/06/2019

SHEET 3 OF 4

**NORTH CAROLINA PROFESSIONAL ENGINEER ROBERT L. LUEBBERS**

STEEL BOW BOW FRAME

STEEL TUBE BOW FRAME

6" LONG 14 Gg. NIPPLE, SECURE RAFTER TO NIPPLE W/4 - SDP's, TWO ON EACH SIDE

DOUBLE STEEL TUBE DOORWAY HEADER

NIPPLE TO HEADER

**BOW / HEADER DETAIL**

6" LONG 14 Gg. NIPPLE, SECURE LEG TO NIPPLE W/4 - SDP's, TWO ON EACH SIDE (4 PER SPLICE)

STEEL TUBE BOW LEG

STEEL TUBE BASE RAIL

NIPPLE TO BASE RAIL WELD

**BOW/BASE RAIL CONNECTION DETAIL**

SEE TABLE 1 FOR SIZE AND SPACING OF STEEL TUBE FRAME.

**BOW FRAME/HEADER DETAIL**

STEEL TUBE BOW FRAME

6" LONG 14 Gg. NIPPLE, SECURE POST TO NIPPLE WITH 2 - SDP's, TWO ON EACH SIDE

DOUBLE STEEL TUBE DOORWAY HEADER

NIPPLE TO HEADER

**BOW / HEADER DETAIL**

STEEL TUBE BOW FRAME

2" x 2" x 2" 18 Gg. CLIP ANGLES, SECURE W/4 - SDP's, TWO ON VERTICAL AND TWO ON HORIZONTAL LEG (4 PER CLIP)

STEEL TUBE BOW FRAME (END)

STEEL TUBE DOOR POST

STEEL TUBE BASE RAIL (END)

BASE RAIL WELD

**END BOW/BASE RAIL CONNECTION**

STEEL TUBE BOW FRAME

2" x 2" x 2" 18 Gg. CLIP ANGLES, SECURE W/4 - SDP's, TWO ON VERTICAL AND TWO ON HORIZONTAL LEG (4 PER CLIP)

STEEL TUBE BOW FRAME

STEEL TUBE DOOR POST

NIPPLE TO HEADER WELD

**POST/BASE RAIL DETAIL**

STEEL TUBE BOW FRAME

2" x 2" x 2" 18 Gg. CLIP ANGLES, SECURE W/4 - SDP's, TWO ON VERTICAL AND TWO ON HORIZONTAL LEG (4 PER CLIP)

STEEL TUBE DOOR POST

STEEL TUBE GRT

EXTEND HEADER TO FULL HEIGHT LEG

**END POST/BASE RAIL CONNECTION DETAIL**

STEEL TUBE BOW FRAME

2" x 2" x 2" 18 Gg. BENT CLIP ANGLES, SECURE W/4 - SDP's, TWO ON VERTICAL AND TWO ON HORIZONTAL LEG (4 PER CLIP)

STEEL TUBE END POST

STEEL TUBE BOW FRAME

STEEL TUBE GRT

EXTEND HEADER TO FULL HEIGHT LEG

**END POST TO BOW FRAME CONNECTION**

6" LONG 14 Gg. NIPPLE, SECURE RAFTER TO NIPPLE W/4 - SDP's, TWO ON EACH SIDE (4 PER SPLICE)

STEEL TUBE BOW RAFTER EXTENSION

STEEL TUBE BOW POST

**BOW/POST DETAIL**

STEEL TUBE BOW RAFTER

U-CHANNEL BRACE

B = 2'-0" FOR HEIGHT = 6' TO 8'

B = 3'-0" FOR HEIGHT = 8' TO 10'

B = 4'-0" FOR HEIGHT > 10'

6" LONG 14 Gg. NIPPLE, SECURE POST TO NIPPLE W/4 - SDP's, TWO ON EACH SIDE (4 PER SPLICE)

STEEL TUBE BOW POST

**BOW/POST DETAIL**

SECTION THROUGH DOOR POST

SECTION THROUGH ROLL-UP DOOR POST

STEEL TUBE DOOR POST

METAL SIDE PANELS

EXTERIOR

STEEL TUBE DOOR POST

CURTAIN

INTERIOR

METAL ROOF PANEL

1 1/2" 16 GAGE HAT CHANNEL FASTENED TO EACH BOW WITH 2 - SDP's AND SPACED NOT MORE THAN 4'-0" O.C.

STEEL TUBE BOW RAFTER

**VERTICAL PANEL ATTACHMENT**

MAXIMUM FURIN SPACING

GROUND FURIN SNOW PANEL LOAD

PSF	IT
30	4.00
35	4.00
40	4.00
45	4.00
50	4.00
55	4.00
60	4.00
65	4.00
70	3.50
75	3.50
80	3.00

PLAN

MINIMUM DISTANCE BETWEEN DOORWAYS

(12" MINIMUM IS PREFERRED, 10" MINIMUM IS ACCEPTABLE)

**NORTH CAROLINA PROFESSIONAL ENGINEER ROBERT L. LUEBBERS**

8/06/2019

SHEET 4 OF 4

# STANDARD CARPORT DETAILS 12 ft to 24 ft SPA

**TABLE 1**  
BOW/RAFTER FRAME, END POST, GROUND ANCHOR AND PANEL FASTENER SPACING SPECIFICATIONS

WIND EXPOSURE CATEGORY	ULTIMATE WIND SPEED (MPH)	NOMINAL WIND SPEED (MPH)	MAXIMUM GROUND SNOW LOAD (PSF)	MAXIMUM POST/RAFTER SPACING (FEET)	AVERAGE FASTENER SPACING ON-CENTERS ALONG RAFTERS OR PURLINS, AND POSTS OR GIRTS (INCHES)	
					METAL PANELS	SPACING
B OR C	105 TO 140	85 TO 112	35	5.0	29 Gauge	8
			65	4.0		

NOTES: 1. Specifications applicable to 29 gauge metal panels fastened directly to 12 or 14 gauge steel tube bow frames.  
2. Fasteners consist of #12 x 3/4" self-drilling screws with control seal washers.  
3. Specifications applicable only for mean roof height of 24 feet or less and roof slopes of 7 to 27 degrees (1.5:12 to 6:12 pitch). Spacing requirements for other roof heights and/or slopes may vary.

**TABLE 1 (HIGH WIND REGION)**  
BOW/RAFTER FRAME, END POST, GROUND ANCHOR AND PANEL FASTENER SPACING SPECIFICATIONS

WIND EXPOSURE CATEGORY	ULTIMATE WIND SPEED (MPH)	NOMINAL WIND SPEED (MPH)	MAXIMUM GROUND SNOW LOAD (PSF)	MAXIMUM POST/RAFTER SPACING (FEET)	AVERAGE FASTENER SPACING ON-CENTERS ALONG RAFTERS OR PURLINS, AND POSTS OR GIRTS (INCHES)	
					METAL PANELS	SPACING
B OR C	141 TO 150	113 TO 121	30	5.0	29 Gauge	8
B, C OR D	151 TO 170	122 TO 136	20	4.0	26 Gauge	6

NOTES: 1. Specifications applicable to 29 gauge and 26 gauge metal panels fastened directly to 12 or 14 gauge steel tube bow frames.  
2. Fasteners consist of #12 x 3/4" self-drilling screws with control seal washer.  
3. Specifications applicable only for mean roof height of 24 feet or less and roof slopes of 7 to 27 degrees (1.5:12 to 6:12 pitch). Spacing requirements for other roof heights and/or slopes may vary.



**GENERAL NOTES:**

THESE PLANS PERTAIN ONLY TO THE STRUCTURE, INCLUDING MAIN WIND FORCE RESISTING SYSTEM (MWFRS), COMPONENTS AND CLADDING, AND BASE RAIL ANCHORAGE. OTHER DESIGN ISSUES, INCLUDING, BUT NOT LIMITED TO, PLUMBING, ELECTRICAL, INGRESS/EGRESS, PROPERTY SET-BACKS, OR OTHER LOCAL ZONING REQUIREMENTS ARE THE RESPONSIBILITY OF OTHERS.

THESE STRUCTURES ARE DESIGNED AS UTILITY/STORAGE BUILDINGS CAPABLE OF SUPPORTING THE DEAD LOAD OF THE STRUCTURE AND APPLICABLE LIVE AND WIND LOADS. IMPROVEMENTS NOT SPECIFICALLY ADDRESSED HEREIN, WHICH EXERT ADDITIONAL LOADS ON THE STRUCTURE SHALL BE AT THE OWNER'S RISK. CAROLINA CARPORTS SHALL NOT BE RESPONSIBLE FOR STRUCTURAL DAMAGE OR FAILURE DUE TO THE APPLICATION OF ADDITIONAL LOADS.

ALL STEEL TUBING SHALL BE 55 KSI STEEL OR BETTER. ALL METAL PANELS SHALL BE 80 KSI STEEL OR BETTER.

FASTEN METAL ROOF AND WALL PANELS TO FRAMING WITH #12" x 3/4" SELF DRILLING FASTENERS WITH CONTROL SEAL

NOTE: USE  2 1/2" x 2 1/2" 14 Ga.  
 2 1/4" x 2 1/4" 12 Ga.  
STEEL TUBE FOR ALL FRAME AND BASE RAIL MEMBERS UNLESS OTHERWISE SHOWN.

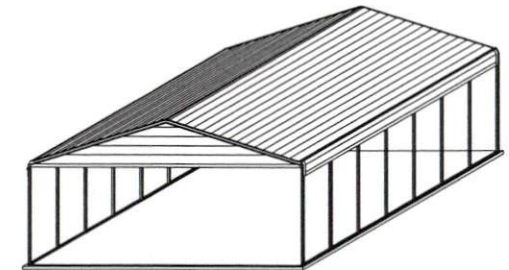

ISOMETRIC

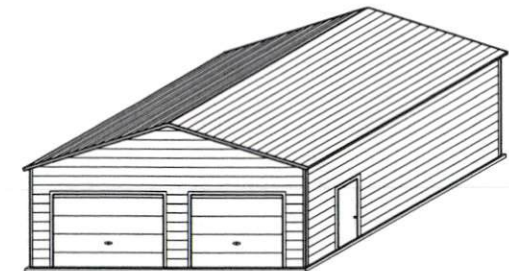

ISOMETRIC

CONCRETE FOUNDATION DESIGN RECOMMENDATIONS:

TOP BRACE LENGTH: USE 2'-0" FOR 12' TO 18' SPANS  
 USE 4'-0" FOR 20' SPAN  
 USE 6'-0" FOR 22' TO 24' SPANS

NOTE: SEE TABLE 1 FOR  
 SIZE & SPACING OF  
 STEEL TUBE FRAME

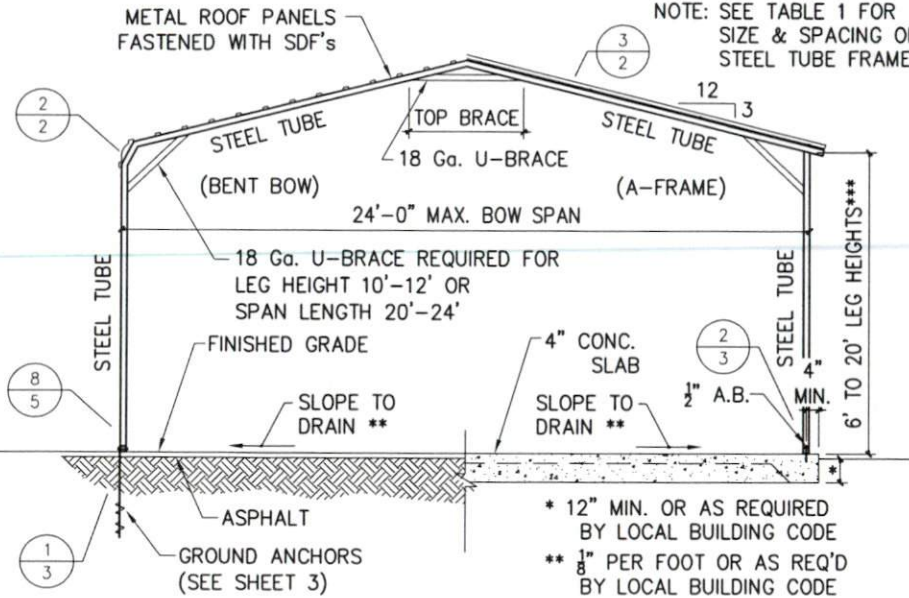

(1/2) TYPICAL BOW SECTION

\* 12" MIN. OR AS REQUIRED  
 BY LOCAL BUILDING CODE  
 \*\* 1/8" PER FOOT OR AS REQ'D  
 BY LOCAL BUILDING CODE

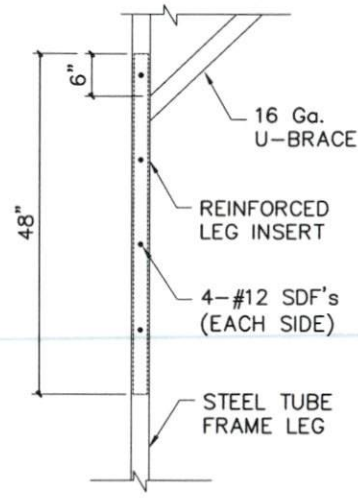

\*\*\* REINFORCED  
 LEG INSERT  
 (LEG HEIGHTS >12' to 14')

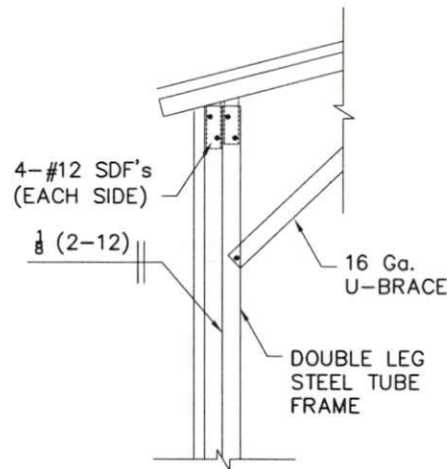

\*\*\* DOUBLE LEG  
 (LEG HEIGHTS >12' to 16')

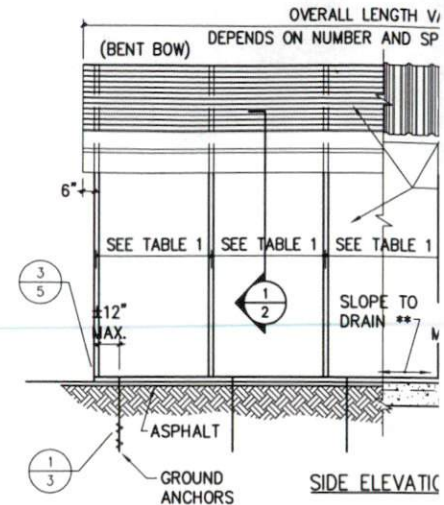
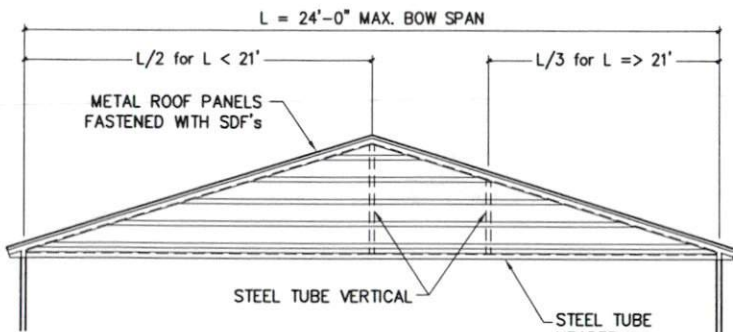

SIDE ELEVATION

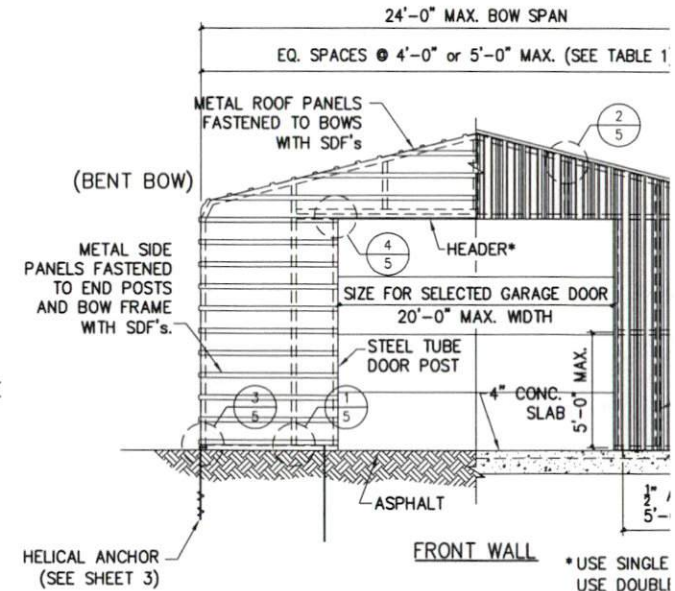

\* USE SINGLE  
 USE DOUBLE

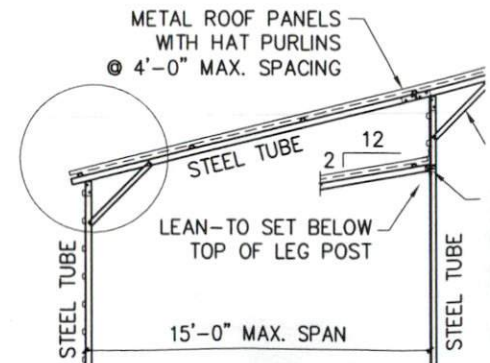
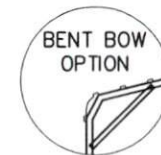
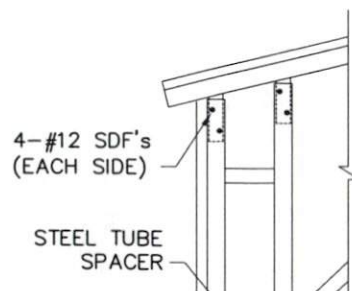

DRILL  $\frac{5}{8}$ " HOLE THROUGH THE BASE RAIL AND SECURE TO ANCHOR EYE WITH  $\frac{1}{2}$ "  $\phi$  THROUGH BOLT

STEEL TUBE BASE RAIL

2" WASHERS

**SOIL CLASSIFICATIONS \***

SOIL CLASS	SOIL DESCRIPTION
2	Very dense &/or cemented sands, coarse gravel and cobbles, caliche, preloaded silts, and clays.
3	Medium dense coarse sands, sandy gravels, very stiff silts, and clays.
4	Loose to medium dense sands, firm to stiff clays and silts alluvial fill and VERY loose to medium dense sands, firm to stiff clays and silts, alluvial fill.

THE HELICAL ANCHOR SHALL BE APPROVED FOR USE IN SOIL CLASSIFICATIONS 2, 3, AND 4.

\* Taken from HUD "Standard for Installation of Mobile Homes"

GROUND ANCHOR  $\frac{3}{4}$ " x 30" WITH 2 - 4" HELIX AND  $\frac{3}{4}$ " EYE BOLT OR OTHER APPROVED HELICAL ANCHOR (THE MAXIMUM ALLOWABLE LOAD IS 3,150 LBS PER ANCHOR)

DRILL  $\frac{5}{8}$ " HOLE THROUGH THE BASE RAIL AND SECURE TO ANCHOR EYE WITH  $\frac{1}{2}$ "  $\phi$  THROUGH BOLT

STEEL TUBE BASE RAIL

2" WASHERS

FINISHED GRADE

CONCRETE SLAB (BY OTHERS)  
COMPACTED SUBGRADE

GROUND ANCHOR  $\frac{3}{4}$ " x 30" WITH 2 - 4" HELIX AND  $\frac{3}{4}$ " EYE BOLT OR OTHER APPROVED HELICAL ANCHOR (THE MAXIMUM ALLOWABLE LOAD IS 3,150 LBS PER ANCHOR)

**1** SOIL BASE RAIL ANCHOR DETAIL

NOTE: IF THE DISTANCE BETWEEN HELICAL ANCHORS EXCEEDS 25', PROVIDE AN ADDITIONAL HELICAL ANCHOR MIDWAY BETWEEN.

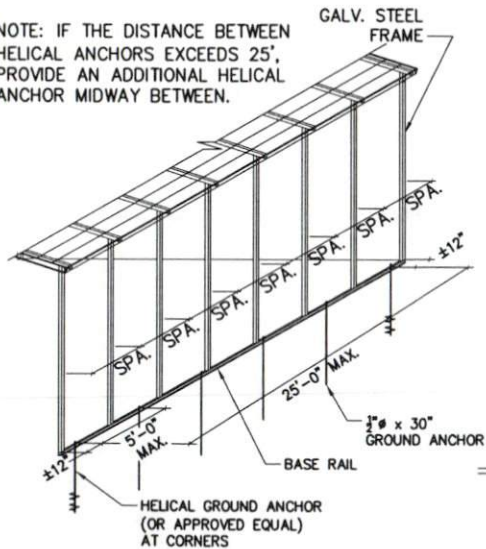

HELICAL GROUND ANCHORS

NOTE: SEE TABLE 1 FOR SIZE & SPACING OF STEEL TUBE FRAME

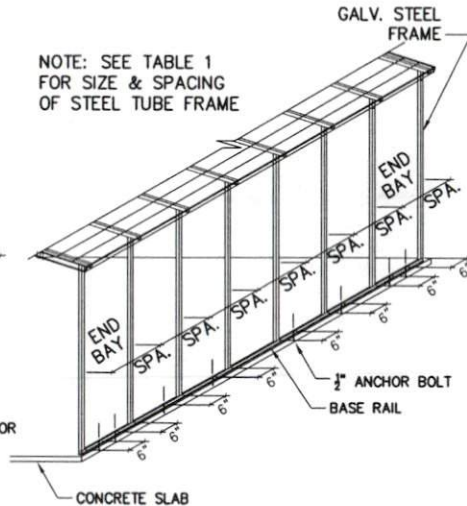

ANCHOR BOLTS

**2** ALTERNATE BASE RAIL ANCHORAGE

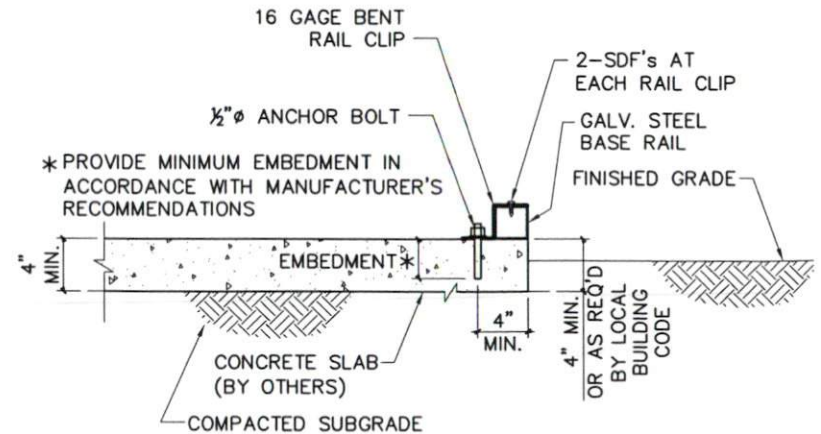

**2** ALTERNATE BASE RAIL ANCHORAGE

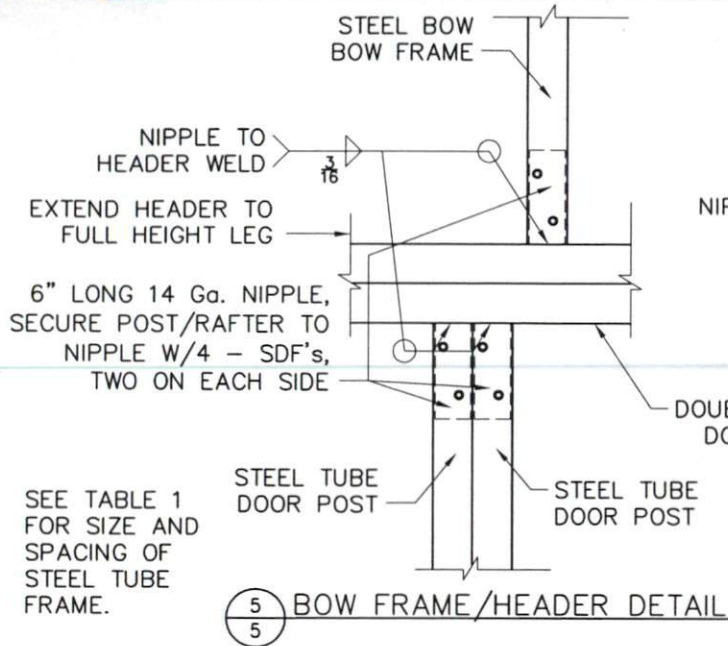

5 BOW FRAME/HEADER DETAIL

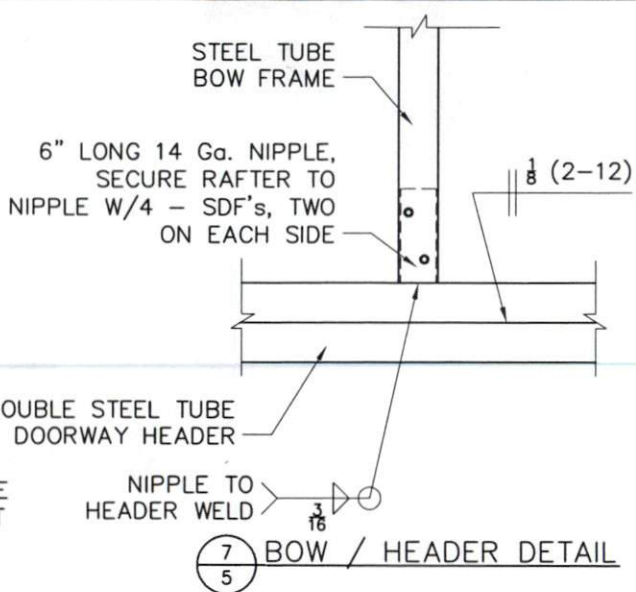

7 BOW / HEADER DETAIL

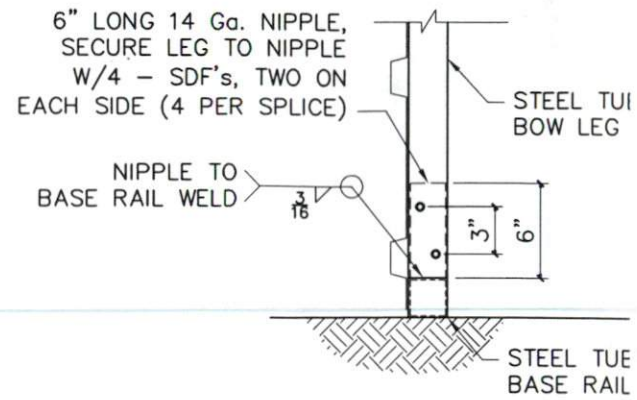

8 BOW/BASE RAIL CONNECTION DETAIL

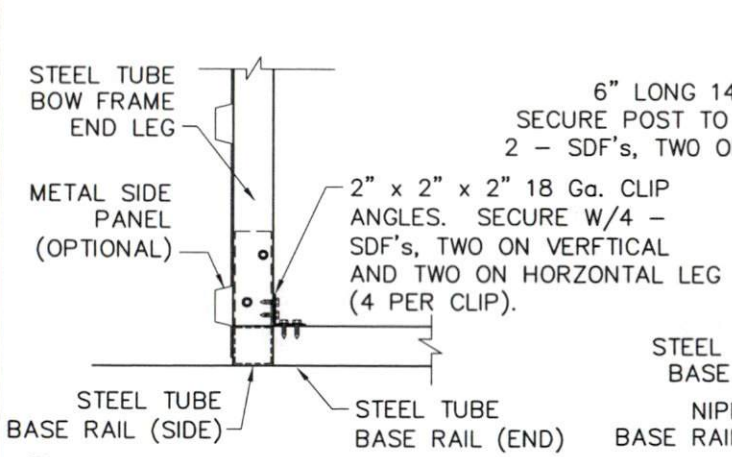

3 END BOW/BASE RAIL CONNECTION

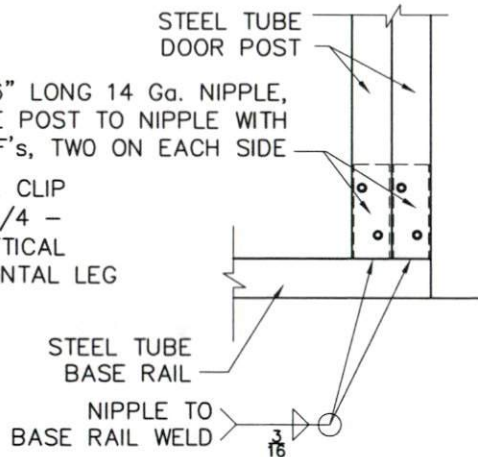

6 POST/BASE RAIL DETAIL

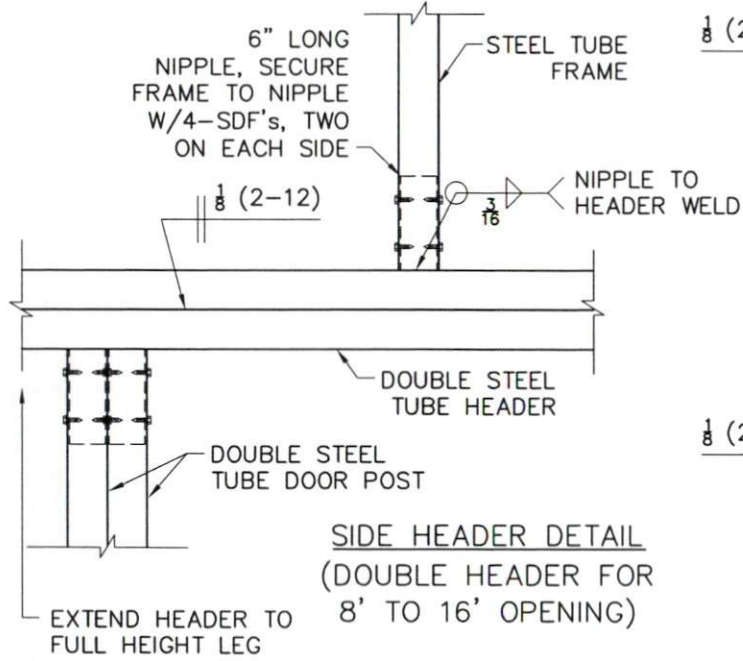

9 SIDE HEADER DETAIL (DOUBLE HEADER FOR 8' TO 16' OPENING)

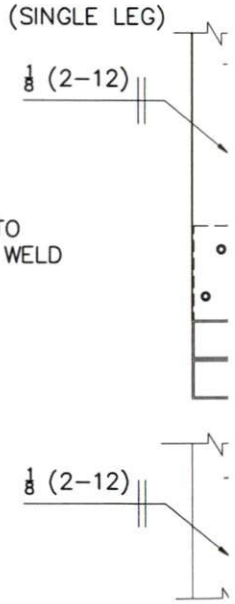

10 HEADER (ONE FOR SINGLE LEG, TWO FOR DOUBLE LEG AND LA)

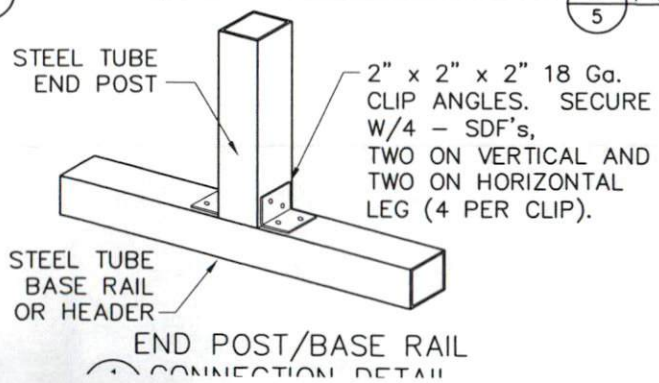

11 END POST/BASE RAIL CONNECTION DETAIL

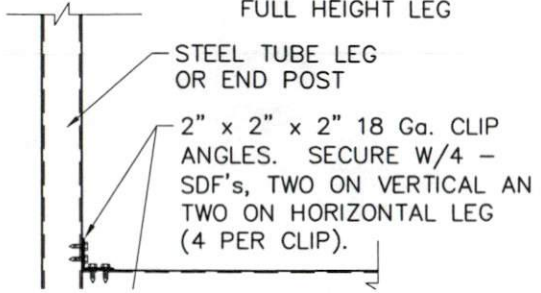

12 STEEL TUBE LEG OR END POST

NIPPLE TO BOW