



Buildings & Garages

Pilot Mountain, North Carolina

STRUCTURAL DESIGN
ENCLOSED BUILDING

**MAXIMUM 30'-0" WIDE X 16'-0" EAVE HEIGHT-
BOX EAVE FRAME**

2 September 2020

Revision 4

M&A Project No. 18184S/18348S/19129S/20229S

Prepared for:

JR Buildings and Garages

316 Nelson Street

Pilot Mountain, NC 27041

Prepared by:

**Moore and Associates Engineering
and Consulting, Inc.**

1009 East Avenue

North Augusta, SC 29841

401 S. Main St., Suite 200

Mount Airy, NC 27030



MOORE AND ASSOCIATES
ENGINEERING AND CONSULTING

**MOORE AND ASSOCIATES
ENGINEERING AND CONSULTING, INC.**

DRAWN BY: LT

CHECKED BY: PH

PROJECT MGR: WSM

CLIENT: JR BUILDINGS

JR BUILDINGS & GARAGES
316 NELSON STREET
PILOT MOUNTAIN, NC 27041
30'-0"x16'-0" ENCLOSED STRUCTURE

DATE: 9-2-20

SHT. 1

SCALE: NTS

DWG. NO: SK-3

JOB NO: 18184S/
18348S/19129S/20229S

REV: 4

THIS DOCUMENT IS THE PROPERTY OF MOORE AND ASSOCIATES ENGINEERING AND CONSULTING. THE UNAUTHORIZED REPRODUCTION, COPYING, OR OTHERWISE USE OF THIS DOCUMENT IS STRICTLY PROHIBITED AND ANY INFRINGEMENT THEREUPON MAY BE SUBJECT TO LEGAL ACTION.

DRAWING INDEX

SHEET 1	PE SEAL COVER SHEET
SHEET 2	DRAWING INDEX
SHEET 3	INSTALLATION NOTES AND SPECIFICATIONS
SHEET 4	TYPICAL SIDE AND END ELEVATIONS
SHEET 5	TYPICAL RAFTER/COLUMN FRAME END AND SIDE FRAMING SECTION (BOX EAVE STRUCTURE)
SHEET 5A	TYPICAL RAFTER/COLUMN FRAME END AND SIDE FRAMING SECTION (BOX EAVE STRUCTURE)
SHEET 6	COLUMN CONNECTION DETAILS (BOX EAVE STRUCTURE)
SHEET 7	TYPICAL RAFTER/COLUMN FRAME END AND SIDE FRAMING SECTION (BOW EAVE STRUCTURE)
SHEET 7A	TYPICAL RAFTER/COLUMN FRAME END AND SIDE FRAMING SECTION (BOW EAVE STRUCTURE)
SHEET 8	COLUMN CONNECTION DETAILS (BOW EAVE STRUCTURE)
SHEET 9	BASE RAIL ANCHORAGE OPTIONS
SHEET 9A	BASE RAIL ANCHORAGE OPTIONS
SHEET 10	BOX EAVE RAFTER END WALL AND SIDE WALL OPENINGS
SHEET 11	BOW EAVE RAFTER END WALL AND SIDE WALL OPENINGS
SHEET 12	CONNECTION DETAILS
SHEET 13	CONNECTION DETAILS
SHEET 14	LEAN-TO OPTIONS (BOX EAVE STRUCTURE)
SHEET 15	LEAN-TO OPTIONS (BOW EAVE STRUCTURE)
SHEET 16	BOX EAVE RAFTER VERTICAL ROOF/SIDING OPTION
SHEET 16A	BOX EAVE RAFTER VERTICAL ROOF/SIDING OPTION
SHEET 17	SIDE WALL AND END WALL HEADER OPTIONS

**MOORE AND ASSOCIATES
ENGINEERING AND CONSULTING, INC.**

DRAWN BY: LT

CHECKED BY: PH

PROJECT MGR: WSM

CLIENT: JR BUILDINGS

**JR BUILDINGS & GARAGES
316 NELSON STREET
PILOT MOUNTAIN, NC 27041
30'-0"x16'-0" ENCLOSED STRUCTURE**

DATE: 9-2-20

SCALE: NTS

SHT. 2

DWG. NO: SK-3

**JOB NO: 18184S/
18348S/19129S/20229S**

REV: 4

THIS DOCUMENT IS THE PROPERTY OF MOORE AND ASSOCIATES ENGINEERING AND CONSULTING. THE UNAUTHORIZED REPRODUCTION, COPYING, OR OTHERWISE USE OF THIS DOCUMENT IS STRICTLY PROHIBITED AND ANY INFRINGEMENT THEREUPON MAY BE SUBJECT TO LEGAL ACTION.

INSTALLATION NOTES AND SPECIFICATIONS

1. DESIGN IS FOR MAXIMUM 30'-0" WIDE x 16'-0" EAVE HEIGHT ENCLOSED STRUCTURES.
2. DESIGN WAS DONE IN ACCORDANCE WITH THE 2018 NORTH CAROLINA BUILDING CODE, 2018 INTERNATIONAL BUILDING CODE (IBC), 2015 IBC, 2012 IBC AND 2009 IBC.
3. DESIGN LOADS ARE AS FOLLOWS:
 - A) DEAD LOAD = 1.5 PSF
 - B) LIVE LOAD = 12 PSF
 - C) GROUND SNOW LOAD = 35 PSF
 - = 30 PSF (W ≤ 24'-0" WITH U-CHANNEL COLLAR TIE)
 - * DIFFERENTIAL LOADING DUE TO SNOW DRIFT NOT ANALYZED.
4. ULTIMATE 3-SECOND GUST WIND SPEED (V_{ULT}) = ≤ 145 MPH (NOMINAL WIND SPEED = ≤ 112 MPH).
5. MAXIMUM RAFTER/COLUMN AND END COLUMN SPACING = 5.0 FEET (UNLESS NOTED OTHERWISE).
6. END WALL COLUMNS/POSTS AND SIDEWALL COLUMNS/POSTS AND ARE SIMILAR IN SIZE AND SPACING (UNLESS NOTED OTHERWISE).
7. RISK CATEGORY I.
8. WIND EXPOSURE CATEGORY B.
9. SPECIFICATIONS APPLICABLE TO 29 GAUGE METAL PANELS FASTENED DIRECTLY TO 2 1/2" x 2 1/2" - 14 GAUGE TUBE STEEL (TS) FRAMING MEMBERS (UNLESS NOTED OTHERWISE).
10. AVERAGE FASTENER SPACING ON-CENTERS ALONG RAFTERS OR HAT CHANNELS, AND COLUMNS (INTERIOR OR END) = 8 INCHES.
11. FASTENERS CONSIST OF #12-14x3/4" SELF-DRILLING FASTENER (SDF), USE CONTROL SEAL WASHER WITH EXTERIOR FASTENERS. SPECIFICATIONS APPLICABLE ONLY FOR MEAN ROOF HEIGHT OF 16 FEET OR LESS, AND ROOF SLOPES OF 14° (3:12 PITCH) OR LESS SPACING REQUIREMENTS FOR OTHER ROOF HEIGHTS AND/OR SLOPES MAY VARY. ROOF SLOPES LESS THAN 3:12 REQUIRE USE OF LAP JOINT SEALANT.
12. GROUND ANCHORS SHALL BE INSTALLED THROUGH BASE RAIL WITHIN 6" OF EACH COLUMN.
13. STANDARD GROUND ANCHORS (SOIL NAILS) CONSIST OF #4 REBAR W/ WELDED NUT x 30" LONG. SOIL NAILS MAY BE USED FOR WIND SPEEDS ≤ 145 MPH AND IN SUITABLE SOIL CONDITIONS. OPTIONAL ANCHORAGE MAY BE USED IN SUITABLE SOILS AND MUST BE USED IN UNSUITABLE SOILS AS NOTED. COORDINATE WITH LOCAL CODES/ORDINANCES REGARDING MINIMUM LENGTH FOR FROST DEPTH PROTECTION.
14. WIND FORCES GOVERN OVER SEISMIC FORCES. SEISMIC PARAMETERS ANALYZED ARE:
 - SOIL SITE CLASS = D
 - RISK CATEGORY I
 - R = 3.25 I_E = 1.0
 - S_{DS} = 2.039 g V = C_sW
 - S_{D1} = 1.258 g

MOORE AND ASSOCIATES ENGINEERING AND CONSULTING, INC.	DRAWN BY: LT	JR BUILDINGS & GARAGES 316 NELSON STREET PILOT MOUNTAIN, NC 27041 30'-0"x16'-0" ENCLOSED STRUCTURE		
	CHECKED BY: PH			
THIS DOCUMENT IS THE PROPERTY OF MOORE AND ASSOCIATES ENGINEERING AND CONSULTING. THE UNAUTHORIZED REPRODUCTION, COPYING, OR OTHERWISE USE OF THIS DOCUMENT IS STRICTLY PROHIBITED AND ANY INFRINGEMENT THEREUPON MAY BE SUBJECT TO LEGAL ACTION.	PROJECT MGR: WSM	DATE: 9-2-20	SCALE: NTS	JOB NO: 18184S/ 18348S/19129S/20229S
	CLIENT: JR BUILDINGS	SHT. 3	DWG. NO: SK-3	REV.: 4

BOX EAVE FRAME RAFTER STRUCTURE

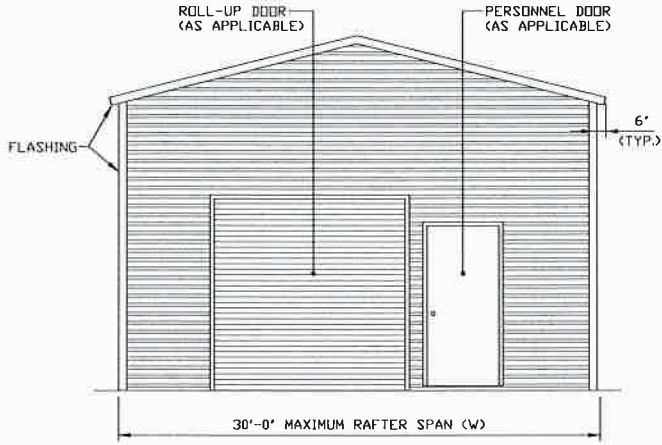

TYPICAL END ELEVATION

SCALE: NTS

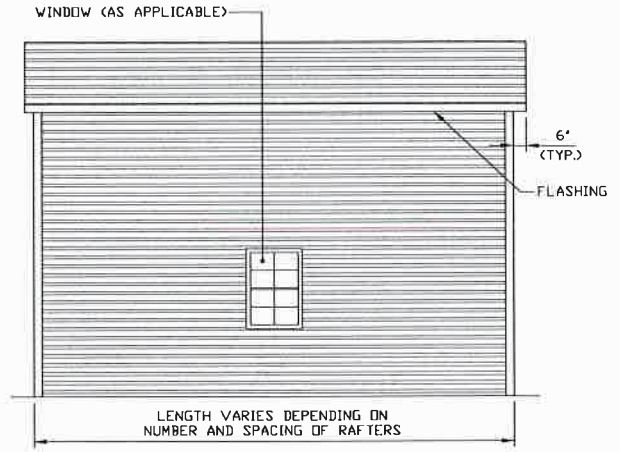

TYPICAL SIDE ELEVATION

SCALE: NTS

BOW EAVE FRAME RAFTER STRUCTURE

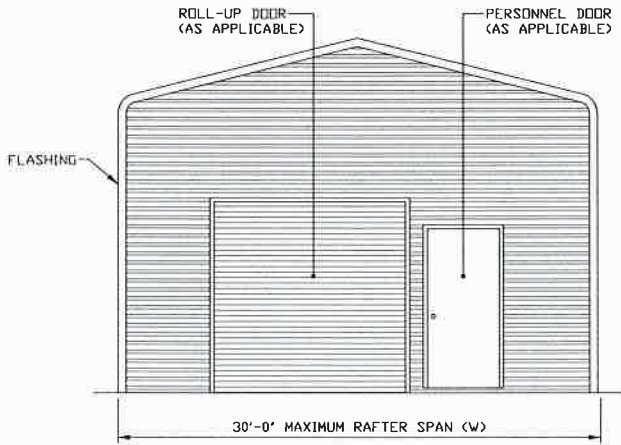

TYPICAL END ELEVATION

SCALE: NTS

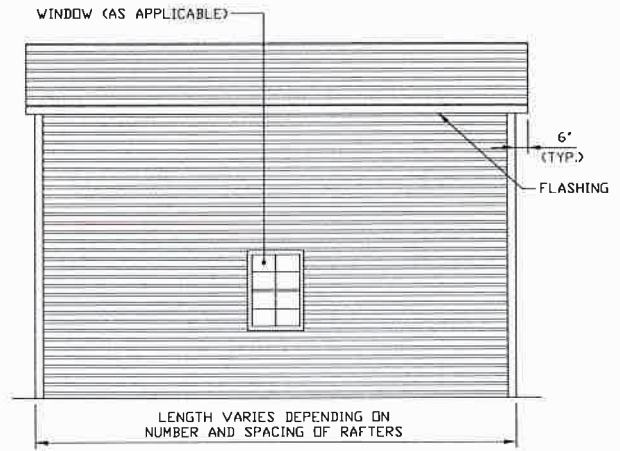

TYPICAL SIDE ELEVATION

SCALE: NTS

**MOORE AND ASSOCIATES
ENGINEERING AND CONSULTING, INC.**

THIS DOCUMENT IS THE PROPERTY OF MOORE AND ASSOCIATES ENGINEERING AND CONSULTING. THE UNAUTHORIZED REPRODUCTION, COPYING, OR OTHERWISE USE OF THIS DOCUMENT IS STRICTLY PROHIBITED AND ANY INFRINGEMENT THEREUPON MAY BE SUBJECT TO LEGAL ACTION.

DRAWN BY: LT

CHECKED BY: PH

PROJECT MGR: WSM

CLIENT: JR BUILDINGS

JR BUILDINGS & GARAGES
316 NELSON STREET
PILOT MOUNTAIN, NC 27041
30'-0"x16'-0" ENCLOSED STRUCTURE

DATE: 9-2-20

SHT. 4

SCALE: NTS

DWG. NO: SK-3

JOB NO: 18184S/
18348S/19129S/20229S

REV: 4

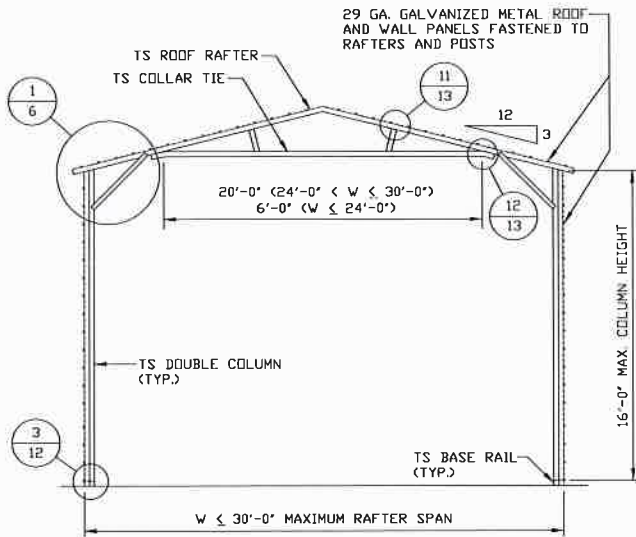

TYPICAL RAFTER/COLUMN FRAME SECTION
SCALE: NTS

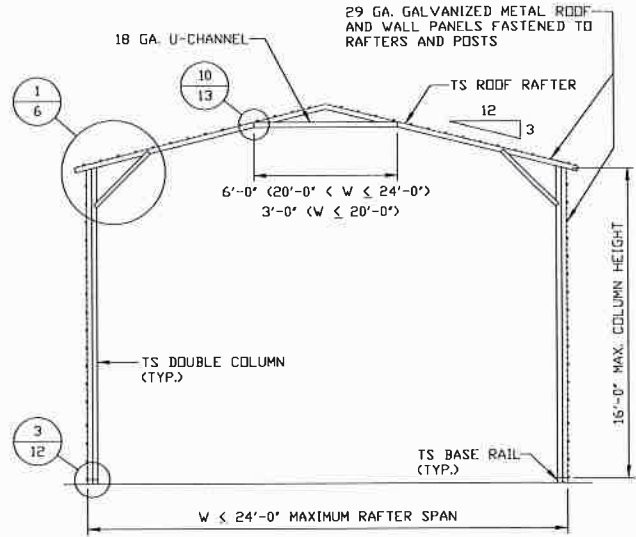

TYPICAL RAFTER/COLUMN FRAME SECTION
SCALE: NTS

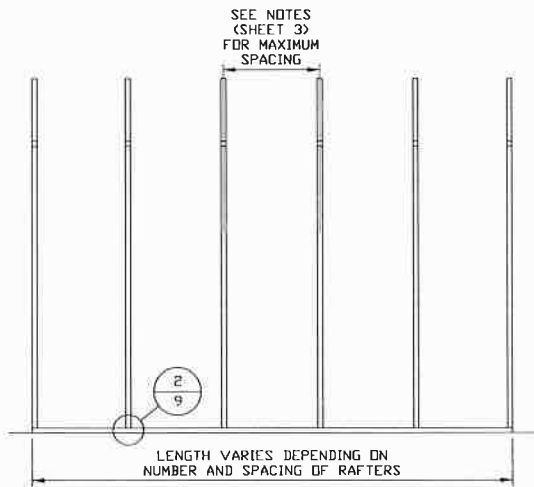

TYPICAL RAFTER/COLUMN SIDE FRAMING SECTION
SCALE: NTS

**MOORE AND ASSOCIATES
ENGINEERING AND CONSULTING, INC.**

DRAWN BY: LT

CHECKED BY: PH

PROJECT MGR: WSM

CLIENT: JR BUILDINGS

**JR BUILDINGS & GARAGES
316 NELSON STREET
PILOT MOUNTAIN, NC 27041
30'-0" x 16'-0" ENCLOSED STRUCTURE**

DATE: 9-2-20

SHT. 5

SCALE: NTS

DWG. NO: SK-3

**JOB NO: 18184S/
18348S/19129S/20229S**

REV: 4

THIS DOCUMENT IS THE PROPERTY OF MOORE AND ASSOCIATES ENGINEERING AND CONSULTING. THE UNAUTHORIZED REPRODUCTION, COPYING, OR OTHERWISE USE OF THIS DOCUMENT IS STRICTLY PROHIBITED AND ANY INFRINGEMENT THEREUPON MAY BE SUBJECT TO LEGAL ACTION.

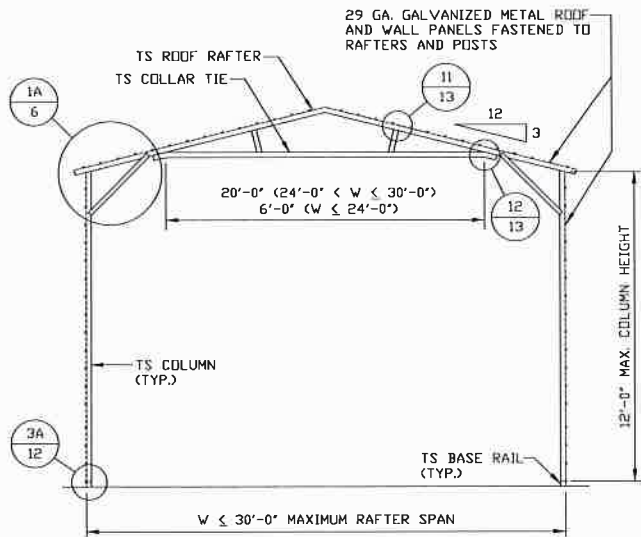

TYPICAL RAFTER/COLUMN FRAME SECTION
SCALE: NTS

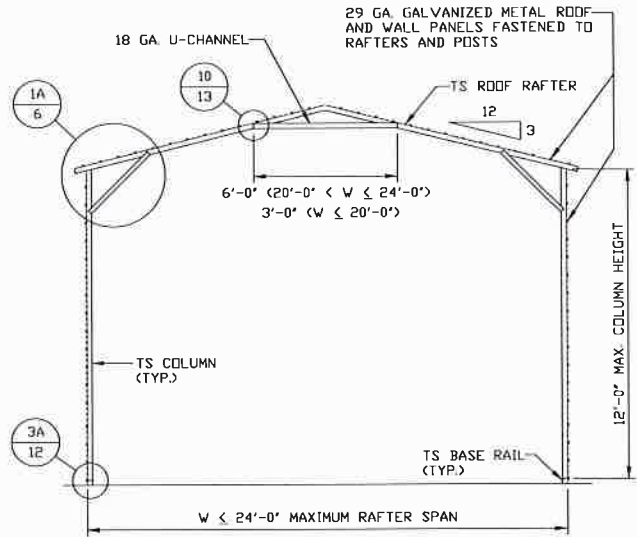

TYPICAL RAFTER/COLUMN FRAME SECTION
SCALE: NTS

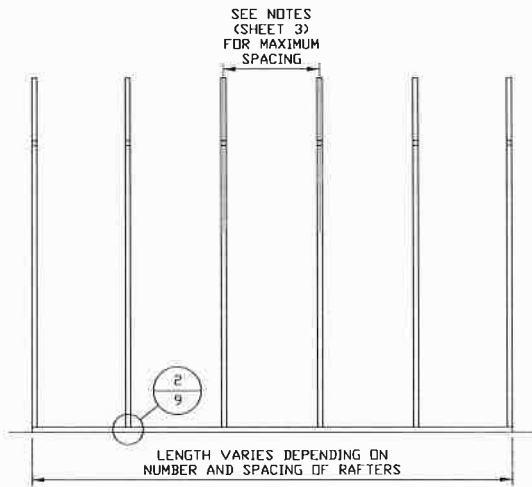

TYPICAL RAFTER/COLUMN SIDE FRAMING SECTION
SCALE: NTS

**MOORE AND ASSOCIATES
ENGINEERING AND CONSULTING, INC.**

THIS DOCUMENT IS THE PROPERTY OF MOORE AND ASSOCIATES ENGINEERING AND CONSULTING. THE UNAUTHORIZED REPRODUCTION, COPYING, OR OTHERWISE USE OF THIS DOCUMENT IS STRICTLY PROHIBITED AND ANY INFRINGEMENT THEREUPON MAY BE SUBJECT TO LEGAL ACTION.

DRAWN BY: LT

CHECKED BY: PH

PROJECT MGR: VSM

CLIENT: JR BUILDINGS

JR BUILDINGS & GARAGES
316 NELSON STREET
PILOT MOUNTAIN, NC 27041
30'-0" x 16'-0" ENCLOSED STRUCTURE

DATE: 9-2-20

SHT. 5A

SCALE: NTS

DWG. NO: SK-3

JOB NO: 18184S/
18348S/19129S/20229S

REV.: 4

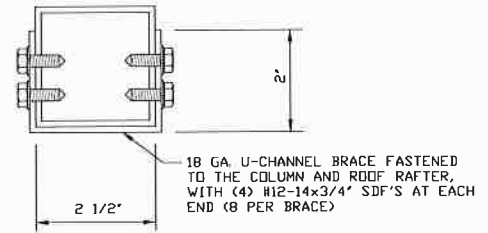
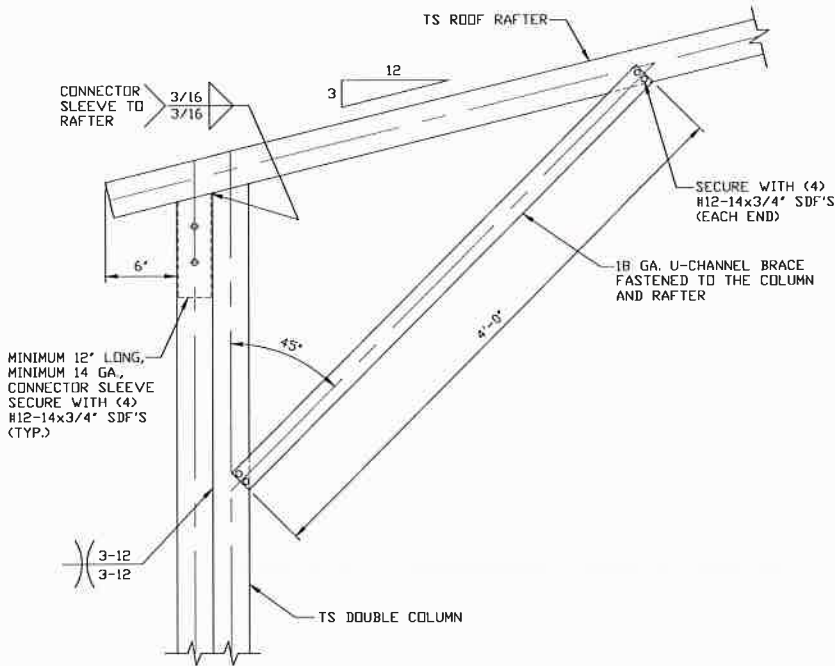

BRACE SECTION
SCALE: NTS

1
BOX EAVE RAFTER/CORNER POST CONNECTION DETAIL
FOR HEIGHTS 12'-0" < TO ≤ 16'-0"
SCALE: NTS
NOTE: 2'-0" KNEE BRACE MAY BE USED FOR BUILDING WIDTHS ≤ 24'-0".

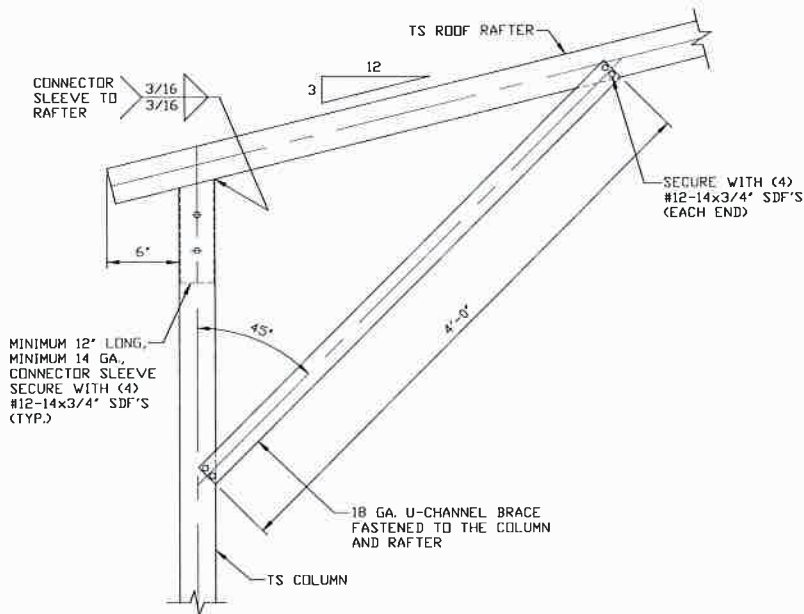

1A
BOX EAVE RAFTER/CORNER POST CONNECTION DETAIL
FOR HEIGHTS ≤ 12'-0"
SCALE: NTS
NOTE: 2'-0" KNEE BRACE MAY BE USED FOR BUILDING WIDTHS ≤ 24'-0" AND ≤ 11'-0" EAVE HEIGHT

**MOORE AND ASSOCIATES
ENGINEERING AND CONSULTING, INC.**

DRAWN BY: LT
CHECKED BY: PH
PROJECT MGR: WSM
CLIENT: JR BUILDINGS

JR BUILDINGS & GARAGES
316 NELSON STREET
PILOT MOUNTAIN, NC 27041
30'-0"x16'-0" ENCLOSED STRUCTURE
DATE: 9-2-20
SCALE: NTS
JOB NO: 18184S/18348S/19129S/20229S
SHT. 6
DWG. NO: SK-3
REV: 4

THIS DOCUMENT IS THE PROPERTY OF MOORE AND ASSOCIATES ENGINEERING AND CONSULTING. THE UNAUTHORIZED REPRODUCTION, COPYING, OR OTHERWISE USE OF THIS DOCUMENT IS STRICTLY PROHIBITED AND ANY INFRINGEMENT THEREUPON MAY BE SUBJECT TO LEGAL ACTION.

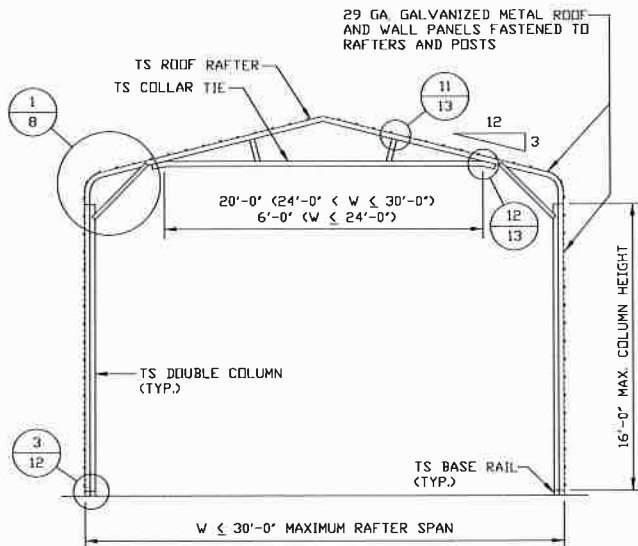

TYPICAL RAFTER/COLUMN FRAME SECTION
SCALE: NTS

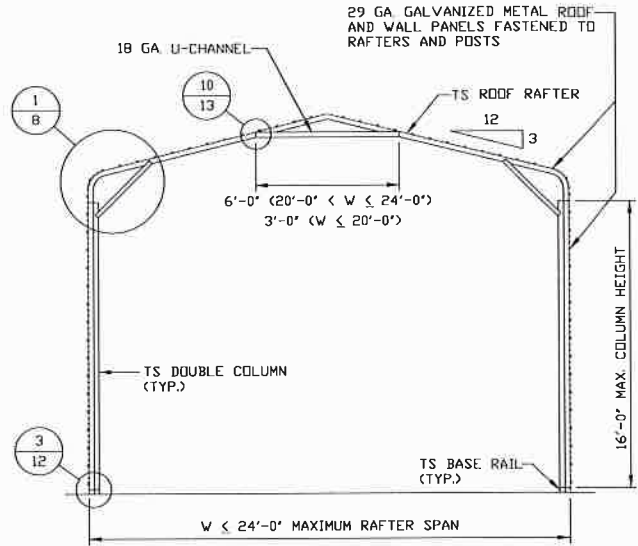

TYPICAL RAFTER/COLUMN FRAME SECTION
SCALE: NTS

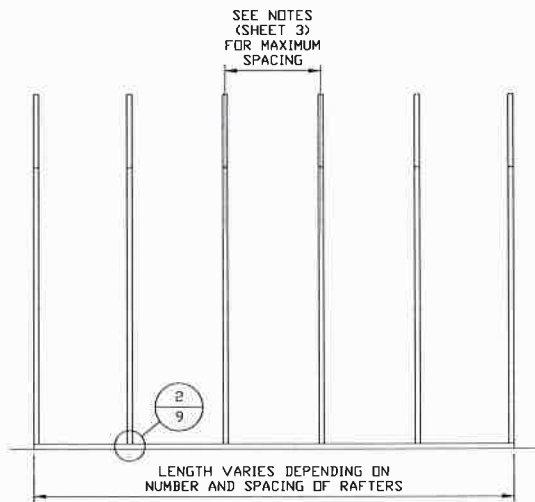

TYPICAL RAFTER/COLUMN SIDE FRAMING SECTION
SCALE: NTS

**MOORE AND ASSOCIATES
ENGINEERING AND CONSULTING, INC.**

THIS DOCUMENT IS THE PROPERTY OF MOORE AND ASSOCIATES ENGINEERING AND CONSULTING. THE UNAUTHORIZED REPRODUCTION, COPYING, OR OTHERWISE USE OF THIS DOCUMENT IS STRICTLY PROHIBITED AND ANY INFRINGEMENT THEREUPON MAY BE SUBJECT TO LEGAL ACTION.

DRAWN BY: LT

CHECKED BY: PH

PROJECT MGR: WSM

CLIENT: JR BUILDINGS

**JR BUILDINGS & GARAGES
316 NELSON STREET
PILOT MOUNTAIN, NC 27041
30'-0" x 16'-0" ENCLOSED STRUCTURE**

DATE: 9-2-20

SHT. 7

SCALE: NTS

DWG. NO: SK-3

**JOB NO: 18184S/
18348S/19129S/20229S**

REV: 4

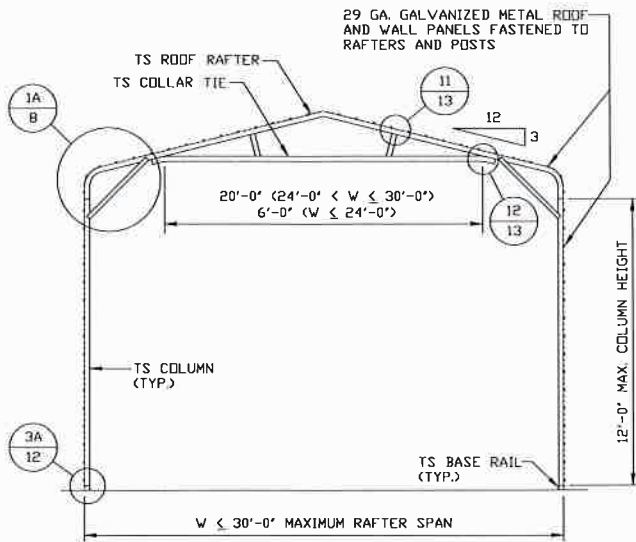

TYPICAL RAFTER/COLUMN FRAME SECTION
SCALE: NTS

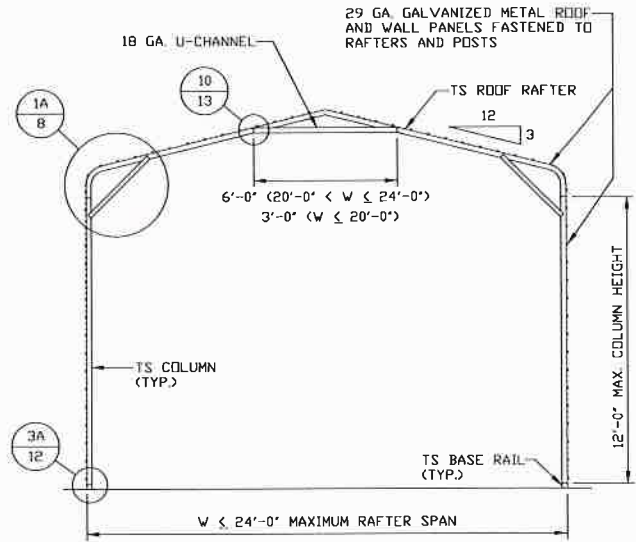

TYPICAL RAFTER/COLUMN FRAME SECTION
SCALE: NTS

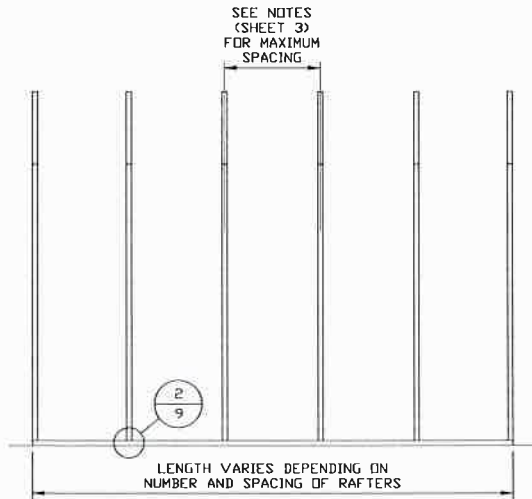

TYPICAL RAFTER/COLUMN SIDE FRAMING SECTION
SCALE: NTS

**MOORE AND ASSOCIATES
ENGINEERING AND CONSULTING, INC.**

DRAWN BY: LT

CHECKED BY: PH

PROJECT MGR: WSM

CLIENT: JR BUILDINGS

JR BUILDINGS & GARAGES
316 NELSON STREET
PILOT MOUNTAIN, NC 27041
30'-0" x 16'-0" ENCLOSED STRUCTURE

DATE: 9-2-20

SHT. 7A

SCALE: NTS

DWG. NO: SK-3

JOB NO: 18184S/
18348S/19129S/20229S

REV.: 4

THIS DOCUMENT IS THE PROPERTY OF MOORE AND ASSOCIATES ENGINEERING AND CONSULTING. THE UNAUTHORIZED REPRODUCTION, COPYING, OR OTHERWISE USE OF THIS DOCUMENT IS STRICTLY PROHIBITED AND ANY INFRINGEMENT THEREUPON MAY BE SUBJECT TO LEGAL ACTION.

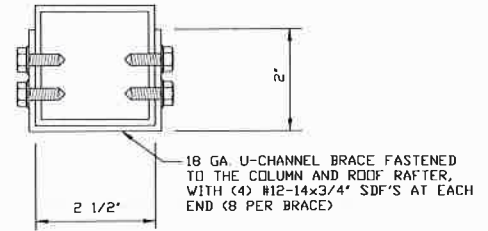
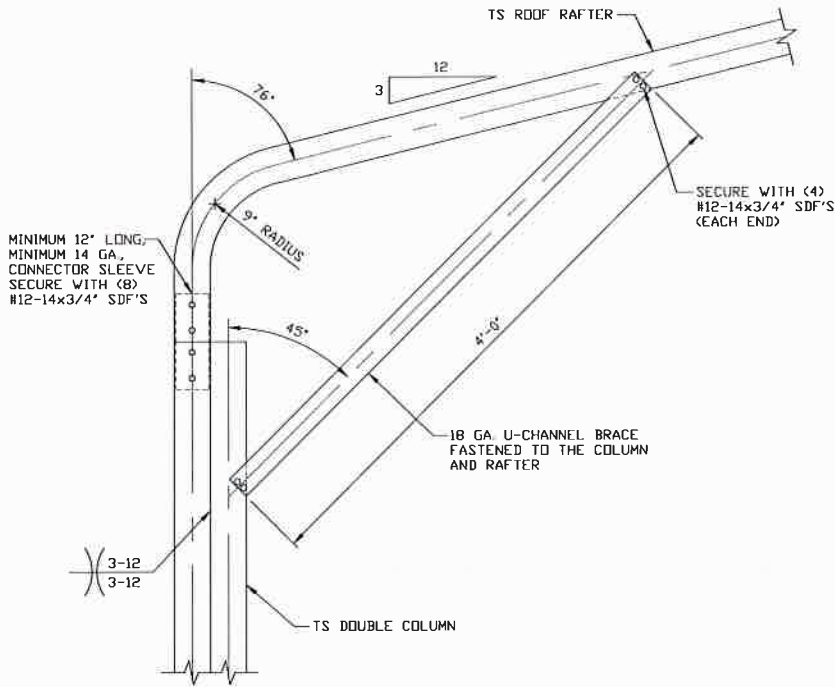

BRACE SECTION
SCALE: NTS

1
BOX EAVE RAFTER/CORNER POST CONNECTION DETAIL FOR HEIGHTS 12'-0" < TO <= 16'-0"
SCALE: NTS
NOTE: 2'-0" KNEE BRACE MAY BE USED FOR BUILDING WIDTHS < 24'-0".

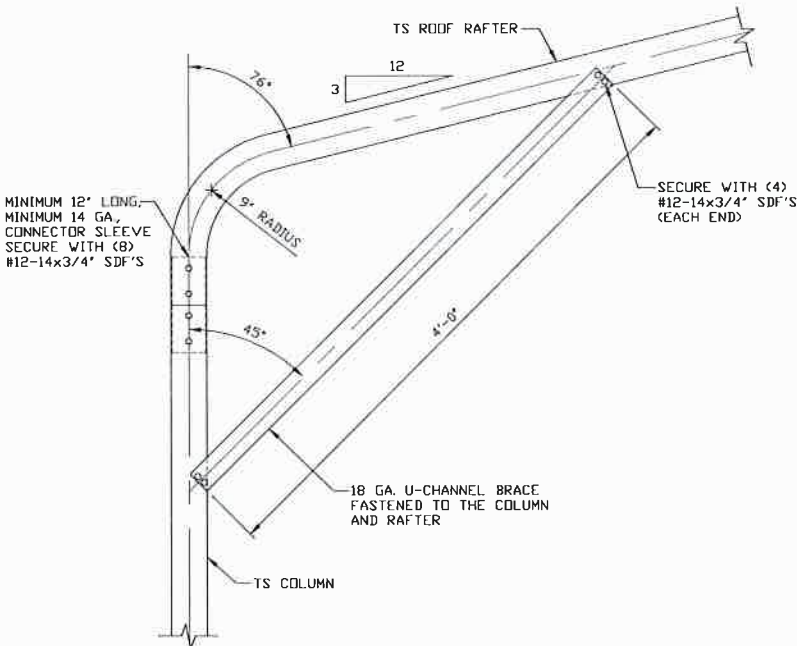

1A
BOX EAVE RAFTER/CORNER POST CONNECTION DETAIL FOR HEIGHTS <= 12'-0"
SCALE: NTS
NOTE: 2'-0" KNEE BRACE MAY BE USED FOR BUILDING WIDTHS < 24'-0" AND <= 11'-0" EAVE HEIGHT

**MOORE AND ASSOCIATES
ENGINEERING AND CONSULTING, INC.**

DRAWN BY: LT

CHECKED BY: PH

PROJECT MGR: WSM

CLIENT: JR BUILDINGS

JR BUILDINGS & GARAGES
316 NELSON STREET
PILOT MOUNTAIN, NC 27041
30'-0"x16'-0" ENCLOSED STRUCTURE

DATE: 9-2-20

SHT. 8

SCALE: NTS

DWG. NO: SK-3

**JOB NO: 18184S/
18348S/19129S/20229S**

REV: 4

THIS DOCUMENT IS THE PROPERTY OF MOORE AND ASSOCIATES ENGINEERING AND CONSULTING. THE UNAUTHORIZED REPRODUCTION, COPYING, OR OTHERWISE USE OF THIS DOCUMENT IS STRICTLY PROHIBITED AND ANY INFRINGEMENT THEREUPON MAY BE SUBJECT TO LEGAL ACTION.

BASE RAIL ANCHORAGE OPTIONS

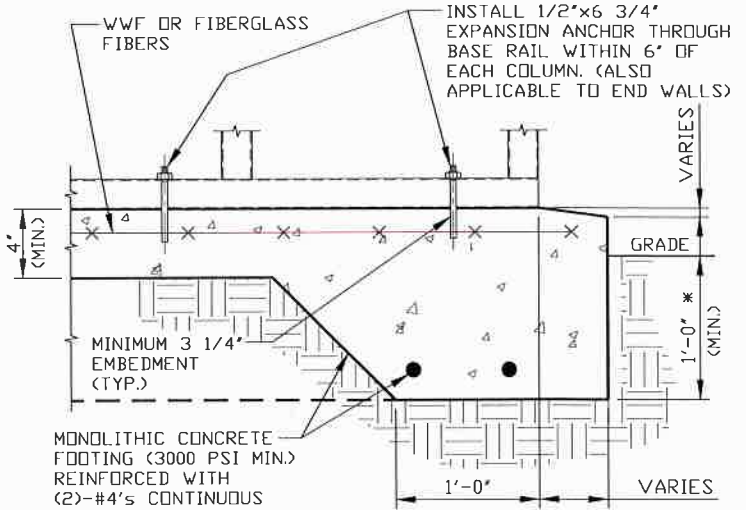
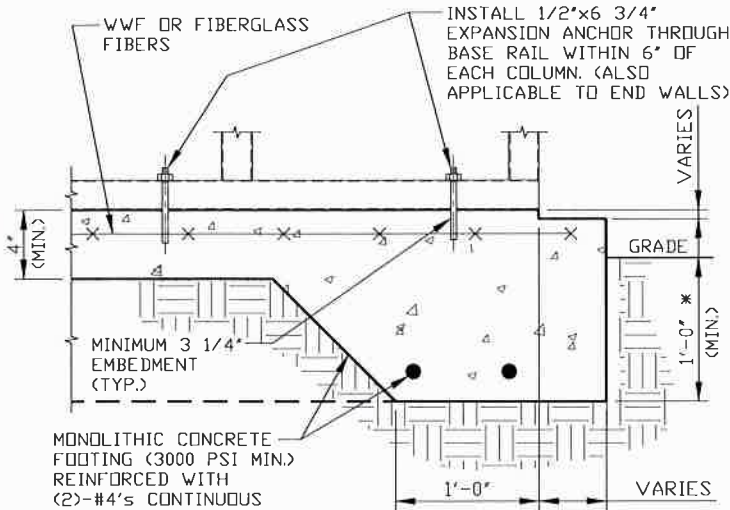

2

CONCRETE MONOLITHIC SLAB BASE RAIL ANCHORAGE

SCALE: NTS
MINIMUM ANCHOR EDGE DISTANCE IS 4".
* COORDINATE WITH LOCAL BUILDING CODE
AND/OR BUILDING OFFICIAL REGARDING
REQUIRED FOOTING DEPTH.

2A

CONCRETE MONOLITHIC SLAB BASE RAIL ANCHORAGE

SCALE: NTS
MINIMUM ANCHOR EDGE DISTANCE IS 4".
* COORDINATE WITH LOCAL BUILDING CODE
AND/OR BUILDING OFFICIAL REGARDING
REQUIRED FOOTING DEPTH.

GENERAL NOTES

NOTE: CONCRETE MONOLITHIC SLAB DESIGN BASED ON MINIMUM SOIL BEARING CAPACITY OF 1,500 PSF.

CONCRETE:

CONCRETE SHALL HAVE A MINIMUM SPECIFIED COMPRESSIVE STRENGTH OF 3,000 PSI AT 28 DAYS.

COVER OVER REINFORCING STEEL:

FOR FOUNDATIONS, MINIMUM CONCRETE COVER OVER REINFORCING BARS SHALL BE PER ACI-318:
3" IN FOUNDATIONS WHERE THE CONCRETE IS CAST AGAINST AND PERMANENTLY IN CONTACT WITH THE EARTH OR EXPOSED TO THE EARTH OR WEATHER, AND 1 1/2" ELSEWHERE.

REINFORCING STEEL:

THE TURNDOWN REINFORCING STEEL SHALL BE ASTM A615 GRADE 60. THE SLAB REINFORCEMENT SHALL BE WELDED WIRE FABRIC MEETING ASTM A185 OR FIBERGLASS FIBER REINFORCEMENT.

REINFORCEMENT MAY BE BENT IN THE SHOP OR THE FIELD PROVIDED:

1. REINFORCEMENT IS BENT COLD.
2. THE DIAMETER OF THE BEND, MEASURED ON THE INSIDE OF THE BAR, IS NOT LESS THAN SIX-BAR DIAMETERS.
3. REINFORCEMENT PARTIALLY EMBEDDED IN CONCRETE SHALL NOT BE FIELD BENT.

HELIX ANCHOR NOTES:

1. FOR VERY DENSE AND/OR CEMENTED SANDS, COARSE GRAVEL AND COBBLES, CALICHE, PRELOADED SILTS AND CLAYS, USE MINIMUM (2) 4" HELICES WITH MINIMUM 30" EMBEDMENT OR SINGLE 6" HELIX WITH MINIMUM 50" EMBEDMENT
2. FOR CORAL USE MINIMUM (2) 4" HELICES WITH MINIMUM 30" EMBEDMENT OR SINGLE 6" HELIX WITH MINIMUM 50" EMBEDMENT.
3. FOR MEDIUM DENSE COARSE SANDS, SANDY GRAVELS, VERY STIFF SILTS, AND CLAYS USE MINIMUM (2) 4" HELICES WITH MINIMUM 30 INCH EMBEDMENT OR SINGLE 6" HELIX WITH MINIMUM 50" EMBEDMENT.
4. FOR LOOSE TO MEDIUM DENSE SANDS, FIRM TO STIFF CLAYS AND SILTS ALLUVIAL FILL, USE MINIMUM (2) 6" HELICES WITH MINIMUM 50" EMBEDMENT.
5. FOR VERY LOSE TO MEDIUM DENSE SANDS, FIRM TO STIFFER CLAYS AND SILTS, ALLUVIAL FILL, USE MINIMUM (2) 8" HELICES WITH MINIMUM 60" EMBEDMENT.

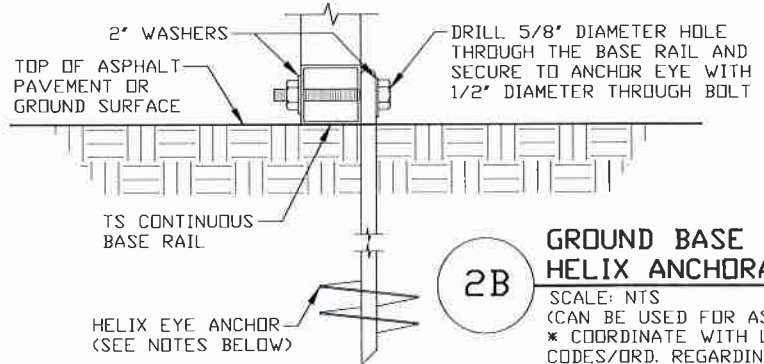

2B

GROUND BASE HELIX ANCHORAGE

SCALE: NTS
(CAN BE USED FOR ASPHALT)
* COORDINATE WITH LOCAL
CODES/ORD. REGARDING MIN.
FROST DEPTH (LENGTH).

**MOORE AND ASSOCIATES
ENGINEERING AND CONSULTING, INC.**

DRAWN BY: LT

CHECKED BY: PH

PROJECT MGR: WSM

CLIENT: JR BUILDINGS

JR BUILDINGS & GARAGES
316 NELSON STREET
PILOT MOUNTAIN, NC 27041
30'-0" x 16'-0" ENCLOSED STRUCTURE

DATE: 9-2-20

SHT. 9

SCALE: NTS

DWG. NO: SK-3

JOB NO: 18184S/
18348S/19129S/20229S

REV: 4

THIS DOCUMENT IS THE PROPERTY OF MOORE AND ASSOCIATES ENGINEERING AND CONSULTING. THE UNAUTHORIZED REPRODUCTION, COPYING, OR OTHERWISE USE OF THIS DOCUMENT IS STRICTLY PROHIBITED AND ANY INFRINGEMENT THEREUPON MAY BE SUBJECT TO LEGAL ACTION.

BASE RAIL ANCHORAGE OPTIONS

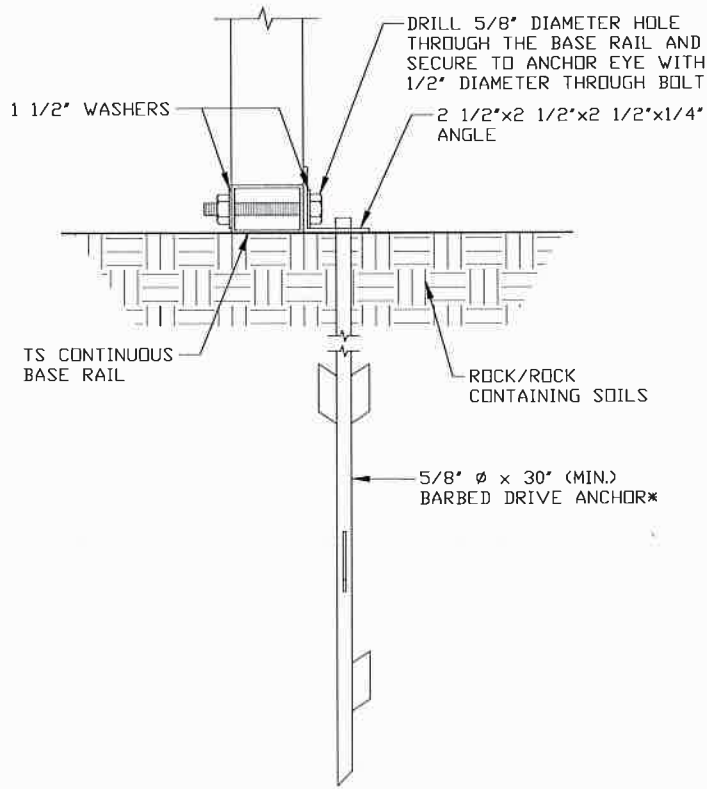

2C

BARBED DRIVE ANCHORAGE

SCALE: NTS
 * COORDINATE WITH LOCAL CODES/ORD.
 REGARDING MINIMUM FROST DEPTH REQ.

**MOORE AND ASSOCIATES
 ENGINEERING AND CONSULTING, INC.**

DRAWN BY: LT

CHECKED BY: PH

PROJECT MGR: WSM

CLIENT: JR BUILDINGS

JR BUILDINGS & GARAGES
 316 NELSON STREET
 PILOT MOUNTAIN, NC 27041
 30'-0" x 16'-0" ENCLOSED STRUCTURE

DATE: 9-2-20

SHT. 9A

SCALE: NTS

DWG. NO: SK-3

**JOB NO: 18184S/
 18348S/19129S/20229S**

REV.: 4

THIS DOCUMENT IS THE PROPERTY OF MOORE AND ASSOCIATES ENGINEERING AND CONSULTING. THE UNAUTHORIZED REPRODUCTION, COPYING, OR OTHERWISE USE OF THIS DOCUMENT IS STRICTLY PROHIBITED AND ANY INFRINGEMENT THEREUPON MAY BE SUBJECT TO LEGAL ACTION.

BOX EAVE RAFTER END WALL AND SIDE WALL OPENINGS

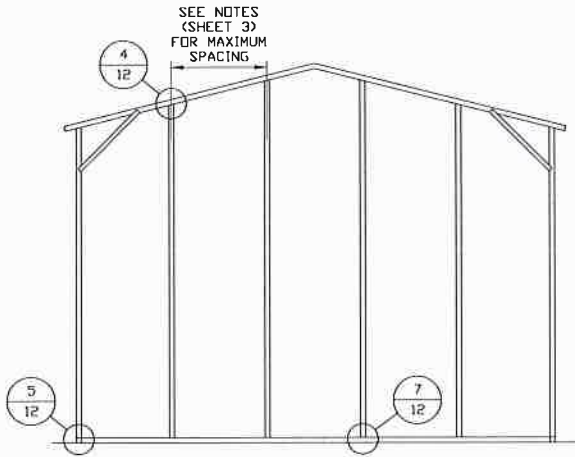

**TYPICAL BOX EAVE RAFTER
END WALL FRAMING SECTION**

SCALE: NTS

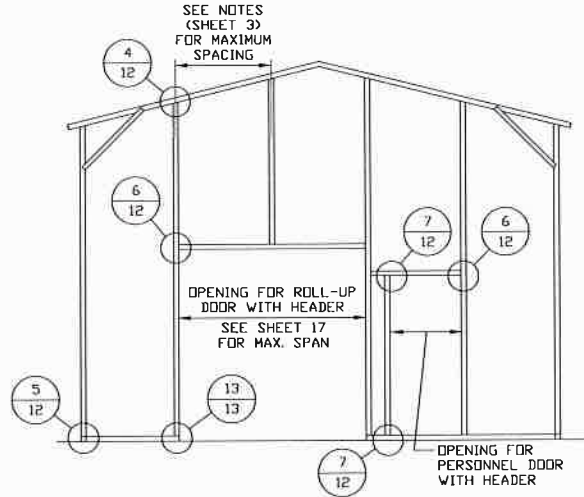

**TYPICAL BOX EAVE RAFTER END
WALL OPENINGS FRAMING SECTION**

SCALE: NTS

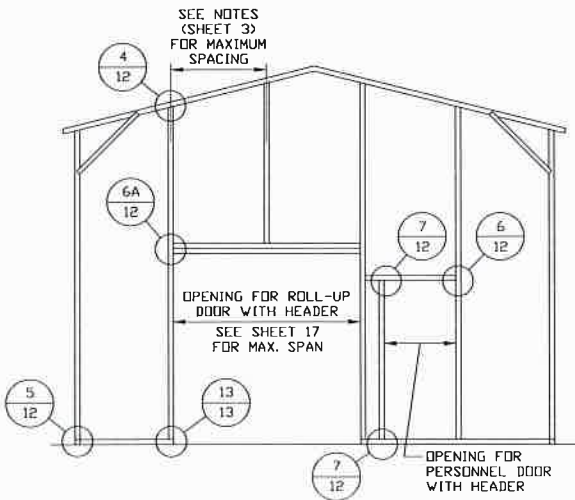

**TYPICAL BOX EAVE RAFTER END
WALL OPENINGS FRAMING SECTION**

SCALE: NTS

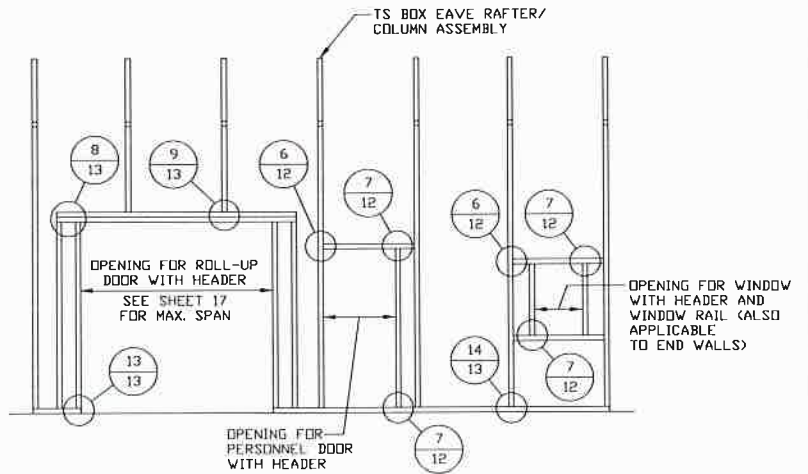

**TYPICAL BOX EAVE RAFTER
SIDE WALL OPENINGS FRAMING SECTION**

SCALE: NTS

**MOORE AND ASSOCIATES
ENGINEERING AND CONSULTING, INC.**

THIS DOCUMENT IS THE PROPERTY OF MOORE AND ASSOCIATES ENGINEERING AND CONSULTING. THE UNAUTHORIZED REPRODUCTION, COPYING, OR OTHERWISE USE OF THIS DOCUMENT IS STRICTLY PROHIBITED AND ANY INFRINGEMENT THEREUPON MAY BE SUBJECT TO LEGAL ACTION.

DRAWN BY: LT

CHECKED BY: PH

PROJECT MGR: WSM

CLIENT: JR BUILDINGS

JR BUILDINGS & GARAGES
316 NELSON STREET
PILOT MOUNTAIN, NC 27041
30'-0" x 16'-0" ENCLOSED STRUCTURE

DATE: 9-2-20

SHT. 10

SCALE: NTS

DWG. NO: SK-3

**JOB NO: 18184S/
18348S/19129S/20229S**

REV: 4

BOW EAVE RAFTER END WALL AND SIDE WALL OPENINGS

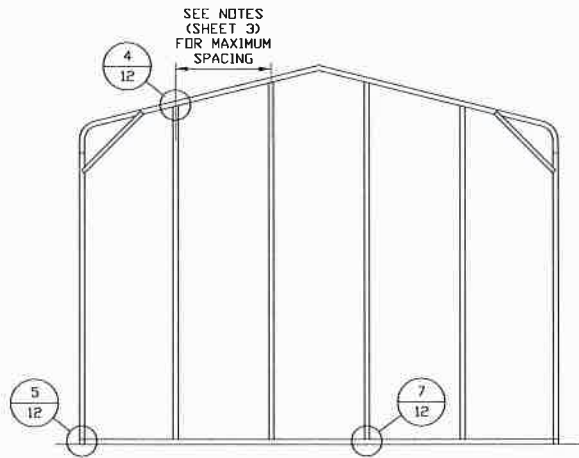

**TYPICAL BOW EAVE RAFTER
END WALL FRAMING SECTION**

SCALE: NTS

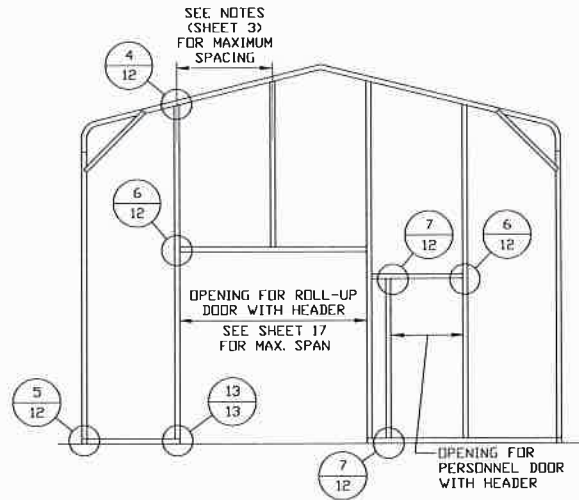

**TYPICAL BOW EAVE RAFTER END
WALL OPENINGS FRAMING SECTION**

SCALE: NTS

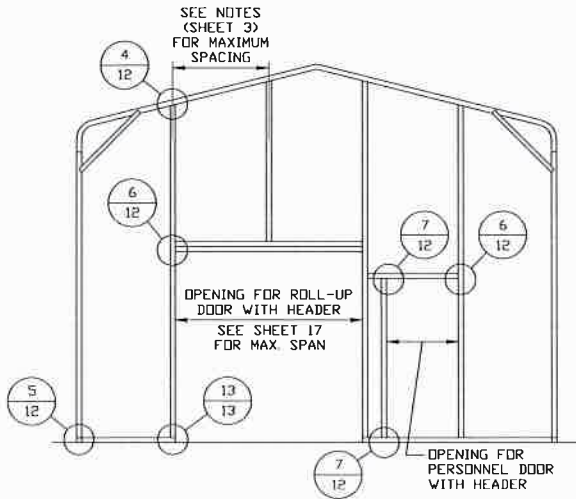

**TYPICAL BOW EAVE RAFTER END
WALL OPENINGS FRAMING SECTION**

SCALE: NTS

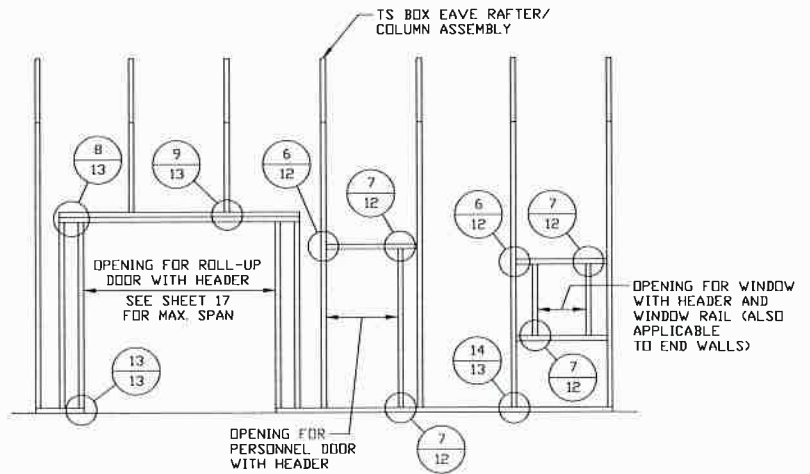

**TYPICAL BOW EAVE RAFTER
SIDE WALL OPENINGS FRAMING SECTION**

SCALE: NTS

**MOORE AND ASSOCIATES
ENGINEERING AND CONSULTING, INC.**

THIS DOCUMENT IS THE PROPERTY OF MOORE AND ASSOCIATES ENGINEERING AND CONSULTING. THE UNAUTHORIZED REPRODUCTION, COPYING, OR OTHERWISE USE OF THIS DOCUMENT IS STRICTLY PROHIBITED AND ANY INFRINGEMENT THEREUPON MAY BE SUBJECT TO LEGAL ACTION.

DRAWN BY: LT

CHECKED BY: PH

PROJECT MGR: WSM

CLIENT: JR BUILDINGS

JR BUILDINGS & GARAGES
316 NELSON STREET
PILOT MOUNTAIN, NC 27041
30'-0" x 16'-0" ENCLOSED STRUCTURE

DATE: 9-2-20

SHT. 11

SCALE: NTS

DWG. NO: SK-3

**JOB NO: 18184S/
18348S/19129S/20229S**

REV: 4

CONNECTION DETAILS

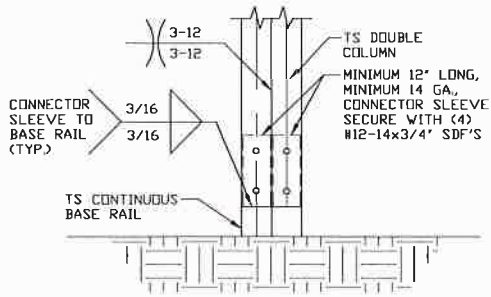

3 POST/BASE RAIL CONNECTION DETAIL
SCALE: NTS

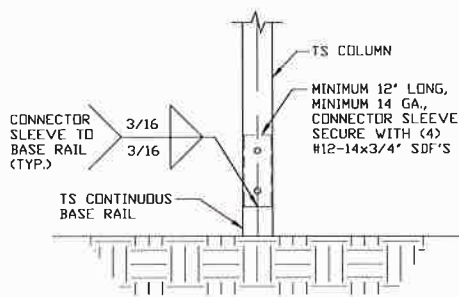

3A POST/BASE RAIL CONNECTION DETAIL
SCALE: NTS

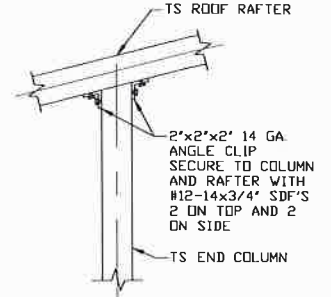

4 END COLUMN/RAFTER CONNECTION DETAIL
SCALE: NTS

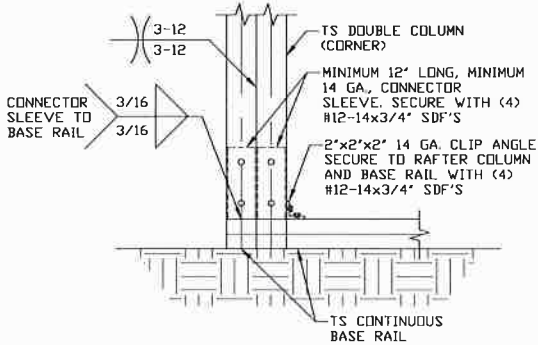

5 END COLUMN/BASE RAIL CONNECTION DETAIL
SCALE: NTS

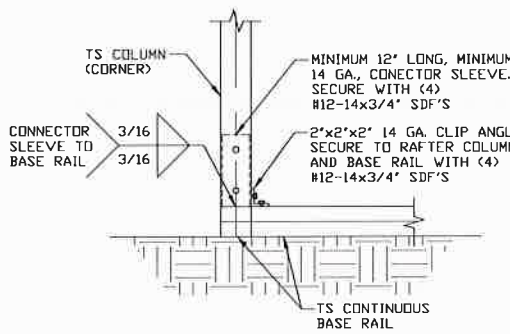

5A END COLUMN/BASE RAIL CONNECTION DETAIL
SCALE: NTS

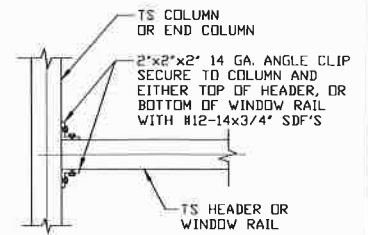

6 COLUMN OR WINDOW RAIL/WALL GIRT TO POST CONNECTION DETAIL
SCALE: NTS

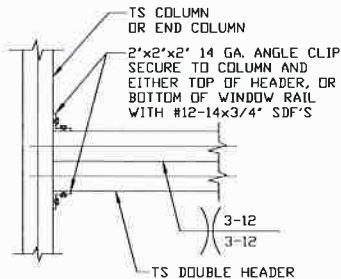

6A COLUMN OR WINDOW RAIL TO POST CONNECTION DETAIL
SCALE: NTS

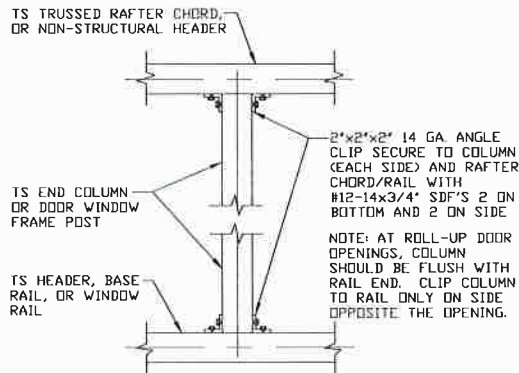

7 COLUMN TO HEADER, BASE RAIL, OR WINDOW RAIL CONNECTION DETAIL
SCALE: NTS

NOTE: AT ROLL-UP DOOR OPENINGS, COLUMN SHOULD BE FLUSH WITH RAIL END. CLIP COLUMN TO RAIL ONLY ON SIDE OPPOSITE THE OPENING.

**MOORE AND ASSOCIATES
ENGINEERING AND CONSULTING, INC.**

DRAWN BY: LT
CHECKED BY: PH
PROJECT MGR: WSM
CLIENT: JR BUILDINGS

JR BUILDINGS & GARAGES
316 NELSON STREET
PILOT MOUNTAIN, NC 27041
30'-0" x 16'-0" ENCLOSED STRUCTURE

DATE: 9-2-20
SCALE: NTS
SHT. 12
DWG. NO: SK-3

JOB NO: 18184S/
18348S/19129S/20229S
REV: 4

THIS DOCUMENT IS THE PROPERTY OF MOORE AND ASSOCIATES ENGINEERING AND CONSULTING. THE UNAUTHORIZED REPRODUCTION, COPYING, OR OTHERWISE USE OF THIS DOCUMENT IS STRICTLY PROHIBITED AND ANY INFRINGEMENT THEREUPON MAY BE SUBJECT TO LEGAL ACTION.

CONNECTION DETAILS

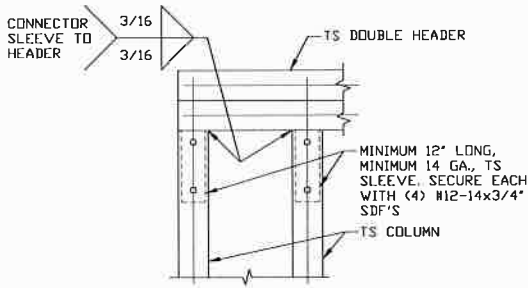

8 DOUBLE HEADER/COLUMN CONNECTION DETAIL
SCALE: NTS

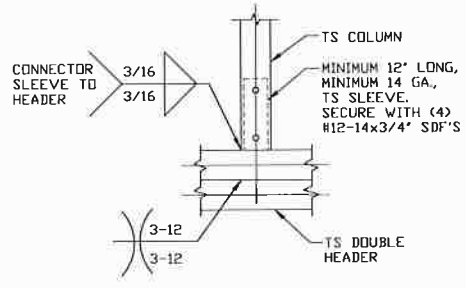

9 COLUMN/DOUBLE HEADER CONNECTION DETAIL
SCALE: NTS

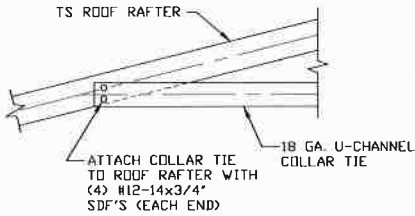

10 COLLAR TIE CONNECTION DETAIL
SCALE: NTS

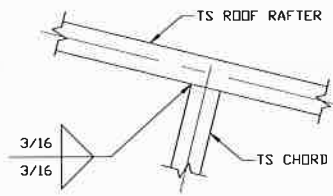

11 RAFTER TO CHORD CONNECTION DETAIL
SCALE: NTS

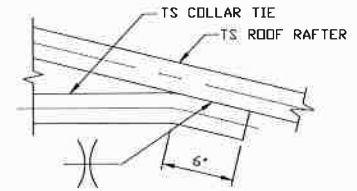

12 COLLAR TIE CONNECTION DETAIL
SCALE: NTS

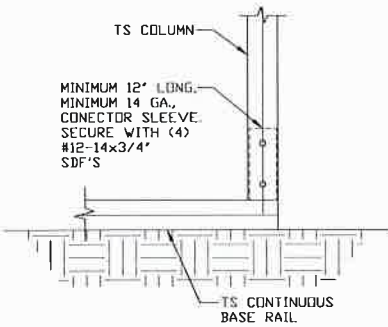

13 COLUMN/BASE RAIL CONNECTION DETAIL
SCALE: NTS

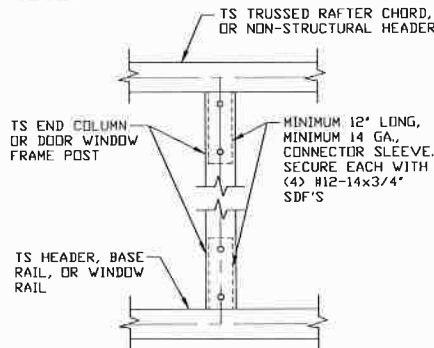

14 COLUMN TO HEADER OR BASE RAIL CONNECTION DETAIL
SCALE: NTS

**MOORE AND ASSOCIATES
ENGINEERING AND CONSULTING, INC.**

DRAWN BY: LT

CHECKED BY: PH

PROJECT MGR: WSM

CLIENT: JR BUILDINGS

**JR BUILDINGS & GARAGES
316 NELSON STREET
PILOT MOUNTAIN, NC 27041
30'-0" x 16'-0" ENCLOSED STRUCTURE**

DATE: 9-2-20

SHT. 13

SCALE: NTS

DWG. NO: SK-3

**JOB NO: 18184S/
18348S/19129S/20229S**

REV: 4

THIS DOCUMENT IS THE PROPERTY OF MOORE AND ASSOCIATES ENGINEERING AND CONSULTING. THE UNAUTHORIZED REPRODUCTION, COPYING, OR OTHERWISE USE OF THIS DOCUMENT IS STRICTLY PROHIBITED AND ANY INFRINGEMENT THEREUPON MAY BE SUBJECT TO LEGAL ACTION.

BOX EAVE RAFTER LEAN-TO OPTIONS

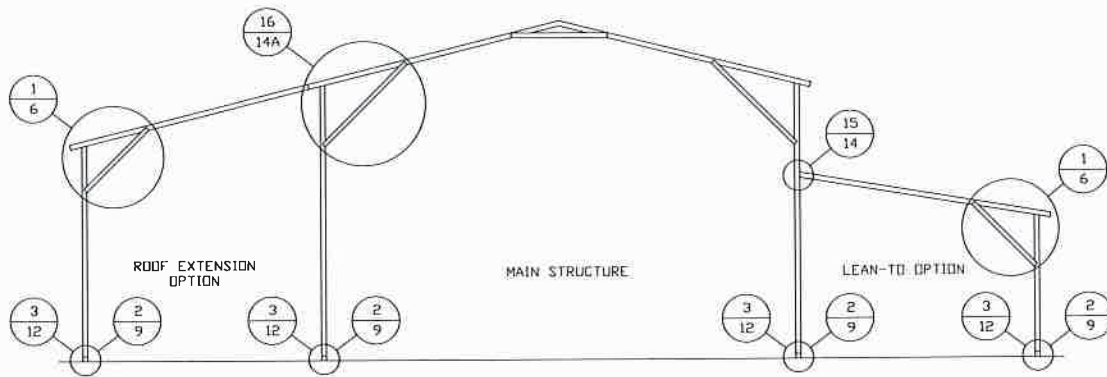

TYPICAL BOX EAVE RAFTER LEAN-TO OPTIONS FRAMING SECTION (BOTH OPTIONS SHOWN)

SCALE: NTS

MAXIMUM WIDTH OF ROOF EXTENSION AND LEAN-TO OPTION IS 12'-0".

FOR SHARED COLUMN HEIGHTS REFERENCE RAFTER COLUMN CONNECTION DETAILS FOR APPROPRIATE COLUMN HEIGHT AND TUBING SPECIFICATIONS.

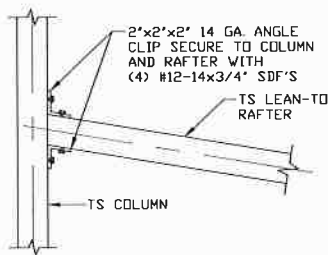

**LEAN-TO RAFTER TO
RAFTER POST
CONNECTION DETAIL
FOR WIDTHS ≤ 12'-0"**

15

SCALE: NTS

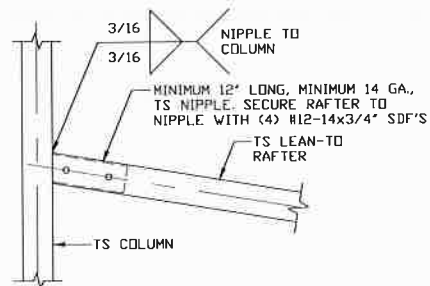

**OPTIONAL LEAN-TO
RAFTER TO RAFTER
POST CONNECTION DETAIL
FOR WIDTHS ≤ 12'-0"**

15A

SCALE: NTS

**MOORE AND ASSOCIATES
ENGINEERING AND CONSULTING, INC.**

DRAWN BY: LT

CHECKED BY: PH

PROJECT MGR: WSM

CLIENT: JR BUILDINGS

JR BUILDINGS & GARAGES
316 NELSON STREET
PILOT MOUNTAIN, NC 27041
30'-0" x 16'-0" ENCLOSED STRUCTURE

DATE: 9-2-20

SHT. 14

SCALE: NTS

DWG. NO: SK-3

**JOB NO: 18184S/
18348S/19129S/20229S**

REV: 4

THIS DOCUMENT IS THE PROPERTY OF MOORE AND ASSOCIATES ENGINEERING AND CONSULTING. THE UNAUTHORIZED REPRODUCTION, COPYING, OR OTHERWISE USE OF THIS DOCUMENT IS STRICTLY PROHIBITED AND ANY INFRINGEMENT THEREUPON MAY BE SUBJECT TO LEGAL ACTION.

BOX EAVE RAFTER LEAN-TO OPTIONS FOR RAFTER SPANS $\leq 12'-0''$

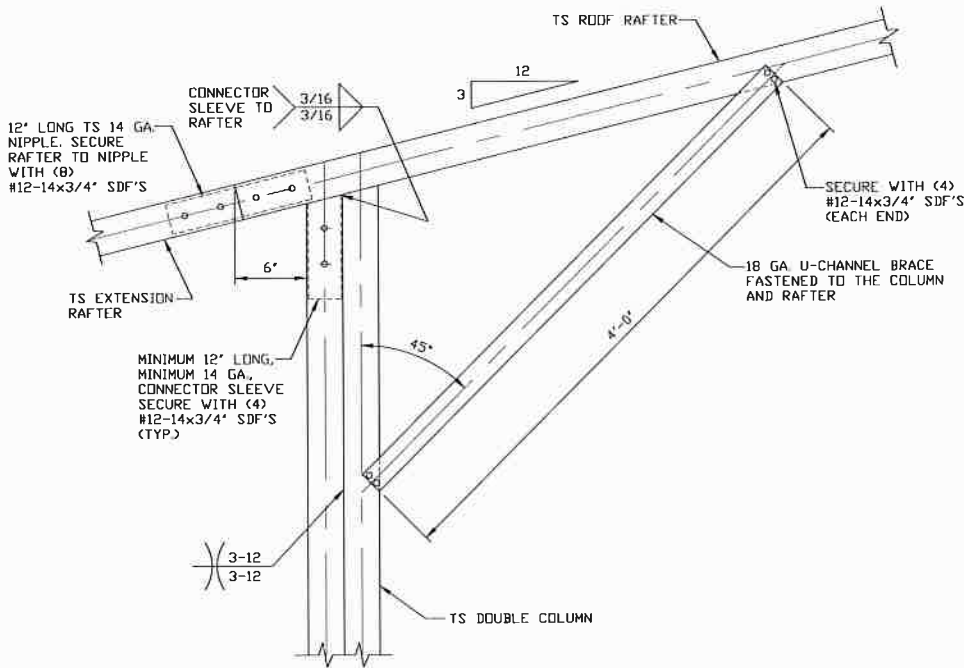

16 SIDE EXTENSION RAFTER/
COLUMN DETAIL FOR
HEIGHTS 12'-0" < TO \leq 16'-0"
SCALE: NTS

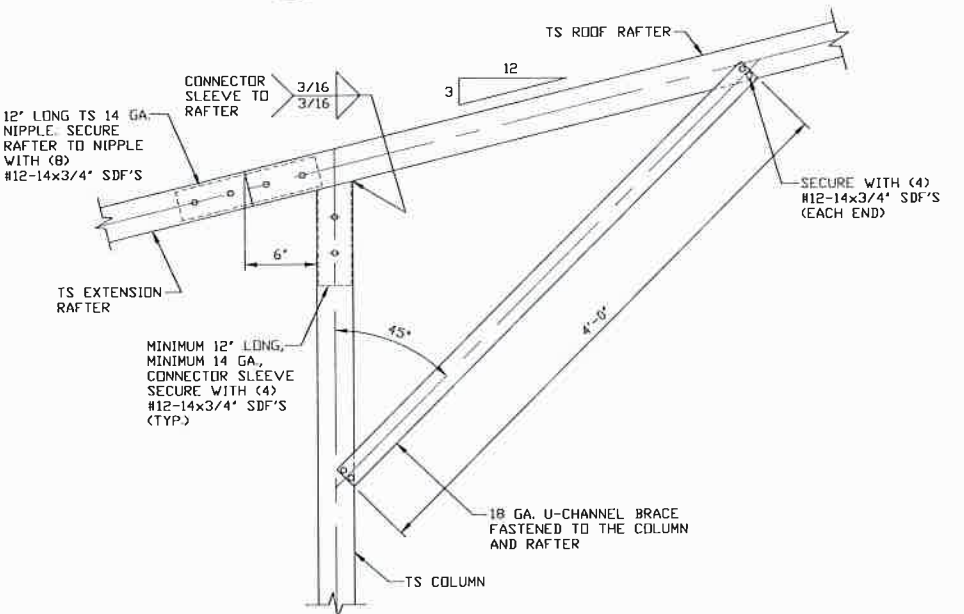

16A SIDE EXTENSION RAFTER/
COLUMN DETAIL FOR
HEIGHTS \leq 12'-0"
SCALE: NTS

**MOORE AND ASSOCIATES
ENGINEERING AND CONSULTING, INC.**

DRAWN BY: LT	JR BUILDINGS & GARAGES 316 NELSON STREET PILOT MOUNTAIN, NC 27041		
CHECKED BY: PH	30'-0" x 16'-0" ENCLOSED STRUCTURE		
PROJECT MGR: WSM	DATE: 9-2-20	SCALE: NTS	JOB NO: 18184S/ 18348S/19129S/20229S
CLIENT: JR BUILDINGS	SHT. 14A	DWG. NO: SK-3	REV: 4

THIS DOCUMENT IS THE PROPERTY OF MOORE AND ASSOCIATES ENGINEERING AND CONSULTING. THE UNAUTHORIZED REPRODUCTION, COPYING, OR OTHERWISE USE OF THIS DOCUMENT IS STRICTLY PROHIBITED AND ANY INFRINGEMENT THEREUPON MAY BE SUBJECT TO LEGAL ACTION.

BOW EAVE RAFTER LEAN-TO OPTIONS

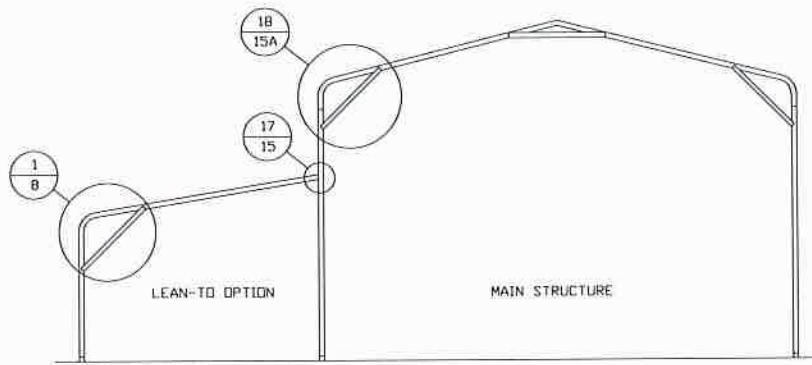

TYPICAL BOW EAVE RAFTER LEAN-TO OPTIONS FRAMING SECTION

SCALE: NTS

MAXIMUM WIDTH OF LEAN-TO OPTION IS 12'-0".

FOR SHARED COLUMN HEIGHTS REFERENCE RAFTER COLUMN CONNECTION DETAILS FOR APPROPRIATE COLUMN HEIGHT AND TUBING SPECIFICATIONS.

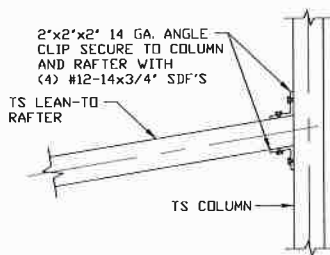

**LEAN-TO RAFTER TO
RAFTER POST
CONNECTION DETAIL
FOR WIDTHS \leq 12'-0"**

SCALE: NTS

17

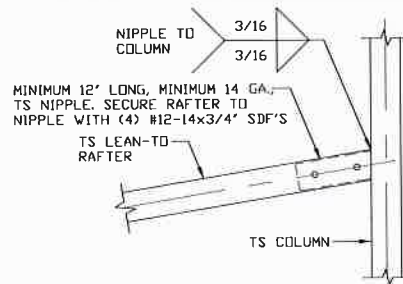

**OPTIONAL LEAN-TO
RAFTER TO RAFTER
POST CONNECTION DETAIL
FOR WIDTHS \leq 12'-0"**

SCALE: NTS

17A

**MOORE AND ASSOCIATES
ENGINEERING AND CONSULTING, INC.**

DRAWN BY: LT

CHECKED BY: PH

PROJECT MGR: WSM

CLIENT: JR BUILDINGS

JR BUILDINGS & GARAGES
316 NELSON STREET
PILOT MOUNTAIN, NC 27041
30'-0" x 16'-0" ENCLOSED STRUCTURE

DATE: 9-2-20

SHT. 15

SCALE: NTS

DWG. NO: SK-3

JOB NO: 18184S/
18348S/19129S/20229S

REV: 4

THIS DOCUMENT IS THE PROPERTY OF MOORE AND ASSOCIATES ENGINEERING AND CONSULTING. THE UNAUTHORIZED REPRODUCTION, COPYING, OR OTHERWISE USE OF THIS DOCUMENT IS STRICTLY PROHIBITED AND ANY INFRINGEMENT THEREUPON MAY BE SUBJECT TO LEGAL ACTION.

BOW EAVE RAFTER LEAN-TO OPTIONS FOR RAFTER SPANS $\leq 12'-0"$

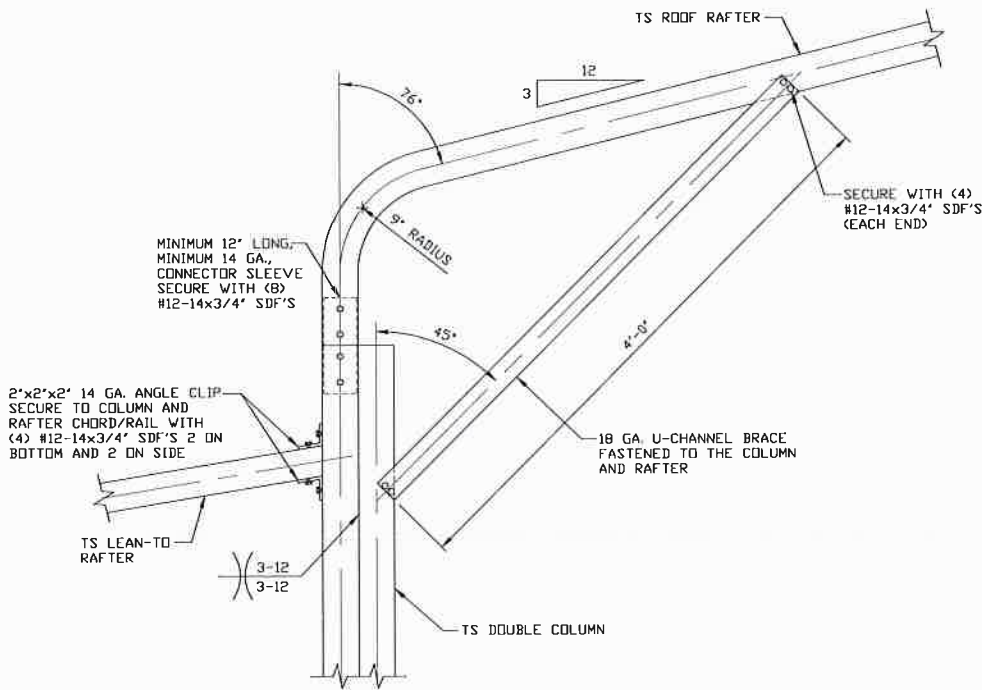

18

**SIDE EXTENSION RAFTER/
COLUMN DETAIL FOR
HEIGHTS 12'-0" < TO \leq 16'-0"**
SCALE: NTS

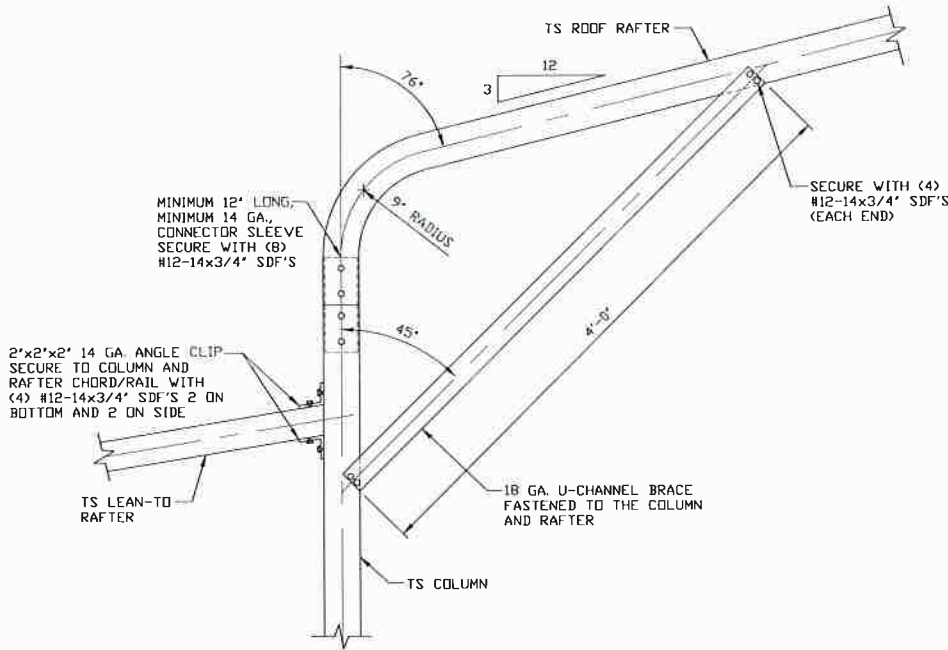

18A

**SIDE EXTENSION RAFTER/
COLUMN DETAIL FOR
HEIGHTS \leq 12'-0"**
SCALE: NTS

**MOORE AND ASSOCIATES
ENGINEERING AND CONSULTING, INC.**

DRAWN BY: LT

CHECKED BY: PH

PROJECT MGR: WSM

CLIENT: JR BUILDINGS

JR BUILDINGS & GARAGES
316 NELSON STREET
PILOT MOUNTAIN, NC 27041
30'-0" x 16'-0" ENCLOSED STRUCTURE

DATE: 9-2-20

SHT. 15A

SCALE: NTS

DWG. NO: SK-3

**JOB NO: 18184S/
18348S/19129S/20229S**

REV: 4

THIS DOCUMENT IS THE PROPERTY OF MOORE AND ASSOCIATES ENGINEERING AND CONSULTING. THE UNAUTHORIZED REPRODUCTION, COPYING, OR OTHERWISE USE OF THIS DOCUMENT IS STRICTLY PROHIBITED AND ANY INFRINGEMENT THEREUPON MAY BE SUBJECT TO LEGAL ACTION.

BOX EAVE RAFTER VERTICAL ROOF/SIDING OPTION

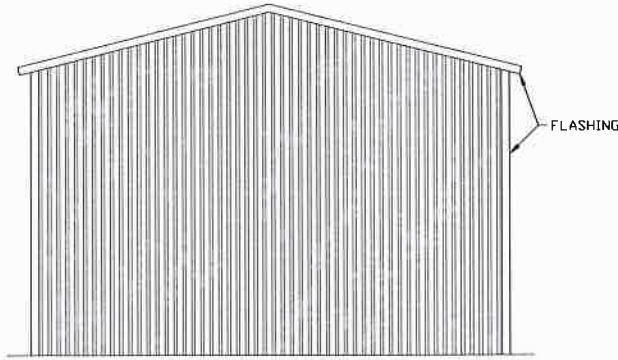

**TYPICAL END ELEVATION
VERTICAL ROOF/SIDING**
SCALE: NTS

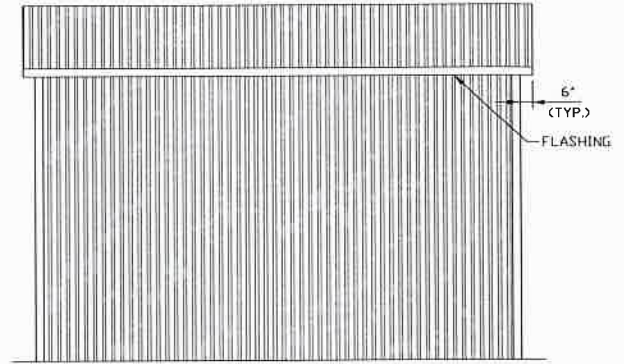

**TYPICAL SIDE ELEVATION
VERTICAL ROOF/SIDING**
SCALE: NTS

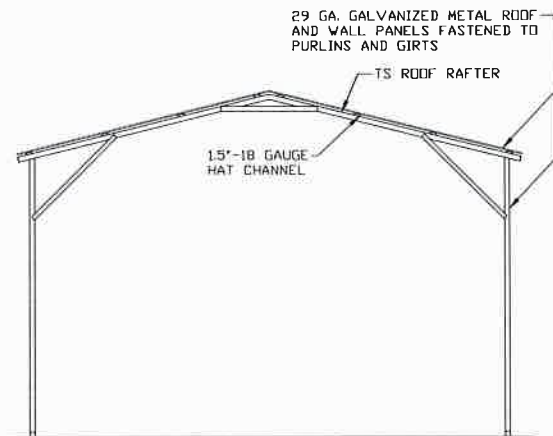

**TYPICAL SECTION VERTICAL
ROOF/SIDING OPTION**
SCALE: NTS

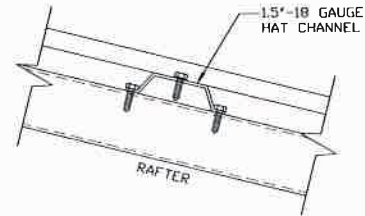

PANEL ATTACHMENT
(ALTERNATE FOR VERTICAL ROOF PANELS)
SCALE: NTS

**MOORE AND ASSOCIATES
ENGINEERING AND CONSULTING, INC.**

DRAWN BY: LT

CHECKED BY: PH

PROJECT MGR: WSM

CLIENT: JR BUILDINGS

JR BUILDINGS & GARAGES
316 NELSON STREET
PILOT MOUNTAIN, NC 27041
30'-0" x 16'-0" ENCLOSED STRUCTURE

DATE: 9-2-20

SHT. 16

SCALE: NTS

DWG. NO: SK-3

**JOB NO: 18184S/
18348S/19129S/20229S**

REV: 4

THIS DOCUMENT IS THE PROPERTY OF MOORE AND ASSOCIATES ENGINEERING AND CONSULTING. THE UNAUTHORIZED REPRODUCTION, COPYING, OR OTHERWISE USE OF THIS DOCUMENT IS STRICTLY PROHIBITED AND ANY INFRINGEMENT THEREUPON MAY BE SUBJECT TO LEGAL ACTION.

BOX EAVE RAFTER VERTICAL ROOF/SIDING OPTION

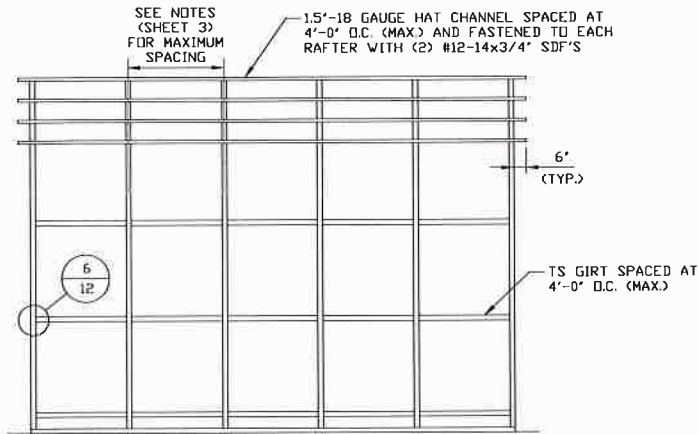

TYPICAL FRAMING SECTION VERTICAL ROOF/SIDING OPTION WITH TS GIRTS
SCALE: NTS

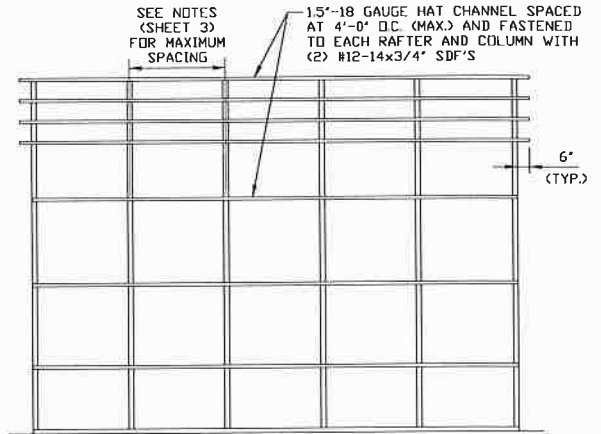

TYPICAL FRAMING SECTION VERTICAL ROOF/SIDING OPTION WITH HAT CHANNEL GIRTS
SCALE: NTS

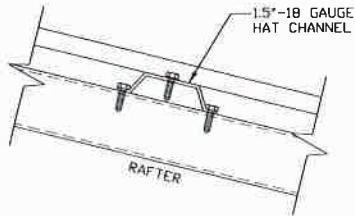

PANEL ATTACHMENT
(ALTERNATE FOR VERTICAL ROOF PANELS)
SCALE: NTS

**MOORE AND ASSOCIATES
ENGINEERING AND CONSULTING, INC.**

DRAWN BY: LT

CHECKED BY: PH

PROJECT MGR: WSM

CLIENT: JR BUILDINGS

**JR BUILDINGS & GARAGES
316 NELSON STREET
PILOT MOUNTAIN, NC 27041
30'-0" x 16'-0" ENCLOSED STRUCTURE**

DATE: 9-2-20

SHT. 16A

SCALE: NTS

DWG. NO: SK-3

**JOB NO: 18184S/
18348S/19129S/20229S**

REV: 4

THIS DOCUMENT IS THE PROPERTY OF MOORE AND ASSOCIATES ENGINEERING AND CONSULTING. THE UNAUTHORIZED REPRODUCTION, COPYING, OR OTHERWISE USE OF THIS DOCUMENT IS STRICTLY PROHIBITED AND ANY INFRINGEMENT THEREUPON MAY BE SUBJECT TO LEGAL ACTION.

SIDE WALL HEADER OPTIONS

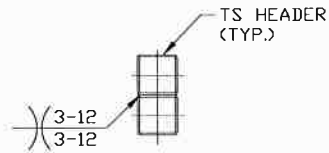

**HEADER DETAIL FOR
7'-0" < LENGTH ≤ 12'-0"**
SCALE: NTS

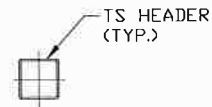

**HEADER DETAIL FOR
DOOR OPENINGS ≤ 7'-0"**
SCALE: NTS

END WALL HEADER OPTIONS

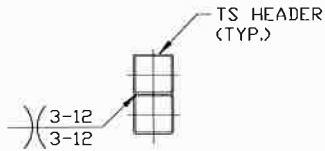

**HEADER DETAIL FOR
12'-0" < LENGTH ≤ 20'-0"**
SCALE: NTS

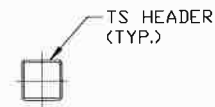

**HEADER DETAIL FOR
DOOR OPENINGS ≤ 12'-0"**
SCALE: NTS

**MOORE AND ASSOCIATES
ENGINEERING AND CONSULTING, INC.**

DRAWN BY: LT

CHECKED BY: PH

PROJECT MGR: VSM

CLIENT: JR BUILDINGS

JR BUILDINGS & GARAGES
316 NELSON STREET
PILOT MOUNTAIN, NC 27041
30'-0" x 16'-0" ENCLOSED STRUCTURE

DATE: 9-2-20

SHT. 17

SCALE: NTS

DWG. NO: SK-3

**JOB NO: 18184S/
18348S/19129S/20229S**

REV: 4

THIS DOCUMENT IS THE PROPERTY OF MOORE AND ASSOCIATES ENGINEERING AND CONSULTING. THE UNAUTHORIZED REPRODUCTION, COPYING, OR OTHERWISE USE OF THIS DOCUMENT IS STRICTLY PROHIBITED AND ANY INFRINGEMENT THEREUPON MAY BE SUBJECT TO LEGAL ACTION.