



PILOT MOUNTAIN, NORTH CAROLINA

**STRUCTURAL DESIGN  
ENCLOSED BUILDING**

**MAXIMUM 30'-0" WIDE X 16'-0" EAVE HEIGHT- BOX EAVE  
FRAME**

**2 July 2020**

**Revision 2**

**M&A Project No. 18315S/19179S/20176S**

**Prepared for:**

**NC Carports and Garages, LLC  
309 S. Depot Street  
Pilot Mountain, NC 27041**

**Prepared by:**

**Moore and Associates Engineering  
and Consulting, Inc.**

**1009 East Avenue  
North Augusta, SC 29841**

**401 S. Main St., Suite 200  
Mt. Airy, NC 27030**



**MOORE AND ASSOCIATES  
ENGINEERING AND CONSULTING**

			<p><b>Professional Certification.</b> I hereby certify that these documents were prepared or approved by me, and that I am a duly licensed professional engineer under the laws of the State of Maryland, License No. 49744, Expiration Date <u>8/6/22</u></p>

MOORE AND ASSOCIATES  
ENGINEERING AND CONSULTING, INC.

THIS DOCUMENT IS THE PROPERTY OF MOORE AND ASSOCIATES ENGINEERING AND CONSULTING. THE UNAUTHORIZED REPRODUCTION, COPYING, OR OTHERWISE USE OF THIS DOCUMENT IS STRICTLY PROHIBITED AND ANY INFRINGEMENT THEREUPON MAY BE SUBJECT TO LEGAL ACTION.

DRAWN BY: JG		NC CARPORTS AND GARAGES, LLC	
CHECKED BY: PH		309 S. DEPOT STREET	
PROJECT MGR: WSM		PILOT MOUNTAIN, NC 27041	
DATE: 7-2-20		30'-0" x 16'-0" ENCLOSED STRUCTURE	
CLIENT: NC CARPORTS	SHT. 1	SCALE: NTS	18315S/19179S/ JOB NO: 20176S
		DWG. NO: SK-3	REV: 2

# DRAWING INDEX

SHEET 1	PE SEAL COVER SHEET
SHEET 2	DRAWING INDEX
SHEET 3A	INSTALLATION NOTES AND SPECIFICATIONS
SHEET 3B	TYPICAL SIDE AND END ELEVATIONS
SHEET 3C	TYPICAL SIDE AND END ELEVATIONS
SHEET 4	TYPICAL RAFTER/COLUMN FRAME AND SIDE FRAMING SECTION (BOX EAVE STRUCTURE)
SHEET 4A	TYPICAL RAFTER/COLUMN FRAME AND SIDE FRAMING SECTION (BOX EAVE STRUCTURE)
SHEET 4B	TYPICAL RAFTER/COLUMN FRAME AND SIDE FRAMING SECTION (BOW EAVE STRUCTURE)
SHEET 4C	TYPICAL RAFTER/COLUMN FRAME AND SIDE FRAMING SECTION (BOW EAVE STRUCTURE)
SHEET 5	COLUMN CONNECTION DETAILS (BOX EAVE STRUCTURE)
SHEET 6	COLUMN CONNECTION DETAILS (BOW EAVE STRUCTURE)
SHEET 7	BASE RAIL ANCHORAGE OPTIONS
SHEET 7A	BASE RAIL ANCHORAGE OPTIONS
SHEET 8	TYPICAL END WALL AND SIDE WALL FRAMING SECTIONS
SHEET 8A	TYPICAL END WALL AND SIDE WALL FRAMING SECTIONS
SHEET 9	CONNECTION DETAILS
SHEET 10	CONNECTION DETAILS
SHEET 10A	CONNECTION DETAILS
SHEET 11	LEAN-TO OPTIONS
SHEET 11A	LEAN-TO OPTIONS
SHEET 11B	LEAN-TO OPTIONS
SHEET 12	VERTICAL ROOF/SIDING OPTION END AND SIDE ELEVATION AND SECTION
SHEET 12A	VERTICAL ROOF/SIDING OPTION END AND SIDE ELEVATION AND SECTION

**MOORE AND ASSOCIATES  
ENGINEERING AND CONSULTING, INC.**

**DRAWN BY: JG**

**CHECKED BY: PH**

**PROJECT MGR: WSM**

**CLIENT: NC CARPORTS**

NC CARPORTS AND GARAGES, LLC  
309 S. DEPOT STREET  
PILOT MOUNTAIN, NC 27041  
30'-0" x 16'-0" ENCLOSED STRUCTURE

**DATE: 7-2-20**

**SCALE: NTS**

**JOB NO: 18315S/19179S/  
20176S**

**SHT. 2**

**DWG. NO: SK-3**

**REV: 2**

THIS DOCUMENT IS THE PROPERTY OF MOORE AND ASSOCIATES ENGINEERING AND CONSULTING. THE UNAUTHORIZED REPRODUCTION, COPYING, OR OTHERWISE USE OF THIS DOCUMENT IS STRICTLY PROHIBITED AND ANY INFRINGEMENT THEREUPON MAY BE SUBJECT TO LEGAL ACTION.

## INSTALLATION NOTES AND SPECIFICATIONS

1. DESIGN IS FOR MAXIMUM 30'-0" WIDE x 16'-0" EAVE HEIGHT ENCLOSED STRUCTURES.
2. DESIGN WAS DONE IN ACCORDANCE WITH THE 2018 NORTH CAROLINA BUILDING CODE, 2009 INTERNATIONAL BUILDING CODE (IBC), 2012 IBC, 2015 IBC AND 2018 IBC.
3. DESIGN LOADS ARE AS FOLLOWS:
  - A) DEAD LOAD = 1.5 PSF
  - B) LIVE LOAD = 12 PSF
  - C) GROUND SNOW LOAD = 35 PSF
  - = 30 PSF ( $W \leq 24'-0"$  WITH U-CHANNEL COLLAR TIE)
- NOTE: UNBALANCED SNOW LOADS DUE TO DRIFTING HAVE NOT BEEN EVALUATED.
4. 3-SECOND GUST ULTIMATE WIND SPEED ( $V_{ULT}$ ) 105 TO 145 MPH (NOMINAL WIND SPEED 82 TO 112 MPH).
5. MAXIMUM RAFTER/COLUMN AND END COLUMN SPACING = 50 FEET (UNLESS NOTED OTHERWISE).
6. SIDEWALL COLUMNS AND ENDWALL COLUMNS ARE SIMILAR IN SIZE, UNLESS NOTED OTHERWISE.
7. RISK CATEGORY I.
8. WIND EXPOSURE CATEGORY B.
9. SPECIFICATIONS APPLICABLE TO 29 GAUGE METAL PANELS FASTENED DIRECTLY TO 2 1/2" x 2 1/2" - 14 GAUGE TUBE STEEL (TS) FRAMING MEMBERS (UNLESS NOTED OTHERWISE).
10. AVERAGE FASTENER SPACING ON-CENTERS ALONG RAFTERS OR HAT CHANNELS, AND COLUMNS (INTERIOR OR END) = 9 INCHES.
11. FASTENERS CONSIST OF #12-14x3/4" SELF-DRILLING FASTENER (SDF), USE CONTROL SEAL WASHER WITH EXTERIOR FASTENERS. SPECIFICATIONS APPLICABLE ONLY FOR MEAN ROOF HEIGHT OF 16 FEET OR LESS, AND ROOF SLOPES OF 14" (3:12 PITCH) OR LESS SPACING REQUIREMENTS FOR OTHER ROOF HEIGHTS AND/OR SLOPES MAY VARY.
12. ANCHORS SHALL BE INSTALLED THROUGH BASE RAIL WITHIN 6" OF EACH COLUMN.
13. STANDARD GROUND ANCHORS (SOIL NAILS) CONSIST OF #4 REBAR W/WELDED NUT 30" LONG. SOIL NAILS MAY BE USED FOR WIND SPEEDS  $\leq 145$  MPH AND IN SUITABLE SOIL CONDITIONS. OPTIONAL ANCHORAGE MAY BE USED IN SUITABLE SOILS AND MUST BE USED FOR WIND SPEEDS  $> 145$  MPH AND/OR IN SUITABLE SOILS AS NOTED.
14. WIND FORCES GOVERN OVER SEISMIC FORCES. SEISMIC PARAMETERS ANALYZED ARE:
  - SOIL SITE CLASS = D
  - RISK CATEGORY I
  - R = 3.25                       $I_E = 1.0$
  - $S_{DS} = 2.039$                  $V = C_s W$
  - $S_{D1} = 1.258$

<b>MOORE AND ASSOCIATES ENGINEERING AND CONSULTING, INC.</b>	DRAWN BY: JG	NC CARPORTS AND GARAGES, LLC 309 S. DEPOT STREET PILOT MOUNTAIN, NC 27041 30'-0"x16'-0" ENCLOSED STRUCTURE		
	CHECKED BY: PH			
THIS DOCUMENT IS THE PROPERTY OF MOORE AND ASSOCIATES ENGINEERING AND CONSULTING. THE UNAUTHORIZED REPRODUCTION, COPYING, OR OTHERWISE USE OF THIS DOCUMENT IS STRICTLY PROHIBITED AND ANY INFRINGEMENT THEREUPON MAY BE SUBJECT TO LEGAL ACTION.	PROJECT MGR: WSH	DATE: 7-2-20	SCALE: NTS	JOB NO: 20176S 18315S/19179S/
	CLIENT: NC CARPORTS	SHT. 3A	DWG. NO: SK-3	REV: 2

## BOX EAVE FRAME RAFTER STRUCTURE

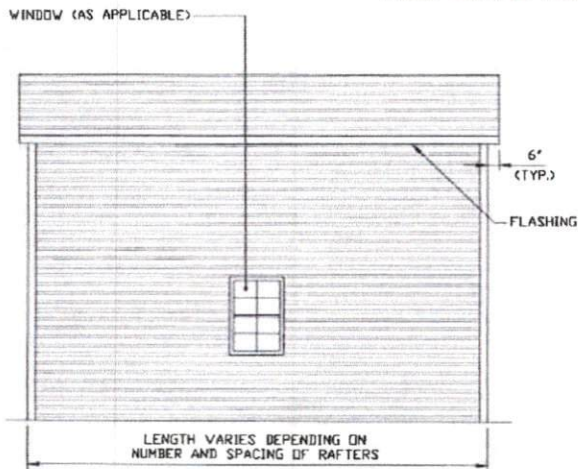

**TYPICAL SIDE ELEVATION**  
SCALE: NTS

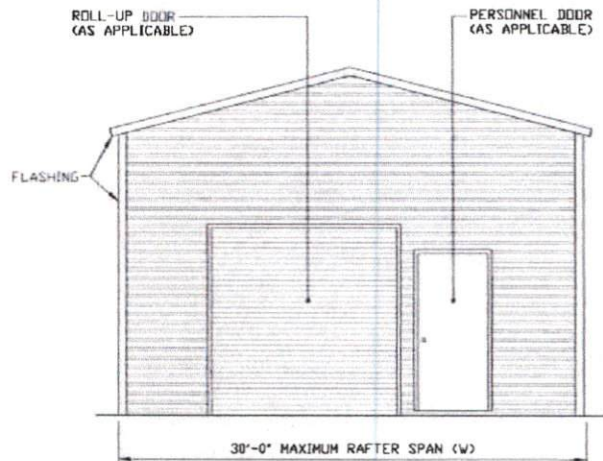

**TYPICAL END ELEVATION**  
SCALE: NTS

**MOORE AND ASSOCIATES  
ENGINEERING AND CONSULTING, INC.**

**DRAWN BY:** JG

**CHECKED BY:** PH

**PROJECT MGR:** WSH

**CLIENT:** NC CARPORTS

NC CARPORTS AND GARAGES, LLC  
309 S. DEPOT STREET  
PILOT MOUNTAIN, NC 27041  
30'-0" x 16'-0" ENCLOSED STRUCTURE

**DATE:** 7-2-20

**SHT.** 3B

**SCALE:** NTS

**DWG. NO:** SK-3

**18315S/19179S/  
JOB NO:** 20176S

**REV:** 2

THIS DOCUMENT IS THE PROPERTY OF MOORE AND ASSOCIATES ENGINEERING AND CONSULTING. THE UNAUTHORIZED REPRODUCTION, COPYING, OR OTHERWISE USE OF THIS DOCUMENT IS STRICTLY PROHIBITED AND ANY INFRINGEMENT THEREUPON MAY BE SUBJECT TO LEGAL ACTION.

### BOW EAVE FRAME RAFTER STRUCTURE

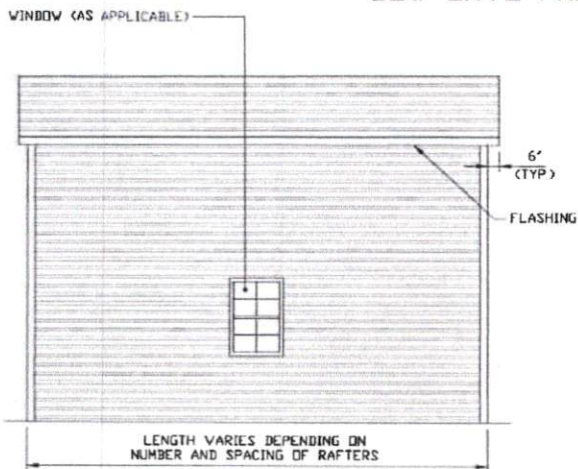

**TYPICAL SIDE ELEVATION**  
SCALE: NTS

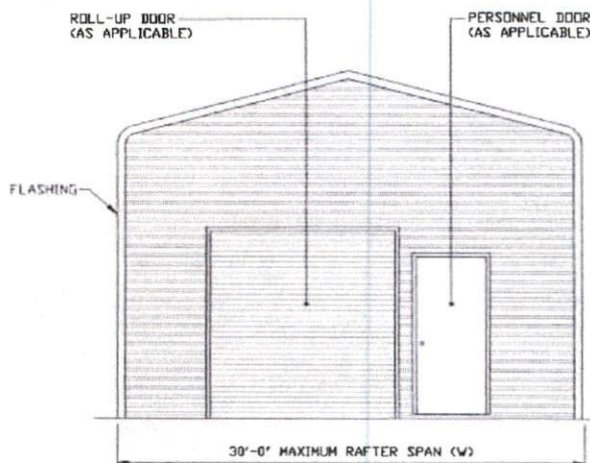

**TYPICAL END ELEVATION**  
SCALE: NTS

**MOORE AND ASSOCIATES  
ENGINEERING AND CONSULTING, INC.**

DRAWN BY: JG

CHECKED BY: PH

PROJECT MGR: WSM

CLIENT: NC CARPORTS

NC CARPORTS AND GARAGES, LLC  
309 S. DEPOT STREET  
PILOT MOUNTAIN, NC 27041  
30'-0" x 16'-0" ENCLOSED STRUCTURE

DATE: 7-2-20

SHT. 3C

SCALE: NTS

DWG. NO: SK-3

18315S/19179S/  
JOB NO: 20176S

REV: 2

THIS DOCUMENT IS THE PROPERTY OF MOORE AND ASSOCIATES ENGINEERING AND CONSULTING. THE UNAUTHORIZED REPRODUCTION, COPYING, OR OTHERWISE USE OF THIS DOCUMENT IS STRICTLY PROHIBITED AND ANY INFRINGEMENT THEREUPON MAY BE SUBJECT TO LEGAL ACTION.

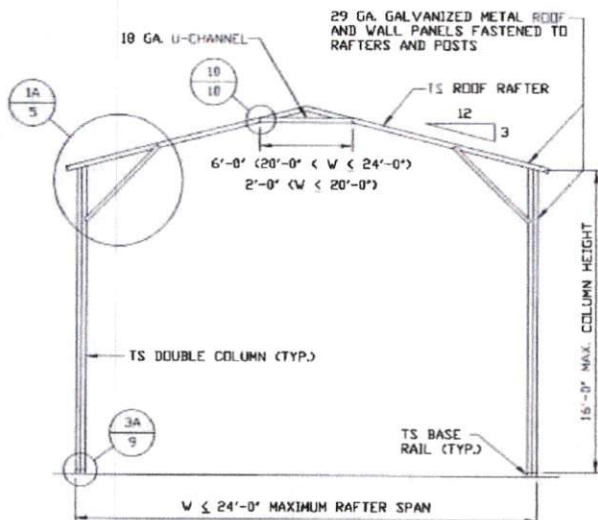

**TYPICAL RAFTER/COLUMN FRAME SECTION**  
 SCALE: NTS

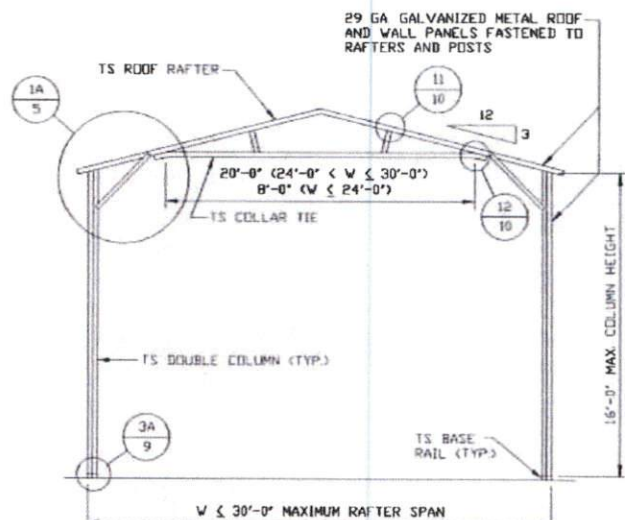

**TYPICAL RAFTER/COLUMN FRAME SECTION**  
 SCALE: NTS

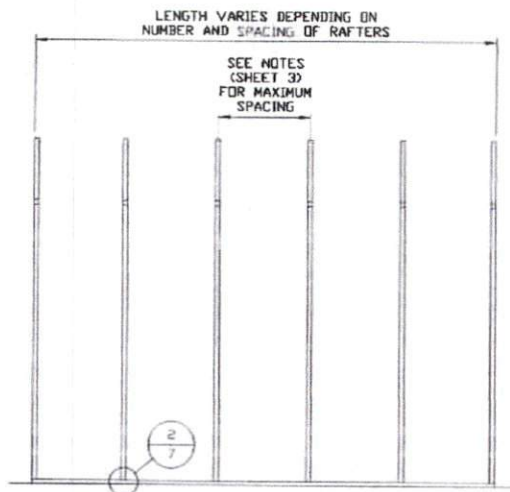

**TYPICAL RAFTER/COLUMN SIDE FRAMING SECTION**  
 SCALE: NTS

**MOORE AND ASSOCIATES  
 ENGINEERING AND CONSULTING, INC.**

DRAWN BY: JG

CHECKED BY: PH

PROJECT MGR: WSH

CLIENT: NC CARPORTS

NC CARPORTS AND GARAGES, LLC  
 309 S. DEPOT STREET  
 PILOT MOUNTAIN, NC 27041  
 30'-0" x 16'-0" ENCLOSED STRUCTURE

DATE: 7-2-20

SHT. 4

SCALE: NTS

DWG. NO: SK-3

18315S/19179S/  
 JOB NO: 20176S

REV: 2

THIS DOCUMENT IS THE PROPERTY OF MOORE AND ASSOCIATES ENGINEERING AND CONSULTING. THE UNAUTHORIZED REPRODUCTION, COPYING, OR OTHERWISE USE OF THIS DOCUMENT IS STRICTLY PROHIBITED AND ANY INFRINGEMENT THEREUPON MAY BE SUBJECT TO LEGAL ACTION.

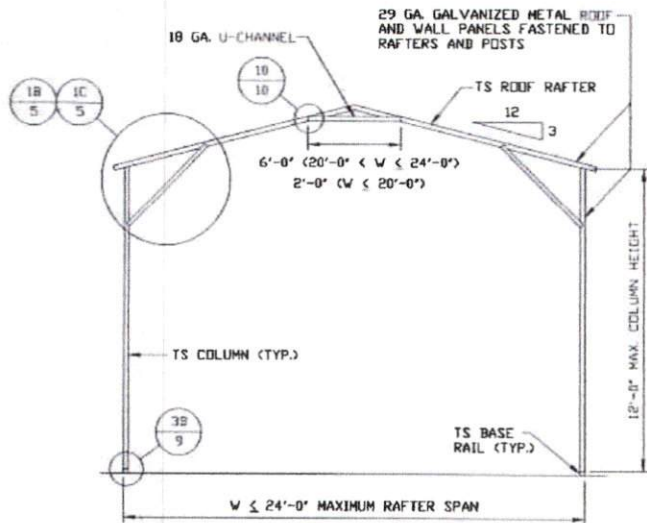

**TYPICAL RAFTER/COLUMN FRAME SECTION**  
SCALE: NTS

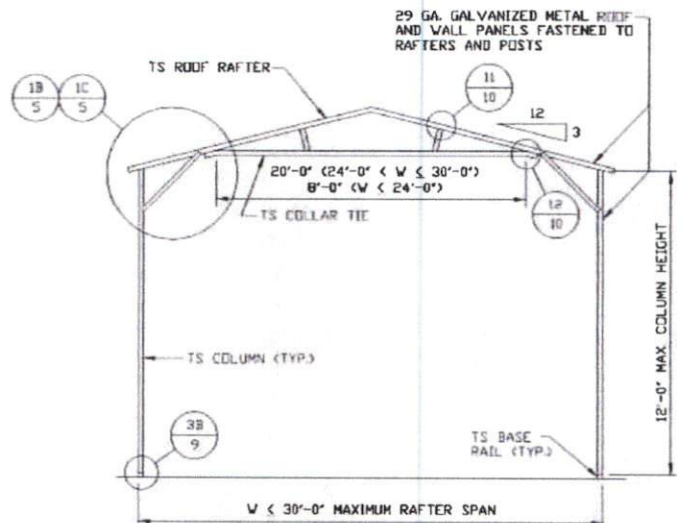

**TYPICAL RAFTER/COLUMN FRAME SECTION**  
SCALE: NTS

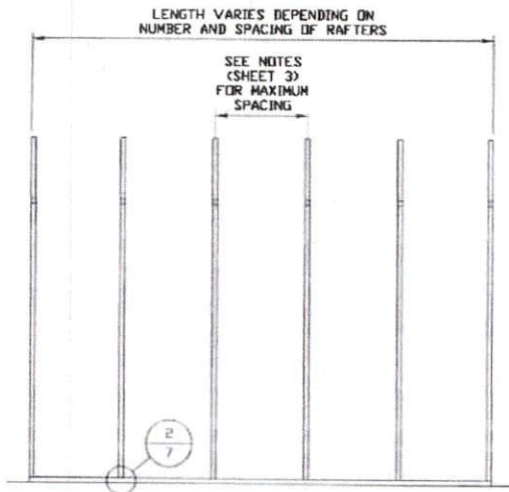

**TYPICAL RAFTER/COLUMN SIDE FRAMING SECTION**  
SCALE: NTS

**MOORE AND ASSOCIATES  
ENGINEERING AND CONSULTING, INC.**

DRAWN BY: JG

CHECKED BY: PH

PROJECT MGR: WSM

CLIENT: NC CARPORTS

NC CARPORTS AND GARAGES, LLC  
309 S. DEPOT STREET  
PILOT MOUNTAIN, NC 27041  
30'-0" x 16'-0" ENCLOSED STRUCTURE

DATE: 7-2-20

SHT. 4A

SCALE: NTS

DWG. NO: SK-3

18315S/19179S/  
JOB NO: 20176S

REV: 2

THIS DOCUMENT IS THE PROPERTY OF MOORE AND ASSOCIATES ENGINEERING AND CONSULTING. THE UNAUTHORIZED REPRODUCTION, COPYING, OR OTHERWISE USE OF THIS DOCUMENT IS STRICTLY PROHIBITED AND ANY INFRINGEMENT THEREUPON MAY BE SUBJECT TO LEGAL ACTION.



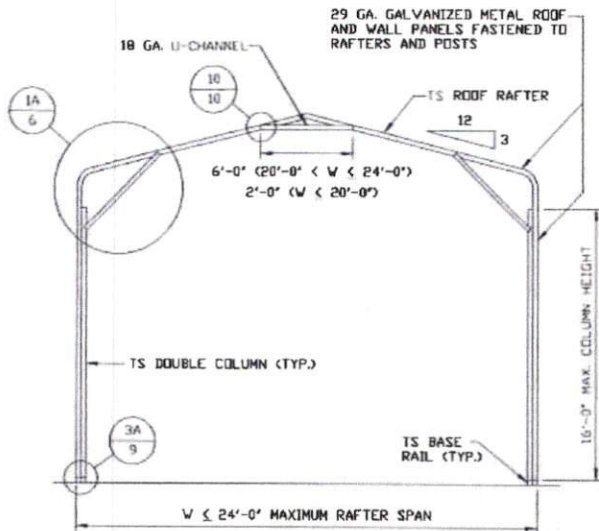

**TYPICAL RAFTER/COLUMN FRAME SECTION**  
SCALE: NTS

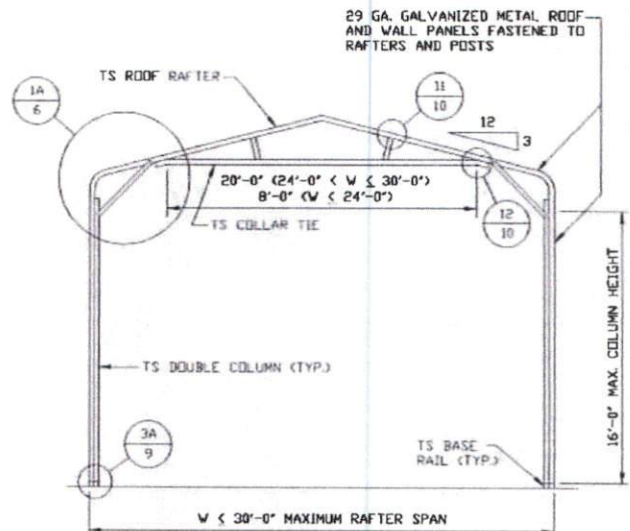

**TYPICAL RAFTER/COLUMN FRAME SECTION**  
SCALE: NTS

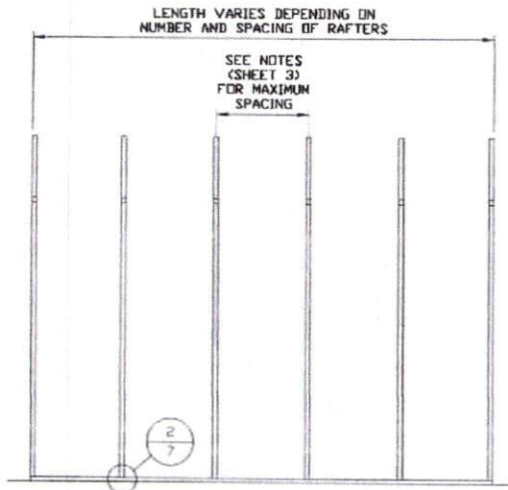

**TYPICAL RAFTER/COLUMN SIDE FRAMING SECTION**  
SCALE: NTS

**MOORE AND ASSOCIATES  
ENGINEERING AND CONSULTING, INC.**

DRAWN BY: JG

CHECKED BY: PH

PROJECT MGR: WSM

CLIENT: NC CARPORTS

NC CARPORTS AND GARAGES, LLC  
309 S. DEPOT STREET  
PILOT MOUNTAIN, NC 27041  
30'-0" x 16'-0" ENCLOSED STRUCTURE

DATE: 7-2-20

SHT. 4B

SCALE: NTS

DWG. NO: SK-3

183158/19179S/  
JOB NO: 20176S

REV: 2

THIS DOCUMENT IS THE PROPERTY OF MOORE AND ASSOCIATES ENGINEERING AND CONSULTING. THE UNAUTHORIZED REPRODUCTION, COPYING, OR OTHERWISE USE OF THIS DOCUMENT IS STRICTLY PROHIBITED AND ANY INFRINGEMENT THEREUPON MAY BE SUBJECT TO LEGAL ACTION.

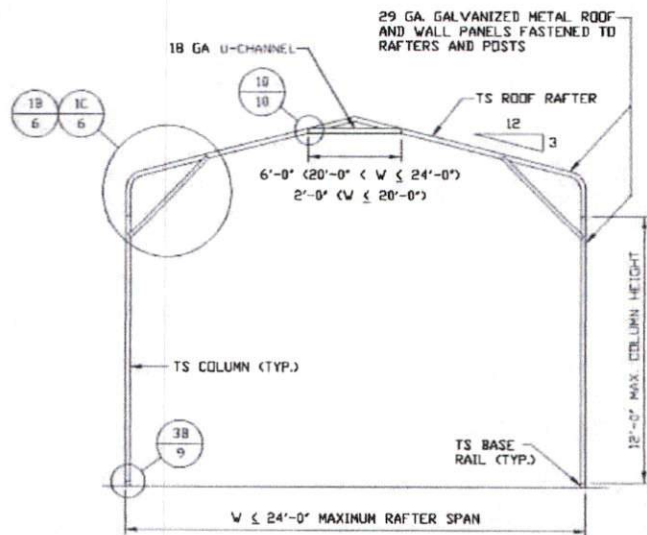

**TYPICAL RAFTER/COLUMN FRAME SECTION**  
SCALE: NTS

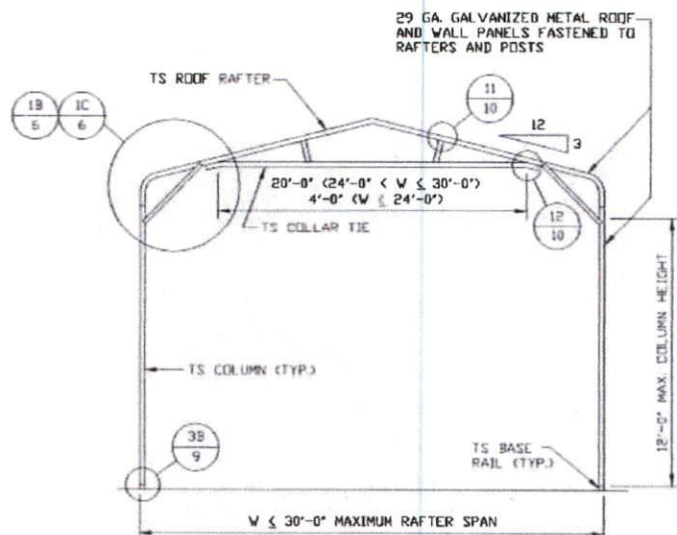

**TYPICAL RAFTER/COLUMN FRAME SECTION**  
SCALE: NTS

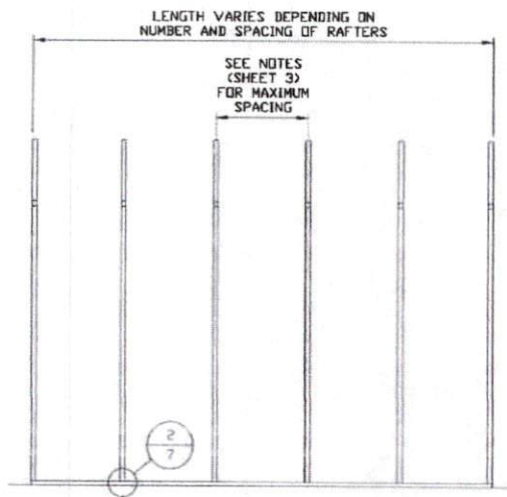

**TYPICAL RAFTER/COLUMN SIDE FRAMING SECTION**  
SCALE: NTS

**MOORE AND ASSOCIATES  
ENGINEERING AND CONSULTING, INC.**

DRAWN BY: JG

CHECKED BY: PH

PROJECT MGR: WSM

CLIENT: NC CARPORTS

NC CARPORTS AND GARAGES, LLC  
309 S. DEPOT STREET  
PILOT MOUNTAIN, NC 27041  
30'-0" x 16'-0" ENCLOSED STRUCTURE

DATE: 7-2-20

SHT. 4C

SCALE: NTS

DWG. NO: SK-3

18315S/19179S/  
JOB NO: 20176S

REV: 2

THIS DOCUMENT IS THE PROPERTY OF MOORE AND ASSOCIATES ENGINEERING AND CONSULTING. THE UNAUTHORIZED REPRODUCTION, COPYING, OR OTHERWISE USE OF THIS DOCUMENT IS STRICTLY PROHIBITED AND ANY INFRINGEMENT THEREUPON MAY BE SUBJECT TO LEGAL ACTION.

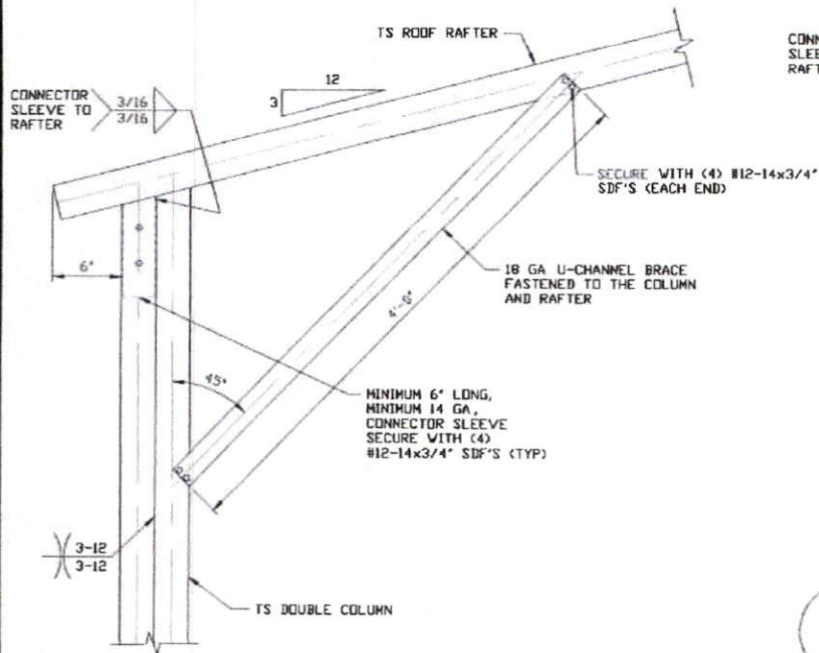

**1A**  
**BOX EAVE RAFTER/CORNER POST**  
**CONNECTION DETAIL**  
**FOR HEIGHTS 12'-0" < TO <= 16'-0"**  
 SCALE: NTS

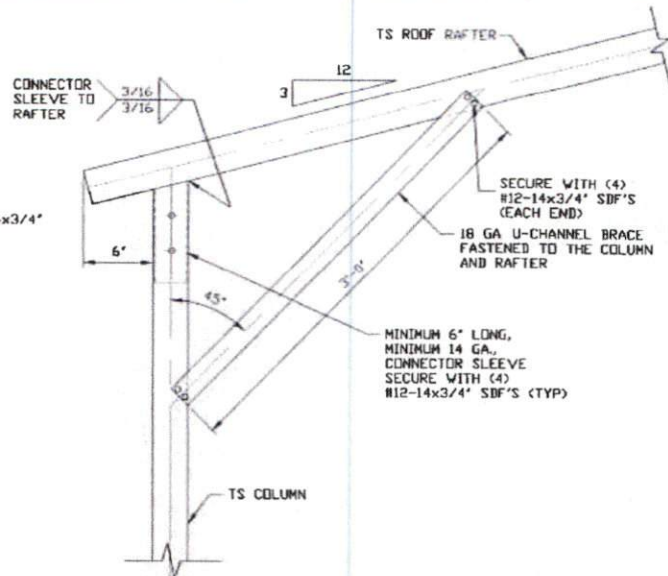

**1C**  
**BOX EAVE RAFTER/CORNER POST**  
**CONNECTION DETAIL**  
**FOR HEIGHTS <= 10'-0"**  
 SCALE: NTS

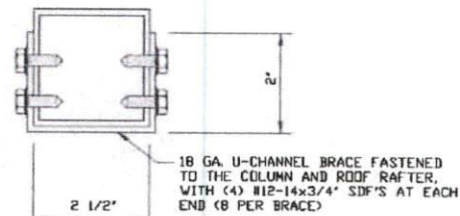

**BRACE SECTION**  
 SCALE: NTS

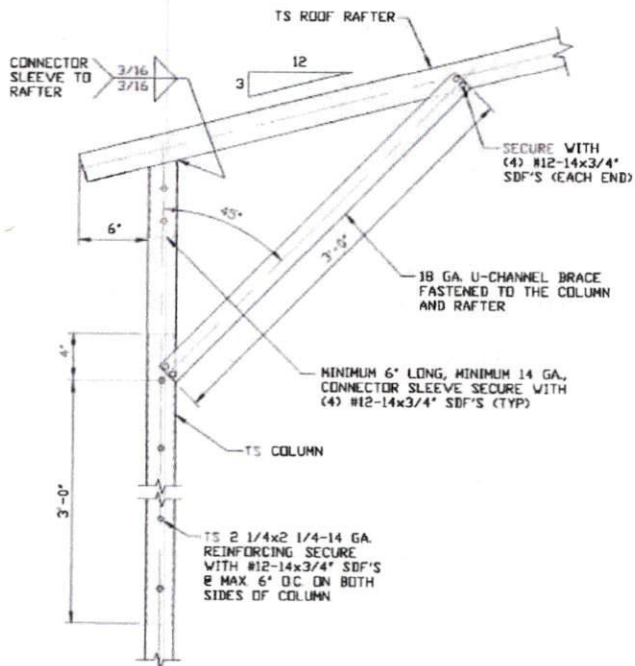

**1B**  
**BOX EAVE RAFTER/CORNER POST**  
**CONNECTION DETAIL**  
**FOR HEIGHTS 10'-0" < TO <= 12'-0"**  
 SCALE: NTS

**MOORE AND ASSOCIATES**  
**ENGINEERING AND CONSULTING, INC.**

**DRAWN BY: JG**

**CHECKED BY: PH**

**PROJECT MGR: WSM**

**CLIENT: NC CARPORTS**

**NC CARPORTS AND GARAGES, LLC**  
 309 S. DEPOT STREET  
 PILOT MOUNTAIN, NC 27041  
 30'-0" x 16'-0" ENCLOSED STRUCTURE

**DATE: 7-2-20**

**SCALE: NTS**

**18315S/19179S/**  
**JOB NO: 20176S**

**SHT. 5**

**DWG. NO: SK-3**

**REV: 2**

THIS DOCUMENT IS THE PROPERTY OF MOORE AND ASSOCIATES ENGINEERING AND CONSULTING. THE UNAUTHORIZED REPRODUCTION, COPYING, OR OTHERWISE USE OF THIS DOCUMENT IS STRICTLY PROHIBITED AND ANY INFRINGEMENT THEREUPON MAY BE SUBJECT TO LEGAL ACTION.

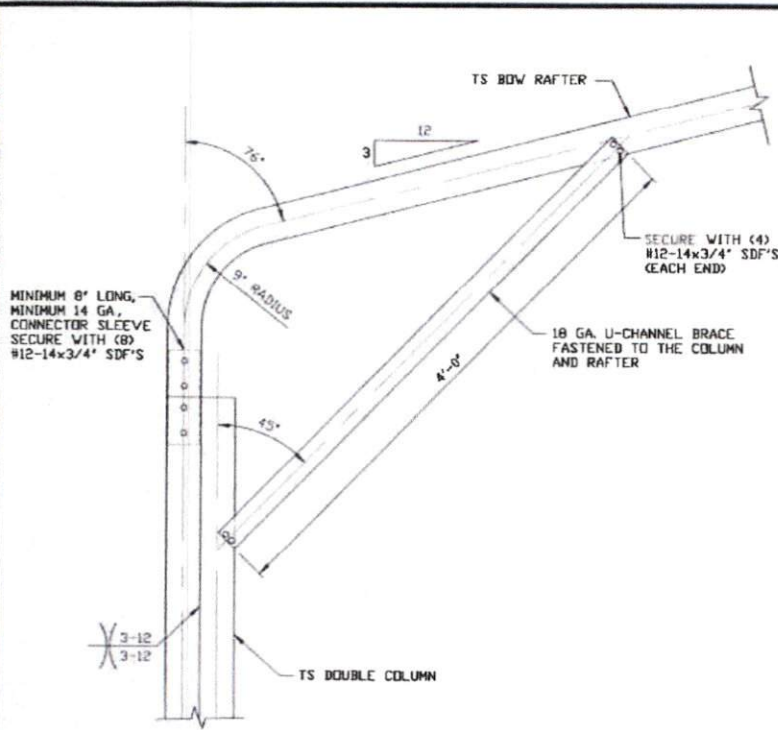

1A

**BOX EAVE RAFTER/CORNER POST CONNECTION DETAIL FOR HEIGHTS 12'-0" < TO <= 16'-0"**  
SCALE: NTS

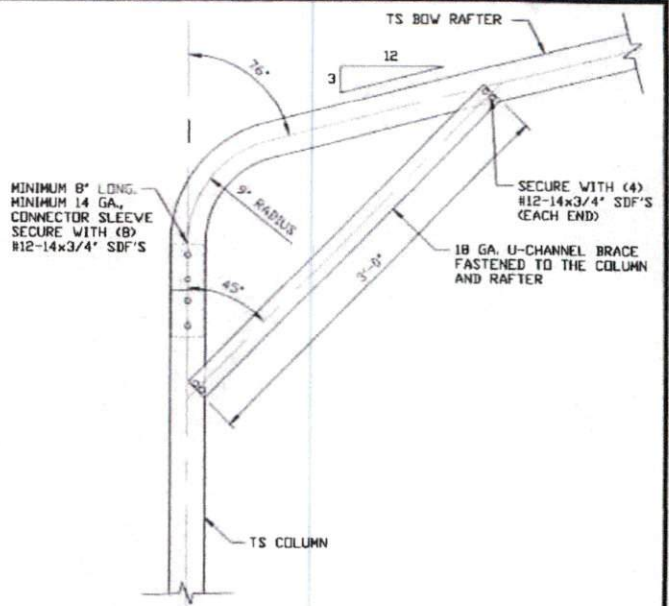

1C

**BOX EAVE RAFTER/CORNER POST CONNECTION DETAIL FOR HEIGHTS <= 10'-0"**  
SCALE: NTS

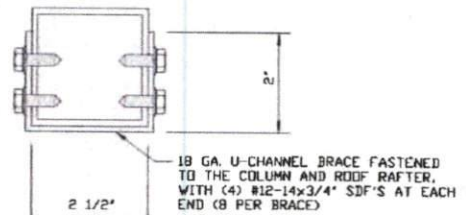

1B

**BOW RAFTER/CORNER POST CONNECTION DETAIL FOR HEIGHTS 10'-0" < TO <= 12'-0"**  
SCALE: NTS

**BRACE SECTION**  
SCALE: NTS

**MOORE AND ASSOCIATES ENGINEERING AND CONSULTING, INC.**

DRAWN BY: JG

CHECKED BY: PH

PROJECT MGR: WSM

CLIENT: NC CARPORTS

NC CARPORTS AND GARAGES, LLC  
309 S. DEPOT STREET  
PILOT MOUNTAIN, NC 27041  
30'-0" x 16'-0" ENCLOSED STRUCTURE

DATE: 7-2-20

SHT. 6

SCALE: NTS

DWG. NO: SK-3

18315S/19179S/  
JOB NO: 20176S

REV: 2

THIS DOCUMENT IS THE PROPERTY OF MOORE AND ASSOCIATES ENGINEERING AND CONSULTING. THE UNAUTHORIZED REPRODUCTION, COPYING, OR OTHERWISE USE OF THIS DOCUMENT IS STRICTLY PROHIBITED AND ANY INFRINGEMENT THEREUPON MAY BE SUBJECT TO LEGAL ACTION.

## BASE RAIL ANCHORAGE OPTIONS

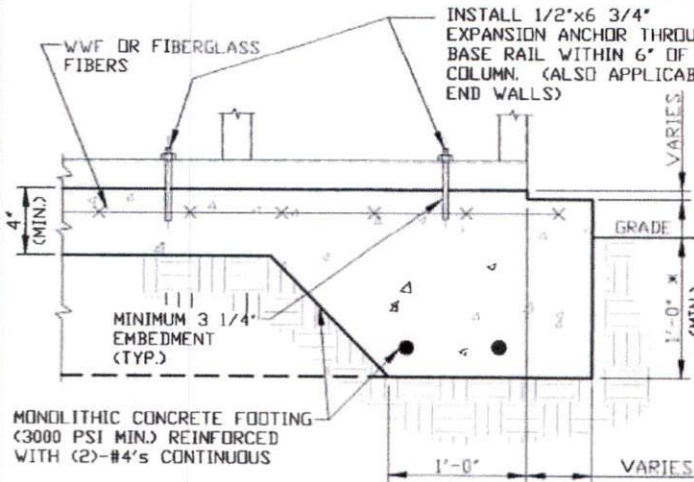

2A

### CONCRETE MONOLITHIC SLAB BASE RAIL ANCHORAGE

SCALE: NTS  
MINIMUM ANCHOR EDGE DISTANCE IS 4".  
\* COORDINATE WITH LOCAL BUILDING CODE  
AND/OR DGD REGARDING MINIMUM FROST DEPTH  
(LENGTH).

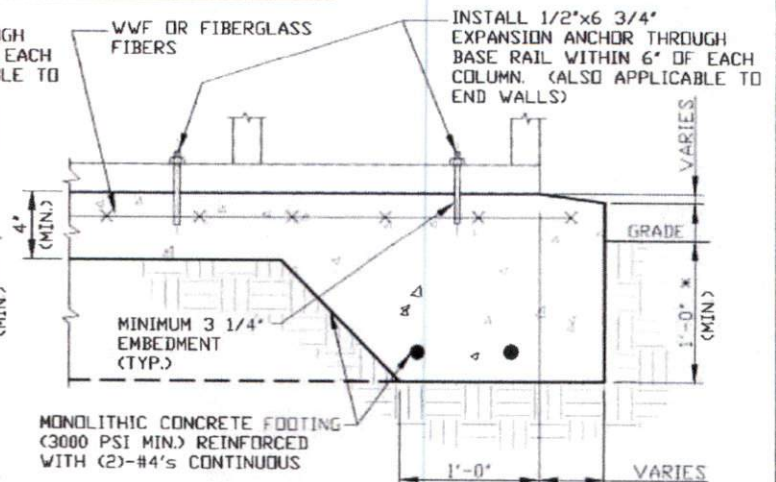

2B

### CONCRETE MONOLITHIC SLAB BASE RAIL ANCHORAGE

SCALE: NTS  
MINIMUM ANCHOR EDGE DISTANCE IS 4".  
\* COORDINATE WITH LOCAL BUILDING CODE  
AND/OR DGD REGARDING MINIMUM FROST DEPTH  
(LENGTH).

## GENERAL NOTES

NOTE: CONCRETE MONOLITHIC SLAB DESIGN BASED ON MINIMUM SOIL BEARING CAPACITY OF 1,500 PSF.

### CONCRETE:

CONCRETE SHALL HAVE A MINIMUM SPECIFIED COMPRESSIVE STRENGTH OF 3,000 PSI AT 28 DAYS.

### COVER OVER REINFORCING STEEL:

FOR FOUNDATIONS, MINIMUM CONCRETE COVER OVER REINFORCING BARS SHALL BE PER ACI-318:  
3" IN FOUNDATIONS WHERE THE CONCRETE IS CAST AGAINST AND PERMANENTLY IN CONTACT WITH THE EARTH OR EXPOSED TO THE EARTH OR WEATHER, AND 1 1/2" ELSEWHERE.

### REINFORCING STEEL:

THE TURNDOWN REINFORCING STEEL SHALL BE ASTM A615 GRADE 60. THE SLAB REINFORCEMENT SHALL BE WELDED WIRE FABRIC MEETING ASTM A185 OR FIBERGLASS FIBER REINFORCEMENT.

### REINFORCEMENT MAY BE BENT IN THE SHOP OR THE FIELD PROVIDED:

1. REINFORCEMENT IS BENT COLD.
2. THE DIAMETER OF THE BEND, MEASURED ON THE INSIDE OF THE BAR, IS NOT LESS THAN SIX-BAR DIAMETERS.
3. REINFORCEMENT PARTIALLY EMBEDDED IN CONCRETE SHALL NOT BE FIELD BENT.

### HELIX ANCHOR NOTES:

1. FOR VERY DENSE AND/OR CEMENTED SANDS, COARSE GRAVEL AND COBBLES, CALICHE, PRELOADED SILTS AND CLAYS, USE MINIMUM (2) 4" HELICES WITH MINIMUM 30" EMBEDMENT OR SINGLE 6" HELIX WITH MINIMUM 50" EMBEDMENT.
2. FOR CORAL USE MINIMUM (2) 4" HELICES WITH MINIMUM 30" EMBEDMENT OR SINGLE 6" HELIX WITH MINIMUM 50" EMBEDMENT.
3. FOR MEDIUM DENSE COARSE SANDS, SANDY GRAVELS, VERY STIFF SILTS, AND CLAYS USE MINIMUM (2) 4" HELICES WITH MINIMUM 30 INCH EMBEDMENT OR SINGLE 6" HELIX WITH MINIMUM 50" EMBEDMENT.
4. FOR LOOSE TO MEDIUM DENSE SANDS, FIRM TO STIFF CLAYS AND SILTS ALLUVIAL FILL, USE MINIMUM (2) 6" HELICES WITH MINIMUM 50" EMBEDMENT.
5. FOR VERY LOSE TO MEDIUM DENSE SANDS, FIRM TO STIFFER CLAYS AND SILTS, ALLUVIAL FILL, USE MINIMUM (2) 8" HELICES WITH MINIMUM 60" EMBEDMENT.

**MOORE AND ASSOCIATES  
ENGINEERING AND CONSULTING, INC.**

DRAWN BY: JG

CHECKED BY: PH

PROJECT MGR: WSM

CLIENT: NC CARPORTS

NC CARPORTS AND GARAGES, LLC  
309 S. DEPOT STREET  
PILOT MOUNTAIN, NC 27041  
30'-0" x 16'-0" ENCLOSED STRUCTURE

DATE: 7-2-20

SHT. 7

SCALE: NTS

DWG. NO: SK-3

183153/19179S/  
JOB NO: 20176S

REV: 2

THIS DOCUMENT IS THE PROPERTY OF MOORE AND ASSOCIATES ENGINEERING AND CONSULTING. THE UNAUTHORIZED REPRODUCTION, COPYING, OR OTHERWISE USE OF THIS DOCUMENT IS STRICTLY PROHIBITED AND ANY INFRINGEMENT THEREUPON MAY BE SUBJECT TO LEGAL ACTION.

## BASE RAIL ANCHORAGE OPTIONS

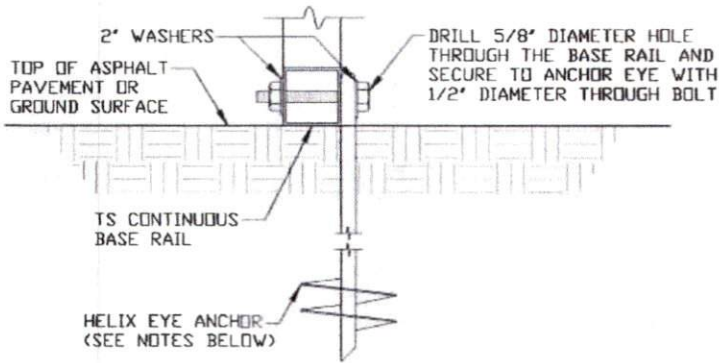

### 2C GROUND BASE HELIX ANCHORAGE

SCALE: NTS  
(CAN BE USED FOR ASPHALT)

\* COORDINATE WITH LOCAL BUILDING CODE AND/OR D REGARDING MINIMUM FROST DEPTH (LENGTH).

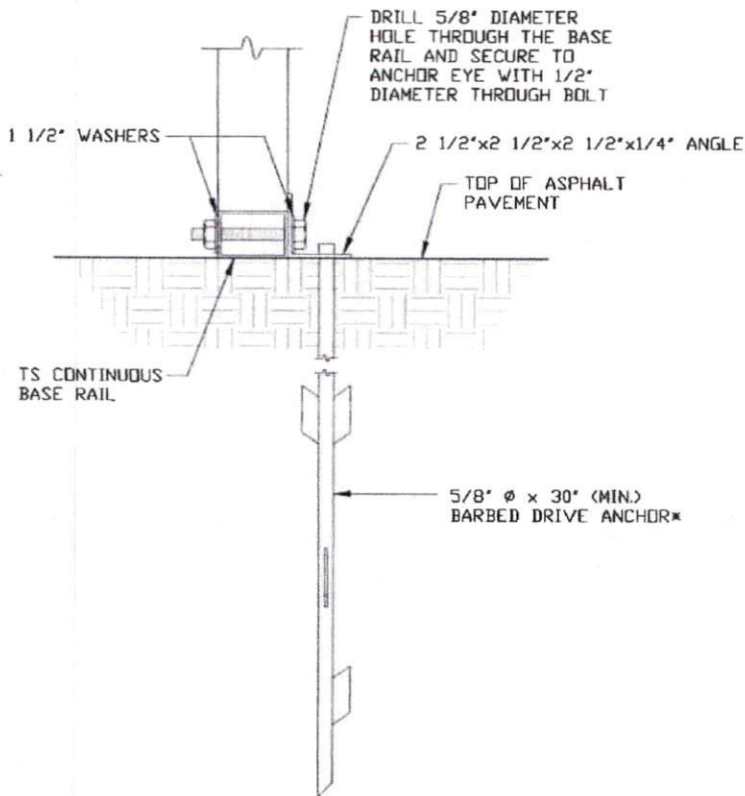

### 2D ASPHALT BASE ANCHORAGE

SCALE: NTS  
\* COORDINATE WITH LOCAL BUILDING CODE AND/OR D REGARDING MINIMUM FROST DEPTH (LENGTH).

**MOORE AND ASSOCIATES  
ENGINEERING AND CONSULTING, INC.**

**DRAWN BY:** JG

**CHECKED BY:** PH

**PROJECT MGR:** WSM

**CLIENT:** NC CARPORTS

NC CARPORTS AND GARAGES, LLC  
309 S. DEPOT STREET  
PILOT MOUNTAIN, NC 27041  
30'-0" x 16'-0" ENCLOSED STRUCTURE

**DATE:** 7-2-20

**SCALE:** NTS

**JOB NO:** 18315S/19179S/  
20176S

**SHT.** 7A

**DWG. NO:** SK-3

**REV.:** 2

THIS DOCUMENT IS THE PROPERTY OF MOORE AND ASSOCIATES ENGINEERING AND CONSULTING. THE UNAUTHORIZED REPRODUCTION, COPYING, OR OTHERWISE USE OF THIS DOCUMENT IS STRICTLY PROHIBITED AND ANY INFRINGEMENT THEREUPON MAY BE SUBJECT TO LEGAL ACTION.

# BOX EAVE RAFTER END WALL AND SIDE WALL OPENINGS

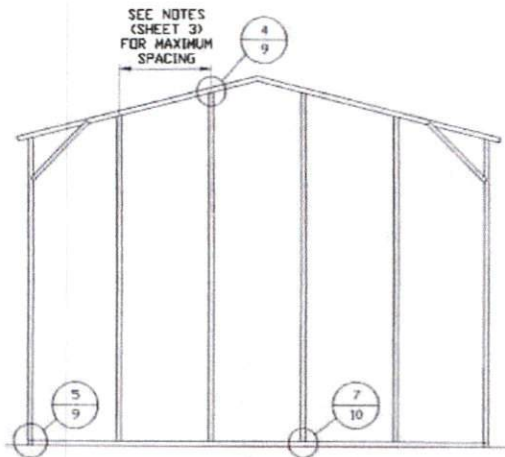

**TYPICAL BOX EAVE RAFTER  
END WALL FRAMING SECTION**

SCALE: NTS

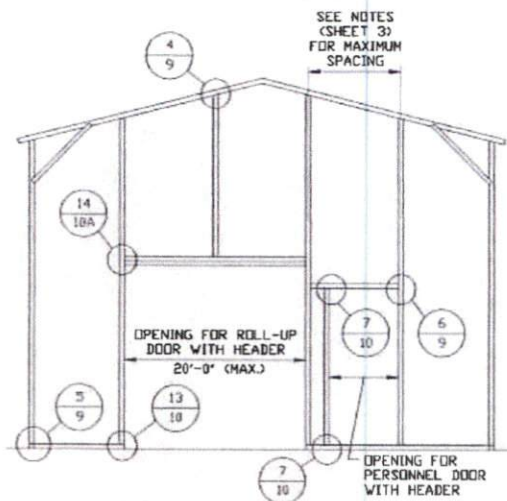

**TYPICAL BOX EAVE RAFTER END  
WALL OPENINGS FRAMING SECTION**

SCALE: NTS

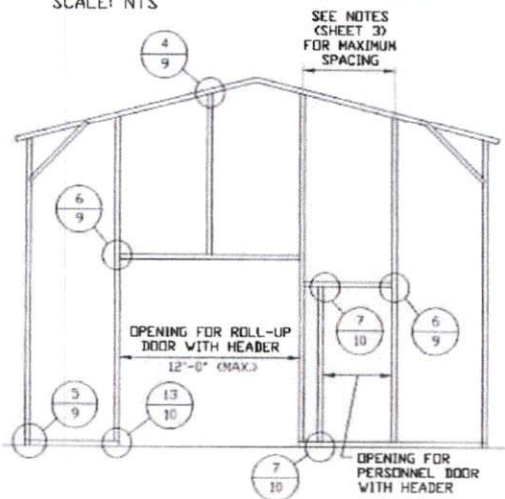

**TYPICAL BOX EAVE RAFTER END  
WALL OPENINGS FRAMING SECTION**

SCALE: NTS

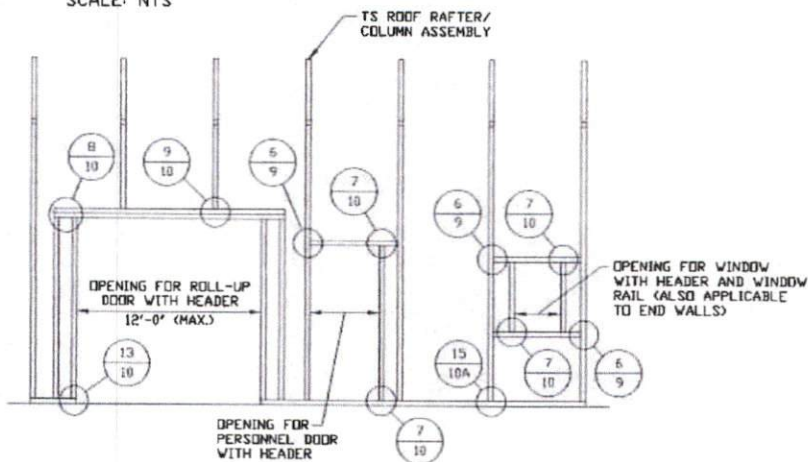

**TYPICAL BOX EAVE RAFTER  
SIDE WALL OPENINGS FRAMING SECTION**

SCALE: NTS

**MOORE AND ASSOCIATES  
ENGINEERING AND CONSULTING, INC.**

DRAWN BY: JG

CHECKED BY: PH

PROJECT MGR: WSM

CLIENT: NC CARPORTS

NC CARPORTS AND GARAGES, LLC  
309 S. DEPOT STREET  
PILOT MOUNTAIN, NC 27041  
30'-0" x 16'-0" ENCLOSED STRUCTURE

DATE: 7-2-20

SHT. 8

SCALE: NTS

DWG. NO: SK-3

183155/19179S/

JOB NO: 20176S

REV: 2

THIS DOCUMENT IS THE PROPERTY OF MOORE AND ASSOCIATES ENGINEERING AND CONSULTING. THE UNAUTHORIZED REPRODUCTION, COPYING, OR OTHERWISE USE OF THIS DOCUMENT IS STRICTLY PROHIBITED AND ANY INFRINGEMENT THEREUPON MAY BE SUBJECT TO LEGAL ACTION.

# BOX EAVE RAFTER END WALL AND SIDE WALL OPENINGS

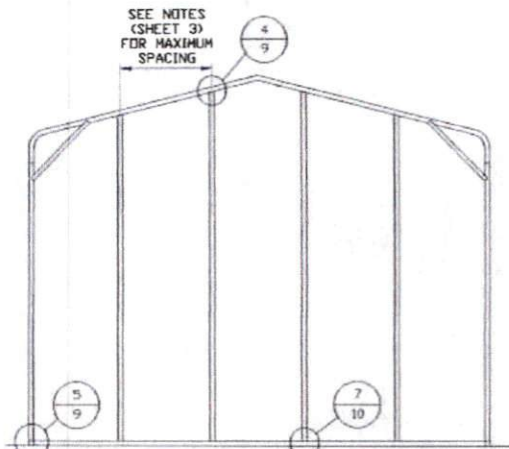

**TYPICAL BOX EAVE RAFTER END WALL FRAMING SECTION**

SCALE: NTS

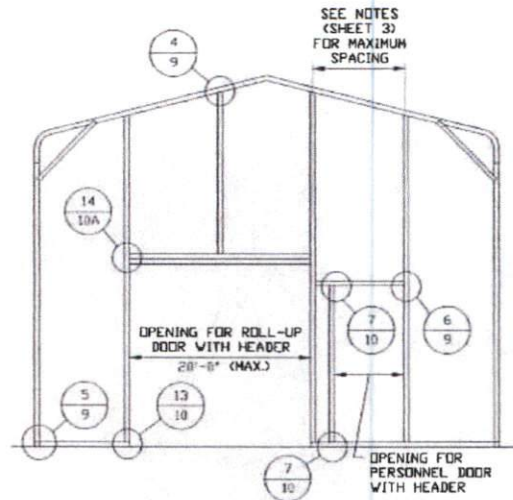

**TYPICAL BOX EAVE RAFTER END WALL OPENINGS FRAMING SECTION**

SCALE: NTS

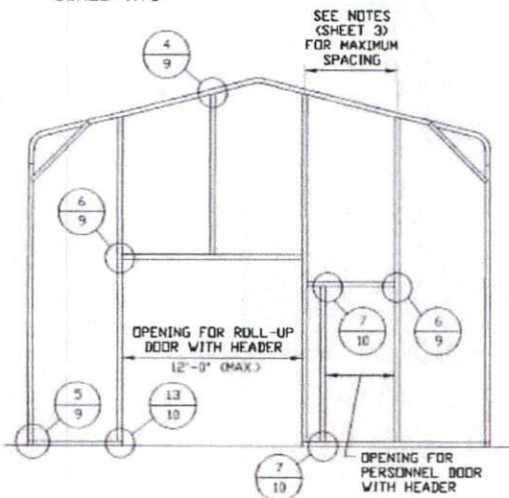

**TYPICAL BOX EAVE RAFTER END WALL OPENINGS FRAMING SECTION**

SCALE: NTS

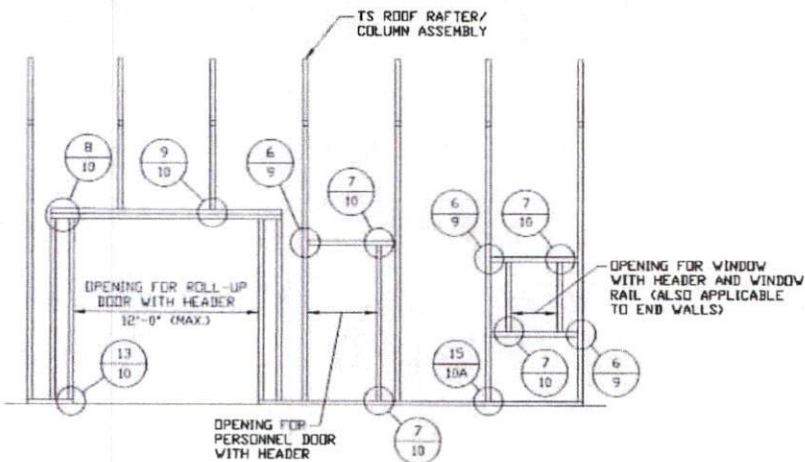

**TYPICAL BOX EAVE RAFTER SIDE WALL OPENINGS FRAMING SECTION**

SCALE: NTS

**MOORE AND ASSOCIATES  
ENGINEERING AND CONSULTING, INC.**

**DRAWN BY:** JG

**CHECKED BY:** PH

**PROJECT MGR:** WSH

**CLIENT:** NC CARPORTS

NC CARPORTS AND GARAGES, LLC  
309 S. DEPOT STREET  
PILOT MOUNTAIN, NC 27041  
30'-0"x16'-0" ENCLOSED STRUCTURE

**DATE:** 7-2-20

**SHT:** 8A

**SCALE:** NTS

**DWG. NO.:** SK-3

**JOB NO.:** 18315S/19179S/  
20176S

**REV.:** 2

THIS DOCUMENT IS THE PROPERTY OF MOORE AND ASSOCIATES ENGINEERING AND CONSULTING. THE UNAUTHORIZED REPRODUCTION, COPYING, OR OTHERWISE USE OF THIS DOCUMENT IS STRICTLY PROHIBITED AND ANY INFRINGEMENT THEREUPON MAY BE SUBJECT TO LEGAL ACTION.



## CONNECTION DETAILS

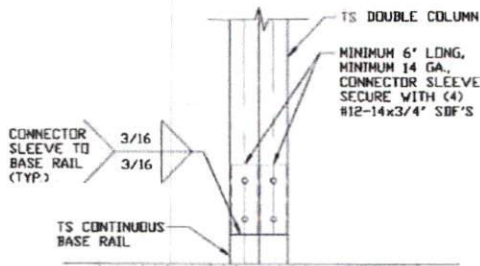

**3A** POST/BASE RAIL CONNECTION DETAIL  
SCALE: NTS

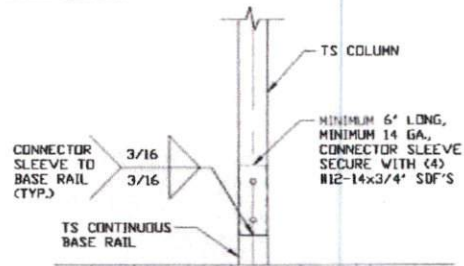

**3B** POST/BASE RAIL CONNECTION DETAIL  
SCALE: NTS

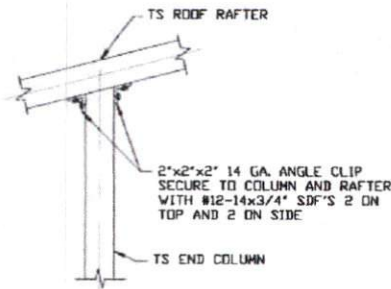

**4** END COLUMN/RAFTER CONNECTION DETAIL  
SCALE: NTS

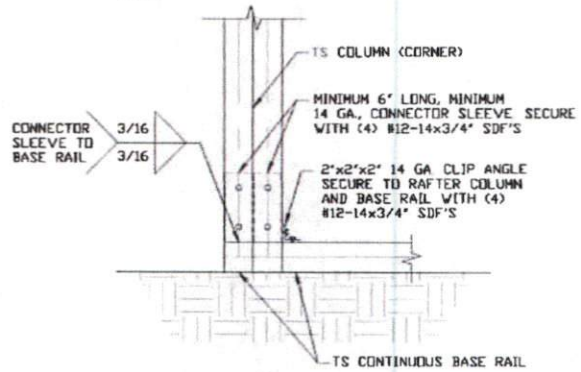

**5A** END COLUMN/BASE RAIL CONNECTION DETAIL  
SCALE: NTS

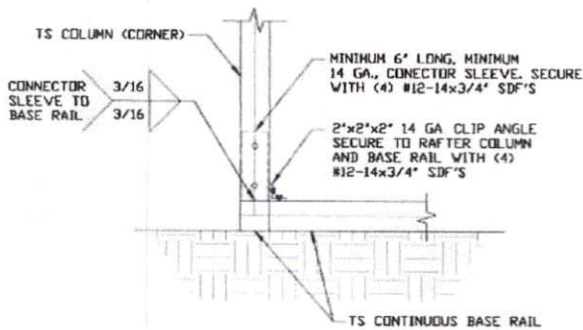

**5B** END COLUMN/BASE RAIL CONNECTION DETAIL  
SCALE: NTS

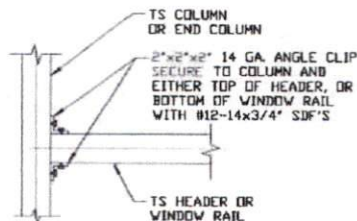

**6** COLUMN OR WINDOW RAIL TO POST CONNECTION DETAIL  
SCALE: NTS

**MOORE AND ASSOCIATES  
ENGINEERING AND CONSULTING, INC.**

DRAWN BY: JG

CHECKED BY: PH

PROJECT MGR: WSM

CLIENT: NC CARPORTS

NC CARPORTS AND GARAGES, LLC  
309 S. DEPOT STREET  
PILOT MOUNTAIN, NC 27041  
30'-0" x 16'-0" ENCLOSED STRUCTURE

DATE: 7-2-20

SHT. 9

SCALE: NTS

DWG. NO: SK-3

18315S/19179S/  
JOB NO: 20176S

REV: 2

THIS DOCUMENT IS THE PROPERTY OF MOORE AND ASSOCIATES ENGINEERING AND CONSULTING. THE UNAUTHORIZED REPRODUCTION, COPYING, OR OTHERWISE USE OF THIS DOCUMENT IS STRICTLY PROHIBITED AND ANY INFRINGEMENT THEREUPON MAY BE SUBJECT TO LEGAL ACTION.

# CONNECTION DETAILS

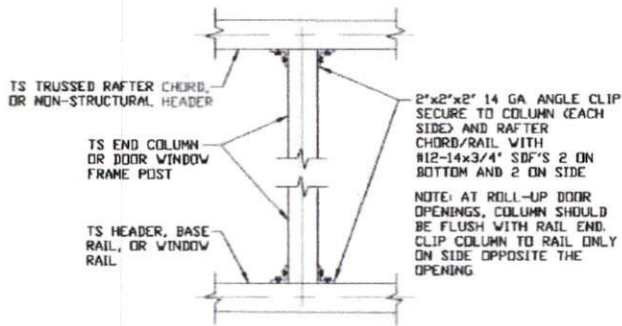

**7** COLUMN TO HEADER, BASE RAIL, OR WINDOW RAIL CONNECTION DETAIL

SCALE: NTS

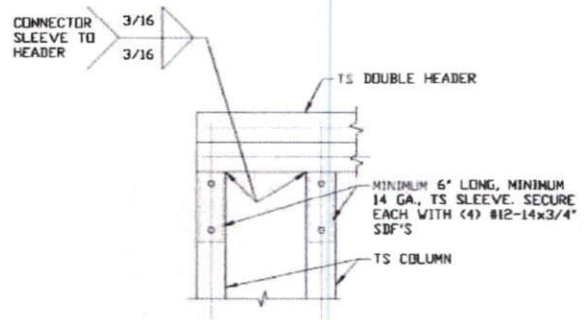

**8** DOUBLE HEADER/COLUMN CONNECTION DETAIL

SCALE: NTS

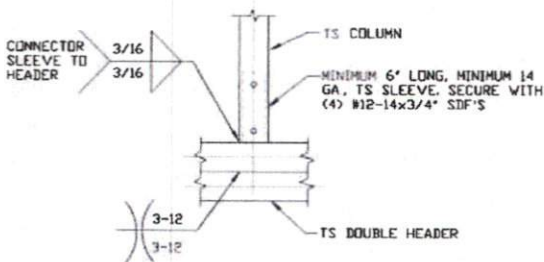

**9** COLUMN/DOUBLE HEADER CONNECTION DETAIL

SCALE: NTS

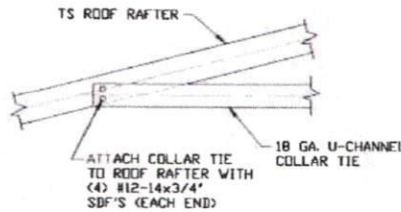

**10** COLLAR TIE CONNECTION DETAIL

SCALE: NTS

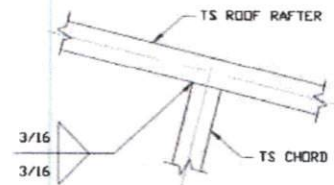

**11** RAFTER TO CHORD CONNECTION DETAIL

SCALE: NTS

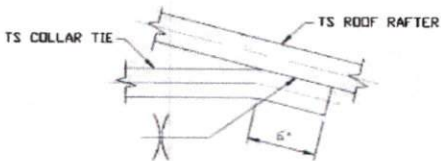

**12** COLLAR TIE CONNECTION DETAIL

SCALE: NTS

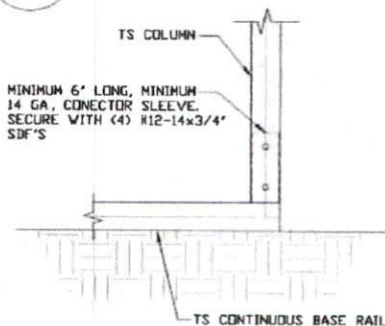

**13** COLUMN/BASE RAIL CONNECTION DETAIL

SCALE: NTS

**MOORE AND ASSOCIATES  
ENGINEERING AND CONSULTING, INC.**

DRAWN BY: JG

CHECKED BY: PH

PROJECT MGR: WSM

CLIENT: NC CARPORTS

NC CARPORTS AND GARAGES, LLC  
309 S. DEPOT STREET  
PILOT MOUNTAIN, NC 27041  
30'-0" x 16'-0" ENCLOSED STRUCTURE

DATE: 7-2-20

SHT. 10

SCALE: NTS

DWG. NO: SK-3

18315S/19179S/  
JOB NO: 20176S

REV: 2

THIS DOCUMENT IS THE PROPERTY OF MOORE AND ASSOCIATES ENGINEERING AND CONSULTING. THE UNAUTHORIZED REPRODUCTION, COPYING, OR OTHERWISE USE OF THIS DOCUMENT IS STRICTLY PROHIBITED AND ANY INFRINGEMENT THEREUPON MAY BE SUBJECT TO LEGAL ACTION.

## CONNECTION DETAILS

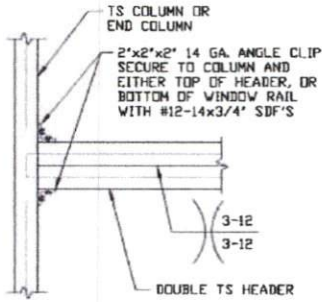

**DOUBLE HEADER  
TO COLUMN  
CONNECTION DETAIL**

14

SCALE: NTS

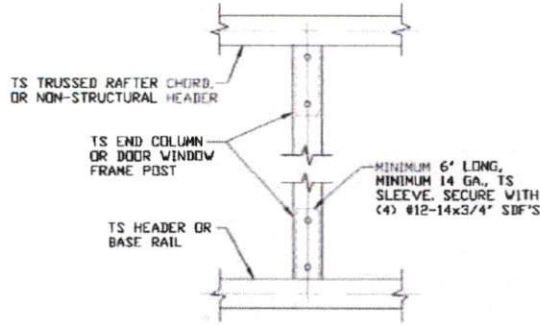

**COLUMN TO HEADER  
OR BASE RAIL  
CONNECTION DETAIL**

15

SCALE: NTS

**MOORE AND ASSOCIATES  
ENGINEERING AND CONSULTING, INC.**

DRAWN BY: JG

CHECKED BY: PH

PROJECT MGR: WSM

CLIENT: NC CARPORTS

NC CARPORTS AND GARAGES, LLC  
309 S. DEPOT STREET  
PILOT MOUNTAIN, NC 27041  
30'-0" x 16'-0" ENCLOSED STRUCTURE

DATE: 7-2-20

SHT. 10A

SCALE: NTS

DWG. NO: SK-3

18315S/19179S/  
JOB NO: 20176S

REV: 2

THIS DOCUMENT IS THE PROPERTY OF MOORE AND ASSOCIATES ENGINEERING AND CONSULTING. THE UNAUTHORIZED REPRODUCTION, COPYING, OR OTHERWISE USE OF THIS DOCUMENT IS STRICTLY PROHIBITED AND ANY INFRINGEMENT THEREUPON MAY BE SUBJECT TO LEGAL ACTION.

# BOX EAVE RAFTER LEAN-TO OPTIONS

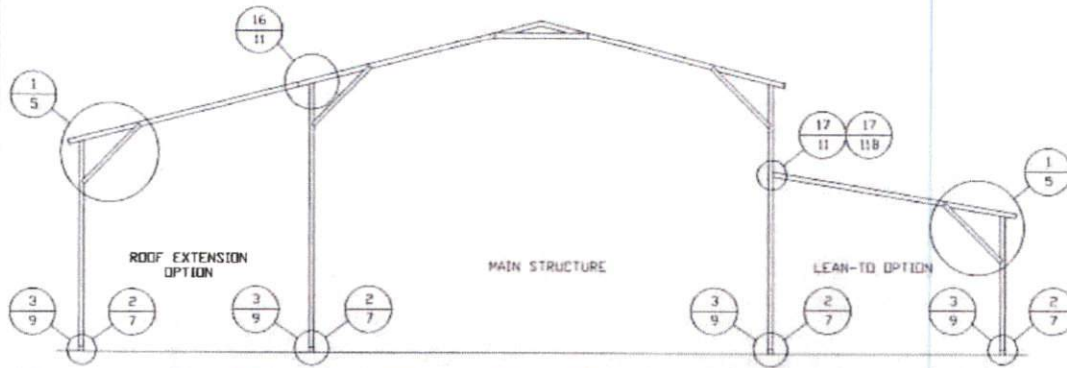

## TYPICAL BOX EAVE RAFTER LEAN-TO OPTIONS FRAMING SECTION (BOTH OPTIONS SHOWN)

SCALE: NTS

MAXIMUM WIDTH OF SINGLE MEMBER ROOF EXTENSION AND LEAN-TO OPTION IS 12'-0".  
 MAXIMUM WIDTH OF DOUBLE MEMBER ROOF EXTENSION AND LEAN-TO OPTION IS 16'-0".

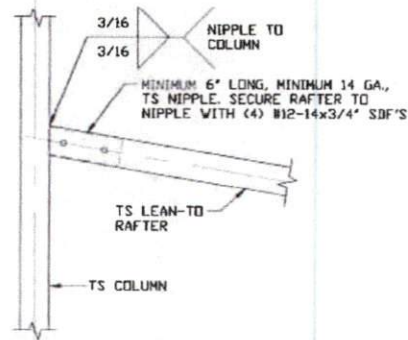
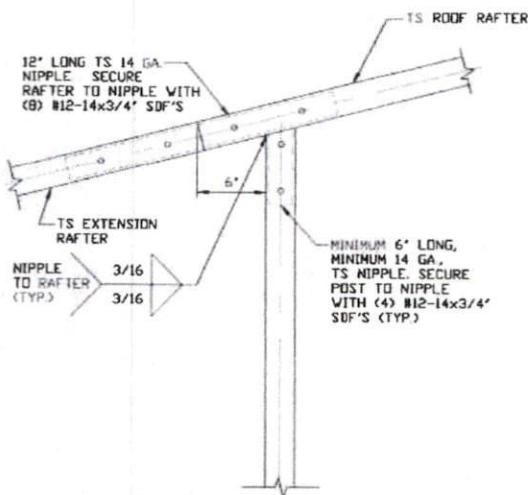

### LEAN-TO RAFTER TO RAFTER POST CONNECTION DETAIL FOR WIDTHS ≤ 12'-0"

17A

SCALE: NTS

### ROOF EXTENSION RAFTER/CORNER POST DETAIL FOR WIDTHS ≤ 12'-0"

16

SCALE: NTS

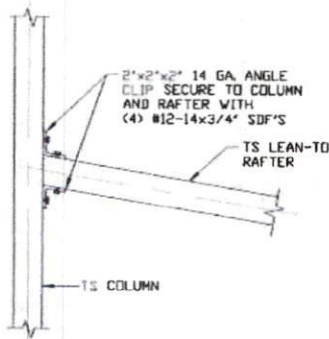

### LEAN-TO RAFTER TO RAFTER POST CONNECTION DETAIL FOR WIDTHS ≤ 12'-0"

17B

SCALE: NTS

**MOORE AND ASSOCIATES  
ENGINEERING AND CONSULTING, INC.**

DRAWN BY: JG

CHECKED BY: PH

PROJECT MGR: WSM

CLIENT: NC CARPORTS

NC CARPORTS AND GARAGES, LLC  
 309 S. DEPOT STREET  
 PILOT MOUNTAIN, NC 27041  
 30'-0" x 16'-0" ENCLOSED STRUCTURE

DATE: 7-2-20

SHT. 11

SCALE: NTS

DWG. NO: SK-3

18315S/19179S/  
JOB NO: 20176S

REV: 2

THIS DOCUMENT IS THE PROPERTY OF MOORE AND ASSOCIATES ENGINEERING AND CONSULTING. THE UNAUTHORIZED REPRODUCTION, COPYING, OR OTHERWISE USE OF THIS DOCUMENT IS STRICTLY PROHIBITED AND ANY INFRINGEMENT THEREUPON MAY BE SUBJECT TO LEGAL ACTION.

## BOX EAVE RAFTER LEAN-TO OPTIONS

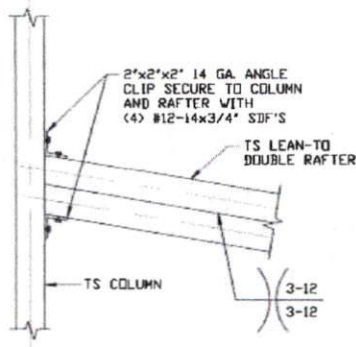

**LEAN-TO RAFTER TO RAFTER  
POST CONNECTION DETAIL FOR  
WIDTHS 12'-0" < TO ≤ 16'-0"**

17C

SCALE: NTS

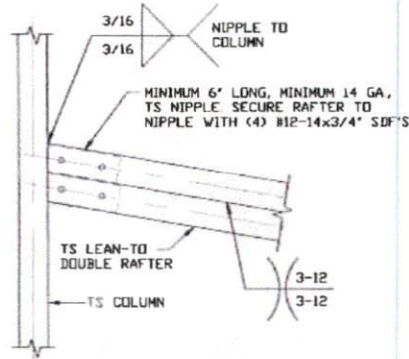

**LEAN-TO RAFTER TO RAFTER  
POST CONNECTION DETAIL FOR  
WIDTHS 12'-0" < TO ≤ 16'-0"**

17D

SCALE: NTS

**MOORE AND ASSOCIATES  
ENGINEERING AND CONSULTING, INC.**

DRAWN BY: JG

CHECKED BY: PH

PROJECT MGR: WSM

CLIENT: NC CARPORTS

NC CARPORTS AND GARAGES, LLC  
309 S. DEPOT STREET  
PILOT MOUNTAIN, NC 27041  
30'-0" x 16'-0" ENCLOSED STRUCTURE

DATE: 7-2-20

SHT. 11A

SCALE: NTS

DWG. NO: SK-3

18315S/19179S/  
JOB NO: 20176S

REV: 2

THIS DOCUMENT IS THE PROPERTY OF MOORE AND ASSOCIATES ENGINEERING AND CONSULTING. THE UNAUTHORIZED REPRODUCTION, COPYING, OR OTHERWISE USE OF THIS DOCUMENT IS STRICTLY PROHIBITED AND ANY INFRINGEMENT THEREUPON MAY BE SUBJECT TO LEGAL ACTION.

# BOW EAVE RAFTER LEAN-TO OPTIONS

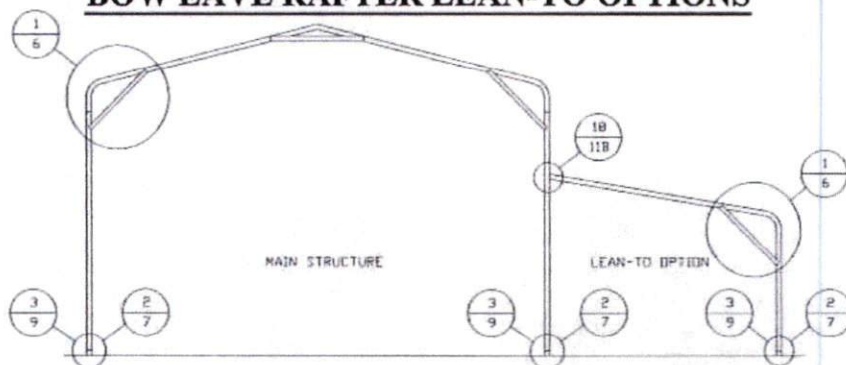

## TYPICAL BOW EAVE RAFTER LEAN-TO OPTIONS FRAMING SECTION

SCALE: NTS  
 MAXIMUM WIDTH OF SINGLE MEMBER LEAN-TO OPTION IS 12'-0".  
 MAXIMUM WIDTH OF DOUBLE MEMBER LEAN-TO OPTION IS 16'-0".

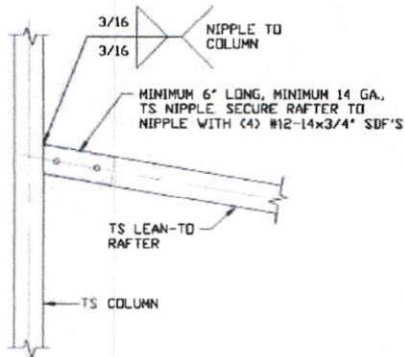

18A

LEAN-TO RAFTER TO  
 RAFTER POST  
 CONNECTION DETAIL  
 FOR WIDTHS  $\le 12'-0''$

SCALE: NTS

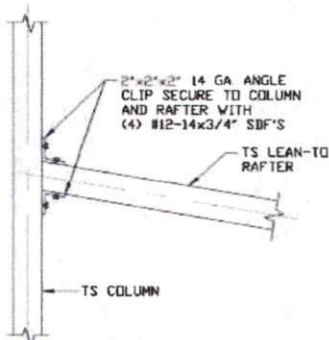

18B

LEAN-TO RAFTER  
 TO RAFTER POST  
 CONNECTION DETAIL  
 FOR WIDTHS  $\le 12'-0''$

SCALE: NTS

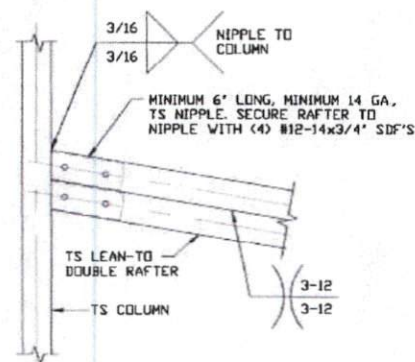

18C

LEAN-TO RAFTER TO RAFTER  
 POST CONNECTION DETAIL  
 FOR WIDTHS  
 $12'-0'' < TO \le 16'-0''$

SCALE: NTS

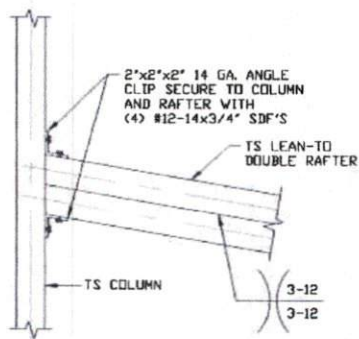

18D

LEAN-TO RAFTER TO RAFTER  
 POST CONNECTION DETAIL  
 FOR WIDTHS  
 $12'-0'' < TO \le 16'-0''$

SCALE: NTS

MOORE AND ASSOCIATES  
 ENGINEERING AND CONSULTING, INC.

DRAWN BY: JG

CHECKED BY: PH

PROJECT MGR: WSM

CLIENT: NC CARPORTS

NC CARPORTS AND GARAGES, LLC  
 309 S. DEPOT STREET  
 PILOT MOUNTAIN, NC 27041  
 30'-0" x 16'-0" ENCLOSED STRUCTURE

DATE: 7-2-20

SHT. 11B

SCALE: NTS

DWG. NO: SK-3

18315S/19179S/  
 JOB NO: 20176S

REV: 2

THIS DOCUMENT IS THE PROPERTY OF MOORE AND ASSOCIATES ENGINEERING AND CONSULTING. THE UNAUTHORIZED REPRODUCTION, COPYING, OR OTHERWISE USE OF THIS DOCUMENT IS STRICTLY PROHIBITED AND ANY INFRINGEMENT THEREUPON MAY BE SUBJECT TO LEGAL ACTION.

**BOX EAVE RAFTER VERTICAL ROOF/SIDING OPTION**

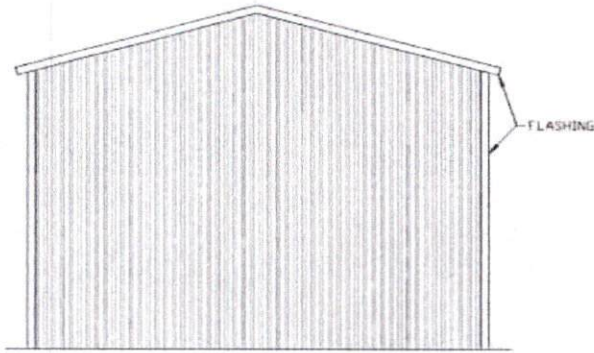

**TYPICAL END ELEVATION  
VERTICAL ROOF/SIDING**  
SCALE: NTS

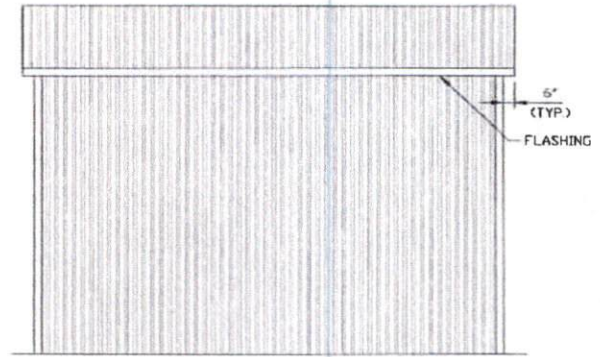

**TYPICAL SIDE ELEVATION  
VERTICAL ROOF/SIDING**  
SCALE: NTS

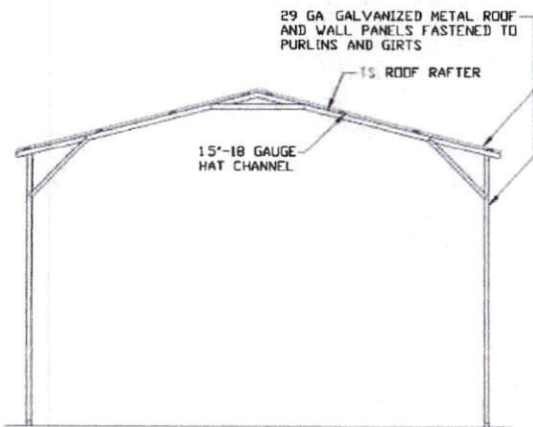

**TYPICAL SECTION  
VERTICAL ROOF/SIDING OPTION**  
SCALE: NTS

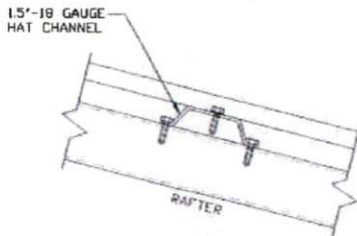

**PANEL ATTACHMENT**  
(ALTERNATE FOR VERTICAL ROOF PANELS)  
SCALE: NTS

**MOORE AND ASSOCIATES  
ENGINEERING AND CONSULTING, INC.**

DRAWN BY: JG

CHECKED BY: PH

PROJECT MGR: WSM

CLIENT: NC CARPORTS

NC CARPORTS AND GARAGES, LLC  
309 S. DEPOT STREET  
PILOT MOUNTAIN, NC 27041  
30'-0" x 16'-0" ENCLOSED STRUCTURE

DATE: 7-2-20

SHT. 12

SCALE: NTS

DWG. NO SK-3

18315S/19179S/  
JOB NO: 20176S

REV: 2

THIS DOCUMENT IS THE PROPERTY OF MOORE AND ASSOCIATES ENGINEERING AND CONSULTING. THE UNAUTHORIZED REPRODUCTION, COPYING, OR OTHERWISE USE OF THIS DOCUMENT IS STRICTLY PROHIBITED AND ANY INFRINGEMENT THEREUPON MAY BE SUBJECT TO LEGAL ACTION.

## BOX EAVE RAFTER VERTICAL ROOF/SIDING OPTION

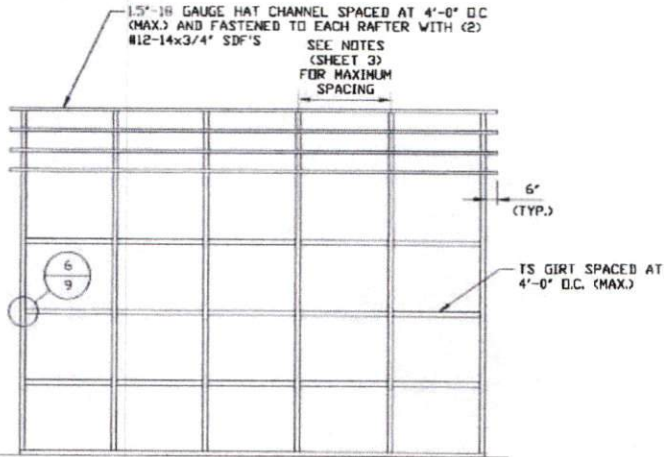

**TYPICAL FRAMING SECTION  
VERTICAL ROOF/SIDING OPTION  
WITH TS GIRTS**

SCALE: NTS

**MOORE AND ASSOCIATES  
ENGINEERING AND CONSULTING, INC.**

DRAWN BY: JG

CHECKED BY: PH

PROJECT MGR: WSM

CLIENT: NC CARPORTS

NC CARPORTS AND GARAGES, LLC  
309 S. DEPOT STREET  
PILOT MOUNTAIN, NC 27041  
30'-0" x 16'-0" ENCLOSED STRUCTURE

DATE: 7-2-20

SHT. 12A

SCALE: NTS

DWG. NO: SK-3

18315S/19179S/  
JOB NO: 20176S

REV: 2

THIS DOCUMENT IS THE PROPERTY OF MOORE AND ASSOCIATES ENGINEERING AND CONSULTING. THE UNAUTHORIZED REPRODUCTION, COPYING, OR OTHERWISE USE OF THIS DOCUMENT IS STRICTLY PROHIBITED AND ANY INFRINGEMENT THEREUPON MAY BE SUBJECT TO LEGAL ACTION.