

BASEPLATE DETAIL 1
(PLAN VIEW)
(TYP. OF 4)

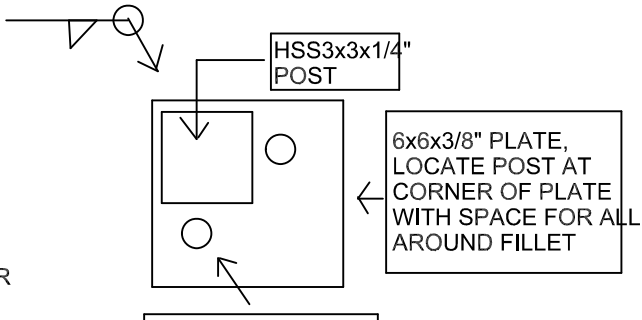

BASEPLATE DETAIL 2
(PLAN VIEW)
(TYP. OF 4)

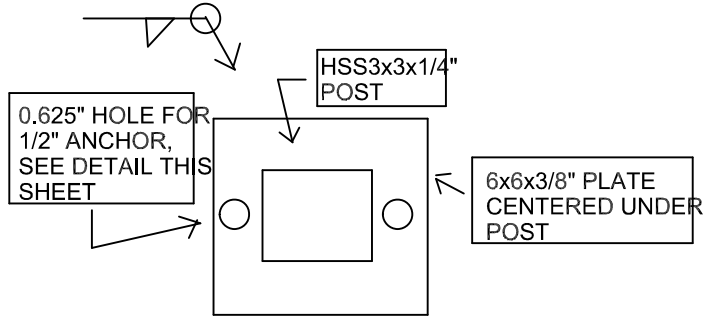

BASEPLATE DETAIL 3
(PLAN VIEW)
(TYP. OF 1)

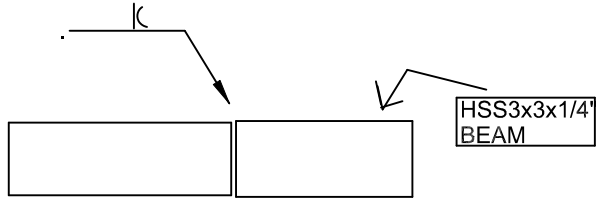

TYPICAL TUBE-END WELDING
(USE FILLET OR FLARE-BEVEL WELDS
AS APPROPRIATE FOR EACH JOINT)

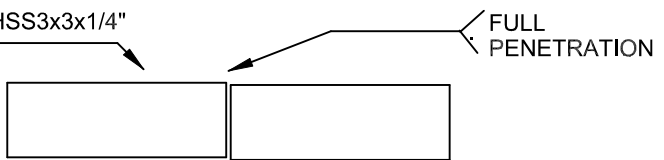

FULL-STRENGTH TUBE SPLICE (AS REQUIRED)
SPLICES ONLY TO OCCUR OVER POST

NOTE: CENTER BASEPLATE ON FOUNDATION, TYP. OF 9

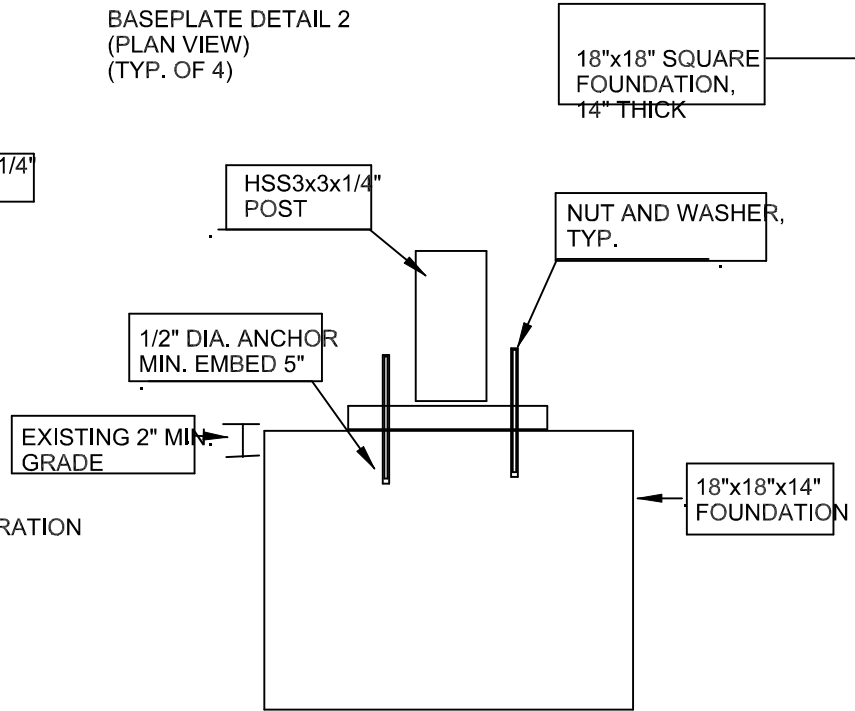

FOUNDATION
(ELEVATION VIEW)

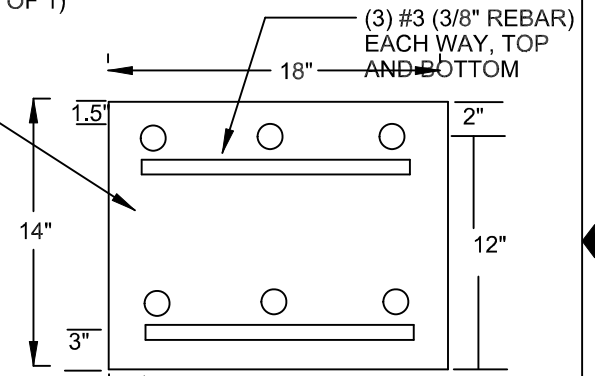

FOUNDATION DETAIL
(SECTION VIEW)
(TYP. OF 9)

THE WELDING MACHINE LLC			
DRAWN Cody	1-1-2013	RESIDENTIAL GARAGE DWG NUMBER 0000-0000	SIZE B
CHECKED Name	1-1-2013		
ENGINEER Name	1-1-2013		
APPROVED Name	1-1-2013		
SCALE 1:1	REV B	SHEET 5 OF 5	