

BUILDER / CONTRACTOR RESPONSIBILITIES

IT IS THE RESPONSIBILITY OF THE BUILDER/CONTRACTOR TO INSURE THAT ALL PROJECT PLANS AND SPECIFICATIONS COMPLY WITH THE APPLICABLE REQUIREMENTS OF ANY GOVERNING BUILDING AUTHORITIES. THE SUPPLYING OF SEALED ENGINEERING DATA AND DRAWINGS FOR THE METAL BUILDING SYSTEM DOES NOT IMPLY OR CONSTITUTE AN AGREEMENT THAT METALLIC BUILDING COMPANY OR ITS DESIGN ENGINEER IS ACTING AS THE ENGINEER OF RECORD OR DESIGN PROFESSIONAL FOR A CONSTRUCTION PROJECT.

THE CONTRACTOR MUST SECURE ALL REQUIRED APPROVALS AND PERMITS FROM THE APPROPRIATE AGENCY AS REQUIRED.

APPROVAL OF METALLIC'S DRAWINGS AND CALCULATIONS INDICATE THAT METALLIC BUILDING COMPANY CORRECTLY INTERPRETED AND APPLIED THE REQUIREMENTS OF THE CONTRACT DRAWINGS AND SPECIFICATIONS. (SECT. 4.2.1 AISC CODE OF STANDARD PRACTICES, 9TH ED.)

WHERE DISCREPANCIES EXIST BETWEEN METALLIC'S STRUCTURAL STEEL PLANS AND THE PLANS FOR OTHER TRADES, THE STRUCTURAL STEEL PLANS SHALL GOVERN. (SECT. 3.3 AISC CODE OF STANDARD PRACTICE 9TH ED.)

DESIGN CONSIDERATIONS OF ANY MATERIALS IN THE STRUCTURE WHICH ARE NOT FURNISHED BY METALLIC BUILDING COMPANY ARE THE RESPONSIBILITY OF THE CONTRACTORS AND ENGINEERS OTHER THAN METALLIC BUILDING COMPANY'S ENGINEERS UNLESS SPECIFICALLY INDICATED.

THE CONTRACTOR IS RESPONSIBLE FOR ALL ERECTION OF STEEL AND ASSOCIATED WORK IN COMPLIANCE WITH METALLIC BUILDING COMPANY'S "FOR CONSTRUCTION" DRAWINGS.

PRODUCTS SHIPPED TO BUILDER OR HIS CUSTOMER SHALL BE INSPECTED BY BUILDER IMMEDIATELY UPON ARRIVAL. CLAIMS FOR SHORTAGES OR DEFECTIVE MATERIAL IF NOT PACKAGED MUST BE MAILED TO METALLIC IN WRITING WITHIN FIVE (5) DAYS AFTER RECEIPT OF THE SHIPMENT. HOWEVER, IF A DEFECT IS OF SUCH A NATURE THAT REASONABLE VISUAL INSPECTION WOULD FAIL TO DISCLOSE IT, THEN THE CLAIM MUST BE MADE WITHIN FIVE (5) DAYS AFTER THE BUILDER LEARNS OF THE DEFECT. METALLIC WILL NOT BE LIABLE FOR ANY DEFECT UNLESS CLAIM IS MADE WITHIN ONE (1) YEAR AFTER DATE OF THE ORIGINAL SHIPMENT BY METALLIC TO BUILDER OR HIS CUSTOMER. METALLIC WILL BE GIVEN A REASONABLE OPPORTUNITY TO INSPECT DEFECTIVE MATERIALS UPON RECEIPT OF CLAIM BY BUILDER.

IF A DEFECT IS OF SUCH NATURE THAT IT CAN BE REMEDIED BY A FIELD OPERATION AT THE JOB SITE WITHOUT THE NECESSITY OF RETURNING THE MATERIAL TO METALLIC, THEN UPON WRITTEN AUTHORIZATION OF METALLIC THE BUILDER MAY REPAIR OR CAUSE THE MATERIAL TO BE REPAIRED AND METALLIC WILL REIMBURSE THE BUILDER FOR THE COST OF THE REPAIR IN ACCORDANCE WITH THE WRITTEN AUTHORIZATION.

ALL BRACING AS SHOWN AND PROVIDED BY METALLIC FOR THIS BUILDING IS REQUIRED AND SHALL BE INSTALLED BY THE ERECTOR AS A PERMANENT PART OF THE STRUCTURE.

TEMPORARY SUPPORTS, SUCH AS TEMPORARY GUYS, BRACES, FALSE WORK, CRIBBING OR OTHER ELEMENTS REQUIRED FOR THE ERECTION OPERATION WILL BE DETERMINED AND FURNISHED AND INSTALLED BY THE ERECTOR. THESE TEMPORARY SUPPORTS WILL SECURE THE STEEL FRAMING, OR ANY PARTLY ASSEMBLED STEEL FRAMING, AGAINST LOADS COMPARABLE IN INTENSITY TO THOSE FOR WHICH THE STRUCTURE WAS DESIGNED, RESULTING FROM WIND, SEISMIC FORCES AND ERECTION OPERATIONS, BUT NOT THE LOADS RESULTING FROM THE PERFORMANCE OF WORK BY OR THE ACTS OF OTHERS, NOR SUCH UNPREDICTABLE LOADS AS THOSE DUE TO TORNADO, EXPLOSION OR COLLISION. (SECT. 7.9.1 AISC CODE OF STANDARD PRACTICE, 9TH ED.)

DESIGN OF GUTTER AND DOWNSPOUT IS A FUNCTION OF THE RAINFALL INTENSITY AND AREA TO BE DRAINED. DESIGN PARAMETERS UTILIZED ARE IN ACCORDANCE WITH THE 1986 LOW RISE BUILDING SYSTEMS MANUAL AND/OR THE 9TH EDITION OF THE ARCHITECTURAL GRAPHIC STANDARDS, AS APPLICABLE. PROPER OWNER MAINTENANCE DICTATES THAT THE DRAINAGE SYSTEM BE KEPT FREE AND CLEAR OF DEBRIS AND/OR ICE AT ALL TIMES TO ENSURE PROPER FUNCTION OF THE GUTTER AND DOWNSPOUT. IN THOSE CASES WHERE THE OWNER/TENANT OF A PROPERTY IS UNWILLING OR UNABLE TO PROVIDE PROPER MAINTENANCE, ELIMINATION OF GUTTER SHOULD BE CONSIDERED AS AN ALTERNATIVE.

PRODUCT CERTIFICATIONS

METALLIC BUILDING COMPANY IS A MEMBER OF THE METAL BUILDING MANUFACTURERS ASSOCIATION. METALLIC BUILDING COMPANY'S FABRICATION AND PRODUCTS ARE COVERED BY ONE OR MORE OF THE FOLLOWING CERTIFICATIONS:

- APPROVED FABRICATOR OF PREFABRICATED BUILDINGS AND COMPONENTS. REFERENCE ICBO REPORT NO. FA-337
- SBCCI COMPLIANCE REPORT NO. 9461A
- AISC METAL BUILDING CERTIFICATION PROGRAM
- CITY OF HOUSTON APPROVED FABRICATOR (REGISTRATION NO. 164)
- WISCONSIN PRODUCT APPROVAL NUMBER 200115-M
- CLARK COUNTY, NEVADA APPROVED FABRICATOR
- CITY OF LOS ANGELES, CALIFORNIA APPROVED TYPE 1 FABRICATOR (LA#1604)
- CANADIAN WELDING BUREAU CERTIFICATION TO CSA STANDARD W47.1 IN DIVISION 1 (SYMBOL PY72(HOUSTON, TX))
- TEXAS DEPT. OF INSURANCE PRODUCT EVALUATION RC-34

APPROVAL NOTES

THE FOLLOWING CONDITIONS APPLY IN THE EVENT THAT THESE DRAWINGS ARE USED AS APPROVAL DRAWINGS:

A) IT IS IMPERATIVE THAT ANY CHANGES TO THESE DRAWINGS:

- BE MADE IN CONTRASTING INK.
- HAVE ALL INSTANCES OF CHANGE CLEARLY INDICATED.
- BE LEGIBLE AND UNAMBIGUOUS.

B) DATED SIGNATURE IS REQUIRED ON ALL PAGES.

C) MANUFACTURER RESERVES THE RIGHT TO RE-SUBMIT DRAWINGS WITH EXTENSIVE OR COMPLEX CHANGES REQUIRED TO AVOID MISFABRICATION. THIS MAY IMPACT THE DELIVERY SCHEDULE.

D) APPROVAL OF THESE DRAWINGS INDICATES CONCLUSIVELY THAT METALLIC HAS CORRECTLY INTERPRETED THE CONTRACT REQUIREMENTS, AND FURTHER CONSTITUTES AGREEMENT THAT THE BUILDING AS DRAWN, OR AS DRAWN WITH INDICATED CHANGES REPRESENTS THE TOTAL OF THE MATERIALS TO BE SUPPLIED BY MANUFACTURER.

E) ANY CHANGES NOTED ON THE DRAWINGS NOT IN CONFORMANCE WITH THE TERMS AND REQUIREMENTS OF THE CONTRACT BETWEEN MANUFACTURER AND ITS CUSTOMER ARE NOT BINDING ON MANUFACTURER UNLESS SUBSEQUENTLY SPECIFICALLY ACKNOWLEDGED AND AGREED TO IN WRITING BY CHANGE ORDER OR SEPARATE DOCUMENTATION. MANUFACTURER RECOGNIZES THAT RUBBER STAMPS ARE ROUTINELY USED FOR INDICATING APPROVAL, DISAPPROVAL, REJECTION, OR MERE REVIEW OF THE DRAWINGS SUBMITTED. HOWEVER, MANUFACTURER DOES NOT ACCEPT CHANGES OR ADDITIONS TO CONTRACTUAL TERMS AND CONDITIONS THAT MAY APPEAR WITH USE OF A STAMP OR SIMILAR INDICATION OF APPROVAL, DISAPPROVAL, ETC. SUCH LANGUAGE APPLIED TO MANUFACTURER'S DRAWINGS BY THE CUSTOMER, ARCHITECT, ENGINEER, OR ANY OTHER PARTY WILL BE CONSIDERED AS UNACCEPTABLE ALTERATIONS TO THESE DRAWING NOTES, AND WILL NOT ALTER THE CONTRACTUAL RIGHTS AND OBLIGATIONS EXISTING BETWEEN MANUFACTURER AND ITS CUSTOMER.

GENERAL NOTES

THE STRUCTURE UNDER THIS CONTRACT HAS BEEN DESIGNED AND DETAILED FOR THE LOADS AND CONDITIONS STIPULATED IN THE CONTRACT AND SHOWN ON THESE DRAWINGS. ANY ALTERATIONS TO THE STRUCTURAL SYSTEM OR REMOVAL OF ANY COMPONENT PARTS, OR THE ADDITION OF OTHER CONSTRUCTION MATERIALS OR LOADS MUST BE DONE UNDER THE ADVICE AND DIRECTION OF A REGISTERED ARCHITECT, CIVIL OR STRUCTURAL ENGINEER. METALLIC BUILDING COMPANY WILL ASSUME NO RESPONSIBILITY FOR ANY LOADS NOT INDICATED. THIS METAL BUILDING IS DESIGNED WITH METALLIC BUILDING COMPANY'S STANDARD PRACTICES WHICH ARE BASED ON PERTINENT PROCEDURES AND RECOMMENDATIONS OF THE FOLLOWING ORGANIZATIONS AND CODES.

- AMERICAN INSTITUTE OF STEEL CONSTRUCTION: "SPECIFICATION FOR THE DESIGN, FABRICATION AND ERECTION OF STRUCTURAL STEEL FOR BUILDINGS"
- AMERICAN IRON AND STEEL INSTITUTE: "SPECIFICATION FOR THE DESIGN OF COLD FORMED STEEL STRUCTURAL MEMBERS"
- AMERICAN WELDING SOCIETY: "STRUCTURAL WELDING CODE" AWS D1.1.
- METAL BUILDING MANUFACTURER'S ASSOCIATION: "LOW RISE BUILDING SYSTEMS MANUAL"
- INTERNATIONAL CONFERENCE OF BUILDING OFFICIALS: "UNIFORM BUILDING CODE"
- SOUTHERN BUILDING CODE CONGRESS INTERNATIONAL: "STANDARD BUILDING CODE"
- BUILDING OFFICIAL AND CODE ADMINISTRATORS INTERNATIONAL: "BOCA NATIONAL BUILDING CODE"
- NATIONAL BUILDING CODE OF CANADA.

MATERIAL PROPERTIES OF STEEL PLATE USED IN THE FABRICATION OF PRIMARY RIGID FRAMES, AND OTHER PRIMARY STRUCTURAL EXCLUSIVE OF COLD-FORMED SECTIONS, CONFORM TO ASTM-A529 OR A-572. FLANGES WITH THICKNESS OF ONE INCH OR LESS AND WIDTH OF 12" OR LESS CONFORM TO A-529 WITH A MINIMUM YIELD POINT OF 55,000 psi. FLANGES GREATER THAN 1" IN THICKNESS OR 12" IN WIDTH CONFORM TO A-572 WITH A MINIMUM YIELD POINT OF 50,000 psi. WEB MATERIAL CONFORMS TO ASTM-A36 MODIFIED WITH A MINIMUM YIELD POINT OF 46,000 psi. MATERIAL PROPERTIES OF PIPE SECTIONS CONFORM TO ASTM-A53 TYPE E, GRADE B WITH A MINIMUM YIELD POINT OF 35,000 psi.

MATERIAL PROPERTIES OF HOT ROLLED STEEL MEMBERS CONFORM TO THE REQUIREMENTS OF ASTM-A36 OR A572 WITH A MINIMUM YIELD POINT OF 50,000 psi.

MATERIAL PROPERTIES OF COLD FORMED LIGHT GAGE STEEL MEMBERS CONFORM TO ASTM-A570 OR A607 GRADE 55 MODIFIED WITH A MINIMUM YIELD POINT OF 57,000 psi.

MATERIAL PROPERTIES OF ROOF/WALL SHEETING, BASE METAL CONFORM TO ASTM-A792 GRADES D OR E WITH MINIMUM YIELD POINTS OF 50,000 psi AND 80,000 psi RESPECTIVELY, AS REQUIRED BY DESIGN. COATING OF BASE MATERIAL IS 55% ALUMINUM-ZINC ALLOY IN ACCORDANCE WITH A255 SPECIFICATIONS.

CABLE UTILIZED FOR BRACING CONFORMS TO ASTM A471.

ROD AND ANGLE UTILIZED FOR BRACING MEMBERS CONFORM TO ASTM A36. STRUCTURAL JOINTS WITH A.S.T.M. A-325 HIGH STRENGTH BOLTS, WHERE INDICATED ON THE DRAWINGS, SHALL BE ASSEMBLED AND THE FASTENERS TIGHTENED IN ACCORDANCE WITH "TURN-OF-NUT" METHOD AS DESCRIBED IN THE SPECIFICATION FOR STRUCTURAL JOINTS USING A.S.T.M. A-325 OR A-490 BOLTS (11-13-85), UNLESS OTHERWISE NOTED. ALL JOINTS WILL BE ASSEMBLED WITHOUT WASHERS UNLESS OTHERWISE NOTED.

ALL STEEL MEMBERS EXCEPT BOLTS, FASTENERS AND CABLE SHALL RECEIVE ONE SHOP COAT OF IRON OXIDE CORROSION INHIBITIVE PRIMER, MEETING THE PERFORMANCE REQUIREMENTS OF TTP-636. SHOP AND FIELD INSPECTIONS AND ASSOCIATED FEES ARE THE RESPONSIBILITY OF THE CONTRACTOR, UNLESS STIPULATED OTHERWISE IN THE CONTRACT.

METALLIC BUILDING COMPANY WILL IDENTIFY PRIMARY STRUCTURAL STEEL WITH A MINIMUM YIELD POINT GREATER THAN 36,000 PSI BY MEANS OF A STICKER NEAR THE ERECTION MARK ON EACH SHIPPED PIECE. SECONDARY MEMBERS WITH A YIELD POINT EQUAL TO OR GREATER THAN 33,000 PSI SHALL BE IDENTIFIED BY MEANS OF A STICKER NEAR THE ERECTION MARK ON EACH SHIPPED PIECE. (THIS IS IN ACCORDANCE TO THE 1997 UBC SECTION 2203.2 AND 2203.3.)

SAFETY COMMITMENT

METALLIC BUILDING COMPANY HAS A COMMITMENT TO MANUFACTURE QUALITY BUILDING COMPONENTS THAT CAN BE SAFELY ERECTED. HOWEVER, THE SAFETY COMMITMENT AND JOB SITE PRACTICES OF THE ERECTOR ARE BEYOND THE CONTROL OF METALLIC BUILDING COMPANY.

IT IS STRONGLY RECOMMENDED THAT SAFE WORKING CONDITIONS AND ACCIDENT PREVENTION PRACTICES BE THE TOP PRIORITY OF ANY JOB SITE.

LOCAL, STATE AND FEDERAL SAFETY AND HEALTH STANDARDS SHOULD ALWAYS BE FOLLOWED TO HELP INSURE WORKER SAFETY.

MAKE CERTAIN ALL EMPLOYEES KNOW THE SAFEST AND MOST PRODUCTIVE WAY OF ERECTING A BUILDING. EMERGENCY PROCEDURES SHOULD BE KNOWN TO ALL EMPLOYEES.

DAILY MEETINGS HIGHLIGHTING SAFETY PROCEDURES ARE ALSO RECOMMENDED. THE USE OF HARD HATS, RUBBER SOLE SHOES FOR ROOF WORK, PROPER EQUIPMENT FOR HANDLING MATERIAL, AND SAFETY NETS WHERE APPLICABLE, ARE RECOMMENDED.

RAIN FALL INTENSITY IS EQUAL TO 0.0 INCHES PER HOUR FOR A 5 MIN. DURATION (5 YEAR MEAN RECURRENCE).

BUILDING DESCRIPTION:

BUILDING DESCRIPTION:					ENDWALL FRAME TYPE	
BASIC SIZE:	WIDTH	LENGTH	HEIGHT	ROOF PITCH	LEFT	RIGHT
BLDG. "A"	CL 40'-0"	40'-0"	14'-0" E.H.	1:12 (RS)	BEARING FRAME	BEARING FRAME
WARNING: IN NO CASE SHOULD GALVALUME STEEL PANELS BE USED IN CONJUNCTION WITH LEAD OR COPPER. BOTH LEAD AND COPPER HAVE HARMFUL CORROSION EFFECTS ON THE ALUMINUM ZINC ALLOY COATING WHEN THEY ARE USED IN CONTACT WITH GALVALUME STEEL PANELS. EVEN RUN-OFF FROM COPPER FLASHING, WIRING, OR TUBING ONTO GALVALUME SHOULD BE AVOIDED.						
BASE CONDITION:		SHEETING:		BLANKET TYPE INSULATION:		
NO SHEETING RECESS	26 G	"R" PANEL GALVALUME PLUS	ROOF	NONE <input type="checkbox"/> BY MANUFACTURER <input type="checkbox"/> BY OTHERS <input checked="" type="checkbox"/>	WALL <input type="checkbox"/> UL-25 <input type="checkbox"/>	
W/BASE ANGLE	26 G	"R" PANEL CHARCOAL GRAY	WALL	SELF DRILLING SCREWS * ZINC CAPPED		
TAPE SEAL:		TRIM: (1/8" POP RIVETS AT SPICES)		MEMBER ROOF (# 12 x 1/4 SDS)	STITCH ROOF (# 14 x 3/8 LPK)	ANCHOR BOLTS BY OTHERS <input checked="" type="checkbox"/>
3/8" <input checked="" type="checkbox"/>	26 G	POLAR WHITE	RAKE	MEMBER WALL (# 12 x 1/4 SDS)	STITCH WALL (# 14 x 3/8 LPK)	
1" <input type="checkbox"/>	26 G	POLAR WHITE	EAVE	RAKE TO ROOF: STITCH	RAKE TO WALL: STITCH	
WARRANTIES		26 G	POLAR WHITE	GUTTER	GUTTER TO ROOF: STITCH	GUTTER STRAPS: STITCH
U.L. 90	NO	26 G	POLAR WHITE	DOWNSP.	CORNER TRIM: STITCH	RAKE ANGLE: MEMBER
20 YR ROOF	YES	26 G	CHARCOAL GRAY	CORNER	ADDITIONAL FEATURES:	
20 YR WALL	YES	26 G	POLAR WHITE	ACCESS.		

BUILDING LOADS

THIS IS TO CERTIFY THAT THIS STRUCTURE IS DESIGNED UTILIZING THE LOADS INDICATED AND APPLIED AS REQUIRED BY NC-1996

THIS CERTIFICATION IS LIMITED TO THE STRUCTURAL DESIGN OF THE FRAMING AND COVERING PARTS MANUFACTURED BY THE BUILDING MANUFACTURER AND AS SPECIFIED IN THE CONTRACT. ACCESSORY ITEMS SUCH AS DOORS, WINDOWS, LOUVERS, TRANSLUCENT PANELS, VENTILATORS ARE NOT INCLUDED. ALSO EXCLUDED ARE OTHER PARTS OF THE PROJECT NOT PROVIDED BY THE BUILDING MANUFACTURER SUCH AS FOUNDATIONS, MASONRY WALLS, MECHANICAL EQUIPMENT AND THE ERECTION AND INSPECTION OF THE BUILDING. THE BUILDING SHOULD BE ERECTED ON A PROPERLY DESIGNED FOUNDATION IN ACCORDANCE WITH THE BUILDING MANUFACTURER'S DESIGN MANUAL, THE ATTACHED DRAWINGS, AND GOOD ERECTION PRACTICES.

THE CONTRACTOR AND/OR ENGINEER OF RECORD IS TO CONFIRM THAT THESE LOADS COMPLY WITH REQUIREMENTS OF THE LOCAL BUILDING DEPT.

ROOF DEAD LOAD 2.0 PSF (FOR ROOF PANELS AND PURLINS)

COLLATERAL DEAD LOAD - PSF

ROOF LIVE LOAD

PRIMARY FRAMING 12 PSF

SECONDARY FRAMING 20 PSF

AUXILIARY LIVE LOAD - PSF

GROUND SNOW LOAD - PSF (C_e = -)

ROOF SNOW LOAD - PSF

WIND LOAD 80 MPH, EXPOSURE C

SEISMIC ZONE 1, A_s = 0.075, A_v = 0.075

Seismic Hazard Exposure Group 1

Seismic Performance Category B

Site Coefficient 2.0

Basic Structural System - Dual system with ordinary

moment frames of steel & concentrically braced frames

Response Modification Factor (R) 4.5

Deflection Amplification Factor (Cd) 4.0

Analysis Procedure - Equivalent Lateral Force

MEZZANINE LOADS

LIVE LOAD N/A PSF DEAD LOAD N/A PSF

CRANE INFORMATION N/A

DRAWING INDEX

ISSUE	PAGE	DESCRIPTION
0	C1 of 1	COVER SHEET
0	F1 of 1	ANCHOR BOLT PLAN & BASE B DETAILS AND REACTIONS
0	E1 of 3	ROOF FRAMING PLAN
0	E2 of 3	SIDEWALL FRAMING
0	E2 of 3	SIDEWALL SHEETING
0	E2 of 3	ENDWALL FRAMING
0	E2 of 3	ENDWALL SHEETING
0	E1 of 3	FRAME CROSS SECTION
0	E3 of 3	GENERAL DETAILS
0	S-1	STANDARD DETAILS
0	S-2	STANDARD DETAILS

NOTE: THE UNDERSIGNED IS NOT THE ENGINEER OF RECORD FOR THE OVERALL PROJECT.

DSN1 APR 3 15



DRAWING STATUS		REVISIONS				DESCRIPTION	
NO.	DATE	DESCRIPTION	BY	CK'D	DESCRIPTION	DATE	
A	2-25-02	FOR PERMIT	LFC	AMV			
0	3-14-02	FOR CONSTRUCTION	LFC	AMV			

<input type="checkbox"/> FOR APPROVAL: THESE DRAWINGS, BEING FOR APPROVAL, ARE BY DEFINITION NOT FINAL AND ARE FOR CONCEPTUAL REPRESENTATION ONLY. THEIR PURPOSE IS TO OBTAIN PROPER INTERPRETATION OF THE PROJECT DOCUMENTS. ALL DRAWINGS ISSUED "FOR CONSTRUCTION" CAN BE CONSIDERED AS COMPLETE.		<input type="checkbox"/> FOR PERMIT: THESE DRAWINGS, BEING FOR PERMIT, ARE BY DEFINITION NOT FINAL IN THIS STATE. AS A MINIMUM, PIECE MARKINGS ARE NOT IDENTIFIED. ONLY DRAWINGS ISSUED "FOR CONSTRUCTION" CAN BE CONSIDERED AS COMPLETE.	
<input checked="" type="checkbox"/> FOR CONSTRUCTION: THESE DRAWINGS, BEING FOR CONSTRUCTION, ARE BY DEFINITION FINAL DRAWINGS.			

METALLIC metallic building company 7301 FAIRVIEW • HOUSTON, TEXAS • P.O. BOX 40338 ZIP 77041 (713) 466-7788 ZIP 77240		DESCRIPTION COVER SHEET SIZE SEE BUILDING DESCRIPTION ABOVE CUSTOMER CAROLINA METAL STRUCTURES LOCATION ANCIEN, NC DRN. BY CK'D BY DATE SCALE JOB NO. PH BLDG. DESC. SHEET NO. ISSUE NONE 0605-199945 A C1 of 1 0	
--	--	--	--

MAR 18 2002

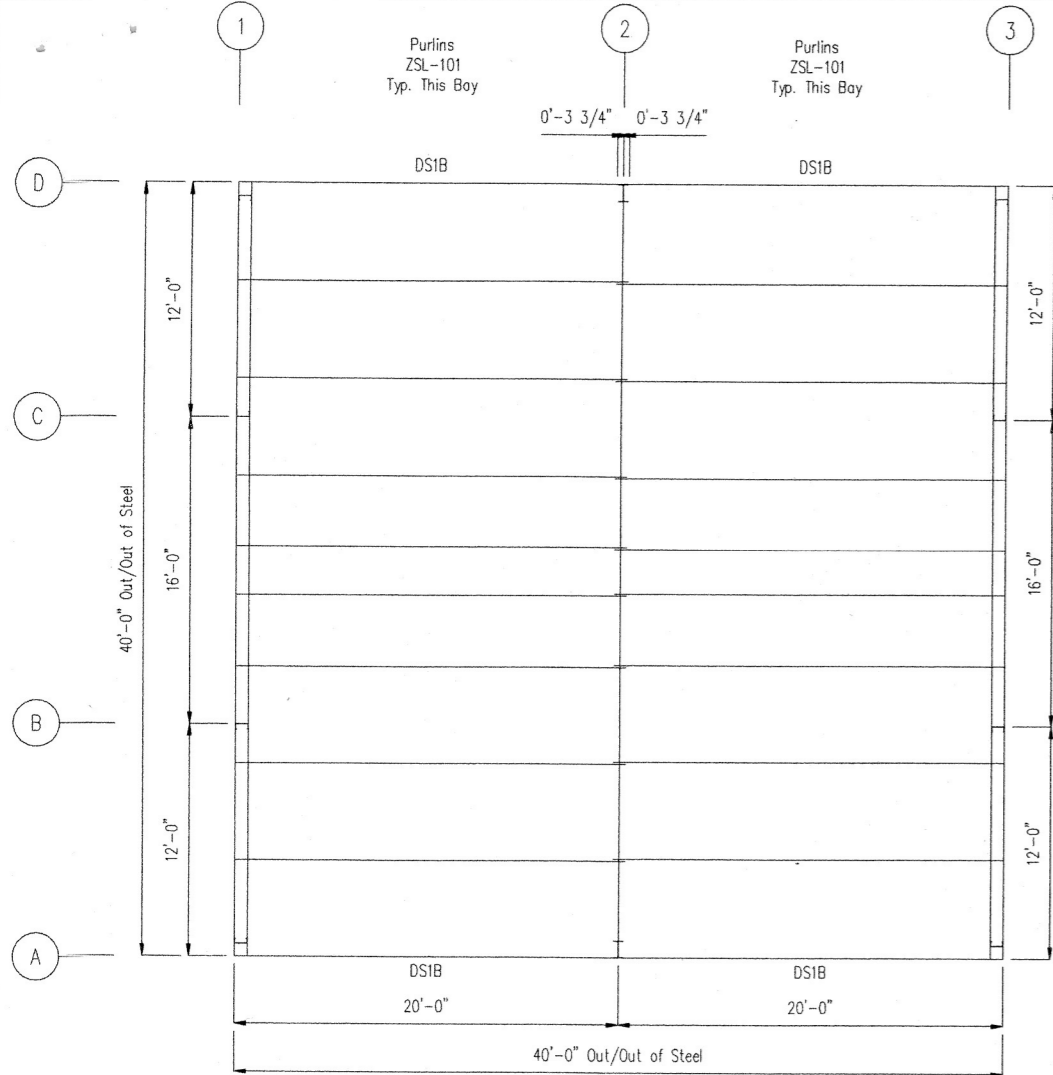

Roof Framing Plan (N.T.S)

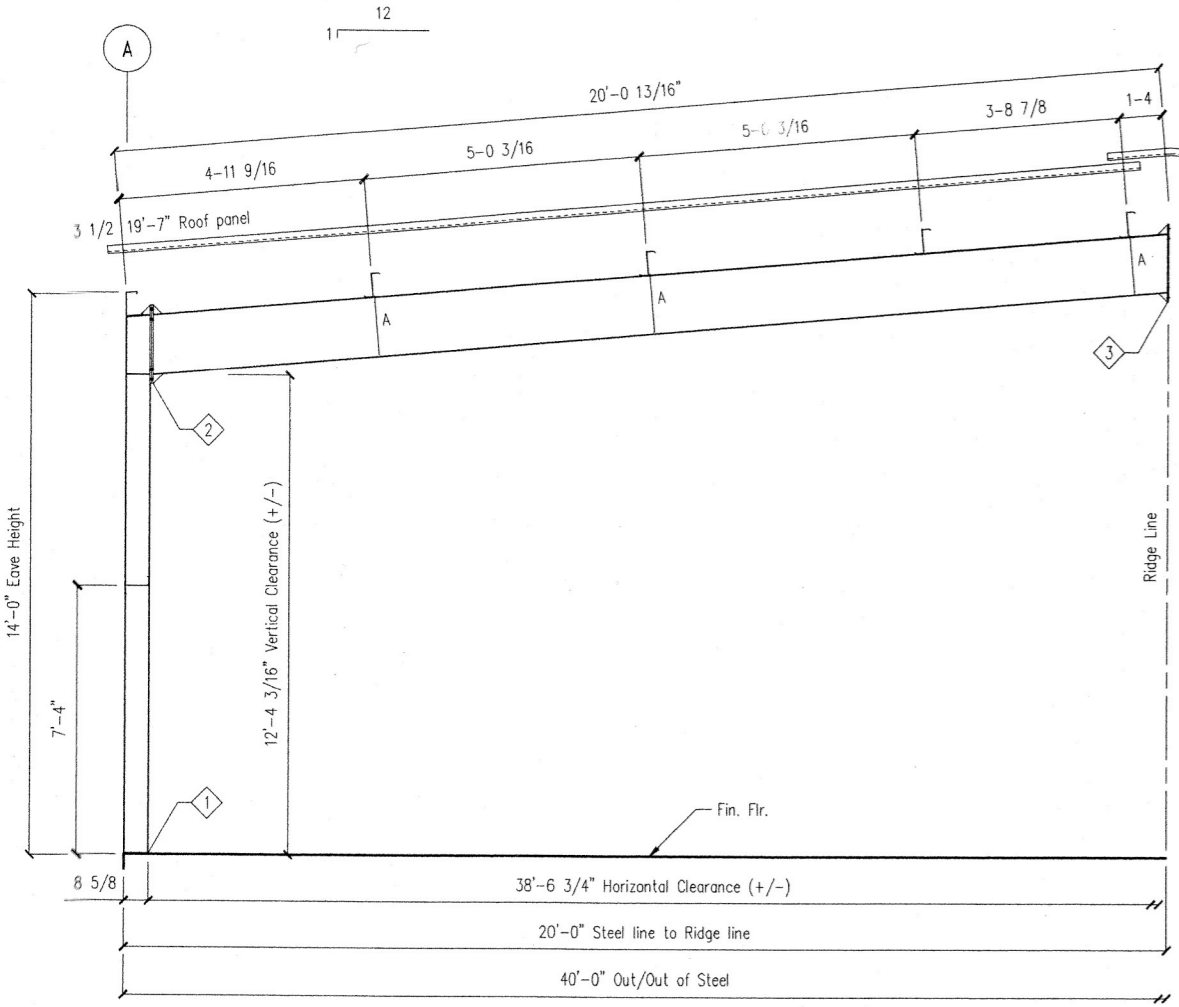

Connection Schedule	
Mark	Bolt Qty & Size
①	(4) 5/8 Dia. Anchor Bolts
②	(8) 3/4" x 2" A325
③	(8) 3/4" x 2" A325
Column Mark: XC-5134	
Rafter Mark: XR-5031	
Flange Braces	
A = FB-3100	

Typical Frame Cross Section (N.T.S)



Revisions			
No	Date	Description	By
A	2-25-02	FOR PERMIT	LFC/JMV
B	3-14-02	FOR CONSTRUCTION	LFC/JMV

Description		Erection Drawings	
Size		40'-0" x 40'-0" x 14'-0"	
Customer		CAROLINA METAL STRUCTURES	
Location		Raleigh, NC	
Dwg By	Chk By	Date	Scale
		2/25/02	NTS
Job No		0605-199945	
Sheet No		E1 of 3	

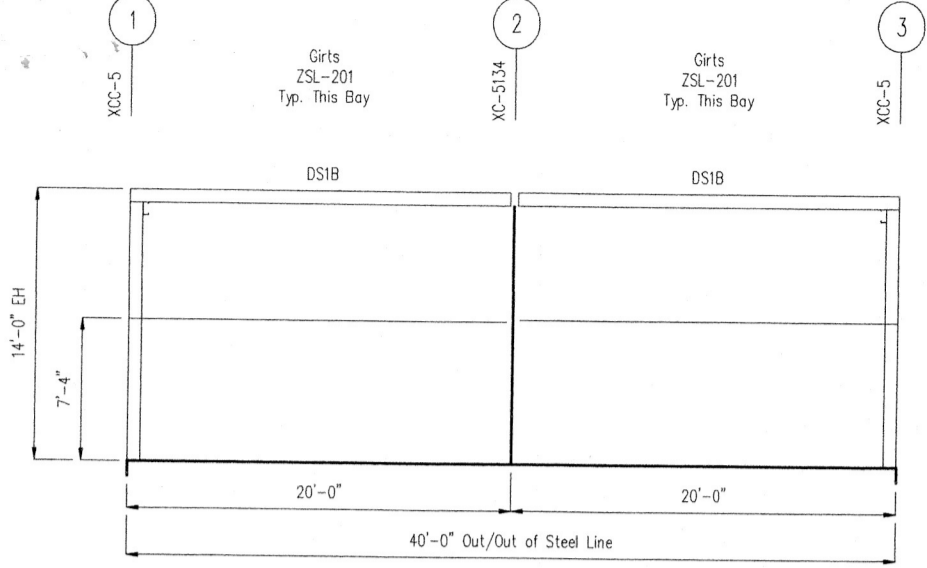

Sidewall Framing At Line "A" (N.T.S)

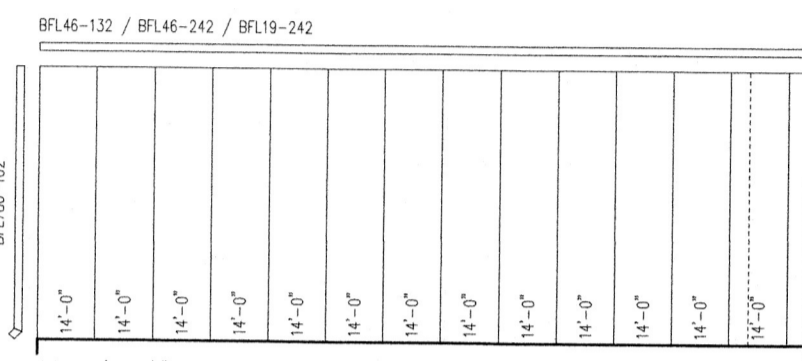

Sidewall Sheeting At Line "A" (N.T.S)

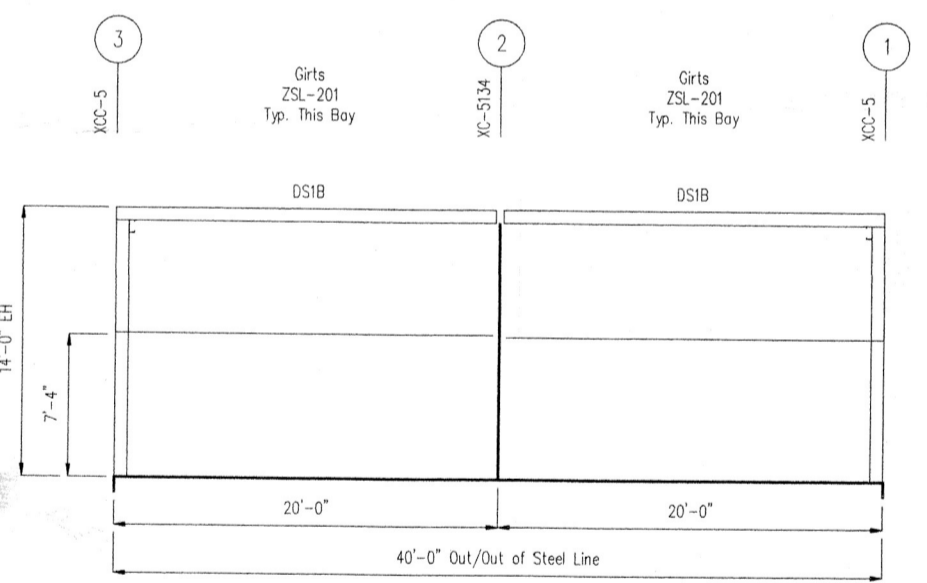

Sidewall Framing At Line "D" (N.T.S)

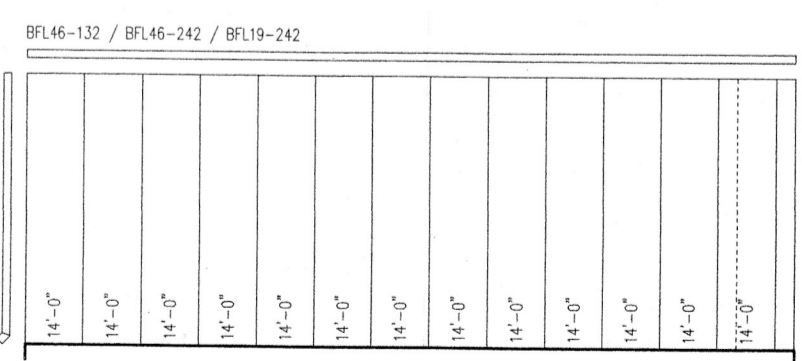

Sidewall Sheeting At Line "D" (N.T.S)

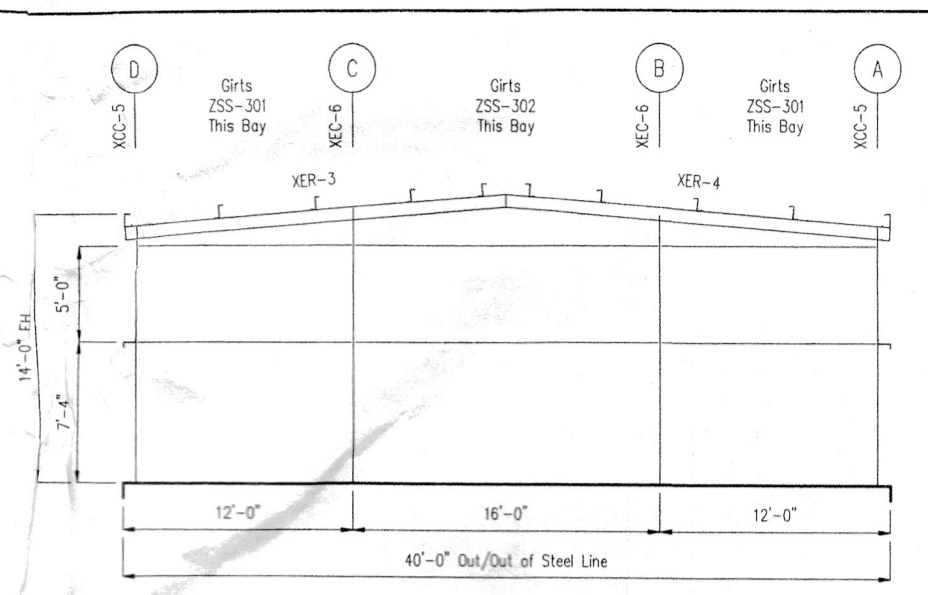

Endwall Framing At Line "1" (N.T.S)

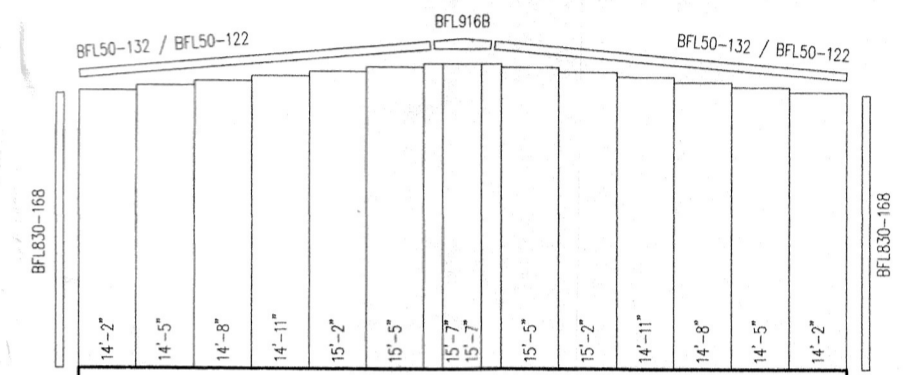

Endwall Sheeting At Line "1" (N.T.S)

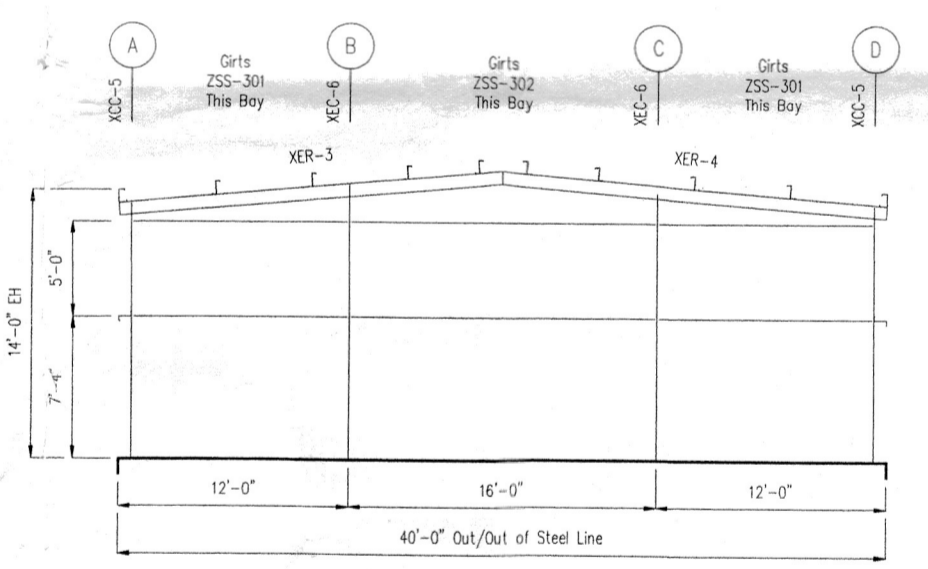

Endwall Framing At Line "3" (N.T.S)

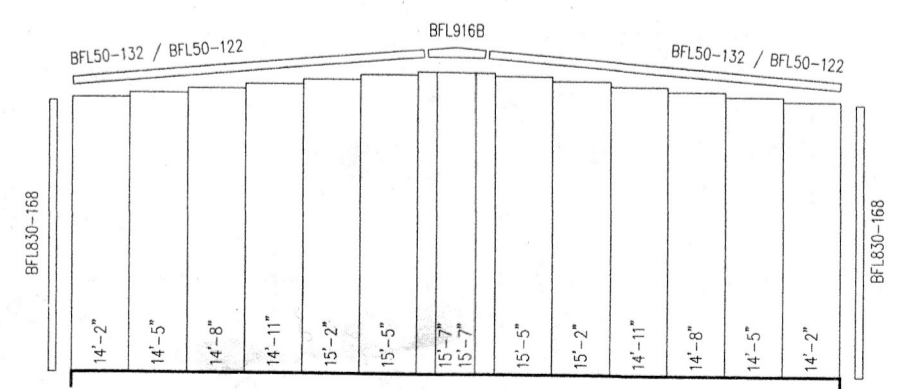

Endwall Sheeting At Line "3" (N.T.S)

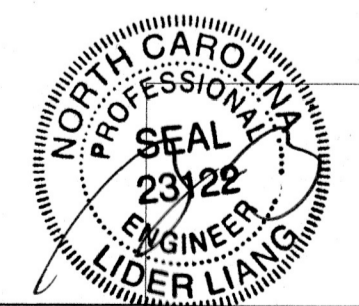

Revisions		Description		By		Chk	
No.	Date	Description	By	Chk	UFC	AMV	
A	2-25-02	FOR PERMIT	UFC	AMV			
B	3-14-02	FOR CONSTRUCTION	UFC	AMV			

Description		Erection Drawings	
Size	40'-0" x 40'-0" x 14'-0"	14'-0" x 14'-0" x 14'-0"	14'-0" x 14'-0" x 14'-0"
Customer	CAROLINA METAL BUILDINGS		
Location	CAROLINA METAL BUILDINGS		
Dwg By	Chk By	Date	Scale
		2/25/02	N.T.S.
Job No.		Sheet No.	
0605-199945		E2 of 3	

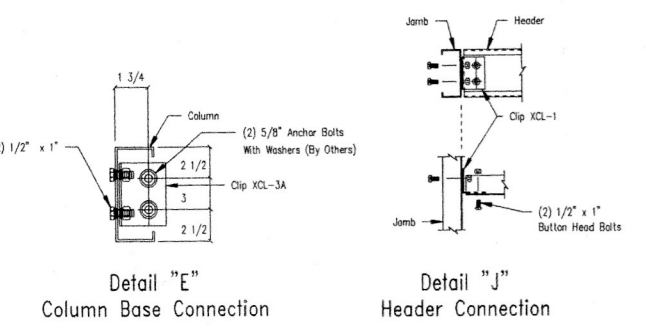
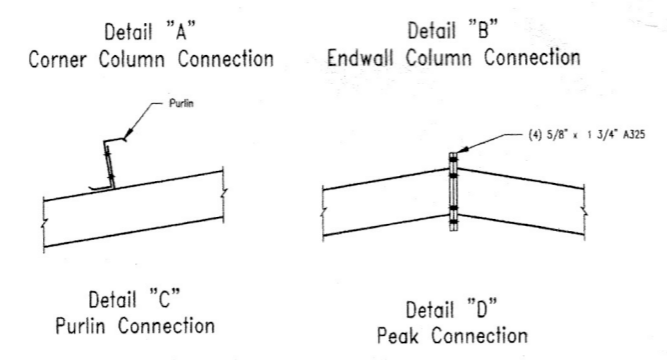
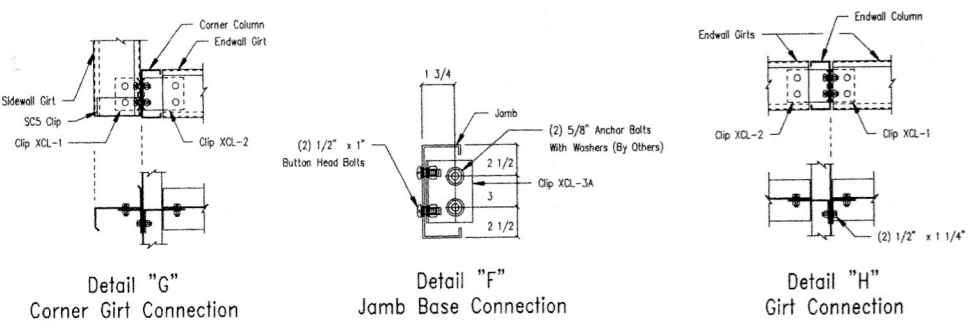
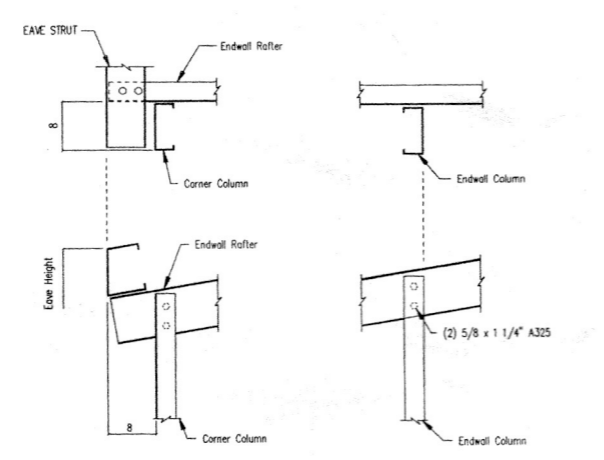
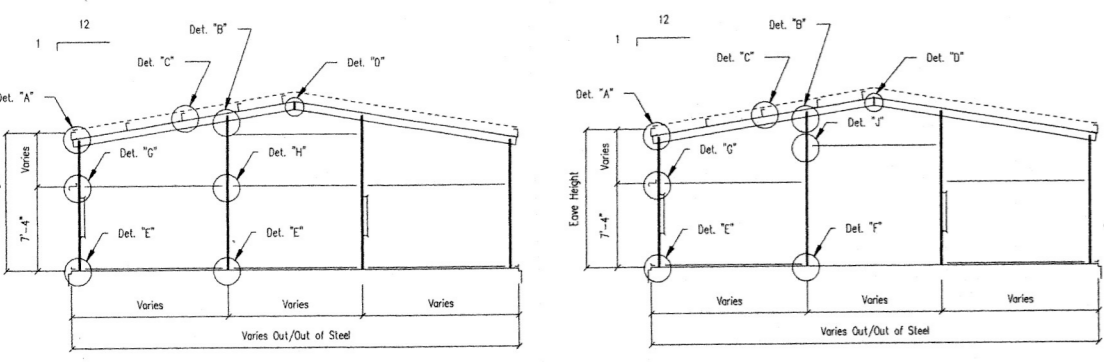

Note:
 Field attach header to jamb with (2) 1/2" bolts or (4) #12 screws at each end.
 All erection bolts are 1/2" x 1" CAD. Plated machine bolts U.N.

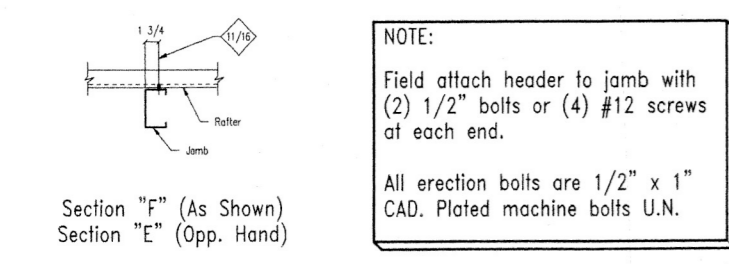
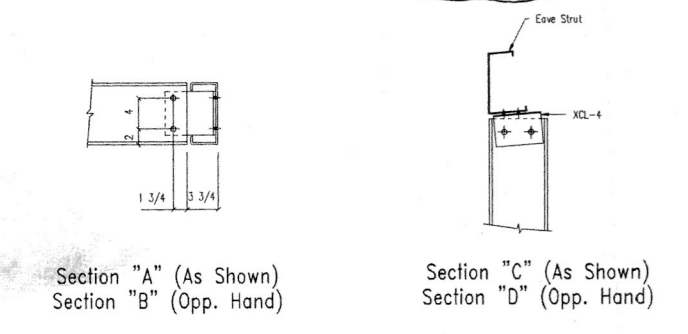
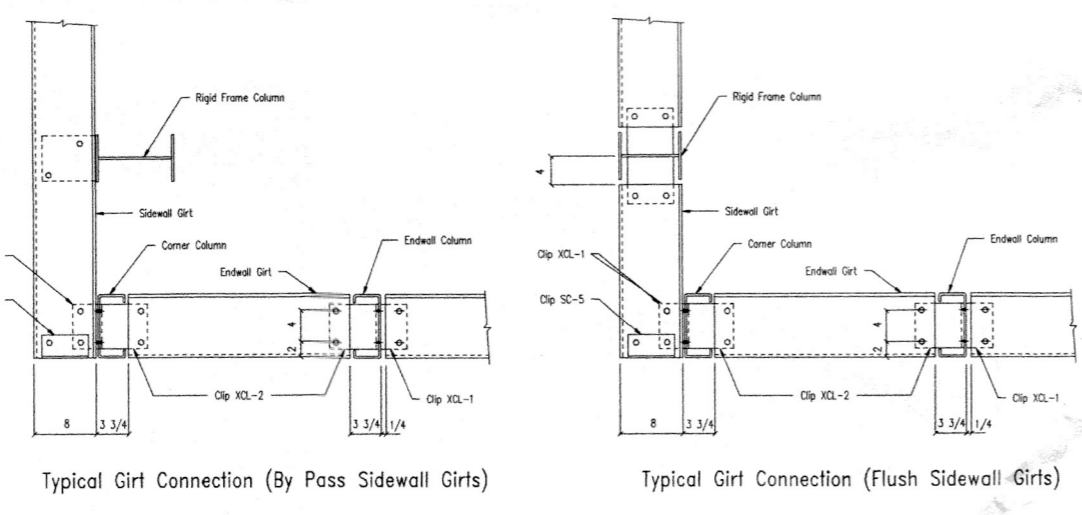
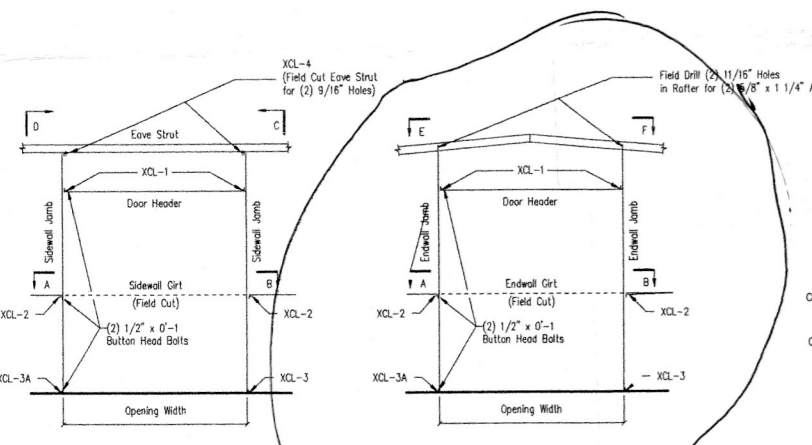

NOTE:
 Field attach header to jamb with (2) 1/2" bolts or (4) #12 screws at each end.
 All erection bolts are 1/2" x 1" CAD. Plated machine bolts U.N.

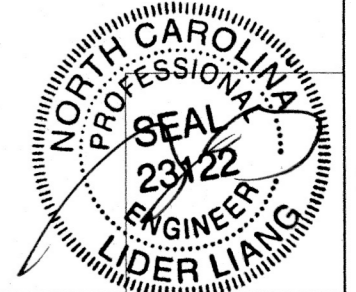

Revisions			
No.	Date	Description	By
A	2-25-02	FOR PERMIT	LFC/AMV
B	3-14-02	FOR CONSTRUCTION	LFC/AMV

Description		Standard Sections & Details	
Size		40'-0" x 40'-0" x 14'-0" LL: 13'-0" 96-85 W.C. 80 mph	
Customer		CAROLINA METAL STRUCTURES	
Location		WELLSVILLE	
Dwg. By	CHK. By	Date	Scale
		2/25/02	N.T.S.
Job No.		Sheet No.	
63580002*53303		E3 of 3	
Release 4c-3 (Jan 22, 2002)		0605-199945	

MAR 18 2002

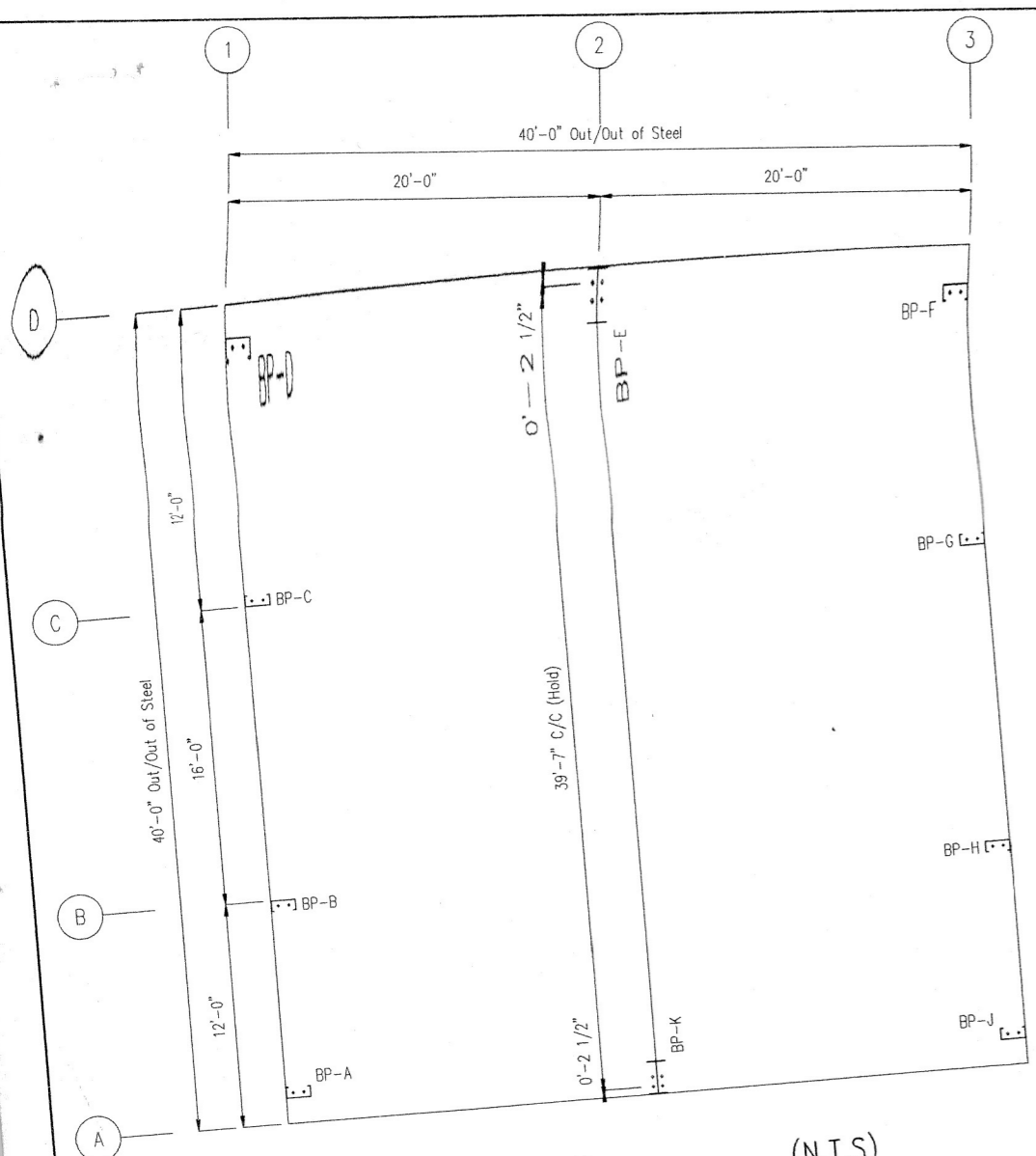

Anchor Bolt Setting Plan (N.T.S.)

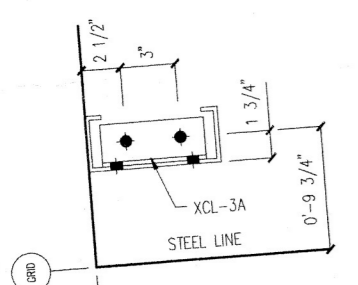

Detail "BP-A" (2) 5/8" AB

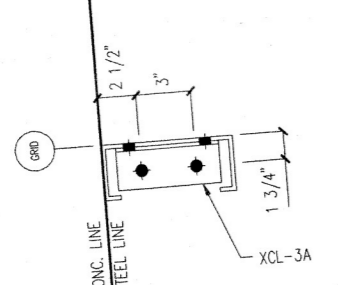

Detail "BP-B" (2) 5/8" AB

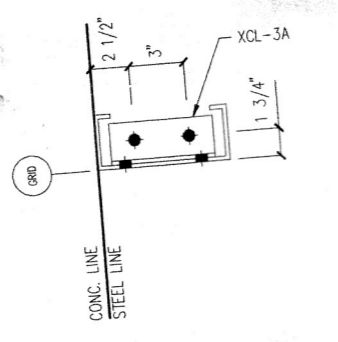

Detail "BP-C" (2) 5/8" AB

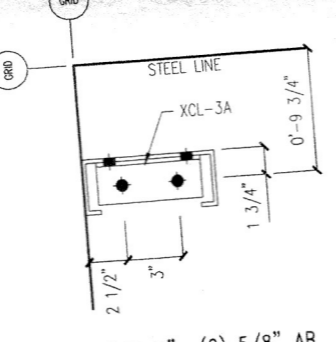

Detail "BP-D" (2) 5/8" AB

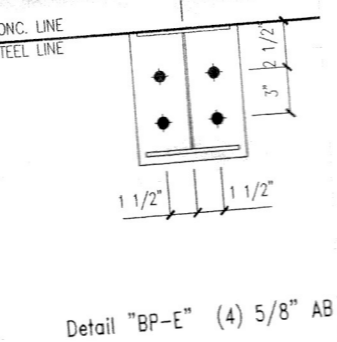

Detail "BP-E" (4) 5/8" AB

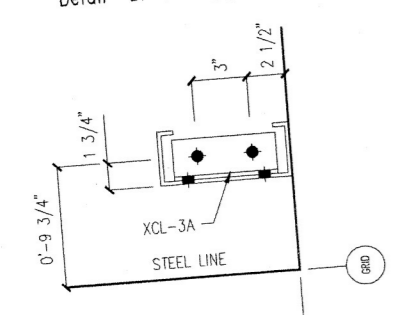

Detail "BP-F" (2) 5/8" AB

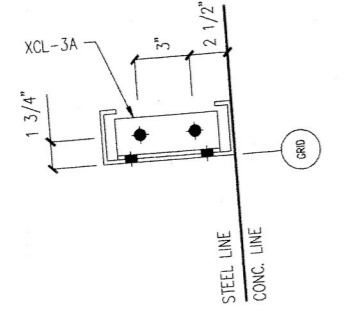

Detail "BP-G" (2) 5/8" AB

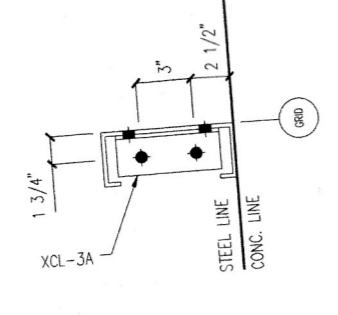

Detail "BP-H" (2) 5/8" AB

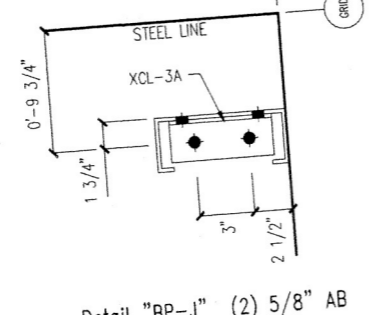

Detail "BP-J" (2) 5/8" AB

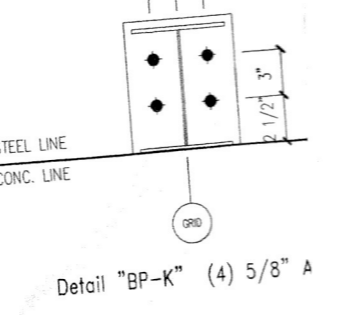

Detail "BP-K" (4) 5/8" AB

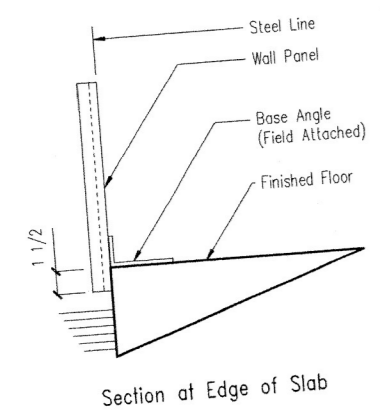

Section at Edge of Slab

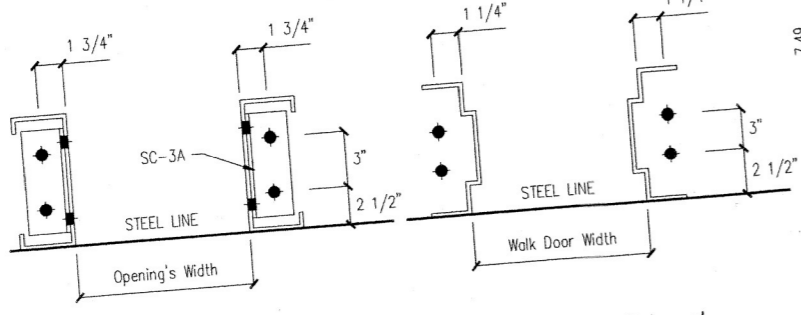

Framed Opening AB Layout

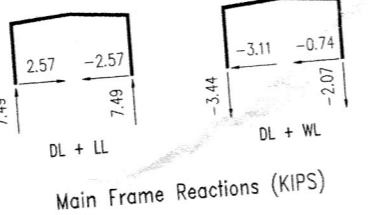

Walk Door AB Layout

Main Frame Reactions (KIPS)

		Revisions					
		No.	Date	Description	By	Chk.	
		0	2-25-02	FOR CONSTRUCTION	LFC	AMV	

Anchor Bolt Projections	DIA.	PROJ.	No.	Date	Description	By	Chk.
1/2"	1 1/2"	2"					
5/8"	2"	2"					
3/4"	2 1/2"	2"					
7/8"	3 1/2"	2"					
1"	3 1/2"	2"					
1 1/8"	3 1/2"	2"					
1 1/4"	4"	2"					
1 1/2"	5"	2"					

Anchor Bolt Projections		Revisions		Customer		Location	
Description	Anchor Bolt Plan, Details & Reactions	By	Chk.	Customer	CAROLINA METAL STRUCTURES	Location	Waco, TX
Size	40'-0" x 40'-0" x 14'-0"	Date	2/25/02	Scale	NTS	Sheet No.	0605-199945
Issue	18 2002	Release	4c-3 (Jan 22, 2002)	Issue	F1 of 1		



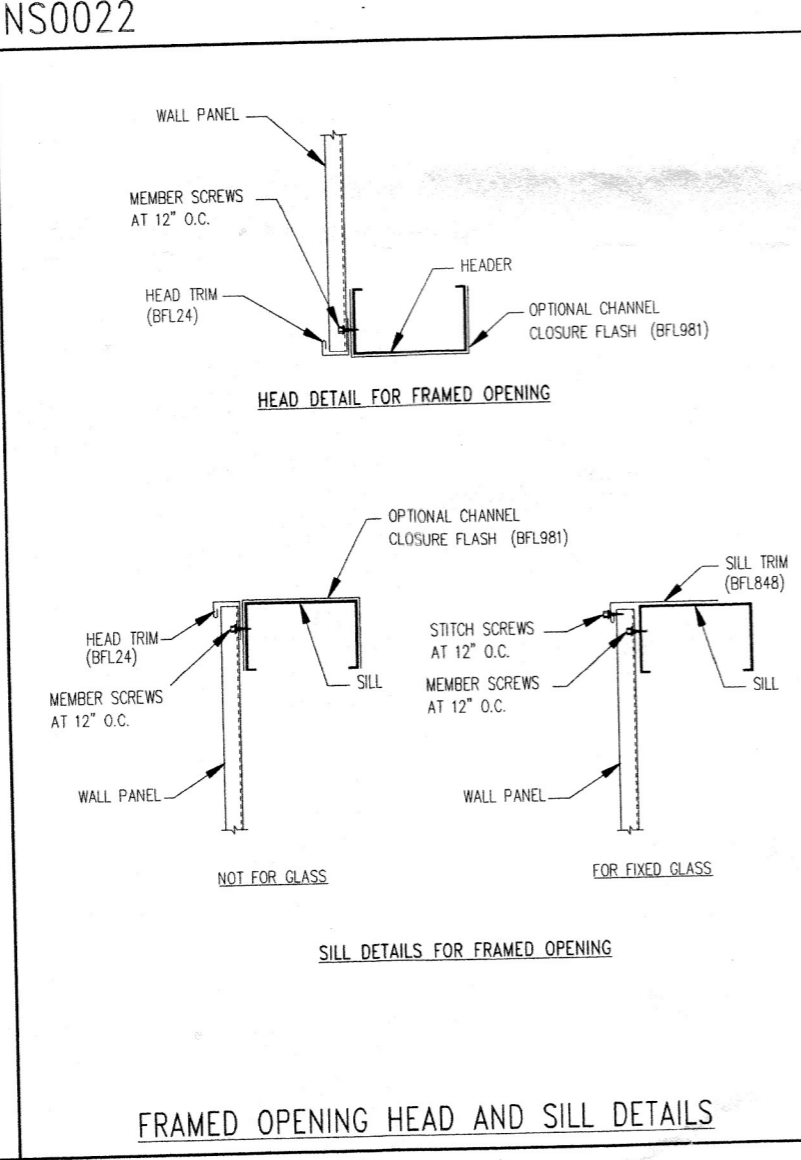
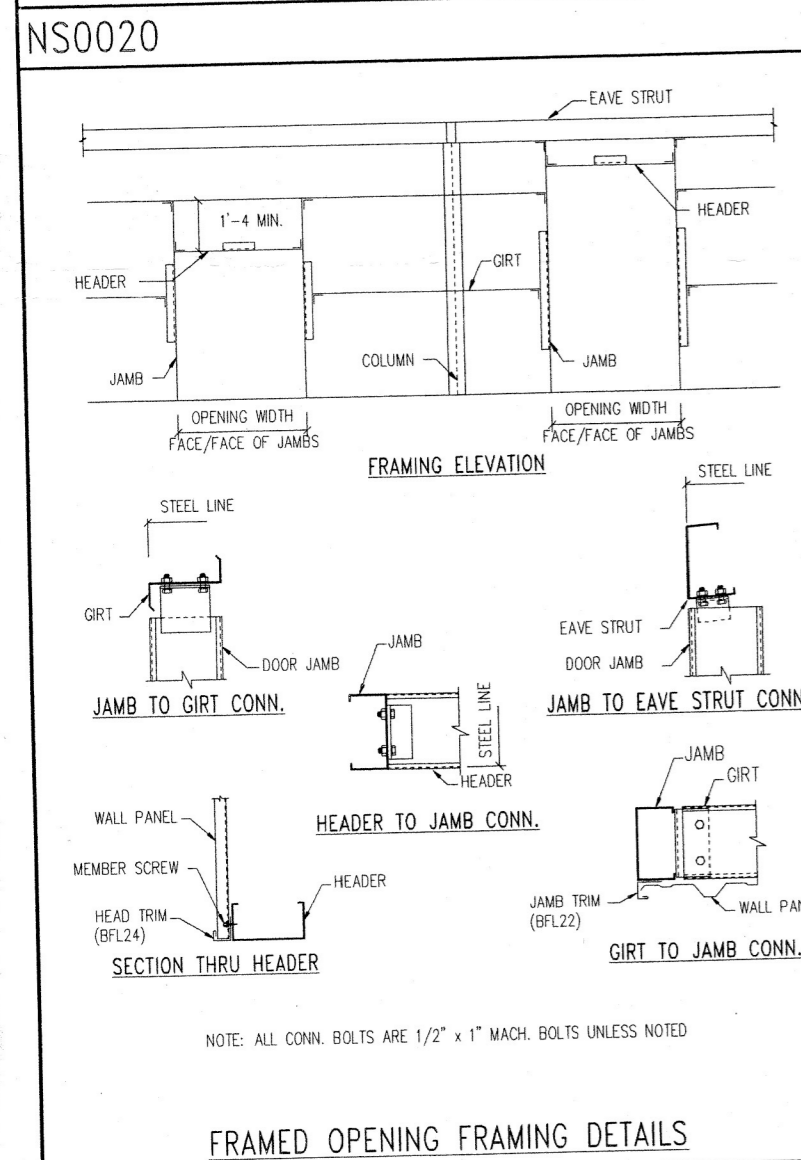
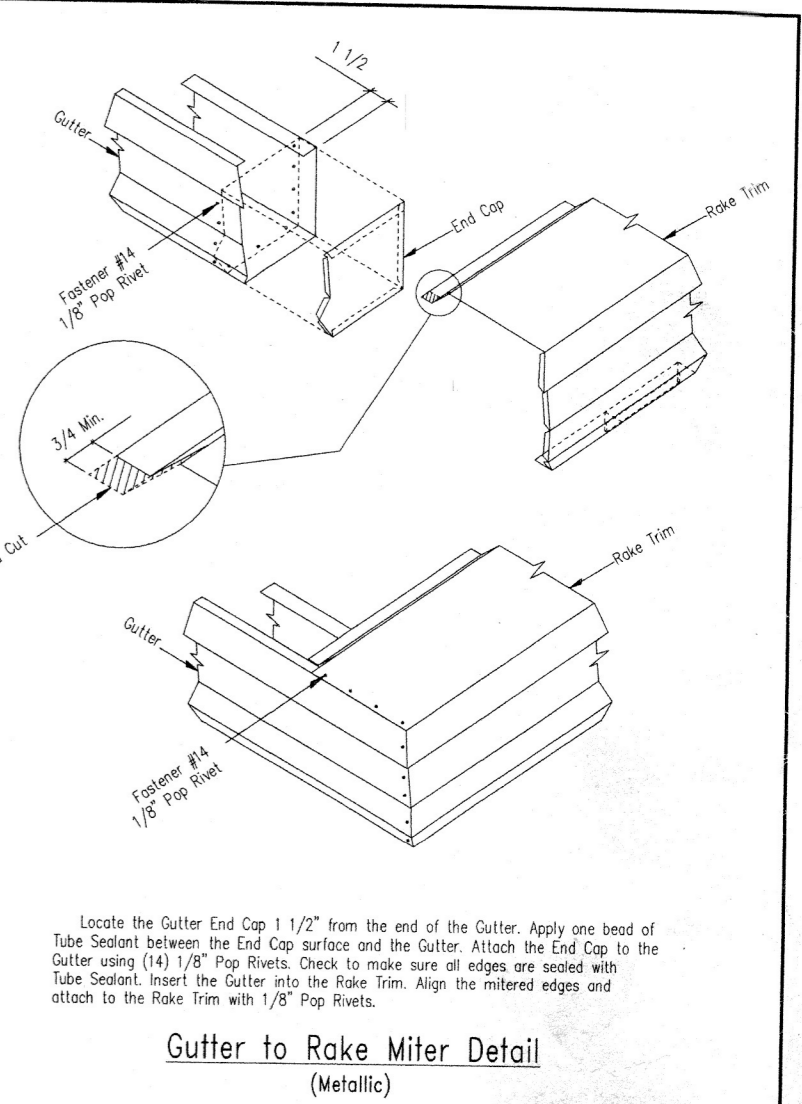
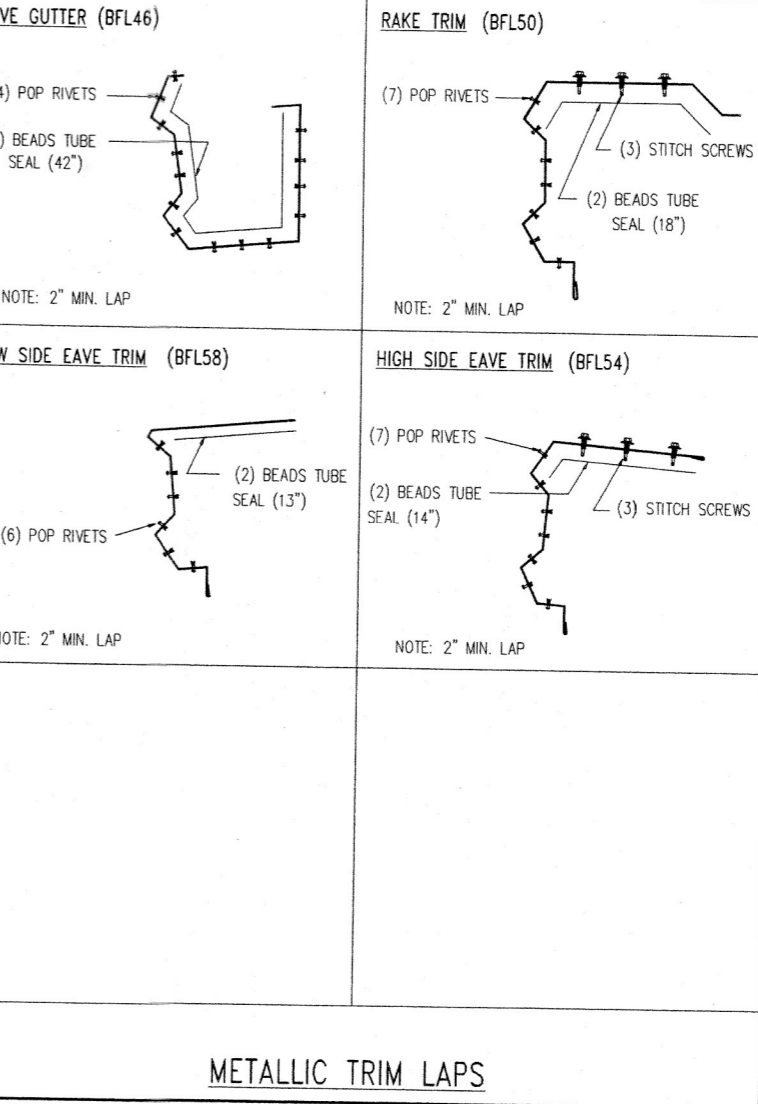
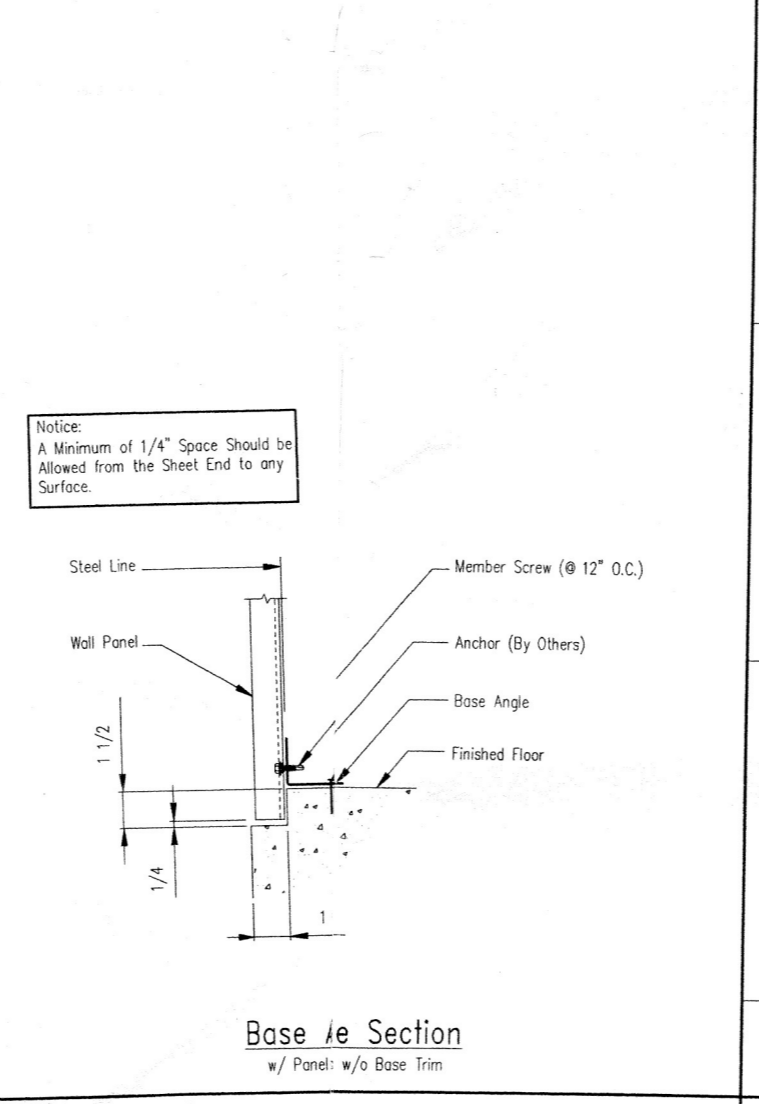
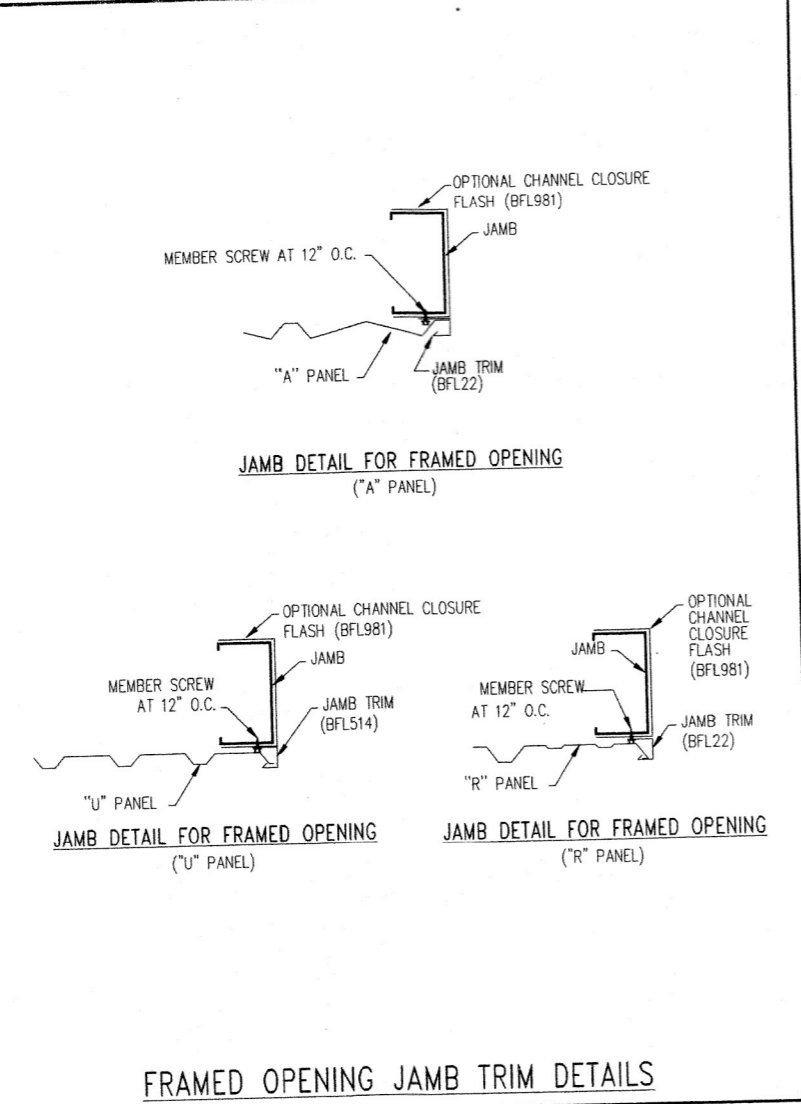
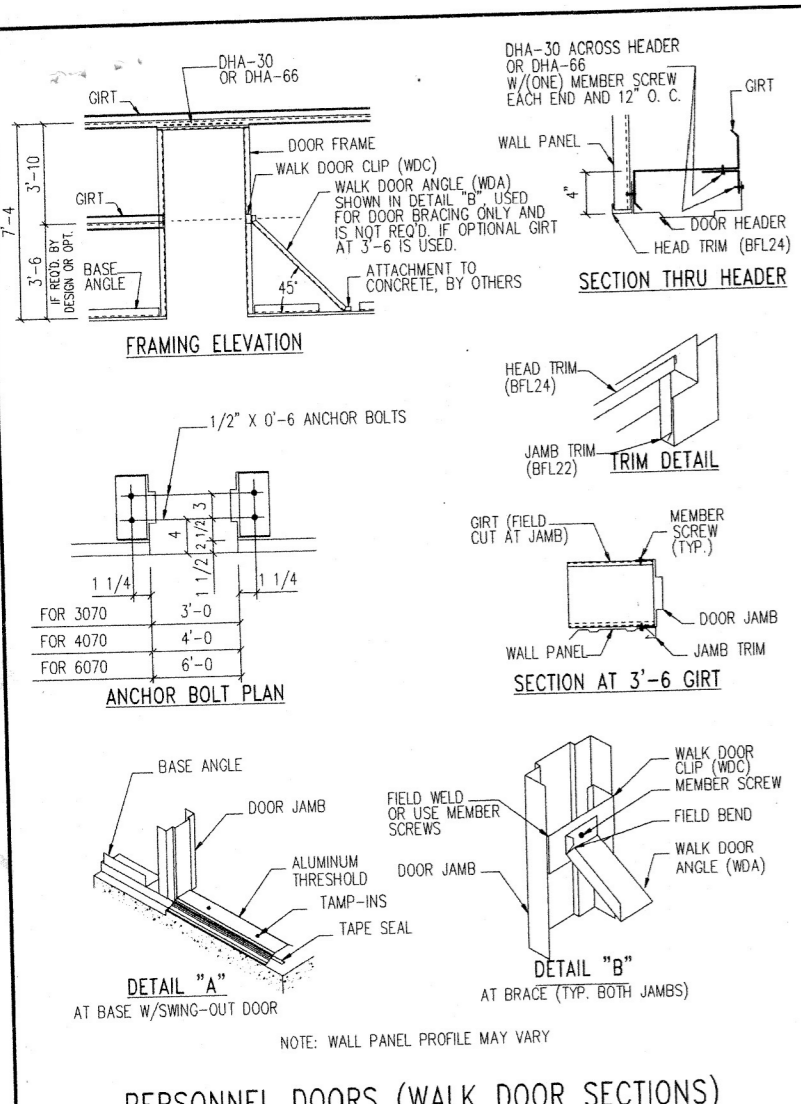

NS0062H

Cold Formed Steel Compon Yield Strength = 57.0 K.S.I. (Typ.)

Section Name	Dimensions			Member Properties			Shape	
	U	B1	B2	Lip Area	I _x	I _y		S _x eff
8 Z 16	8	2 1/2	2 1/2	.911,822	9.177	1.081	1.747	Z
8 Z 14	8	2 1/2	2 1/2	.930,976	9.177	1.289	2.137	
8 Z 13	8	2 1/2	2 1/2	.956,185	11.095	1.577	2.724	
8 Z 12	8	2 1/2	2 1/2	.990,463	13.624	1.967	3.347	
10 x 2 Z 14	10	2 1/2	2 1/2	.930,116	15.642	1.290	2.858	Zees
10 x 2 Z 13	10	2 1/2	2 1/2	.958,355	18.933	1.578	3.727	
10 x 2 Z 12	10	2 1/2	2 1/2	.990,673	23.285	1.968	4.586	
10 x 3 Z 14	10	3 1/2	3 1/2	.990,256	19.094	3.077	2.907	
10 x 3 Z 13	10	3 1/2	3 1/2	.951,525	23.112	3.759	3.933	Cees
10 x 3 Z 12	10	3 1/2	3 1/2	.991,853	28.427	4.681	4.932	
12 Z 14	12	3 1/2	3 1/2	.931,398	29.321	3.078	3.470	
12 Z 13	12	3 1/2	3 1/2	.951,695	35.515	3.760	4.733	
12 Z 12	12	3 1/2	3 1/2	.992,093	43.722	4.682	6.374	Eave Struts
8 x 2 1/2 C 16	8	2 1/2	2 1/2	.771,822	7.791	0.675	1.668	
8 x 2 1/2 C 14	8	2 1/2	2 1/2	.803,976	9.210	0.800	2.049	
8 x 2 1/2 C 12	8	2 1/2	2 1/2	.861,463	13.649	1.196	3.412	
8 x 3 1/2 C 16	8	3 1/2	3 1/2	.771,940	9.652	1.523	1.712	Cees
8 x 3 1/2 C 14	8	3 1/2	3 1/2	.811,116	11.411	1.808	2.251	
8 x 3 1/2 C 12	8	3 1/2	3 1/2	.861,673	16.921	2.712	3.574	
10 x 3 1/2 C 12	10	3 1/2	3 1/2	.861,883	28.456	2.912	4.861	
12 x 3 1/2 C 12	12	3 1/2	3 1/2	.82,093	43.758	3.071	6.293	Eave Struts
8 E.S. 16	8	3 1/2	5	1.1,058	10.936	2.902	1.890	
8 E.S. 14	8	3 1/2	5	1.1,256	12.924	3.440	2.499	
8 E.S. 12	8	3 1/2	5	1.1,883	19.143	5.142	4.001	
10 E.S. 14	10	3 1/2	5	1.1,396	21.670	3.697	3.161	Eave Struts
10 E.S. 12	10	3 1/2	5	1.2,093	32.195	5.537	5.458	
12 E.S. 14	12	3 1/2	5	1.1,536	33.201	3.907	3.815	
12 E.S. 12	12	3 1/2	5	1.2,303	49.422	5.855	7.067	

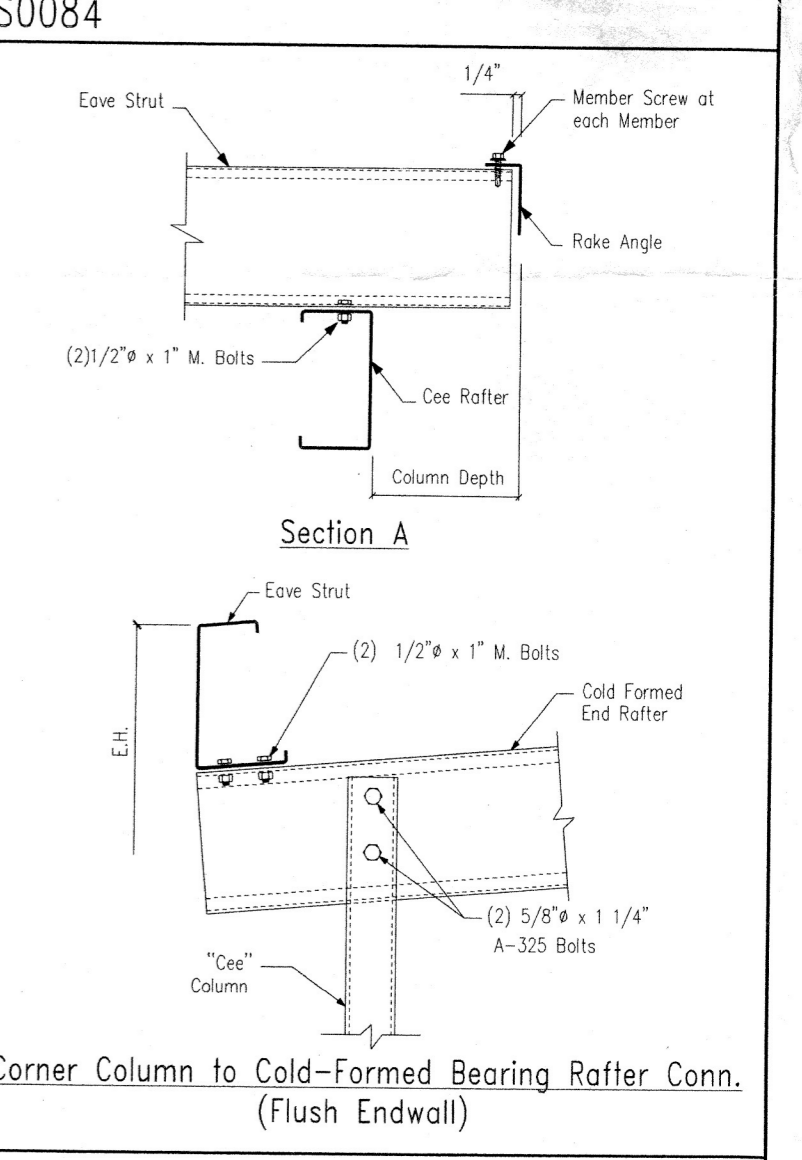
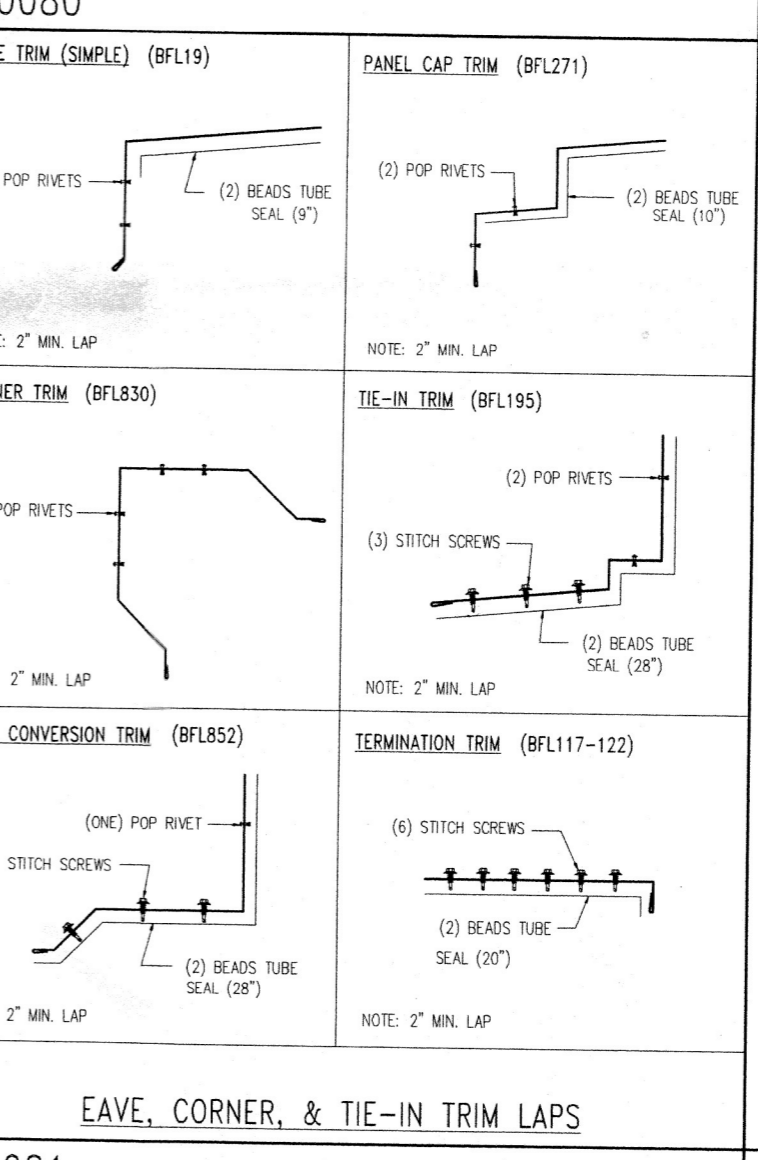

NS0021

NOTE:
1. These drawings are intended to depict general installation of item(s) described above. Some item(s) may have been omitted for clarity of presentation. Consult your erection manual or additional S-Sheets for further guidelines and/or clarifications.

NS0022

NS0067

NS0081

REVISIONS			
NO.	DATE	DESCRIPTION	BY
A	02-25-02	FOR PERMIT	LFC
0	03-14-02	FOR CONSTRUCTION	AMV

NS0242

Standard Details

Customer: CAROLINA METAL STRUCTURES
 End User: ANTHONY AYDT
 Location: MONCURE, NC

Det. By	Chk By	Date	Scale	Building ID	Job Number	Sheet Number	Issue
		02-25-02	N.T.S.		0605-199945	S-2	0