



JS CONSULTING & DESIGN
ENGINEERING AND CONSULTING
11703 DURANT RD
RALEIGH, NC 27614
P (919) 675-1680
F (919) 324-3681

CERTIFICATE NUMBER: P-1513

Client:

Luna Metal Buildings and Concrete
904 N Fayetteville St
Asheboro, NC 27203
(o) 336-628-0273

Project:

30'x48'x12' w/ 12'x30'x8' lean to
Joel Lynn
5126 Spring Hill Church Rd
Lillington, NC 27546

Job No:

2001-229R
Date:
03/03/20
Sheet:
S1

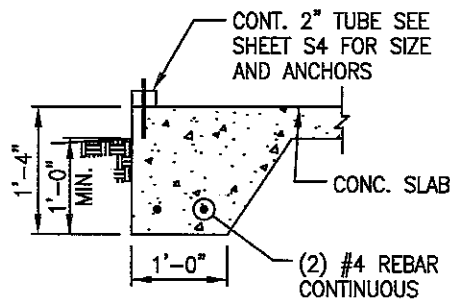
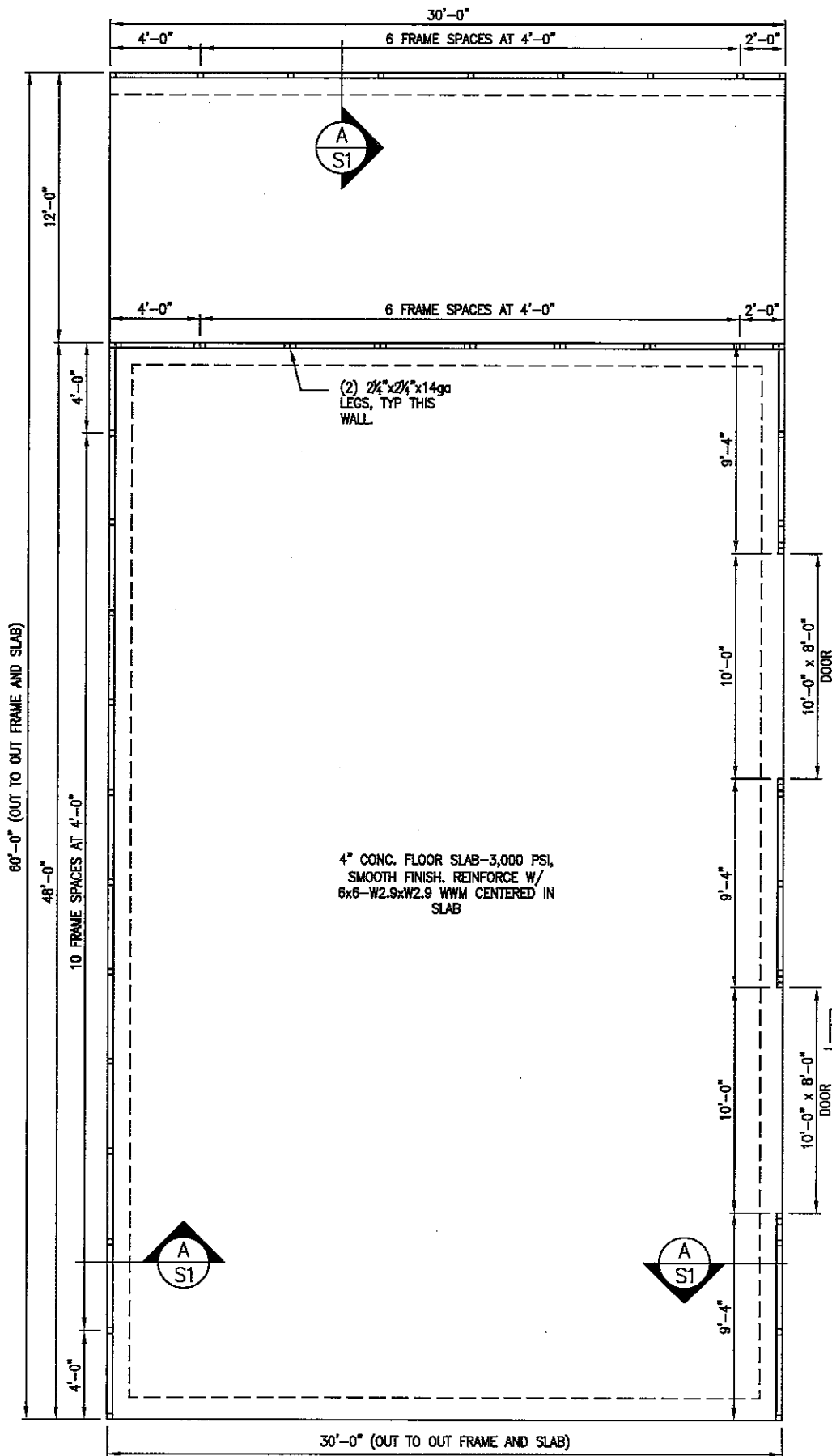

(A) SLAB TURN DOWN
NOT TO SCALE

DRAINAGE NOTE:
OWNER TO PROVIDE POSITIVE DRAINAGE AWAY FROM BLDG. PAD.

FOUNDATION PLAN
NOT TO SCALE

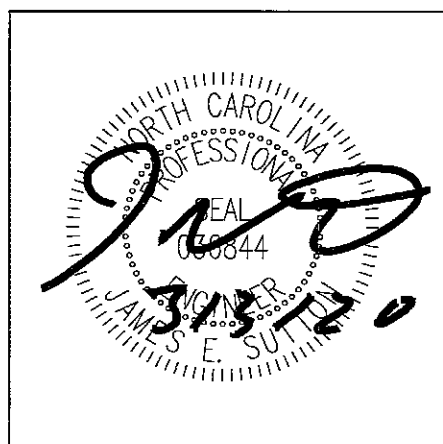



JS CONSULTING & DESIGN
ENGINEERING AND CONSULTING
11703 DURANT RD
RALEIGH, NC 27614
P (919) 675-1480
F (919) 324-3681

CERTIFICATE NUMBER: P-1513

Client:

Luna Metal Buildings and Concrete
904 N Fayetteville St
Asheboro, NC 27203
(o) 336-628-0273

Project:

30'x48'x12' w/ 12'x30'x8' lean to
Joel Lynn
5126 Spring Hill Church Rd
Lillington, NC 27546

Job No:

2001-229R

Date:

03/03/20

Sheet:

S2

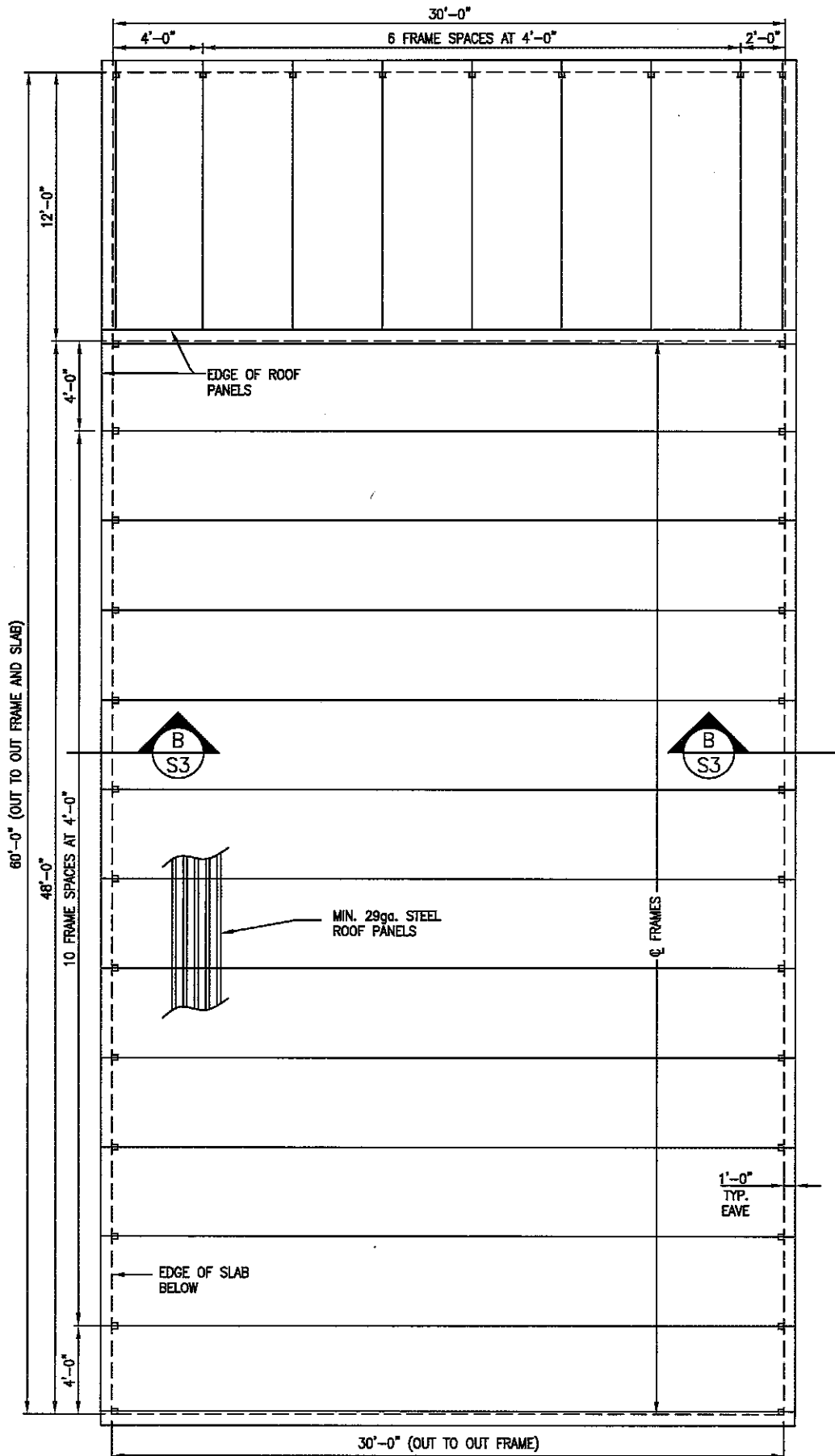

FRAMING PLAN
NOT TO SCALE

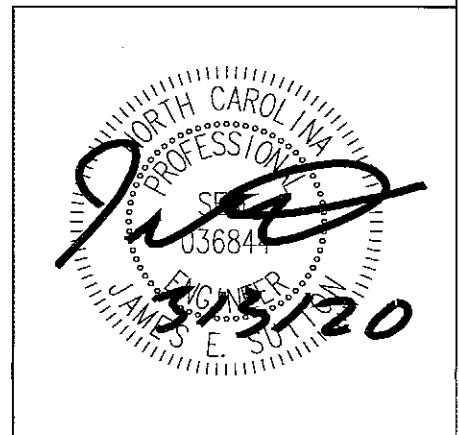



JS CONSULTING & DESIGN
ENGINEERING AND CONSULTING
11703 DURANT RD
RALEIGH, NC 27614
P (919) 675-1680
F (919) 324-3681

CERTIFICATE NUMBER: P-1513

Client:

Luna Metal Buildings and Concrete
904 N Fayetteville St
Asheboro, NC 27203
(o) 336-628-0273

Project:

30'x48'x12' w/ 12'x30'x8' lean to
Joel Lynn
5126 Spring Hill Church Rd
Lillington, NC 27546

Job No:

2001-229R

Date:

03/03/20

Sheet:

S3

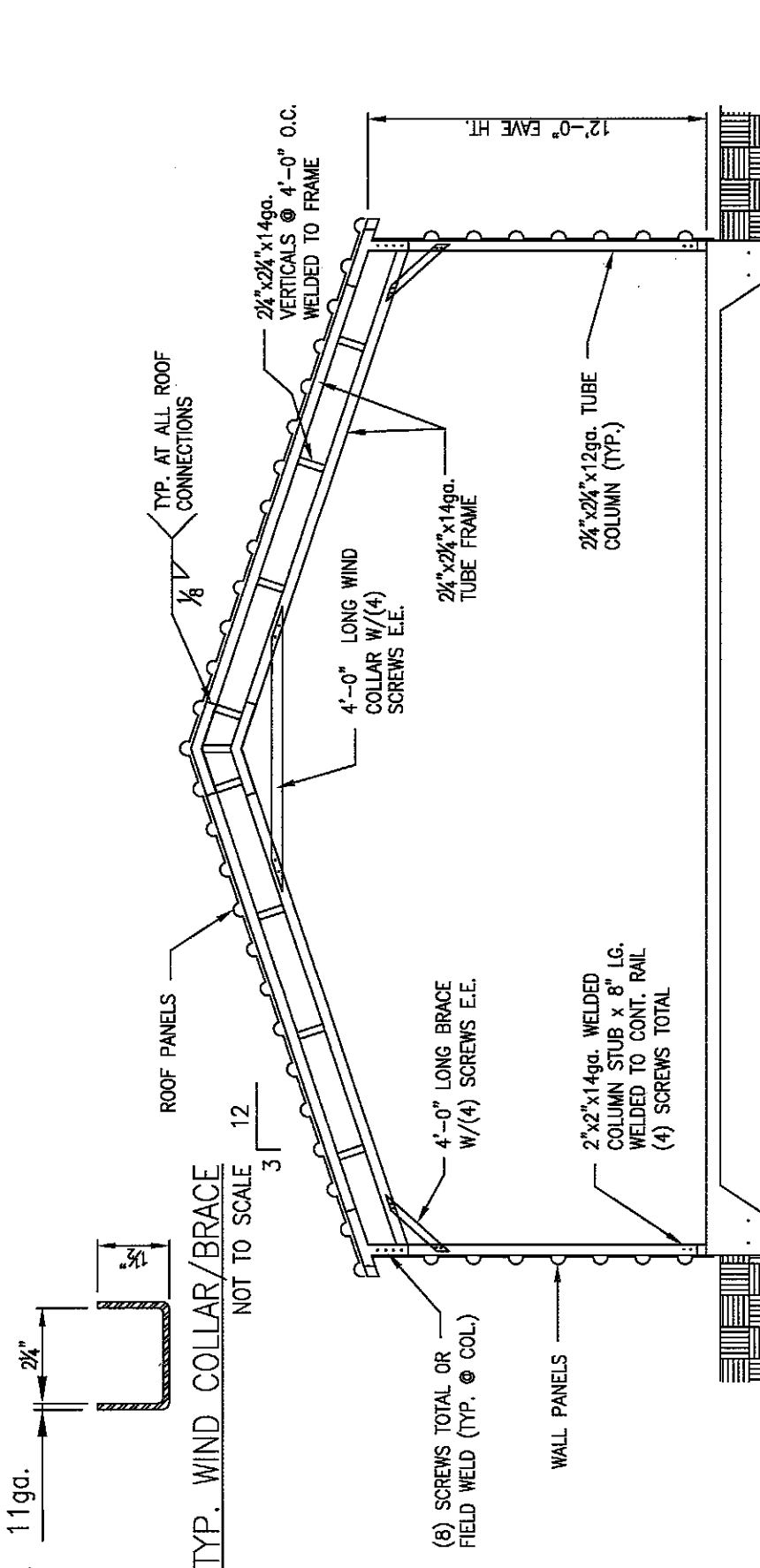

TYPICAL CROSS SECTION B-B
NOT TO SCALE

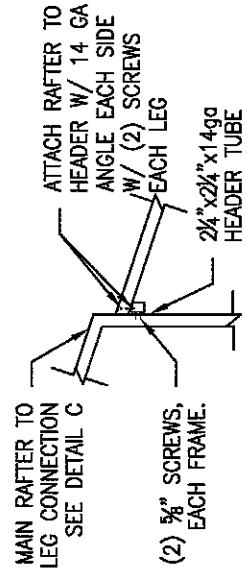

D CONNECTION DETAIL
NOT TO SCALE

GABLE END WALL FRAMING
GABLE END WALLS SHALL BE FRAMED @ 4' O.C.
USING 2-1/4" 14ga SQUARE TUBES TO THE
BOTTOM RAIL AND RAFTERS W/ L-CLIPS AND
(2) SCREWS IN EACH LEG OF THE CLIP. ANY
STUDS OVER 13'-0" IN LENGTH SHALL BE (2)
2-1/4" 14ga AND ATTACHED W/ (2) L-CLIPS
AND (2) SCREWS IN EACH LEG OF THE CLIP.

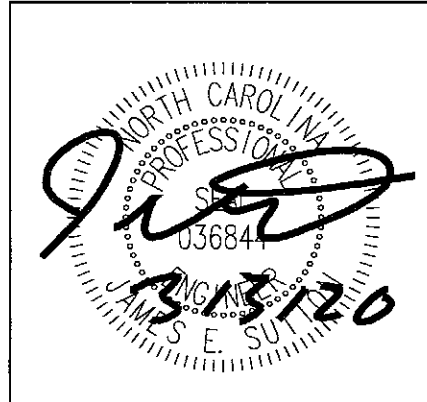



JS CONSULTING & DESIGN
ENGINEERING AND CONSULTING
11763 DURANT RD
RALEIGH, NC 27614
P (919) 875-1680
F (919) 324-3681

CERTIFICATE NUMBER: P-1513

Client:

Luna Metal Buildings and Concrete
904 N Fayetteville St
Asheboro, NC 27203
(o) 336-628-0273

Project:

30'x48'x12' w/ 12'x30'x8' lean to
Joel Lynn
5126 Spring Hill Church Rd
Lillington, NC 27546

Job No:

2001-229R

Date:

03/03/20

Sheet:

S4

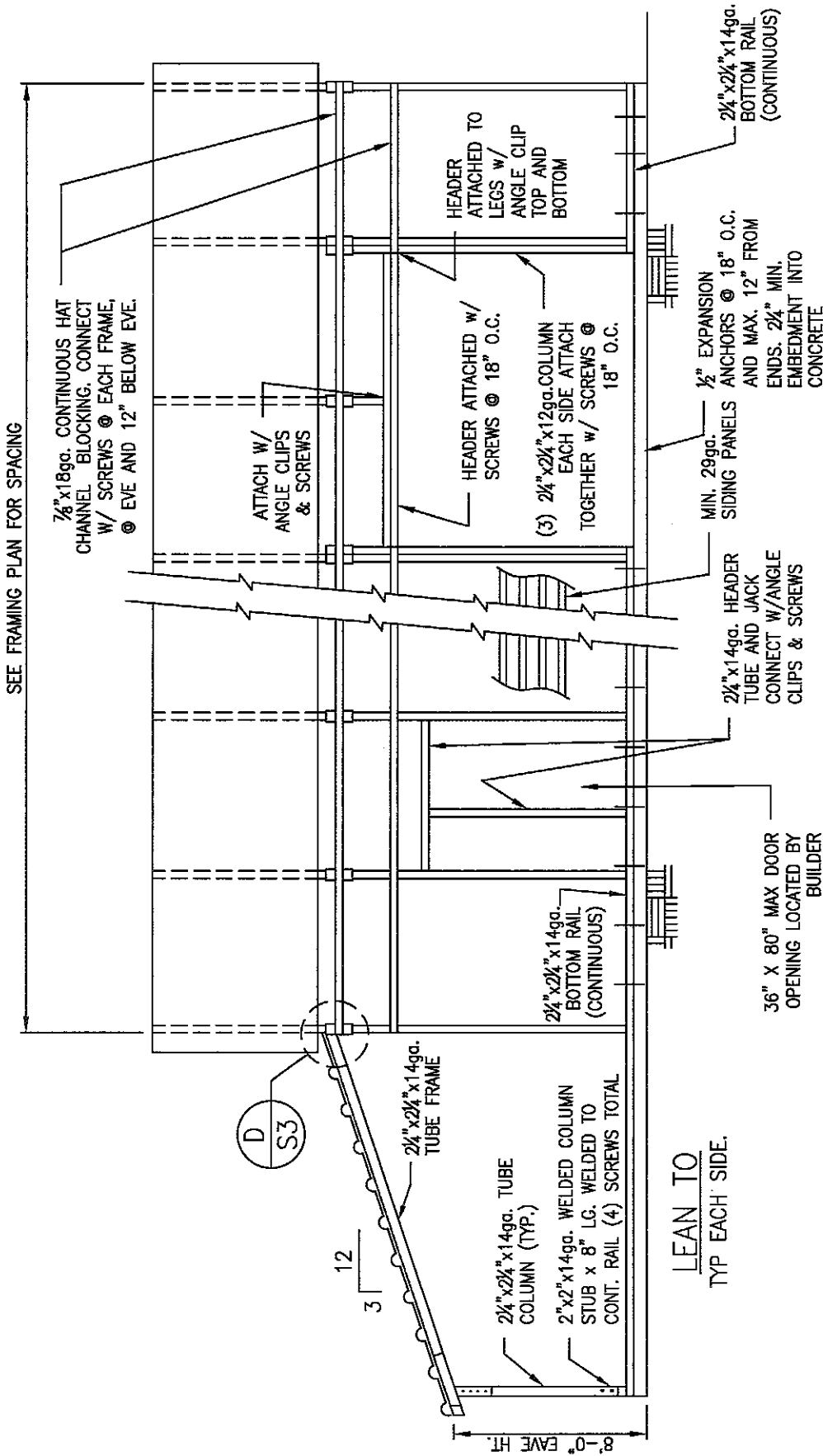

SIDE ELEVATION
NOT TO SCALE

DOOR HEADER SCHEDULE
10'-0" X 8'-0"; (6) 2 1/4" x 2 1/4" x 12ga

ALL ANGLE CLIPS TO HAVE (3) SCREWS
INSTALLED IN EACH LEG OF ANGLE. TYP.

DOOR OPENING NOTE:
FOR DOORS PLACED IN GABLE END WALLS
ONLY, EXACT LOCATION TO BE DETERMINED BY
BUILDER. MINIMUM HEADER SIZE (2) 2-1/4"
14ga SQUARE TUBES ATTACHED TOGETHER W/
CLIPS AND SCREWS @ 1'-0" O.C. MINIMUM (1)
2-1/4" KING STUD EACH SIDE FOR DOORS
LESS THAN 10' WIDE AND (2) 2-1/4" KING
STUD EACH SIDE FOR DOORS 12' AND WIDER.
ATTACH USING ANGLE CLIPS AND SCREWS

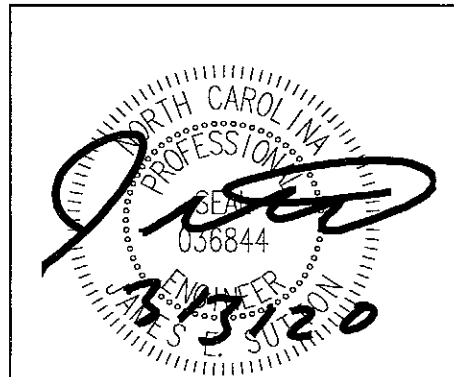

Client:
Luna Metal Buildings and Concrete
904 N Fayetteville St
Asheboro, NC 27203
(o) 336-628-0273

Project:
30'x48'x12' w/ 12'x30'x8' lean to
Joel Lynn
5126 Spring Hill Church Rd
Lillington, NC 27546

Job No:
2001-229R
 Date:
03/03/20
 Sheet:
S5

NOTES

DESIGN CRITERIA

1. BUILDING CODE.....2018 NORTH CAROLINA BUILDING CODE
2. IMPORTANCE FACTORS SNOW (Is) 0.80
 SEISMIC (Iw) 1.0
3. GROUND SNOW LOAD.....15 PSF
4. ROOF LL.....5 PSF (NO FOOT TRAFFIC)
5. WIND
 - A) ULTIMATE WIND SPEED (IBC)120 MPH
 - B) NOMINAL WIND SPEED (ASCE 7-10)93 MPH
 - C) WIND HAZARD EXPOSURE CATEGORY.....B
 - D) WIND BASE SHEARS (for MWFRS) Vx = 2.4 k Vy = 2.4 k (PER FRAME)
6. SEISMIC
 - A) SEISMIC DESIGN CATEGORY A
COMPLIANCE WITH SECTION 1616.4 ONLY? YES X NO
 - B) SEISMIC DESIGN CATEGORY B C X D

SEISMIC USE GROUP 1
 SPECTRAL RESPONSE ACCELERATION Ss 19.6 %g S1 7.3 %g
 SITE CLASSIFICATION D FIELD TEST X PRESUMPTIVE HISTORICAL DATA
 BASIC STRUCTURAL SYSTEM (CHECK ONE)
 BEARING WALL DUAL W/SPECIAL MOMENT FRAME
 BUILDING FRAME DUAL W/INTERMEDIATE R/C OR SPECIAL STEEL
X MOMENT FRAME INVERTED PENDULUM
 SEISMIC BASE SHEAR Vx = 0.5 k Vy = 0.5 k (PER FRAME)

 ANALYSIS PROCEDURE X SIMPLIFIED EQUIVALENT LATERAL FORCE MODAL
 ARCHITECTURAL, MECHANICAL, COMPONENTS ANCHORED? NO
 LATERAL DESIGN CONTROL: EARTHQUAKE WIND X

OTHER NOTES

1. PRESUMPTIVE SOIL PRESSURE = 1,500 PSF.
2. WHERE A DETAIL IS SHOWN ON STRUCTURAL DRAWINGS FOR ONE CONDITION, IT SHALL APPLY TO ALL SIMILAR OR LIKE CONDITIONS, UNLESS NOTED OR SHOWN OTHERWISE.
3. IF CONTRACTOR FINDS A DIFFERENCE BETWEEN THESE DRAWINGS AND EXISTING ELEVATIONS, OR OTHER CONDITIONS WHICH PROHIBIT EXECUTION OF THE WORK AS DIRECTED ON THESE DRAWINGS, CONTRACTOR SHALL NOTIFY ENGINEER IMMEDIATELY.
4. ALL ITEMS SHALL BE TIGHTLY ANCHORED OR ATTACHED SQUARE, PLUMB AND TRUE, OR IN OTHER PLANES OR SHAPES AS SHOWN ON THE DRAWINGS. JOINTS SHALL BE TIGHT, EVEN, AND FREE OF OFFSETS. NO FIELD ALTERING OF ANY MEMBERS WILL BE ALLOWED THAT WILL CAUSE THEM NOT TO BE IN ACCORDANCE WITH THE DRAWINGS AND THEM NOT TO BE IN ACCORDANCE WITH THE DRAWINGS AND SPECIFICATIONS, WITHOUT WRITTEN APPROVAL OF THE DESIGN ENGINEER.
5. GENERAL CONTRACTOR IS RESPONSIBLE TO PROVIDE ADEQUATE SHORING, BRACING OR SUPPORT TO PREVENT MOVEMENT, SETTLEMENT, OR DAMAGE TO THE STRUCTURE DURING CONSTRUCTION PROCEDURES ASSOCIATED WITH THIS PROJECT.
6. CONCRETE: CONCRETE MINIMUM COMPRESSIVE STRENGTH AT 28 DAYS SHALL BE 3000 PSI.
7. CONCRETE WORK SHALL COMPLY WITH ACI *SPECIFICATIONS FOR STRUCTURAL CONCRETE FOR BUILDING (ACI 301) AND APPLICABLE PROVISIONS OF ACI 318. KEEP A COPY OF ACI FIELD REFERENCE MANUAL (ACI-SP-15) WHICH INCLUDES ACI 301 AND OTHER ACI AND ASTM REFERENCES ON THE JOB.
8. ALL FOOTING FOUNDATIONS SHALL BE PLACED ON COMPETENT SOIL.
9. FIBER MESH MAY BE SUBSTITUTED FOR WWM PER MANUFACTURER'S RECOMMENDATIONS.
10. REINFORCING STEEL: ASTM A615, GRADE 60. PROVIDE 3" CLEARANCE TO EARTH SURFACES. LAP BARS 30 DIAMETERS.
11. ALL GALVANIZING SHALL BE PERFORMED AFTER FABRICATION, AND IN ACCORDANCE WITH ASTM A123 AND/OR A153.
12. THE MINIMUM YIELD STRENGTH OF THE STEEL USED IN THE LIGHT GAUGE METAL FRAMES SHALL BE 55,000 PSI, FOR RAW OR GALVANIZED TUBES.
13. THE MINIMUM YIELD STRENGTH OF THE STEEL USED FOR THE LIGHT GAUGE METAL DECK SHALL BE 80,000 PSI, DECKING PANELS SHALL COVER THREE SPANS, MINIMUM.
14. THE LIGHT GAUGE METAL FRAMES AND DECK SHALL BE OF THE GAUGE INDICATED ON THE PLAN/DETAILS.
15. ALL SCREWS FOR ASSEMBLING FRAMES SHALL BE #12 SIZE.
16. ALL WELDING SHALL BE IN ACCORDANCE WITH AWS D1.1.
17. ALL WELDS SHALL BE COATED WITH GALVANIZE PRIMER & PAINT AFTER WELDING.

