

BUILDING DESIGN NOTE-
IN ACCORDANCE WITH THE 2018 INTERNATIONAL BUILDING CODE

STRUCTURAL DESIGN NOTES:

- Contractor to verify all dimensions at construction site prior to beginning construction work.
- Contractor is responsible for compliance with all local building codes and ordinances.
- These notes shall apply where indicated otherwise by drawings or specifications. A detail shown for one condition shall apply for all like or similar conditions unless specific detailing is shown on the plans.
- The contractor shall provide adequate shoring and bracing for all this work during the construction period and protection from the public.
- All roots, stumps and wooden limbs or lumber shall be removed from the entire foundation and underside of slab area.
- Provide sleeves in either foundation or outside wall areas, where needed, for entry of plumbing or electrical service. Seal sleeve openings after plumbing and electrical services have been installed.
- All concrete shall be standard weight 3000psi compressive strength at 28 days unless noted otherwise. Use "Fibermesh" concrete in all slabs on grade.
- Construction or control joints shall be provided in slabs on grade so that the maximum area between joints shall be 800 square feet and the length not more than twice the width.
- Reinforcing bars shall conform to ASTM A-615. All bar sizes #3 and smaller shall be grade 40. Bar sizes #4 and larger shall be grade 60.
- Bending of reinforcing rods by heat shall not be allowed.
- All bolts, plates, clips, anchors, etc., shall be hot-dipped galvanized as per ASTM A-123. All bolts shall be ASTM A-307.
- Apply a protective coat of rust resistant paint to all exposed metal bolts, plates, clips, anchors, etc.
- Install 6 mil polyethylene vapor barrier under slab (and welded wire fabric where used) at all slabs on grade prior to pour. Overlap joints a minimum of (12) twelve inches.
- All compacted fill to be 95% Procter.
- Contractor to establish finished slab elevation per latest F.E.M.A zone requirements.

SPECIAL STRUCTURAL NOTES

- The maximum spans of these buildings is forty (40) feet when using 2 1/2 " 12 gauge, galvanized metal columns.
- The maximum spacing of the 2 1/2 ", 15 gauge or better, galv. column for sidewalls will be (4) feet.
- The max. roof peak height is not to exceed 21 feet. Maintain 5' max for horizontal bracing.
- Columns installed at all door openings (not to exceed 12' wide).
- Use 2 1/2 " sq. overhead header beam over each door opening. Header beams for door openings at the ends to be tied to the matching overhead rafter at three equally spaced joints.

STRUCTURAL MATERIAL COMPONENTS

- 29 gauge "Ground Rib" (BOKS1) steel roofing with a 30 year life span warranty, by Fabral (or approved equal). These sheets are rated as follows:
 - Class 90 uplift test rating (UL 580)
 - Class 4 Impact resistance rating (UL 2218)
 - Class A fire resistance rating (UL 790)
- Fasten sheets to each frame using 12-14, TY 3 point, self-drilling, TEK screws by Rosko Fasteners (or equal).
- Frames to be 2 1/2 " square, 12 gauge, minimum yielding of 50 KSI, galvanized tube steel by Allied Tube and Conduit Co. (or equal).
- Minimum edge distance or spacing for TEK screws is 3/4 ". Two required for each connection.
- Spaces to be 4'-0" max. when using 29 gauge metal.
- Spaces to be 5'-0" max. when more than 50 miles from the coast.
- For vertical sheeting, can run 12'-0" max spacing with horizontal bracing.
- For units or buildings installed 50 miles of coastline that exceed 11' sidewall height, min. of 3' of sheeting shall be installed from the top down and fastened with 12-14, TY 3 point, self-drilling TEK screws by Rosko Fasteners (or equal)

NOTE:

THE FOLLOWING APPLICATIONS AND TOLERANCES ON WIDTH AND LENGTH ON THE FOLLOWING DRAWINGS CAN GO AS WIDE AS 40'-0" IN WIDTH AND DOWN TO 10'-0" IN WIDTH. THE LENGTH CAN GO UP TO 120'-0" AND DOWN TO 10'-0". ALL REQUIREMENTS ARE TO BE FOLLOWED AS INDICATED ON THE DRAWINGS.

NORTH & SOUTH CAROLINA _____ SPAN ROOF SHEETED ONLY
140 MPG WIND / 30 PSF ROOF (LIVE-SNOW)



CUSTOMER NAME: _____
 BUILDING SIZE: _____
 JOB SITE LOC.: _____
 INVOICE # _____ DATE _____
 ADDRESS: _____
 CITY-STATE: _____

GENERAL SPECIFICATIONS

K & G STORAGE, INC.
1736 HWY 301 SOUTH
DILLON, S.C. 29536
KENNY NORRIS (843) 774-2150

Benjamin L. Smith, P.E.
S.C. LIC. # 22439 - N.C. LIC. # 28666

FRAMING PLANS AND DETAILS

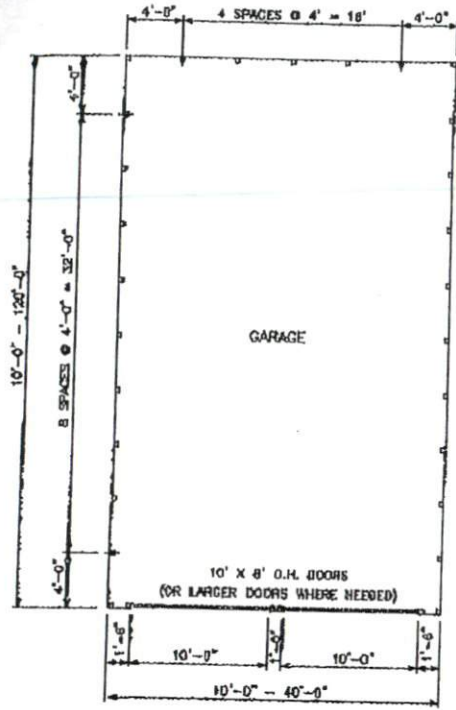

GARAGE

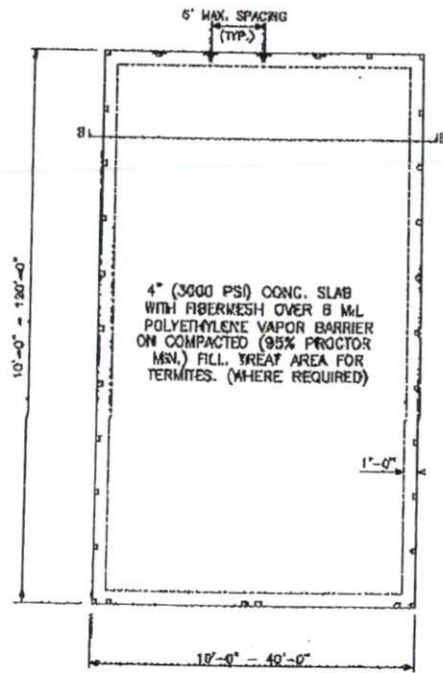

4" (3000 PSI) CONC. SLAB WITH FIBERWESH OVER 8 M.L. POLYETHYLENE VAPOR BARRIER ON COMPACTED (95% PROCTOR MIN.) FILL. GREAT AREA FOR TERMITES. (WHERE REQUIRED)

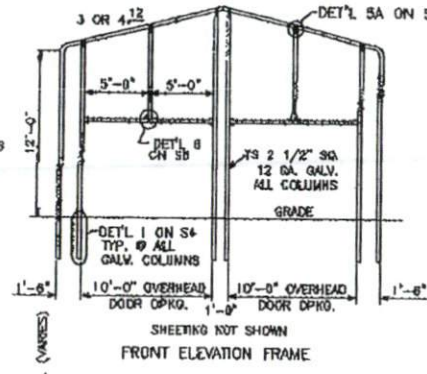

FRONT ELEVATION FRAME

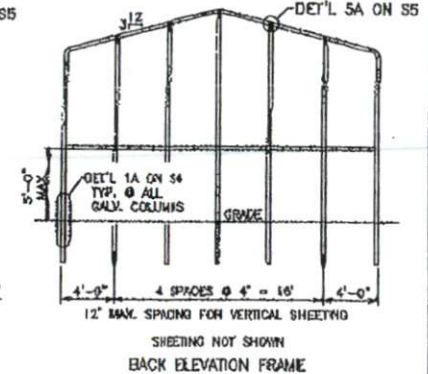

BACK ELEVATION FRAME

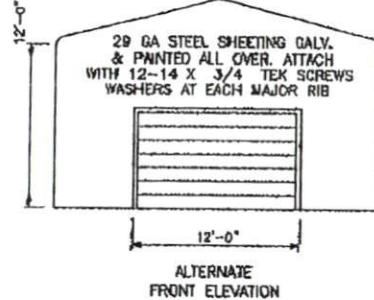

ALTERNATE FRONT ELEVATION

NOTE: 28 FT. TO 40 FT. WIDE, USE "W" TYPE TRUSS. SEE DETAIL ON S5

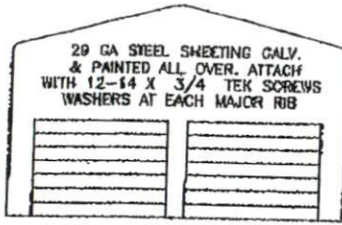

FRONT ELEVATION

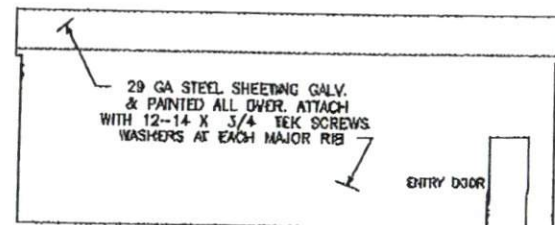

SIDE ELEVATION

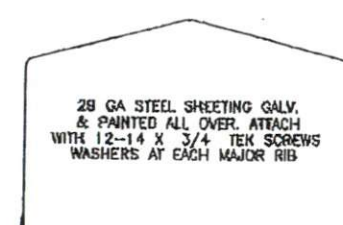

REAR ELEVATION

1. 2018 INTERNATIONAL BUILDING CODE.
2. 140 MPH WIND LOADS ON BUILDING AND ROOF.
3. DP 45 FOR ALL GLASS, IF ADDED.
4. SEISMIC LOAD D-1 IN SITE CLASS D.

5. SOILS DESIGN RESISTANCE OF 1 TON PER SQUARE FOOT.
6. DESIGN DATA
 - a. ROOF L.L. = 30 PSF D.L. = 1 PSF
 - b. SLAB ON GRADE TO CARRY L.L. = 500 PSF



Benjamin L. Smith, PE
S.C. LIC. # 22439 - N.C. LIC. # 28666

DATE:	
TITLE: GARAGE DETAILS	
DESIGNED BY: Benjamin L. Smith	DRAWN BY: Benjamin L. Smith
FOR: K & G STORAGE INC.-DILLON, S.C. 29538 KENNY MORRIS (843) 774-2150	
DATE: N.T.S.	SHEET 52

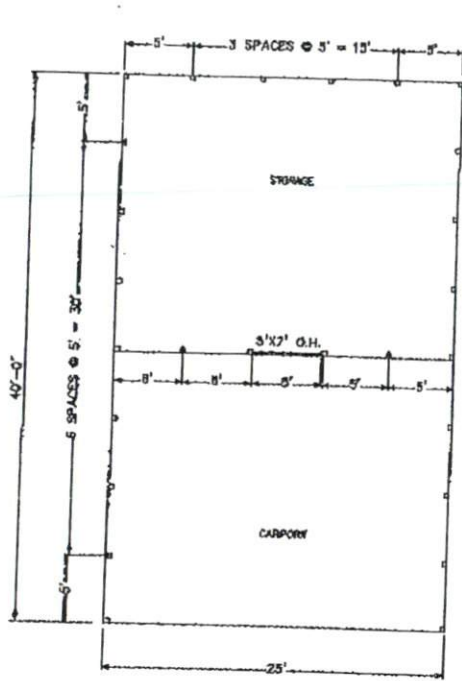

FLOOR PLAN

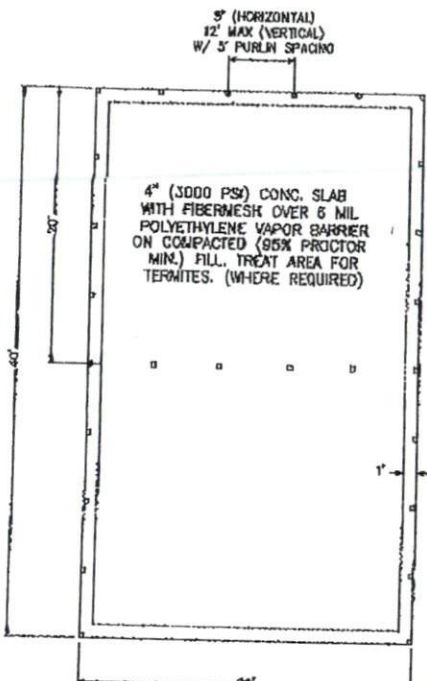

FLOOR PLAN

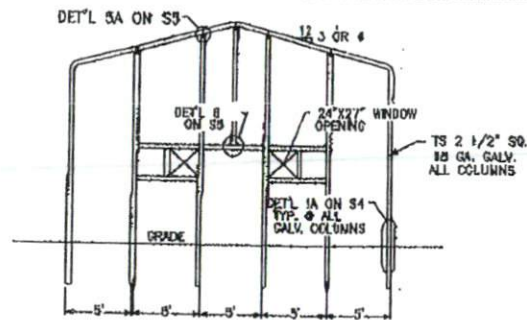

SHEETING NOT SHOWN
FRONT ELEVATION FRAME

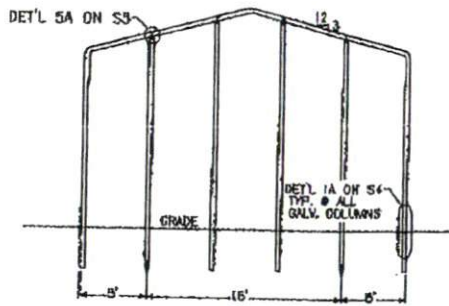

SHEETING NOT SHOWN
REAR ELEVATION FRAME

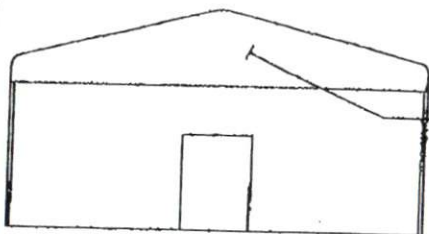

FRONT ELEVATION

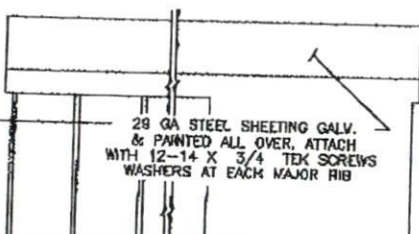

SIDE ELEVATION

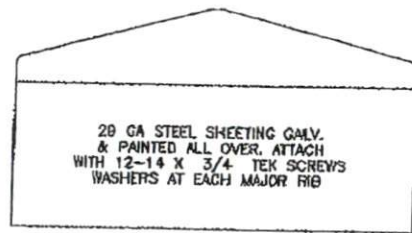

REAR ELEVATION

1. 2018 INTERNATIONAL BUILDING CODE.
2. 140 MPH WIND LOADS ON BUILDING AND ROOF.
3. DP 49 FOR ALL GLASS, IF ADDED.
4. SEISMIC LOAD D-1 IN SITE CLASS D.

5. SO'S DESIGN RESISTANCE OF 1 TON PER SQUARE FOOT.
6. DESIGN DATA
 - a. ROOF L.L. = 30 PSF D.L. = 1 PSF
 - b. SLAB ON GRADE TO CARRY L.L. = 300 PSF



Benjamin L. Smith, PE
S.C. LIC. / 22430 - N.C. LIC. / 28666

PROJECT		
TITLE STORAGE/CARPORT DETAILS		
DESIGNED BY Benjamin L. Smith	DRAWN BY Benjamin L. Smith	
FIRM K & G STORAGE INC. - OLLON, S.C. 29538 KENNY NORRIS (843) 774-2150		
DATE	SCALE	ISSUE NO. / REVISION
	N.P.S.	SHEET 33

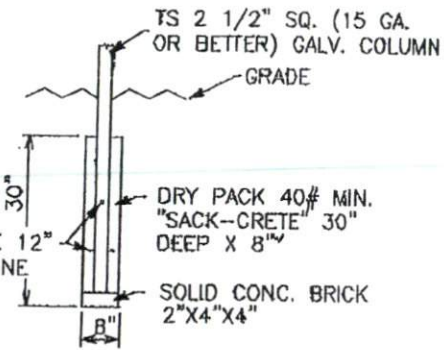

DETAIL 1
(140 MPH WIND LOAD)

2-#4 BARS, ONE 12"
FROM BOT'M & ONE
14" FROM TOP

TS 2 1/2" SQ. (15 GA.
OR BETTER) GALV. COLUMN

GRADE

DRY PACK 40# MIN.
"SACK-CRETE" 30"
DEEP X 8"

SOLID CONC. BRICK
2"X4"X4"

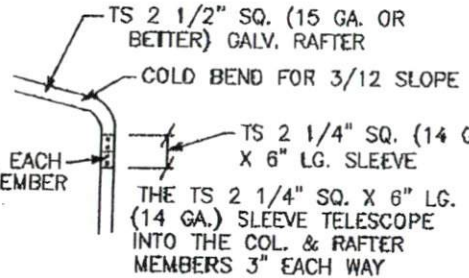

DETAIL 2
(140 MPH WIND LOAD)

(2) 3/4" TEK SCREWS, EACH
SIDE, EACH MEMBER

TS 2 1/2" SQ. (15 GA. OR
BETTER) GALV. RAFTER

COLD BEND FOR 3/12 SLOPE

TS 2 1/4" SQ. (14 GA)
X 6" LG. SLEEVE

THE TS 2 1/4" SQ. X 6" LG.
(14 GA.) SLEEVE TELESCOPE
INTO THE COL. & RAFTER
MEMBERS 3" EACH WAY

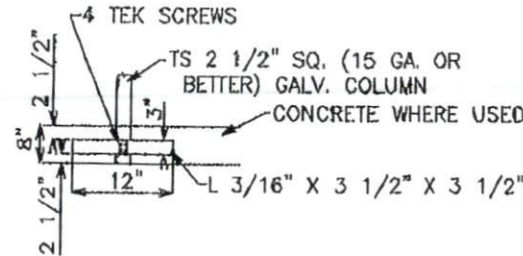

DETAIL 1A
(OPTIONAL REPLACEMENT
FOR DETAIL 1)
(140 MPH WIND LOAD)

TS 2 1/2" SQ. (15 GA. OR
BETTER) GALV. HORIZ.
BRACE

4 TEK SCREWS

TS 2 1/2" SQ. (15 GA. OR
BETTER) GALV. COLUMN

CONCRETE WHERE USED

L 3/16" X 3 1/2" X 3 1/2"

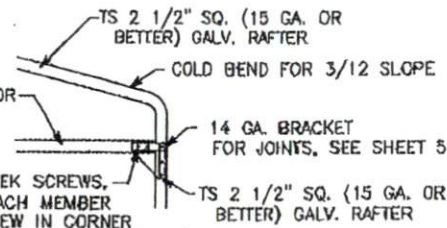

DETAIL 4
(140 MPH WIND LOAD)

(2) 3/4" TEK SCREWS,
EACH SIDE, EACH MEMBER

(1) 3/4" TEK SCREW IN CORNER

TS 2 1/2" SQ. (15 GA. OR
BETTER) GALV. RAFTER

COLD BEND FOR 3/12 SLOPE

14 GA. BRACKET
FOR JOINTS, SEE SHEET 5

TS 2 1/2" SQ. (15 GA. OR
BETTER) GALV. RAFTER

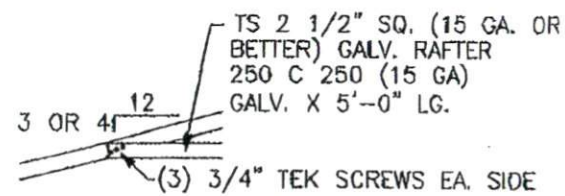

DETAIL 3
(140 MPH WIND LOAD)

TS 2 1/2" SQ. (15 GA. OR
BETTER) GALV. RAFTER

250 C 250 (15 GA)

GALV. X 5'-0" LG.

(3) 3/4" TEK SCREWS EA. SIDE

FASTEN "C" SECTION TO
TUBE SECTION WITH
(6) 3/4" TEK SCREWS
EACH SIDE

(2) 3/4" TEK SCREWS, EACH
SIDE, EACH MEMBER

TS 2 1/2" SQ. (15 GA. OR
BETTER) GALV. RAFTER

14 GA. CORNER BRACKET
SEE SHEET S6 FOR DETAIL

DETAIL 2A
(OPTIONAL REPLACEMENT
FOR DETAIL 2)
(140 MPH WIND LOAD)



Benjamin L. Smith, PE
S.G. U.C. #22439 - N.C. U.C. #28666

DATE			
TITLE STRUCTURAL DETAILS			
DESIGNED BY Benjamin L. Smith	DRAWN BY Benjamin L. Smith		
FOR K & G STORAGE INC.-DILLON, S.C. 29538 KENNY KORRIS (843) 774-2150			
DATE N.T.S.	SHEET NUMBER SHEET 54		

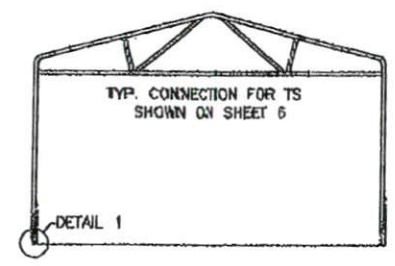
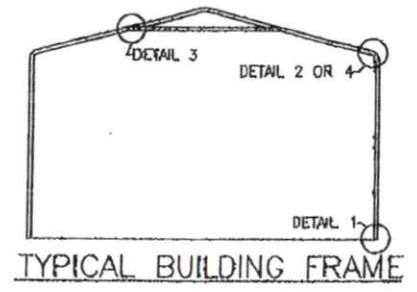
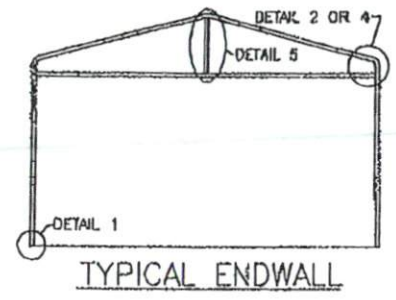
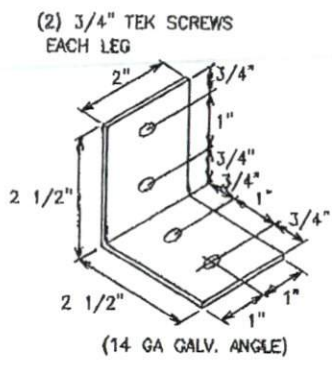
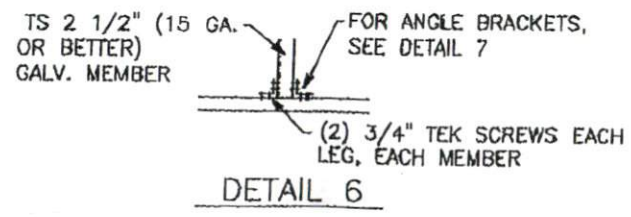
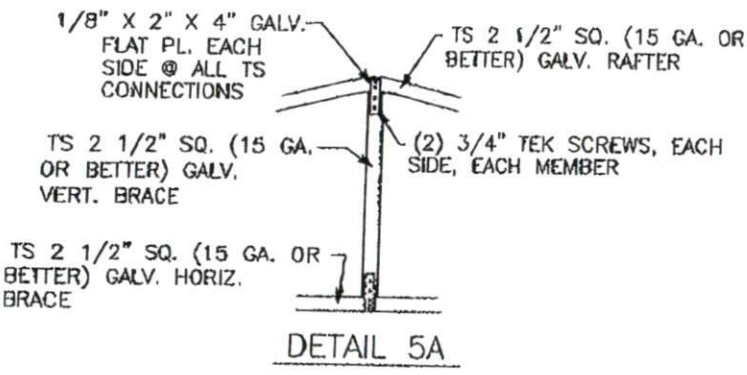
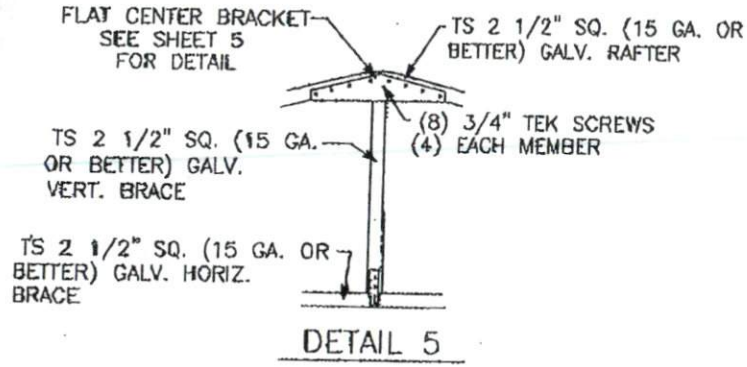

Benjamin L. Smith, PE
S.C. LIC. #22439 - N.C. LIC. #28666

REVISIONS			
TITLE STRUCTURAL DETAILS			
DESIGNED BY	Benjamin L. Smith	DRAWN BY	Benjamin L. Smith
DATE	X & O STORAGE INC.-GILLOM, S.C. 28536 KENNY MORRIS (843) 774-2150		
SCALE	N.T.S.	SHEET NUMBER	SHEET 59

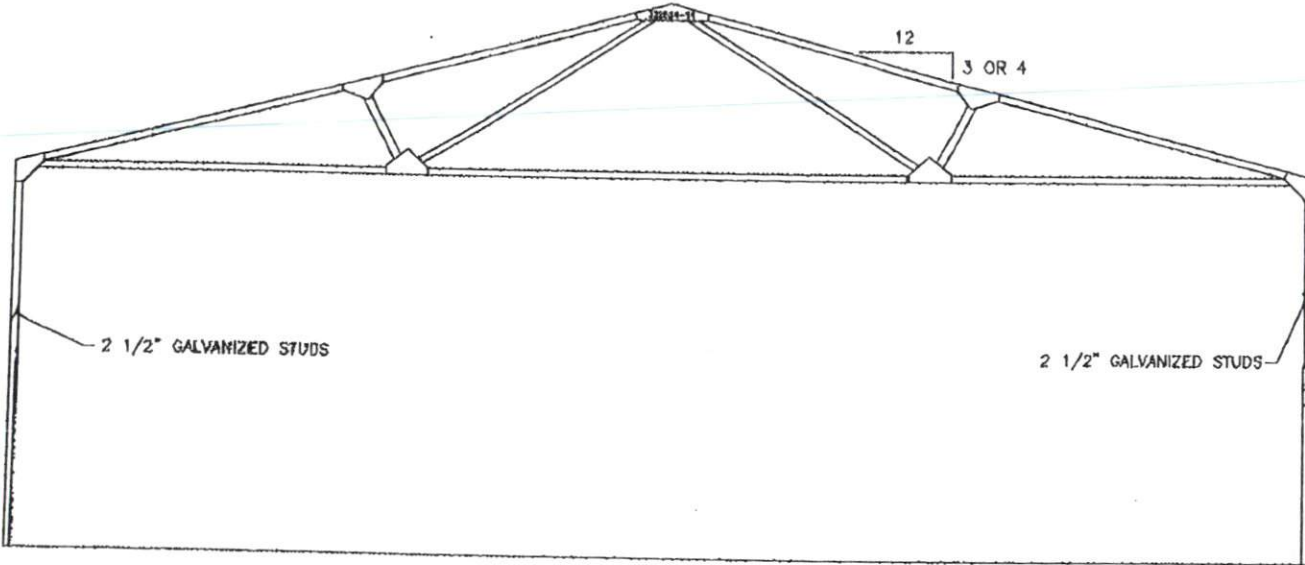

SECTION
 "W" TRUSS FOR 26' TO 40' SPAN
 TYPICAL DETAIL

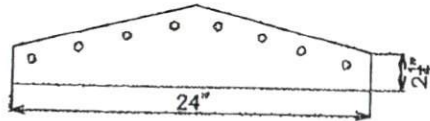

FLAT CENTER BRACKET

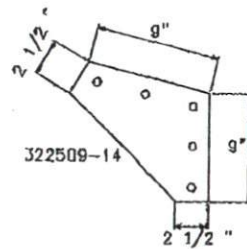

14 GA. BRACKET
 FOR TRUSS JOINTS



Benjamin L. Smith, PE
 S.C. LIC. #22430 - N.C. LIC. #28688

TITLE		
W TRUSS FOR 26' TO 40' SPAN TYPICAL DETAIL		
DESIGNED BY	Benjamin L. Smith	CHECKED BY
Benjamin L. Smith		Benjamin L. Smith
PROJECT		
K & G STORAGE INC.-OLLOK, S.C. 29538 KENNY MORRIS (843) 774-2150		
DATE	SCALE	SHEET NO.
	N.Y.S.	SHEET-60

14-10 010101022

2 1/2" W
 SIDE ELEV
 TO CARPORT
 YERNATE CARPOR
 FOOTER SUPP
 ovn L. Smith
 G STORAGE INC.-
 KENNY MORRIS (8
 N.Y.S.

Norris

Storage Buildings & Carports, LLC

8863 Fayetteville Road
Raeford, NC 28376
Phone: 910-875-1560

1001 East 4th Ave
Red Springs, NC 28377
Phone: 910-843-8920

2948 Gillespie St
Fayetteville, NC 28306
Phone: 910-424-0514

www.NorrisStorageBuildings.com

Date:

Ordered By

Name:

Address:

City, State:

Zip:

Phone:

Delivery Date:

Contact Name:

Deliver To

Name:

Address:

City, State:

Zip:

Remarks:

Dealer:

Terms:

PO#/Contract#:

Check #:

Credit Card:

Cash:

Size	Description	Quantity	Unit Price	Amount
24 X 41	NORGUARD GARAGE BLACK ROOF SIDES DARK RED	1	\$11,495.00	\$11,495.00
	TRIM WHITE 1 A/C CUTOUT NO CONCRETE			
	2 ES 10X8 G DOOR 1 6 PANEL SERVICE DOOR			

Sub-total \$11,495.00

TAX \$804.65

Grand Total \$12,299.65

All sales which include concrete slab price is based on lot being level. Additional ground prep may be charged for un-level ground.

No Refunds on Deposits. Customers are responsible for all permits.

Internal Use Only

Amount Paid:	\$2,000.00
Paid Date:	2020/12/01

Signature 