

Enoc and Raven Vazquez
 986 Atkins Rd.
 Fuquay-Varina, NC 27526

Homeowners Drawing

"Free Standing Flat Roof"

Wake Med Birth Cente 9193504873 >> 910 893 2793

2020-03-11 07:23

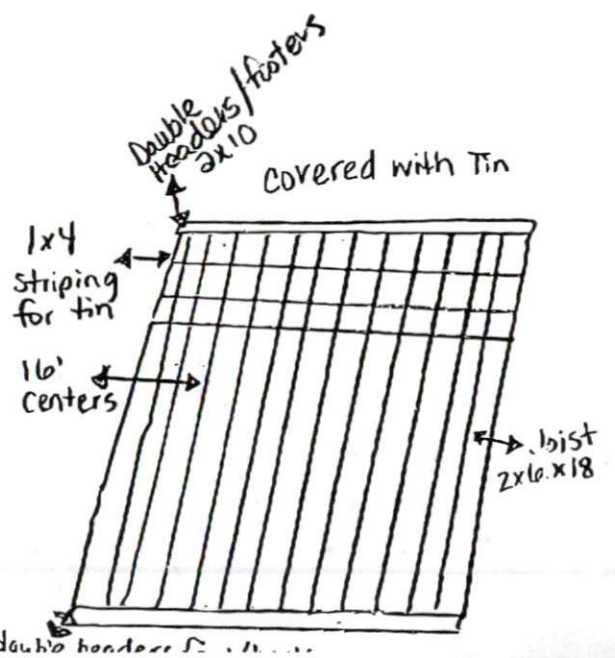
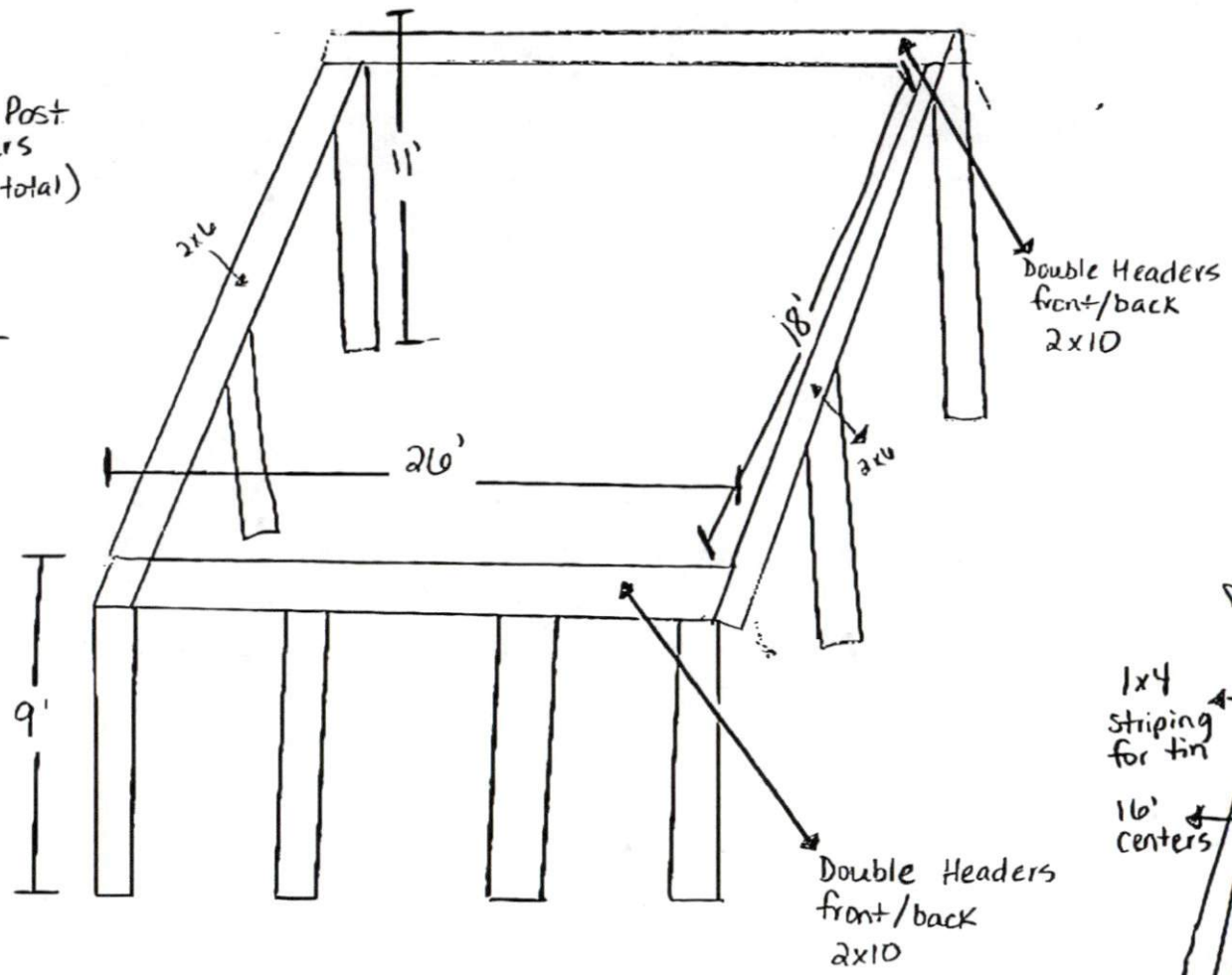
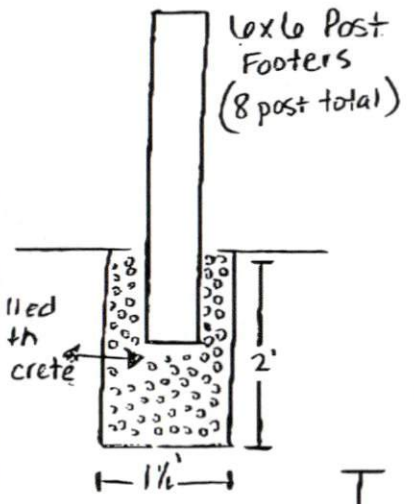

6x6 Post
 2x6 Rafters
 16' centers

Building Sketch

Borrower/Client	Revan Vazquez						
Property Address	988 Atkins Rd						
City	Fuquay Varine	County	Hamett	State	NC	Zip Code	27528
Lender	Wells Fargo Bank, N.A. - 0036847						

Backyard

(Proposed free standing Flat roof)

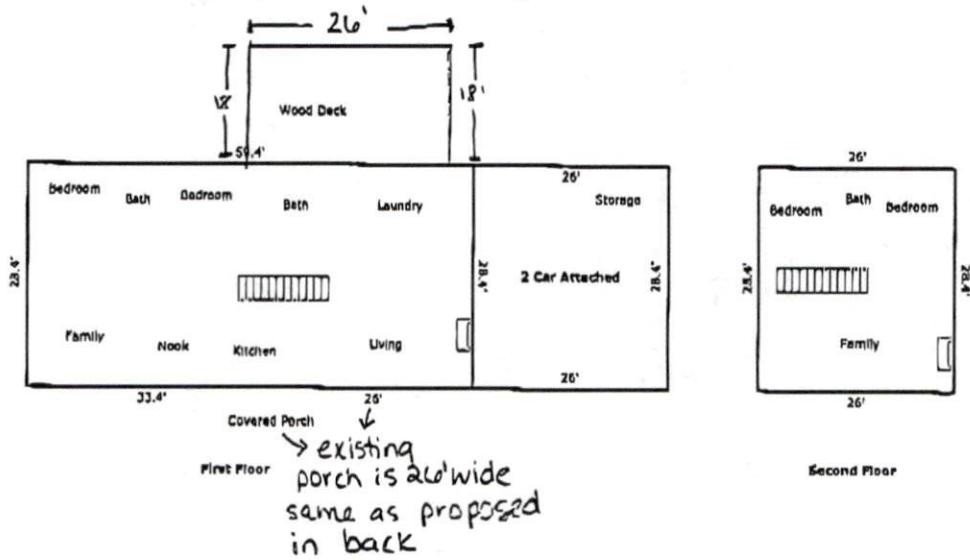

Frontyard

TOTAL Sketch by e la mode, inc.		Area Calculations Summary	
Living Area		Calculation Details	
First Floor	1606.96 Sq ft	$26.4 \times 59.4 =$	1606.96
Second Floor	738.4 Sq ft	$26 \times 28.4 =$	738.4
Total Living Area (Rounded):	2425 Sq ft		
Non-living Area			
2 Car Attached	738.4 Sq ft	$26.4 \times 26 =$	738.4