

207°EW / 94°SW  
 241 PLF EFFECTIVE LENGTHS  
 BASED ON SW-31.10...la.E.17...78.1-2  
 ENGINEERED METHOD.  
 UNBLOCKED DIAPHRAGM SW-20-237B.1  
 100 MPH WIND SPEED

NC REQUIREMENTS  
 COLUMNS PER MW-20.3.R.G.M.47.20 (8' SIDEWALLS)  
 RIDGE BEAM PER RC-60.3.R.G.M.20  
 SIDEWALL HEADERS PER EW-20.3.R.G.E.22.20 (100 MPH)

RETURN AIR REQUIREMENTS  
 ① 20"x30" GRILL REQUIRED  
 ② 4"x10" GRILL W/ 2 1/2" DOOR UNDERCUT  
 ③ DOOR(S) MUST BE UNDERCUT 2 1/2" MIN.  
 ④ 4"x24" OR 6"x14" GRILL REQUIRED

INDICATES FREE END SHEAR WALL WITH STRAPS OR BLOCK PER SHEARWALL PAGE.  
 THE \* SPECIFIES THAT THERE CAN BE NO HOLES IN STUDS IN COLUMNS

BRAND	SCHULT
SERIES	GM28
OAKWOOD HOMES CORP.	

REVISIONS	BY	DATE	GENERAL NOTES
ADDED COVERAGE TO INSIDE SHOWER WALLS	EXP	01/20/17	CEILING HEIGHT = 96.00
UTILITY DOOR UNDERCUT FOR RETURN AIR	EXP	07/20/16	
CHANGED MBR AND MBR CLOSET TO 3.0 DOORS PER MICHAEL	EXP	06/28/16	
ADJUSTED DIMS FLOOR DWV	EXP	06/17/16	FLOOR FRAMING SPACING = 16
CREATED NEW PATRIOT OFF SW247962	EXP	04/08/16	TOTAL WINDOW SQFT = 209.97

DRAWING TITLE  
**MASTER PLAN  
 FURNACE 3610**

MODEL NAME	WASHINGTON-MOD		SQ. FT.	1502	
PLANT	958	DESCRIPTION	28X56 3BR-2BA	MODEL NO.	SN251511
DRAWN BY	TXH	ORIG. DATE	11/14/2019	DATE PRINTED	12/30/2019
				SHEET NO.	1-1

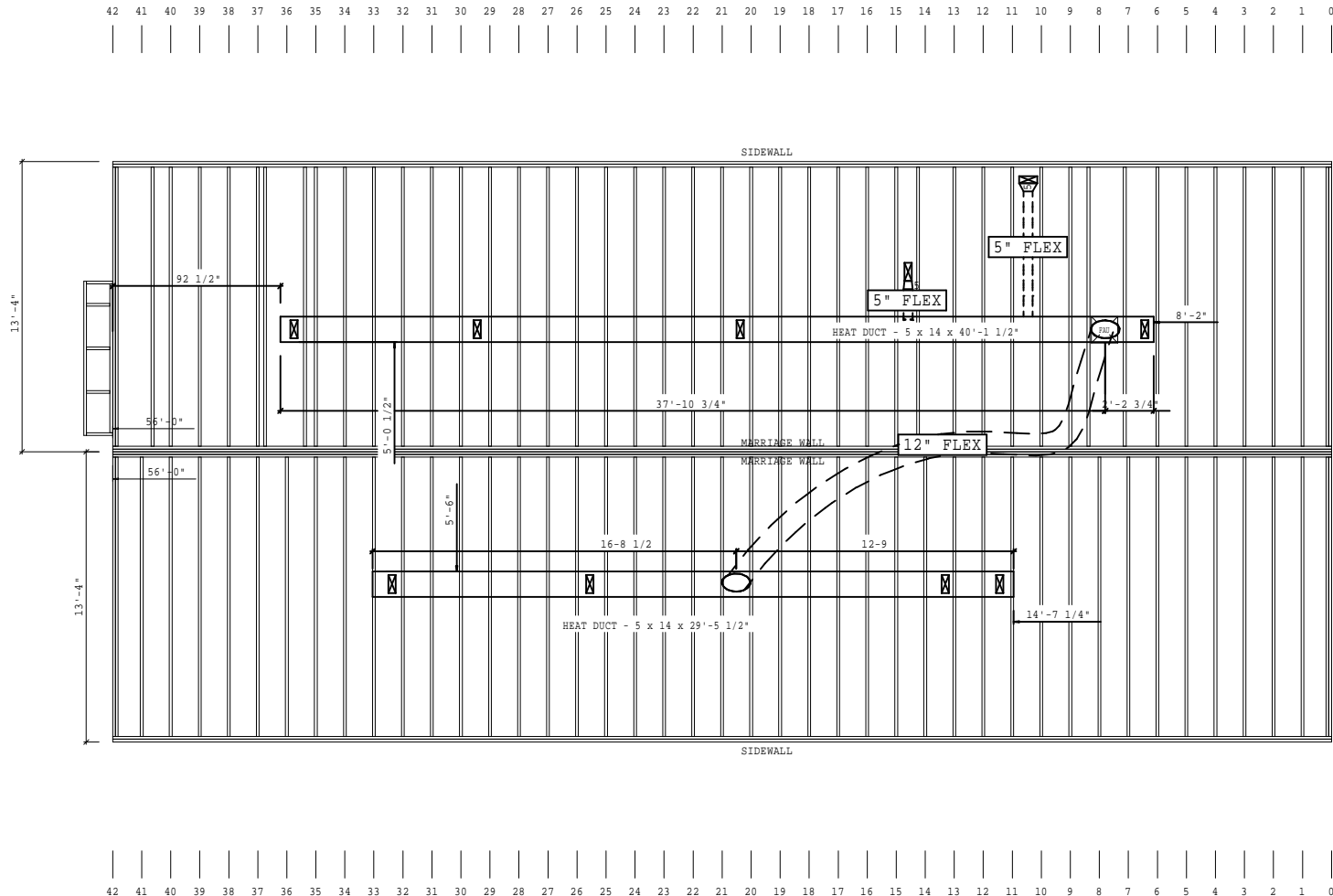

A-SECTION HITCH END

B-SECTION HITCH END

BRAND	SCHULT	SERIES	GM28
OAKWOOD HOMES CORP.			

REVISIONS	BY	DATE
UTILITY DOOR UNDERCUT FOR RETURN AIR	EXP	07/20/16
CHANGED MBR AND MBR CLOSET TO 3.0 DOORS PER MICHAEL	EXP	06/28/16
ADJUSTED DIMS FLOOR DMV	EXP	06/17/16
CREATED NEW PATRIOT OFF SN247962	EXP	04/08/16

GENERAL NOTES

DRAWING TITLE	INLINE LOOP HVAC
---------------	------------------

MODEL NAME	WASHINGTON-MOD		SQ. FT.	1502
PLANT	DESCRIPTION	MODEL NO.		
958	28X56 3BR-2BA	SN251511		
DRAWN BY	ORIG. DATE	DATE PRINTED	SHEET NO.	
TXH	11/14/2019	12/30/2019	4-3	

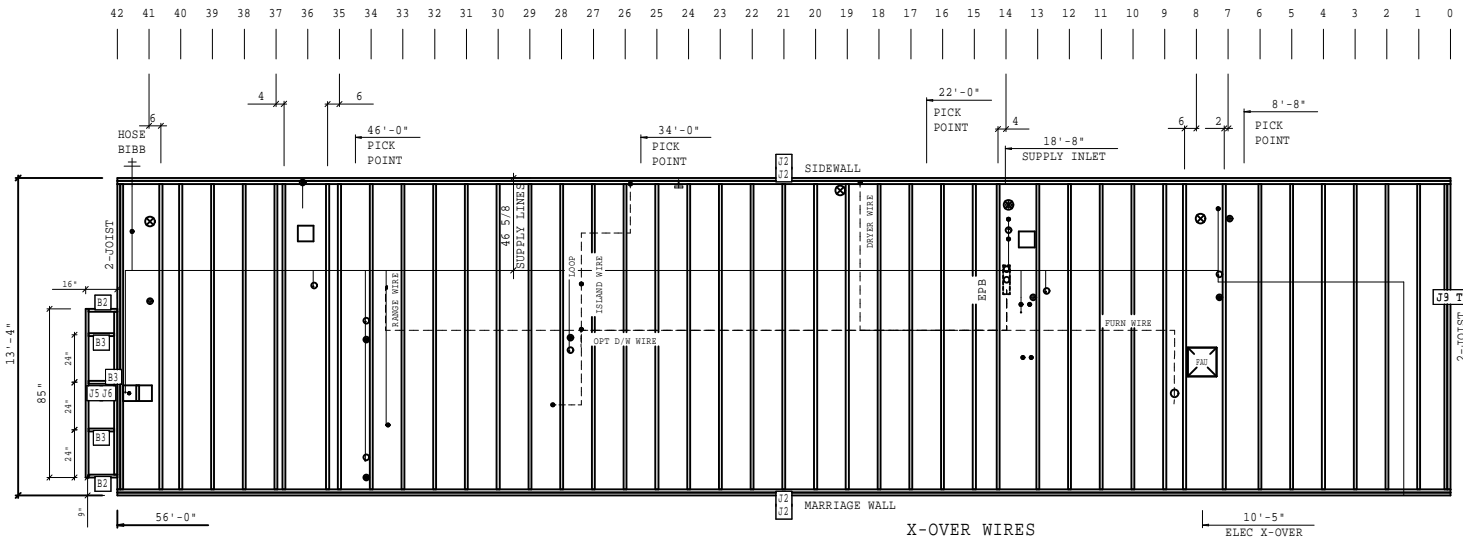

X-OVER WIRES  
3-14

FLOOR JOIST SCHEDULE					WIRING SCHEDULE					
LAB	QTY	MAT	LENGTH	OPT USE IF/APPL.	DESCRIPTION	SIZE	LENGTH	DESCRIPTION	SIZE	LENGTH
B2	2	2x10J	14 1/2'		ISLAND REC	12	15'0"	ELEC. RANGE	8	38'0"
B3	3	2x10J	13'		GAS RANGE	12	38'0"	DISHWAHER OPT	14	28'0"
J1	46	2x10J	154'		DRYER	10	22'0"	ELEC. FAU	5/10	21'0"
J2	4	2x10J	672'		GAS FAU	12	21'0"			
J5	1	2x10J	85'		STANDARD SHIP LOOSE					
J6	1	2x10J	82'		1.5" PIPE		10 FT			
					2" PIPE		20 FT			
					3" PIPE		75 FT			

BRAND SCHULT	SERIES GM28	REVISIONS			BY	DATE	GENERAL NOTES			DRAWING TITLE <b>FLOOR FRAMING-A</b>	MODEL NAME WASHINGTON-MOD	SQ. FT. 1493	
OAKWOOD HOMES CORP.		UTILITY DOOR UNDERCUT FOR RETURN AIR	EXP	07/20/16	6-3 - DENOTES LOCATION OF PLUMBING BLOCKS FOR DRAIN LINES					PLANT 958	DESCRIPTION 28X56 3BR-2BA	MODEL NO. SN251511	
		CHANGED MBR AND MBR CLOSET TO 3.0 DOORS PER MICHAEL	EXP	06/28/16	SET WATER AND DRAIN LINES ACCORDING TO DIMENSIONS					DRAWN BY TXH	ORIG. DATE 11/14/2019	DATE PRINTED 12/30/2019	SHEET NO. 5-1A
		ADJUSTED DIMS FLOOR DMV	EXP	06/17/16	TUB ACCESS UNDER FLOOR BETWEEN FLOOR JOISTS								
		CREATED NEW PATRIOT OFF SN247962	EXP	04/08/16	ALL JOIST DIMENSIONS ARE TO CENTER DO NOT INSTALL INS OR BOT BRD IN REC/PORCH AREAS THAT UTILIZE TREATH MATERIALS								

FLOOR JOIST SCHEDULE				
LAB	QTY	MAT	LENGTH	OPT USE IF/APPL.
J1	45	2x10J	154"	
J2	4	2x10J	672"	

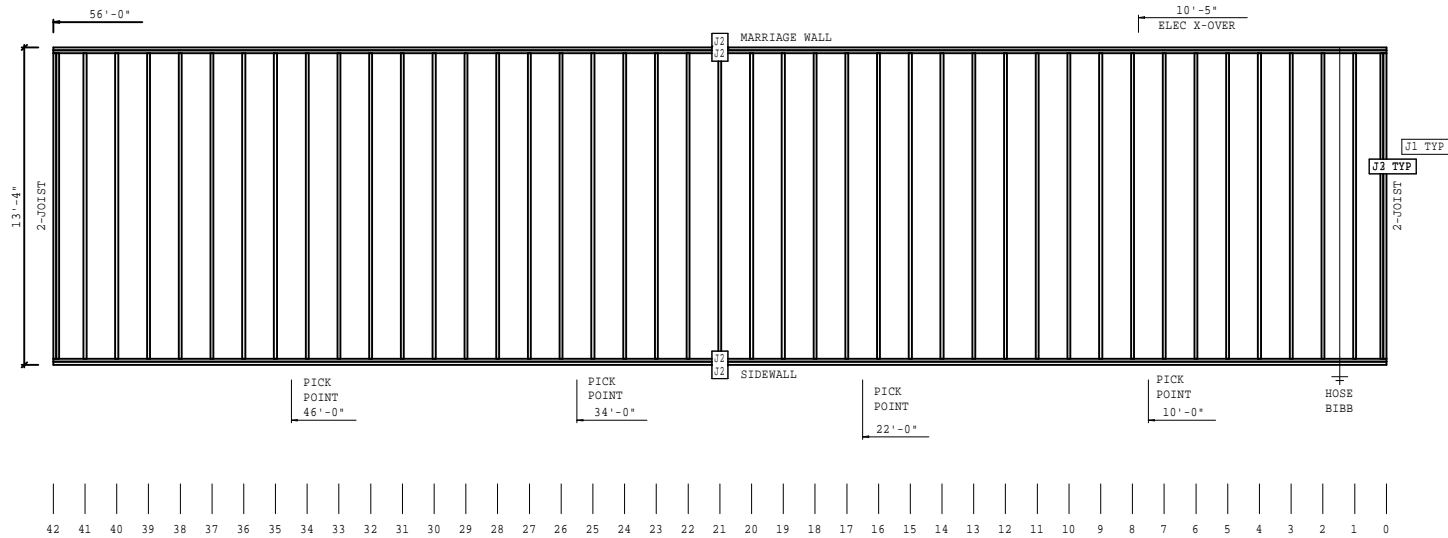

BRAND SCHULT	SERIES GM28	REVISIONS		BY	DATE	GENERAL NOTES 6.3 - DENOTES LOCATION OF PLUMBING BLOCKS FOR DRAIN LINES SET WATER AND DRAIN LINES ACCORDING TO DIMENSIONS TUB ACCESS UNDER FLOOR BETWEEN FLOOR JOISTS ALL JOIST DIMENSIONS ARE TO CENTER DO NOT INSTALL INS OR BOT BRD IN REC/PORCH AREAS THAT UTILIZE TREATH MATERIALS	DRAWING TITLE <b>FLOOR FRAMING-B</b>	MODEL NAME WASHINGTON-MOD	SQ. FT. 1493
OAKWOOD HOMES CORP.		UTILITY DOOR UNDERCUT FOR RETURN AIR	EXP	07/20/16			PLANT 958	DESCRIPTION 28X56 3BR-2BA	MODEL NO. SN251511
		CHANGED MBR AND MBR CLOSET TO 3.0 DOORS PER MICHAEL	EXP	06/28/16			DRAWN BY TXH	ORIG. DATE 11/14/2019	DATE PRINTED 12/30/2019
		ADJUSTED DIMS FLOOR DWV	EXP	06/17/16			SHEET NO. 5-1B		
		CREATED NEW PATRIOT OFF SN247962	EXP	04/08/16					

\*NOTE\*  
 DASHED LINES REPRESENT BELOW  
 FLOOR DWV PIPE TO BE FIELD INSTALLED  
 BY OTHERS. LAYOUT MAY VARY  
 DUE TO SITE CONDITIONS.  
 BUILDER IS RESPONSIBLE TO  
 ASSURE THAT FINAL SYSTEM  
 CONFORMS TO ALL APPLICABLE CODES.

PIPING AND FITTING MATERIAL TYPE TO BE:  
 ABS (ACRYLONITRILE-BUTADIENE-STYRENE)  
 OR PVC (POLYVINYL CHLORIDE)

PIPE LEGEND

	1 1/2"
	2"
	3"

STANDARD SHIP LOSS

D	2
E	1
F	3
M	1
N	1
O	4
OO	1
P	2
PP	3
Q	6
U	2
1.5" PIPE	10 F'
2" PIPE	20 F'
3" PIPE	75 F'

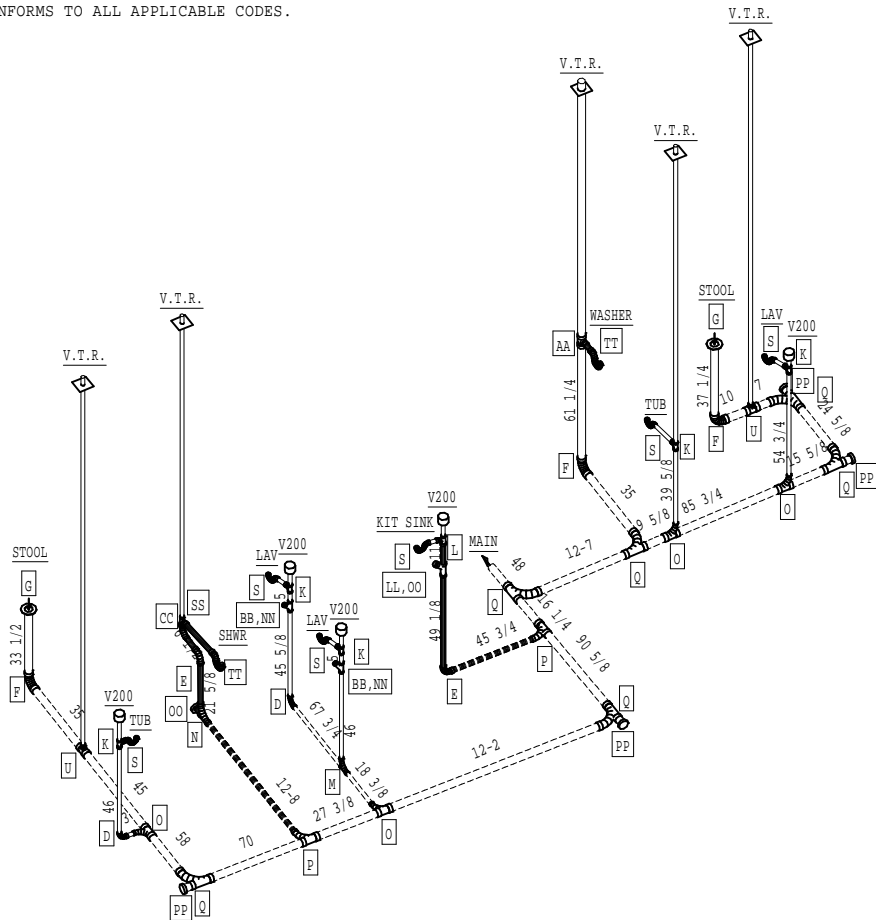

NOTE:  
 ACCESS SHALL BE PROVIDED TO ALL AIR ADMITTANCE VALVES. THE VALVE SHALL  
 BE LOCATED WITHIN A VENTILATED SPACE THAT ALLOWS AIR TO ENTER THE VALVE

LET	DESCRIPTION	LET	DESCRIPTION	LET	DESCRIPTION	LET	DESCRIPTION
A	1.5" x 45° LT-1/8 BEND	B	2" x 45° LT-1/8 BEND	C	3" x 45° LT-1/8 BEND	D	1.5" x 90° LONG SWEEP-1/4 BEND
E	2" x 90° LSWEEP-1/4 BEND	F	3" x 90° LSWEEP-1/4 BEND	G	4"x3" CLOSET FLANGE	H	2"x1.5" FLUSH BUSHING
I	3"x1.5" FLUSH BUSHING	J	3"x2" FLUSH BUSHING	K	1.5" SANITARY TEE	L	2"x1.5"x1.5" SAN TEE
M	1.5" LTTY	N	2" LTTY	O	3"x3"x1.5" LTTY	P	3"x3"x2" LTTY
Q	3" LTTY	R	3" 3-WAY ELBOW	S	1.5"x1.5" P-TRAP	T	3"x3"x1.5"x1.5" DBL SAN TEE
U	3"x3"x1.5" SAN TEE	V	1.5" x 90° LONG SWEEP STREET	W	3" SANITARY TEE	X	3"x3"x1.5" WYE
Y	2" 3-WAY ELBOW	Z	2"x2"x1.5" LTTY	AA	3"x3"x2" SAN TEE	BB	1.5" x 45° WYE
CC	2" x 90° LSWEEP STREET	DD	1.5" x 45° 1/8 BEND STREET	EE	1.5" COUPLING	FF	3" COUPLING
GG	1.5" P-TRAP @ WASHER	HH	1.5" SAN TEE STREET	II	2"x1.5"x1.5" LTTY	JJ	2"x1.5"x2" LTTY
KK	2" x 1/4 BEND STREET	LL	2" x 45° WYE	MM	3" DBL SAN TEE	NN	1.5" C.O. W/PLUG
OO	2" C.O. W/PLUG	PP	3" C.O. W/PLUG	QQ	2"x2"x1.5" WYE REDUCING	RR	1.5" 1/4 BEND
SS	2"x1.5"x2" SAN TEE	TT	2" P-TRAP	UU	2" x 45° 1/8 BEND STREET	VV	2" COUPLING
WW	3" x 45° 1/8 BEND STREET	XX	2" SANITARY TEE	YY	4" CLOSET FLANGE	ZZ	4" COUPLING
AB	1.5" CONT WASTE	AC	1.5" x 22 1/2° ELBOW STREET	AD	2" x 22 1/2° ELBOW STREET	AE	3"x3"x2"x2" DBL SAN TEE
AF	2"x1.5"x1.5" SAN TEE STREET	AG	2"x1.5"x1.5" 3-WAY ELBOW	AH	3" x 22 1/2° 1/16 BEND ELBOW	AI	1.5" 3-WAY ELBOW
AJ	2" x 22 1/2° 1/16 BEND ELBOW	AK	4"x3" CLOSET BEND STR (CUT DOWN 1.5")	AL	3"x3"x3" WYE	AM	3" 1/4 BEND
AN	2"x3" PIPE INCREASER	AO	3" x 3" x 2" WYE	AH	2" 1/4 BEND	AD	2"x2"x2"x2" DBL SAN TEE
AR	1.5"x3" PIPE INCREASER	AS	1.5"x1.5"x1.5"x1.5" DBL SAN TEE	AT	3" DOUBLE FIXTURE TEE	AP	2"x2"x1.5"x1.5" DBL SAN TEE
AV	3"x3"x2"x2" SAN TEE (SI) LEFT	AW	3"x3"x3"x1.5" SAN TEE (SI) LEFT	AX	3"x3"x3"x2" SAN TEE (SI) LEFT	AY	3"x3"x2"x2" SAN TEE (SI) RIG
AZ	3"x3"x3"x1.5" SAN TEE (SI) RIGHT	BA	3"x3"x3"x2" SAN TEE (SI) RIGHT	BB	3"x3"x3"x2"x2" SAN TEE DBL(SI) D	BC	3"x3"x3"x1.5"x1.5" SAN T DBL
BE	1.5"x2" FITPE INCREASER	BF	3"x3"x1.5" 90° LSWEEP LOW HEEL INLR	BG	3"x3"x2" 90° LSWEEP LOW HEEL INLR	BH	1.5" x 22 1/2° 1/16 BEND ELB
BI	4"x3" CLOSET BEND STREET	BJ		BK		BL	

BRAND	SCHULT
SERIES	GM28
OAKWOOD HOMES CORP.	

REVISIONS	BY	DATE
UTILITY DOOR UNDERCUT FOR RETURN AIR	EXP	07/20/16
CHANGED MBR AND MBR CLOSET TO 3.0 DOORS PER MICHAEL	EXP	06/28/16
ADJUSTED DIMS FLOOR DWV	EXP	06/17/16
CREATED NEW PATRIOT OFF SH247962	EXP	04/08/16

GENERAL NOTES

DRAWING TITLE	DWV SCHEMATIC
---------------	---------------

MODEL NAME	WASHINGTON-MOD	SQ. FT.	1502
PLANT	28X56 3BR-2BA	MODEL NO.	SN251511
DRAWN BY	TXH	DATE PRINTED	12/30/2019
ORIG. DATE	11/14/2019	SHEET NO.	8-1

PIPING AND FITTING MATERIAL TYPE TO BE:  
PEX TYPE BY QUEST, CPVC OR COPPER

PRESSURE RANGE 40-49 PSI  
60' DEVELOPED LENGTH

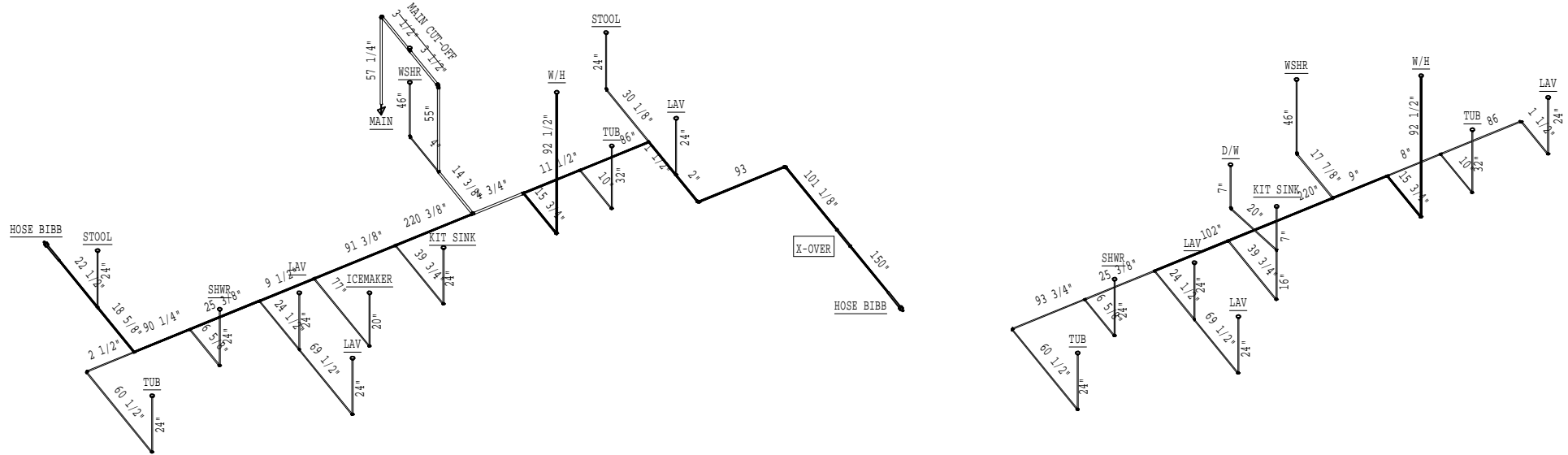

COLD WATER SUPPLY PLUMBING

HOT WATER SUPPLY PLUMBING

PIPE LEGEND

	1"
	3/4"
	1/2"

BRAND	SCHULT
SERIES	GM28
OAKWOOD HOMES CORP.	

REVISIONS	BY	DATE
UTILITY DOOR UNDERCUT FOR RETURN AIR	EXP	07/20/16
CHANGED MBR AND MBR CLOSET TO 3.0 DOORS PER MICHAEL	EXP	06/28/16
ADJUSTED DIMS FLOOR DWV	EXP	06/17/16
CREATED NEW PATRIOT OFF SN247962	EXP	04/08/16

GENERAL NOTES
HOSE BIBBS PER SPECS

DRAWING TITLE	<b>SUPPLY PLUMBING</b>
---------------	------------------------

MODEL NAME	WASHINGTON-MOD		SQ. FT.	1502	
PLANT	958	DESCRIPTION	28X56 3BR-2BA	MODEL NO.	SN251511
DRAWN BY	TXH	ORIG. DATE	11/14/2019	DATE PRINTED	12/30/2019
				SHEET NO.	9-1

SMOKE DETECTORS NOT ALLOWED ON ARC FAULTS IN THE STATE OF SOUTH CAROLINA  
 ALL EXTERIOR LIGHTING MUST BE OF THE WATERPROOF TYPE

NOTE: ALL FAMILY, DINING, LIVING, KITCHEN, LAUNDRY, LIBRARIES, DENS, BEDROOMS, RECREATION ROOMS, CLOSETS, HALLWAYS  
 OR SIMILAR ROOMS OR SPACES SHALL BE PROTECTED BY A LISTED ARC-FAULT CIRCUIT INTERRUPTER IN ACCORDANCE WITH SECTION 210.12 OF THE NEC.

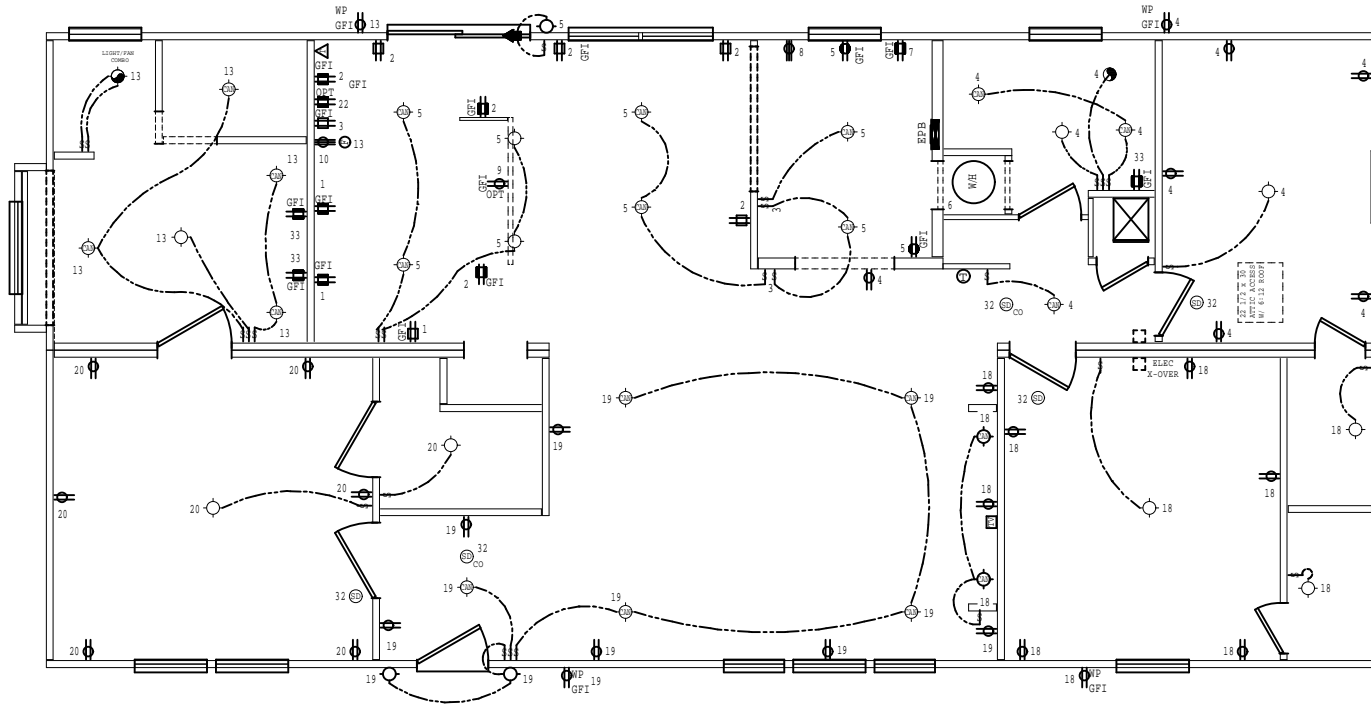

ELECTRICAL SCHEDULE																																																		
CIR. NO.	DESCRIPTION	BRK. AMP.	VOLTS	COPR. WIRE	CIR. NO.	DESCRIPTION	BRK. AMP.	VOLTS	COPR. WIRE	CIR. NO.	DESCRIPTION	BRK. AMP.	VOLTS	COPR. WIRE	CIR. NO.	DESCRIPTION	BRK. AMP.	VOLTS	COPR. WIRE	CIR. NO.	DESCRIPTION	BRK. AMP.	VOLTS	COPR. WIRE																										
1	PORTABLE APPLIANCES	20	120	12	5	GEN. LIGHTING/RECEPT.	15	120	14	8	DRYER RECEPT.	30	240	10	12	ELECTRIC FURNACE	CIRCUITS VARY, SEE	15	120	14	19	GEN. LIGHTING/RECEPT.	15	120	14																									
2	PORTABLE APPLIANCES	20	120	12	6	ELEC. WATER HEATER	CIRCUITS VARY, SEE	9	120	14	9	OPT. DISHWASHER	15	120	14	12	DAFIA PAGE PLM-3.5 FOR HUD, PLM-1.5 FOR MOD	16	120	12	16	OPT. GARAGE DISPOSAL	15	120	14	24	ELECT. BUILT-IN OVEN	20	240	12/3	25	GEN. LIGHTING/RECEPT.	15	120	14	25	GEN. LIGHTING/RECEPT.	15	120	14										
3	PORTABLE APPLIANCES	20	120	12	7	WASHER RECEPT.	20	120	12	10	ELECT. RANGE/CKTOP	40	240	8	13	GEN. LIGHTING/RECEPT.	15	120	14	14	14	OPT. COOLER BOX	15	120	14	17	OPT. WHIRLPOOL	20	120	12	20	GEN. LIGHTING/RECEPT.	15	120	14	26	GEN. LIGHTING/RECEPT.	15	120	14	30	GEN. LIGHTING/RECEPT.	15	120	14					
4	GEN. LIGHTING/RECEPT.	15	120	14	11	GAS FURNACE	15	120	14	11	GAS FURNACE	15	120	14	14	GEN. LIGHTING/RECEPT.	15	120	14	14	14	OPT. MICROWAVE	20	120	12/2	22	GEN. LIGHTING/RECEPT.	15	120	14	27	GEN. LIGHTING/RECEPT.	15	120	14	27	GEN. LIGHTING/RECEPT.	15	120	14	31	SITE INSTALLED HEAT PUMP	40	240	8/3	31	REFRIGERATOR	20	120	1

  

BRAND	SCHULT	SERIES	GM28	REVISIONS	BY	DATE	GENERAL NOTES	DRAWING TITLE	MODEL NAME	SQ. FT.		
				UTILITY DOOR UNDERCUT FOR RETURN AIR	EXP	07/20/16	LOCK-OUT BREAKER ON CIRCUIT #6	<b>ELECTRICAL PLAN</b>	WASHINGTON-MOD	1502		
				CHANGED MBR AND MBR CLOSET TO 3.0 DOORS PER MICHAEL	EXP	06/28/16			PLANT	DESCRIPTION	MODEL NO.	
				ADJUSTED DIMS FLOOR DMV	EXP	06/17/16			958	28X56 3BR-2BA	SN251511	
				CREATED NEW PATRIOT OFF SH247962	EXP	04/08/16			DRAWN BY	ORIG. DATE	DATE PRINTED	SHEET NO.
									TXH	11/14/2019	12/30/2019	11-1

OAKWOOD HOMES CORP.

SW2

A	25	2x4	2	SFF	91 1/2"
B	15	2x4	3	SFF	91 1/2"
C	2	2x4	3	SFF	80 1/2"
D	6	2x4	3	SFF	80 1/4"
E	2	2x4	3	SFF	79 3/4"
F	23	2x4	2	SFF	18 1/2"
G	4	2x4	2	SFF	8 3/4"
H	13	2x4	2	SFF	8 1/4"
I	4	2x4	2	SFF	8"
J	7	2x4	2	SFF	6 1/2"
K	3	2x4	2	SFF	672"
L	8	2x4	3	SFF	39 1/2"
M	2	2x4	3	SFF	39"
N	4	2x4	3	SFF	36 1/2"
O	8	2x4	3	SFF	30 1/2"

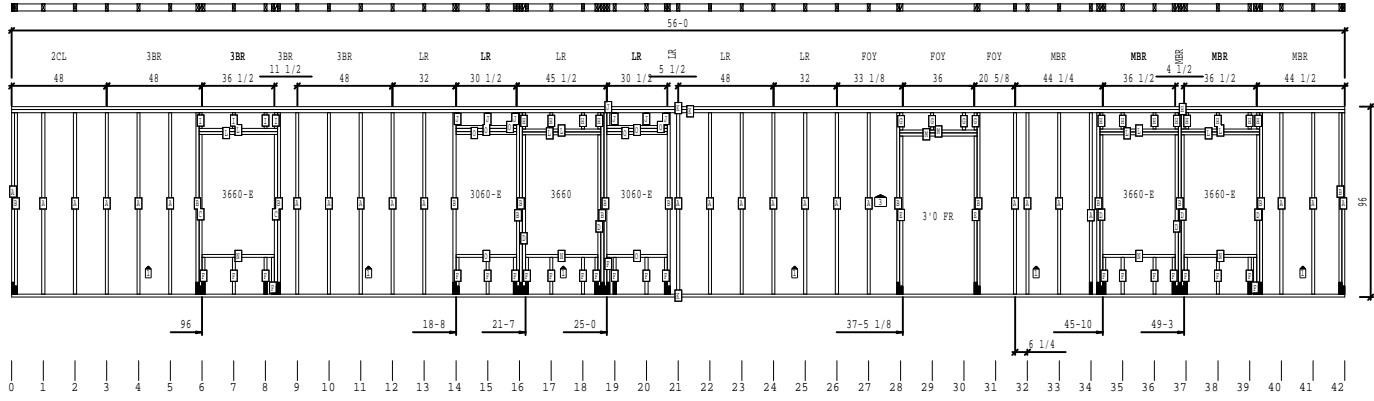

SW1

A	38	2x4	3	SFF	91 1/2"
B	2	2x4	3	SFF	88 3/4"
C	4	2x4	3	SFF	88 1/2"
D	4	2x4	3	SFF	80 3/4"
E	12	2x4	3	SFF	38 3/4"
F	6	2x4	3	SFF	38 3/4"
G	13	2x4	3	SFF	6 1/4"
H	2	2x4	3	SFF	672"
I	1	2x4	3	SFF	382 3/4"
J	1	2x4	3	SFF	249 3/4"
K	3	1x4	3	SFF	91 1/2"
L	3	2x4	2	SFF	75 3/4"
M	3	2x4	2	SFF	75"
N	1	2x4	3	SFF	72 3/4"
O	6	2x4	3	SFF	39 1/2"
P	3	2x4	3	SFF	36 1/2"

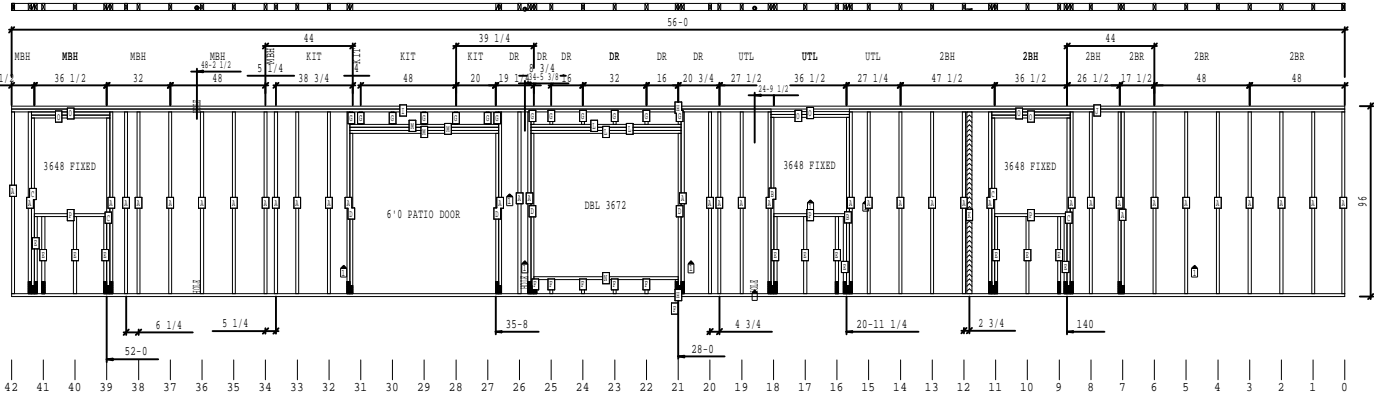

BRAND	SCHULT	SERIES	GM28
OAKWOOD HOMES CORP.			

REVISIONS	BY	DATE

GENERAL NOTES

DRAWING TITLE	SIDEWALLS WIND-100/30#
---------------	---------------------------

MODEL NAME	WASHINGTON-MOD	SQ. FT.	1493
PLANT	958	DESCRIPTION	28X56 3BR-2BA
MODEL NO.	SN251511	DRAWN BY	TXH
DATE PRINTED	12/30/2019	ORIG. DATE	11/14/2019
SHEET NO.	12-100-30-		



### EW1

- A 8 2x4 3 SPP 93"
- B 2 2x4 2 SPP 93"
- C 4 2x4 3 SPP 16 1/2"
- D 4 2x4 3 SPP 13"
- E 2 2x4 3 SPP 156"
- F 1 2x4 3 SPP 36 1/2"
- G 1 2x4 2 SPP 36 1/2"

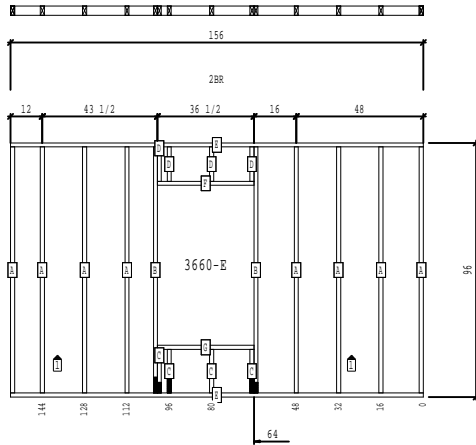

### EW2

- A 11 2x4 3 SPP 93"
- B 2 2x4 3 SPP 156"

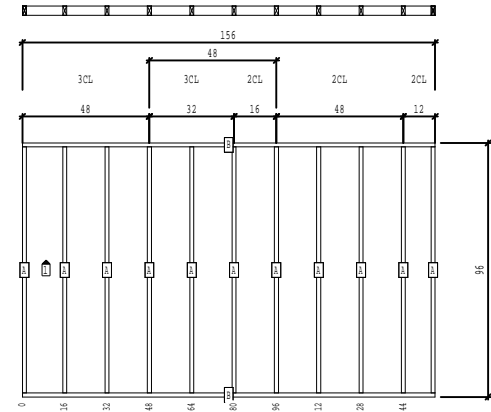

### EW3

- A 13 2x4 2 SPP 93"
- B 5 2x4 2 SPP 6 1/2"
- C 2 2x4 2 SPP 156"
- D 3 2x4 3 SPP 78"

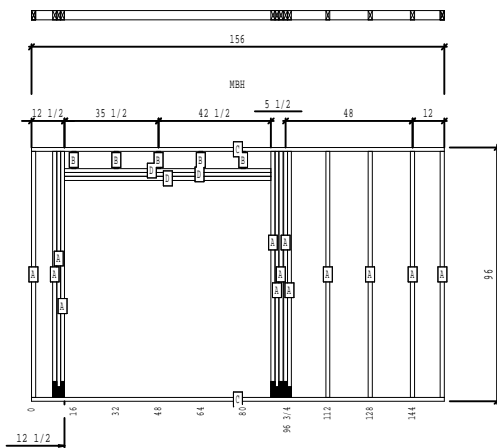

### EW4

- A 11 2x4 3 SPP 93"
- B 2 2x4 3 SPP 156"

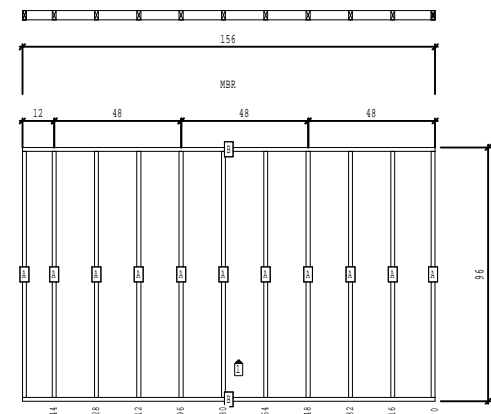

BRAND	SCHULT	SERIES	GM28
OAKWOOD HOMES CORP.			

REVISIONS	BY	DATE

GENERAL NOTES

DRAWING TITLE	<b>ENDWALLS A-UNIT</b> <b>WIND-100/30#</b>
---------------	-----------------------------------------------

MODEL NAME	WASHINGTON-MOD		SQ. FT.	1493	
PLANT	958	DESCRIPTION	28X56 3BR-2BA	MODEL NO.	SN251511
DRAWN BY	TXH	ORIG. DATE	11/14/2019	DATE PRINTED	12/30/2019
				SHEET NO.	14-100-30-

**EW5**

- A 3 2x4 3 SPP 93"
- B 2 2x4 3 SPP 16"

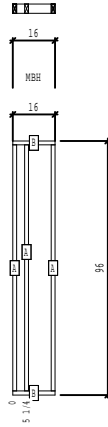

**EW6**

- A 2 2x4 3 SPP 93"
- B 2 2x4 2 SPP 93"
- C 4 2x4 3 SPP 58"
- D 4 2x4 3 SPP 16"
- E 2 2x4 3 SPP 77"
- F 2 2x4 3 SPP 46 1/2"
- G 1 2x4 2 SPP 46 1/2"

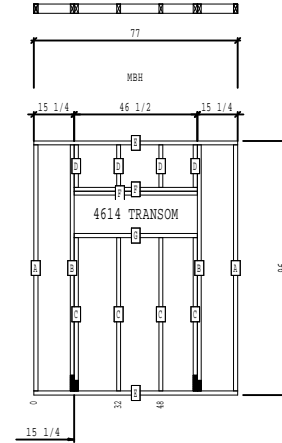

**EW7**

- A 3 2x4 3 SPP 93"
- B 2 2x4 3 SPP 16"

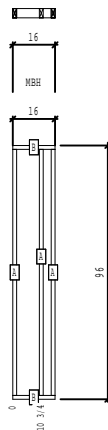

BRAND	SCHULT	SERIES	GM28
OAKWOOD HOMES CORP.			

REVISIONS	BY	DATE

GENERAL NOTES

DRAWING TITLE	<b>ENDWALLS A-UNIT</b> <b>WIND-100/30#</b>
---------------	-----------------------------------------------

MODEL NAME	WASHINGTON-MOD		SQ. FT.	1493
PLANT	DESCRIPTION	MODEL NO.		
958	28X56 3BR-2BA	SN251511		
DRAWN BY	ORIG. DATE	DATE PRINTED	SHEET NO.	
TXH	11/14/2019	12/30/2019	14-100-30-	

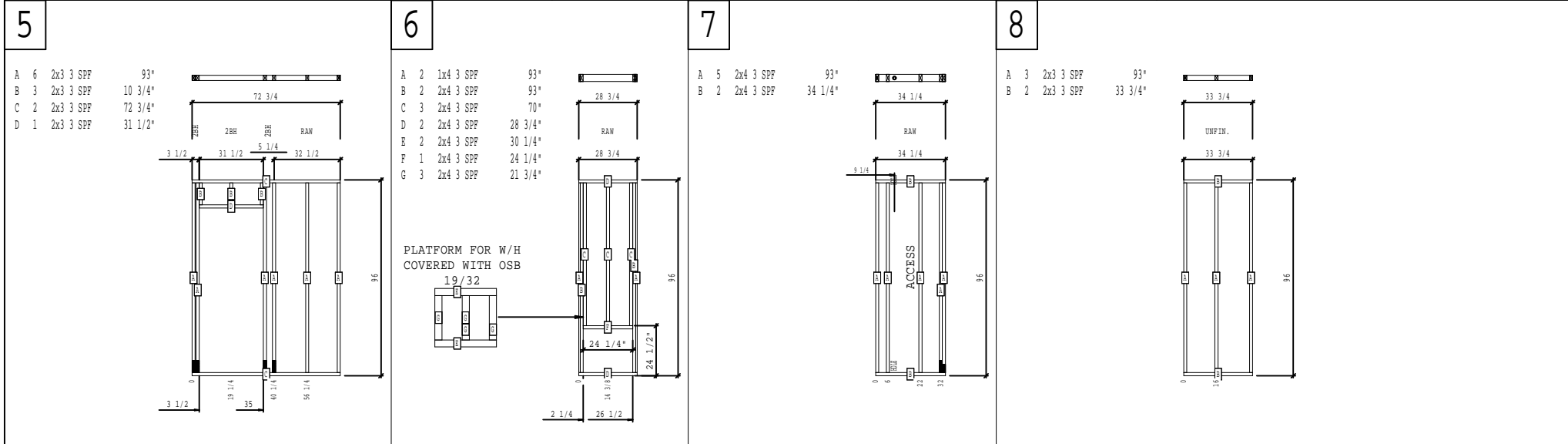
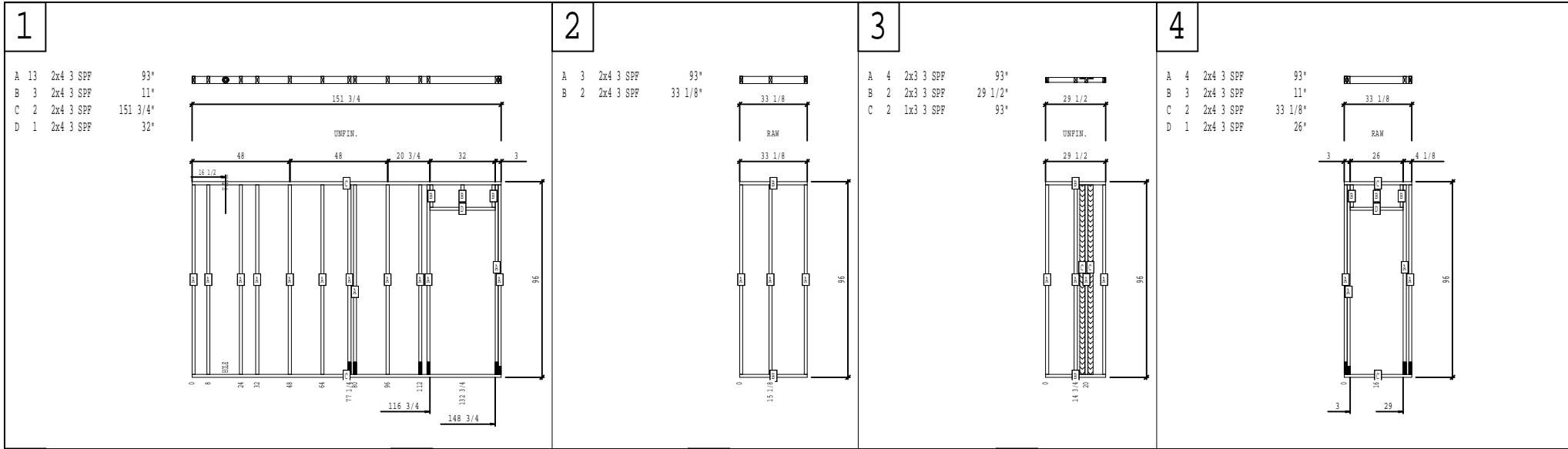

BRAND SCHULT	SERIES GM28	OAKWOOD HOMES CORP.	<table border="1" style="width: 100%; border-collapse: collapse;"> <thead> <tr> <th>REVISIONS</th> <th>BY</th> <th>DATE</th> </tr> </thead> <tbody> <tr> <td>UTILITY DOOR UNDERCUT FOR RETURN AIR</td> <td>EXP</td> <td>07/20/16</td> </tr> <tr> <td>CHANGED MBR AND MBR CLOSET TO 3.0 DOORS PER MICHAEL</td> <td>EXP</td> <td>06/28/16</td> </tr> <tr> <td>ADJUSTED DIMS FLOOR DWG</td> <td>EXP</td> <td>06/17/16</td> </tr> <tr> <td>CREATED NEW PATRIOT OFF SH247962</td> <td>EXP</td> <td>04/08/16</td> </tr> </tbody> </table>	REVISIONS	BY	DATE	UTILITY DOOR UNDERCUT FOR RETURN AIR	EXP	07/20/16	CHANGED MBR AND MBR CLOSET TO 3.0 DOORS PER MICHAEL	EXP	06/28/16	ADJUSTED DIMS FLOOR DWG	EXP	06/17/16	CREATED NEW PATRIOT OFF SH247962	EXP	04/08/16	<table border="1" style="width: 100%; border-collapse: collapse;"> <thead> <tr> <th colspan="2">GENERAL NOTES</th> </tr> </thead> <tbody> <tr> <td colspan="2">1. FOR WEDGE DETAILS, REFER TO TYPICAL DRAWING 21PC-5</td> </tr> </tbody> </table>	GENERAL NOTES		1. FOR WEDGE DETAILS, REFER TO TYPICAL DRAWING 21PC-5		DRAWING TITLE <b>PARTITIONS SHEET - 1</b>	<table border="1" style="width: 100%; border-collapse: collapse;"> <thead> <tr> <th colspan="2">MODEL NAME</th> <th>SQ. FT.</th> </tr> </thead> <tbody> <tr> <td colspan="2">WASHINGTON-MOD</td> <td>1493</td> </tr> </tbody> </table>	MODEL NAME		SQ. FT.	WASHINGTON-MOD		1493
REVISIONS	BY	DATE																													
UTILITY DOOR UNDERCUT FOR RETURN AIR	EXP	07/20/16																													
CHANGED MBR AND MBR CLOSET TO 3.0 DOORS PER MICHAEL	EXP	06/28/16																													
ADJUSTED DIMS FLOOR DWG	EXP	06/17/16																													
CREATED NEW PATRIOT OFF SH247962	EXP	04/08/16																													
GENERAL NOTES																															
1. FOR WEDGE DETAILS, REFER TO TYPICAL DRAWING 21PC-5																															
MODEL NAME		SQ. FT.																													
WASHINGTON-MOD		1493																													
					<table border="1" style="width: 100%; border-collapse: collapse;"> <thead> <tr> <th>PLANT</th> <th>DESCRIPTION</th> <th>MODEL NO.</th> </tr> </thead> <tbody> <tr> <td>958</td> <td>28X56 3BR-2BA</td> <td>SN251511</td> </tr> </tbody> </table>		PLANT	DESCRIPTION	MODEL NO.	958	28X56 3BR-2BA	SN251511																			
PLANT	DESCRIPTION	MODEL NO.																													
958	28X56 3BR-2BA	SN251511																													
					<table border="1" style="width: 100%; border-collapse: collapse;"> <thead> <tr> <th>DRAWN BY</th> <th>ORIG. DATE</th> <th>DATE PRINTED</th> <th>SHEET NO.</th> </tr> </thead> <tbody> <tr> <td>TXH</td> <td>11/14/2019</td> <td>12/30/2019</td> <td>15-1</td> </tr> </tbody> </table>		DRAWN BY	ORIG. DATE	DATE PRINTED	SHEET NO.	TXH	11/14/2019	12/30/2019	15-1																	
DRAWN BY	ORIG. DATE	DATE PRINTED	SHEET NO.																												
TXH	11/14/2019	12/30/2019	15-1																												

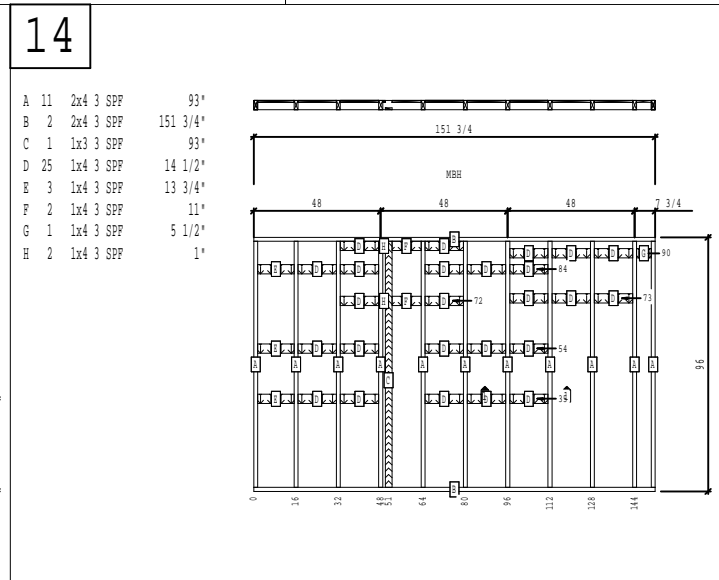
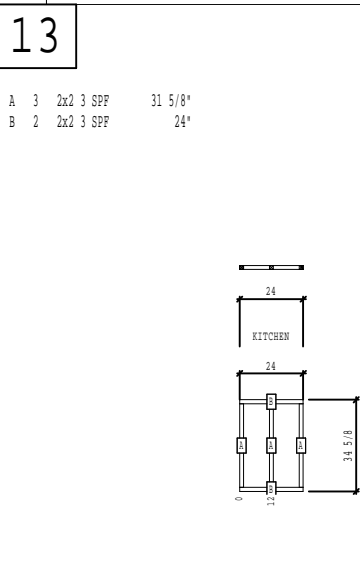
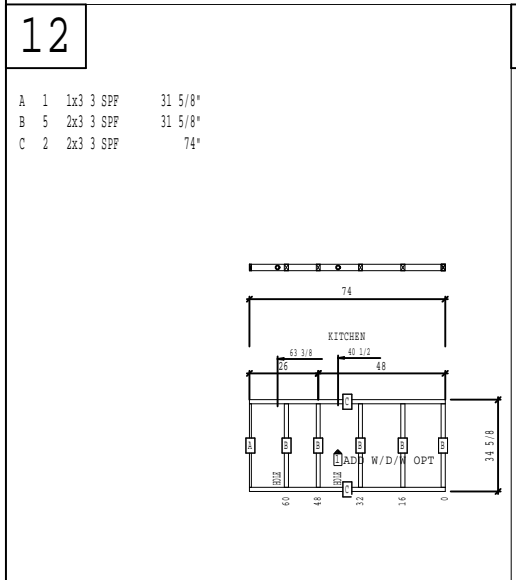
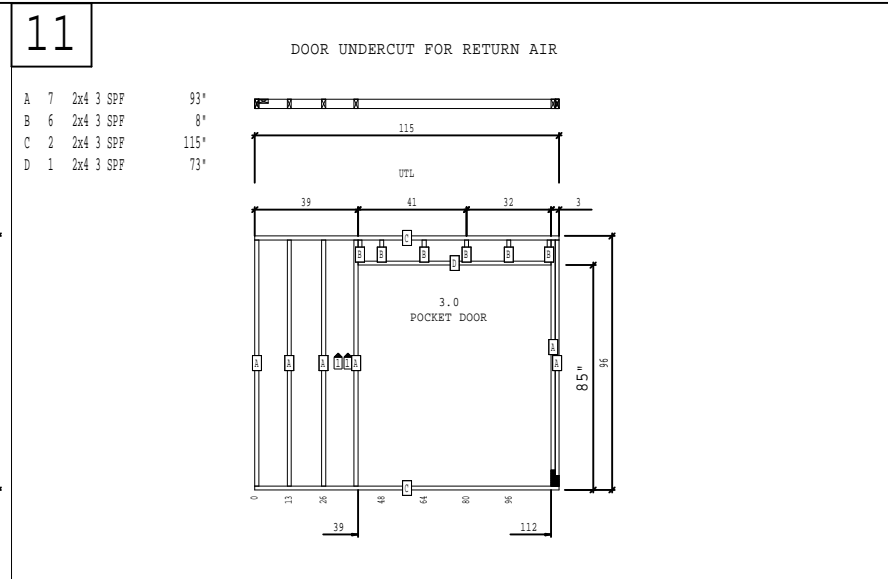
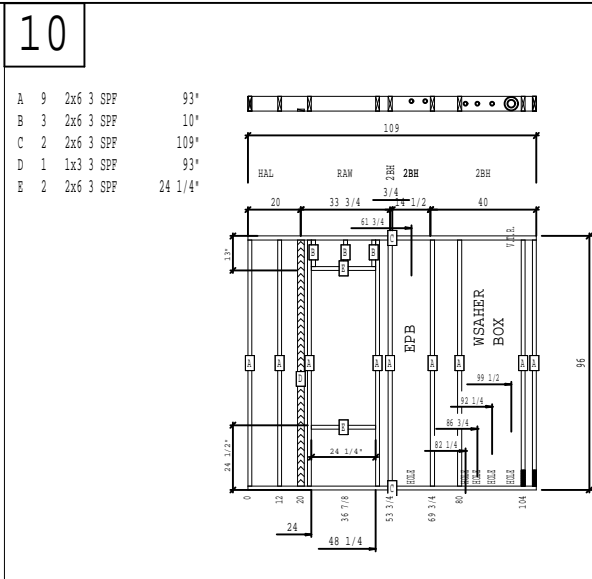
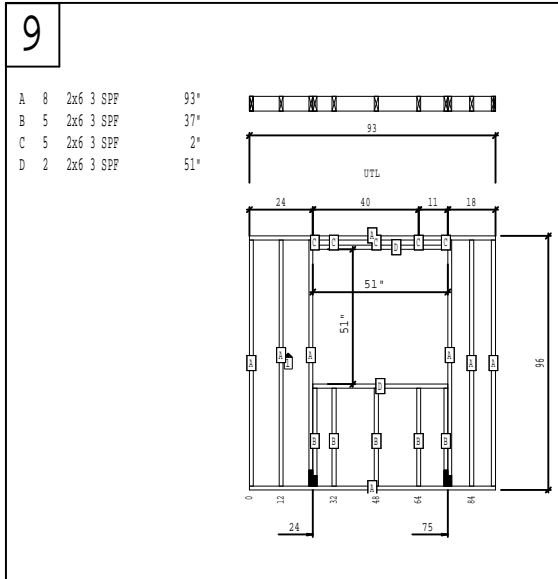

BRAND SCHULT	SERIES GM28	OAKWOOD HOMES CORP.		<table border="1"> <thead> <tr> <th>REVISIONS</th> <th>BY</th> <th>DATE</th> </tr> </thead> <tbody> <tr> <td>UTILITY DOOR UNDERCUT FOR RETURN AIR</td> <td>EXP</td> <td>07/20/16</td> </tr> <tr> <td>CHANGED MBR AND MBR CLOSET TO 3.0 DOORS PER MICHAEL</td> <td>EXP</td> <td>06/28/16</td> </tr> <tr> <td>ADJUSTED DIMS FLOOR DWG</td> <td>EXP</td> <td>06/17/16</td> </tr> <tr> <td>CREATED NEW PATRIOT OFF SH247962</td> <td>EXP</td> <td>04/08/16</td> </tr> </tbody> </table>	REVISIONS	BY	DATE	UTILITY DOOR UNDERCUT FOR RETURN AIR	EXP	07/20/16	CHANGED MBR AND MBR CLOSET TO 3.0 DOORS PER MICHAEL	EXP	06/28/16	ADJUSTED DIMS FLOOR DWG	EXP	06/17/16	CREATED NEW PATRIOT OFF SH247962	EXP	04/08/16	<table border="1"> <thead> <tr> <th>GENERAL NOTES</th> </tr> </thead> <tbody> <tr> <td>1. FOR WEDGE DETAILS, REFER TO TYPICAL DRAWING 21PC-5</td> </tr> </tbody> </table>	GENERAL NOTES	1. FOR WEDGE DETAILS, REFER TO TYPICAL DRAWING 21PC-5	DRAWING TITLE <b>PARTITIONS SHEET - 2</b>	<table border="1"> <thead> <tr> <th>MODEL NAME</th> <th>SQ. FT.</th> </tr> </thead> <tbody> <tr> <td>WASHINGTON-MOD</td> <td>1493</td> </tr> </tbody> </table>	MODEL NAME	SQ. FT.	WASHINGTON-MOD	1493
REVISIONS	BY	DATE																										
UTILITY DOOR UNDERCUT FOR RETURN AIR	EXP	07/20/16																										
CHANGED MBR AND MBR CLOSET TO 3.0 DOORS PER MICHAEL	EXP	06/28/16																										
ADJUSTED DIMS FLOOR DWG	EXP	06/17/16																										
CREATED NEW PATRIOT OFF SH247962	EXP	04/08/16																										
GENERAL NOTES																												
1. FOR WEDGE DETAILS, REFER TO TYPICAL DRAWING 21PC-5																												
MODEL NAME	SQ. FT.																											
WASHINGTON-MOD	1493																											
<table border="1"> <thead> <tr> <th>PLANT</th> <th>DESCRIPTION</th> <th>MODEL NO.</th> </tr> </thead> <tbody> <tr> <td>958</td> <td>28X56 3BR-2BA</td> <td>SN251511</td> </tr> </tbody> </table>		PLANT	DESCRIPTION	MODEL NO.	958	28X56 3BR-2BA	SN251511	<table border="1"> <thead> <tr> <th>DRAWN BY</th> <th>ORIG. DATE</th> <th>DATE PRINTED</th> <th>SHEET NO.</th> </tr> </thead> <tbody> <tr> <td>TXH</td> <td>11/14/2019</td> <td>12/30/2019</td> <td>15-2</td> </tr> </tbody> </table>	DRAWN BY	ORIG. DATE	DATE PRINTED	SHEET NO.	TXH	11/14/2019	12/30/2019	15-2												
PLANT	DESCRIPTION	MODEL NO.																										
958	28X56 3BR-2BA	SN251511																										
DRAWN BY	ORIG. DATE	DATE PRINTED	SHEET NO.																									
TXH	11/14/2019	12/30/2019	15-2																									



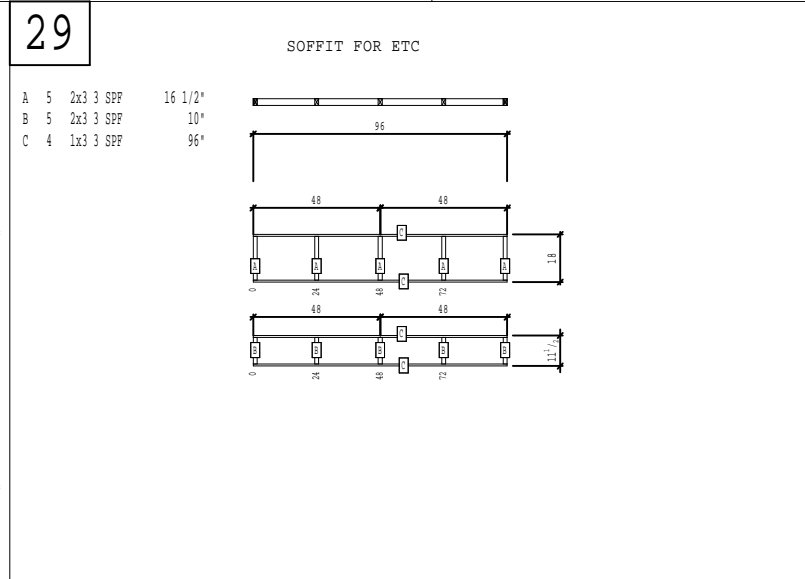
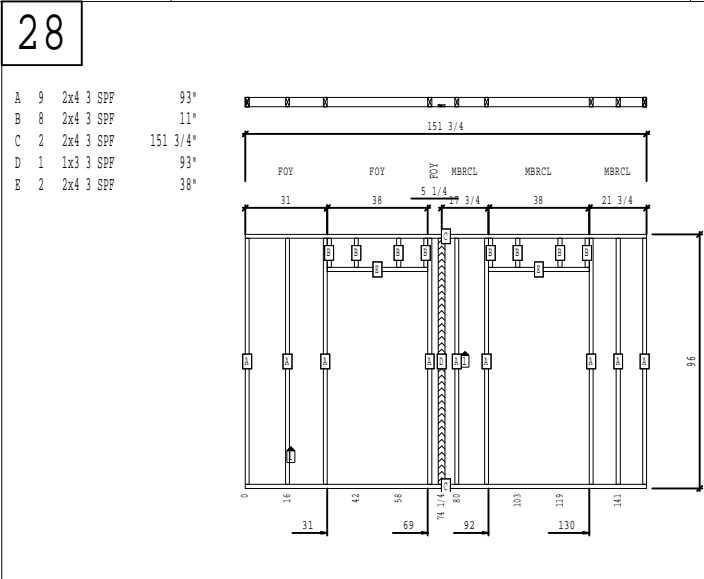
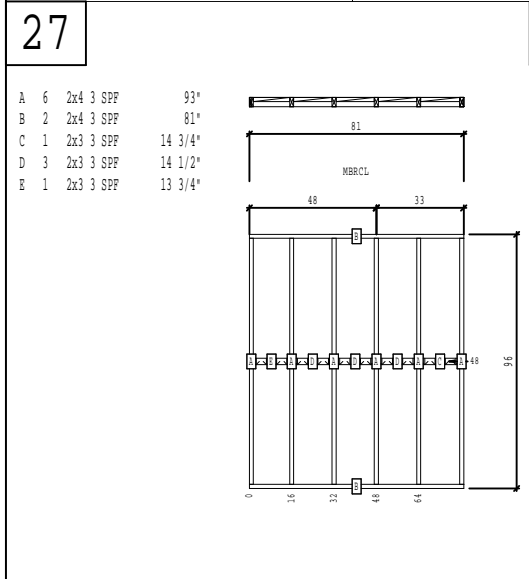
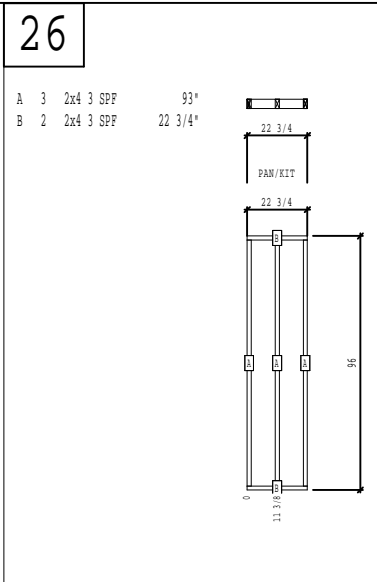
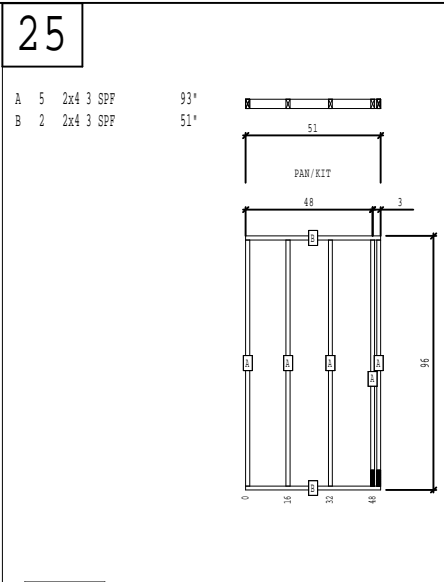
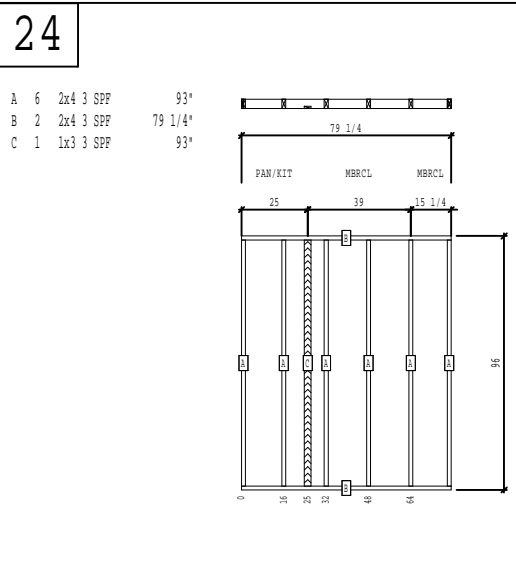
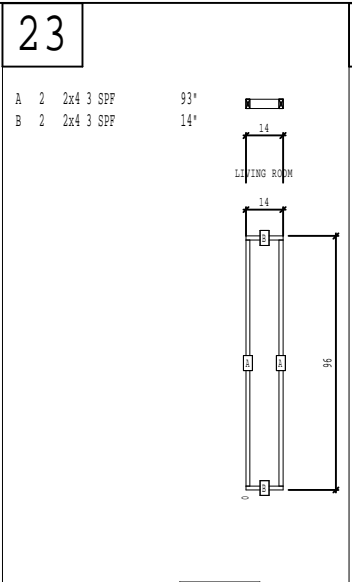
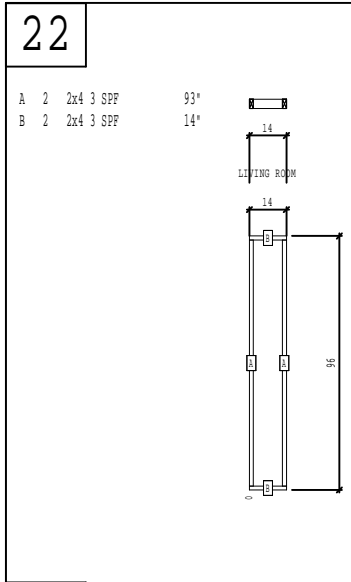

BRAND	SCHULT	SERIES	GM28
OAKWOOD HOMES CORP.			

REVISIONS	BY	DATE
UTILITY DOOR UNDERCUT FOR RETURN AIR	EXP	07/20/16
CHANGED MBR AND MBR CLOSET TO 3.0 DOORS PER MICHAEL	EXP	06/28/16
ADJUSTED DIMS FLOOR DWG	EXP	06/17/16
CREATED NEW PATRIOT OFF SH247962	EXP	04/08/16

GENERAL NOTES
1. FOR WEDGE DETAILS, REFER TO TYPICAL DRAWING 21PC-5

DRAWING TITLE	<b>PARTITIONS SHEET - 4</b>
---------------	---------------------------------

MODEL NAME	WASHINGTON-MOD		SQ. FT.	1493
PLANT	DESCRIPTION	MODEL NO.		
958	28X56 3BR-2BA	SN251511		
DRAWN BY	ORIG. DATE	DATE PRINTED	SHEET NO.	
TXH	11/14/2019	12/30/2019	15-4	



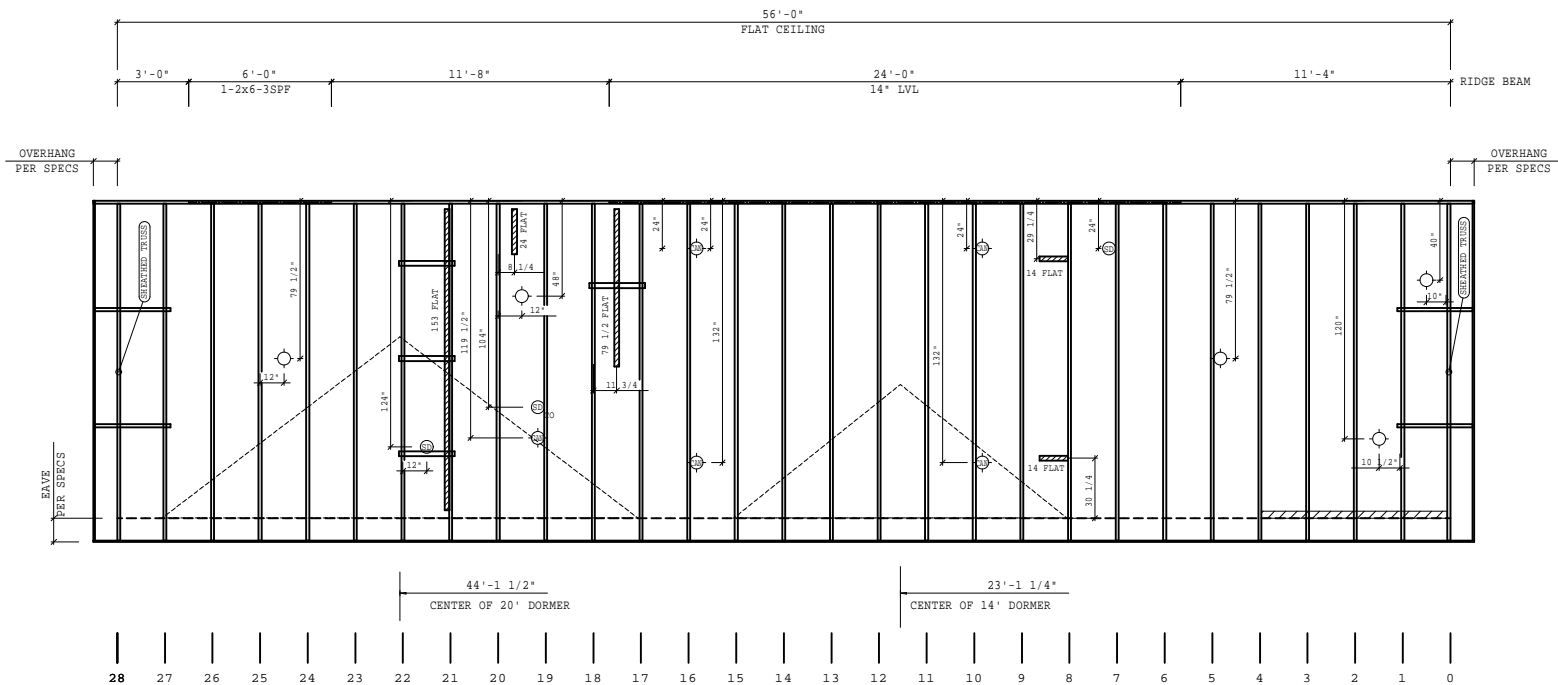

BRAND	SCHULT	SERIES	GM28
OAKWOOD HOMES CORP.			

REVISIONS	BY	DATE
UTILITY DOOR UNDERCUT FOR RETURN AIR	EXP	07/20/16
CHANGED MBR AND MBR CLOSET TO 3.0 DOORS PER MICHAEL	EXP	06/28/16
ADJUSTED DIMS FLOOR DWG	EXP	06/17/16
CREATED NEW PATRIOT OFF SN247962	EXP	04/08/16

GENERAL NOTES
ALL BRIDGE BLOCKS SHOULD BE 26" LONG +/- 1/4" UNLESS OFF MOD
TRUSSES DICTATE LENGTHS TO BE DIFFERENT
*****REPRESENT NO SPLICES IN EDGE RAIL(B=BOTTOM/T=TOP)

DRAWING TITLE	24 O.C. ROOF-B
---------------	----------------

MODEL NAME	WASHINGTON-MOD	SQ. FT.	1493
PLANT	958	DESCRIPTION	28X56 3BR-2BA
MODEL NO.	SN251511	DATE PRINTED	12/30/2019
DRAWN BY	TXH	ORIG. DATE	11/14/2019
SHEET NO.	16-1B		





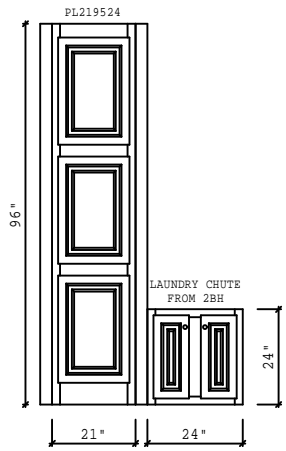

CABINET ELEVATION G  
PANTRY/LAUNDRY CHUTE 2BH

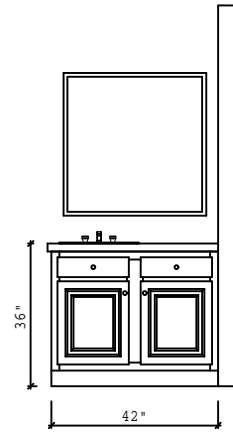

CABINET ELEVATION H  
2BH VANITY

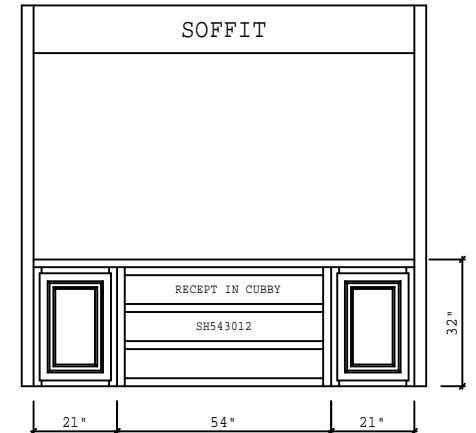

CABINET ELEVATION I  
ETC

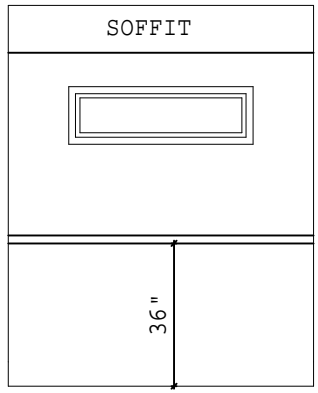

CABINET ELEVATION J  
BEHIND MBH TUB

BRAND	SCHULT	SERIES	GM28
OAKWOOD HOMES CORP.			

REVISIONS	BY	DATE
UTILITY DOOR UNDERCUT FOR RETURN AIR	EXP	07/20/16
CHANGED MBR AND MBR CLOSET TO 3.0 DOORS PER MICHAEL	EXP	06/28/16
ADJUSTED DIMS FLOOR DWV	EXP	06/17/16
CREATED NEW PATRIOT OFF SN247962	EXP	04/08/16

GENERAL NOTES
CAB TRIM, MIRROR TRIM & MIRROR FASTENING PER SPECS

DRAWING TITLE	CABINET ELEVATION-2
---------------	---------------------

MODEL NAME	WASHINGTON-MOD	SQ. FT.	1493
PLANT	958	DESCRIPTION	28X56 3BR-2BA
MODEL NO.	SN251511	DRAWN BY	TXH
ORIG. DATE	11/14/2019	DATE PRINTED	12/30/2019
SHEET NO.	18-2		

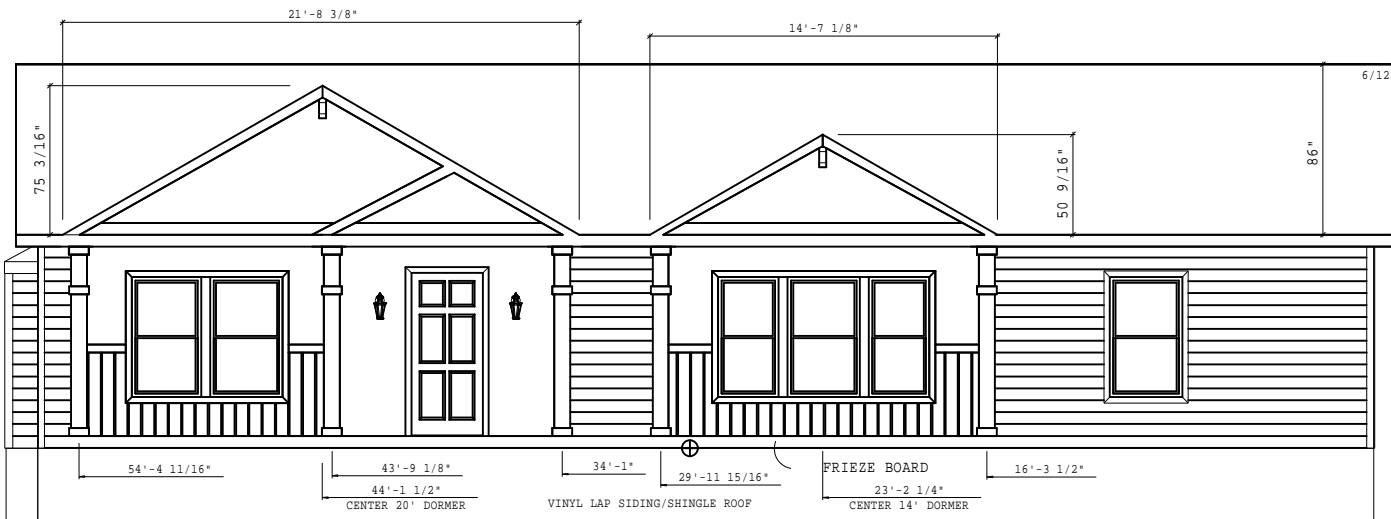

1502 SQ. FT. ATTIC AREA  
 717 SQ. IN. REQUIRED  
 VENTED SOFFIT - 7.38 SQ. IN. VENT/FT  
 50 FT RIDGE CAP/VENT-18.00 SQ. IN. VENT/FT  
 826 SQ. IN. PROVIDED FOR SOFFIT  
 900 SQ. IN. PROVIDED FOR RIDGE VENT

**FRONT ELEVATION**

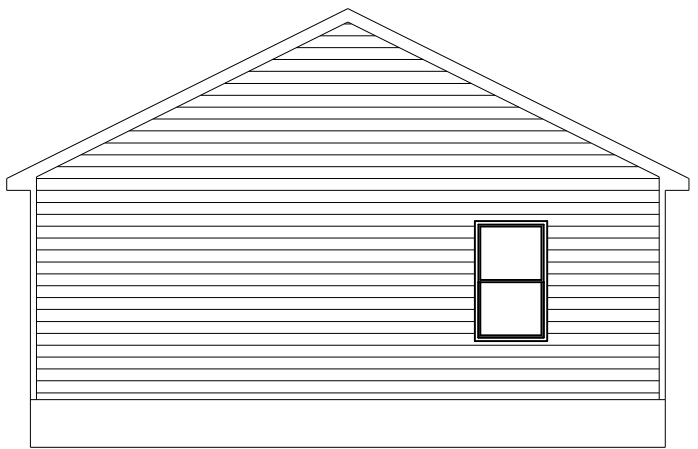

**RIGHT SIDE ELEVATION**

BRAND	SCHULT	SERIES	GM28	REVISIONS		BY	DATE	GENERAL NOTES		DRAWING TITLE	MODEL NAME	SQ. FT.	
OAKWOOD HOMES CORP.				UTILITY DOOR UNDERCUT FOR RETURN AIR	EXP	07/20/16				<b>EXTERIOR ELEVATION FRONT &amp; RIGHT SIDE</b>	WASHINGTON-MOD	1502	
				CHANGED MBR AND MBR CLOSET TO 3.0 DOORS PER MICHAEL	EXP	06/28/16					PLANT	DESCRIPTION	MODEL NO.
				ADJUSTED DIMS FLOOR DWV	EXP	06/17/16					958	28X56 3BR-2BA	SN251511
				CREATED NEW PATRIOT OFF SN247962	EXP	04/08/16					DRAWN BY	ORIG. DATE	DATE PRINTED
										TXH	11/14/2019	12/30/2019	20-1

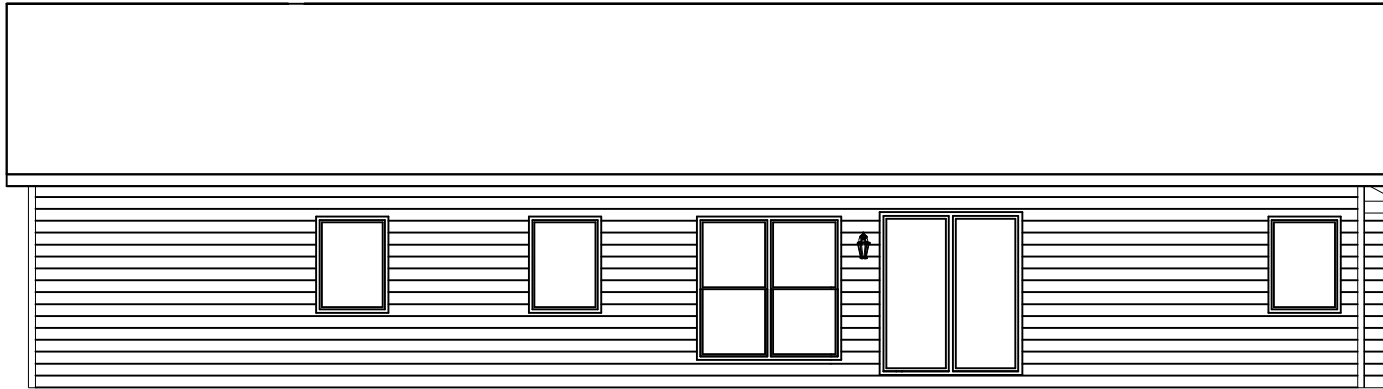

*BACK ELEVATION*

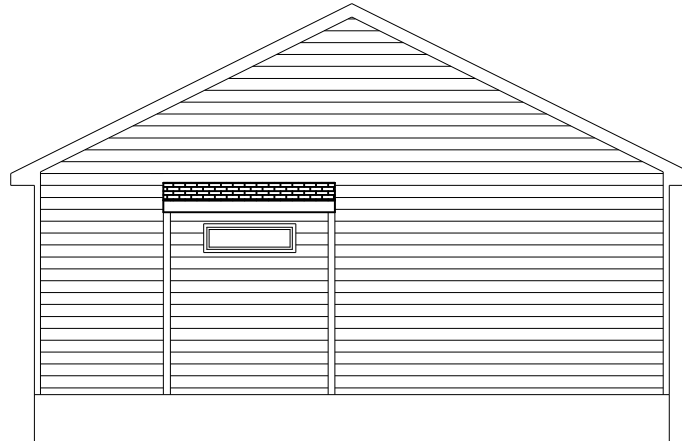

*LEFT SIDE ELEVATION*

BRAND SCHULT	SERIES GM28	<table border="1"> <thead> <tr> <th>REVISIONS</th> <th>BY</th> <th>DATE</th> </tr> </thead> <tbody> <tr> <td>UTILITY DOOR UNDERCUT FOR RETURN AIR</td> <td>EXP</td> <td>07/20/16</td> </tr> <tr> <td>CHANGED MBR AND MBR CLOSET TO 3.0 DOORS PER MICHAEL</td> <td>EXP</td> <td>06/28/16</td> </tr> <tr> <td>ADJUSTED DIMS FLOOR DWV</td> <td>EXP</td> <td>06/17/16</td> </tr> <tr> <td>CREATED NEW PATRIOT OFF SN247962</td> <td>EXP</td> <td>04/08/16</td> </tr> </tbody> </table>		REVISIONS	BY	DATE	UTILITY DOOR UNDERCUT FOR RETURN AIR	EXP	07/20/16	CHANGED MBR AND MBR CLOSET TO 3.0 DOORS PER MICHAEL	EXP	06/28/16	ADJUSTED DIMS FLOOR DWV	EXP	06/17/16	CREATED NEW PATRIOT OFF SN247962	EXP	04/08/16	<table border="1"> <thead> <tr> <th>GENERAL NOTES</th> </tr> </thead> <tbody> <tr> <td> </td> </tr> </tbody> </table>	GENERAL NOTES		<table border="1"> <thead> <tr> <th>DRAWING TITLE</th> </tr> </thead> <tbody> <tr> <td><b>EXTERIOR ELEVATION BACK &amp; LEFT SIDE</b></td> </tr> </tbody> </table>	DRAWING TITLE	<b>EXTERIOR ELEVATION BACK &amp; LEFT SIDE</b>	<table border="1"> <thead> <tr> <th colspan="2">MODEL NAME</th> <th>SQ. FT.</th> </tr> </thead> <tbody> <tr> <td colspan="2">WASHINGTON-MOD</td> <td>1502</td> </tr> </tbody> </table>	MODEL NAME		SQ. FT.	WASHINGTON-MOD		1502
REVISIONS	BY	DATE																													
UTILITY DOOR UNDERCUT FOR RETURN AIR	EXP	07/20/16																													
CHANGED MBR AND MBR CLOSET TO 3.0 DOORS PER MICHAEL	EXP	06/28/16																													
ADJUSTED DIMS FLOOR DWV	EXP	06/17/16																													
CREATED NEW PATRIOT OFF SN247962	EXP	04/08/16																													
GENERAL NOTES																															
DRAWING TITLE																															
<b>EXTERIOR ELEVATION BACK &amp; LEFT SIDE</b>																															
MODEL NAME		SQ. FT.																													
WASHINGTON-MOD		1502																													
OAKWOOD HOMES CORP.		<table border="1"> <thead> <tr> <th>PLANT</th> <th>DESCRIPTION</th> <th>MODEL NO.</th> </tr> </thead> <tbody> <tr> <td>958</td> <td>28X56 3BR-2BA</td> <td>SN251511</td> </tr> </tbody> </table>	PLANT	DESCRIPTION	MODEL NO.	958	28X56 3BR-2BA	SN251511	<table border="1"> <thead> <tr> <th>DRAWN BY</th> <th>ORIG. DATE</th> <th>DATE PRINTED</th> <th>SHEET NO.</th> </tr> </thead> <tbody> <tr> <td>TXH</td> <td>11/14/2019</td> <td>12/30/2019</td> <td>20-2</td> </tr> </tbody> </table>	DRAWN BY	ORIG. DATE	DATE PRINTED	SHEET NO.	TXH	11/14/2019	12/30/2019	20-2														
PLANT	DESCRIPTION	MODEL NO.																													
958	28X56 3BR-2BA	SN251511																													
DRAWN BY	ORIG. DATE	DATE PRINTED	SHEET NO.																												
TXH	11/14/2019	12/30/2019	20-2																												

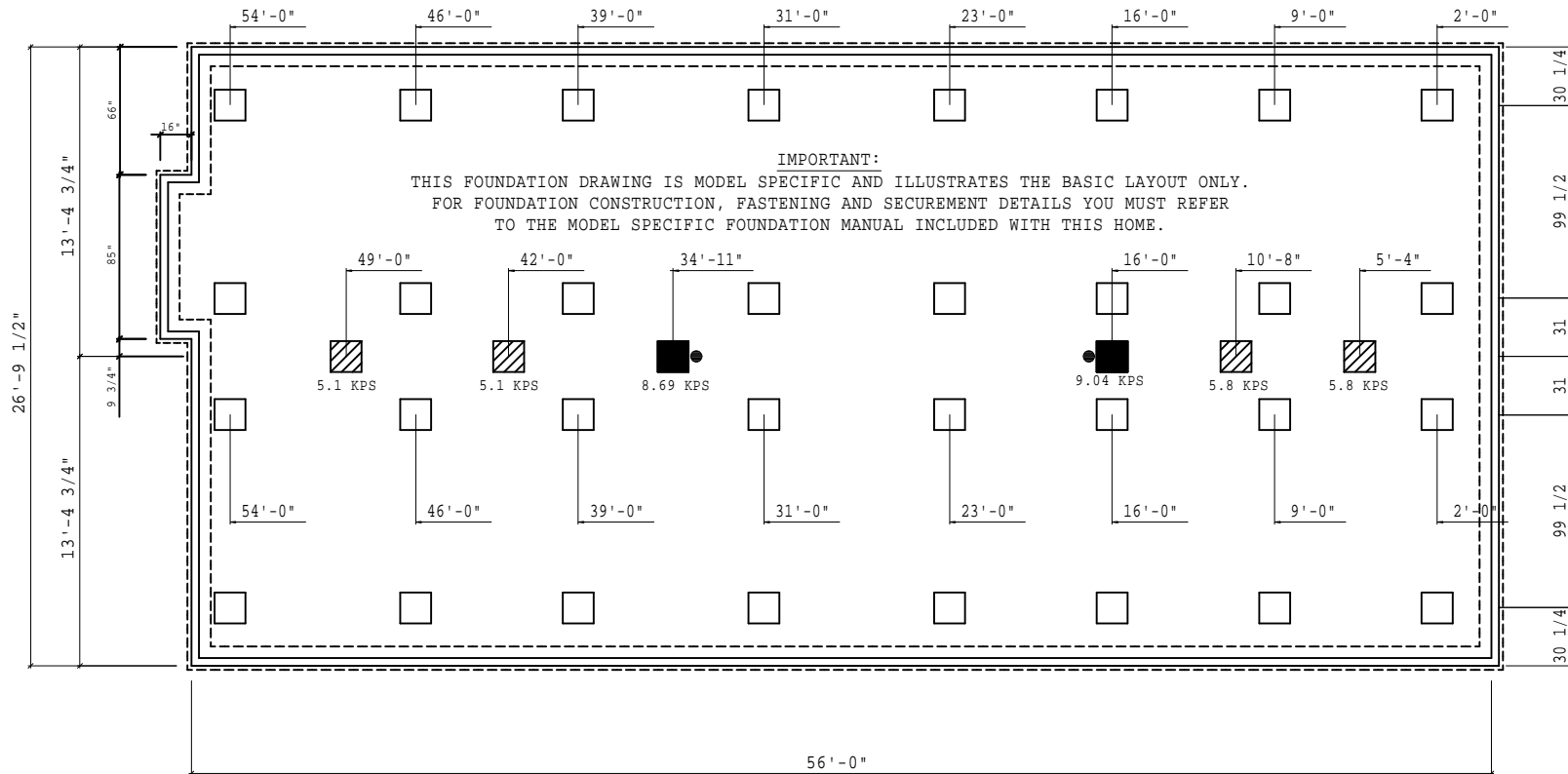

● NOTES MARRIAGE WALL TIE DOWNS  
PER TABLE M AND DETAIL D6 IN THE FOUNDATION PACKAGE

NOTE: THE OVERALL FOUNDATION WIDTH SHOWN  
IS 1 1/2" LARGER THAN THE ACTUAL FLOOR WIDTH  
TO COMPENSATE FOR PRODUCTION AND ASSEMBLY TOLERANCES.

PIER LEGEND	
	= SUPPORT AT MATING COLUMN
	= SUPPORT UNDER MATING WALL
	= SUPPORT UNDER MATING OPENING
	= SUPPORT AT PORCH/RECESSED ENTRY
	= SUPPORT UNDER MAIN I-BEAM
	= SUPPORT UNDER PERIMETER WALL
	= SUPPORT AT CROSS I-BEAM BASEMENT

CRAWLSPACE VENTILATION  
VENTILATION IS BASED ON 144 SQ. IN. OF VENT FOR EVERY 150 SQ. FT.  
OF CRAWLSPACE AREA WITH APPROVED VAPOR RETARDER MATERIAL. ONE SUCH  
VENT MUST BE WITHIN 3 FT. OF EACH CORNER

1493 SQ. FT. OF CRAWLSPACE AREA  
1434 SQ. IN. OF VENT REQUIRED  
28 VENTS NEEDED @ 52 SQ. IN. EACH  
1456 SQ. IN. VENTILATION INSTALLED MINIMUM

CRAWL SPACE  
18" MIN CLEARANCE BELOW BOTTOM OF  
FLOOR JOIST. GROUND TO BE COVERED  
WITH APPROVED VAPOR RETARDER MATERIAL.

INSTALL SWITCHED LIGHT AND GFCI  
RECEPT AT CRAWL SPACE ENTRANCE  
FOR SERVICE OF MECHANICAL  
EQUIPMENT PER NEC - 210-70 (C)

NOTE: MASONRY UNITS FOR STAND ALONE PIERS SHALL BE LAID IN TYPE 'M' OR 'S' MORTAR OR SHALL BE COVERED WITH SURFACE  
BONDING CEMENT COMPLYING WITH ASTM C 887 WHEN ACCEPTABLE TO LOCAL BUILDING AUTHORITY.  
SURFACE BONDING CEMENT SHALL BE APPLIED IN STRICT COMPLIANCE OF MANUFACTURERS INSTRUCTIONS.  
BOTTOM COURSE SHALL BE LAID IN TYPES 'M' OR 'S' MORTAR OR BONDING MORTAR (CEMENT).

NOTE: THE FOUNDATION WIDTH SHOWN 26'-8"  
IS IDENTICAL TO THE OVERALL FLOOR WIDTH OF THE HOME  
THE FOUNDATION MAY BE CONSTRUCTED UP TO 1 1/2" WIDER  
TO COMPENSATE FOR PRODUCTION AND ASSEMBLY TOLERANCE.

BRAND	SCHULT
SERIES	GM28
OAKWOOD HOMES CORP.	

REVISIONS	BY	DATE

GENERAL NOTES

SEE INSTALLATION MANUAL FOR FOUNDATION GENERAL NOTES & TIE-DOWN  
REQUIREMENTS

FOUNDATION VENT LOCATIONS ARE SHOWN TYPICAL & ARE SUBJECT TO CHANGE  
DUO TO PIER LOCATION, CHASSIS MEMBERS & EXTERIOR DECK INSTALLATION  
( ) - DIMENSIONS DENOTES 2X6 WALLS OPTION

DRAWING TITLE

**20/30 PSF  
PIER SET**

MODEL NAME		WASHINGTON-MOD	SQ. FT.
			1493
PLANT	DESCRIPTION	MODEL NO.	
958	28X56 3BR-2BA	SN251511	
DRAWN BY	ORIG. DATE	DATE PRINTED	SHEET NO.
TXH	11/14/2019	12/30/2019	21-PS