

- 4/0-4/0-4/0-2/0 Aluminum FSE Cable
- 60-foot Run to Main Panel
  - Buried 18"
  - 2" PVC Piping

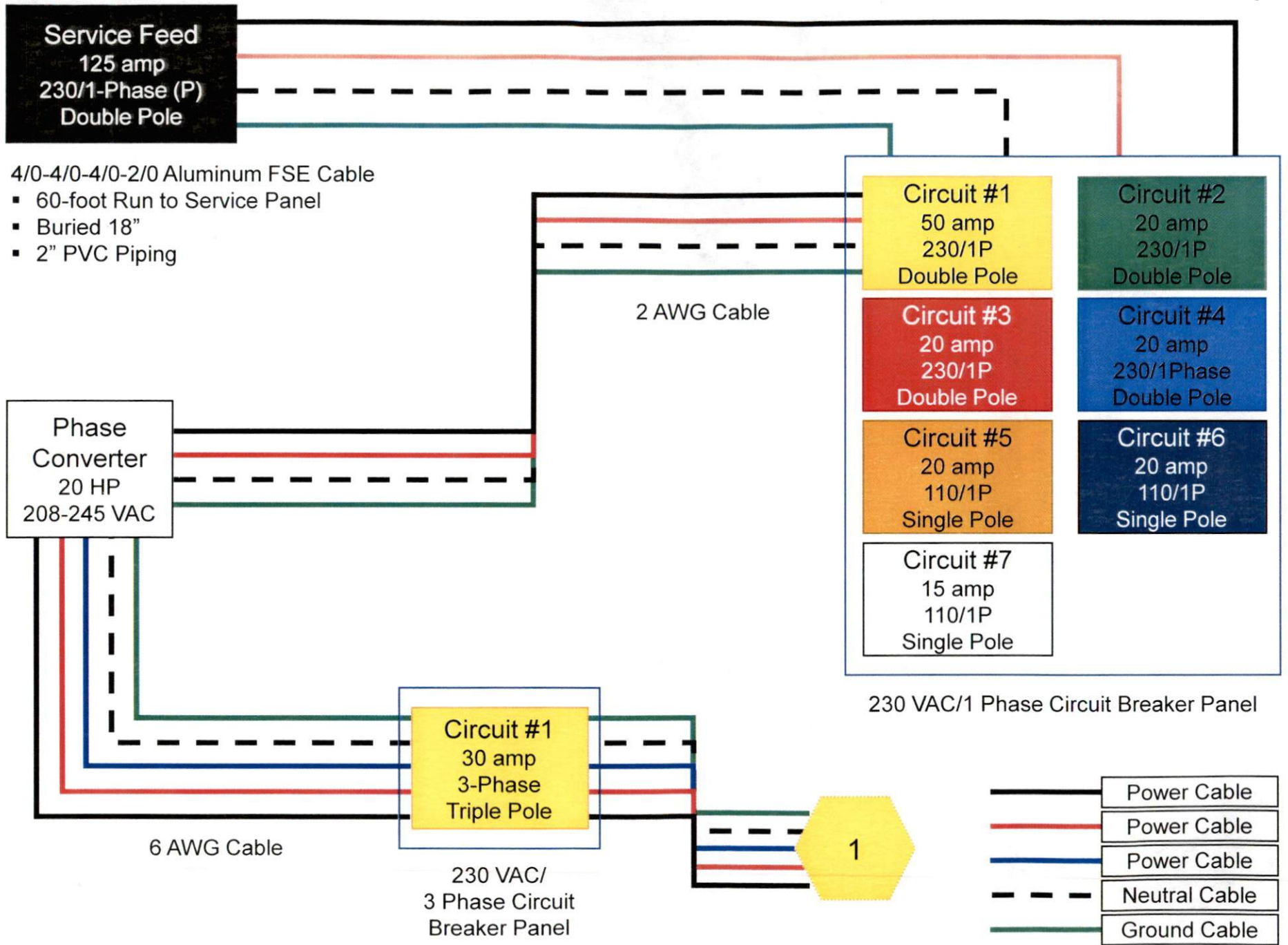

14/2 For 15 amp  
 12/2 For 20 amp

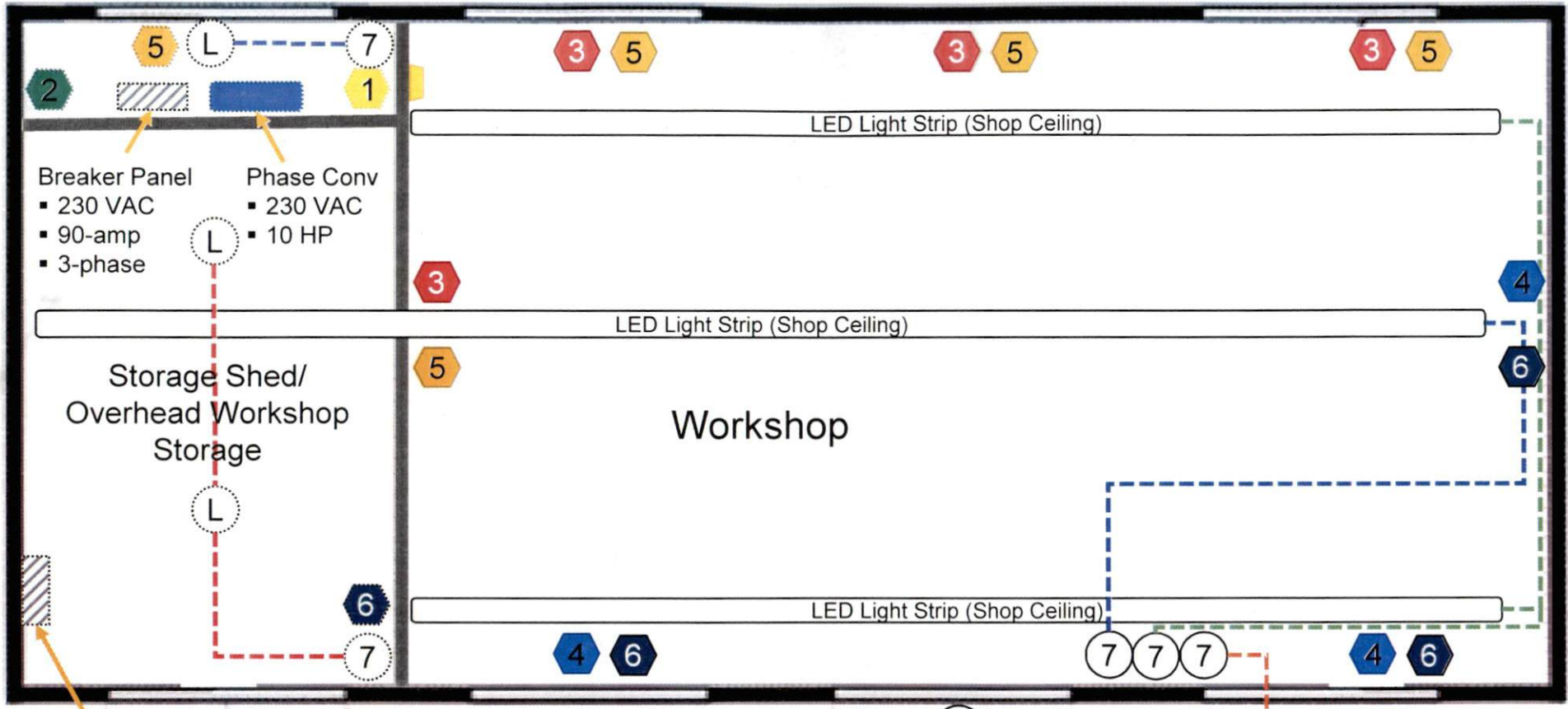

- Breaker Panel**
- 230 VAC
  - 90-amp
  - 3-phase

- Phase Conv**
- 230 VAC
  - 10 HP

Storage Shed/  
Overhead Workshop  
Storage

Workshop

LED Light Strip (Shop Ceiling)

LED Light Strip (Shop Ceiling)

LED Light Strip (Shop Ceiling)

- Breaker Panel**
- 230 VAC
  - 125-amp
  - 24-circuit
  - 1-phase
  - Main lug
  - Ground bars (2)
  - UNSPSC 39121100

- N** (7) Circuit Identifiers
- L** Lights

- F** Fusible Metallic Safety Switch
- Circuit #1
  - Siemens
  - 30-amp
  - 3-phase
  - UNSPSC 39121500