



STRUCTURAL DESIGN ENCLOSED BUILDING

**MAXIMUM 30'-0" WIDE X 20'-0" EAVE HEIGHT- BOX EAVE
FRAME**

**14 December 2018
Revision 7**

M&A Project No. 16062S/16155S/16207S/17155S/17200S/18068S/18156S/18290S

Prepared for:

**Steel Buildings and Structures, Inc.
P.O. Box 1287
Mt. Airy, NC 27030**

Prepared by:

**Moore and Associates Engineering
and Consulting, Inc.**

**1009 East Avenue
North Augusta, SC 29841**

**401 S. Main St., Suite 200
Mount Airy, NC 27030**



**MOORE AND ASSOCIATES
ENGINEERING AND CONSULTING**

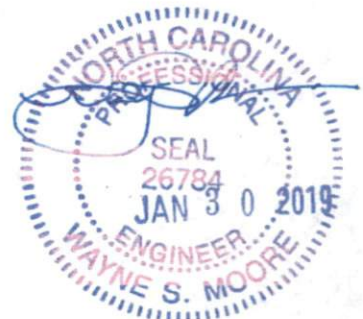

20' x 20'



**MOORE AND ASSOCIATES
ENGINEERING AND CONSULTING, INC.**

DRAWN BY: AT
CHECKED BY: PDH

STEEL BUILDINGS AND STRUCTURES, INC.
P.O. BOX 1287,
MOUNT AIRY, NC 27030
30'-0" x 20'-0" ENCLOSED STRUCTURE

THIS DOCUMENT IS THE PROPERTY OF MOORE AND ASSOCIATES ENGINEERING AND CONSULTING. THE UNAUTHORIZED REPRODUCTION, COPYING, OR OTHERWISE USE OF THIS DOCUMENT IS STRICTLY PROHIBITED AND ANY INFRINGEMENT THEREUPON MAY BE SUBJECT TO LEGAL ACTION.

PROJECT MGR: VSM
CLIENT: SBST

DATE: 12-14-18
SHT. 1
SCALE: NTS
DWG. NO.: SK-3
JOB NO.: 180685/182905
REV.: 7



**MOORE AND ASSOCIATES
ENGINEERING AND CONSULTING, INC.**

DRAWN BY: AT

CHECKED BY: PDH

PROJECT MGR: WSM

CLIENT: SBSI

STEEL BUILDINGS AND STRUCTURES, INC.
P.O. BOX 1287,
MOUNT AIRY, NC 27030
30'-0"x20'-0" ENCLOSED STRUCTURE

DATE: 12-14-18

SCALE: NTS

JTB NO: 180685/
181965/182905

SHT. 1A

DWG NO: SK-3

REV: 7

THIS DOCUMENT IS THE PROPERTY OF MOORE AND ASSOCIATES ENGINEERING AND CONSULTING. THE UNAUTHORIZED REPRODUCTION, COPYING, OR OTHERWISE USE OF THIS DOCUMENT IS STRICTLY PROHIBITED AND ANY INFRINGEMENT THEREUPON MAY BE SUBJECT TO LEGAL ACTION.

DRAWING INDEX

SHEET 1	PE SEAL COVER SHEET (1 OF 2)
SHEET 1A	PE SEAL COVER SHEET (2 OF 2)
SHEET 2	DRAWING INDEX
SHEET 3	INSTALLATION NOTES AND SPECIFICATIONS
SHEET 3A	TYPICAL SIDE AND END ELEVATIONS
SHEET 3B	TYPICAL SIDE AND END ELEVATIONS
SHEET 4	TYPICAL RAFTER/COLUMN FRAME AND SIDE FRAMING SECTION (BOX EAVE STRUCTURE)
SHEET 4A	TYPICAL RAFTER/COLUMN FRAME AND SIDE FRAMING SECTION (BOX EAVE STRUCTURE)
SHEET 4B	TYPICAL RAFTER/COLUMN FRAME AND SIDE FRAMING SECTION (BOX EAVE STRUCTURE)
SHEET 4C	TYPICAL RAFTER/COLUMN FRAME AND SIDE FRAMING SECTION (BOX EAVE STRUCTURE)
SHEET 4D	TYPICAL RAFTER/COLUMN FRAME AND SIDE FRAMING SECTION (BOX EAVE STRUCTURE)
SHEET 4E	TYPICAL RAFTER/COLUMN FRAME AND SIDE FRAMING SECTION (BOX EAVE STRUCTURE)
SHEET 5	COLUMN CONNECTION DETAILS (BOX EAVE STRUCTURE)
SHEET 5A	COLUMN CONNECTION DETAILS (BOX EAVE STRUCTURE)
SHEET 6	COLUMN CONNECTION DETAILS (BOX EAVE STRUCTURE)
SHEET 6A	COLUMN CONNECTION DETAILS (BOX EAVE STRUCTURE)
SHEET 7	BASE RAIL ANCHORAGE OPTIONS
SHEET 8	TYPICAL END WALL AND SIDE WALL FRAMING SECTIONS
SHEET 8A	TYPICAL END WALL AND SIDE WALL FRAMING SECTIONS
SHEET 9	CONNECTION DETAILS
SHEET 10	CONNECTION DETAILS
SHEET 11	LEAN-TO OPTIONS
SHEET 11A	LEAN-TO OPTIONS
SHEET 12	VERTICAL ROOF/SIDING OPTION END AND SIDE ELEVATION AND SECTION
SHEET 13	OPTIONAL HEADER
SHEET 14	ADDITIONAL BASE RAIL ANCHORAGE OPTION
SHEET 15	OPTIONAL BASE RAIL ON GRADE APPLICATION
SHEET 16	OPTIONAL BASE RAIL ON TIMBER BEAM
SHEET 17	OPTIONAL BASE RAIL ON TIMBER BEAM WITH SOIL NAIL
SHEET 18	OPTIONAL CONCRETE STRIP FOOTING



MOORE AND ASSOCIATES ENGINEERING AND CONSULTING, INC.	DRAWN BY: AT	STEEL BUILDINGS AND STRUCTURES, INC. P.O. BOX 1287, MOUNT AIRY, NC 27030 30'-0" x 20'-0" ENCLOSED STRUCTURE		
	CHECKED BY: PDH			
THIS DOCUMENT IS THE PROPERTY OF MOORE AND ASSOCIATES ENGINEERING AND CONSULTING. THE UNAUTHORIZED REPRODUCTION, COPYING, OR OTHERWISE USE OF THIS DOCUMENT IS STRICTLY PROHIBITED AND ANY INFRINGEMENT THEREUPON MAY BE SUBJECT TO LEGAL ACTION.	PROJECT MGR: WSH	DATE: 12-14-18	SCALE: NTS	JOB NO: 18068S/ 18156S/18290S
	CLIENT: SBSI	SHT. 2	DWG. NO: SK-3	REV: 7

INSTALLATION NOTES AND SPECIFICATIONS

1. DESIGN IS FOR MAXIMUM 30'-0" WIDE x 20'-0" EAVE HEIGHT ENCLOSED STRUCTURES.
2. DESIGN WAS DONE IN ACCORDANCE WITH THE 2017 FLORIDA BUILDING CODE (FBC) 6TH EDITION, 2018 NORTH CAROLINA BUILDING CODE, 2006 INTERNATIONAL BUILDING CODE (IBC), 2009 IBC, 2012 IBC AND 2015 IBC.
3. DESIGN LOADS ARE AS FOLLOWS:
 - A) DEAD LOAD = 1.5 PSF
 - B) LIVE LOAD = 12 PSF
 - C) GROUND SNOW LOAD = 30 PSF ($W \leq 26'-0"$), 35 PSF ($26'-0" < W \leq 30'-0"$)
(UNBALANCED SNOW LOADS DUE TO DRIFTING HAVE NOT BEEN EVALUATED.)
4. 3-SECOND GUST ULTIMATE WIND SPEED (V_{ULT}) 105 TO 145 MPH (NOMINAL WIND SPEED 82 TO 112 MPH) MAXIMUM RAFTER/COLUMN AND END COLUMN SPACING = 5.0 FEET (UNLESS NOTED OTHERWISE).
5. END WALL COLUMNS (POST) ARE EQUIVALENT TO SIDE WALL POSTS UNLESS NOTED OTHERWISE.
6. RISK CATEGORY I.
7. WIND EXPOSURE CATEGORY B.
8. SPECIFICATIONS APPLICABLE TO 29 GAUGE METAL PANELS FASTENED DIRECTLY TO 2 1/2" x 2 1/2" - 14 GAUGE TUBE STEEL (TS) FRAMING MEMBERS (UNLESS NOTED OTHERWISE).
9. AVERAGE FASTENER SPACING ON-CENTERS ALONG RAFTERS OR HAT CHANNELS, AND COLUMNS (INTERIOR OR END) = 8 INCHES.
10. FASTENERS CONSIST OF 1/4"x3/4" SELF-DRILLING FASTENER (SDF), USE CONTROL SEAL WASHER WITH EXTERIOR FASTENERS. SPECIFICATIONS APPLICABLE ONLY FOR MEAN ROOF HEIGHT OF 20 FEET OR LESS, AND ROOF SLOPES OF 14° (3:12 PITCH) OR LESS. SPACING REQUIREMENTS FOR OTHER ROOF HEIGHTS AND/OR SLOPES MAY VARY.
11. GROUND ANCHORS SHALL BE INSTALLED THROUGH BASE RAIL WITHIN 6" OF EACH COLUMN.
12. GROUND ANCHORS CONSIST OF #4 REBAR W/ WELDED NUT x 36" LONG IN SUITABLE SOIL CONDITIONS. OPTIONAL ANCHORAGE MAY BE USED IN SUITABLE SOILS AND MUST BE USED IN UNSUITABLE SOILS AS NOTED.
13. WIND FORCES GOVERN OVER SEISMIC FORCES. SEISMIC PARAMETERS ANALYZED ARE:
 SOIL SITE CLASS = D
 RISK CATEGORY I/II/III
 $R = 3.25$ $I_e = 1.0$
 $S_{ys} = 2.039$ $V = C_s W$
 $S_{m1} = 1.258$
14. WINDOW AND DOOR DESIGN PRESSURES ARE APPLICABLE TO THE STATE OF FLORIDA ONLY.



**MOORE AND ASSOCIATES
ENGINEERING AND CONSULTING, INC.**

DRAWN BY: AT

CHECKED BY: PJM

PROJECT MGR: WSM

CLIENT: SBSI

STEEL BUILDINGS AND STRUCTURES, INC.
P.O. BOX 1287,
MOUNT AIRY, NC 27030
30'-0"x20'-0" ENCLOSED STRUCTURE

DATE: 12-14-18

SHT. 3

SCALE: NTS

DWG. NO. SK-3

JOB NO. 18068S/
18156S/18290S

REV. 7

THIS DOCUMENT IS THE PROPERTY OF MOORE AND ASSOCIATES ENGINEERING AND CONSULTING. THE UNAUTHORIZED REPRODUCTION, COPYING, OR OTHERWISE USE OF THIS DOCUMENT IS STRICTLY PROHIBITED AND ANY INFRINGEMENT THEREUPON MAY BE SUBJECT TO LEGAL ACTION.

BOX EAVE FRAME RAFTER STRUCTURE

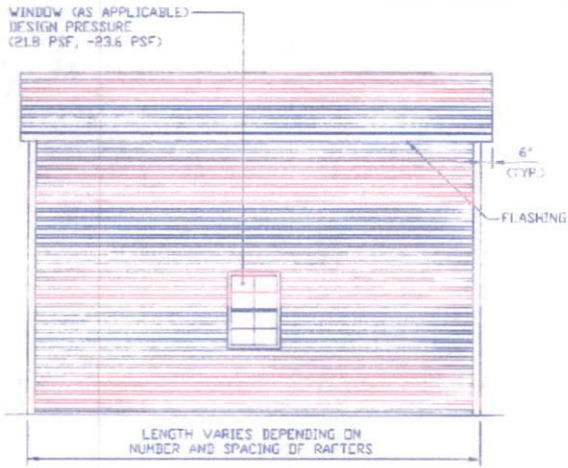

TYPICAL SIDE ELEVATION
SCALE: NTS

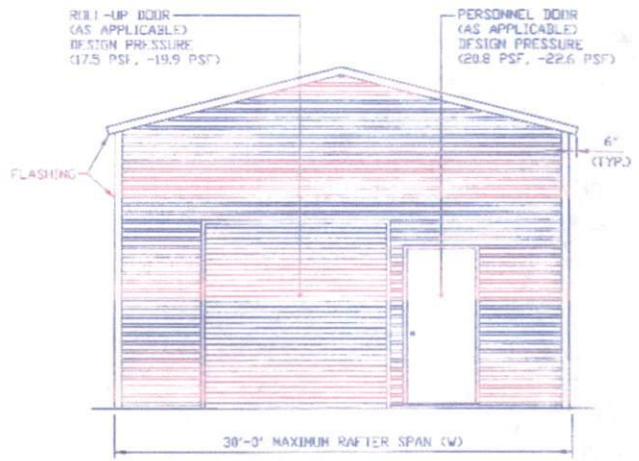

TYPICAL END ELEVATION
SCALE: NTS



**MOORE AND ASSOCIATES
ENGINEERING AND CONSULTING, INC.**

DRAWN BY: AT

CHECKED BY: PDH

PROJECT MGR: VSM

CLIENT: SBSI

STEEL BUILDINGS AND STRUCTURES, INC.
P.O. BOX 1287,
MOUNT AIRY, NC 27030
30'-0" x 20'-0" ENCLOSED STRUCTURE

DATE: 12-14-18

SCALE: NTS

DWG. NO: SK-3

JOB NO: 181565/182905

SHT. 3A

REV: 7

THIS DOCUMENT IS THE PROPERTY OF MOORE AND ASSOCIATES ENGINEERING AND CONSULTING. THE UNAUTHORIZED REPRODUCTION, COPYING, OR OTHERWISE USE OF THIS DOCUMENT IS STRICTLY PROHIBITED AND ANY INFRINGEMENT THEREUPON MAY BE SUBJECT TO LEGAL ACTION.

BOW EAVE FRAME RAFTER STRUCTURE

WINDOW (AS APPLICABLE)
DESIGN PRESSURE
(21.8 PSF, -23.6 PSF)

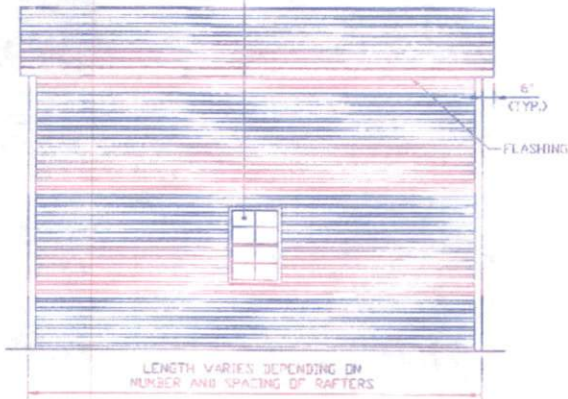

TYPICAL SIDE ELEVATION
SCALE: NTS

ROLL-UP DOOR
(AS APPLICABLE)
DESIGN PRESSURE
(17.5 PSF, -19.9 PSF)

PERSONNEL DOOR
(AS APPLICABLE)
DESIGN PRESSURE
(20.8 PSF, -22.6 PSF)

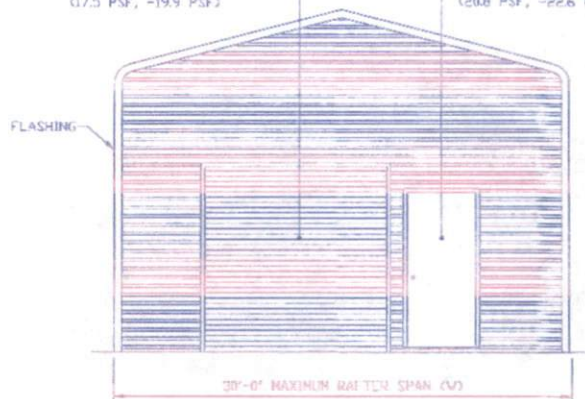

TYPICAL END ELEVATION
SCALE: NTS



**MOORE AND ASSOCIATES
ENGINEERING AND CONSULTING, INC.**

DRAWN BY: AT

CHECKED BY: PDH

PROJECT MGR: WSM

CLIENT: SRSE

STEEL BUILDINGS AND STRUCTURES, INC.
P.O. BOX 1287,
MOUNT AIRY, NC 27030
30'-0" x 20'-0" ENCLOSED STRUCTURE

DATE: 12-14-18

SHT. 3B

SCALE: NTS

DWG. NO: SK-3

JOB NO: 1806RS/
18156S/18290S

REV: 7

THIS DOCUMENT IS THE PROPERTY OF MOORE AND ASSOCIATES ENGINEERING AND CONSULTING. THE UNAUTHORIZED REPRODUCTION, COPYING, OR OTHERWISE USE OF THIS DOCUMENT IS STRICTLY PROHIBITED AND ANY INFRINGEMENT THEREUPON MAY BE SUBJECT TO LEGAL ACTION.

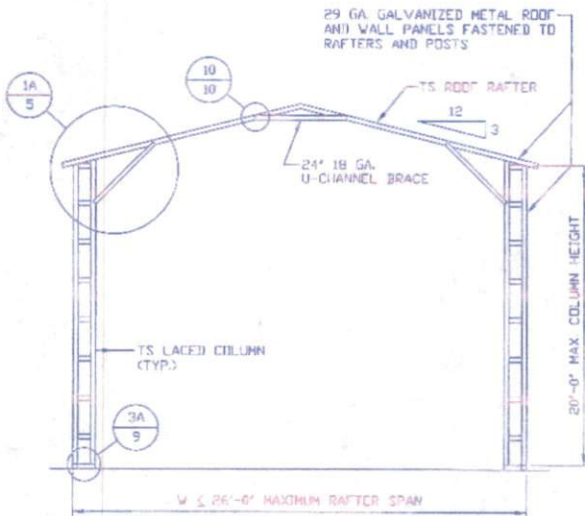

TYPICAL RAFTER/COLUMN FRAME SECTION
SCALE: NTS

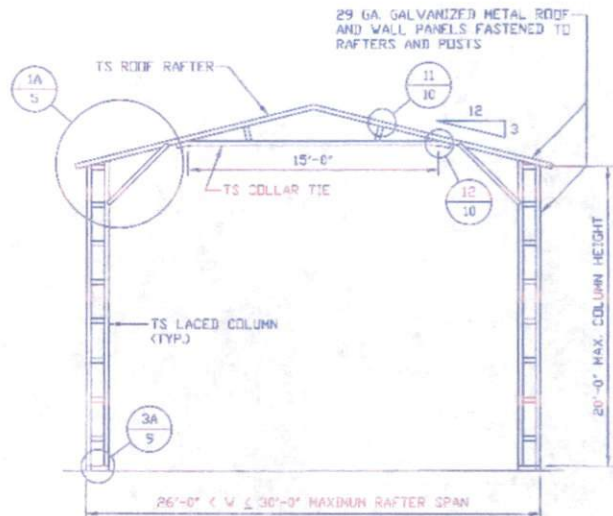

TYPICAL RAFTER/COLUMN FRAME SECTION
SCALE: NTS

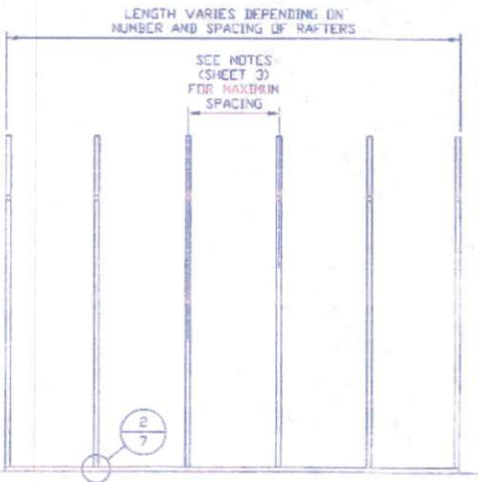

TYPICAL RAFTER/COLUMN SIDE FRAMING SECTION
SCALE: NTS



**MOORE AND ASSOCIATES
ENGINEERING AND CONSULTING, INC.**

DRAWN BY: AT

CHECKED BY: PDH

PROJECT MGR: WSH

CLIENT: SBSI

STEEL BUILDINGS AND STRUCTURES, INC.
P.O. BOX 1287,
MOUNT AIRY, NC 27030
30'-0" x 20'-0" ENCLOSED STRUCTURE

DATE: 12-14-18

SHT. 4

SCALE: NTS

DWG. NO: SK-3

180685/
JTS NO: 181565/182905

REV: 7

THIS DOCUMENT IS THE PROPERTY OF MOORE AND ASSOCIATES ENGINEERING AND CONSULTING. THE UNAUTHORIZED REPRODUCTION, COPYING, OR OTHERWISE USE OF THIS DOCUMENT IS STRICTLY PROHIBITED AND ANY INFRINGEMENT THEREUPON MAY BE SUBJECT TO LEGAL ACTION.

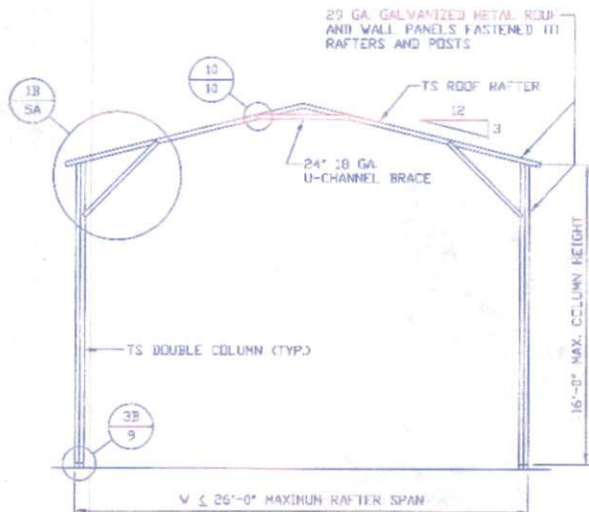

TYPICAL RAFTER/COLUMN FRAME SECTION
SCALE: NTS

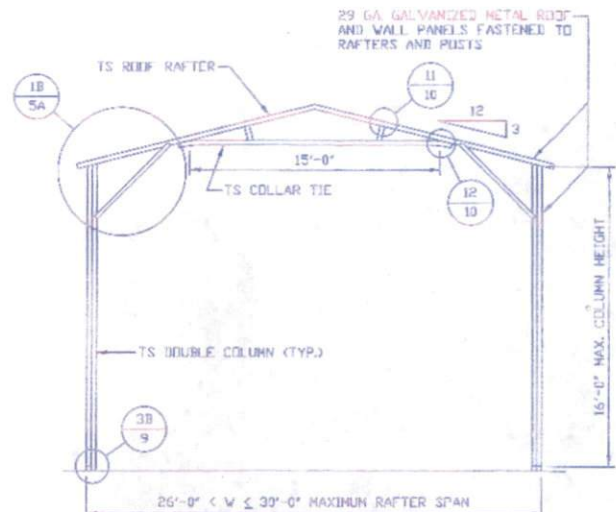

TYPICAL RAFTER/COLUMN FRAME SECTION
SCALE: NTS

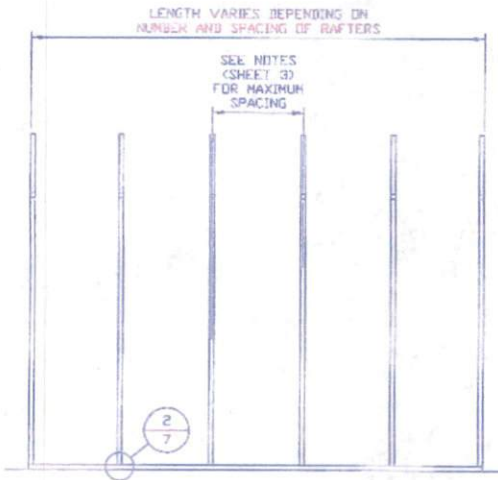

TYPICAL RAFTER/COLUMN SIDE FRAMING SECTION
SCALE: NTS



**MOORE AND ASSOCIATES
ENGINEERING AND CONSULTING, INC.**

DRAWN BY: AT

CHECKED BY: PDH

PROJECT MGR: VSM

CLIENT: SBST

STEEL BUILDINGS AND STRUCTURES, INC.
P.O. BOX 1287,
MOUNT AIRY, NC 27030
30'-0" x 20'-0" ENCLOSED STRUCTURE

DATE: 12-14-18

SHT. 4A

SCALE: NTS

DWG. NO: SK-3

JOB NO: 180683/
18156S/18290S

REV: 7

THIS DOCUMENT IS THE PROPERTY OF MOORE AND ASSOCIATES ENGINEERING AND CONSULTING. THE UNAUTHORIZED REPRODUCTION, COPYING, OR OTHERWISE USE OF THIS DOCUMENT IS STRICTLY PROHIBITED AND ANY INFRINGEMENT THEREUPON MAY BE SUBJECT TO LEGAL ACTION.

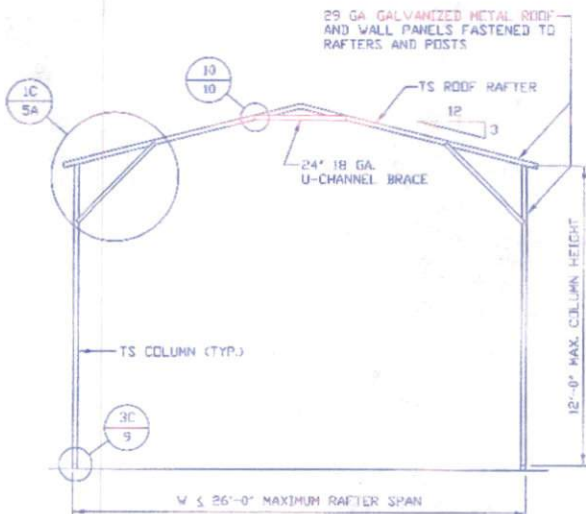

TYPICAL RAFTER/COLUMN FRAME SECTION
SCALE: NTS

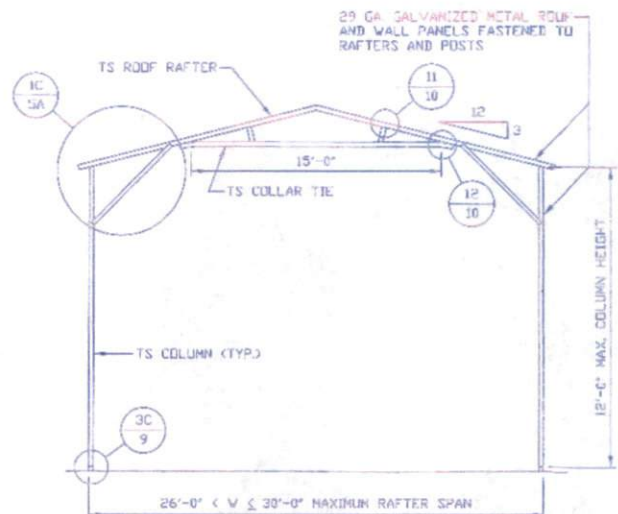

TYPICAL RAFTER/COLUMN FRAME SECTION
SCALE: NTS

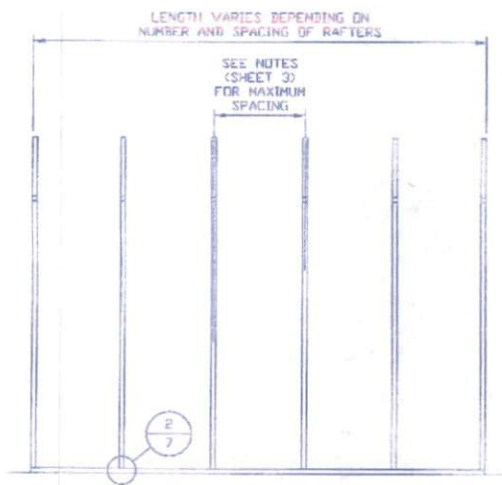

TYPICAL RAFTER/COLUMN SIDE FRAMING SECTION
SCALE: NTS

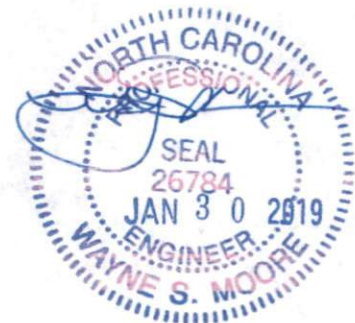

**MOORE AND ASSOCIATES
ENGINEERING AND CONSULTING, INC.**

DRAWN BY: AT

CHECKED BY: PDH

PROJECT MGR: WSM

CLIENT: SSSI

STEEL BUILDINGS AND STRUCTURES, INC.
P.O. BOX 1287,
MOUNT AIRY, NC 27030
30'-0" x 20'-0" ENCLOSED STRUCTURE

DATE: 12-14-18

SHT. 4B

SCALE: NTS

DWG. NO: SK-3

JOB NO: 18068S/
18156S/18290S

REV: 7

THIS DOCUMENT IS THE PROPERTY OF MOORE AND ASSOCIATES ENGINEERING AND CONSULTING. THE UNAUTHORIZED REPRODUCTION, COPYING, OR OTHERWISE USE OF THIS DOCUMENT IS STRICTLY PROHIBITED AND ANY INFRINGEMENT THEREUPON MAY BE SUBJECT TO LEGAL ACTION.

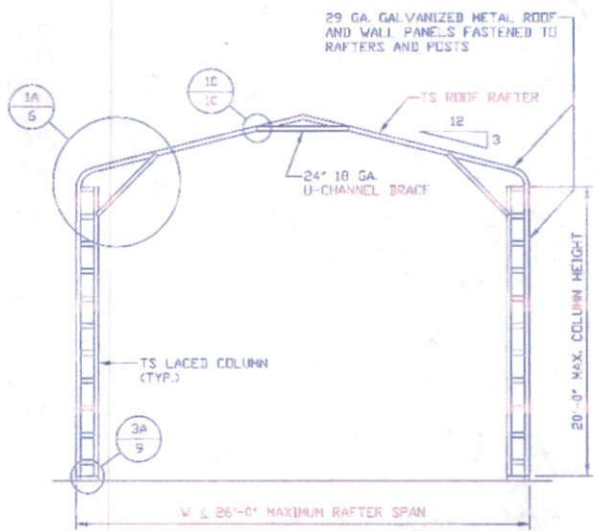

TYPICAL RAFTER/COLUMN FRAME SECTION
SCALE: NTS

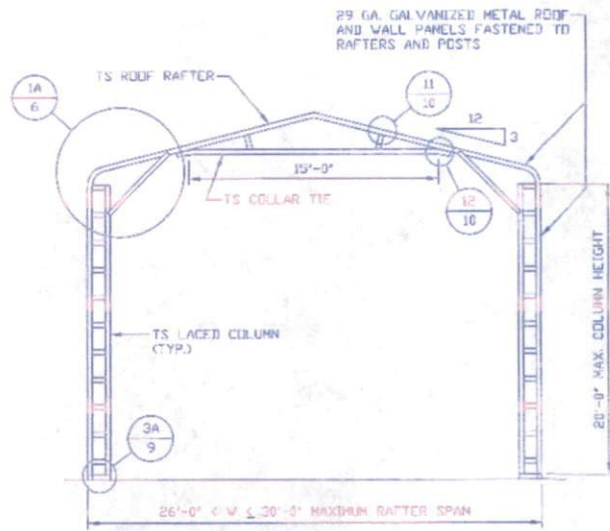

TYPICAL RAFTER/COLUMN FRAME SECTION
SCALE: NTS

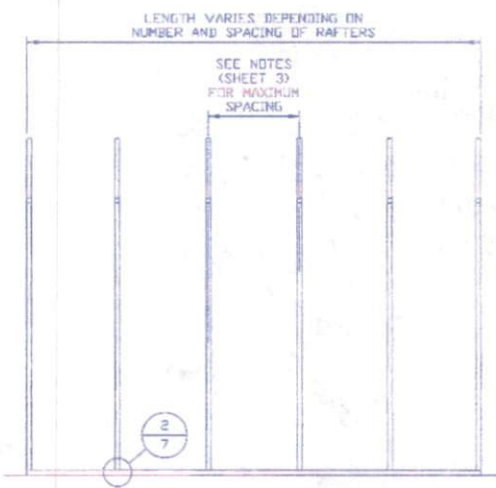

TYPICAL RAFTER/COLUMN SIDE FRAMING SECTION
SCALE: NTS



MOORE AND ASSOCIATES ENGINEERING AND CONSULTING, INC.	DRAWN BY: AT	STEEL BUILDINGS AND STRUCTURES, INC. P.O. BOX 1287, MOUNT AIRY, NC 27030 30'-0" x 20'-0" ENCLOSED STRUCTURE		
	CHECKED BY: PDH			
<small>THIS DOCUMENT IS THE PROPERTY OF MOORE AND ASSOCIATES ENGINEERING AND CONSULTING. THE UNAUTHORIZED REPRODUCTION, COPYING, OR OTHERWISE USE OF THIS DOCUMENT IS STRICTLY PROHIBITED AND ANY INFRINGEMENT THEREUPON MAY BE SUBJECT TO LEGAL ACTION.</small>	PROJECT MGR: WSM	DATE: 12-14-18	SCALE: NTS	JOB NO: 181565/182905 180685/
	CLIENT: SBSI	SHT. 4C	DWG. NO: SK-3	REV: 7

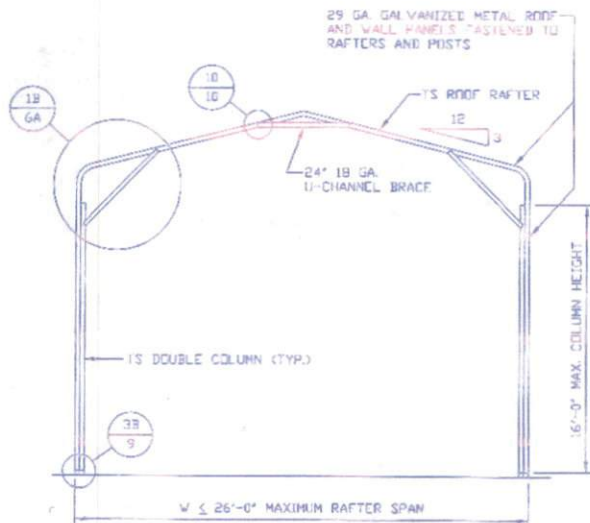

TYPICAL RAFTER/COLUMN FRAME SECTION
SCALE: NTS

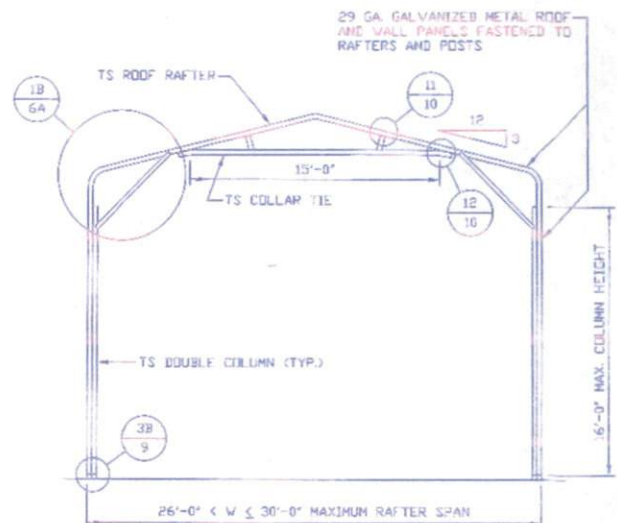

TYPICAL RAFTER/COLUMN FRAME SECTION
SCALE: NTS

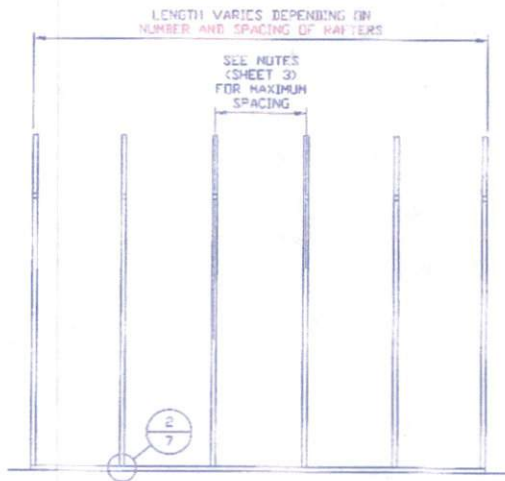

TYPICAL RAFTER/COLUMN SIDE FRAMING SECTION
SCALE: NTS



**MOORE AND ASSOCIATES
ENGINEERING AND CONSULTING, INC.**

DRAWN BY: AT

CHECKED BY: PDH

PROJECT MGR: VSM

CLIENT: SBSI

STEEL BUILDINGS AND STRUCTURES, INC.
P.O. BOX 1287,
MOUNT AIRY, NC 27030
30'-0" x 20'-0" ENCLOSED STRUCTURE

DATE: 12-14-18

SHT. 4D

SCALE: NTS

DWG. NO: SK-3

**JOB NO: 180685/
181563/182905**

REV: 7

THIS DOCUMENT IS THE PROPERTY OF MOORE AND ASSOCIATES ENGINEERING AND CONSULTING. THE UNAUTHORIZED REPRODUCTION, COPYING, OR OTHERWISE USE OF THIS DOCUMENT IS STRICTLY PROHIBITED AND ANY INFREEMENT THEREUPON MAY BE SUBJECT TO LEGAL ACTION.

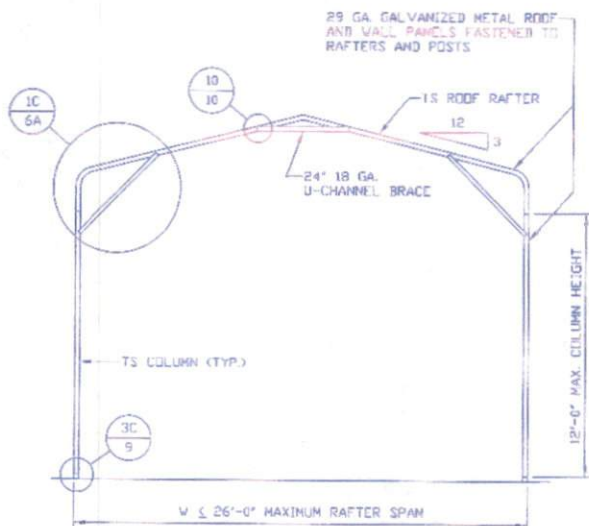

TYPICAL RAFTER/COLUMN FRAME SECTION
SCALE: NTS

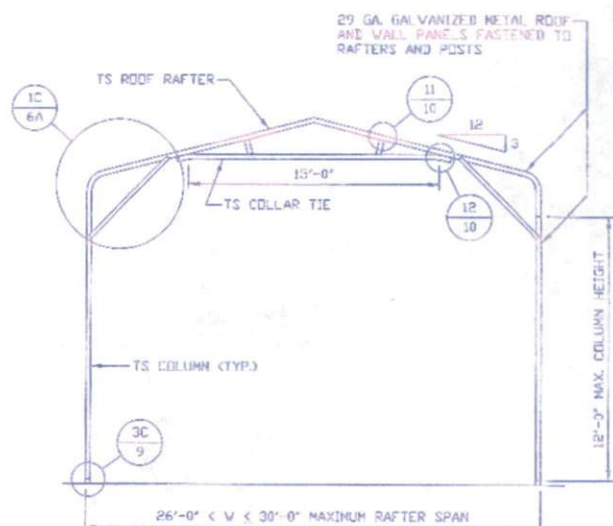

TYPICAL RAFTER/COLUMN FRAME SECTION
SCALE: NTS

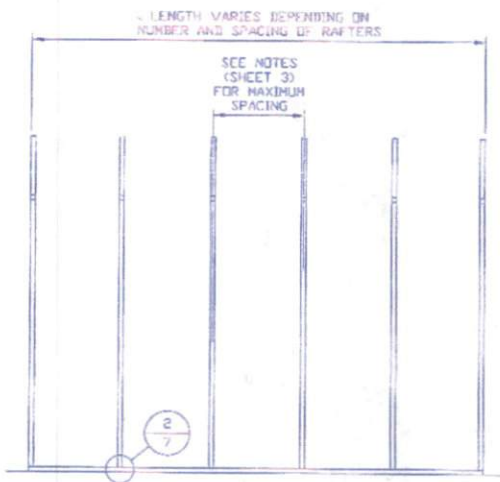

TYPICAL RAFTER/COLUMN SIDE FRAMING SECTION
SCALE: NTS



**MOORE AND ASSOCIATES
ENGINEERING AND CONSULTING, INC.**

DRAWN BY: AT

CHECKED BY: PDH

PROJECT MGR: VSM

CLIENT: SBST

STEEL BUILDINGS AND STRUCTURES, INC.
P.O. BOX 1287,
MOUNT AIRY, NC 27030
30'-0" x 20'-0" ENCLOSED STRUCTURE

DATE: 12-14-18

SHT. 4E

SCALE: NTS

DWG. NO: SK-3

JOB NO: 180685/
181565/182905

REV: 7

THIS DOCUMENT IS THE PROPERTY OF MOORE AND ASSOCIATES ENGINEERING AND CONSULTING. THE UNAUTHORIZED REPRODUCTION, COPYING, OR OTHERWISE USE OF THIS DOCUMENT IS STRICTLY PROHIBITED AND ANY INFRINGEMENT THEREUPON MAY BE SUBJECT TO LEGAL ACTION.

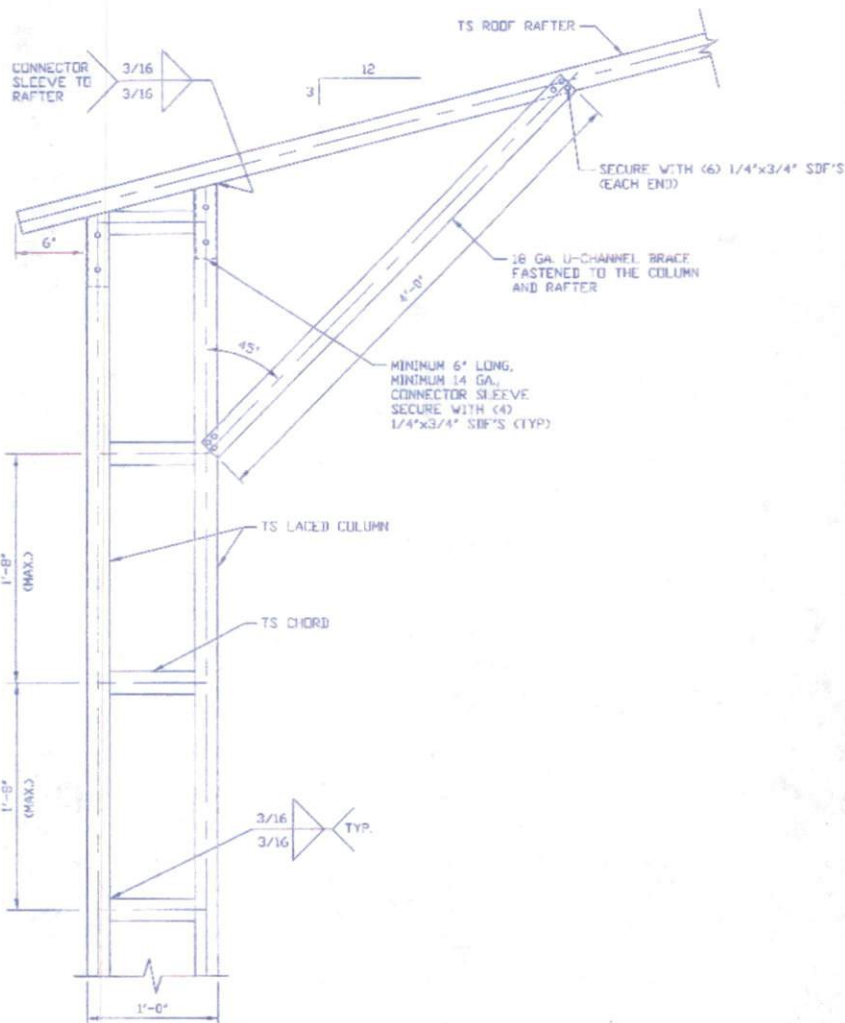

1A

BOX EAVE RAFTER/CORNER POST CONNECTION DETAIL
FOR HEIGHTS 16'-0" < TO ≤ 20'-0"
 SCALE: NTS

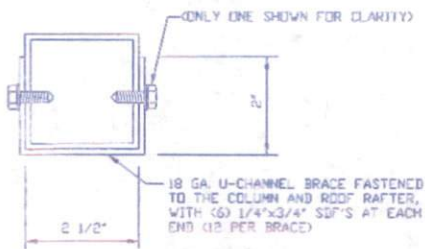

BRACE SECTION
 SCALE: NTS



MOORE AND ASSOCIATES
ENGINEERING AND CONSULTING, INC.

DRAWN BY: AT

CHECKED BY: PJM

PROJECT MGR: WSM

CLIENT: SBSI

STEEL BUILDINGS AND STRUCTURES, INC.
 P.O. BOX 1287,
 MOUNT AIRY, NC 27030
 30'-0" x 20'-0" ENCLOSED STRUCTURE

DATE: 12-14-18

SCALE: NTS

DWG. NO: SK-3

JOB NO: 180685/182905

SHT. 5

REV. 7

THIS DOCUMENT IS THE PROPERTY OF MOORE AND ASSOCIATES ENGINEERING AND CONSULTING. THE UNAUTHORIZED REPRODUCTION, COPYING, OR OTHERWISE USE OF THIS DOCUMENT IS STRICTLY PROHIBITED AND ANY INFRINGEMENT THEREUPON MAY BE SUBJECT TO LEGAL ACTION.

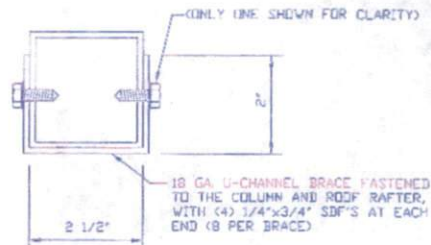
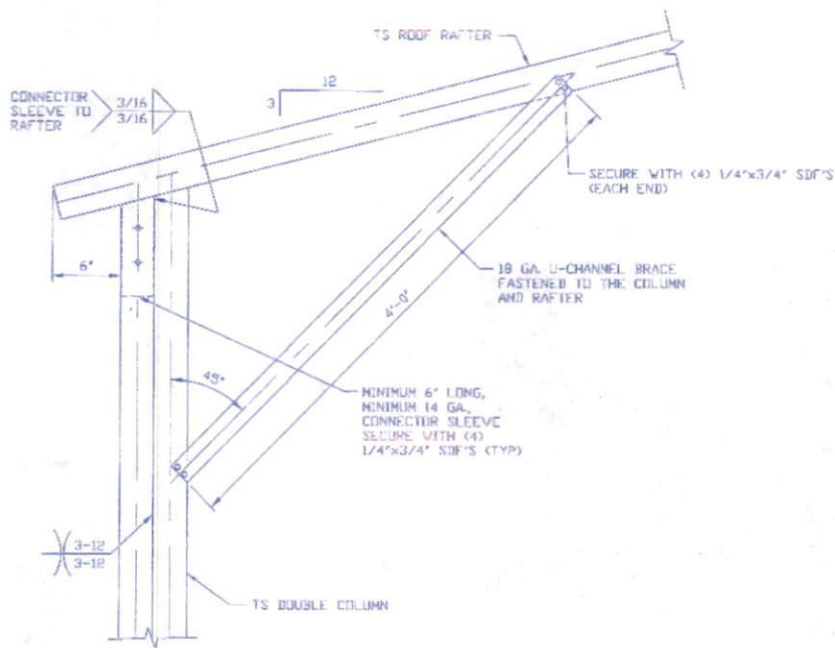

BRACE SECTION
SCALE: NTS

1B

BOX EAVE RAFTER/CORNER POST CONNECTION DETAIL
FOR HEIGHTS 12'-0" < TO ≤ 16'-0"
SCALE: NTS

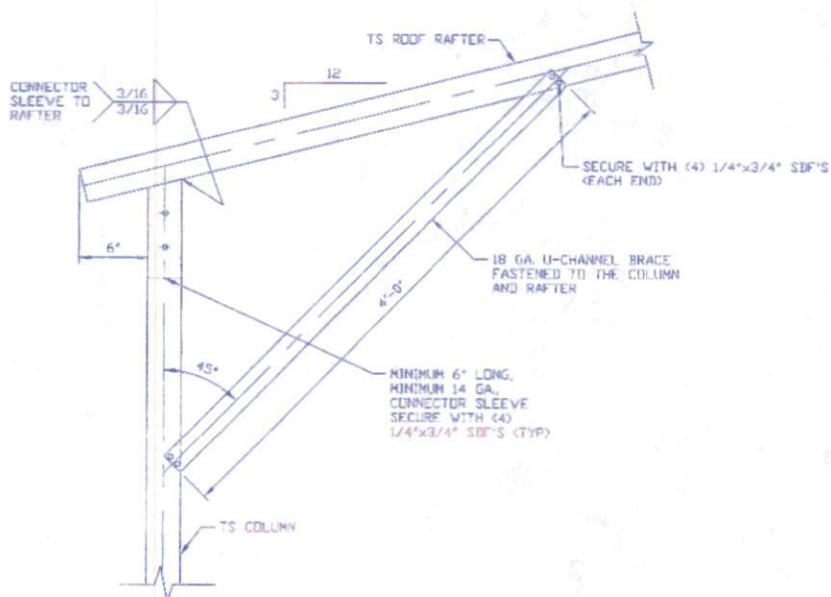

1C

BOX EAVE RAFTER/CORNER POST CONNECTION DETAIL
FOR HEIGHTS ≤ 12'-0"
SCALE: NTS



MOORE AND ASSOCIATES
ENGINEERING AND CONSULTING, INC.

DRAWN BY: AT

CHECKED BY: PDH

PROJECT MGR: WSM

CLIENT: SRSI

STEEL BUILDINGS AND STRUCTURES, INC.
P.O. BOX 1287,
MOUNT AIRY, NC 27030
30'-0" x 20'-0" ENCLOSED STRUCTURE

DATE: 12-14-18

SHT. 5A

SCALE: NTS

DWG. NO: SK-3

JOB NO: 18156S/18290S

REV: 7

THIS DOCUMENT IS THE PROPERTY OF MOORE AND ASSOCIATES ENGINEERING AND CONSULTING. THE UNAUTHORIZED REPRODUCTION, COPYING, OR OTHERWISE USE OF THIS DOCUMENT IS STRICTLY PROHIBITED AND ANY INFRINGEMENT THEREUPON MAY BE SUBJECT TO LEGAL ACTION.

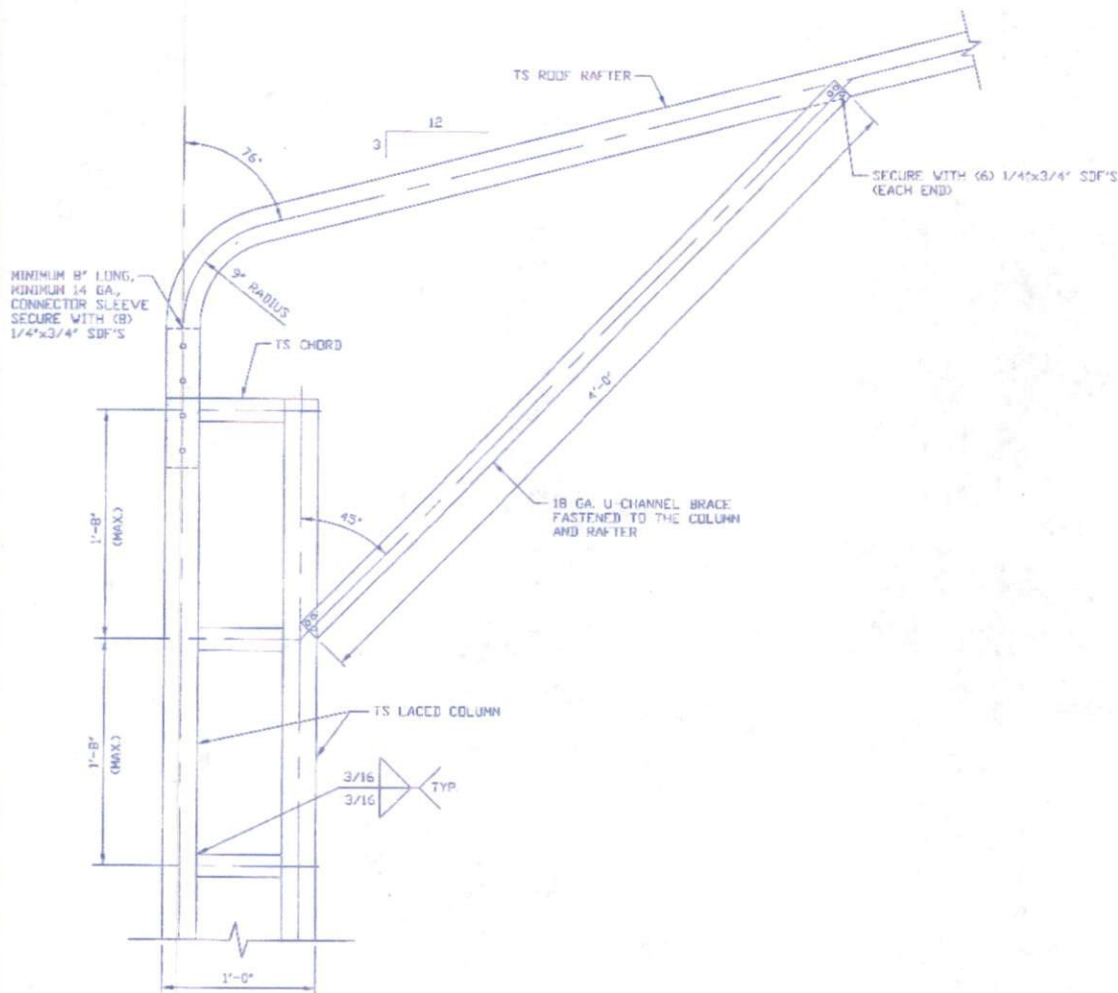

1A BOX EAVE RAFTER/CORNER POST CONNECTION DETAIL FOR HEIGHTS 16'-0" < TO ≤ 20'-0" SCALE: NTS

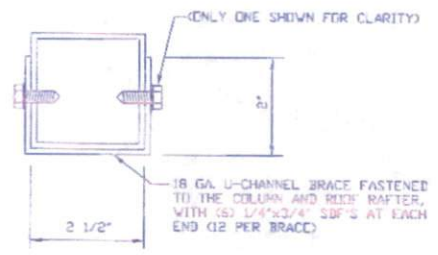

BRACE SECTION SCALE: NTS



MOORE AND ASSOCIATES ENGINEERING AND CONSULTING, INC.

DRAWN BY: AT		STEEL BUILDINGS AND STRUCTURES, INC.		
CHECKED BY: PDH		P.O. BOX 1287, MOUNT AIRY, NC 27030		
PROJECT MGR: VSM	DATE: 12-14-19	SCALE: NTS	JOB NO: 18068S/18290S	
CLIENT: SBSI	SHT. 6	DWG. NO: SK-3	REV: 7	

THIS DOCUMENT IS THE PROPERTY OF MOORE AND ASSOCIATES ENGINEERING AND CONSULTING. THE UNAUTHORIZED REPRODUCTION, COPYING, OR OTHERWISE USE OF THIS DOCUMENT IS STRICTLY PROHIBITED AND ANY INFRINGEMENT THEREUPON MAY BE SUBJECT TO LEGAL ACTION.

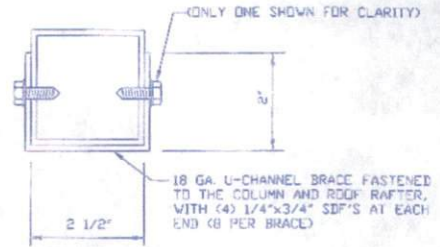
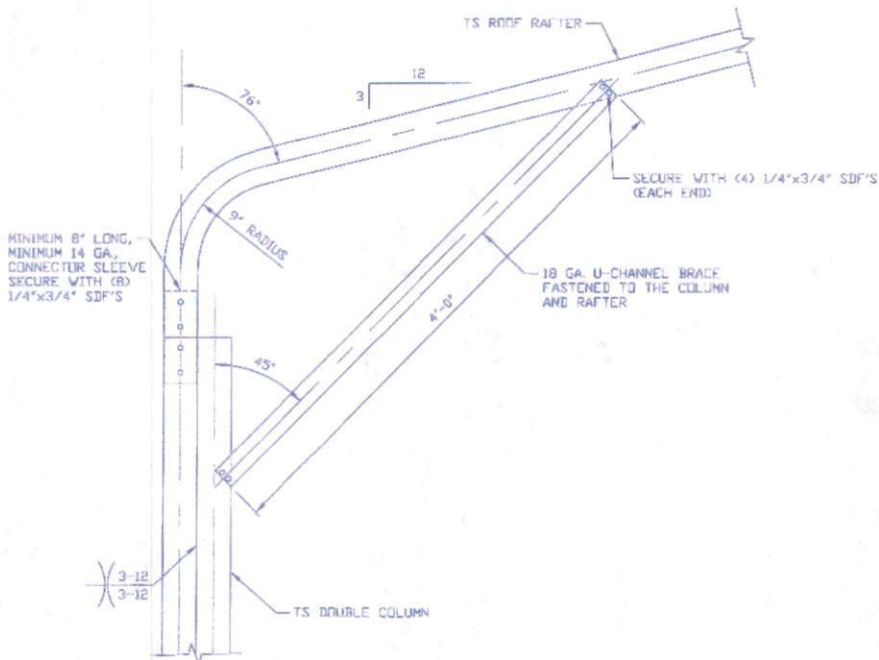

BRACE SECTION
SCALE: NTS

1B

BOX EAVE RAFTER/CORNER POST CONNECTION DETAIL
FOR HEIGHTS 12'-0" < TO ≤ 16'-0"
SCALE: NTS

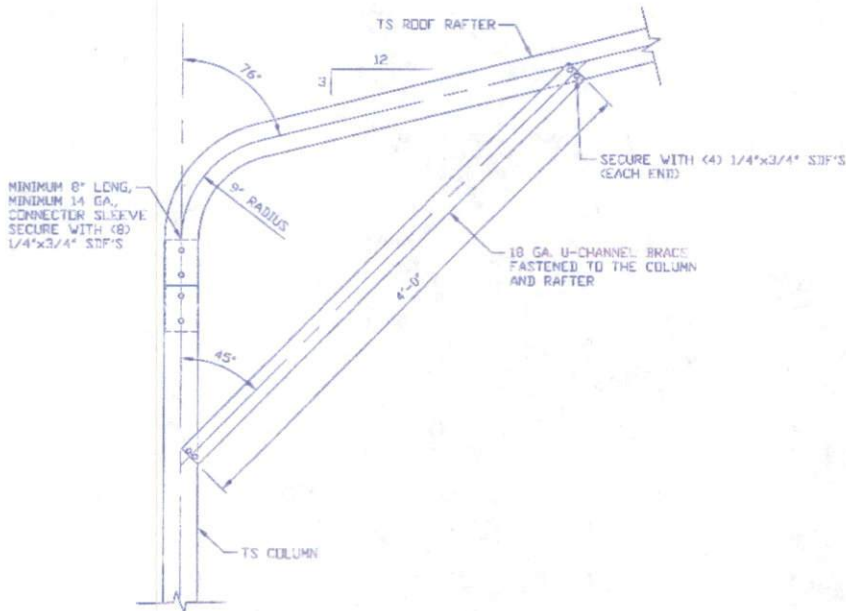

1C

BOX EAVE RAFTER/CORNER POST CONNECTION DETAIL
FOR HEIGHTS ≤ 12'-0"
SCALE: NTS

MOORE AND ASSOCIATES
ENGINEERING AND CONSULTING, INC.

DRAWN BY: AT
CHECKED BY: PDH
PROJECT MGR: VSM
CLIENT: SSSI

STEEL BUILDINGS AND STRUCTURES, INC.
P.O. BOX 1287,
MOUNT AIRY, NC 27030
30'-0" x 20'-0" ENCLOSED STRUCTURE

DATE: 12-14-18
SCALE: NTS
JOB NO: 18068S/
18156S/18290S
SHT. 6A
DWG. NO: SK-3
REV: 7

THIS DOCUMENT IS THE PROPERTY OF MOORE AND ASSOCIATES ENGINEERING AND CONSULTING. THE UNAUTHORIZED REPRODUCTION, COPYING, OR OTHERWISE USE OF THIS DOCUMENT IS STRICTLY PROHIBITED AND ANY INFRINGEMENT THEREUPON MAY BE SUBJECT TO LEGAL ACTION.

BASE RAIL ANCHORAGE OPTIONS

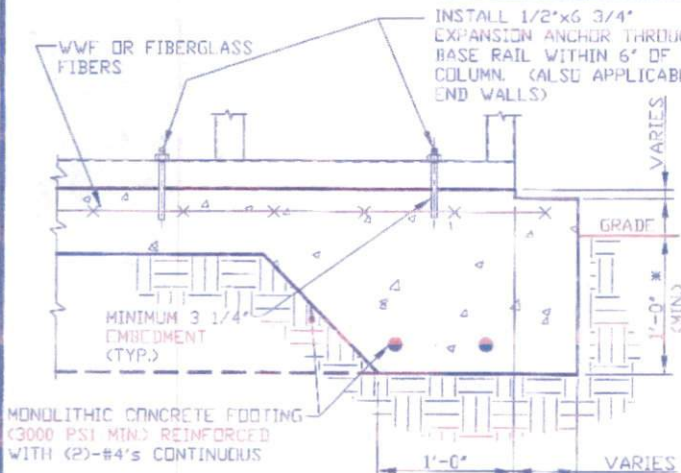

2A

CONCRETE MONOLITHIC SLAB BASE RAIL ANCHORAGE

SCALE: NTS
MINIMUM ANCHOR EDGE DISTANCE IS 4".
* COORDINATE WITH LOCAL CODES/ORD.

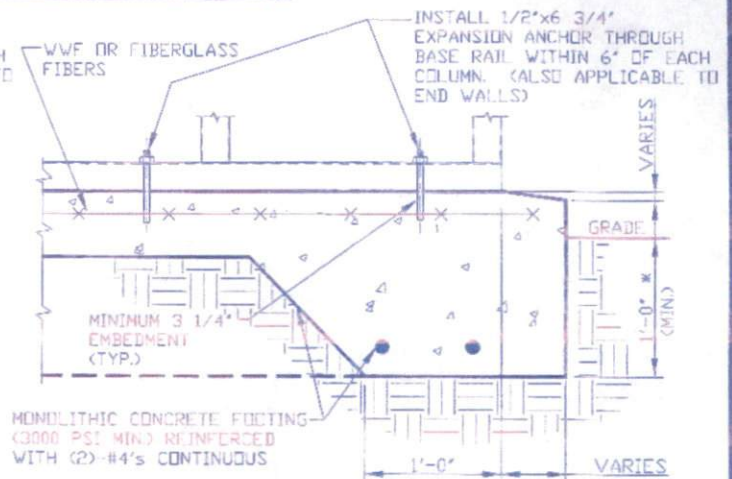

2B

CONCRETE SLAB BASE RAIL ANCHORAGE

SCALE: NTS
MINIMUM ANCHOR EDGE DISTANCE IS 4".
* COORDINATE WITH LOCAL CODES/ORD.

GENERAL NOTES

NOTE: CONCRETE MONOLITHIC SLAB DESIGN BASED ON MINIMUM SOIL BEARING CAPACITY OF 1,500 PSF.

CONCRETE:

CONCRETE SHALL HAVE A MINIMUM SPECIFIED COMPRESSIVE STRENGTH OF 3,000 PSI AT 28 DAYS.

COVER OVER REINFORCING STEEL:

FOR FOUNDATIONS, MINIMUM CONCRETE COVER OVER REINFORCING BARS SHALL BE PER ACI-318:
3" IN FOUNDATIONS WHERE THE CONCRETE IS CAST AGAINST AND PERMANENTLY IN CONTACT WITH THE EARTH OR EXPOSED TO THE EARTH OR WEATHER, AND 1 1/2" ELSEWHERE.

REINFORCING STEEL:

THE TURNDOWN REINFORCING STEEL SHALL BE ASTM A615 GRADE 60. THE SLAB REINFORCEMENT SHALL BE WELDED WIRE FABRIC MEETING ASTM A185 OR FIBERGLASS FIBER REINFORCEMENT.

REINFORCEMENT MAY BE BENT IN THE SHOP OR THE FIELD PROVIDED:

1. REINFORCEMENT IS BENT COLD.
2. THE DIAMETER OF THE BEND, MEASURED ON THE INSIDE OF THE BAR, IS NOT LESS THAN SIX-BAR DIAMETERS.
3. REINFORCEMENT PARTIALLY EMBEDDED IN CONCRETE SHALL NOT BE FIELD BENT.

HELIX ANCHOR NOTES:

1. FOR VERY DENSE AND/OR CEMENTED SANDS, COARSE GRAVEL AND COBBLES, CALCICHE, PRELOADED SILTS AND CLAYS, USE MINIMUM (2) 4" HELICES WITH MINIMUM 30" EMBEDMENT OR SINGLE 6" HELIX WITH MINIMUM 50" EMBEDMENT.
2. FOR CORAL USE MINIMUM (2) 4" HELICES WITH MINIMUM 30" EMBEDMENT OR SINGLE 6" HELIX WITH MINIMUM 50" EMBEDMENT.
3. FOR MEDIUM DENSE COARSE SANDS, SANDY GRAVELS, VERY STIFF SILTS, AND CLAYS USE MINIMUM (2) 4" HELICES WITH MINIMUM 30 INCH EMBEDMENT OR SINGLE 6" HELIX WITH MINIMUM 50" EMBEDMENT.
4. FOR LOOSE TO MEDIUM DENSE SANDS, FIRM TO STIFF CLAYS AND SILTS ALLUVIAL FILL, USE MINIMUM (2) 6" HELICES WITH MINIMUM 50" EMBEDMENT.
5. FOR VERY LOOSE TO MEDIUM DENSE SANDS, FIRM TO STIFFER CLAYS AND SILTS, ALLUVIAL FILL, USE MINIMUM (2) 8" HELICES WITH MINIMUM 60" EMBEDMENT.

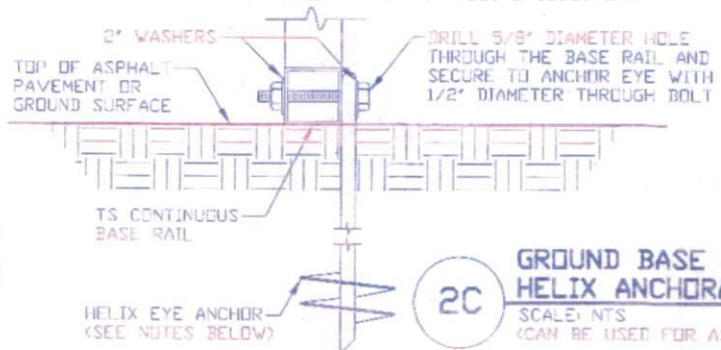

2C

GROUND BASE HELIX ANCHORAGE

SCALE: NTS
(CAN BE USED FOR ASPHALT)



**MOORE AND ASSOCIATES
ENGINEERING AND CONSULTING, INC.**

DRAWN BY: AT

CHECKED BY: PDH

PROJECT MGR: WSM

CLIENT: SBST

STEEL BUILDINGS AND STRUCTURES, INC.
P.O. BOX 1287,
MOUNT AIRY, NC 27030
30'-0" X 20'-0" ENCLOSED STRUCTURE

DATE: 12-14-18

SHT. 7

SCALE: NTS

DWG. NO: SK-3

JOB NO: 180685/182905

REV. 7

THIS DOCUMENT IS THE PROPERTY OF MOORE AND ASSOCIATES ENGINEERING AND CONSULTING. THE UNAUTHORIZED REPRODUCTION, COPYING, OR OTHERWISE USE OF THIS DOCUMENT IS STRICTLY PROHIBITED AND ANY INFRINGEMENT THEREUPON MAY BE SUBJECT TO LEGAL ACTION.

BOX EAVE RAFTER END WALL AND SIDE WALL OPENINGS

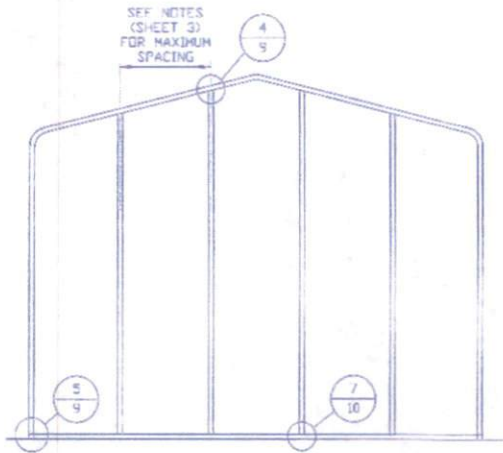

**TYPICAL BOX EAVE RAFTER
END WALL FRAMING SECTION**

SCALE: NTS

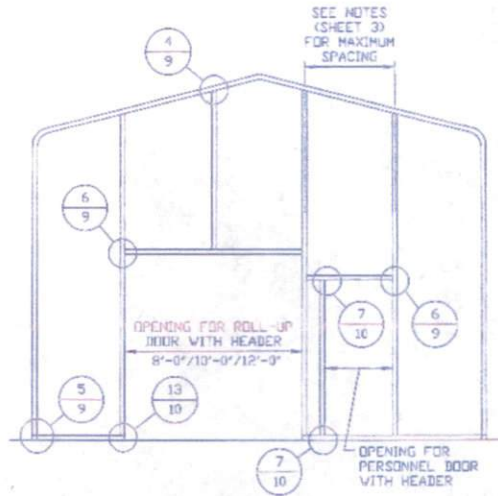

**TYPICAL BOX EAVE RAFTER END
WALL OPENINGS FRAMING SECTION**

SCALE: NTS

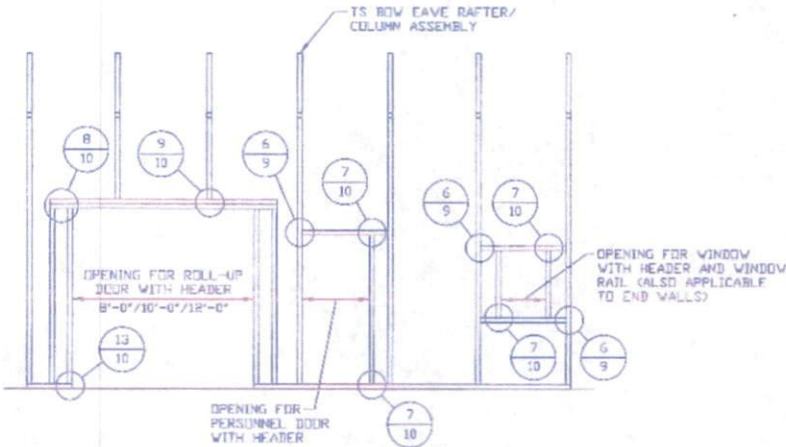

**TYPICAL BOX EAVE RAFTER
SIDE WALL OPENINGS FRAMING SECTION**

SCALE: NTS



**MOORE AND ASSOCIATES
ENGINEERING AND CONSULTING, INC.**

DRAWN BY: AT

CHECKED BY: PDH

PROJECT MGR: WSM

CLIENT: SBST

STEEL BUILDINGS AND STRUCTURES, INC.
P.O. BOX 1287,
MOUNT AIRY, NC 27030
30'-0" x 20'-0" ENCLOSED STRUCTURE

DATE: 12-14-18

SCALE: NTS

DWG. NO: SK-3

1806RS/
JOB NO: 18136S/18290S

REV: 7

THIS DOCUMENT IS THE PROPERTY OF MOORE AND ASSOCIATES ENGINEERING AND CONSULTING. THE UNAUTHORIZED REPRODUCTION, COPYING, OR OTHERWISE USE OF THIS DOCUMENT IS STRICTLY PROHIBITED AND ANY INFRINGEMENT THEREUPON MAY BE SUBJECT TO LEGAL ACTION.

CONNECTION DETAILS

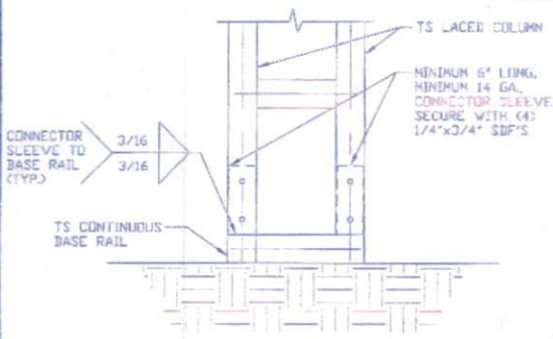

3A POST/BASE RAIL CONNECTION DETAIL
SCALE: NTS

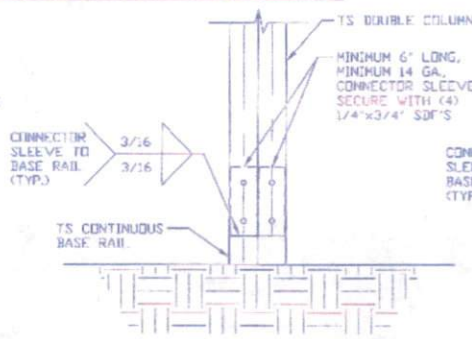

3B POST/BASE RAIL CONNECTION DETAIL
SCALE: NTS

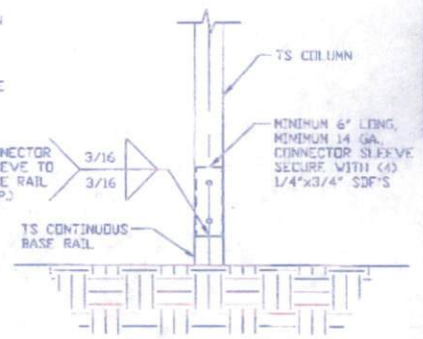

3C POST/BASE RAIL CONNECTION DETAIL
SCALE: NTS

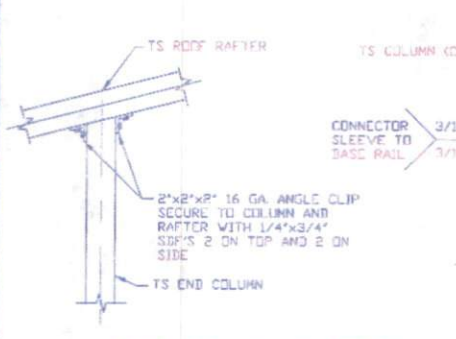

4 END COLUMN/RAFTER CONNECTION DETAIL
SCALE: NTS

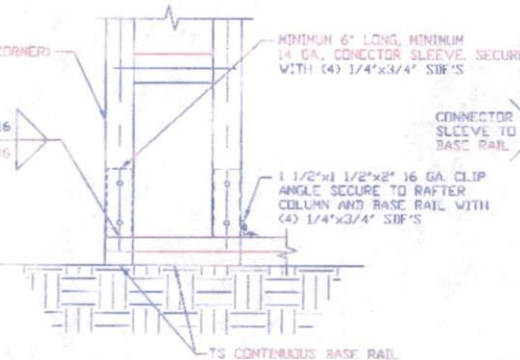

5A END COLUMN/BASE RAIL CONNECTION DETAIL
SCALE: NTS

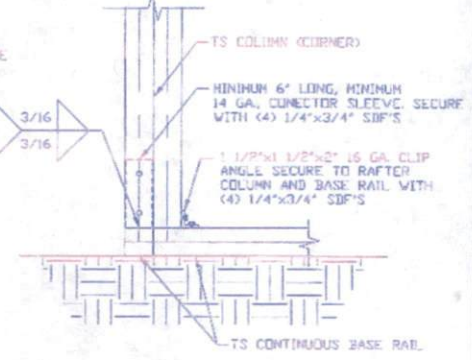

5B END COLUMN/BASE RAIL CONNECTION DETAIL
SCALE: NTS

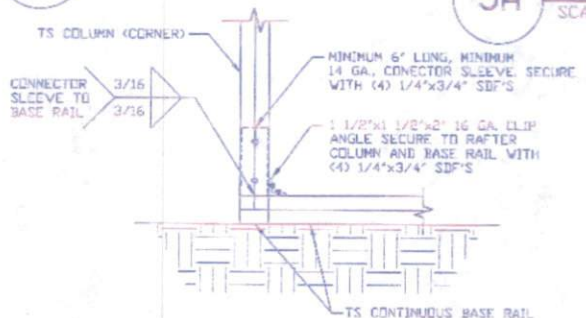

5A END COLUMN/BASE RAIL CONNECTION DETAIL
SCALE: NTS

5B END COLUMN/BASE RAIL CONNECTION DETAIL
SCALE: NTS

END COLUMN/BASE RAIL CONNECTION DETAIL

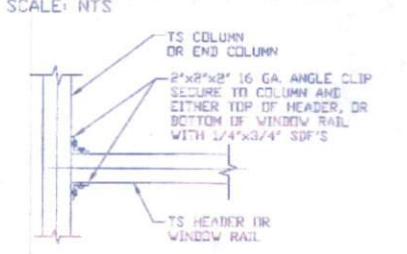

6 COLUMN OR WINDOW RAIL TO POST CONNECTION DETAIL
SCALE: NTS



MOORE AND ASSOCIATES ENGINEERING AND CONSULTING, INC.

DRAWN BY: AT		STEEL BUILDINGS AND STRUCTURES, INC.	
CHECKED BY: PDH		P.O. BOX 1287, MOUNT AIRY, NC 27030	
PROJECT NO: WSN	DATE: 12-14-18	SCALE: NTS	JOB NO: 18068S/18290S
CLIENT: SBSI	SHT. 9	DWG. NO: SK-3	REV: 7

THIS DOCUMENT IS THE PROPERTY OF MOORE AND ASSOCIATES ENGINEERING AND CONSULTING. THE UNAUTHORIZED REPRODUCTION, COPYING, OR OTHERWISE USE OF THIS DOCUMENT IS STRICTLY PROHIBITED AND ANY INFRINGEMENT THEREUPON MAY BE SUBJECT TO LEGAL ACTION.

CONNECTION DETAILS

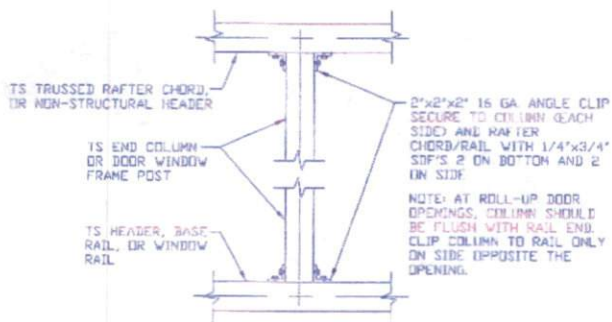

7 COLUMN TO HEADER, BASE RAIL, OR WINDOW RAIL CONNECTION DETAIL
SCALE: NTS

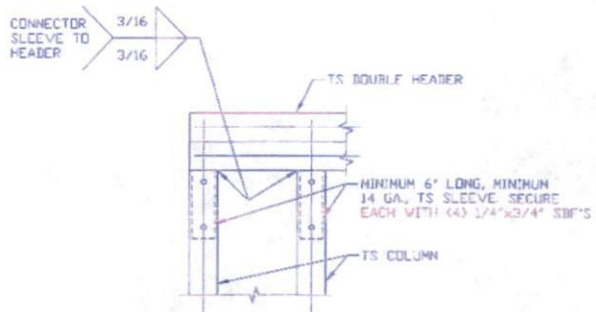

8 DOUBLE HEADER/COLUMN CONNECTION DETAIL
SCALE: NTS

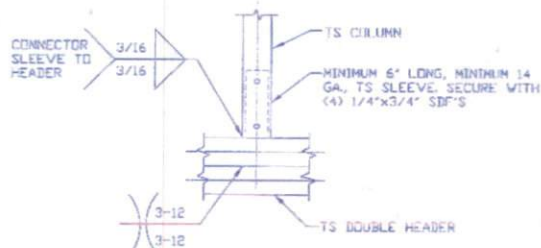

9 COLUMN/DOUBLE HEADER CONNECTION DETAIL
SCALE: NTS

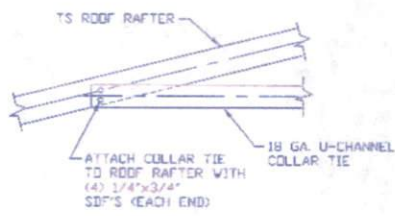

10 COLLAR TIE CONNECTION DETAIL
SCALE: NTS

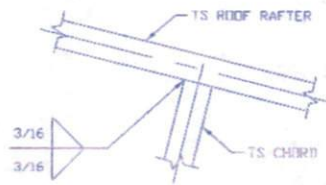

11 RAFTER TO CHORD CONNECTION DETAIL
SCALE: NTS

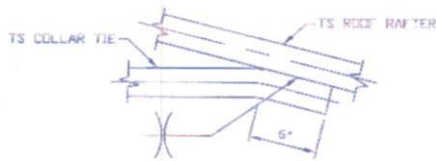

12 COLLAR TIE CONNECTION DETAIL
SCALE: NTS

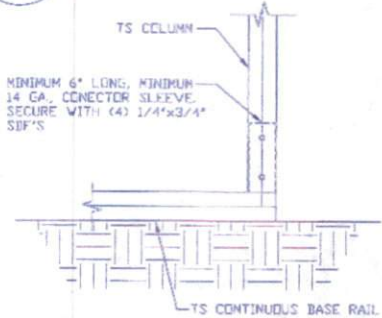

13 COLUMN/BASE RAIL CONNECTION DETAIL
SCALE: NTS



**MOORE AND ASSOCIATES
ENGINEERING AND CONSULTING, INC.**

DRAWN BY: AT
CHECKED BY: PDH
PROJECT MGR: WSM
CLIENT: SBSI

STEEL BUILDINGS AND STRUCTURES, INC.
P.O. BOX 1287,
MOUNT AIRY, NC 27030
30'-0"x20'-0" ENCLOSED STRUCTURE

DATE: 12-14-18
SHT. 10
SCALE: NTS
DWG. NO.: SK-3
JOB NO.: 18068S/18290S
REV.: 7

THIS DOCUMENT IS THE PROPERTY OF MOORE AND ASSOCIATES ENGINEERING AND CONSULTING. THE UNAUTHORIZED REPRODUCTION, COPYING, OR OTHERWISE USE OF THIS DOCUMENT IS STRICTLY PROHIBITED AND ANY INFRINGEMENT THEREUPON MAY BE SUBJECT TO LEGAL ACTION.

BOX EAVE RAFTER LEAN-TO OPTIONS

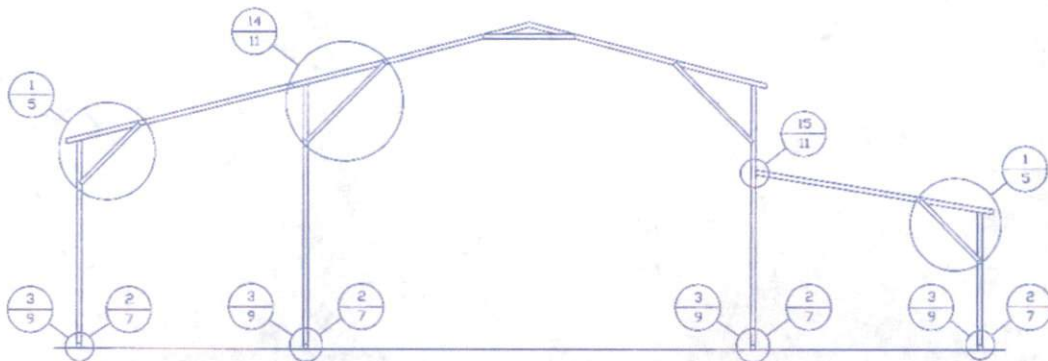

TYPICAL BOX EAVE RAFTER LEAN-TO OPTIONS FRAMING SECTION (BOTH OPTIONS SHOWN)

SCALE: NTS

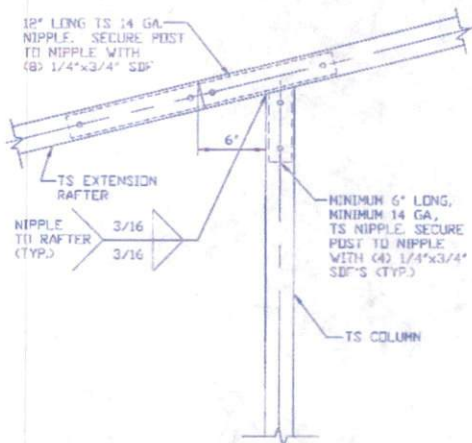

**14 SIDE EXTENSION RAFTER/
CORNER POST DETAIL**

SCALE: NTS

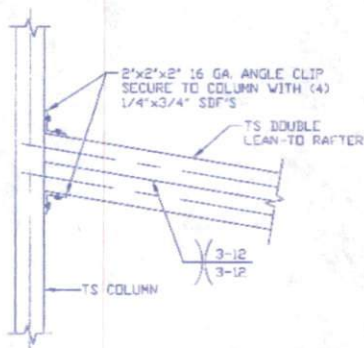

**15A LEAN-TO RAFTER TO
RAFTER POST CONNECTION
DETAIL FOR WIDTHS
12'-0" < TO ≤ 16'-0"**

SCALE: NTS

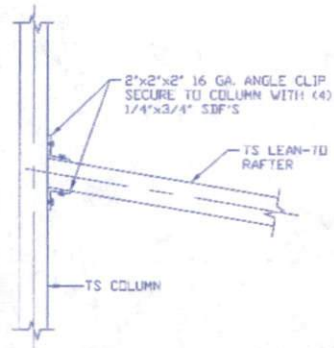

**15B LEAN-TO RAFTER
TO RAFTER POST
CONNECTION DETAIL
FOR WIDTHS ≤ 12'-0"**

SCALE: NTS



**MOORE AND ASSOCIATES
ENGINEERING AND CONSULTING, INC.**

DRAWN BY: AT

CHECKED BY: PDH

PROJECT MGR: WSM

CLIENT: SBST

STEEL BUILDINGS AND STRUCTURES, INC.

P.O. BOX 1287,
MOUNT AIRY, NC 27030

30'-0" x 20'-0" ENCLOSED STRUCTURE

DATE: 12-14-18

SCALE: NTS

JOB NO: 180685/
181565/182905

SHT. 11

DWG. NO: SK-3

REV: 7

THIS DOCUMENT IS THE PROPERTY OF MOORE AND ASSOCIATES ENGINEERING AND CONSULTING. THE UNAUTHORIZED REPRODUCTION, COPYING, OR OTHERWISE USE OF THIS DOCUMENT IS STRICTLY PROHIBITED AND ANY INFRINGEMENT THEREUPON MAY BE SUBJECT TO LEGAL ACTION.

BOW EAVE RAFTER LEAN-TO OPTIONS

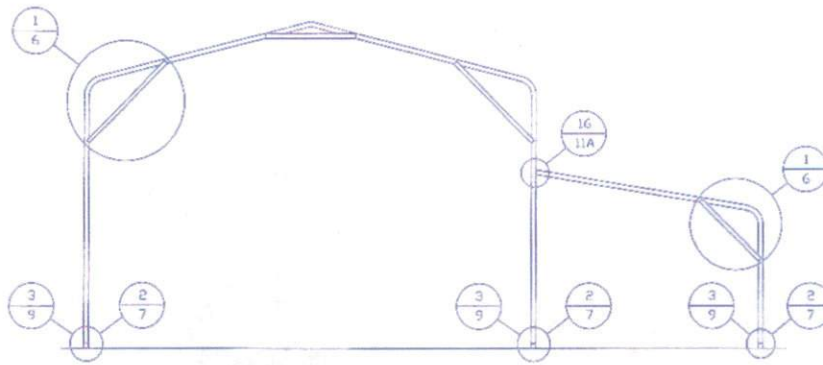

TYPICAL BOW EAVE RAFTER LEAN-TO OPTIONS FRAMING SECTION
SCALE: NTS

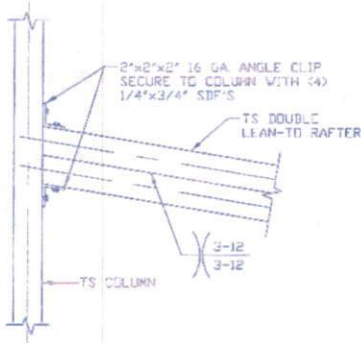

**LEAN-TO RAFTER TO
RAFTER POST CONNECTION
DETAIL FOR WIDTHS
12'-0" < TO ≤ 16'-0"**

16A

SCALE: NTS

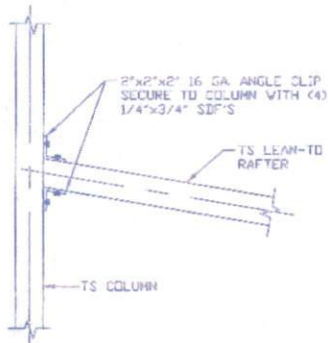

**LEAN-TO RAFTER
TO RAFTER POST
CONNECTION DETAIL
FOR WIDTHS ≤ 12'-0"**

16B

SCALE: NTS



**MOORE AND ASSOCIATES
ENGINEERING AND CONSULTING, INC.**

DRAWN BY: AT

CHECKED BY: PDH

PROJECT MGR: VSM

CLIENT: SBST

STEEL BUILDINGS AND STRUCTURES, INC.
P.O. BOX 1287,
MOUNT AIRY, NC 27030
30'-0"x20'-0" ENCLOSED STRUCTURE

DATE: 12-14-18

SHT. 11A

SCALE: NTS

DWG NO SK-3

JOB NO: 180685/
181565/182903

REV: 7

THIS DOCUMENT IS THE PROPERTY OF MOORE AND ASSOCIATES ENGINEERING AND CONSULTING. THE UNAUTHORIZED REPRODUCTION, COPYING, OR OTHERWISE USE OF THIS DOCUMENT IS STRICTLY PROHIBITED AND ANY INFRINGEMENT THEREUPON MAY BE SUBJECT TO LEGAL ACTION.

BOX EAVE RAFTER VERTICAL ROOF/SIDING OPTION

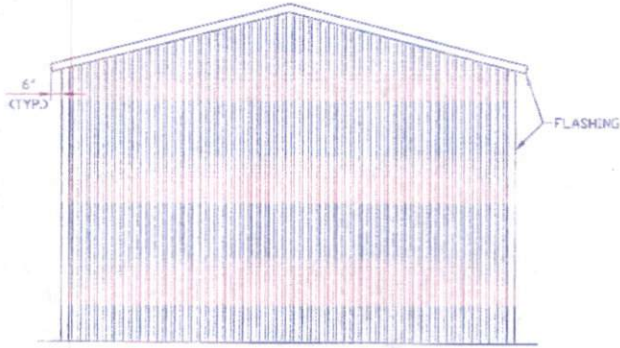

**TYPICAL END ELEVATION
VERTICAL ROOF/SIDING**

SCALE: NTS

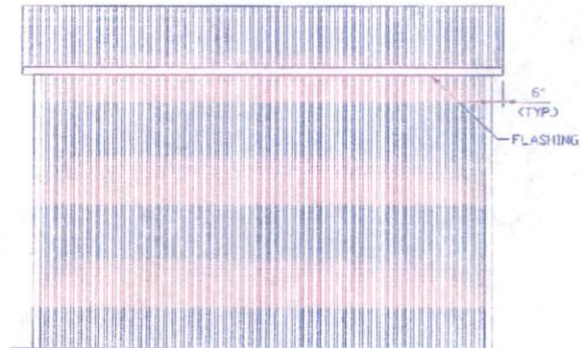

**TYPICAL SIDE ELEVATION
VERTICAL ROOF/SIDING**

SCALE: NTS

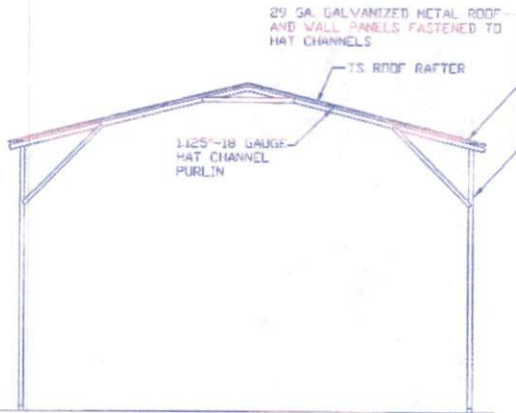

**TYPICAL SECTION
VERTICAL ROOF/SIDING OPTION**

SCALE: NTS

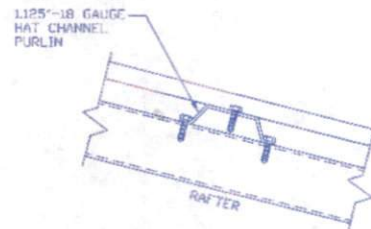

PANEL ATTACHMENT

(ALTERNATE FOR VERTICAL ROOF PANELS)
SCALE: NTS

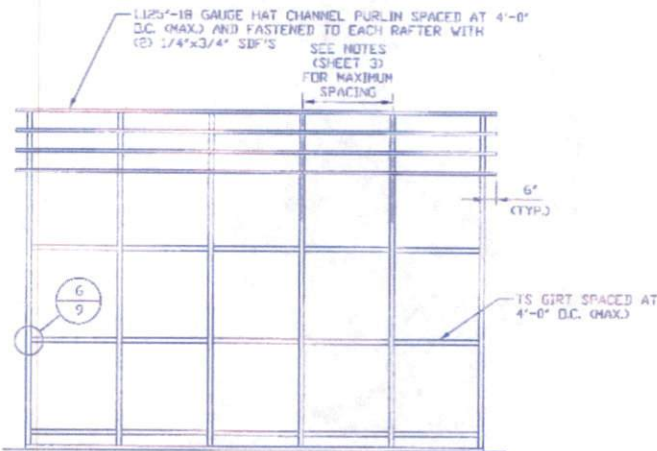

**TYPICAL FRAMING SECTION
VERTICAL ROOF/SIDING OPTION**

SCALE: NTS

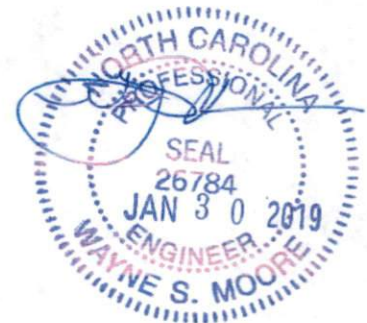

**MOORE AND ASSOCIATES
ENGINEERING AND CONSULTING, INC.**

DRAWN BY: AT

CHECKED BY: PDH

PROJECT MGR: VSH

CLIENT: SBSI

STEEL BUILDINGS AND STRUCTURES, INC.
P.O. BOX 1287,
MOUNT AIRY, NC 27030
30'-0" x 20'-0" ENCLOSED STRUCTURE

DATE: 12-14-18

SCALE: NTS

JOB NO: 180685/182903

SHT. 12

IMG. NO: SK-3

REV: 6A

THIS DOCUMENT IS THE PROPERTY OF MOORE AND ASSOCIATES ENGINEERING AND CONSULTING. THE UNAUTHORIZED REPRODUCTION, COPYING, OR OTHERWISE USE OF THIS DOCUMENT IS STRICTLY PROHIBITED AND ANY INFRINGEMENT THEREUPON MAY BE SUBJECT TO LEGAL ACTION.

OPTIONAL HEADER

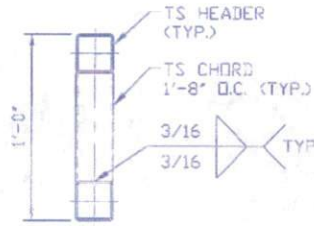

HEADER DETAIL FOR DOOR
OPENINGS 12'-0" < LENGTH < 20'-0"
 SCALE: NTS

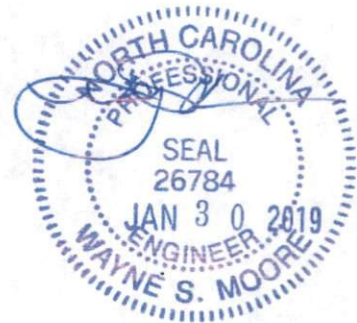

**MOORE AND ASSOCIATES
 ENGINEERING AND CONSULTING, INC.**

DRAWN BY: AT

CHECKED BY: PDH

PROJECT MGR: WSM

CLIENT: SBSE

STEEL BUILDINGS AND STRUCTURES, INC.
 P.O. BOX 1287,
 MOUNT AIRY, NC 27030
 30'-0" x 20'-0" ENCLOSED STRUCTURE

DATE: 12-14-18

SHT. 13

SCALE: NTS

IMG. NO: SK-3

**JOB NO: 18068S/
 18156S/18290S**

REV: 7

THIS DOCUMENT IS THE PROPERTY OF MOORE AND ASSOCIATES ENGINEERING AND CONSULTING. THE UNAUTHORIZED REPRODUCTION, COPYING, OR OTHERWISE USE OF THIS DOCUMENT IS STRICTLY PROHIBITED AND ANY INFRINGEMENT THEREUPON MAY BE SUBJECT TO LEGAL ACTION.

ADDITIONAL BASE RAIL ANCHORAGE OPTION

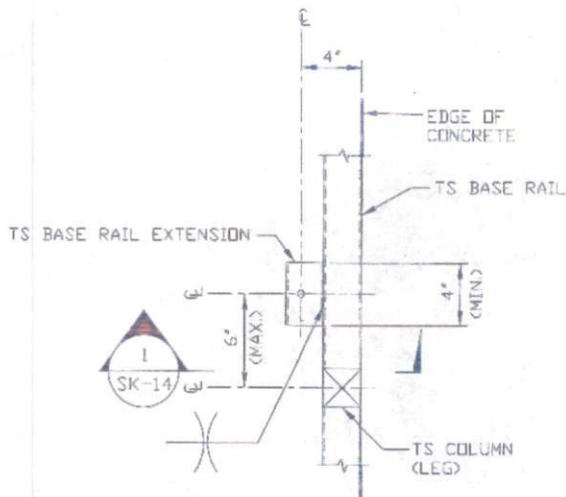

TYPICAL ANCHOR DETAIL WHEN BASE RAIL IS NEAR EDGE OF CONCRETE

SCALE: NTS

SECTION 1
SCALE: NTS

SK-14

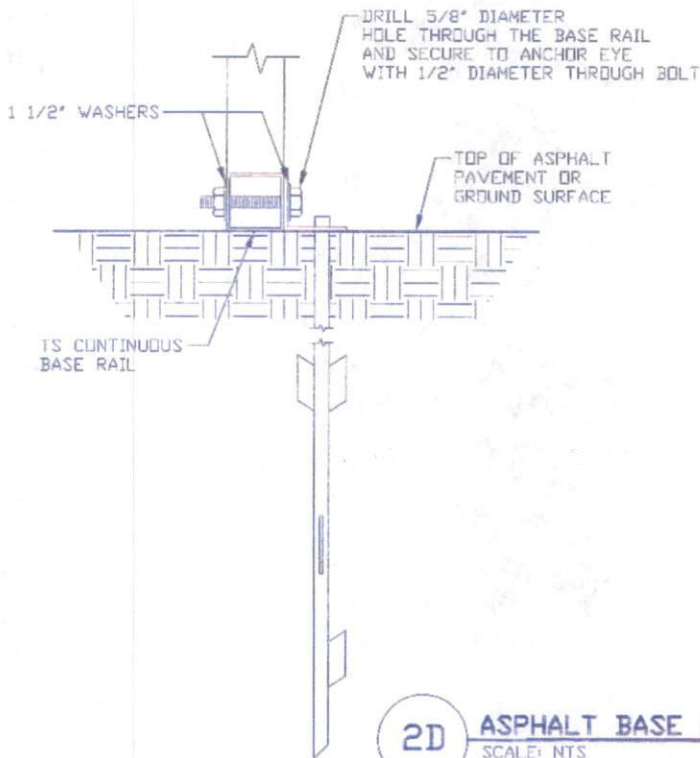

2D

ASPHALT BASE ANCHORAGE

SCALE: NTS



**MOORE AND ASSOCIATES
ENGINEERING AND CONSULTING, INC.**

DRAWN BY: AT

CHECKED BY: PDH

PROJECT MGR: VSM

CLIENT: SBSI

STEEL BUILDINGS AND STRUCTURES, INC.

P.O. BOX 1287,
MOUNT AIRY, NC 27030

30'-0" x 20'-0" ENCLOSED STRUCTURE

DATE: 12-14-18

SCALE: NTS

DWG NO SK-3

JOB NO: 18068S/
18156S/18290S

SHT. 14

REV: 7

THIS DOCUMENT IS THE PROPERTY OF MOORE AND ASSOCIATES ENGINEERING AND CONSULTING. THE UNAUTHORIZED REPRODUCTION, COPYING, OR OTHERWISE USE OF THIS DOCUMENT IS STRICTLY PROHIBITED AND ANY INFRINGEMENT THEREUPON MAY BE SUBJECT TO LEGAL ACTION.

OPTIONAL BASE RAIL ON GRADE APPLICATION

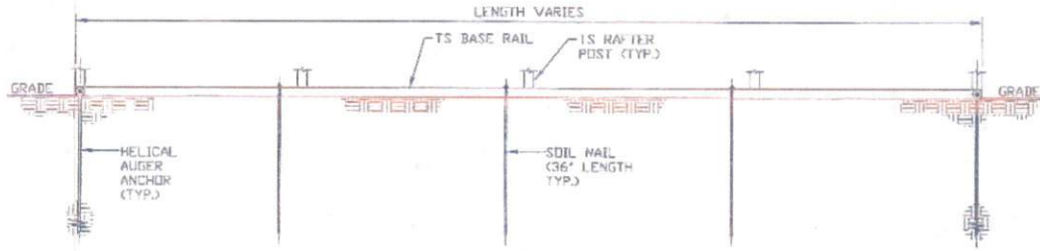

SECTION 2
SCALE: NTS
SK-15

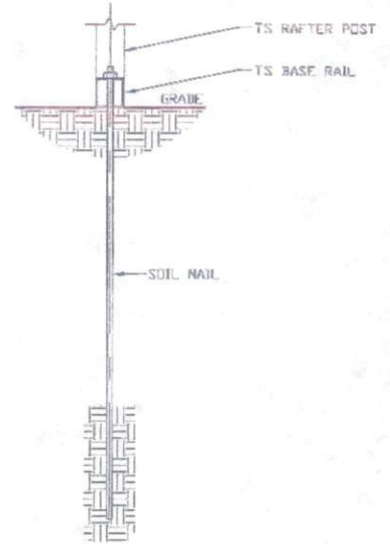

SECTION 1
SCALE: NTS
SK-15

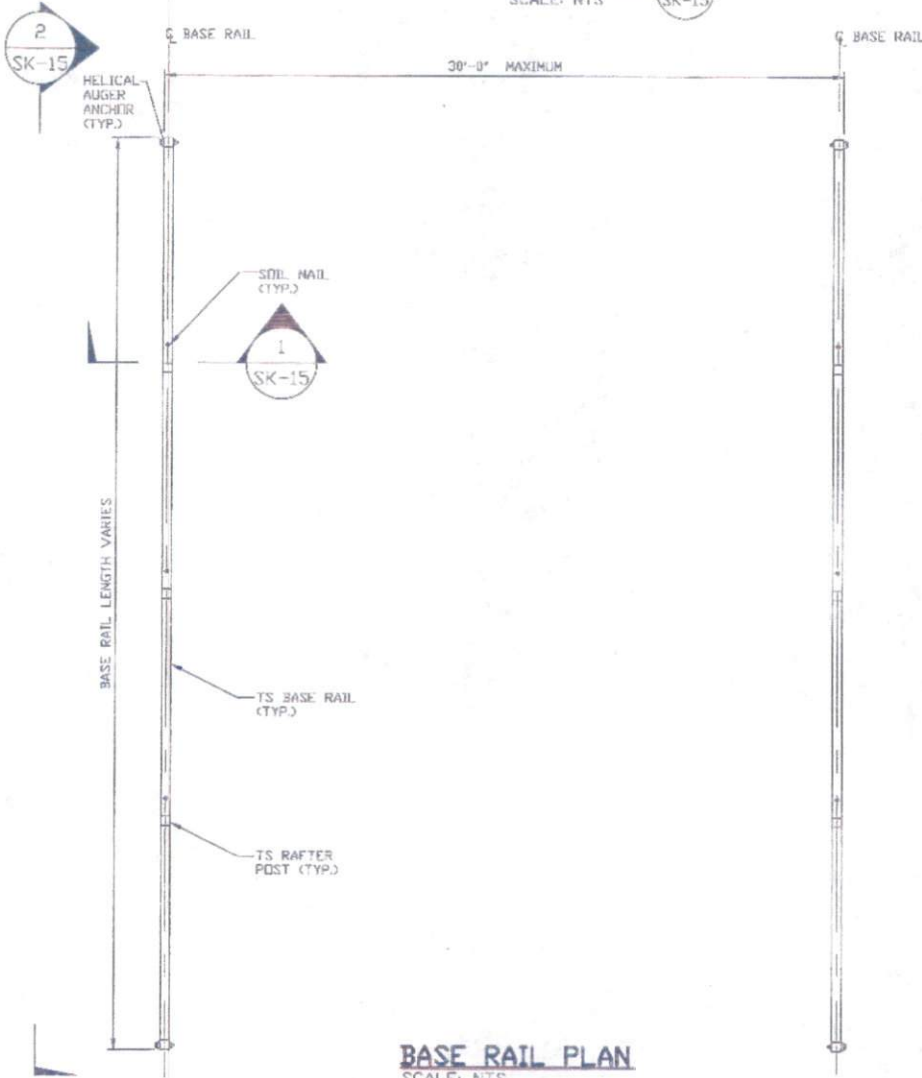

BASE RAIL PLAN
SCALE: NTS

HELIX ANCHOR	
SIDE LENGTH	MAXIMUM SPACING
VARIES	10'-0" (EVERY OTHER POST)



**MOORE AND ASSOCIATES
ENGINEERING AND CONSULTING, INC.**

DRAWN BY: AT
CHECKED BY: PDH

STEEL BUILDINGS AND STRUCTURES, INC.
P.O. BOX 1287,
MOUNT AIRY, NC 27030
30'-0" x 20'-0" ENCLOSED STRUCTURE

THIS DOCUMENT IS THE PROPERTY OF MOORE AND ASSOCIATES ENGINEERING AND CONSULTING. THE UNAUTHORIZED REPRODUCTION, COPYING, OR OTHERWISE USE OF THIS DOCUMENT IS STRICTLY PROHIBITED AND ANY INFRINGEMENT THEREUPON MAY BE SUBJECT TO LEGAL ACTION.

PROJECT NO: WSM
CLIENT: SBSI

DATE: 12-14-18
SHT. 15

SCALE: NTS
JWG. NO: SK-3

JOB NO: 180682/181565/182905
REV: 7

OPTIONAL BASE RAIL ON TIMBER BEAM

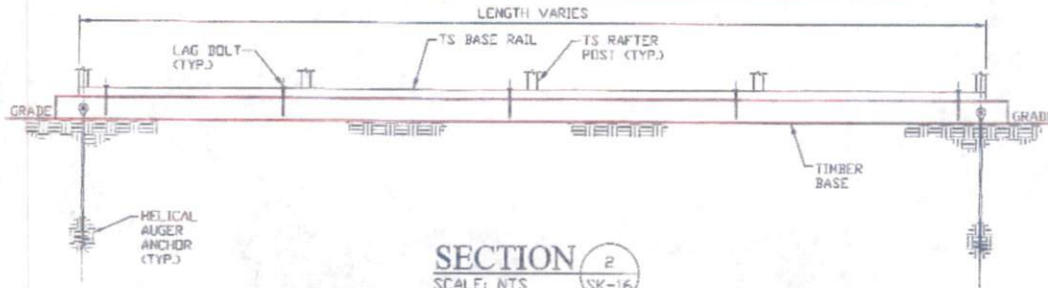

SECTION 2
SCALE: NTS (SK-16)

2
SK-16

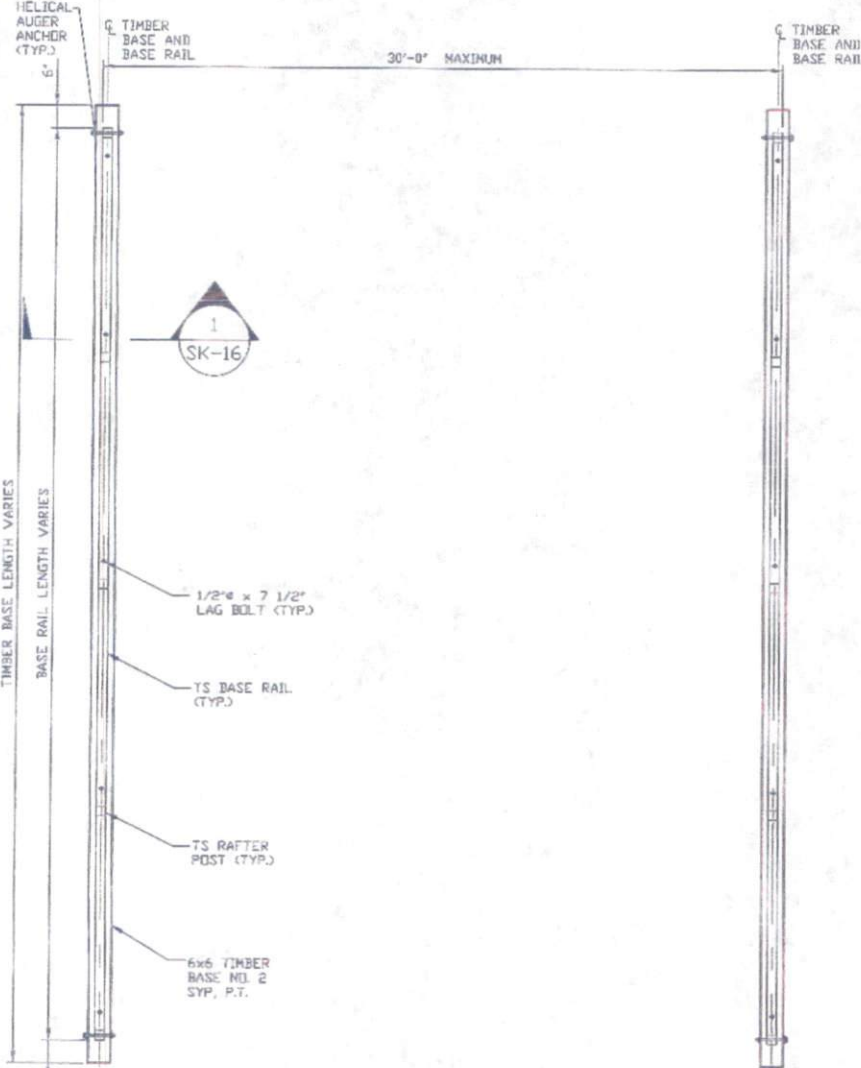

1
SK-16

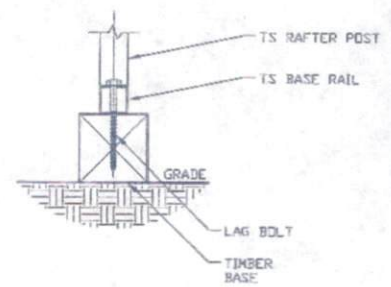

SECTION 1
SCALE: NTS (SK-16)

TIMBER FOOTING PLAN
SCALE: NTS

HELIX ANCHOR	
SIDE LENGTH	MAXIMUM SPACING
VARIES	10'-0" (EVERY OTHER POST)



**MOORE AND ASSOCIATES
ENGINEERING AND CONSULTING, INC.**

DRAWN BY: AT

CHECKED BY: PDH

PROJECT MGR: WSM

CLIENT: SBST

STEEL BUILDINGS AND STRUCTURES, INC.
P.O. BOX 1287,
MOUNT AIRY, NC 27030
30'-0" x 20'-0" ENCLOSED STRUCTURE

DATE: 12-14-18

SCALE: NTS

JOB NO: 180685/
181565/182905

SHT. 16

DWG. NO: SK-3

REV: 7

THIS DOCUMENT IS THE PROPERTY OF MOORE AND ASSOCIATES ENGINEERING AND CONSULTING. THE UNAUTHORIZED REPRODUCTION, COPYING, OR OTHERWISE USE OF THIS DOCUMENT IS STRICTLY PROHIBITED AND ANY INFRINGEMENT THEREUPON MAY BE SUBJECT TO LEGAL ACTION.

OPTIONAL BASE RAIL ON TIMBER BEAM WITH SOIL NAIL

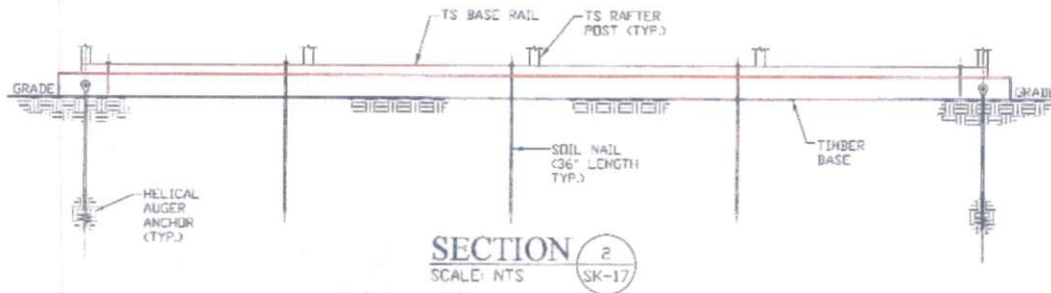

SECTION 2
SCALE: NTS

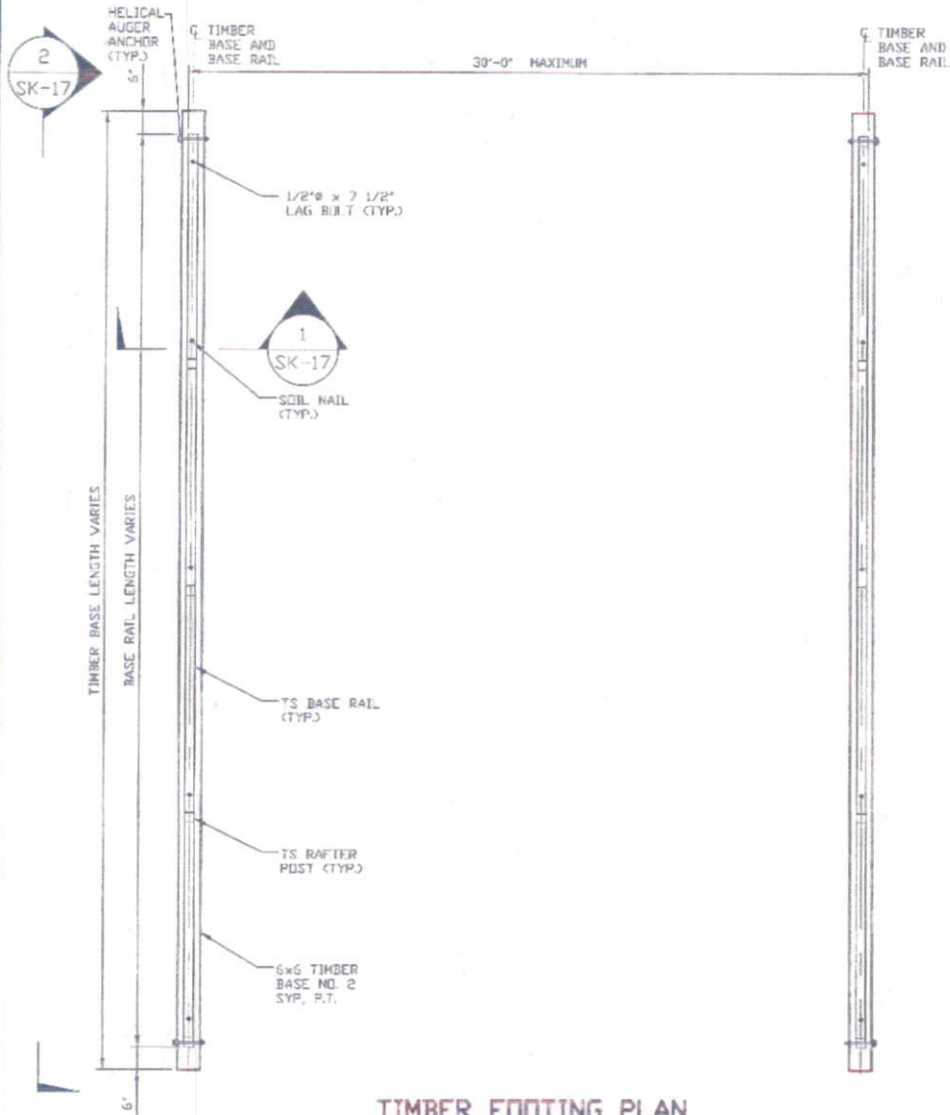

TIMBER FOOTING PLAN
SCALE: NTS

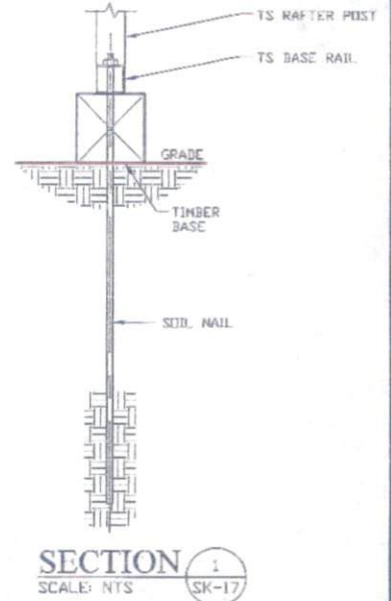

SECTION 1
SCALE: NTS

HELIX ANCHOR	
SIDE LENGTH	MAXIMUM SPACING
VARIES	10'-0" (EVERY OTHER POST)



MOORE AND ASSOCIATES
ENGINEERING AND CONSULTING, INC.

DRAWN BY: AT
CHECKED BY: PJH
PROJECT MGR: WSM
CLIENT: SBST

STEEL BUILDINGS AND STRUCTURES, INC.
P.O. BOX 1287,
MOUNT AIRY, NC 27030
30'-0" x 20'-0" ENCLOSED STRUCTURE

DATE 12-14-18	SCALE NTS	JOB NO. 18068/ 181565/18290S
SHT. 17	DWG. NO. SK-3	REV. 7

THIS DOCUMENT IS THE PROPERTY OF MOORE AND ASSOCIATES ENGINEERING AND CONSULTING. THE UNAUTHORIZED REPRODUCTION, COPYING, OR OTHERWISE USE OF THIS DOCUMENT IS STRICTLY PROHIBITED AND ANY INFRINGEMENT THEREUPON MAY BE SUBJECT TO LEGAL ACTION.

OPTIONAL CONCRETE STRIP FOOTING

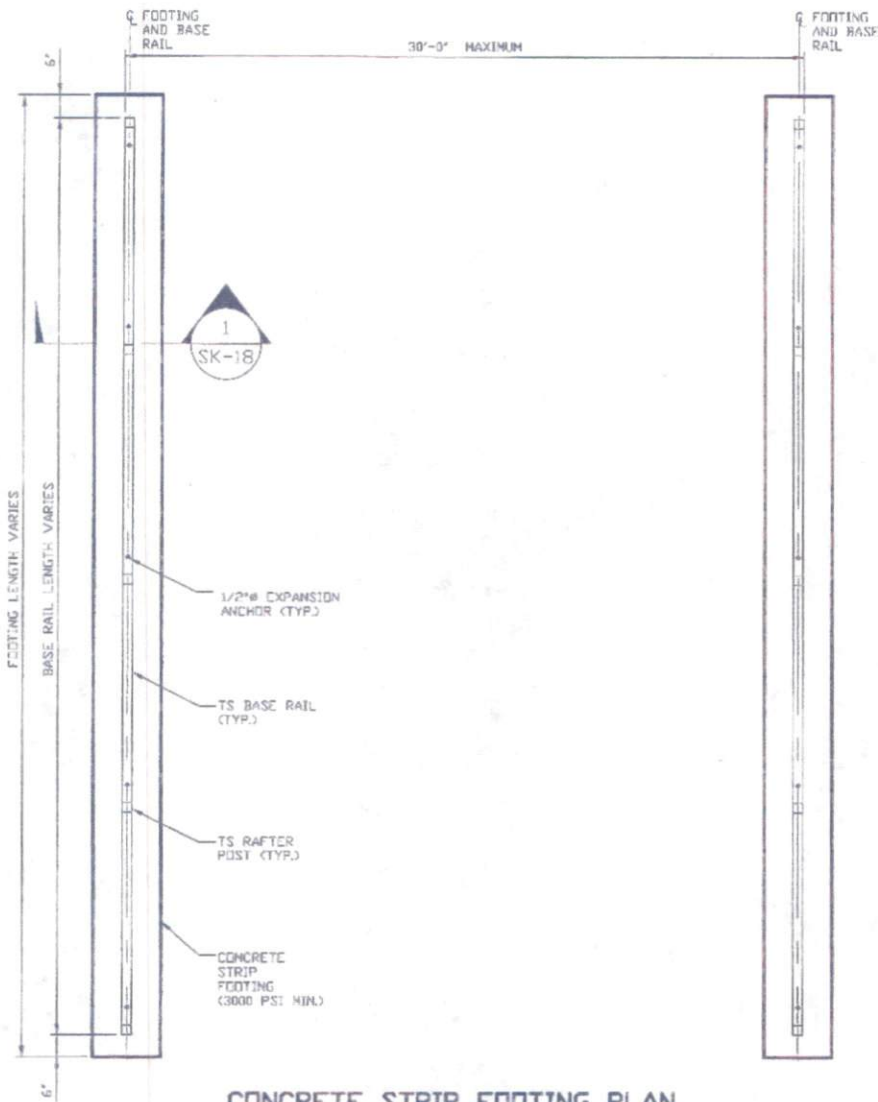

CONCRETE STRIP FOOTING PLAN
SCALE: NTS

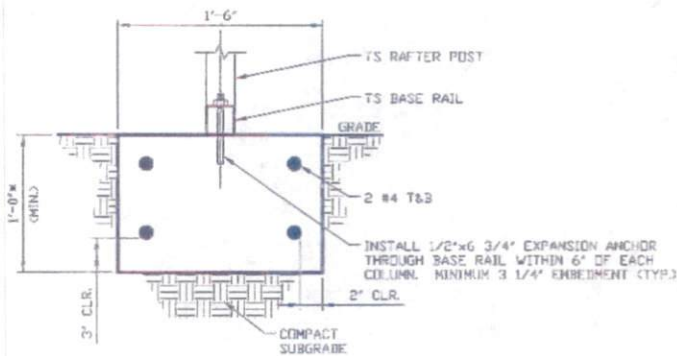

SECTION 1
SCALE: NTS 1 SK-18

■ COORDINATE WITH LOCAL CODES/ORD.



**MOORE AND ASSOCIATES
ENGINEERING AND CONSULTING, INC.**

DRAWN BY: AT

CHECKED BY: PDH

PROJECT MGR: WSM

CLIENT: SBST

STEEL BUILDINGS AND STRUCTURES, INC.
P.O. BOX 1287,
MOUNT AIRY, NC 27030
30'-0" x 20'-0" ENCLOSED STRUCTURE

DATE: 12-14-18

SCALE: NTS

DWG. NO: SK-3

JOB NO: 180685/18156S/18290S

REV: 7

THIS DOCUMENT IS THE PROPERTY OF MOORE AND ASSOCIATES ENGINEERING AND CONSULTING. THE UNAUTHORIZED REPRODUCTION, COPYING, OR OTHERWISE USE OF THIS DOCUMENT IS STRICTLY PROHIBITED AND ANY INFRINGEMENT THEREUPON MAY BE SUBJECT TO LEGAL ACTION.