

CEILING HEIGHTS
 EXISTING 7'-6"
 HALLWAY 8'-0"
 BEDROOMS AND CLOSETS 8'-0"

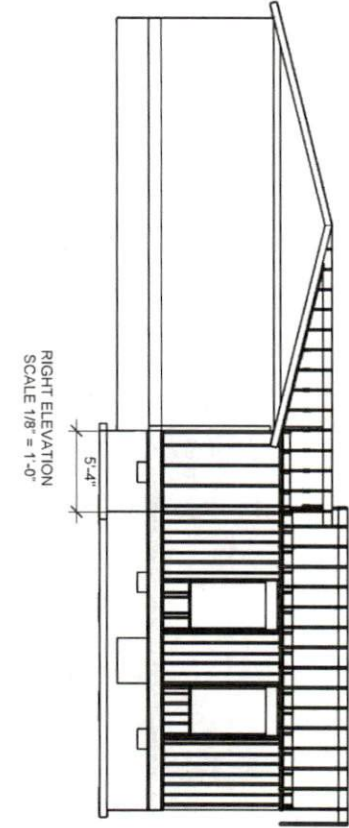

01 S	ENGINEER Ronald L. Knott, P.E. 801 Cricket Knoll Rd Fuquay Varina, NC 27526 (919)417-1962	DESCRIPTION OVERVIEW ELEVATIONS	ISSUE 8.7.2019	CLIENT Juan Carlos & Darlene Leon 76 Virginia Lane Cameron, NC	BEDROOM ADDITION LOCATION 76 Virginia Lane	
-----------------------	---	---------------------------------------	-------------------	---	--	---

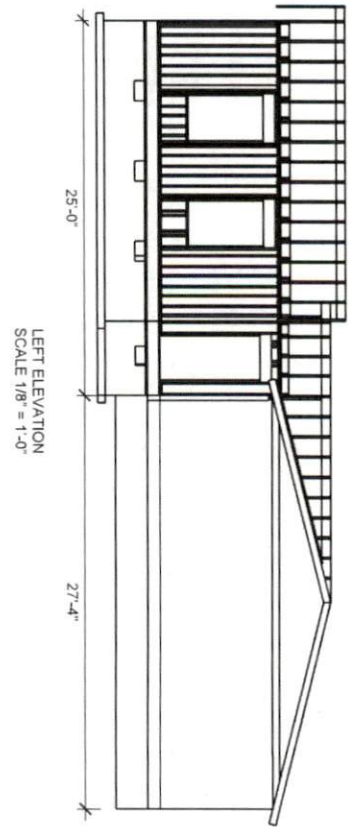
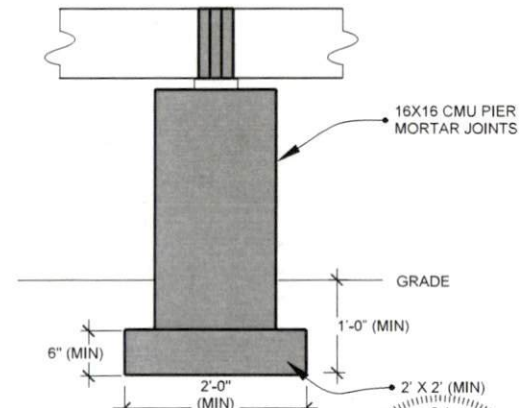
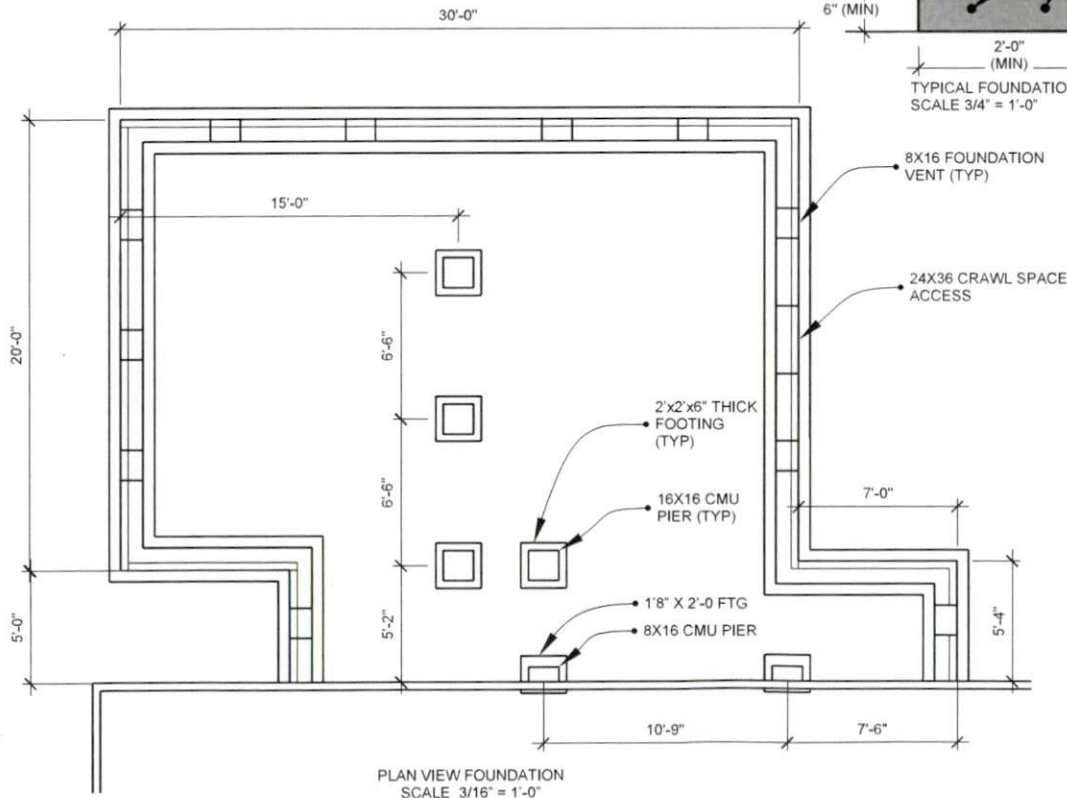
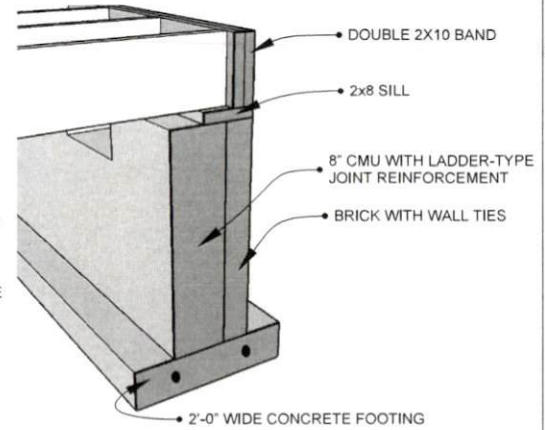
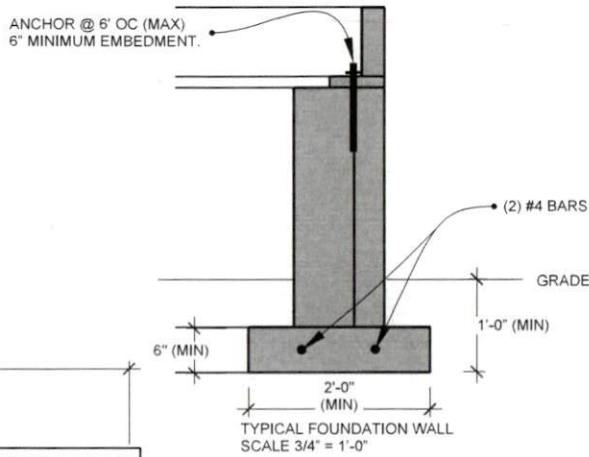
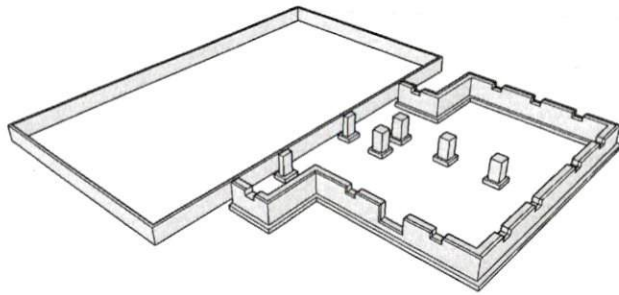

PIER DETAIL
SCALE 3/4" = 1'-0"
SIMILAR FOR 8X16 PIER



BEDROOM ADDITION
LOCATION
76 Virginia Lane

CLIENT
Juan Carlos & Darlene Leon
76 Virginia Lane
Cameron, NC

ISSUE
8.7.2019

FOUNDATION PLAN

ENGINEER
Ronald L. Knott, P.E.
801 Cricket Knoll Rd
Fuquay Varina, NC 27526
(919)417-1962

S
02

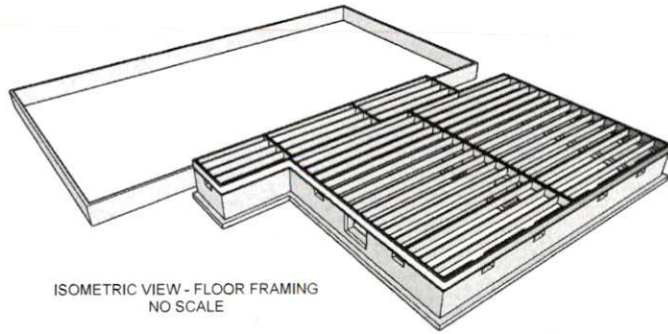

ISOMETRIC VIEW - FLOOR FRAMING
NO SCALE

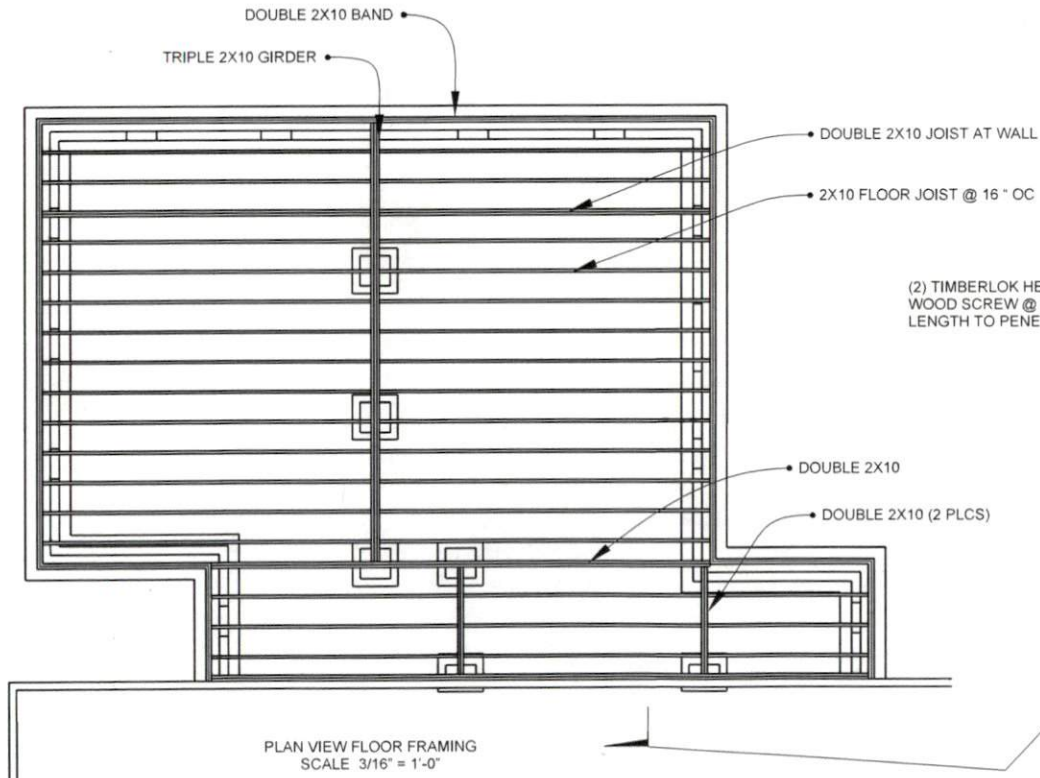

NOTES:

FLOOR JOISTS SPF NO. 2

MASONRY STOOP WITH 4'-0" X 4'-0" LANDING FOR EACH ENTRANCE.

OPTIONAL IN LIEU OF MASONRY STOOP:
WOODEN FREESTANDING PT DECK AT EACH ENTRANCE
4'-0" X 4'-0" MINIMUM LANDING WITH (4) 4X4 POSTS, 2X8 BAND AND
2X6 JOISTS ON LEDGERS AT 16" OC. MIN 5/4 X 6 DECKING BOARDS.
POSTS EMBEDDED IN CONCRETE 12" DIA X 1'-0" MIN. (3) STINGERS
FROM 2X12s FOR EACH STAIR.

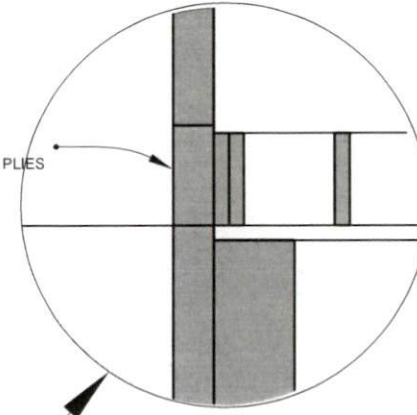

SECTION AT HOUSE TO NEW GIRDER
SCALE 1" = 1'-0"



RLK

BEDROOM ADDITION
LOCATION
76 Virginia Lane

CLIENT
Juan Carlos & Darlene Leon
76 Virginia Lane
Cameron, NC

ISSUE
8.7.2019

FLOOR FRAMING PLAN

ENGINEER
Ronald L. Knott, P.E.
801 Cricket Knoll Rd
Fuquay Varina, NC 27526
(919)417-1962

S

03



BEDROOM ADDITION
 LOCATION
 76 Virginia Lane

CLIENT
 Juan Carlos & Darlene Leon
 76 Virginia Lane
 Cameron, NC

ISSUE
 8.7.2019

WALL FRAMING PLAN

ENGINEER
 Ronald L Knott, P.E.
 801 Cricket Knoll Rd
 Fuquay Varina, NC 27526
 (919)417-1962

S
04

NOTES:
 2X4 STUDS SPF.
 DOUBLE 2X10 HEADER FOR ALL WINDOWS AND DOORS WITH
 SINGLE JACK AND KING STUD EACH SIDE (MIN)

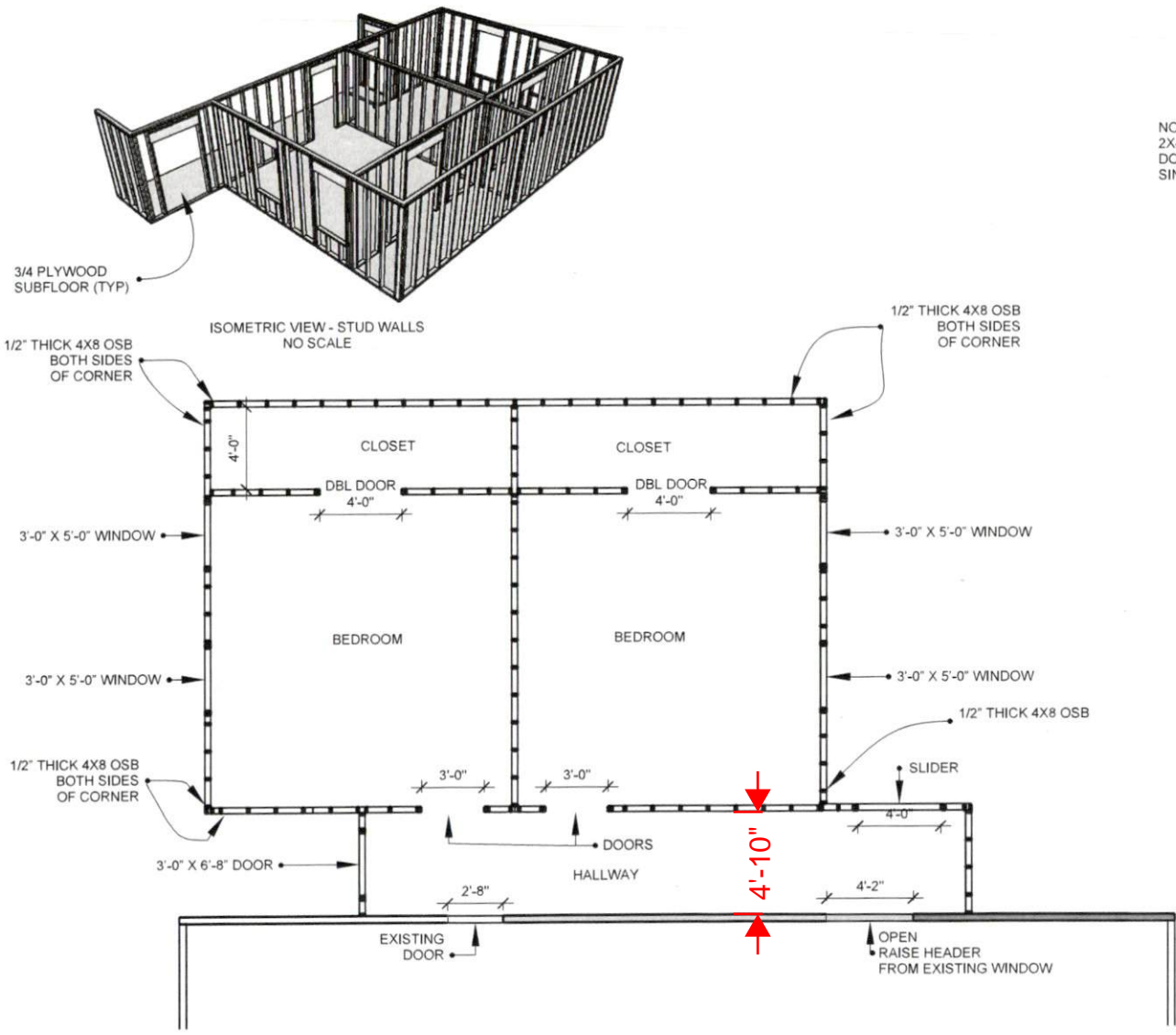

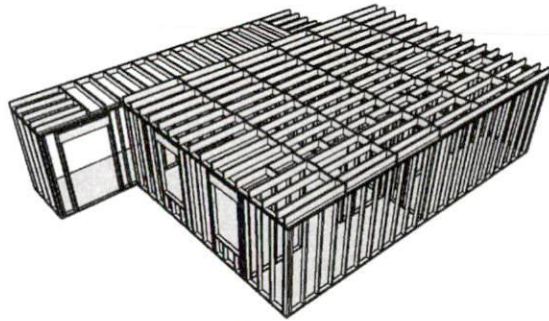

ISOMETRIC VIEW - CEILING FRAMING
NO SCALE

NOTES:
CEILING JOISTS SPF NO. 2

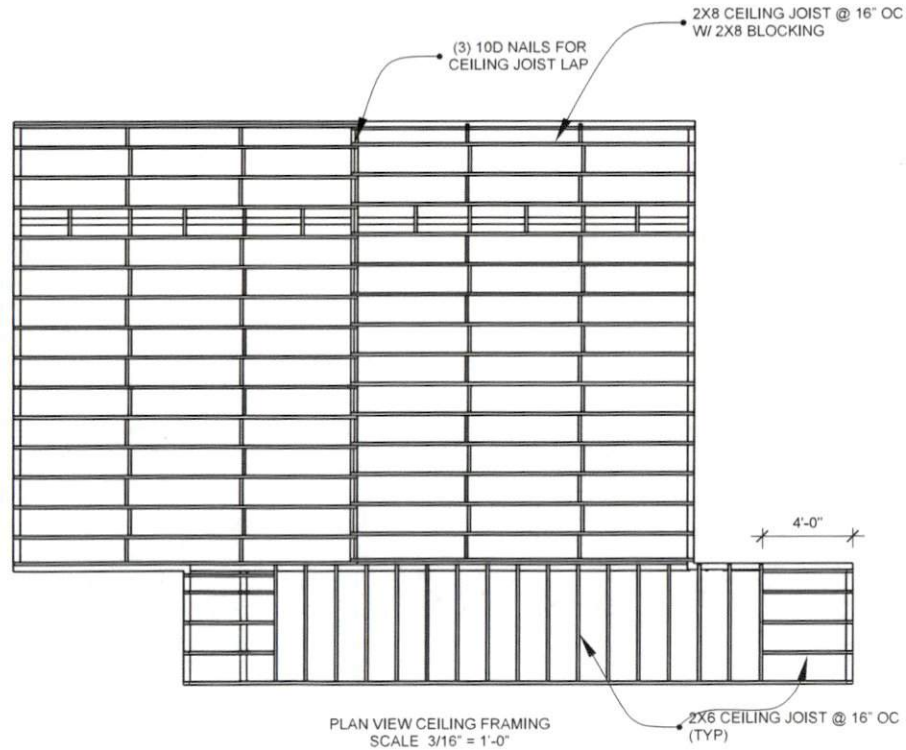

PLAN VIEW CEILING FRAMING
SCALE 3/16" = 1'-0"



BEDROOM ADDITION
LOCATION
76 Virginia Lane

CLIENT
Juan Carlos & Darlene Leon
76 Virginia Lane
Cameron, NC

ISSUE
8.7.2019

FOUNDATION PLAN

ENGINEER
Ronald L Knott, P.E.
801 Cricket Knoll Rd
Fuquay Varina, NC 27526
(919)417-1962

S
05

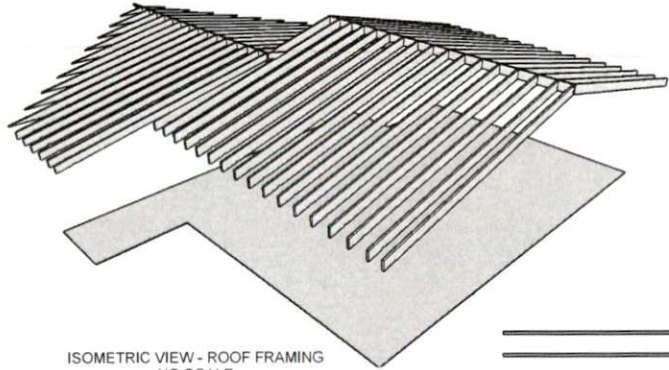

ISOMETRIC VIEW - ROOF FRAMING
NO SCALE

NOTES:
RAFTERS SPF NO. 2

2X6 RAFTERS @ 16" OC
WITH 2X8 RIDGE BOARD

2X4 JACKS ON EXISTING
WALL SUPPORTING NEW RIDGE
AND NEW RAFTERS

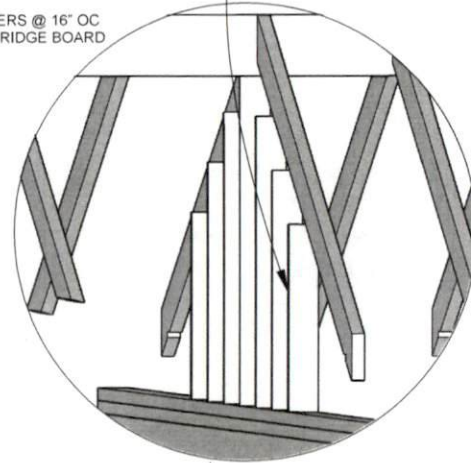

ISO VIEW JACKS
UNDER RIDGE AND RAFTER
NO SCALE

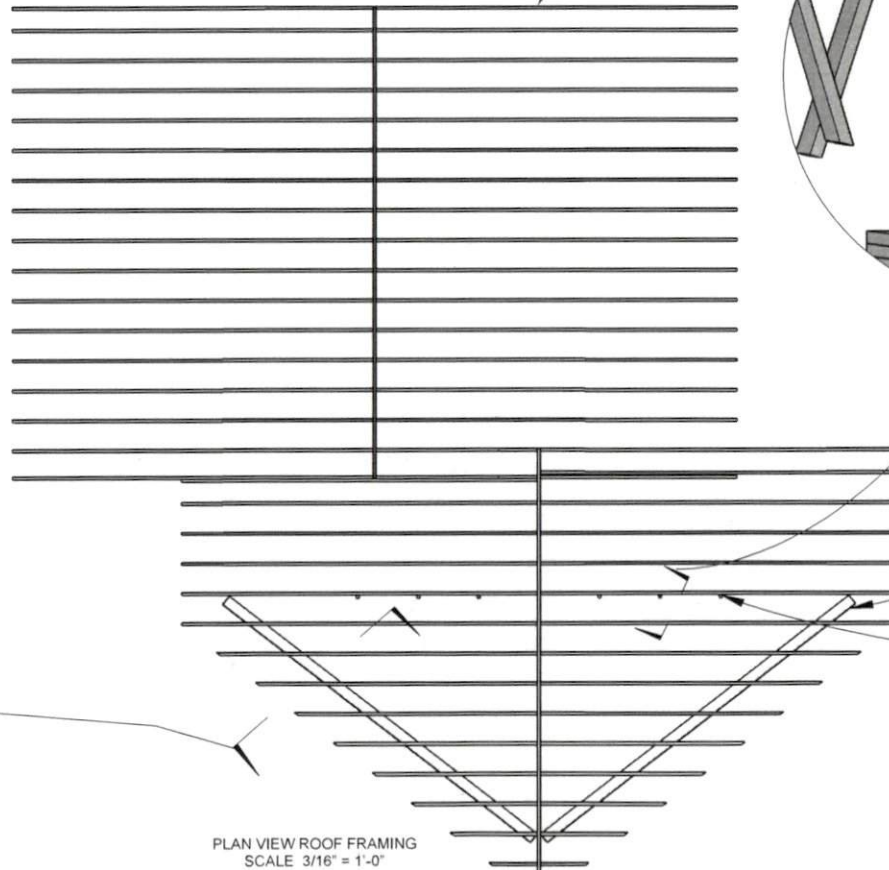

PLAN VIEW ROOF FRAMING
SCALE 3/16" = 1'-0"

2X6 SLEEPER UNDER
RAFTERS ON EXISTING ROOF

2X4 POST TO EXISTING
BACK WALL OF HOUSE

TOENAIL TO SLEEPER
(2) 10D

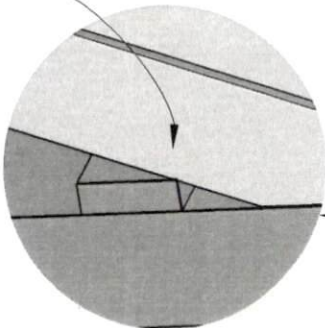

SECTION THROUGH SLEEPER
SCALE 1" = 1'-0"



AL

BEDROOM ADDITION
LOCATION
76 Virginia Lane

CLIENT
Juan Carlos & Darlene Leon
76 Virginia Lane
Cameron, NC

ISSUE
8.7.2019

ROOF FRAMING PLAN

ENGINEER
Ronald L. Knott, P.E.
801 Cricket Knoll Rd
Fuquay Varina, NC 27526
(919)417-1962

S

06