

Date: May 29, 2026  
Project: McDonald Property  
Address: 530 Peach Farm Rd  
Lillington, NC 27546

Foundation Support Systems Analysis

This report is prepared for Southeast Foundation Repair (contractor) by FDN Engineering (engineer). Helical piers are proposed for installation at the above referenced project. The foundation support system is intended to stabilize and potentially lift the existing foundation structure – reducing pressure on existing soils. Load requirements for the systems were calculated at areas shown on the repair plan. Engineer performed design for this project - see page 2 for engineering notes and results. See page 3 for details of the repair systems. See page 4 for a repair plan of the foundation support systems on the structure.

To the best of my professional knowledge, the design of the helical pier foundation support systems meets the structural requirements of the 2018 North Carolina State Building Code to the extent that it applies to our scope of work. Engineer is retained in a limited capacity for this project. No responsibility and/or liability is assumed by, nor shall be assigned to engineer for items beyond the proposed scope as shown herein. The specified scope area may not address all areas requiring attention.

Upon completion of the foundation support systems, the contractor shall supply engineer a log of the installed locations, depth, and final torque of the helical piers, as well as photos of completed work. Engineer will evaluate the field data and prepare a letter of completion for closeout, if necessary.

FDN Engineering, PLLC  
2412 N 179th St.  
Omaha, NE 68116  
(402) 739-9642

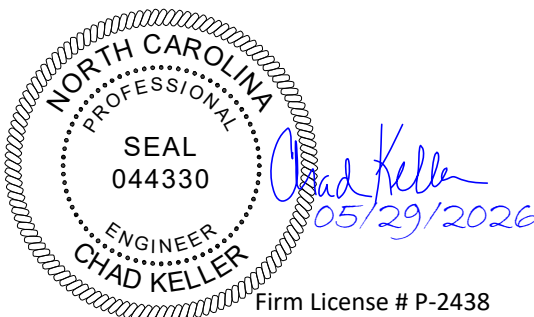

Helical Pier Project Notes (contractor to inform engineer if discrepancies are found):

- A.1 Structure is one-story, commercial with wood-framed floor & brick-veneer walls.
- A.2 Contractor will install helical piers, brackets, and all related components per the support manufacturer's current installation instructions and technical manual, and according to the latest ICC-ES AC358 & ESR-3074.
- A.3 Helical piers shall have a center-to-center spacing at the helix depth of at least three (3) times the diameter of the largest helix plate.
- A.4 Pier shall not be installed in recently backfilled sites, in bedrock soils, or where there is possible sinkhole activity. Notify engineer if foundation is cracked between piers.
- A.5 The pier was designed as plain steel corroded with capacities assuming a 50-year scheduled sacrificial loss in thickness per ICC-ES AC406. Contractor may galvanize the system for added corrosion protection.
- A.6 Only local effects have been checked on existing structural members (e.g., concrete bearing at pier bracket). The integrity of the existing supported structure is outside of our scope of work.
- A.7 Where voids are created below the slab during lifting, it is recommended to fill with PolyLevel. Tamp to compact soil up to and around footing where soil was excavated to install bracket.

Helical Pier Analysis and Results:

- B.1 All design loads are based on guidance from the applicable building code.
- B.2 Helical piers are designed to support axial compression load only.
- B.3 Maximum, worst-case, total load on a helical pier is **15,200 lbs** (allowable stress combinations).
- B.4 We recommend installation of piers with a 2-7/8" diameter shaft (HP288), 8" and 10" diameter (minimum) helix plates, and a FS288BL2 bracket.
- B.5 Minimum helical pier tip depth is 8 ft below top bracket.
- B.6 An installation torque of **3,400 ft-lbs** should be applied to achieve an allowable capacity greater than the total load.
- B.7 A factor of safety of 2 is used to calculate the allowable soil bearing capacity.
- B.8 Helical pier spacing along the foundation shall not exceed 6'-0" O.C. and 2-ft from a corner (+/- 1ft)
- B.9 Contact engineer if pier is needed below window/door whose sill is less than 24" above footing bottom.
- B.10 Contractor may use up to 6'-0" long spreader beams to improve the footing's spanning capability by carrying load from the footing to the pier (HSS4x4x1/4, ASTM A500 Grade 50).

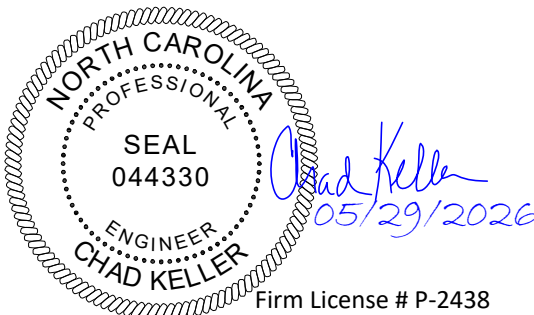

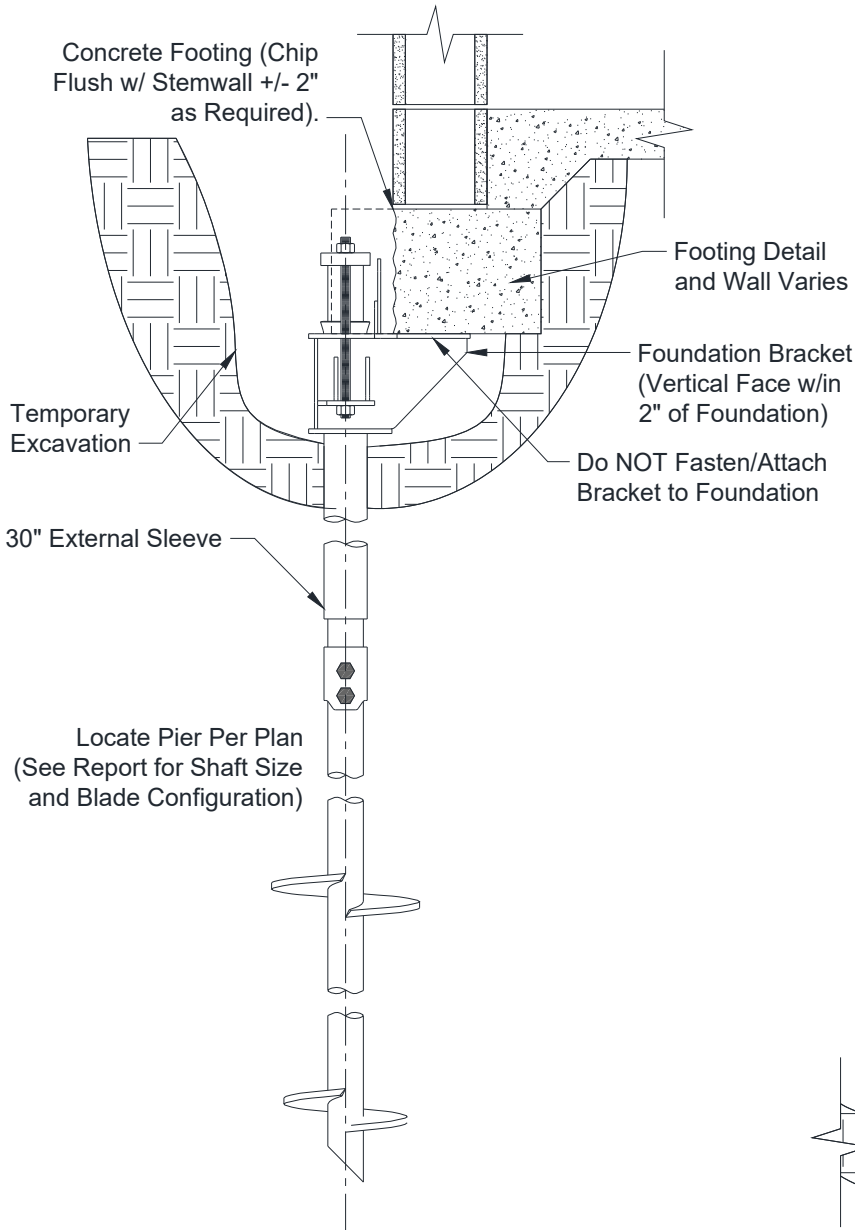

**HELICAL PIER TO FOOTING DETAIL**

**Pier Notes:**

- 1) See manufacturer specs for more information regarding shaft, sleeve, and bracket materials and capacities.
- 2) Where a crack in the foundation is discovered, pier shall be centered on existing crack or add a spreader beam centered on pier nearest the crack with beam extending 6" beyond the crack. Contact engineer if cracking is excessive.
- 3) Contractor to add a spreader beam to improve foundation's spanning capability, as follows: A) See notes on previous page for beam size/shape and max length; B) Place below windows and doors whose sill is less than 24" above the bottom of footing; C) Or place as shown on the Repair Plan.

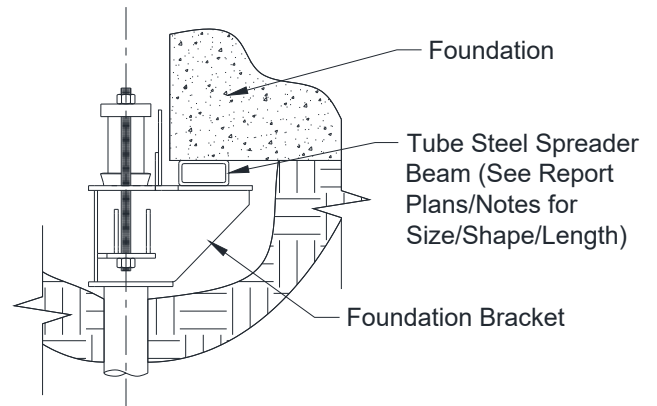

**SPREADER BEAM DETAIL**

FDN Engineering, PLLC  
 2412 N 179th St.  
 Omaha, NE 68116  
 (402) 739-9642

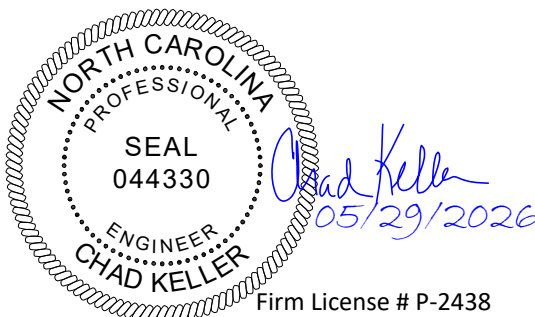

Firm License # P-2438

**LEGEND:**

Ⓝ Indicates Helical Pier and Mark Number

**Helical Pier Notes:**

1. Commercial construction, one-story.
2. Layout of (4) piers, Model HP288 for fndn support - 8'-0" min depth.
3. Installation torque of **3,400 ft-lbs.**
4. Pier max spacing is 6'-0", UNO. Start 2' from corners.
5. Spacing for individual pier may be adjusted +/- 1ft due to site conditions.
6. Notify engineer of discrepancies between plans and site before proceeding.

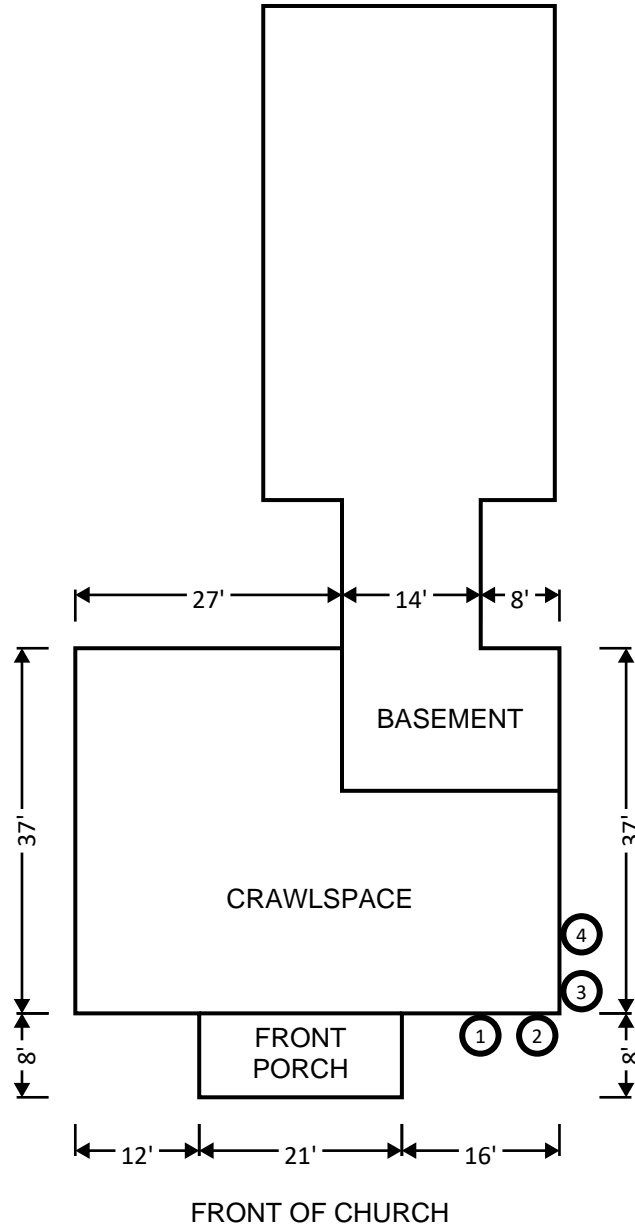

FRONT OF CHURCH

**REPAIR PLAN**

DRAWING NOT TO SCALE

**Project:**

McDonald Property  
530 Peach Farm Rd  
Lillington, NC 27546

**FDN Engineering, PLLC**

2412 N 179th St.  
Omaha, NE 68116  
(402) 739-9642



*Chad Keller*  
05/29/2026

Firm License # P-2438