

Trenco
818 Soundside Rd
Edenton, NC 27932

Re: 26-1922-A
MDP-LOT #16 ROOF

The truss drawing(s) referenced below have been prepared by Truss Engineering Co. under my direct supervision based on the parameters provided by Riverside Roof Truss.

Pages or sheets covered by this seal: I81045301 thru I81045341

My license renewal date for the state of North Carolina is December 31, 2026.

North Carolina COA: C-0844



April 10, 2026

Nathan Fox

IMPORTANT NOTE: The seal on these truss component designs is a certification that the engineer named is licensed in the jurisdiction(s) identified and that the designs comply with ANSI/TPI 1. These designs are based upon parameters shown (e.g., loads, supports, dimensions, shapes and design codes), which were given to MiTek or TRENCO. Any project specific information included is for MiTek's or TRENCO's customers file reference purpose only, and was not taken into account in the preparation of these designs. MiTek or TRENCO has not independently verified the applicability of the design parameters or the designs for any particular building. Before use, the building designer should verify applicability of design parameters and properly incorporate these designs into the overall building design per ANSI/TPI 1, Chapter 2.

Job 26-1922-A	Truss CJ01	Truss Type Diagonal Hip Girder	Qty 2	Ply 1	MDP-LOT #16 ROOF Job Reference (optional)	181045301
------------------	---------------	-----------------------------------	----------	----------	--	-----------

Riverside Roof Truss, LLC,

Danville, Va - 24541,

8.830 s Mar 11 2026 MiTek Industries, Inc. Fri Apr 10 06:38:33 2026 Page 1

ID:kk2_eRZGXXvKblGikzSpyNzs9fO-ubuMpjYWE4uMOUPVIWO7waDb2lZgYXQuq7Q5WLzSCB4



Scale = 1:18.5

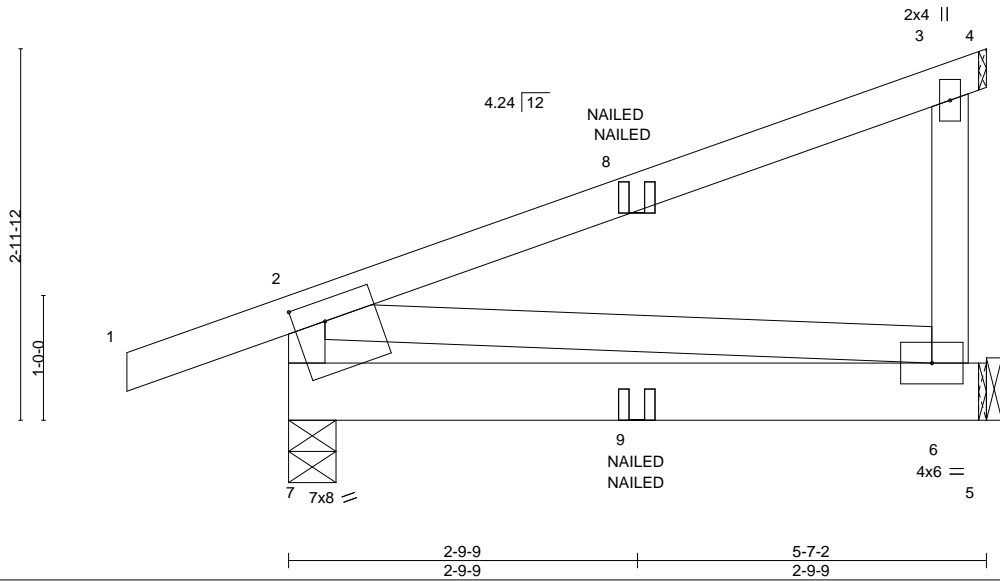

Plate Offsets (X,Y)-- [7:0-3-0,0-2-0]

LOADING (psf)		SPACING-	2-0-0	CSI.	DEFL.	in	(loc)	l/defl	L/d	PLATES	GRIP
TCLL (roof)	20.0	Plate Grip DOL	1.15	TC	Vert(LL)	-0.01	6-7	>999	240	MT20	244/190
Snow (Pf/Pg)	15.4/20.0	Lumber DOL	1.15	BC	Vert(CT)	-0.02	6-7	>999	180		
TCDL	10.0	Rep Stress Incr	NO	WB	Horz(CT)	-0.00	6	n/a	n/a		
BCLL	0.0 *	Code IRC2018/TPI2014		Matrix-MP							
BCDL	10.0									Weight: 35 lb	FT = 20%

LUMBER-
TOP CHORD 2x4 SP No.2
BOT CHORD 2x6 SP No.2
WEBS 2x4 SP No.3

BRACING-
TOP CHORD Structural wood sheathing directly applied or 5-7-2 oc purlins, except end verticals.
BOT CHORD Rigid ceiling directly applied or 10-0-0 oc bracing.

REACTIONS. (size) 7=0-4-9, 6=Mechanical
Max Horz 7=92(LC 12)
Max Uplift 7=-68(LC 12), 6=-51(LC 12)
Max Grav 7=328(LC 17), 6=264(LC 17)

FORCES. (lb) - Max. Comp./Max. Ten. - All forces 250 (lb) or less except when shown.
TOP CHORD 2-7=-277/75

- NOTES-**
- Unbalanced roof live loads have been considered for this design.
 - Wind: ASCE 7-16; Vult=130mph (3-second gust) Vasd=103mph; TCDL=6.0psf; BCDL=6.0psf; h=25ft; B=45ft; L=24ft; eave=4ft; Cat. II; Exp B; Enclosed; MWFRS (directional); cantilever left and right exposed ; end vertical left and right exposed; Lumber DOL=1.60 plate grip DOL=1.60
 - TCLL: ASCE 7-16; Pr=20.0 psf (roof LL: Lum DOL=1.15 Plate DOL=1.15); Pg=20.0 psf; Pf=15.4 psf (Lum DOL = 1.15 Plate DOL = 1.15); Is=1.0; Rough Cat B; Partially Exp.; Ce=1.0; Cs=1.00; Ct=1.10
 - Unbalanced snow loads have been considered for this design.
 - This truss has been designed for greater of min roof live load of 12.0 psf or 1.00 times flat roof load of 15.4 psf on overhangs non-concurrent with other live loads.
 - This truss has been designed for a 10.0 psf bottom chord live load nonconcurrent with any other live loads.
 - * This truss has been designed for a live load of 20.0psf on the bottom chord in all areas where a rectangle 3-6-0 tall by 2-0-0 wide will fit between the bottom chord and any other members.
 - Refer to girder(s) for truss to truss connections.
 - Provide mechanical connection (by others) of truss to bearing plate capable of withstanding 68 lb uplift at joint 7 and 51 lb uplift at joint 6.
 - This truss is designed in accordance with the 2018 International Residential Code sections R502.11.1 and R802.10.2 and referenced standard ANSI/TPI 1.
 - "NAILED" indicates 3-10d (0.148"x3") or 2-12d (0.148"x3.25") toe-nails per NDS guidelines.
 - In the LOAD CASE(S) section, loads applied to the face of the truss are noted as front (F) or back (B).

LOAD CASE(S) Standard
1) Dead + Snow (balanced): Lumber Increase=1.15, Plate Increase=1.15
Uniform Loads (plf)
Vert: 1-2=-51, 2-4=-51, 5-7=-20

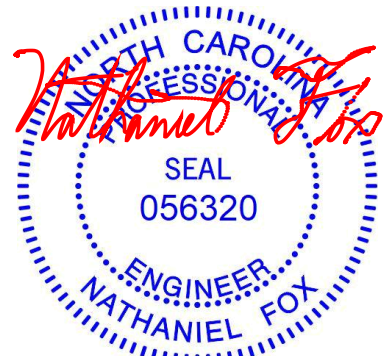

April 10, 2026

WARNING - Verify design parameters and READ NOTES ON THIS AND INCLUDED MITEK REFERENCE PAGE MII-7473 rev. 1/2/2023 BEFORE USE.
Design valid for use only with MiTek® connectors. This design is based only upon parameters shown, and is for an individual building component, not a truss system. Before use, the building designer must verify the applicability of design parameters and properly incorporate this design into the overall building design. Bracing indicated is to prevent buckling of individual truss web and/or chord members only. Additional temporary and permanent bracing is always required for stability and to prevent collapse with possible personal injury and property damage. For general guidance regarding the fabrication, storage, delivery, erection and bracing of trusses and truss systems, see **ANSI/TPI1 Quality Criteria and DSB-22** available from Truss Plate Institute (www.tpinst.org) and **BCSI Building Component Safety Information** available from the Structural Building Component Association (www.sbcacomponents.com)



818 Soundside Road
Edenton, NC 27932

Job 26-1922-A	Truss HG01	Truss Type Hip Girder	Qty 1	Ply 2	MDP-LOT #16 ROOF	81045302
------------------	---------------	--------------------------	----------	----------	------------------	----------

Riverside Roof Truss, LLC, Danville, Va - 24541,

8.830 s Mar 11 2026 MiTek Industries, Inc. Fri Apr 10 06:38:34 2026 Page 1

ID:kk2_eRZGXXvKblGikzSpyNzs9fO-MnSl13Z8?00D0e_iJEwMTnmt8it0Hx113nAe2nzSCB3

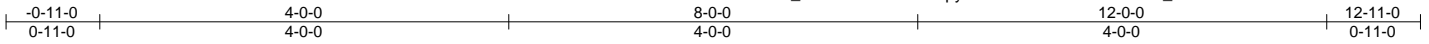

Scale = 1:22.5

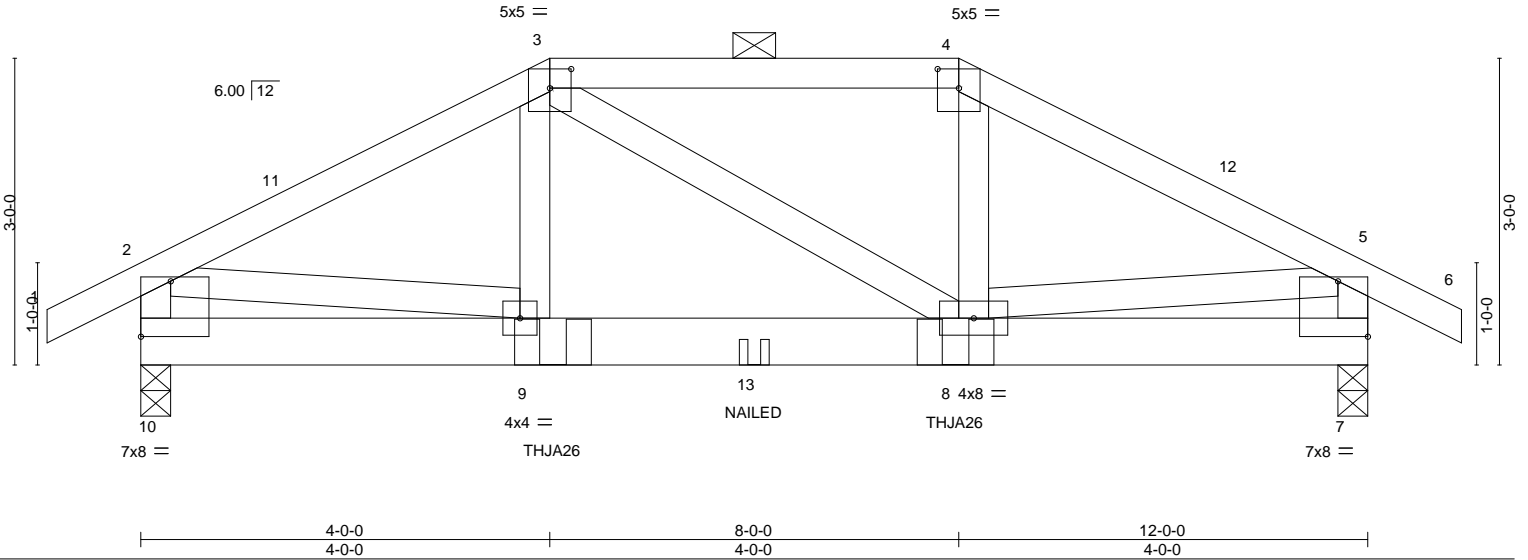

Plate Offsets (X, Y)-- [3:0-2-8,0-2-4], [4:0-2-8,0-2-4], [7:Edge,0-6-8], [10:Edge,0-6-8]

LOADING (psf)	SPACING-	CSL	DEFL.	PLATES	GRIP
TCLL (roof) 20.0	2-0-0	TC 0.20	in (loc) l/defl L/d	MT20	244/190
Snow (Pf/Pg) 20.4/20.0	Plate Grip DOL 1.15	BC 0.21	Vert(LL) -0.02 8-9 >999 240		
TCDL 10.0	Lumber DOL 1.15	WB 0.21	Vert(CT) -0.03 8-9 >999 180		
BCLL 0.0 *	Rep Stress Incr NO	Matrix-MS	Horz(CT) 0.00 7 n/a n/a		
BCDL 10.0	Code IRC2018/TPI2014			Weight: 151 lb	FT = 20%

LUMBER-	BRACING-
TOP CHORD 2x4 SP No.2	TOP CHORD Structural wood sheathing directly applied or 6-0-0 oc purlins, except end verticals, and 2-0-0 oc purlins (6-0-0 max.): 3-4.
BOT CHORD 2x6 SP No.2	BOT CHORD Rigid ceiling directly applied or 10-0-0 oc bracing.
WEBS 2x4 SP No.3	

REACTIONS. (size) 10=0-3-8, 7=0-3-8
 Max Horz 10=63(LC 11)
 Max Uplift 10=188(LC 12), 7=185(LC 12)
 Max Grav 10=1073(LC 35), 7=1063(LC 35)

FORCES. (lb) - Max. Comp./Max. Ten. - All forces 250 (lb) or less except when shown.
 TOP CHORD 2-3=-1373/255, 3-4=-1169/242, 4-5=-1367/253, 2-10=-1027/206, 5-7=-1016/203
 BOT CHORD 8-9=-192/1156
 WEBS 3-9=-69/374, 4-8=-77/407, 2-9=-179/1037, 5-8=-178/1026

- NOTES-**
- 2-ply truss to be connected together with 10d (0.131"x3") nails as follows:
 Top chords connected as follows: 2x4 - 1 row at 0-9-0 oc.
 Bottom chords connected as follows: 2x6 - 2 rows staggered at 0-9-0 oc.
 Webs connected as follows: 2x4 - 1 row at 0-9-0 oc.
 - All loads are considered equally applied to all plies, except if noted as front (F) or back (B) face in the LOAD CASE(S) section. Ply to ply connections have been provided to distribute only loads noted as (F) or (B), unless otherwise indicated.
 - Unbalanced roof live loads have been considered for this design.
 - Wind: ASCE 7-16; Vult=130mph (3-second gust) Vasd=103mph; TCDL=6.0psf; BCDL=6.0psf; h=25ft; B=45ft; L=24ft; eave=4ft; Cat. II; Exp B; Enclosed; MWFRS (directional); cantilever left and right exposed; end vertical left and right exposed; Lumber DOL=1.60 plate grip DOL=1.60
 - TCLL: ASCE 7-16; Pr=20.0 psf (roof LL: Lum DOL=1.15 Plate DOL=1.15); Pg=20.0 psf; Pf=20.4 psf (Lum DOL = 1.15 Plate DOL = 1.15); Is=1.0; Rough Cat B; Partially Exp.; Ce=1.0; Cs=1.00; Ct=1.10, Lu=50-0-0 Rain surcharge applied to all exposed surfaces with slopes less than 0.500/12 in accordance with IBC 1608.3.4.
 - Unbalanced snow loads have been considered for this design.
 - This truss has been designed for greater of min roof live load of 12.0 psf or 1.00 times flat roof load of 15.4 psf on overhangs non-concurrent with other live loads.
 - Provide adequate drainage to prevent water ponding.
 - This truss has been designed for a 10.0 psf bottom chord live load nonconcurrent with any other live loads.
 - * This truss has been designed for a live load of 20.0psf on the bottom chord in all areas where a rectangle 3-6-0 tall by 2-0-0 wide will fit between the bottom chord and any other members.
 - Provide mechanical connection (by others) of truss to bearing plate capable of withstanding 188 lb uplift at joint 10 and 185 lb uplift at joint 7.
 - This truss is designed in accordance with the 2018 International Residential Code sections R502.11.1 and R802.10.2 and referenced standard ANSI/TPI 1.
 - Graphical purlin representation does not depict the size or the orientation of the purlin along the top and/or bottom chord.



April 10, 2026

Continued on page 2

WARNING - Verify design parameters and READ NOTES ON THIS AND INCLUDED MITEK REFERENCE PAGE MII-7473 rev. 1/2/2023 BEFORE USE.
 Design valid for use only with MiTek® connectors. This design is based only upon parameters shown, and is for an individual building component, not a truss system. Before use, the building designer must verify the applicability of design parameters and properly incorporate this design into the overall building design. Bracing indicated is to prevent buckling of individual truss web and/or chord members only. Additional temporary and permanent bracing is always required for stability and to prevent collapse with possible personal injury and property damage. For general guidance regarding the fabrication, storage, delivery, erection and bracing of trusses and truss systems, see **ANSI/TP1 Quality Criteria and DSB-22** available from Truss Plate Institute (www.tpinst.org) and **BCSI Building Component Safety Information** available from the Structural Building Component Association (www.sbcacomponents.com)

ENGINEERING BY
TRENCO
 A MiTek Affiliate

818 Soundside Road
 Edenton, NC 27932

Job 26-1922-A	Truss HG01	Truss Type Hip Girder	Qty 1	Ply 2	MDP-LOT #16 ROOF Job Reference (optional)	I81045302
------------------	---------------	--------------------------	----------	-----------------	--	-----------

Riverside Roof Truss, LLC, Danville, Va - 24541,

8.830 s Mar 11 2026 MiTek Industries, Inc. Fri Apr 10 06:38:35 2026 Page 2
ID:kk2_eRZGXvKbGikzSpyNzs9fO-q_07EPanmi94eoZusXRb0?I2u6DF0OHBHRvBbEzSCB2

NOTES-

- 14) Use Simpson Strong-Tie THJA26 (THJA26 on 2 ply, Right Hand Hip) or equivalent at 4-0-6 from the left end to connect truss(es) to back face of bottom chord.
- 15) Use Simpson Strong-Tie THJA26 (THJA26 on 2 ply, Left Hand Hip) or equivalent at 7-11-10 from the left end to connect truss(es) to back face of bottom chord.
- 16) Fill all nail holes where hanger is in contact with lumber.
- 17) "NAILED" indicates 3-10d (0.148"x3") or 3-12d (0.148"x3.25") toe-nails per NDS guidelines.

LOAD CASE(S) Standard

- 1) Dead + Snow (balanced): Lumber Increase=1.15, Plate Increase=1.15
Uniform Loads (plf)
Vert: 1-2=-51, 2-3=-51, 3-4=-61, 4-5=-51, 5-6=-51, 7-10=-20
Concentrated Loads (lb)
Vert: 9=-387(B) 8=-387(B) 13=-151(B)

WARNING - Verify design parameters and READ NOTES ON THIS AND INCLUDED MITEK REFERENCE PAGE MII-7473 rev. 1/2/2023 BEFORE USE.

Design valid for use only with MiTek® connectors. This design is based only upon parameters shown, and is for an individual building component, not a truss system. Before use, the building designer must verify the applicability of design parameters and properly incorporate this design into the overall building design. Bracing indicated is to prevent buckling of individual truss web and/or chord members only. Additional temporary and permanent bracing is always required for stability and to prevent collapse with possible personal injury and property damage. For general guidance regarding the fabrication, storage, delivery, erection and bracing of trusses and truss systems, see **ANSI/TP1 Quality Criteria and DSB-22** available from Truss Plate Institute (www.tpinst.org) and **BCSI Building Component Safety Information** available from the Structural Building Component Association (www.sbcacomponents.com)



818 Soundside Road
Edenton, NC 27932

Job 26-1922-A	Truss J01	Truss Type Jack-Open	Qty 4	Ply 1	MDP-LOT #16 ROOF	181045303
------------------	--------------	-------------------------	----------	----------	------------------	-----------

Riverside Roof Truss, LLC, Danville, Va - 24541,

8.830 s Mar 11 2026 MiTek Industries, Inc. Fri Apr 10 06:38:35 2026 Page 1

ID:kk2_eRZGXXvKblGikzSpyNzs9fO-q_07EPanmi94eoZusxRb0?I4c6Gz0R5BHRvBbEzSCB2

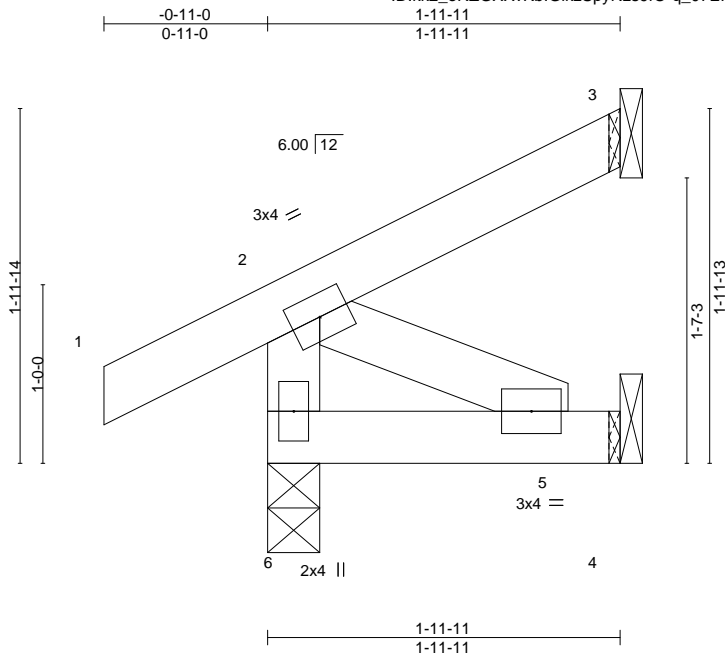

Scale = 1:12.9

LOADING (psf)	SPACING-	CSI.	DEFL.	PLATES	GRIP
TCLL (roof) 20.0	2-0-0	TC 0.09	in (loc) l/defl L/d	MT20	244/190
Snow (Pf/Pg) 15.4/20.0	Plate Grip DOL 1.15	BC 0.03	Vert(LL) -0.00 6 >999 240		
TCDL 10.0	Lumber DOL 1.15	WB 0.03	Vert(CT) -0.00 5 >999 180		
BCLL 0.0 *	Rep Stress Incr YES	Matrix-MP	Horz(CT) -0.00 3 n/a n/a		
BCDL 10.0	Code IRC2018/TPI2014			Weight: 11 lb	FT = 20%

LUMBER-
TOP CHORD 2x4 SP No.2
BOT CHORD 2x4 SP No.2
WEBS 2x4 SP No.3

BRACING-
TOP CHORD Structural wood sheathing directly applied or 1-11-11 oc purlins, except end verticals.
BOT CHORD Rigid ceiling directly applied or 10-0-0 oc bracing.

REACTIONS. (size) 6=0-3-8, 3=Mechanical, 4=Mechanical
Max Horz 6=67(LC 16)
Max Uplift 6=20(LC 16), 3=-10(LC 13), 4=-14(LC 16)
Max Grav 6=184(LC 21), 3=43(LC 21), 4=36(LC 7)

FORCES. (lb) - Max. Comp./Max. Ten. - All forces 250 (lb) or less except when shown.

NOTES-

- Unbalanced roof live loads have been considered for this design.
- Wind: ASCE 7-16; Vult=130mph (3-second gust) Vasd=103mph; TCCL=6.0psf; BCDL=6.0psf; h=25ft; B=45ft; L=24ft; eave=4ft; Cat. II; Exp B; Enclosed; MWFRS (directional) and C-C Exterior(2E) zone; cantilever left and right exposed; end vertical left and right exposed; C-C for members and forces & MWFRS for reactions shown; Lumber DOL=1.60 plate grip DOL=1.60
- TCLL: ASCE 7-16; Pr=20.0 psf (roof LL: Lum DOL=1.15 Plate DOL=1.15); Pg=20.0 psf; Pf=15.4 psf (Lum DOL = 1.15 Plate DOL = 1.15); Is=1.0; Rough Cat B; Partially Exp.; Ce=1.0; Cs=1.00; Ct=1.10
- Unbalanced snow loads have been considered for this design.
- This truss has been designed for greater of min roof live load of 12.0 psf or 1.00 times flat roof load of 15.4 psf on overhangs non-concurrent with other live loads.
- This truss has been designed for a 10.0 psf bottom chord live load nonconcurrent with any other live loads.
- * This truss has been designed for a live load of 20.0psf on the bottom chord in all areas where a rectangle 3-6-0 tall by 2-0-0 wide will fit between the bottom chord and any other members.
- Refer to girder(s) for truss to truss connections.
- Provide mechanical connection (by others) of truss to bearing plate capable of withstanding 20 lb uplift at joint 6, 10 lb uplift at joint 3 and 14 lb uplift at joint 4.
- This truss is designed in accordance with the 2018 International Residential Code sections R502.11.1 and R802.10.2 and referenced standard ANSI/TPI 1.



April 10, 2026

WARNING - Verify design parameters and READ NOTES ON THIS AND INCLUDED MITEK REFERENCE PAGE MII-7473 rev. 1/2/2023 BEFORE USE.

Design valid for use only with MiTek® connectors. This design is based only upon parameters shown, and is for an individual building component, not a truss system. Before use, the building designer must verify the applicability of design parameters and properly incorporate this design into the overall building design. Bracing indicated is to prevent buckling of individual truss web and/or chord members only. Additional temporary and permanent bracing is always required for stability and to prevent collapse with possible personal injury and property damage. For general guidance regarding the fabrication, storage, delivery, erection and bracing of trusses and truss systems, see **ANSI/TPI Quality Criteria and DSB-22** available from Truss Plate Institute (www.tpinst.org) and **BCSI Building Component Safety Information** available from the Structural Building Component Association (www.sbcacomponents.com)



818 Soundside Road
Edenton, NC 27932

Job 26-1922-A	Truss M01	Truss Type Monopitch	Qty 7	Ply 1	MDP-LOT #16 ROOF	81045304
------------------	--------------	-------------------------	----------	----------	------------------	----------

Riverside Roof Truss, LLC, Danville, Va - 24541,

8.830 s Mar 11 2026 MiTek Industries, Inc. Fri Apr 10 06:38:36 2026 Page 1

ID:kk2_eRZGXxvKbI GikzSpyNzs9fO-IAaVSlAPX?HxFy84QeyqYCr4mWQ9IhIKW5f17gzSCB1

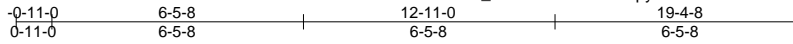

Scale = 1:59.2

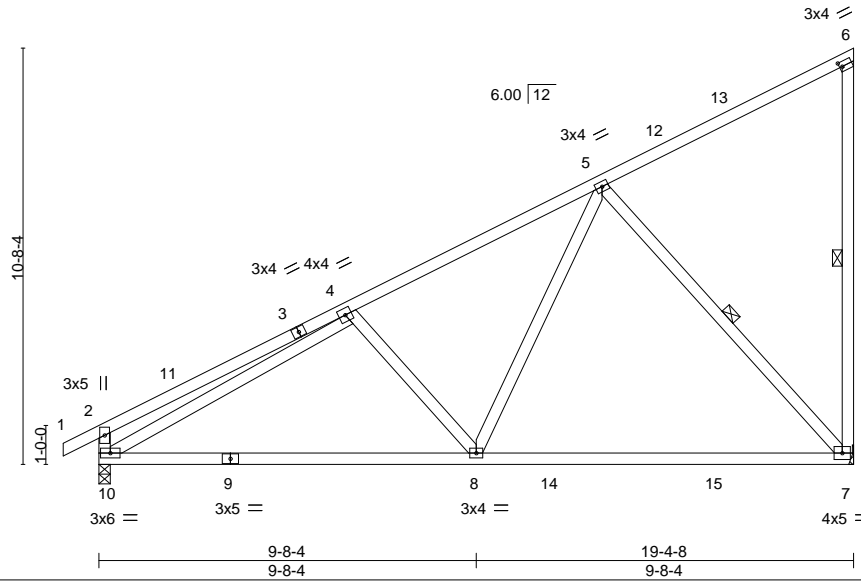

Plate Offsets (X,Y)-- [6:0-0-13,0-1-8]

LOADING (psf)		SPACING-	2-0-0	CSI.		DEFL.	in (loc)	l/defl	L/d	PLATES	GRIP	
TCLL (roof)	20.0	Plate Grip DOL	1.15	TC	0.77	Vert(LL)	-0.34	7-8	>680	240	MT20	244/190
Snow (Pf/Pg)	15.4/20.0	Lumber DOL	1.15	BC	0.80	Vert(CT)	-0.52	7-8	>444	180		
TCDL	10.0	Rep Stress Incr	YES	WB	0.84	Horz(CT)	0.02	7	n/a	n/a		
BCLL	0.0 *	Code IRC2018/TPI2014		Matrix-MS								
BCDL	10.0											
												Weight: 121 lb FT = 20%

LUMBER-		BRACING-	
TOP CHORD	2x4 SP No.2	TOP CHORD	Structural wood sheathing directly applied or 5-7-7 oc purlins, except end verticals.
BOT CHORD	2x4 SP No.2 *Except* 7-9: 2x4 SP No.1	BOT CHORD	Rigid ceiling directly applied or 8-11-14 oc bracing.
WEBS	2x4 SP No.3 *Except* 6-7: 2x4 SP No.2	WEBS	1 Row at midpt 6-7, 5-7

REACTIONS. (size) 7=Mechanical, 10=0-3-8
 Max Horz 10=366(LC 15)
 Max Uplift 7=63(LC 16), 10=63(LC 16)
 Max Grav 7=933(LC 28), 10=905(LC 28)

FORCES. (lb) - Max. Comp./Max. Ten. - All forces 250 (lb) or less except when shown.
 TOP CHORD 2-4=-457/144, 4-5=-1006/195, 2-10=-398/171
 BOT CHORD 8-10=-414/1036, 7-8=-271/586
 WEBS 4-8=-282/210, 5-8=-33/686, 5-7=-823/244, 4-10=-817/91

- NOTES-**
- 1) Unbalanced roof live loads have been considered for this design.
 - 2) Wind: ASCE 7-16; Vult=130mph (3-second gust) Vasd=103mph; TCDL=6.0psf; BCDL=6.0psf; h=25ft; B=45ft; L=24ft; eave=4ft; Cat. II; Exp B; Enclosed; MWFRS (directional) and C-C Exterior(2E) -0-11-0 to 2-1-0, Interior(1) 2-1-0 to 19-2-12 zone; cantilever left and right exposed; end vertical left and right exposed; C-C for members and forces & MWFRS for reactions shown; Lumber DOL=1.60 plate grip DOL=1.60
 - 3) TCLL: ASCE 7-16; Pr=20.0 psf (roof LL: Lum DOL=1.15 Plate DOL=1.15); Pg=20.0 psf; Pf=15.4 psf (Lum DOL = 1.15 Plate DOL = 1.15); Is=1.0; Rough Cat B; Partially Exp.; Ce=1.0; Cs=1.00; Ct=1.10
 - 4) Unbalanced snow loads have been considered for this design.
 - 5) This truss has been designed for greater of min roof live load of 12.0 psf or 1.00 times flat roof load of 15.4 psf on overhangs non-concurrent with other live loads.
 - 6) This truss has been designed for a 10.0 psf bottom chord live load nonconcurrent with any other live loads.
 - 7) * This truss has been designed for a live load of 20.0psf on the bottom chord in all areas where a rectangle 3-6-0 tall by 2-0-0 wide will fit between the bottom chord and any other members, with BCDL = 10.0psf.
 - 8) Refer to girder(s) for truss to truss connections.
 - 9) Provide mechanical connection (by others) of truss to bearing plate capable of withstanding 63 lb uplift at joint 7 and 63 lb uplift at joint 10.
 - 10) This truss is designed in accordance with the 2018 International Residential Code sections R502.11.1 and R802.10.2 and referenced standard ANSI/TPI 1.



April 10, 2026

WARNING - Verify design parameters and READ NOTES ON THIS AND INCLUDED MITEK REFERENCE PAGE MII-7473 rev. 1/2/2023 BEFORE USE.
 Design valid for use only with MiTek® connectors. This design is based only upon parameters shown, and is for an individual building component, not a truss system. Before use, the building designer must verify the applicability of design parameters and properly incorporate this design into the overall building design. Bracing indicated is to prevent buckling of individual truss web and/or chord members only. Additional temporary and permanent bracing is always required for stability and to prevent collapse with possible personal injury and property damage. For general guidance regarding the fabrication, storage, delivery, erection and bracing of trusses and truss systems, see **ANSI/TPI Quality Criteria and DSB-22** available from Truss Plate Institute (www.tpinst.org) and **BCSI Building Component Safety Information** available from the Structural Building Component Association (www.sbcacomponents.com)



Job 26-1922-A	Truss M01AS	Truss Type Monopitch	Qty 3	Ply 1	MDP-LOT #16 ROOF	181045306
------------------	----------------	-------------------------	----------	----------	------------------	-----------

Riverside Roof Truss, LLC, Danville, Va - 24541,

8.830 s Mar 11 2026 MiTek Industries, Inc. Fri Apr 10 06:38:37 2026 Page 1

ID:kk2_eRZGXXvKbGikzSpyNzs9fO-mM8tf5b11JPot5jG_MT35QOEswjVUCPTIIOf6zSCB0

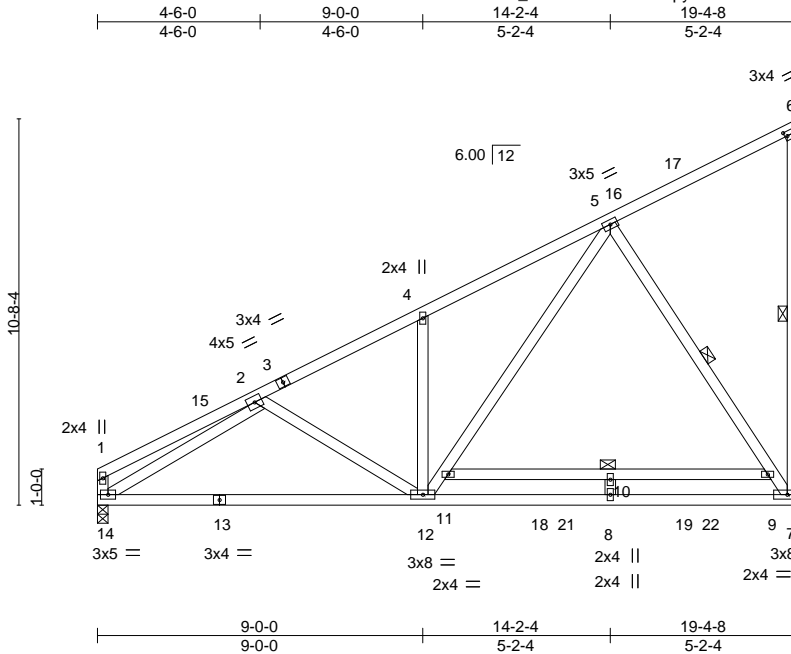

Scale: 3/16"=1'

Plate Offsets (X,Y)-- [6:0-0-13,0-1-8]

LOADING (psf)	SPACING-	CSI.	DEFL.	PLATES	GRIP
TCLL (roof) 20.0	2-0-0	TC 0.77	in (loc) l/defl L/d	MT20	244/190
Snow (Pf/Pg) 15.4/20.0	Plate Grip DOL 1.15	BC 0.99	Vert(LL) -0.53 7-8 >431 240		
TCDL 10.0	Lumber DOL 1.15	WB 0.62	Vert(CT) -0.85 7-8 >269 180		
BCLL 0.0 *	Rep Stress Incr YES	Matrix-MS	Horz(CT) 0.02 7 n/a n/a		
BCDL 10.0	Code IRC2018/TPI2014			Weight: 140 lb	FT = 20%

LUMBER-

TOP CHORD	2x4 SP No.2
BOT CHORD	2x4 SP No.1 *Except* 13-14: 2x4 SP No.2
WEBS	2x4 SP No.3 *Except* 6-7: 2x4 SP No.2

BRACING-

TOP CHORD	Structural wood sheathing directly applied or 5-1-8 oc purlins, except end verticals.
BOT CHORD	Rigid ceiling directly applied or 2-2-0 oc bracing. Except:
WEBS	5-5-0 oc bracing: 9-11 1 Row at midpt 6-7, 5-7

REACTIONS. (size) 7=Mechanical, 14=0-3-8
Max Horz 14=358(LC 15)
Max Grav 7=1213(LC 27), 14=948(LC 27)

FORCES. (lb) - Max. Comp./Max. Ten. - All forces 250 (lb) or less except when shown.
TOP CHORD 1-2=-254/52, 2-4=-1274/109, 4-5=-1261/210
BOT CHORD 12-14=-416/1213, 8-12=-191/613, 7-8=-191/613
WEBS 4-12=-285/164, 11-12=-120/931, 5-11=-77/1126, 5-9=-858/223, 7-9=-1050/156,
2-14=-1167/117

- NOTES-**
- Unbalanced roof live loads have been considered for this design.
 - Wind: ASCE 7-16; Vult=130mph (3-second gust) Vasd=103mph; TCCL=6.0psf; BCDL=6.0psf; h=25ft; B=45ft; L=24ft; eave=4ft; Cat. II; Exp B; Enclosed; MWFRS (directional) and C-C Exterior(2E) 0-1-12 to 3-1-12, Interior(1) 3-1-12 to 19-2-12 zone; cantilever left and right exposed ; end vertical left and right exposed; C-C for members and forces & MWFRS for reactions shown; Lumber DOL=1.60 plate grip DOL=1.60
 - TCLL: ASCE 7-16; Pr=20.0 psf (roof LL: Lum DOL=1.15 Plate DOL=1.15); Pg=20.0 psf; Pf=15.4 psf (Lum DOL = 1.15 Plate DOL = 1.15); Is=1.0; Rough Cat B; Partially Exp.; Ce=1.0; Cs=1.00; Ct=1.10
 - Unbalanced snow loads have been considered for this design.
 - This truss has been designed for a 10.0 psf bottom chord live load nonconcurrent with any other live loads.
 - * This truss has been designed for a live load of 20.0psf on the bottom chord in all areas where a rectangle 3-6-0 tall by 2-0-0 wide will fit between the bottom chord and any other members, with BCDL = 10.0psf.
 - Refer to girder(s) for truss to truss connections.
 - This truss is designed in accordance with the 2018 International Residential Code sections R502.11.1 and R802.10.2 and referenced standard ANSI/TPI 1.



April 10, 2026

WARNING - Verify design parameters and READ NOTES ON THIS AND INCLUDED MITEK REFERENCE PAGE MII-7473 rev. 1/2/2023 BEFORE USE.
Design valid for use only with MiTek® connectors. This design is based only upon parameters shown, and is for an individual building component, not a truss system. Before use, the building designer must verify the applicability of design parameters and properly incorporate this design into the overall building design. Bracing indicated is to prevent buckling of individual truss web and/or chord members only. Additional temporary and permanent bracing is always required for stability and to prevent collapse with possible personal injury and property damage. For general guidance regarding the fabrication, storage, delivery, erection and bracing of trusses and truss systems, see **ANSI/TPH Quality Criteria and DSB-22** available from Truss Plate Institute (www.tpinst.org) and **BCSI Building Component Safety Information** available from the Structural Building Component Association (www.sbcacomponents.com)



818 Soundside Road
Edenton, NC 27932

Job 26-1922-A	Truss M01G	Truss Type Monopitch	Qty 2	Ply 1	MDP-LOT #16 ROOF	181045307
------------------	---------------	-------------------------	----------	----------	------------------	-----------

Riverside Roof Truss, LLC, Danville, Va - 24541,

8.830 s Mar 11 2026 MiTek Industries, Inc. Fri Apr 10 06:38:37 2026 Page 1
 ID:kk2_eRZGXXvKblGikzSpyNzs9fO-mM8f5b11JPot5jG_MT35QODhwoPUAFTIIOIf6zSCB0

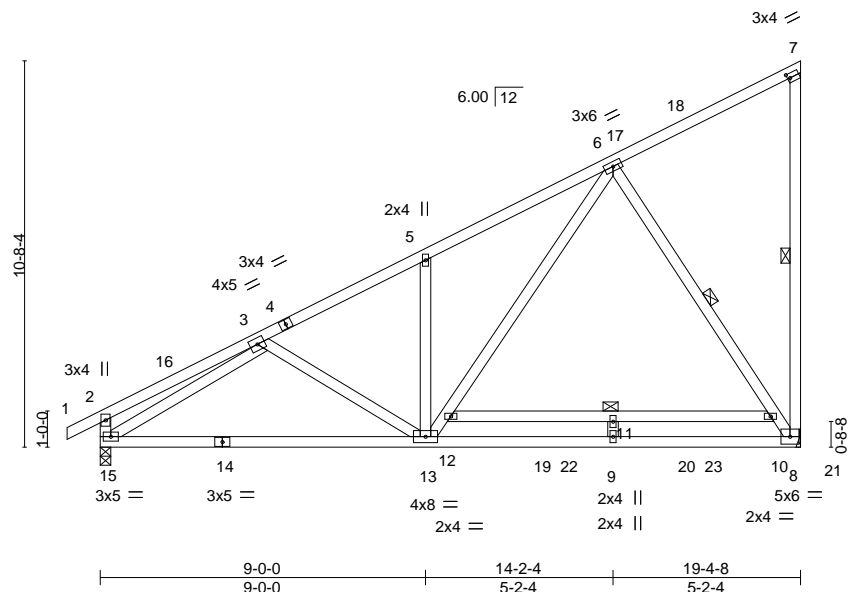

Scale: 3/16"=1'

Plate Offsets (X,Y)--	[7:0-0-13,0-1-8]
-----------------------	------------------

LOADING (psf)	SPACING-	CSI.	DEFL.	PLATES	GRIP
TCLL (roof) 20.0	2-4-0	TC 0.89	in (loc) l/defl L/d	MT20	244/190
Snow (Pf/Pg) 15.4/20.0	Plate Grip DOL 1.15	BC 0.68	Vert(LL) -0.53 8-9 >433 240		
TCDL 10.0	Lumber DOL 1.15	WB 0.73	Vert(CT) -0.85 8-9 >269 180		
BCLL 0.0 *	Rep Stress Incr NO	Matrix-MS	Horz(CT) 0.02 8 n/a n/a		
BCDL 10.0	Code IRC2018/TPI2014			Weight: 142 lb	FT = 20%

LUMBER-	BRACING-
TOP CHORD 2x4 SP No.2	TOP CHORD Structural wood sheathing directly applied or 4-8-4 oc purlins, except end verticals.
BOT CHORD 2x4 SP DSS *Except* 14-15: 2x4 SP No.2	BOT CHORD Rigid ceiling directly applied or 8-4-5 oc bracing. Except:
WEBS 2x4 SP No.3 *Except* 7-8: 2x4 SP No.2	WEBS 6-0-0 oc bracing: 10-12 1 Row at midpt 7-8, 6-8

REACTIONS. (size) 8=Mechanical, 15=0-3-8
 Max Horz 15=427(LC 13)
 Max Uplift 15=39(LC 16)
 Max Grav 8=1414(LC 28), 15=1172(LC 28)

FORCES. (lb) - Max. Comp./Max. Ten. - All forces 250 (lb) or less except when shown.
 TOP CHORD 2-3=-328/80, 3-5=-1483/123, 5-6=-1470/242, 2-15=-329/151
 BOT CHORD 13-15=-483/1403, 9-13=-223/716, 8-9=-223/716
 WEBS 5-13=-337/194, 12-13=-137/1083, 6-12=-88/1313, 6-10=-1000/259, 8-10=-1227/180,
 3-15=-1327/105

- NOTES-**
- Unbalanced roof live loads have been considered for this design.
 - Wind: ASCE 7-16; Vult=130mph (3-second gust) Vasd=103mph; TCDL=6.0psf; BCDL=6.0psf; h=25ft; B=45ft; L=24ft; eave=4ft; Cat. II; Exp B; Enclosed; MWFRS (directional) and C-C Exterior(2E) -0-11-0 to 2-1-0, Interior(1) 2-1-0 to 19-2-12 zone; cantilever left and right exposed ; end vertical left and right exposed;C-C for members and forces & MWFRS for reactions shown; Lumber DOL=1.60 plate grip DOL=1.60
 - TCLL: ASCE 7-16; Pr=20.0 psf (roof LL: Lum DOL=1.15 Plate DOL=1.15); Pg=20.0 psf; Pf=15.4 psf (Lum DOL = 1.15 Plate DOL = 1.15); Is=1.0; Rough Cat B; Partially Exp.; Ce=1.0; Cs=1.00; Ct=1.10
 - Unbalanced snow loads have been considered for this design.
 - This truss has been designed for greater of min roof live load of 12.0 psf or 1.00 times flat roof load of 15.4 psf on overhangs non-concurrent with other live loads.
 - This truss has been designed for a 10.0 psf bottom chord live load nonconcurrent with any other live loads.
 - * This truss has been designed for a live load of 20.0psf on the bottom chord in all areas where a rectangle 3-6-0 tall by 2-0-0 wide will fit between the bottom chord and any other members, with BCDL = 10.0psf.
 - Refer to girder(s) for truss to truss connections.
 - Provide mechanical connection (by others) of truss to bearing plate capable of withstanding 39 lb uplift at joint 15.
 - This truss is designed in accordance with the 2018 International Residential Code sections R502.11.1 and R802.10.2 and referenced standard ANSI/TPI 1.



April 10, 2026

<p>WARNING - Verify design parameters and READ NOTES ON THIS AND INCLUDED MITEK REFERENCE PAGE MII-7473 rev. 1/2/2023 BEFORE USE.</p> <p>Design valid for use only with MiTek® connectors. This design is based only upon parameters shown, and is for an individual building component, not a truss system. Before use, the building designer must verify the applicability of design parameters and properly incorporate this design into the overall building design. Bracing indicated is to prevent buckling of individual truss web and/or chord members only. Additional temporary and permanent bracing is always required for stability and to prevent collapse with possible personal injury and property damage. For general guidance regarding the fabrication, storage, delivery, erection and bracing of trusses and truss systems, see ANSI/TP1 Quality Criteria and DSB-22 available from Truss Plate Institute (www.tpinst.org) and BCSI Building Component Safety Information available from the Structural Building Component Association (www.sbcacomponents.com)</p>	<p>ENGINEERING BY</p>  <p>A MITEK Affiliate</p> <p>818 Soundside Road Edenton, NC 27932</p>
--	--

Job 26-1922-A	Truss M01GE	Truss Type GABLE	Qty 2	Ply 1	MDP-LOT #16 ROOF Job Reference (optional)	181045308
------------------	----------------	---------------------	----------	----------	--	-----------

Riverside Roof Truss, LLC, Danville, Va - 24541,

8.830 s Mar 11 2026 MiTek Industries, Inc. Fri Apr 10 06:38:38 2026 Page 1

ID:kk2_eRZGXvKblGikzSpyNzs9fO-EZiFsRcf3dXfVfITY3_IddwPbJCBdMxd_P8sBYzSCB?

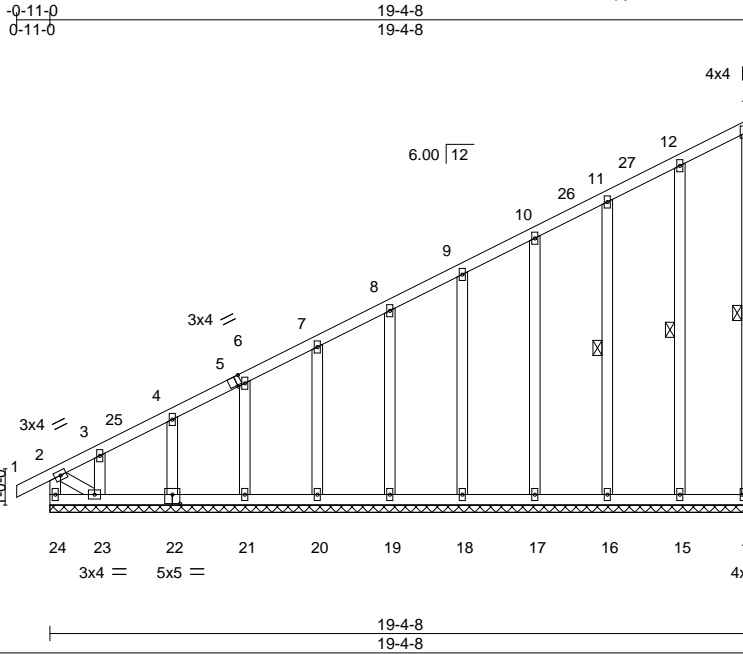

Scale: 3/16"=1'

Plate Offsets (X,Y)--	[5:0-1-9,Edge], [14:Edge,0-3-8], [22:0-2-8,0-3-0]				
LOADING (psf)	SPACING-	CSI.	DEFL.	PLATES	GRIP
TCLL (roof) 20.0	2-0-0	TC 0.81	in (loc) l/defl L/d	MT20	244/190
Snow (Pf/Pg) 15.4/20.0	Plate Grip DOL 1.15	BC 0.38	Vert(LL) -0.00 1 n/r 120		
TCDL 10.0	Lumber DOL 1.15	WB 0.18	Vert(CT) -0.00 1 n/r 120		
BCLL 0.0 *	Rep Stress Incr YES	Matrix-S	Horz(CT) -0.00 14 n/a n/a		
BCDL 10.0	Code IRC2018/TPI2014			Weight: 149 lb	FT = 20%

LUMBER-	BRACING-
TOP CHORD 2x4 SP No.2	TOP CHORD Structural wood sheathing directly applied or 6-0-0 oc purlins, except end verticals.
BOT CHORD 2x4 SP No.2	BOT CHORD Rigid ceiling directly applied or 10-0-0 oc bracing, Except: 6-0-0 oc bracing: 23-24.
WEBS 2x4 SP No.3 *Except*	WEBS 1 Row at midpt 13-14, 12-15, 11-16
OTHERS 13-14: 2x4 SP No.2	
OTHERS 2x4 SP No.3	

REACTIONS. All bearings 19-4-8.
 (lb) - Max Horz 24=366(LC 15)
 Max Uplift All uplift 100 lb or less at joint(s) 24, 14, 15, 16, 17, 18, 19, 20, 21, 22 except 23=179(LC 13)
 Max Grav All reactions 250 lb or less at joint(s) 14, 15, 16, 17, 18, 19, 20, 21, 22, 23 except 24=305(LC 13)

FORCES. (lb) - Max. Comp./Max. Ten. - All forces 250 (lb) or less except when shown.
 TOP CHORD 2-24=552/289, 2-3=599/329, 3-4=558/315, 4-6=509/298, 6-7=461/283, 7-8=413/267, 8-9=365/251, 9-10=317/235, 10-11=269/219
 BOT CHORD 23-24=627/423
 WEBS 2-23=314/609

- NOTES-**
- Unbalanced roof live loads have been considered for this design.
 - Wind: ASCE 7-16; Vult=130mph (3-second gust) Vasd=103mph; TCDL=6.0psf; BCDL=6.0psf; h=25ft; B=45ft; L=24ft; eave=2ft; Cat. II; Exp B; Enclosed; MWFRS (directional) and C-C Corner(3E) -0-11-0 to 2-1-0, Exterior(2N) 2-1-0 to 19-2-12 zone; cantilever left and right exposed; end vertical left and right exposed; C-C for members and forces & MWFRS for reactions shown; Lumber DOL=1.60 plate grip DOL=1.60
 - Truss designed for wind loads in the plane of the truss only. For studs exposed to wind (normal to the face), see Standard Industry Gable End Details as applicable, or consult qualified building designer as per ANSI/TPI 1.
 - TCLL: ASCE 7-16; Pr=20.0 psf (roof LL: Lum DOL=1.15 Plate DOL=1.15); Pg=20.0 psf; Pf=15.4 psf (Lum DOL = 1.15 Plate DOL = 1.15); Is=1.0; Rough Cat B; Partially Exp.; Ce=1.0; Cs=1.00; Ct=1.10
 - Unbalanced snow loads have been considered for this design.
 - This truss has been designed for greater of min roof live load of 12.0 psf or 1.00 times flat roof load of 15.4 psf on overhangs non-concurrent with other live loads.
 - All plates are 2x4 MT20 unless otherwise indicated.
 - Gable requires continuous bottom chord bearing.
 - Truss to be fully sheathed from one face or securely braced against lateral movement (i.e. diagonal web).
 - Gable studs spaced at 2-0-0 oc.
 - This truss has been designed for a 10.0 psf bottom chord live load nonconcurrent with any other live loads.
 - * This truss has been designed for a live load of 20.0psf on the bottom chord in all areas where a rectangle 3-6-0 tall by 2-0-0 wide will fit between the bottom chord and any other members.
 - Provide mechanical connection (by others) of truss to bearing plate capable of withstanding 100 lb uplift at joint(s) 24, 14, 15, 16, 17, 18, 19, 20, 21, 22 except (jt=lb) 23=179.
 - This truss is designed in accordance with the 2018 International Residential Code sections R502.11.1 and R802.10.2 and referenced standard ANSI/TPI 1.



April 10, 2026

Job 26-1922-A	Truss M01S	Truss Type Monopitch	Qty 4	Ply 1	MDP-LOT #16 ROOF	181045309
------------------	---------------	-------------------------	----------	----------	------------------	-----------

Riverside Roof Truss, LLC, Danville, Va - 24541,

8.830 s Mar 11 2026 MiTek Industries, Inc. Fri Apr 10 06:38:39 2026 Page 1

ID:kk2_eRZGXxvKblGikzSpyNzs9fO-ilFe4mdHqwfw7Psf5nVXArTayjPzy6wmC3tPk?zSCB_

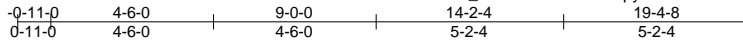

Scale: 3/16"=1'

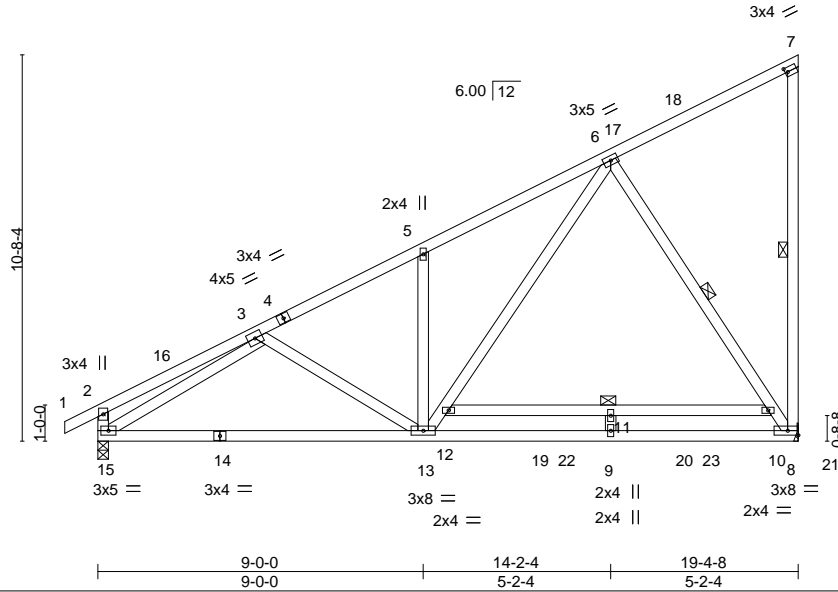

Plate Offsets (X,Y)-- [7:0-0-13,0-1-8]

LOADING (psf)		SPACING-	2-0-0	CSI.		DEFL.	in (loc)	l/defl	L/d	PLATES	GRIP	
TCLL (roof)	20.0	Plate Grip DOL	1.15	TC	0.77	Vert(LL)	-0.53	8-9	>431	240	MT20	244/190
Snow (Pf/Pg)	15.4/20.0	Lumber DOL	1.15	BC	0.99	Vert(CT)	-0.85	8-9	>269	180		
TCDL	10.0	Rep Stress Incr	YES	WB	0.62	Horz(CT)	0.02	8	n/a	n/a		
BCLL	0.0 *	Code IRC2018/TPI2014		Matrix-MS								
BCDL	10.0											
												Weight: 142 lb FT = 20%

LUMBER-		BRACING-	
TOP CHORD	2x4 SP No.2	TOP CHORD	Structural wood sheathing directly applied or 5-1-9 oc purlins, except end verticals.
BOT CHORD	2x4 SP No.1 *Except* 14-15: 2x4 SP No.2	BOT CHORD	Rigid ceiling directly applied or 2-2-0 oc bracing. Except:
WEBS	2x4 SP No.3 *Except* 7-8: 2x4 SP No.2	WEBS	5-5-0 oc bracing: 10-12 1 Row at midpt 7-8, 6-8

REACTIONS. (size) 8=Mechanical, 15=0-3-8
 Max Horz 15=366(LC 13)
 Max Uplift 15=34(LC 16)
 Max Grav 8=1212(LC 28), 15=1004(LC 28)

FORCES. (lb) - Max. Comp./Max. Ten. - All forces 250 (lb) or less except when shown.
 TOP CHORD 2-3=-283/68, 3-5=-1271/106, 5-6=-1259/208, 2-15=-283/128
 BOT CHORD 13-15=-414/1202, 9-13=-191/612, 8-9=-191/612
 WEBS 5-13=-289/166, 12-13=-118/929, 6-12=-75/1124, 6-10=-856/223, 8-10=-1048/156,
 3-15=-1135/92

- NOTES-**
- Unbalanced roof live loads have been considered for this design.
 - Wind: ASCE 7-16; Vult=130mph (3-second gust) Vasd=103mph; TCDL=6.0psf; BCDL=6.0psf; h=25ft; B=45ft; L=24ft; eave=4ft; Cat. II; Exp B; Enclosed; MWFRS (directional) and C-C Exterior(2E) -0-11-0 to 2-1-0, Interior(1) 2-1-0 to 19-2-12 zone; cantilever left and right exposed; end vertical left and right exposed; C-C for members and forces & MWFRS for reactions shown; Lumber DOL=1.60 plate grip DOL=1.60
 - TCLL: ASCE 7-16; Pr=20.0 psf (roof LL: Lum DOL=1.15 Plate DOL=1.15); Pg=20.0 psf; Pf=15.4 psf (Lum DOL = 1.15 Plate DOL = 1.15); Is=1.0; Rough Cat B; Partially Exp.; Ce=1.0; Cs=1.00; Ct=1.10
 - Unbalanced snow loads have been considered for this design.
 - This truss has been designed for greater of min roof live load of 12.0 psf or 1.00 times flat roof load of 15.4 psf on overhangs non-concurrent with other live loads.
 - This truss has been designed for a 10.0 psf bottom chord live load nonconcurrent with any other live loads.
 - * This truss has been designed for a live load of 20.0psf on the bottom chord in all areas where a rectangle 3-6-0 tall by 2-0-0 wide will fit between the bottom chord and any other members, with BCDL = 10.0psf.
 - Refer to girder(s) for truss to truss connections.
 - Provide mechanical connection (by others) of truss to bearing plate capable of withstanding 100 lb uplift at joint(s) 15.
 - This truss is designed in accordance with the 2018 International Residential Code sections R502.11.1 and R802.10.2 and referenced standard ANSI/TPI 1.



April 10, 2026

<p>WARNING - Verify design parameters and READ NOTES ON THIS AND INCLUDED MITEK REFERENCE PAGE MII-7473 rev. 1/2/2023 BEFORE USE.</p> <p>Design valid for use only with MiTek® connectors. This design is based only upon parameters shown, and is for an individual building component, not a truss system. Before use, the building designer must verify the applicability of design parameters and properly incorporate this design into the overall building design. Bracing indicated is to prevent buckling of individual truss web and/or chord members only. Additional temporary and permanent bracing is always required for stability and to prevent collapse with possible personal injury and property damage. For general guidance regarding the fabrication, storage, delivery, erection and bracing of trusses and truss systems, see ANSI/TP1 Quality Criteria and DSB-22 available from Truss Plate Institute (www.tpinst.org) and BCSI Building Component Safety Information available from the Structural Building Component Association (www.sbcacomponents.com)</p>	<p>ENGINEERING BY</p> <p>TRENCO</p> <p>A MITEK Affiliate</p> <p>818 Soundside Road Edenton, NC 27932</p>
--	---

Job 26-1922-A	Truss M02	Truss Type Monopitch	Qty 10	Ply 1	MDP-LOT #16 ROOF	181045310
------------------	--------------	-------------------------	-----------	----------	------------------	-----------

Riverside Roof Truss, LLC, Danville, Va - 24541,

8.830 s Mar 11 2026 MiTek Industries, Inc. Fri Apr 10 06:38:39 2026 Page 1

ID:kk2_eRZGXxvKblGikzSpyNzs9fO-llFe4mdHqwFw7Psf5nVXArTamjVryFcmC3tPk?zSCB_



Scale: 3/4"=1'

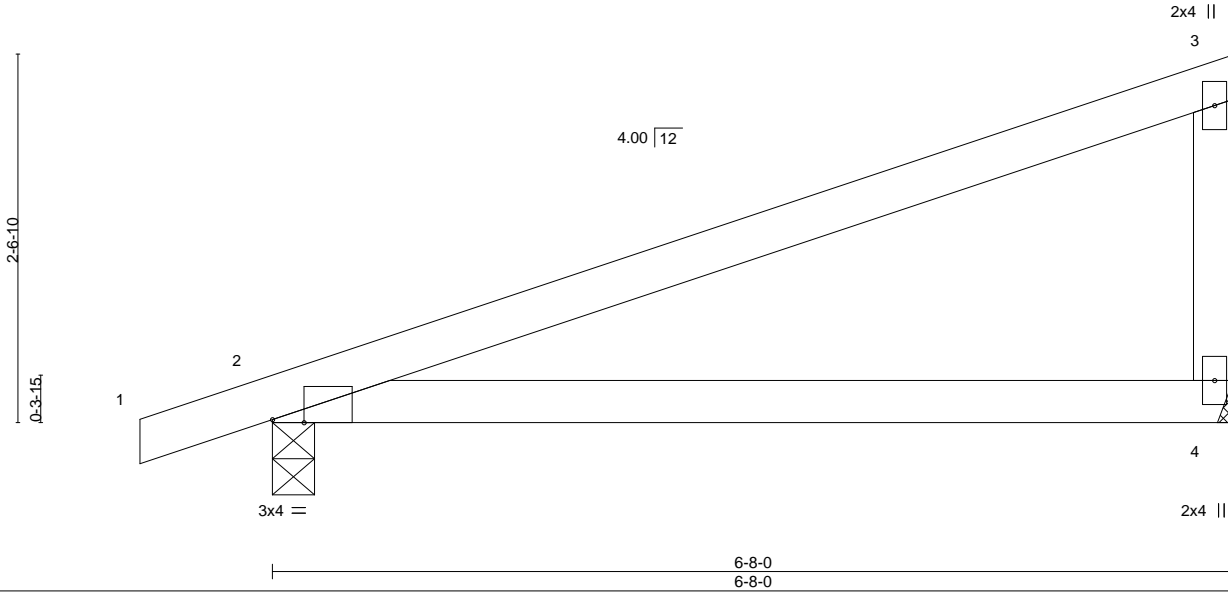

Plate Offsets (X, Y)-- [2:0-2-10, Edge]

LOADING (psf)	SPACING-	CSI.	DEFL.	PLATES	GRIP
TCLL (roof) 20.0	2-0-0	TC 0.79	in (loc) l/defl L/d	MT20	244/190
Snow (Pf/Pg) 15.4/20.0	Plate Grip DOL 1.15	BC 0.61	Vert(LL) -0.11 4-7 >696 240		
TCDL 10.0	Lumber DOL 1.15	WB 0.00	Vert(CT) -0.22 4-7 >358 180		
BCLL 0.0 *	Rep Stress Incr YES	Matrix-MP	Horz(CT) 0.00 2 n/a n/a		
BCDL 10.0	Code IRC2018/TPI2014			Weight: 25 lb	FT = 20%

LUMBER-
 TOP CHORD 2x4 SP No.2
 BOT CHORD 2x4 SP No.2
 WEBS 2x4 SP No.3

BRACING-
 TOP CHORD Structural wood sheathing directly applied or 6-0-0 oc purlins, except end verticals.
 BOT CHORD Rigid ceiling directly applied or 10-0-0 oc bracing.

REACTIONS. (size) 4=Mechanical, 2=0-3-8
 Max Horz 2=81(LC 15)
 Max Uplift 4=-16(LC 16), 2=-45(LC 16)
 Max Grav 4=303(LC 21), 2=340(LC 21)

FORCES. (lb) - Max. Comp./Max. Ten. - All forces 250 (lb) or less except when shown.

NOTES-

- 1) Unbalanced roof live loads have been considered for this design.
- 2) Wind: ASCE 7-16; Vult=130mph (3-second gust) Vasd=103mph; TC DL=6.0psf; BCDL=6.0psf; h=25ft; B=45ft; L=24ft; eave=4ft; Cat. II; Exp B; Enclosed; MWFRS (directional) and C-C Exterior(2E) -0-11-0 to 2-1-0, Interior(1) 2-1-0 to 6-6-4 zone; cantilever left and right exposed; end vertical left and right exposed; C-C for members and forces & MWFRS for reactions shown; Lumber DOL=1.60 plate grip DOL=1.60
- 3) TCLL: ASCE 7-16; Pr=20.0 psf (roof LL: Lum DOL=1.15 Plate DOL=1.15); Pg=20.0 psf; Pf=15.4 psf (Lum DOL = 1.15 Plate DOL = 1.15); Is=1.0; Rough Cat B; Partially Exp.; Ce=1.0; Cs=1.00; Ct=1.10
- 4) Unbalanced snow loads have been considered for this design.
- 5) This truss has been designed for greater of min roof live load of 12.0 psf or 1.00 times flat roof load of 15.4 psf on overhangs non-concurrent with other live loads.
- 6) This truss has been designed for a 10.0 psf bottom chord live load nonconcurrent with any other live loads.
- 7) * This truss has been designed for a live load of 20.0psf on the bottom chord in all areas where a rectangle 3-6-0 tall by 2-0-0 wide will fit between the bottom chord and any other members.
- 8) Refer to girder(s) for truss to truss connections.
- 9) Provide mechanical connection (by others) of truss to bearing plate capable of withstanding 100 lb uplift at joint(s) 4, 2.
- 10) This truss is designed in accordance with the 2018 International Residential Code sections R502.11.1 and R802.10.2 and referenced standard ANSI/TPI 1.



April 10, 2026

WARNING - Verify design parameters and READ NOTES ON THIS AND INCLUDED MITEK REFERENCE PAGE MII-7473 rev. 1/2/2023 BEFORE USE.
 Design valid for use only with MiTek® connectors. This design is based only upon parameters shown, and is for an individual building component, not a truss system. Before use, the building designer must verify the applicability of design parameters and properly incorporate this design into the overall building design. Bracing indicated is to prevent buckling of individual truss web and/or chord members only. Additional temporary and permanent bracing is always required for stability and to prevent collapse with possible personal injury and property damage. For general guidance regarding the fabrication, storage, delivery, erection and bracing of trusses and truss systems, see **ANSI/TPI1 Quality Criteria and DSB-22** available from Truss Plate Institute (www.tpinst.org) and **BCSI Building Component Safety Information** available from the Structural Building Component Association (www.sbcacomponents.com)



Job 26-1922-A	Truss M02GE	Truss Type GABLE	Qty 1	Ply 1	MDP-LOT #16 ROOF	I81045311
Riverside Roof Truss, LLC, Danville, Va - 24541,					8.830 s Mar 11 2026 MiTek Industries, Inc. Fri Apr 10 06:38:40 2026 Page 1	
					Job Reference (optional)	

ID:kk2_eRZGXXvKblGikzSpyNzs9fO-Bxp0H6dvbEnNkZRrfU0mj20wM7_rhitwRjdyFRzSCAz

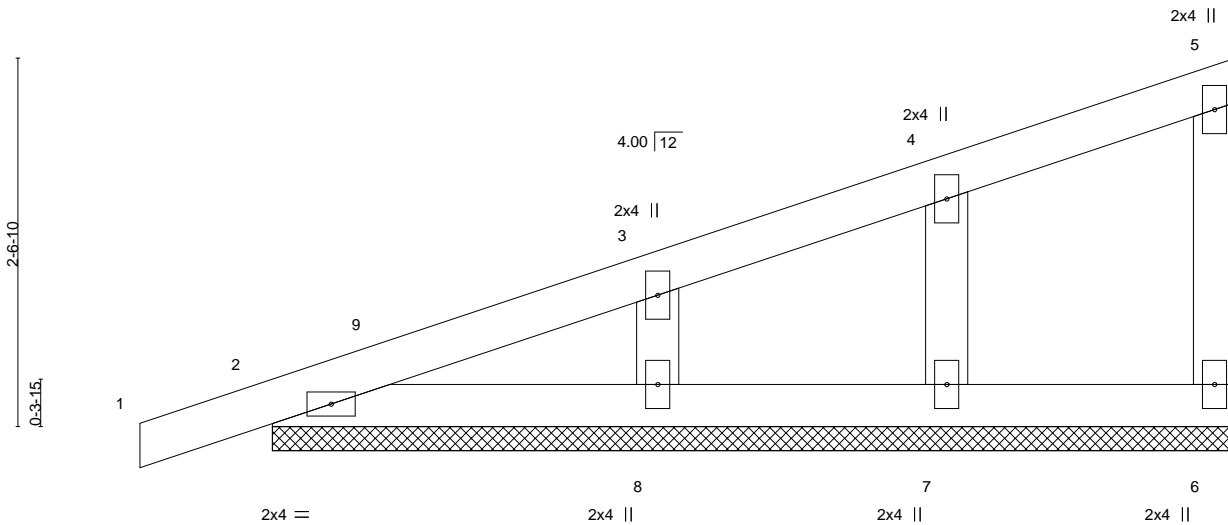

Scale: 3/4"=1'

LOADING (psf)	SPACING-	CSI.	DEFL.	PLATES	GRIP
TCLL (roof) 20.0	2-0-0	TC 0.09	in (loc) l/defl L/d	MT20	244/190
Snow (Pf/Pg) 15.4/20.0	Plate Grip DOL 1.15	BC 0.05	Vert(LL) 0.00 1 n/r 120		
TCDL 10.0	Lumber DOL 1.15	WB 0.06	Vert(CT) 0.00 1 n/r 120		
BCLL 0.0 *	Rep Stress Incr YES	Matrix-P	Horz(CT) 0.00 6 n/a n/a		
BCDL 10.0	Code IRC2018/TPI2014			Weight: 28 lb	FT = 20%

LUMBER-

TOP CHORD	2x4 SP No.2
BOT CHORD	2x4 SP No.2
WEBS	2x4 SP No.3
OTHERS	2x4 SP No.3

BRACING-

TOP CHORD	Structural wood sheathing directly applied or 6-0-0 oc purlins, except end verticals.
BOT CHORD	Rigid ceiling directly applied or 10-0-0 oc bracing.

REACTIONS. All bearings 6-8-0.
 (lb) - Max Horz 2=81(LC 15)
 Max Uplift All uplift 100 lb or less at joint(s) 6, 2, 7, 8
 Max Grav All reactions 250 lb or less at joint(s) 6, 2, 7, 8

FORCES. (lb) - Max. Comp./Max. Ten. - All forces 250 (lb) or less except when shown.

NOTES-

- Unbalanced roof live loads have been considered for this design.
- Wind: ASCE 7-16; Vult=130mph (3-second gust) Vasd=103mph; TC DL=6.0psf; BCDL=6.0psf; h=25ft; B=45ft; L=24ft; eave=2ft; Cat. II; Exp B; Enclosed; MWFRS (directional) and C-C Corner(3E) -0-11-0 to 2-1-0, Exterior(2N) 2-1-0 to 6-6-4 zone; cantilever left and right exposed; end vertical left and right exposed; C-C for members and forces & MWFRS for reactions shown; Lumber DOL=1.60 plate grip DOL=1.60
- Truss designed for wind loads in the plane of the truss only. For studs exposed to wind (normal to the face), see Standard Industry Gable End Details as applicable, or consult qualified building designer as per ANSI/TPI 1.
- TCLL: ASCE 7-16; Pr=20.0 psf (roof LL: Lum DOL=1.15 Plate DOL=1.15); Pg=20.0 psf; Pf=15.4 psf (Lum DOL = 1.15 Plate DOL = 1.15); Is=1.0; Rough Cat B; Partially Exp.; Ce=1.0; Cs=1.00; Ct=1.10
- Unbalanced snow loads have been considered for this design.
- This truss has been designed for greater of min roof live load of 12.0 psf or 1.00 times flat roof load of 15.4 psf on overhangs non-concurrent with other live loads.
- Gable requires continuous bottom chord bearing.
- Gable studs spaced at 2-0-0 oc.
- This truss has been designed for a 10.0 psf bottom chord live load nonconcurrent with any other live loads.
- * This truss has been designed for a live load of 20.0psf on the bottom chord in all areas where a rectangle 3-6-0 tall by 2-0-0 wide will fit between the bottom chord and any other members.
- Provide mechanical connection (by others) of truss to bearing plate capable of withstanding 100 lb uplift at joint(s) 6, 2, 7, 8.
- This truss is designed in accordance with the 2018 International Residential Code sections R502.11.1 and R802.10.2 and referenced standard ANSI/TPI 1.



April 10, 2026

WARNING - Verify design parameters and READ NOTES ON THIS AND INCLUDED MITEK REFERENCE PAGE MII-7473 rev. 1/2/2023 BEFORE USE.

Design valid for use only with MiTek® connectors. This design is based only upon parameters shown, and is for an individual building component, not a truss system. Before use, the building designer must verify the applicability of design parameters and properly incorporate this design into the overall building design. Bracing indicated is to prevent buckling of individual truss web and/or chord members only. Additional temporary and permanent bracing is always required for stability and to prevent collapse with possible personal injury and property damage. For general guidance regarding the fabrication, storage, delivery, erection and bracing of trusses and truss systems, see **ANSI/TPH Quality Criteria and DSB-22** available from Truss Plate Institute (www.tpinst.org) and **BCSI Building Component Safety Information** available from the Structural Building Component Association (www.sbcacomponents.com)



818 Soundside Road
Edenton, NC 27932

Job 26-1922-A	Truss M03	Truss Type Monopitch	Qty 5	Ply 1	MDP-LOT #16 ROOF	81045312
------------------	--------------	-------------------------	----------	----------	------------------	----------

Riverside Roof Truss, LLC, Danville, Va - 24541,

8.830 s Mar 11 2026 MiTek Industries, Inc. Fri Apr 10 06:38:40 2026 Page 1

ID:kk2_eRZGXXvKblGikzSpyNzs9fO-Bxp0H6dvvEnNkZrRfU0mj20pz7rXheWwRjdyFRzSCAz



Scale = 1:20.4

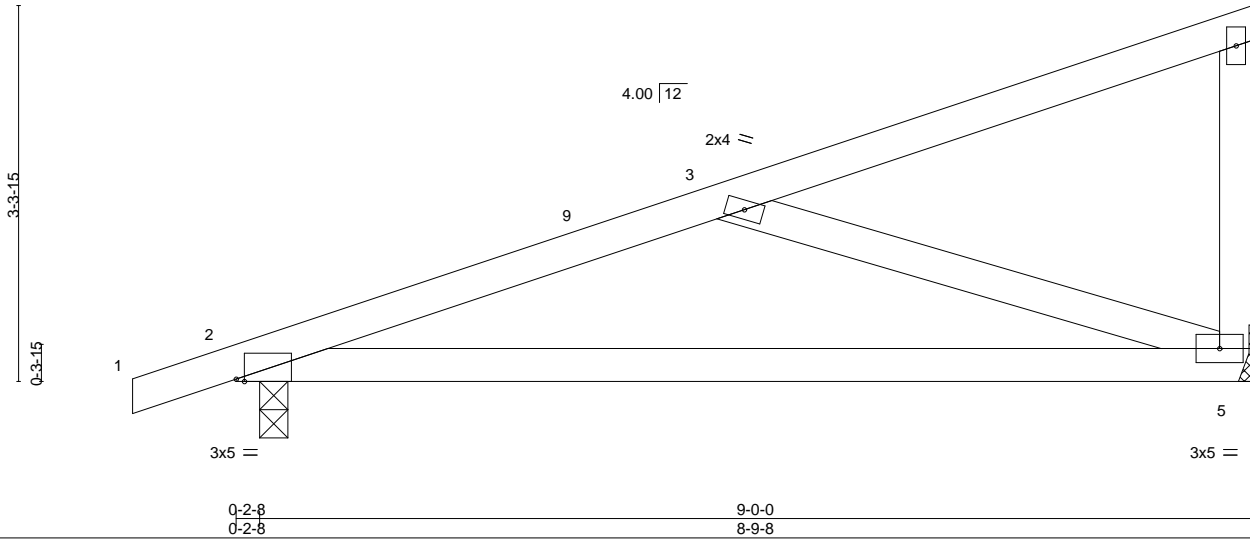

Plate Offsets (X, Y)-- [2:0-0-14, Edge]

LOADING (psf)	SPACING-	CSI.	DEFL.	PLATES	GRIP
TCLL (roof) 20.0	2-0-0	TC 0.56	in (loc) l/defl L/d	MT20	244/190
Snow (Pf/Pg) 15.4/20.0	Plate Grip DOL 1.15	BC 0.58	Vert(LL) -0.13 5-8 >794 240		
TCDL 10.0	Lumber DOL 1.15	WB 0.28	Vert(CT) -0.28 5-8 >385 180		
BCLL 0.0 *	Rep Stress Incr YES	Matrix-MS	Horz(CT) 0.01 5 n/a n/a		
BCDL 10.0	Code IRC2018/TPI2014			Weight: 40 lb	FT = 20%

LUMBER-
 TOP CHORD 2x4 SP No.2
 BOT CHORD 2x4 SP No.2
 WEBS 2x4 SP No.3

BRACING-
 TOP CHORD Structural wood sheathing directly applied or 6-0-0 oc purlins, except end verticals.
 BOT CHORD Rigid ceiling directly applied or 9-6-4 oc bracing.

REACTIONS. (size) 5=Mechanical, 2=0-3-0
 Max Horz 2=108(LC 15)
 Max Uplift 5=-23(LC 16), 2=-49(LC 16)
 Max Grav 5=402(LC 21), 2=412(LC 2)

FORCES. (lb) - Max. Comp./Max. Ten. - All forces 250 (lb) or less except when shown.
 TOP CHORD 2-3=-663/284
 BOT CHORD 2-5=-368/629
 WEBS 3-5=-623/346

- NOTES-**
- Unbalanced roof live loads have been considered for this design.
 - Wind: ASCE 7-16; Vult=130mph (3-second gust) Vasd=103mph; TCCL=6.0psf; BCDL=6.0psf; h=25ft; B=45ft; L=24ft; eave=4ft; Cat. II; Exp B; Enclosed; MWFRS (directional) and C-C Exterior(2E) -0-11-0 to 2-1-0, Interior(1) 2-1-0 to 8-10-4 zone; cantilever left and right exposed; end vertical left and right exposed; C-C for members and forces & MWFRS for reactions shown; Lumber DOL=1.60 plate grip DOL=1.60
 - TCCL: ASCE 7-16; Pr=20.0 psf (roof LL: Lum DOL=1.15 Plate DOL=1.15); Pg=20.0 psf; Pf=15.4 psf (Lum DOL = 1.15 Plate DOL = 1.15); Is=1.0; Rough Cat B; Partially Exp.; Ce=1.0; Cs=1.00; Ct=1.10
 - Unbalanced snow loads have been considered for this design.
 - This truss has been designed for greater of min roof live load of 12.0 psf or 1.00 times flat roof load of 15.4 psf on overhangs non-concurrent with other live loads.
 - This truss has been designed for a 10.0 psf bottom chord live load nonconcurrent with any other live loads.
 - * This truss has been designed for a live load of 20.0psf on the bottom chord in all areas where a rectangle 3-6-0 tall by 2-0-0 wide will fit between the bottom chord and any other members.
 - Refer to girder(s) for truss to truss connections.
 - Provide mechanical connection (by others) of truss to bearing plate capable of withstanding 100 lb uplift at joint(s) 5, 2.
 - This truss is designed in accordance with the 2018 International Residential Code sections R502.11.1 and R802.10.2 and referenced standard ANSI/TPI 1.



April 10, 2026

WARNING - Verify design parameters and READ NOTES ON THIS AND INCLUDED MITEK REFERENCE PAGE MII-7473 rev. 1/2/2023 BEFORE USE.
 Design valid for use only with MiTek® connectors. This design is based only upon parameters shown, and is for an individual building component, not a truss system. Before use, the building designer must verify the applicability of design parameters and properly incorporate this design into the overall building design. Bracing indicated is to prevent buckling of individual truss web and/or chord members only. Additional temporary and permanent bracing is always required for stability and to prevent collapse with possible personal injury and property damage. For general guidance regarding the fabrication, storage, delivery, erection and bracing of trusses and truss systems, see **ANSI/TPH Quality Criteria and DSB-22** available from Truss Plate Institute (www.tpinst.org) and **BCSI Building Component Safety Information** available from the Structural Building Component Association (www.sbcacomponents.com)



Job 26-1922-A	Truss M03GE	Truss Type Monopitch Structural Gable	Qty 1	Ply 1	MDP-LOT #16 ROOF	181045313
------------------	----------------	--	----------	----------	------------------	-----------

Riverside Roof Truss, LLC, Danville, Va - 24541,

8.830 s Mar 11 2026 MiTek Industries, Inc. Fri Apr 10 06:38:41 2026 Page 1

ID:kk2_eRZGXvKblGikzSpyNzs9fO-f8NOVSeXMYvEMj02DCY?FGY_jXAmQ5m3gNMWntzSCAY



Scale = 1:19.3

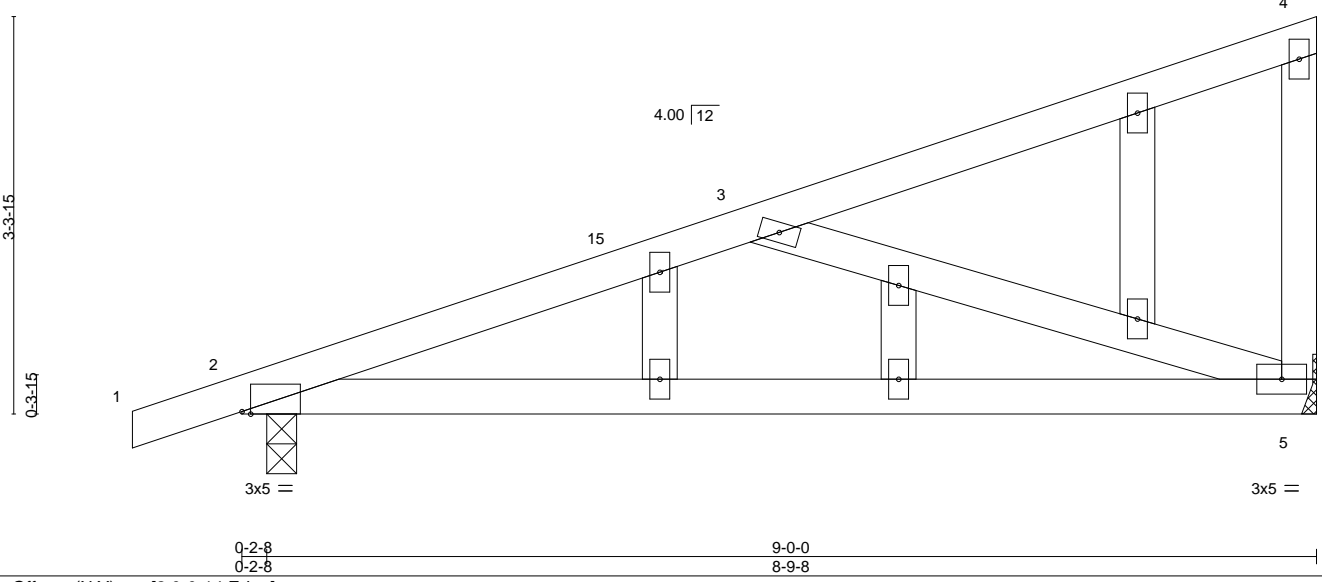

LOADING (psf)	SPACING-	CSI.	DEFL.	PLATES	GRIP
TCLL (roof) 20.0	2-0-0	TC 0.56	in (loc) l/defl L/d	MT20	244/190
Snow (Pf/Pg) 15.4/20.0	Plate Grip DOL 1.15	BC 0.58	Vert(LL) -0.13 5-14 >794 240		
TCDL 10.0	Lumber DOL 1.15	WB 0.28	Vert(CT) -0.28 5-14 >385 180		
BCLL 0.0 *	Rep Stress Incr YES	Matrix-MS	Horz(CT) 0.01 5 n/a n/a		
BCDL 10.0	Code IRC2018/TPI2014			Weight: 45 lb	FT = 20%

LUMBER-	BRACING-
TOP CHORD 2x4 SP No.2	TOP CHORD Structural wood sheathing directly applied or 6-0-0 oc purlins, except end verticals.
BOT CHORD 2x4 SP No.2	BOT CHORD Rigid ceiling directly applied or 9-6-4 oc bracing.
WEBS 2x4 SP No.3	
OTHERS 2x4 SP No.3	

REACTIONS. (size) 5=Mechanical, 2=0-3-0
 Max Horz 2=108(LC 15)
 Max Uplift 5=-23(LC 16), 2=-49(LC 16)
 Max Grav 5=402(LC 21), 2=412(LC 2)

FORCES. (lb) - Max. Comp./Max. Ten. - All forces 250 (lb) or less except when shown.
 TOP CHORD 2-3=-663/284
 BOT CHORD 2-5=-368/629
 WEBS 3-5=-623/346

NOTES-

- 1) Unbalanced roof live loads have been considered for this design.
- 2) Wind: ASCE 7-16; Vult=130mph (3-second gust) Vasd=103mph; TCDL=6.0psf; BCDL=6.0psf; h=25ft; B=45ft; L=24ft; eave=4ft; Cat. II; Exp B; Enclosed; MWFRS (directional) and C-C Exterior(2E) -0-11-0 to 2-1-0, Interior(1) 2-1-0 to 8-10-4 zone; cantilever left and right exposed ; end vertical left and right exposed;C-C for members and forces & MWFRS for reactions shown; Lumber DOL=1.60 plate grip DOL=1.60
- 3) Truss designed for wind loads in the plane of the truss only. For studs exposed to wind (normal to the face), see Standard Industry Gable End Details as applicable, or consult qualified building designer as per ANSI/TPI 1.
- 4) TCLL: ASCE 7-16; Pr=20.0 psf (roof LL: Lum DOL=1.15 Plate DOL=1.15); Pg=20.0 psf; Pf=15.4 psf (Lum DOL = 1.15 Plate DOL = 1.15); Is=1.0; Rough Cat B; Partially Exp.; Ce=1.0; Cs=1.00; Ct=1.10
- 5) Unbalanced snow loads have been considered for this design.
- 6) This truss has been designed for greater of min roof live load of 12.0 psf or 1.00 times flat roof load of 15.4 psf on overhangs non-concurrent with other live loads.
- 7) All plates are 2x4 MT20 unless otherwise indicated.
- 8) Gable studs spaced at 2-0-0 oc.
- 9) This truss has been designed for a 10.0 psf bottom chord live load nonconcurrent with any other live loads.
- 10) * This truss has been designed for a live load of 20.0psf on the bottom chord in all areas where a rectangle 3-6-0 tall by 2-0-0 wide will fit between the bottom chord and any other members.
- 11) Refer to girder(s) for truss to truss connections.
- 12) Provide mechanical connection (by others) of truss to bearing plate capable of withstanding 100 lb uplift at joint(s) 5, 2.
- 13) This truss is designed in accordance with the 2018 International Residential Code sections R502.11.1 and R802.10.2 and referenced standard ANSI/TPI 1.



April 10, 2026

Job 26-1922-A	Truss M04	Truss Type Monopitch	Qty 5	Ply 1	MDP-LOT #16 ROOF Job Reference (optional)	I81045314
------------------	--------------	-------------------------	----------	----------	--	-----------

Riverside Roof Truss, LLC,

Danville, Va - 24541,

8.830 s Mar 11 2026 MiTek Industries, Inc. Fri Apr 10 06:38:41 2026 Page 1

ID:kk2_eRZGXXvKblGikzSpyNzs9fO-f8NOVSeXMYvEMj02DCY?FGY0PXEpQ963gNMWntzSCAY

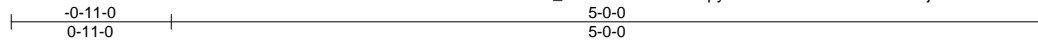

Scale = 1:13.2

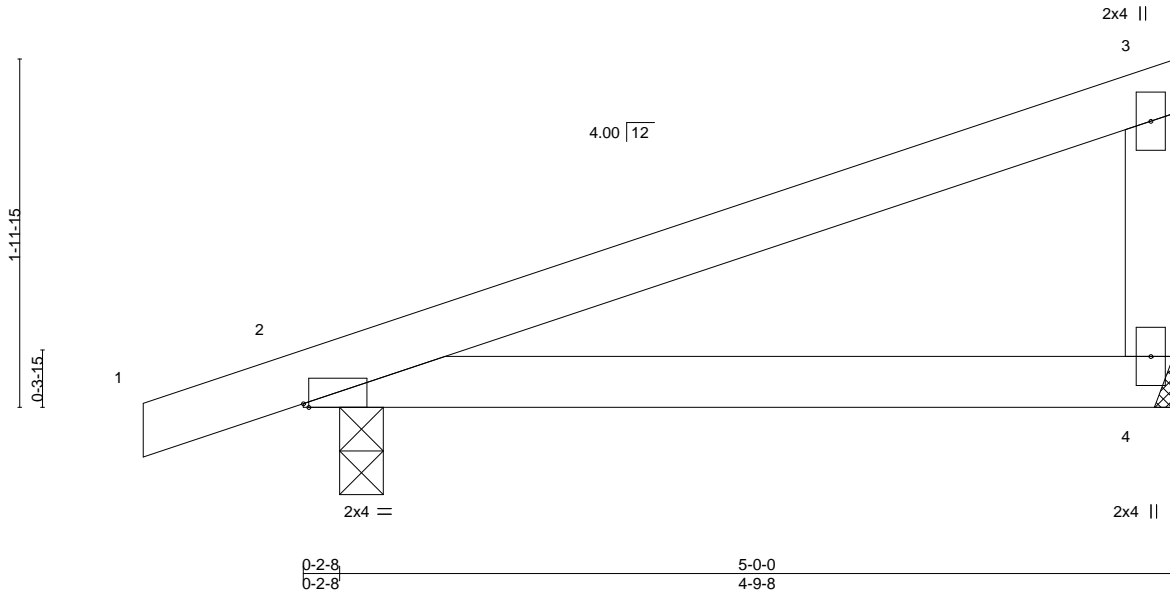

Plate Offsets (X,Y)-- [2:0-0-6,Edge]

LOADING (psf)	SPACING-	CSI.	DEFL.	PLATES	GRIP
TCLL (roof) 20.0	2-0-0	TC 0.39	in (loc) l/defl L/d	MT20	244/190
Snow (Pf/Pg) 15.4/20.0	Plate Grip DOL 1.15	BC 0.33	Vert(LL) -0.03 4-7 >999 240		
TCDL 10.0	Lumber DOL 1.15	WB 0.00	Vert(CT) -0.07 4-7 >882 180		
BCLL 0.0 *	Rep Stress Incr YES	Matrix-MP	Horz(CT) 0.00 2 n/a n/a		
BCDL 10.0	Code IRC2018/TPI2014			Weight: 19 lb	FT = 20%

LUMBER-
 TOP CHORD 2x4 SP No.2
 BOT CHORD 2x4 SP No.2
 WEBS 2x4 SP No.3

BRACING-
 TOP CHORD Structural wood sheathing directly applied or 5-0-0 oc purlins, except end verticals.
 BOT CHORD Rigid ceiling directly applied or 10-0-0 oc bracing.

REACTIONS. (size) 4=Mechanical, 2=0-3-0
 Max Horz 2=62(LC 15)
 Max Uplift 4=-10(LC 16), 2=-42(LC 16)
 Max Grav 4=223(LC 21), 2=304(LC 21)

FORCES. (lb) - Max. Comp./Max. Ten. - All forces 250 (lb) or less except when shown.

- NOTES-**
- Unbalanced roof live loads have been considered for this design.
 - Wind: ASCE 7-16; Vult=130mph (3-second gust) Vasd=103mph; TCCL=6.0psf; BCDL=6.0psf; h=25ft; B=45ft; L=24ft; eave=4ft; Cat. II; Exp B; Enclosed; MWFRS (directional) and C-C Exterior(2E) -0-11-0 to 2-1-0, Interior(1) 2-1-0 to 4-10-4 zone; cantilever left and right exposed; end vertical left and right exposed; C-C for members and forces & MWFRS for reactions shown; Lumber DOL=1.60 plate grip DOL=1.60
 - TCLL: ASCE 7-16; Pr=20.0 psf (roof LL: Lum DOL=1.15 Plate DOL=1.15); Pg=20.0 psf; Pf=15.4 psf (Lum DOL = 1.15 Plate DOL = 1.15); Is=1.0; Rough Cat B; Partially Exp.; Ce=1.0; Cs=1.00; Ct=1.10
 - Unbalanced snow loads have been considered for this design.
 - This truss has been designed for greater of min roof live load of 12.0 psf or 1.00 times flat roof load of 15.4 psf on overhangs non-concurrent with other live loads.
 - This truss has been designed for a 10.0 psf bottom chord live load nonconcurrent with any other live loads.
 - * This truss has been designed for a live load of 20.0psf on the bottom chord in all areas where a rectangle 3-6-0 tall by 2-0-0 wide will fit between the bottom chord and any other members.
 - Refer to girder(s) for truss to truss connections.
 - Provide mechanical connection (by others) of truss to bearing plate capable of withstanding 100 lb uplift at joint(s) 4, 2.
 - This truss is designed in accordance with the 2018 International Residential Code sections R502.11.1 and R802.10.2 and referenced standard ANSI/TPI 1.



April 10, 2026

WARNING - Verify design parameters and READ NOTES ON THIS AND INCLUDED MITEK REFERENCE PAGE MII-7473 rev. 1/2/2023 BEFORE USE.
 Design valid for use only with MiTek® connectors. This design is based only upon parameters shown, and is for an individual building component, not a truss system. Before use, the building designer must verify the applicability of design parameters and properly incorporate this design into the overall building design. Bracing indicated is to prevent buckling of individual truss web and/or chord members only. Additional temporary and permanent bracing is always required for stability and to prevent collapse with possible personal injury and property damage. For general guidance regarding the fabrication, storage, delivery, erection and bracing of trusses and truss systems, see **ANSI/TPH Quality Criteria and DSB-22** available from Truss Plate Institute (www.tpinst.org) and **BCSI Building Component Safety Information** available from the Structural Building Component Association (www.sbcacomponents.com)



818 Soundside Road
 Edenton, NC 27932

Job 26-1922-A	Truss M04GE	Truss Type Monopitch Structural Gable	Qty 1	Ply 1	MDP-LOT #16 ROOF Job Reference (optional)	I81045315
------------------	----------------	--	----------	----------	--	-----------

Riverside Roof Truss, LLC, Danville, Va - 24541,

8.830 s Mar 11 2026 MiTek Industries, Inc. Fri Apr 10 06:38:42 2026 Page 1
ID:kk2_eRZGXxvKblGikzSpyNzs9fO-7KxmiofA7r15_tbEnv3FoT5B9xa29cMCu163KKzSCAx

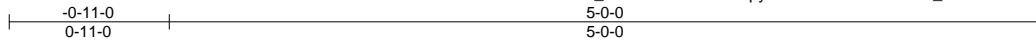

Scale = 1:13.2

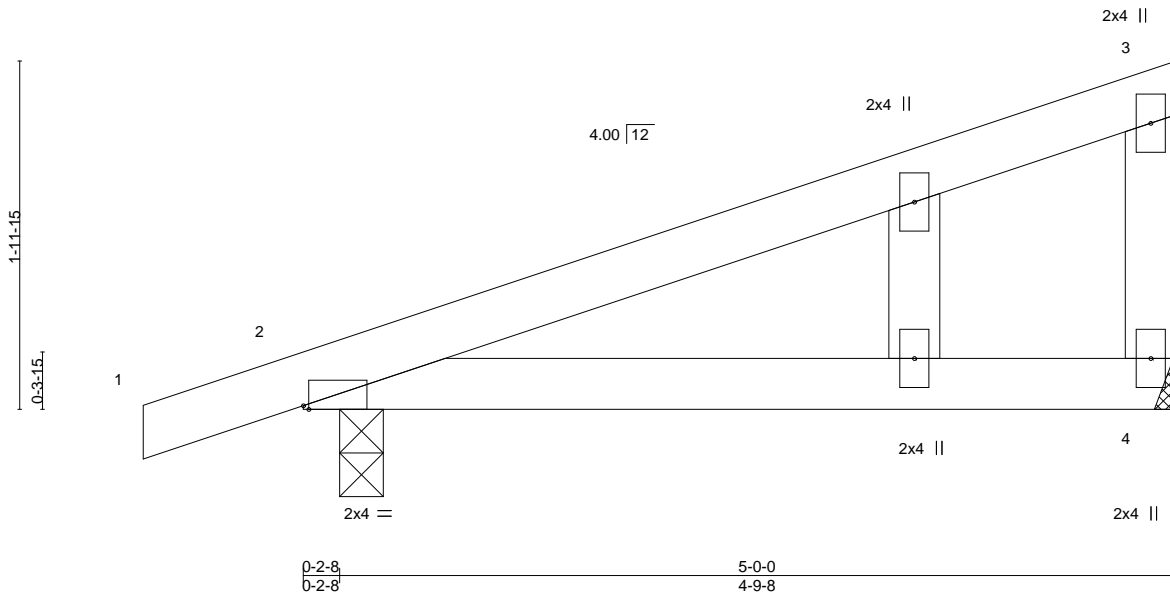

LOADING (psf)		SPACING-	2-0-0	CSI.		DEFL.	in (loc)	l/defl	L/d	PLATES	GRIP
TCLL (roof)	20.0	Plate Grip DOL	1.15	TC	0.39	Vert(LL)	-0.03	4-9	>999	MT20	244/190
Snow (Pf/Pg)	15.4/20.0	Lumber DOL	1.15	BC	0.33	Vert(CT)	-0.07	4-9	>882		
TCDL	10.0	Rep Stress Incr	YES	WB	0.00	Horz(CT)	0.00	2	n/a		
BCLL	0.0 *	Code IRC2018/TPI2014		Matrix-MP						Weight: 20 lb	FT = 20%
BCDL	10.0										

LUMBER-		BRACING-	
TOP CHORD	2x4 SP No.2	TOP CHORD	Structural wood sheathing directly applied or 5-0-0 oc purlins, except end verticals.
BOT CHORD	2x4 SP No.2	BOT CHORD	Rigid ceiling directly applied or 10-0-0 oc bracing.
WEBS	2x4 SP No.3		
OTHERS	2x4 SP No.3		

REACTIONS. (size) 4=Mechanical, 2=0-3-0
 Max Horz 2=62(LC 15)
 Max Uplift 4=-10(LC 16), 2=-42(LC 16)
 Max Grav 4=223(LC 21), 2=304(LC 21)

FORCES. (lb) - Max. Comp./Max. Ten. - All forces 250 (lb) or less except when shown.

NOTES-

- 1) Unbalanced roof live loads have been considered for this design.
- 2) Wind: ASCE 7-16; Vult=130mph (3-second gust) Vasd=103mph; TCDL=6.0psf; BCDL=6.0psf; h=25ft; B=45ft; L=24ft; eave=4ft; Cat. II; Exp B; Enclosed; MWFRS (directional) and C-C Exterior(2E) -0-11-0 to 2-1-0, Interior(1) 2-1-0 to 4-10-4 zone; cantilever left and right exposed ; end vertical left and right exposed;C-C for members and forces & MWFRS for reactions shown; Lumber DOL=1.60 plate grip DOL=1.60
- 3) Truss designed for wind loads in the plane of the truss only. For studs exposed to wind (normal to the face), see Standard Industry Gable End Details as applicable, or consult qualified building designer as per ANSI/TPI 1.
- 4) TCLL: ASCE 7-16; Pr=20.0 psf (roof LL: Lum DOL=1.15 Plate DOL=1.15); Pg=20.0 psf; Pf=15.4 psf (Lum DOL = 1.15 Plate DOL = 1.15); Is=1.0; Rough Cat B; Partially Exp.; Ce=1.0; Cs=1.00; Ct=1.10
- 5) Unbalanced snow loads have been considered for this design.
- 6) This truss has been designed for greater of min roof live load of 12.0 psf or 1.00 times flat roof load of 15.4 psf on overhangs non-concurrent with other live loads.
- 7) Gable studs spaced at 2-0-0 oc.
- 8) This truss has been designed for a 10.0 psf bottom chord live load nonconcurrent with any other live loads.
- 9) * This truss has been designed for a live load of 20.0psf on the bottom chord in all areas where a rectangle 3-6-0 tall by 2-0-0 wide will fit between the bottom chord and any other members.
- 10) Refer to girder(s) for truss to truss connections.
- 11) Provide mechanical connection (by others) of truss to bearing plate capable of withstanding 100 lb uplift at joint(s) 4, 2.
- 12) This truss is designed in accordance with the 2018 International Residential Code sections R502.11.1 and R802.10.2 and referenced standard ANSI/TPI 1.

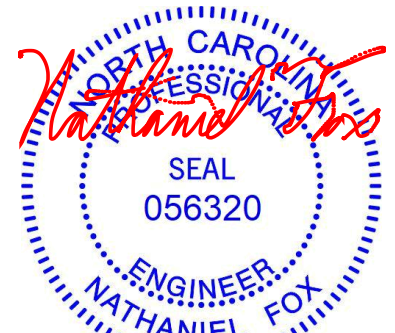

April 10, 2026

WARNING - Verify design parameters and READ NOTES ON THIS AND INCLUDED MITEK REFERENCE PAGE MII-7473 rev. 1/2/2023 BEFORE USE.

Design valid for use only with MiTek® connectors. This design is based only upon parameters shown, and is for an individual building component, not a truss system. Before use, the building designer must verify the applicability of design parameters and properly incorporate this design into the overall building design. Bracing indicated is to prevent buckling of individual truss web and/or chord members only. Additional temporary and permanent bracing is always required for stability and to prevent collapse with possible personal injury and property damage. For general guidance regarding the fabrication, storage, delivery, erection and bracing of trusses and truss systems, see **ANSI/TPI1 Quality Criteria and DSB-22** available from Truss Plate Institute (www.tpinst.org) and **BCSI Building Component Safety Information** available from the Structural Building Component Association (www.sbcacomponents.com)



818 Soundside Road
Edenton, NC 27932

Job 26-1922-A	Truss M05	Truss Type Monopitch	Qty 3	Ply 1	MDP-LOT #16 ROOF Job Reference (optional)	I81045316
------------------	--------------	-------------------------	----------	----------	--	-----------

Riverside Roof Truss, LLC, Danville, Va - 24541,

8.830 s Mar 11 2026 MiTek Industries, Inc. Fri Apr 10 06:38:42 2026 Page 1

ID:kk2_eRZGXvKblGikzSpyNzs9fO-7KxmiofA7r15_tbEnv3FoT5Doxdb9cVCu163KKzSCAx



Scale = 1:17.9

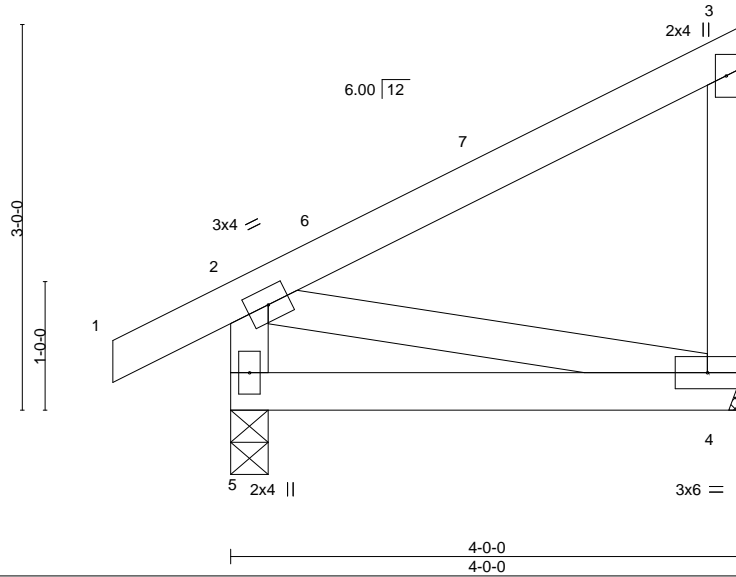

LOADING (psf)	SPACING-	CSI.	DEFL.	PLATES	GRIP
TCLL (roof) 20.0	2-0-0	TC 0.29	in (loc) l/defl L/d	MT20	244/190
Snow (Pf/Pg) 15.4/20.0	Plate Grip DOL 1.15	BC 0.16	Vert(LL) -0.01 4-5 >999 240		
TCDL 10.0	Lumber DOL 1.15	WB 0.06	Vert(CT) -0.02 4-5 >999 180		
BCLL 0.0 *	Rep Stress Incr YES	Matrix-MP	Horz(CT) -0.00 4 n/a n/a		
BCDL 10.0	Code IRC2018/TPI2014			Weight: 24 lb	FT = 20%

LUMBER-
TOP CHORD 2x4 SP No.2
BOT CHORD 2x4 SP No.2
WEBS 2x4 SP No.3

BRACING-
TOP CHORD Structural wood sheathing directly applied or 4-0-0 oc purlins, except end verticals.
BOT CHORD Rigid ceiling directly applied or 10-0-0 oc bracing.

REACTIONS. (size) 5=0-3-8, 4=Mechanical
Max Horz 5=97(LC 13)
Max Uplift 5=-39(LC 16), 4=-26(LC 13)
Max Grav 5=279(LC 21), 4=171(LC 21)

FORCES. (lb) - Max. Comp./Max. Ten. - All forces 250 (lb) or less except when shown.

NOTES-

- 1) Unbalanced roof live loads have been considered for this design.
- 2) Wind: ASCE 7-16; Vult=130mph (3-second gust) Vasd=103mph; TCDL=6.0psf; BCDL=6.0psf; h=25ft; B=45ft; L=24ft; eave=4ft; Cat. II; Exp B; Enclosed; MWFRS (directional) and C-C Exterior(2E) -0-11-0 to 2-1-0, Interior(1) 2-1-0 to 3-10-4 zone; cantilever left and right exposed; end vertical left and right exposed; C-C for members and forces & MWFRS for reactions shown; Lumber DOL=1.60 plate grip DOL=1.60
- 3) TCLL: ASCE 7-16; Pr=20.0 psf (roof LL: Lum DOL=1.15 Plate DOL=1.15); Pg=20.0 psf; Pf=15.4 psf (Lum DOL = 1.15 Plate DOL = 1.15); Is=1.0; Rough Cat B; Partially Exp.; Ce=1.0; Cs=1.00; Ct=1.10
- 4) Unbalanced snow loads have been considered for this design.
- 5) This truss has been designed for greater of min roof live load of 12.0 psf or 1.00 times flat roof load of 15.4 psf on overhangs non-concurrent with other live loads.
- 6) This truss has been designed for a 10.0 psf bottom chord live load nonconcurrent with any other live loads.
- 7) * This truss has been designed for a live load of 20.0psf on the bottom chord in all areas where a rectangle 3-6-0 tall by 2-0-0 wide will fit between the bottom chord and any other members.
- 8) Refer to girder(s) for truss to truss connections.
- 9) Provide mechanical connection (by others) of truss to bearing plate capable of withstanding 100 lb uplift at joint(s) 5, 4.
- 10) This truss is designed in accordance with the 2018 International Residential Code sections R502.11.1 and R802.10.2 and referenced standard ANSI/TPI 1.



April 10, 2026

WARNING - Verify design parameters and READ NOTES ON THIS AND INCLUDED MITEK REFERENCE PAGE MII-7473 rev. 1/2/2023 BEFORE USE.

Design valid for use only with MiTek® connectors. This design is based only upon parameters shown, and is for an individual building component, not a truss system. Before use, the building designer must verify the applicability of design parameters and properly incorporate this design into the overall building design. Bracing indicated is to prevent buckling of individual truss web and/or chord members only. Additional temporary and permanent bracing is always required for stability and to prevent collapse with possible personal injury and property damage. For general guidance regarding the fabrication, storage, delivery, erection and bracing of trusses and truss systems, see **ANSI/TPH Quality Criteria and DSB-22** available from Truss Plate Institute (www.tpinst.org) and **BCSI Building Component Safety Information** available from the Structural Building Component Association (www.sbcacomponents.com)



818 Soundside Road
Edenton, NC 27932

Job 26-1922-A	Truss SM02	Truss Type Half Hip	Qty 1	Ply 1	MDP-LOT #16 ROOF	81045318
------------------	---------------	------------------------	----------	----------	------------------	----------

Riverside Roof Truss, LLC,

Danville, Va - 24541,

8.830 s Mar 11 2026 MiTek Industries, Inc. Fri Apr 10 06:38:43 2026 Page 1

ID:kk2_eRZGXvKblGikzSpyNzs9fO-bWV8w8gou99yb0AQKdaUKhelbKvju_qM7hrdmszSCAW

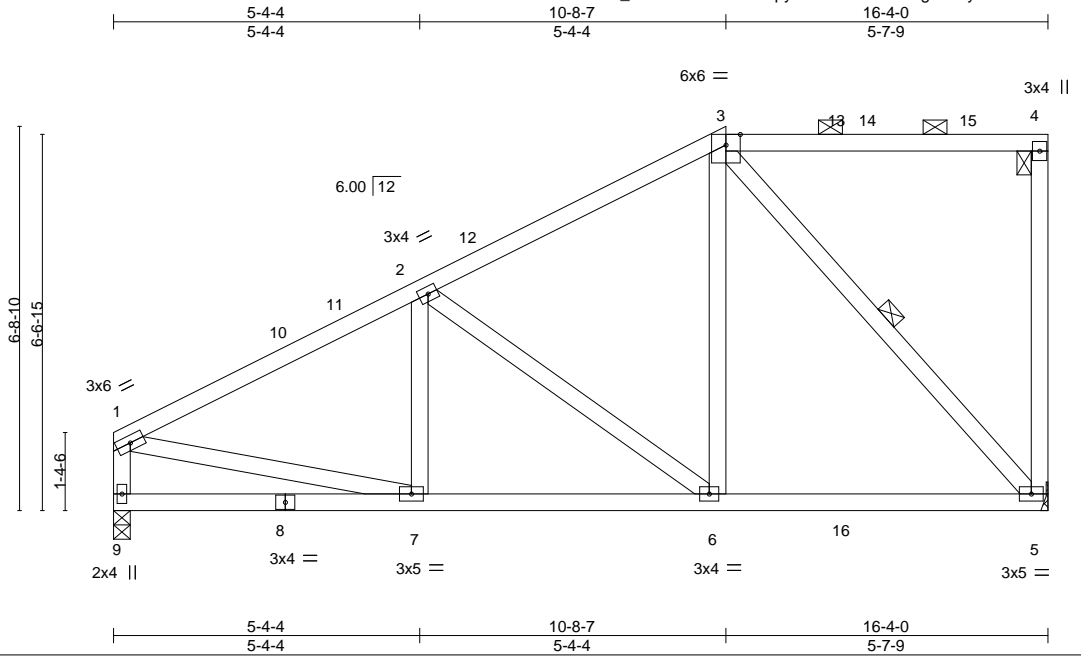

Scale = 1:40.3

LOADING (psf)	SPACING-	CSI.	DEFL.	PLATES	GRIP
TCLL (roof) 20.0	2-0-0	TC 0.67	in (loc) l/defl L/d	MT20	244/190
Snow (Pf/Pg) 20.4/20.0	Plate Grip DOL 1.15	BC 0.43	Vert(LL) -0.04 5-6 >999 240		
TCDL 10.0	Lumber DOL 1.15	WB 0.37	Vert(CT) -0.08 5-6 >999 180		
BCLL 0.0 *	Rep Stress Incr YES	Matrix-MS	Horz(CT) 0.01 5 n/a n/a		
BCDL 10.0	Code IRC2018/TPI2014			Weight: 104 lb	FT = 20%

LUMBER-
 TOP CHORD 2x4 SP No.2
 BOT CHORD 2x4 SP No.2
 WEBS 2x4 SP No.3

BRACING-
 TOP CHORD Structural wood sheathing directly applied or 5-3-14 oc purlins, except end verticals, and 2-0-0 oc purlins (6-0-0 max.): 3-4.
 BOT CHORD Rigid ceiling directly applied or 10-0-0 oc bracing.
 WEBS 1 Row at midpt 3-5

REACTIONS. (size) 5=Mechanical, 9=0-3-8
 Max Horz 9=217(LC 15)
 Max Uplift 5=92(LC 13), 9=32(LC 16)
 Max Grav 5=753(LC 38), 9=839(LC 39)

FORCES. (lb) - Max. Comp./Max. Ten. - All forces 250 (lb) or less except when shown.
 TOP CHORD 1-2=-1021/129, 2-3=-631/153, 1-9=-755/127
 BOT CHORD 7-9=-347/315, 6-7=-304/904, 5-6=-198/500
 WEBS 2-6=-482/131, 3-6=0/517, 3-5=-726/186, 1-7=-42/740

- NOTES-**
- 1) Unbalanced roof live loads have been considered for this design.
 - 2) Wind: ASCE 7-16; Vult=130mph (3-second gust) Vasd=103mph; TCDL=6.0psf; BCDL=6.0psf; h=25ft; B=45ft; L=24ft; eave=4ft; Cat. II; Exp B; Enclosed; MWFRS (directional) and C-C Exterior(2E) 0-1-12 to 3-1-12, Interior(1) 3-1-12 to 10-8-7, Exterior(2R) 10-8-7 to 14-11-6, Interior(1) 14-11-6 to 16-2-4 zone; cantilever left and right exposed ; end vertical left and right exposed; C-C for members and forces & MWFRS for reactions shown; Lumber DOL=1.60 plate grip DOL=1.60
 - 3) TCLL: ASCE 7-16; Pr=20.0 psf (roof LL: Lum DOL=1.15 Plate DOL=1.15); Pg=20.0 psf; Pf=20.4 psf (Lum DOL = 1.15 Plate DOL = 1.15); Is=1.0; Rough Cat B; Partially Exp.; Ce=1.0; Cs=1.00; Ct=1.10, Lu=50-0-0; Min. flat roof snow load governs. Rain surcharge applied to all exposed surfaces with slopes less than 0.500/12 in accordance with IBC 1608.3.4.
 - 4) Unbalanced snow loads have been considered for this design.
 - 5) Provide adequate drainage to prevent water ponding.
 - 6) This truss has been designed for a 10.0 psf bottom chord live load nonconcurrent with any other live loads.
 - 7) * This truss has been designed for a live load of 20.0psf on the bottom chord in all areas where a rectangle 3-6-0 tall by 2-0-0 wide will fit between the bottom chord and any other members, with BCDL = 10.0psf.
 - 8) Refer to girder(s) for truss to truss connections.
 - 9) Provide mechanical connection (by others) of truss to bearing plate capable of withstanding 100 lb uplift at joint(s) 5, 9.
 - 10) This truss is designed in accordance with the 2018 International Residential Code sections R502.11.1 and R802.10.2 and referenced standard ANSI/TPI 1.
 - 11) Graphical purlin representation does not depict the size or the orientation of the purlin along the top and/or bottom chord.



April 10, 2026

Job 26-1922-A	Truss SM03	Truss Type Half Hip	Qty 1	Ply 1	MDP-LOT #16 ROOF	I81045319
------------------	---------------	------------------------	----------	----------	------------------	-----------

Riverside Roof Truss, LLC,

Danville, Va - 24541,

8.830 s Mar 11 2026 MiTek Industries, Inc. Fri Apr 10 06:38:44 2026 Page 1

ID:kk2_eRZGXvKbGikzSpyNzs9fO-3i3X7UhQfHpDAlduK5jtuAQjk8jdPuVMLbAOCzSCAV



Scale = 1:44.8

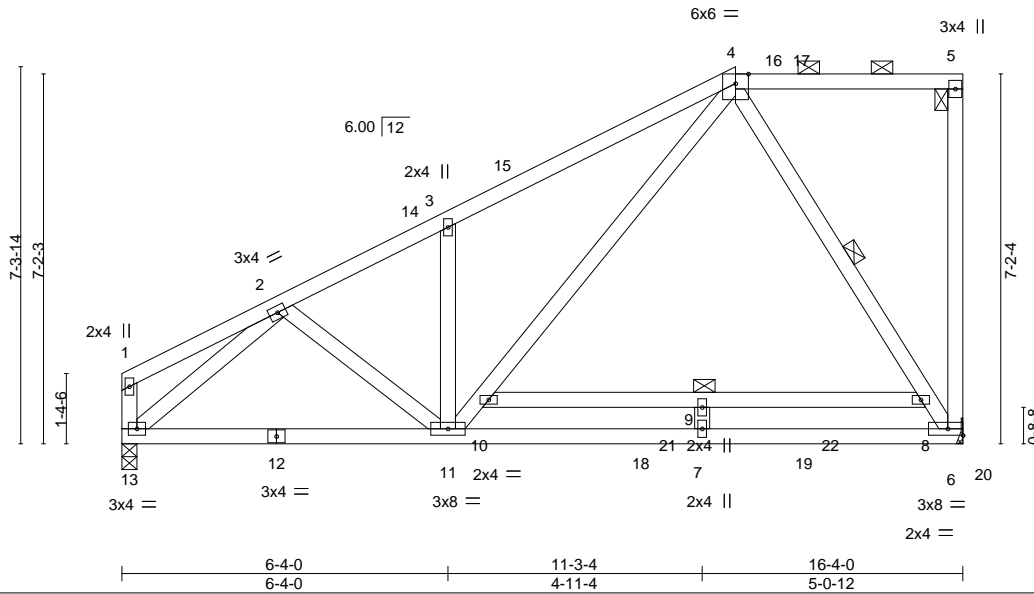

LOADING (psf)	SPACING-	CSI.	DEFL.	PLATES	GRIP
TCLL (roof) 20.0	2-0-0	TC 0.84	in (loc) l/defl L/d	MT20	244/190
Snow (Pf/Pg) 20.4/20.0	Plate Grip DOL 1.15	BC 0.89	Vert(LL) -0.42 6-7 >461 240		
TCDL 10.0	Lumber DOL 1.15	WB 0.51	Vert(CT) -0.69 6-7 >278 180		
BCLL 0.0 *	Rep Stress Incr YES	Matrix-MS	Horz(CT) 0.02 6 n/a n/a		
BCDL 10.0	Code IRC2018/TPI2014			Weight: 117 lb	FT = 20%

LUMBER-
 TOP CHORD 2x4 SP No.2
 BOT CHORD 2x4 SP No.1 *Except*
 12-13: 2x4 SP No.2
 WEBS 2x4 SP No.3

BRACING-
 TOP CHORD Structural wood sheathing directly applied or 4-6-8 oc purlins, except end verticals, and 2-0-0 oc purlins (6-0-0 max.): 4-5.
 BOT CHORD Rigid ceiling directly applied or 10-0-0 oc bracing. Except: 6-0-0 oc bracing: 8-10
 WEBS 1 Row at midpt 4-6

REACTIONS. (size) 6=Mechanical, 13=0-3-8
 Max Horz 13=238(LC 15)
 Max Uplift 6=-13(LC 13)
 Max Grav 6=1007(LC 39), 13=964(LC 39)

FORCES. (lb) - Max. Comp./Max. Ten. - All forces 250 (lb) or less except when shown.
 TOP CHORD 2-3=-1200/65, 3-4=-1270/151
 BOT CHORD 11-13=-291/982, 7-11=-155/531, 6-7=-155/531
 WEBS 3-11=-452/167, 10-11=-113/901, 4-10=-52/1095, 4-8=-712/221, 6-8=-908/160, 2-13=-1153/45

NOTES-

- 1) Unbalanced roof live loads have been considered for this design.
- 2) Wind: ASCE 7-16; Vult=130mph (3-second gust) Vasd=103mph; TCDL=6.0psf; BCDL=6.0psf; h=25ft; B=45ft; L=24ft; eave=4ft; Cat. II; Exp B; Enclosed; MWFRS (directional) and C-C Exterior(2E) 0-1-12 to 3-0-7, Interior(1) 3-0-7 to 11-11-0, Exterior(2E) 11-11-0 to 16-2-4 zone; cantilever left and right exposed ; end vertical left and right exposed;C-C for members and forces & MWFRS for reactions shown; Lumber DOL=1.60 plate grip DOL=1.60
- 3) TCLL: ASCE 7-16; Pr=20.0 psf (roof LL: Lum DOL=1.15 Plate DOL=1.15); Pg=20.0 psf; Pf=20.4 psf (Lum DOL = 1.15 Plate DOL = 1.15); Is=1.0; Rough Cat B; Partially Exp.; Ce=1.0; Cs=1.00; Ct=1.10, Lu=50-0-0; Min. flat roof snow load governs. Rain surcharge applied to all exposed surfaces with slopes less than 0.500/12 in accordance with IBC 1608.3.4.
- 4) Unbalanced snow loads have been considered for this design.
- 5) Provide adequate drainage to prevent water ponding.
- 6) This truss has been designed for a 10.0 psf bottom chord live load nonconcurrent with any other live loads.
- 7) * This truss has been designed for a live load of 20.0psf on the bottom chord in all areas where a rectangle 3-6-0 tall by 2-0-0 wide will fit between the bottom chord and any other members, with BCDL = 10.0psf.
- 8) Refer to girder(s) for truss to truss connections.
- 9) Provide mechanical connection (by others) of truss to bearing plate capable of withstanding 100 lb uplift at joint(s) 6.
- 10) This truss is designed in accordance with the 2018 International Residential Code sections R502.11.1 and R802.10.2 and referenced standard ANSI/TPI 1.
- 11) Graphical purlin representation does not depict the size or the orientation of the purlin along the top and/or bottom chord.



April 10, 2026

Job 26-1922-A	Truss T01	Truss Type Common	Qty 10	Ply 1	MDP-LOT #16 ROOF	181045320
------------------	--------------	----------------------	-----------	----------	------------------	-----------

Riverside Roof Truss, LLC, Danville, Va - 24541,

8.830 s Mar 11 2026 MiTek Industries, Inc. Fri Apr 10 06:38:45 2026 Page 1
ID:kk2_eRZGXXvKblGikzSpyNzs9fO-XvdvKqh2QmPfrKKpS1cyQ6jw8XnMxHfb?KjwezSCAu

Job Reference (optional)

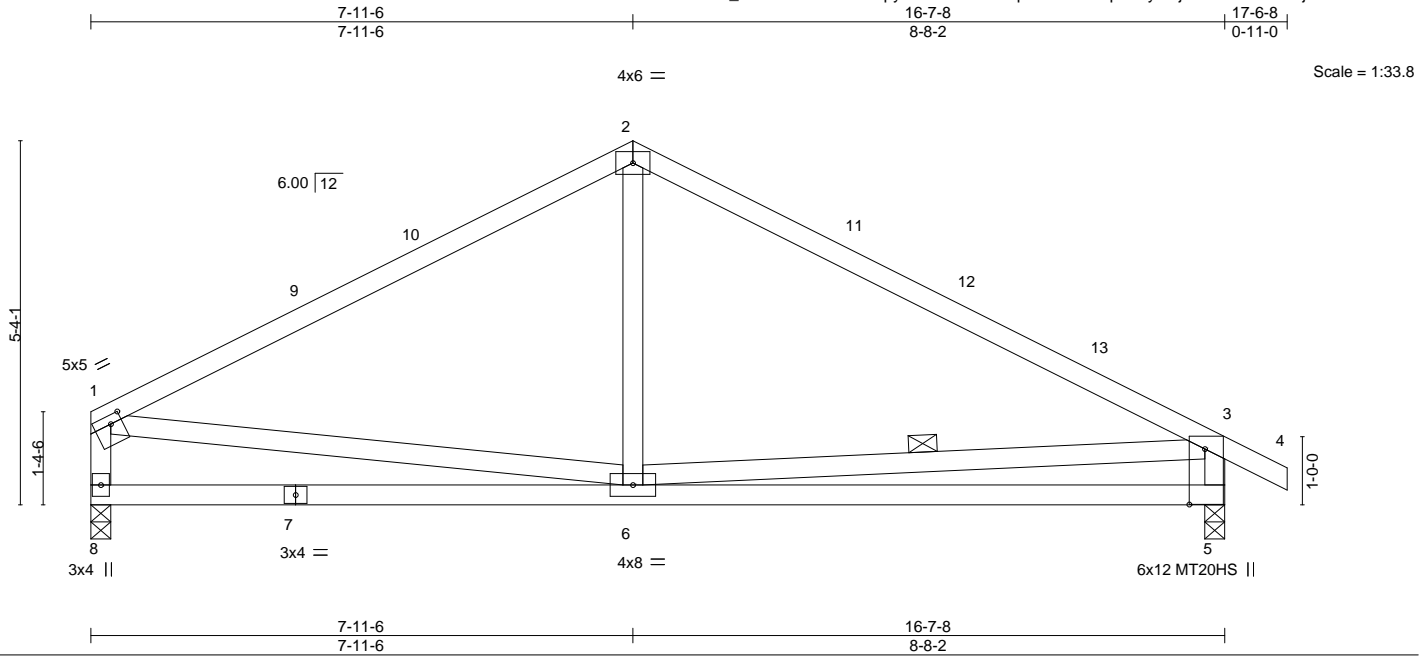

Plate Offsets (X,Y)--	[1:0-2-0,0-1-8], [5:0-9-12,0-2-12]				
LOADING (psf)	SPACING-	CSI.	DEFL.	PLATES	GRIP
TCLL (roof) 20.0	2-0-0	TC 0.87	in (loc) l/defl L/d	MT20	244/190
Snow (Pf/Pg) 15.4/20.0	Plate Grip DOL 1.15	BC 0.64	Vert(LL) -0.11 5-6 >999 240	MT20HS	187/143
TCDL 10.0	Lumber DOL 1.15	WB 0.18	Vert(CT) -0.23 5-6 >851 180		
BCLL 0.0 *	Rep Stress Incr YES	Matrix-MS	Horz(CT) 0.01 5 n/a n/a		
BCDL 10.0	Code IRC2018/TPI2014			Weight: 87 lb	FT = 20%

LUMBER-	BRACING-
TOP CHORD 2x4 SP No.1	TOP CHORD Structural wood sheathing directly applied or 2-2-0 oc purlins, except end verticals.
BOT CHORD 2x4 SP No.2	BOT CHORD Rigid ceiling directly applied or 10-0-0 oc bracing.
WEBS 2x4 SP No.3 *Except* 3-5: 2x4 SP No.2	WEBS 1 Row at midpt 3-6

REACTIONS.	(size) 8=0-3-8, 5=0-3-8
	Max Horz 8=110(LC 14)
	Max Uplift 8=39(LC 16), 5=73(LC 16)
	Max Grav 8=651(LC 2), 5=719(LC 2)

FORCES.	(lb) - Max. Comp./Max. Ten. - All forces 250 (lb) or less except when shown.
TOP CHORD	1-2=-767/181, 2-3=-787/181, 1-8=-584/181, 3-5=-642/236
BOT CHORD	6-8=-82/268, 5-6=-218/600
WEBS	2-6=0/309, 1-6=-2/437, 3-6=-104/260

- NOTES-**
- 1) Unbalanced roof live loads have been considered for this design.
 - 2) Wind: ASCE 7-16; Vult=130mph (3-second gust) Vasd=103mph; TCDL=6.0psf; BCDL=6.0psf; h=25ft; B=45ft; L=24ft; eave=4ft; Cat. II; Exp B; Enclosed; MWFRS (directional) and C-C Exterior(2E) 0-1-12 to 3-1-12, Interior(1) 3-1-12 to 7-11-6, Exterior(2R) 7-11-6 to 10-11-6, Interior(1) 10-11-6 to 17-6-8 zone; cantilever left and right exposed ; end vertical left and right exposed; C-C for members and forces & MWFRS for reactions shown; Lumber DOL=1.60 plate grip DOL=1.60
 - 3) TCLL: ASCE 7-16; Pr=20.0 psf (roof LL: Lum DOL=1.15 Plate DOL=1.15); Pg=20.0 psf; Pf=15.4 psf (Lum DOL = 1.15 Plate DOL = 1.15); Is=1.0; Rough Cat B; Partially Exp.; Ce=1.0; Cs=1.00; Ct=1.10
 - 4) Unbalanced snow loads have been considered for this design.
 - 5) This truss has been designed for greater of min roof live load of 12.0 psf or 1.00 times flat roof load of 15.4 psf on overhangs non-concurrent with other live loads.
 - 6) All plates are MT20 plates unless otherwise indicated.
 - 7) This truss has been designed for a 10.0 psf bottom chord live load nonconcurrent with any other live loads.
 - 8) * This truss has been designed for a live load of 20.0psf on the bottom chord in all areas where a rectangle 3-6-0 tall by 2-0-0 wide will fit between the bottom chord and any other members.
 - 9) Provide mechanical connection (by others) of truss to bearing plate capable of withstanding 100 lb uplift at joint(s) 8, 5.
 - 10) This truss is designed in accordance with the 2018 International Residential Code sections R502.11.1 and R802.10.2 and referenced standard ANSI/TPI 1.



April 10, 2026

Job 26-1922-A	Truss T01A	Truss Type Common	Qty 3	Ply 1	MDP-LOT #16 ROOF	81045321
------------------	---------------	----------------------	----------	----------	------------------	----------

Riverside Roof Truss, LLC, Danville, Va - 24541,

8.830 s Mar 11 2026 MiTek Industries, Inc. Fri Apr 10 06:38:45 2026 Page 1

ID:kk2_eRZGXvKblGikzSpyNzs9fO-XvdvKqh2QmPfrKpS1cyQ6jaE8YcMxLfb?KjwezSCAu

16-4-0
8-4-10

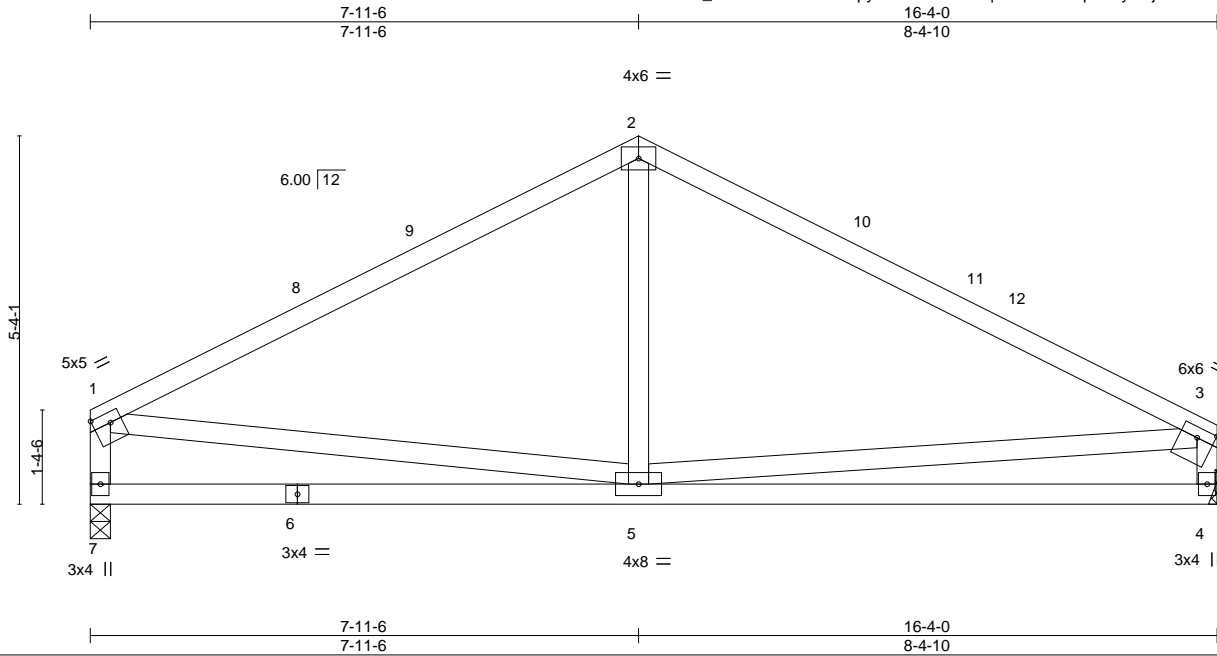

Scale = 1:33.4

Plate Offsets (X,Y)--	[1:Edge,0-1-12], [3:Edge,0-1-12]				
LOADING (psf)	SPACING-	CSI.	DEFL.	PLATES	GRIP
TCLL (roof) 20.0	2-0-0	TC 0.91	in (loc) l/defl L/d	MT20	244/190
Snow (Pf/Pg) 15.4/20.0	Plate Grip DOL 1.15	BC 0.59	Vert(LL) -0.10 4-5 >999 240		
TCDL 10.0	Lumber DOL 1.15	WB 0.18	Vert(CT) -0.20 4-5 >979 180		
BCLL 0.0 *	Rep Stress Incr YES	Matrix-MS	Horz(CT) 0.01 4 n/a n/a		
BCDL 10.0	Code IRC2018/TPI2014			Weight: 84 lb	FT = 20%

LUMBER-	BRACING-
TOP CHORD 2x4 SP No.1	TOP CHORD Structural wood sheathing directly applied or 1-11-14 oc purlins, except end verticals.
BOT CHORD 2x4 SP No.2	BOT CHORD Rigid ceiling directly applied or 10-0-0 oc bracing.
WEBS 2x4 SP No.3	

REACTIONS. (size) 7=0-3-8, 4=Mechanical
 Max Horz 7=-102(LC 14)
 Max Uplift 7=-39(LC 16), 4=-39(LC 16)
 Max Grav 7=642(LC 2), 4=642(LC 2)

FORCES. (lb) - Max. Comp./Max. Ten. - All forces 250 (lb) or less except when shown.
 TOP CHORD 1-2=-751/182, 2-3=-759/181, 1-7=-573/182, 3-4=-567/184
 BOT CHORD 5-7=-119/261, 4-5=-115/328
 WEBS 2-5=0/290, 1-5=-4/426, 3-5=0/361

- NOTES-**
- Unbalanced roof live loads have been considered for this design.
 - Wind: ASCE 7-16; Vult=130mph (3-second gust) Vasd=103mph; TC DL=6.0psf; BCDL=6.0psf; h=25ft; B=45ft; L=24ft; eave=4ft; Cat. II; Exp B; Enclosed; MWFRS (directional) and C-C Exterior(2E) 0-1-12 to 3-1-12, Interior(1) 3-1-12 to 7-11-6, Exterior(2R) 7-11-6 to 10-11-6, Interior(1) 10-11-6 to 16-2-4 zone; cantilever left and right exposed; end vertical left and right exposed; C-C for members and forces & MWFRS for reactions shown; Lumber DOL=1.60 plate grip DOL=1.60
 - TCLL: ASCE 7-16; Pr=20.0 psf (roof LL: Lum DOL=1.15 Plate DOL=1.15); Pg=20.0 psf; Pf=15.4 psf (Lum DOL = 1.15 Plate DOL = 1.15); Is=1.0; Rough Cat B; Partially Exp.; Ce=1.0; Cs=1.00; Ct=1.10
 - Unbalanced snow loads have been considered for this design.
 - This truss has been designed for a 10.0 psf bottom chord live load nonconcurrent with any other live loads.
 - * This truss has been designed for a live load of 20.0psf on the bottom chord in all areas where a rectangle 3-6-0 tall by 2-0-0 wide will fit between the bottom chord and any other members.
 - Refer to girder(s) for truss to truss connections.
 - Provide mechanical connection (by others) of truss to bearing plate capable of withstanding 100 lb uplift at joint(s) 7, 4.
 - This truss is designed in accordance with the 2018 International Residential Code sections R502.11.1 and R802.10.2 and referenced standard ANSI/TPI 1.



April 10, 2026

Job 26-1922-A	Truss T01GE	Truss Type GABLE	Qty 1	Ply 1	MDP-LOT #16 ROOF Job Reference (optional)	I81045322
------------------	----------------	---------------------	----------	----------	--	-----------

Riverside Roof Truss, LLC, Danville, Va - 24541,

8.830 s Mar 11 2026 MiTek Industries, Inc. Fri Apr 10 06:38:46 2026 Page 1

ID:kk2_eRZGXvKblGikzSpyNzs9fO-75AHYAigA4XWSUv?017ByJGyuY1E5QPopf4HT5zSCAT

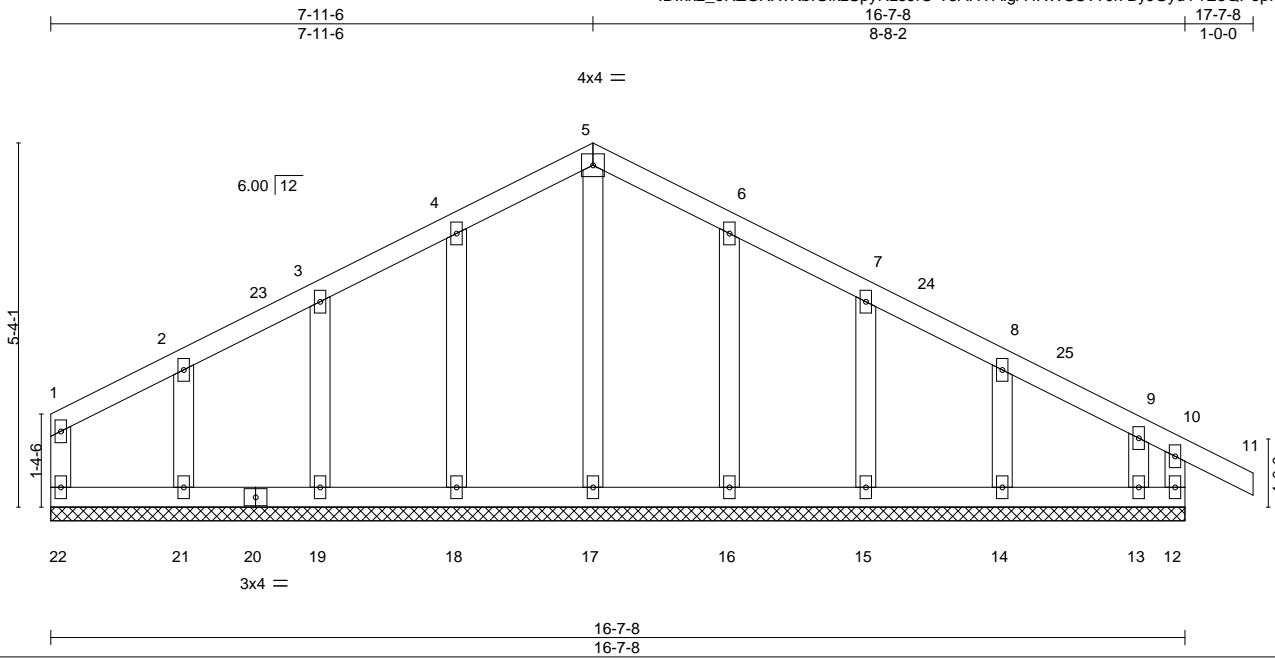

LOADING (psf)	SPACING-	CSI.	DEFL.	PLATES	GRIP
TCLL (roof) 20.0	2-0-0	TC 0.09	in (loc) l/defl L/d	MT20	244/190
Snow (Pf/Pg) 15.4/20.0	Plate Grip DOL 1.15	BC 0.05	Vert(LL) -0.00 11 n/r 120		
TCDL 10.0	Lumber DOL 1.15	WB 0.06	Vert(CT) -0.00 11 n/r 120		
BCLL 0.0 *	Rep Stress Incr YES	Matrix-R	Horz(CT) 0.00 12 n/a n/a		
BCDL 10.0	Code IRC2018/TPI2014			Weight: 90 lb	FT = 20%

LUMBER-	BRACING-
TOP CHORD 2x4 SP No.2	TOP CHORD Structural wood sheathing directly applied or 6-0-0 oc purlins, except end verticals.
BOT CHORD 2x4 SP No.2	BOT CHORD Rigid ceiling directly applied or 10-0-0 oc bracing.
WEBS 2x4 SP No.3	
OTHERS 2x4 SP No.3	

REACTIONS. All bearings 16-7-8.
 (lb) - Max Horz 22=111(LC 14)
 Max Uplift All uplift 100 lb or less at joint(s) 22, 12, 18, 19, 21, 16, 15, 14, 13
 Max Grav All reactions 250 lb or less at joint(s) 22, 12, 17, 18, 19, 21, 16, 15, 14, 13

FORCES. (lb) - Max. Comp./Max. Ten. - All forces 250 (lb) or less except when shown.

- NOTES-**
- Unbalanced roof live loads have been considered for this design.
 - Wind: ASCE 7-16; Vult=130mph (3-second gust) Vasd=103mph; TCCL=6.0psf; BCDL=6.0psf; h=25ft; B=45ft; L=24ft; eave=2ft; Cat. II; Exp B; Enclosed; MWFRS (directional) and C-C Corner(3E) 0-1-12 to 3-1-12, Exterior(2N) 3-1-12 to 7-11-6, Corner(3R) 7-11-6 to 10-11-6, Exterior(2N) 10-11-6 to 17-7-8 zone; cantilever left and right exposed; end vertical left and right exposed; C-C for members and forces & MWFRS for reactions shown; Lumber DOL=1.60 plate grip DOL=1.60
 - Truss designed for wind loads in the plane of the truss only. For studs exposed to wind (normal to the face), see Standard Industry Gable End Details as applicable, or consult qualified building designer as per ANSI/TPI 1.
 - TCLL: ASCE 7-16; Pr=20.0 psf (roof LL: Lum DOL=1.15 Plate DOL=1.15); Pg=20.0 psf; Pf=15.4 psf (Lum DOL = 1.15 Plate DOL = 1.15); Is=1.0; Rough Cat B; Partially Exp.; Ce=1.0; Cs=1.00; Ct=1.10
 - Unbalanced snow loads have been considered for this design.
 - This truss has been designed for greater of min roof live load of 12.0 psf or 1.00 times flat roof load of 15.4 psf on overhangs non-concurrent with other live loads.
 - All plates are 2x4 MT20 unless otherwise indicated.
 - Gable requires continuous bottom chord bearing.
 - Truss to be fully sheathed from one face or securely braced against lateral movement (i.e. diagonal web).
 - Gable studs spaced at 2-0-0 oc.
 - This truss has been designed for a 10.0 psf bottom chord live load nonconcurrent with any other live loads.
 - * This truss has been designed for a live load of 20.0psf on the bottom chord in all areas where a rectangle 3-6-0 tall by 2-0-0 wide will fit between the bottom chord and any other members.
 - Provide mechanical connection (by others) of truss to bearing plate capable of withstanding 100 lb uplift at joint(s) 22, 12, 18, 19, 21, 16, 15, 14, 13.
 - This truss is designed in accordance with the 2018 International Residential Code sections R502.11.1 and R802.10.2 and referenced standard ANSI/TPI 1.



April 10, 2026

Job 26-1922-A	Truss T02	Truss Type Common	Qty 3	Ply 1	MDP-LOT #16 ROOF Job Reference (optional)	I81045323
------------------	--------------	----------------------	----------	----------	--	-----------

Riverside Roof Truss, LLC, Danville, Va - 24541,

8.830 s Mar 11 2026 MiTek Industries, Inc. Fri Apr 10 06:38:46 2026 Page 1

ID:kk2_eRZGXXvKblGikzSpyNzs9fO-?5AHYAigA4XWSUv?0I7ByJGrSYu65DYopf4HT5zSCat



Scale = 1:47.4

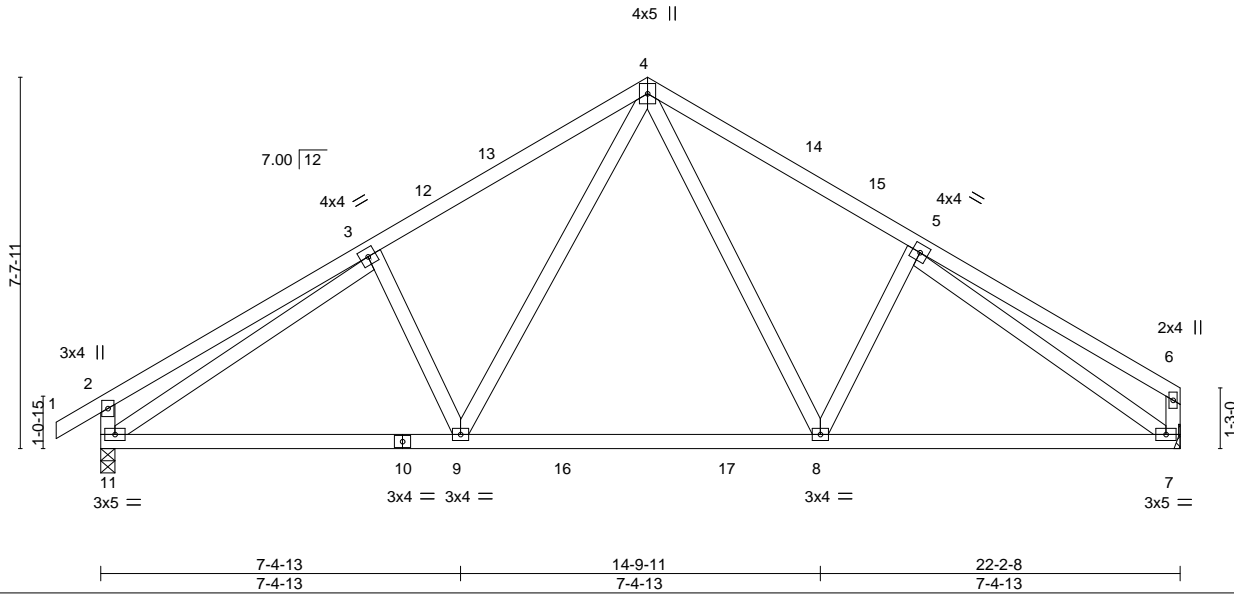

Job 26-1922-A	Truss T02G	Truss Type Common Girder	Qty 1	Ply 2	MDP-LOT #16 ROOF	181045324
------------------	---------------	-----------------------------	----------	----------	------------------	-----------

Riverside Roof Truss, LLC, Danville, Va - 24541,

8.830 s Mar 11 2026 MiTek Industries, Inc. Fri Apr 10 06:38:47 2026 Page 1
ID:kk2_eRZGXxvKblGikzSpyNzs9fO-THkflWjixOfN4eUBZSfQVXo0QyBZqeZy2Jpq?XzSCAs

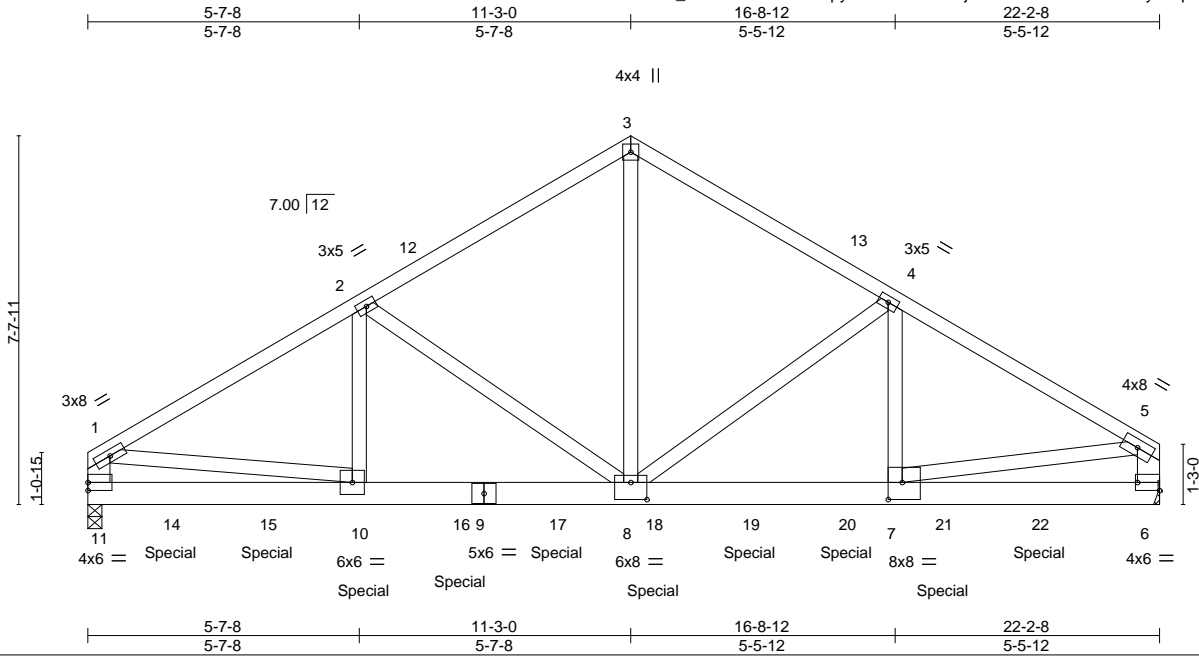

Scale: 1/4"=1'

Plate Offsets (X,Y)--	[6:Edge,0-2-0], [7:0-3-8,0-4-4], [8:0-4-0,0-4-4]				
LOADING (psf)	SPACING-	CSI.	DEFL.	PLATES	GRIP
TCLL (roof) 20.0	2-0-0	TC 0.55	in (loc) l/defl L/d	MT20	244/190
Snow (Pf/Pg) 15.4/20.0	Plate Grip DOL 1.15	BC 0.75	Vert(LL) -0.10 7-8 >999 240		
TCDL 10.0	Lumber DOL 1.15	WB 0.96	Vert(CT) -0.18 7-8 >999 180		
BCLL 0.0 *	Rep Stress Incr NO	Matrix-MS	Horz(CT) 0.03 6 n/a n/a		
BCDL 10.0	Code IRC2018/TPI2014			Weight: 297 lb	FT = 20%

LUMBER-	BRACING-
TOP CHORD 2x4 SP No.2	TOP CHORD Structural wood sheathing directly applied or 4-9-6 oc purlins, except end verticals.
BOT CHORD 2x6 SP No.2 *Except* 6-9: 2x6 SP 2400F 2.0E	BOT CHORD Rigid ceiling directly applied or 10-0-0 oc bracing.
WEBS 2x4 SP No.3 *Except* 1-11,5-6: 2x6 SP No.2	

REACTIONS. (size) 11=0-3-8, 6=Mechanical
 Max Horz 11=157(LC 36)
 Max Uplift 11=80(LC 12)
 Max Grav 11=4264(LC 2), 6=5820(LC 3)

FORCES. (lb) - Max. Comp./Max. Ten. - All forces 250 (lb) or less except when shown.
 TOP CHORD 1-2=-5672/96, 2-3=-4594/0, 3-4=-4590/0, 4-5=-6339/0, 1-11=-3559/76, 5-6=-4155/0
 BOT CHORD 10-11=-91/942, 8-10=-10/4839, 7-8=0/5414, 6-7=0/845
 WEBS 2-10=-222/1240, 2-8=-1485/327, 3-8=0/4277, 4-8=-1901/0, 4-7=0/1780, 1-10=0/3996,
 5-7=0/4649

- NOTES-**
- 2-ply truss to be connected together with 10d (0.131"x3") nails as follows:
 Top chords connected as follows: 2x4 - 1 row at 0-9-0 oc, 2x6 - 2 rows staggered at 0-9-0 oc.
 Bottom chords connected as follows: 2x6 - 2 rows staggered at 0-9-0 oc.
 Webs connected as follows: 2x4 - 1 row at 0-9-0 oc.
 - All loads are considered equally applied to all plies, except if noted as front (F) or back (B) face in the LOAD CASE(S) section. Ply to ply connections have been provided to distribute only loads noted as (F) or (B), unless otherwise indicated.
 - Unbalanced roof live loads have been considered for this design.
 - Wind: ASCE 7-16; Vult=130mph (3-second gust) Vasd=103mph; TCDL=6.0psf; BCDL=6.0psf; h=25ft; B=45ft; L=24ft; eave=4ft; Cat. II; Exp B; Enclosed; MWFRS (directional); cantilever left and right exposed; end vertical left and right exposed; Lumber DOL=1.60 plate grip DOL=1.60
 - TCLL: ASCE 7-16; Pr=20.0 psf (roof LL: Lum DOL=1.15 Plate DOL=1.15); Pg=20.0 psf; Pf=15.4 psf (Lum DOL = 1.15 Plate DOL = 1.15); Is=1.0; Rough Cat B; Partially Exp.; Ce=1.0; Cs=1.00; Ct=1.10
 - Unbalanced snow loads have been considered for this design.
 - This truss has been designed for a 10.0 psf bottom chord live load nonconcurrent with any other live loads.
 - * This truss has been designed for a live load of 20.0psf on the bottom chord in all areas where a rectangle 3-6-0 tall by 2-0-0 wide will fit between the bottom chord and any other members.
 - Refer to girder(s) for truss to truss connections.
 - Provide mechanical connection (by others) of truss to bearing plate capable of withstanding 100 lb uplift at joint(s) 11.
 - This truss is designed in accordance with the 2018 International Residential Code sections R502.11.1 and R802.10.2 and referenced standard ANSI/TPI 1.



April 10, 2026

Continued on page 2

<p>WARNING - Verify design parameters and READ NOTES ON THIS AND INCLUDED MITEK REFERENCE PAGE MII-7473 rev. 1/2/2023 BEFORE USE. Design valid for use only with MiTek® connectors. This design is based only upon parameters shown, and is for an individual building component, not a truss system. Before use, the building designer must verify the applicability of design parameters and properly incorporate this design into the overall building design. Bracing indicated is to prevent buckling of individual truss web and/or chord members only. Additional temporary and permanent bracing is always required for stability and to prevent collapse with possible personal injury and property damage. For general guidance regarding the fabrication, storage, delivery, erection and bracing of trusses and truss systems, see ANSI/TP1 Quality Criteria and DSB-22 available from Truss Plate Institute (www.tpinst.org) and BCSI Building Component Safety Information available from the Structural Building Component Association (www.sbcacomponents.com)</p>	<p>ENGINEERING BY TRENCO A MITTEK Affiliate</p> <p>818 Soundside Road Edenton, NC 27932</p>
--	---

Job 26-1922-A	Truss T02G	Truss Type Common Girder	Qty 1	Ply 2	MDP-LOT #16 ROOF Job Reference (optional)	I81045324
------------------	---------------	-----------------------------	----------	-----------------	--	-----------

Riverside Roof Truss, LLC, Danville, Va - 24541,

8.830 s Mar 11 2026 MiTek Industries, Inc. Fri Apr 10 06:38:47 2026 Page 2
ID:kk2_eRZGXXvKblGikzSpyNzs9fO-THkflWjlxOfN4eUBZSfQVXo0QyBZqeZy2Jpq?XzSCAs

NOTES-

12) Hanger(s) or other connection device(s) shall be provided sufficient to support concentrated load(s) 622 lb down and 59 lb up at 1-8-12, 622 lb down and 59 lb up at 3-8-12, 622 lb down and 59 lb up at 5-8-12, 719 lb down and 121 lb up at 7-8-12, 699 lb down and 112 lb up at 9-8-12, 947 lb down and 33 lb up at 11-8-12, 944 lb down at 13-8-12, 944 lb down at 15-8-12, 944 lb down at 17-8-12, and 944 lb down at 19-8-12, and 951 lb down at 21-11-12 on bottom chord. The design/selection of such connection device(s) is the responsibility of others.

LOAD CASE(S) Standard

1) Dead + Snow (balanced): Lumber Increase=1.15, Plate Increase=1.15

Uniform Loads (plf)

Vert: 1-3=-51, 3-5=-51, 6-11=-20

Concentrated Loads (lb)

Vert: 10=-592(F) 6=-696(F) 14=-592(F) 15=-592(F) 16=-719(F) 17=-640(F) 18=-748(F) 19=-689(F) 20=-689(F) 21=-689(F) 22=-689(F)

WARNING - Verify design parameters and READ NOTES ON THIS AND INCLUDED MITEK REFERENCE PAGE MII-7473 rev. 1/2/2023 BEFORE USE.

Design valid for use only with MiTek® connectors. This design is based only upon parameters shown, and is for an individual building component, not a truss system. Before use, the building designer must verify the applicability of design parameters and properly incorporate this design into the overall building design. Bracing indicated is to prevent buckling of individual truss web and/or chord members only. Additional temporary and permanent bracing is always required for stability and to prevent collapse with possible personal injury and property damage. For general guidance regarding the fabrication, storage, delivery, erection and bracing of trusses and truss systems, see **ANSI/TPH Quality Criteria and DSB-22** available from Truss Plate Institute (www.tpinst.org) and **BCSI Building Component Safety Information** available from the Structural Building Component Association (www.sbcacomponents.com)



818 Soundside Road
Edenton, NC 27932

Job	Truss	Truss Type	Qty	Ply	MDP-LOT #16 ROOF	181045325
26-1922-A	T02GE	GABLE	1	1		
Riverside Roof Truss, LLC, Danville, Va - 24541,						Job Reference (optional)

8.830 s Mar 11 2026 MiTek Industries, Inc. Fri Apr 10 06:38:48 2026 Page 1

ID:wNbLyI9Ve8oavxOPg0PWn6zSCEh-yUI1zrkwhnEio2O7AAf1kLlglLijZKE5HzZNxzzSCAR



Scale = 1:37.4

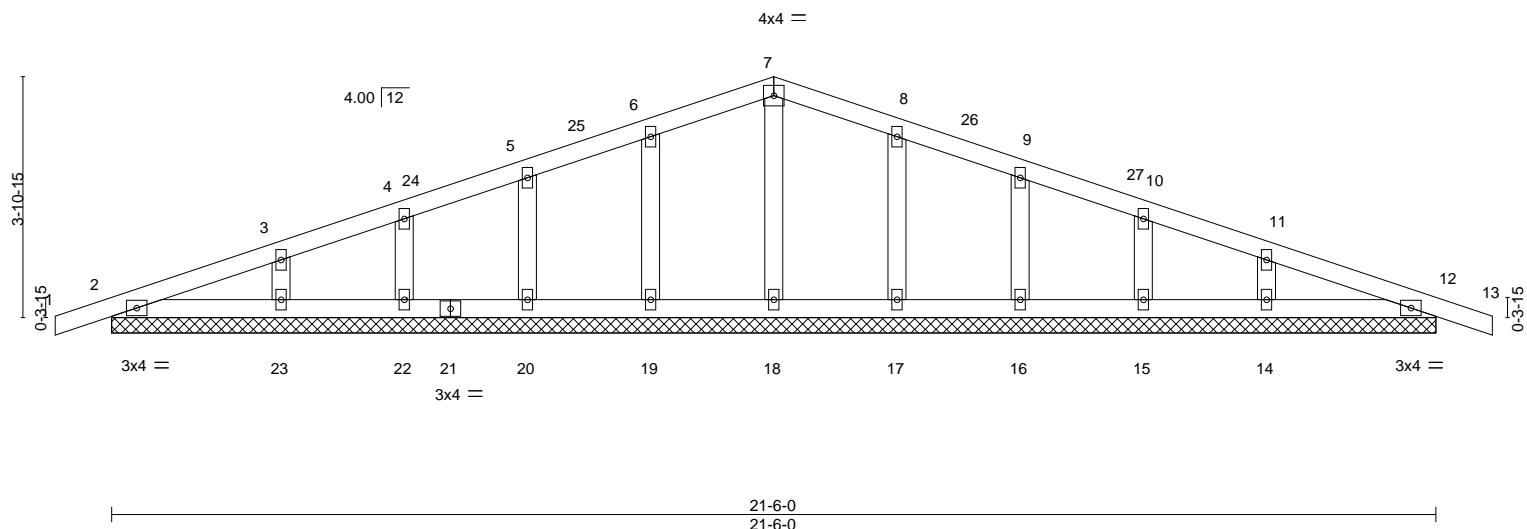

LOADING (psf)	SPACING-	CSI.	DEFL.	PLATES	GRIP
TCLL (roof) 20.0	2-0-0	TC 0.07	in (loc) l/defl L/d	MT20	244/190
Snow (Pf/Pg) 15.4/20.0	Plate Grip DOL 1.15	BC 0.05	Vert(LL) 0.00 12 n/r 120		
TCDL 10.0	Lumber DOL 1.15	WB 0.04	Vert(CT) 0.00 13 n/r 120		
BCLL 0.0 *	Rep Stress Incr YES	Matrix-S	Horz(CT) 0.00 12 n/a n/a		
BCDL 10.0	Code IRC2018/TPI2014			Weight: 94 lb	FT = 20%

LUMBER-	BRACING-
TOP CHORD 2x4 SP No.2	TOP CHORD Structural wood sheathing directly applied or 6-0-0 oc purlins.
BOT CHORD 2x4 SP No.2	BOT CHORD Rigid ceiling directly applied or 10-0-0 oc bracing.
OTHERS 2x4 SP No.3	

REACTIONS. All bearings 21-6-0.
 (lb) - Max Horz 2=41(LC 15)
 Max Uplift All uplift 100 lb or less at joint(s) 2, 19, 20, 22, 23, 17, 16, 15, 14, 12
 Max Grav All reactions 250 lb or less at joint(s) 2, 18, 19, 20, 22, 23, 17, 16, 15, 14, 12

FORCES. (lb) - Max. Comp./Max. Ten. - All forces 250 (lb) or less except when shown.

- NOTES-**
- 1) Unbalanced roof live loads have been considered for this design.
 - 2) Wind: ASCE 7-16; Vult=130mph (3-second gust) Vasd=103mph; TCCL=6.0psf; BCDL=6.0psf; h=25ft; B=45ft; L=24ft; eave=2ft; Cat. II; Exp B; Enclosed; MWFRS (directional) and C-C Corner(3E) -0-11-0 to 2-1-0, Exterior(2N) 2-1-0 to 10-9-0, Corner(3R) 10-9-0 to 13-9-0, Exterior(2N) 13-9-0 to 22-5-0 zone; cantilever left and right exposed; end vertical left and right exposed; C-C for members and forces & MWFRS for reactions shown; Lumber DOL=1.60 plate grip DOL=1.60
 - 3) Truss designed for wind loads in the plane of the truss only. For studs exposed to wind (normal to the face), see Standard Industry Gable End Details as applicable, or consult qualified building designer as per ANSI/TPI 1.
 - 4) TCLL: ASCE 7-16; Pr=20.0 psf (roof LL: Lum DOL=1.15 Plate DOL=1.15); Pg=20.0 psf; Pf=15.4 psf (Lum DOL = 1.15 Plate DOL = 1.15); Is=1.0; Rough Cat B; Partially Exp.; Ce=1.0; Cs=1.00; Ct=1.10
 - 5) Unbalanced snow loads have been considered for this design.
 - 6) This truss has been designed for greater of min roof live load of 12.0 psf or 1.00 times flat roof load of 15.4 psf on overhangs non-concurrent with other live loads.
 - 7) All plates are 2x4 MT20 unless otherwise indicated.
 - 8) Gable requires continuous bottom chord bearing.
 - 9) Gable studs spaced at 2-0-0 oc.
 - 10) This truss has been designed for a 10.0 psf bottom chord live load nonconcurrent with any other live loads.
 - 11) * This truss has been designed for a live load of 20.0psf on the bottom chord in all areas where a rectangle 3-6-0 tall by 2-0-0 wide will fit between the bottom chord and any other members.
 - 12) Provide mechanical connection (by others) of truss to bearing plate capable of withstanding 100 lb uplift at joint(s) 2, 19, 20, 22, 23, 17, 16, 15, 14, 12.
 - 13) This truss is designed in accordance with the 2018 International Residential Code sections R502.11.1 and R802.10.2 and referenced standard ANSI/TPI 1.



April 10, 2026

Job 26-1922-A	Truss T02SGE	Truss Type GABLE	Qty 1	Ply 1	MDP-LOT #16 ROOF	181045326
------------------	-----------------	---------------------	----------	----------	------------------	-----------

Riverside Roof Truss, LLC,

Danville, Va - 24541,

8.830 s Mar 11 2026 MiTek Industries, Inc. Fri Apr 10 06:38:49 2026 Page 1

ID:kk2_eRZGXXvKblGikzSpyNzs9fO-QgsPABkZT?v5JxdahthuayuNlnxclhbEVdlx3QzSCAq

Job Reference (optional)



Scale = 1:53.8

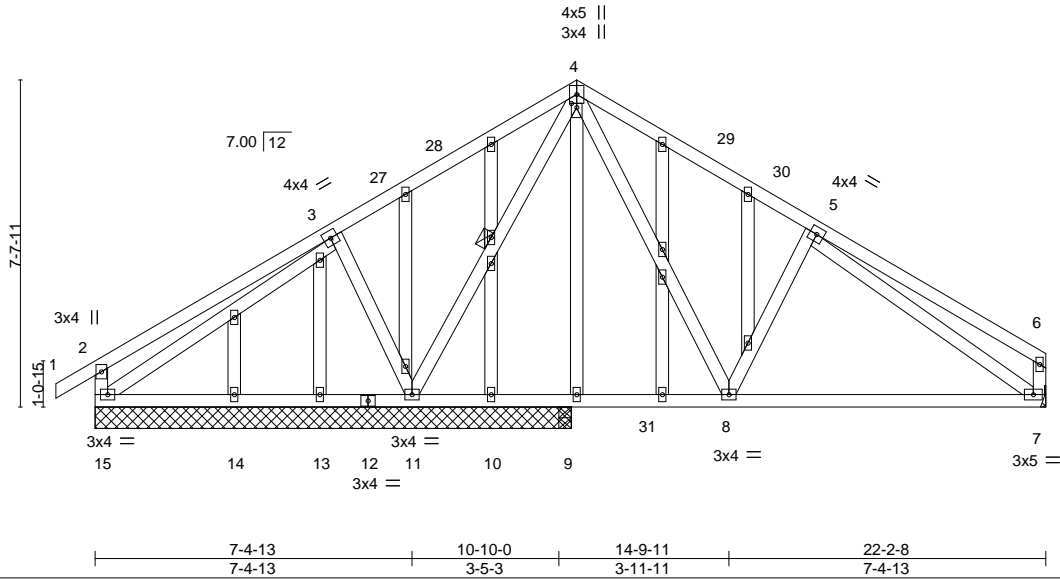

Plate Offsets (X,Y)-- [4:0-1-2,0-1-8]					
LOADING (psf)	SPACING-	CSI.	DEFL.	PLATES	GRIP
TCLL (roof) 20.0	2-0-0	TC 0.50	in (loc) l/defl L/d	MT20	244/190
Snow (Pf/Pg) 15.4/20.0	Plate Grip DOL 1.15	BC 0.46	Vert(LL) -0.07 7-8 >999 240		
TCDL 10.0	Lumber DOL 1.15	WB 0.42	Vert(CT) -0.15 7-8 >875 180		
BCLL 0.0 *	Rep Stress Incr YES	Matrix-MS	Horz(CT) 0.01 7 n/a n/a		
BCDL 10.0	Code IRC2018/TPI2014			Weight: 178 lb	FT = 20%

LUMBER-	BRACING-
TOP CHORD 2x4 SP No.2	TOP CHORD Structural wood sheathing directly applied or 6-0-0 oc purlins, except end verticals.
BOT CHORD 2x4 SP No.2	BOT CHORD Rigid ceiling directly applied or 10-0-0 oc bracing.
WEBS 2x4 SP No.3	WEBS 1 Row at midpt 4-11
OTHERS 2x4 SP No.3	

REACTIONS. All bearings 11-1-8 except (jt=length) 7=Mechanical.
 (lb) - Max Horz 15=169(LC 15)
 Max Uplift All uplift 100 lb or less at joint(s) 15, 7 except 11=126(LC 16)
 Max Grav All reactions 250 lb or less at joint(s) 9, 9, 10, 13, 14 except 11=828(LC 28), 15=296(LC 34), 7=621(LC 29)

FORCES. (lb) - Max. Comp./Max. Ten. - All forces 250 (lb) or less except when shown.
 TOP CHORD 4-5=-576/148, 2-15=-259/125
 BOT CHORD 7-8=-48/495
 WEBS 3-11=-333/159, 4-11=-550/44, 4-8=-49/515, 5-8=-263/144, 5-7=-495/48

- NOTES-**
- 1) Unbalanced roof live loads have been considered for this design.
 - 2) Wind: ASCE 7-16; Vult=130mph (3-second gust) Vasd=103mph; TCDL=6.0psf; BCDL=6.0psf; h=25ft; B=45ft; L=24ft; eave=4ft; Cat. II; Exp B; Enclosed; MWFRS (directional) and C-C Exterior(2E) -0-11-0 to 2-1-0, Interior(1) 2-1-0 to 11-3-0, Exterior(2R) 11-3-0 to 14-3-0, Interior(1) 14-3-0 to 22-0-12 zone; cantilever left and right exposed; end vertical left and right exposed; C-C for members and forces & MWFRS for reactions shown; Lumber DOL=1.60 plate grip DOL=1.60
 - 3) Truss designed for wind loads in the plane of the truss only. For studs exposed to wind (normal to the face), see Standard Industry Gable End Details as applicable, or consult qualified building designer as per ANSI/TPI 1.
 - 4) TCLL: ASCE 7-16; Pr=20.0 psf (roof LL: Lum DOL=1.15 Plate DOL=1.15); Pg=20.0 psf; Pf=15.4 psf (Lum DOL = 1.15 Plate DOL = 1.15); Is=1.0; Rough Cat B; Partially Exp.; Ce=1.0; Cs=1.00; Ct=1.10
 - 5) Unbalanced snow loads have been considered for this design.
 - 6) This truss has been designed for greater of min roof live load of 12.0 psf or 1.00 times flat roof load of 15.4 psf on overhangs non-concurrent with other live loads.
 - 7) All plates are 2x4 MT20 unless otherwise indicated.
 - 8) Gable studs spaced at 2-0-0 oc.
 - 9) This truss has been designed for a 10.0 psf bottom chord live load nonconcurrent with any other live loads.
 - 10) * This truss has been designed for a live load of 20.0psf on the bottom chord in all areas where a rectangle 3-6-0 tall by 2-0-0 wide will fit between the bottom chord and any other members, with BCDL = 10.0psf.
 - 11) Refer to girder(s) for truss to truss connections.
 - 12) Provide mechanical connection (by others) of truss to bearing plate capable of withstanding 100 lb uplift at joint(s) 15, 7 except (jt=lb) 11=126.
 - 13) This truss is designed in accordance with the 2018 International Residential Code sections R502.11.1 and R802.10.2 and referenced standard ANSI/TPI 1.



April 10, 2026

Job 26-1922-A	Truss T03	Truss Type Common	Qty 1	Ply 1	MDP-LOT #16 ROOF	81045327
------------------	--------------	----------------------	----------	----------	------------------	----------

Riverside Roof Truss, LLC, Danville, Va - 24541,

8.830 s Mar 11 2026 MiTek Industries, Inc. Fri Apr 10 06:38:49 2026 Page 1

ID:kk2_eRZGXvKblGikzSpyNzs9fO-QgsPABkZT?v5JxdahthuayuKXI_FlmeEVdix3QzSCAq

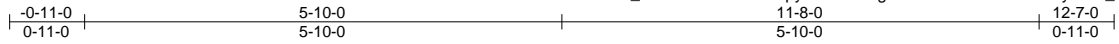

Scale = 1:28.2

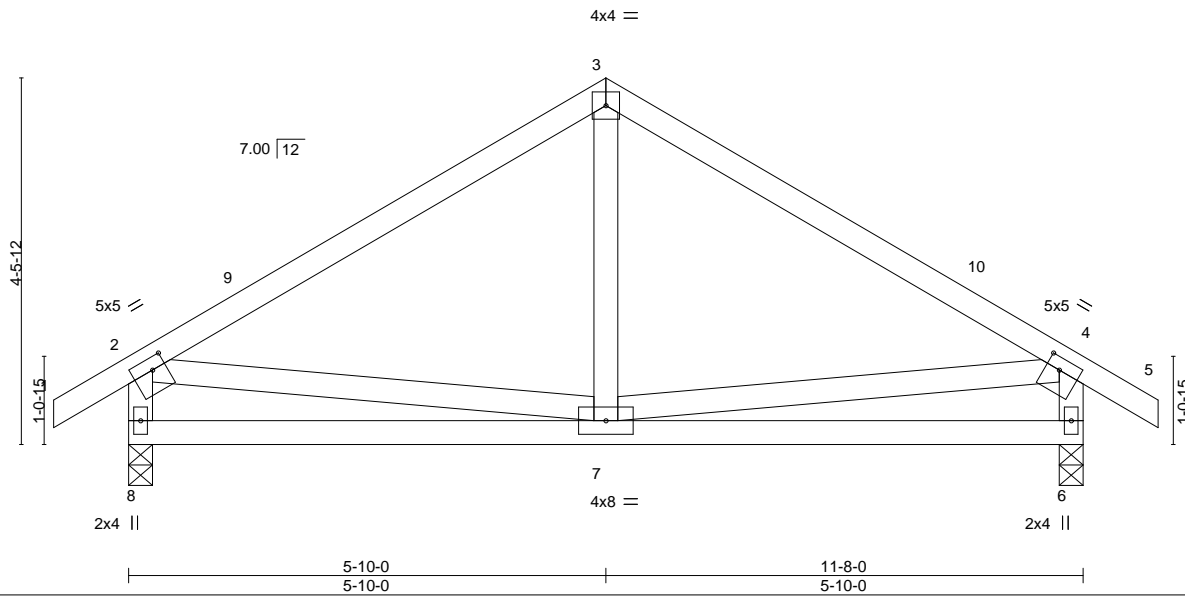

Plate Offsets (X,Y)-- [2:0-2-0,0-1-12], [4:0-2-0,0-1-12]

LOADING (psf)	SPACING-	CSI.	DEFL.	PLATES	GRIP
TCLL (roof) 20.0	2-0-0	TC 0.70	in (loc) l/defl L/d	MT20	244/190
Snow (Pf/Pg) 15.4/20.0	Plate Grip DOL 1.15	BC 0.29	Vert(LL) -0.02 6-7 >999 240		
TCDL 10.0	Lumber DOL 1.15	WB 0.09	Vert(CT) -0.05 6-7 >999 180		
BCLL 0.0 *	Rep Stress Incr YES	Matrix-MS	Horz(CT) 0.00 6 n/a n/a		
BCDL 10.0	Code IRC2018/TPI2014			Weight: 65 lb	FT = 20%

LUMBER-
TOP CHORD 2x4 SP No.2
BOT CHORD 2x4 SP No.2
WEBS 2x4 SP No.3

BRACING-
TOP CHORD Structural wood sheathing directly applied or 6-0-0 oc purlins, except end verticals.
BOT CHORD Rigid ceiling directly applied or 10-0-0 oc bracing.

REACTIONS. (size) 8=0-3-8, 6=0-3-8
Max Horz 8=-106(LC 14)
Max Uplift 8=-61(LC 16), 6=-61(LC 16)
Max Grav 8=520(LC 21), 6=520(LC 22)

FORCES. (lb) - Max. Comp./Max. Ten. - All forces 250 (lb) or less except when shown.
TOP CHORD 2-3=-485/108, 3-4=-485/108, 2-8=-468/163, 4-6=-469/164
BOT CHORD 7-8=-107/267, 6-7=-80/259

- NOTES-**
- 1) Unbalanced roof live loads have been considered for this design.
 - 2) Wind: ASCE 7-16; Vult=130mph (3-second gust) Vasd=103mph; TCCL=6.0psf; BCDL=6.0psf; h=25ft; B=45ft; L=24ft; eave=4ft; Cat. II; Exp B; Enclosed; MWFRS (directional) and C-C Exterior(2E) -0-11-0 to 2-1-0, Interior(1) 2-1-0 to 5-10-0, Exterior(2R) 5-10-0 to 8-10-0, Interior(1) 8-10-0 to 12-7-0 zone; cantilever left and right exposed; end vertical left and right exposed; C-C for members and forces & MWFRS for reactions shown; Lumber DOL=1.60 plate grip DOL=1.60
 - 3) TCLL: ASCE 7-16; Pr=20.0 psf (roof LL: Lum DOL=1.15 Plate DOL=1.15); Pg=20.0 psf; Pf=15.4 psf (Lum DOL = 1.15 Plate DOL = 1.15); Is=1.0; Rough Cat B; Partially Exp.; Ce=1.0; Cs=1.00; Ct=1.10
 - 4) Unbalanced snow loads have been considered for this design.
 - 5) This truss has been designed for greater of min roof live load of 12.0 psf or 1.00 times flat roof load of 15.4 psf on overhangs non-concurrent with other live loads.
 - 6) This truss has been designed for a 10.0 psf bottom chord live load nonconcurrent with any other live loads.
 - 7) * This truss has been designed for a live load of 20.0psf on the bottom chord in all areas where a rectangle 3-6-0 tall by 2-0-0 wide will fit between the bottom chord and any other members.
 - 8) Provide mechanical connection (by others) of truss to bearing plate capable of withstanding 100 lb uplift at joint(s) 8, 6.
 - 9) This truss is designed in accordance with the 2018 International Residential Code sections R502.11.1 and R802.10.2 and referenced standard ANSI/TPI 1.



April 10, 2026

WARNING - Verify design parameters and READ NOTES ON THIS AND INCLUDED MITEK REFERENCE PAGE MII-7473 rev. 1/2/2023 BEFORE USE.
Design valid for use only with MiTek® connectors. This design is based only upon parameters shown, and is for an individual building component, not a truss system. Before use, the building designer must verify the applicability of design parameters and properly incorporate this design into the overall building design. Bracing indicated is to prevent buckling of individual truss web and/or chord members only. Additional temporary and permanent bracing is always required for stability and to prevent collapse with possible personal injury and property damage. For general guidance regarding the fabrication, storage, delivery, erection and bracing of trusses and truss systems, see **ANSI/TPH Quality Criteria and DSB-22** available from Truss Plate Institute (www.tpinst.org) and **BCSI Building Component Safety Information** available from the Structural Building Component Association (www.sbcacomponents.com)



818 Soundside Road
Edenton, NC 27932

Job	Truss	Truss Type	Qty	Ply	MDP-LOT #16 ROOF	81045328
26-1922-A	T03GE	GABLE	1	1	Job Reference (optional)	

Riverside Roof Truss, LLC, Danville, Va - 24541,

8.830 s Mar 11 2026 MiTek Industries, Inc. Fri Apr 10 06:38:50 2026 Page 1

ID:kk2_eRZGXvKblGikzSpyNzs9fO-usQoOXIBEJ1yx5CmFbc769Qe29Oa1DdOkH2UcszSCAp

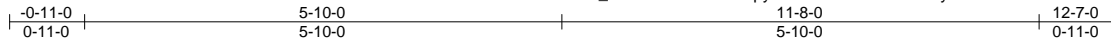

Scale = 1:28.2

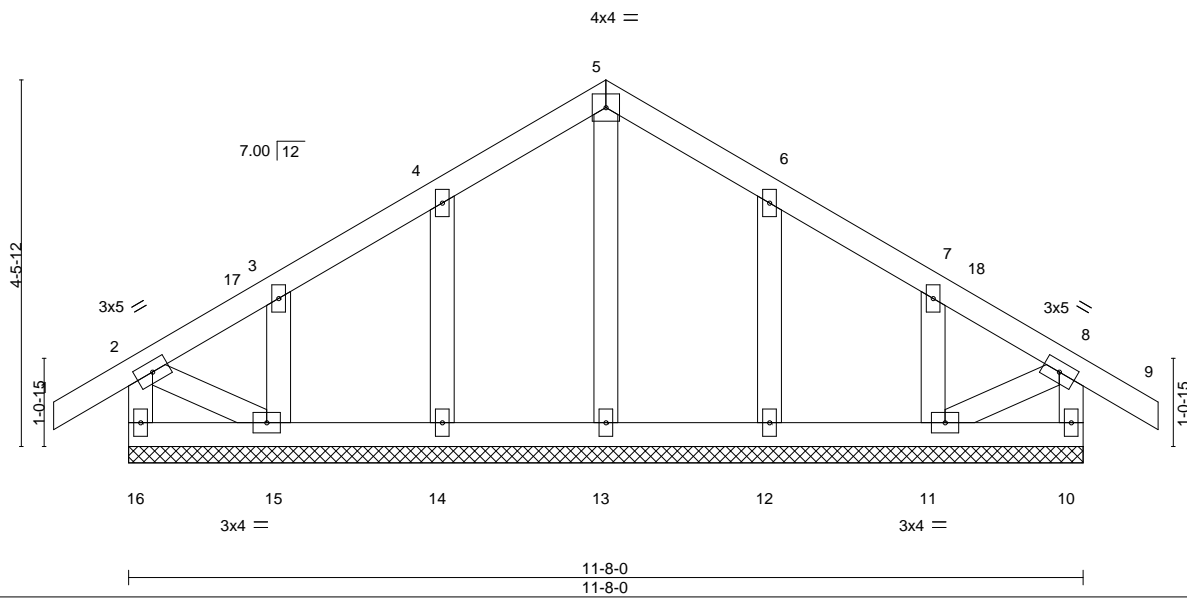

LOADING (psf)	SPACING-	CSI.	DEFL.	PLATES	GRIP
TCLL (roof) 20.0	2-0-0	TC 0.08	in (loc) l/defl L/d	MT20	244/190
Snow (Pf/Pg) 15.4/20.0	Plate Grip DOL 1.15	BC 0.03	Vert(LL) -0.00 9 n/r 120		
TCDL 10.0	Lumber DOL 1.15	WB 0.05	Vert(CT) -0.00 9 n/r 120		
BCLL 0.0 *	Rep Stress Incr YES	Matrix-S	Horz(CT) 0.00 10 n/a n/a		
BCDL 10.0	Code IRC2018/TPI2014			Weight: 66 lb	FT = 20%

LUMBER-	BRACING-
TOP CHORD 2x4 SP No.2	TOP CHORD Structural wood sheathing directly applied or 6-0-0 oc purlins, except end verticals.
BOT CHORD 2x4 SP No.2	BOT CHORD Rigid ceiling directly applied or 6-0-0 oc bracing.
WEBS 2x4 SP No.3	
OTHERS 2x4 SP No.3	

REACTIONS. All bearings 11-8-0.
 (lb) - Max Horz 16=106(LC 14)
 Max Uplift All uplift 100 lb or less at joint(s) 16, 10, 14, 15, 12, 11
 Max Grav All reactions 250 lb or less at joint(s) 16, 10, 13, 14, 15, 12, 11

FORCES. (lb) - Max. Comp./Max. Ten. - All forces 250 (lb) or less except when shown.

- NOTES-**
- 1) Unbalanced roof live loads have been considered for this design.
 - 2) Wind: ASCE 7-16; Vult=130mph (3-second gust) Vasd=103mph; TC DL=6.0psf; BCDL=6.0psf; h=25ft; B=45ft; L=24ft; eave=2ft; Cat. II; Exp B; Enclosed; MWFRS (directional) and C-C Corner(3E) -0-11-0 to 1-10-0, Exterior(2N) 1-10-0 to 5-10-0, Corner(3R) 5-10-0 to 8-10-0, Exterior(2N) 8-10-0 to 12-7-0 zone; cantilever left and right exposed; end vertical left and right exposed; C-C for members and forces & MWFRS for reactions shown; Lumber DOL=1.60 plate grip DOL=1.60
 - 3) Truss designed for wind loads in the plane of the truss only. For studs exposed to wind (normal to the face), see Standard Industry Gable End Details as applicable, or consult qualified building designer as per ANSI/TPI 1.
 - 4) TCLL: ASCE 7-16; Pr=20.0 psf (roof LL: Lum DOL=1.15 Plate DOL=1.15); Pg=20.0 psf; Pf=15.4 psf (Lum DOL = 1.15 Plate DOL = 1.15); Is=1.0; Rough Cat B; Partially Exp.; Ce=1.0; Cs=1.00; Ct=1.10
 - 5) Unbalanced snow loads have been considered for this design.
 - 6) This truss has been designed for greater of min roof live load of 12.0 psf or 1.00 times flat roof load of 15.4 psf on overhangs non-concurrent with other live loads.
 - 7) All plates are 2x4 MT20 unless otherwise indicated.
 - 8) Gable requires continuous bottom chord bearing.
 - 9) Truss to be fully sheathed from one face or securely braced against lateral movement (i.e. diagonal web).
 - 10) Gable studs spaced at 2-0-0 oc.
 - 11) This truss has been designed for a 10.0 psf bottom chord live load nonconcurrent with any other live loads.
 - 12) * This truss has been designed for a live load of 20.0psf on the bottom chord in all areas where a rectangle 3-6-0 tall by 2-0-0 wide will fit between the bottom chord and any other members.
 - 13) Provide mechanical connection (by others) of truss to bearing plate capable of withstanding 100 lb uplift at joint(s) 16, 10, 14, 15, 12, 11.
 - 14) This truss is designed in accordance with the 2018 International Residential Code sections R502.11.1 and R802.10.2 and referenced standard ANSI/TPI 1.



April 10, 2026

Job 26-1922-A	Truss T04	Truss Type Common	Qty 3	Ply 1	MDP-LOT #16 ROOF	I81045329
------------------	--------------	----------------------	----------	----------	------------------	-----------

Riverside Roof Truss, LLC, Danville, Va - 24541,

8.830 s Mar 11 2026 MiTek Industries, Inc. Fri Apr 10 06:38:51 2026 Page 1
ID:kk2_eRZGXvKbIGikzSpyNzs9fO-M3_Abtmp?cApZFnzoljMfNzfsZY5mbjXzxn28lzSCAo

Job Reference (optional)

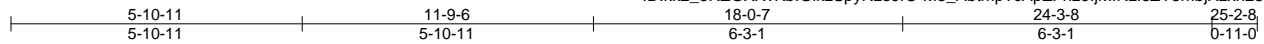

4x4 =

Scale = 1:46.6

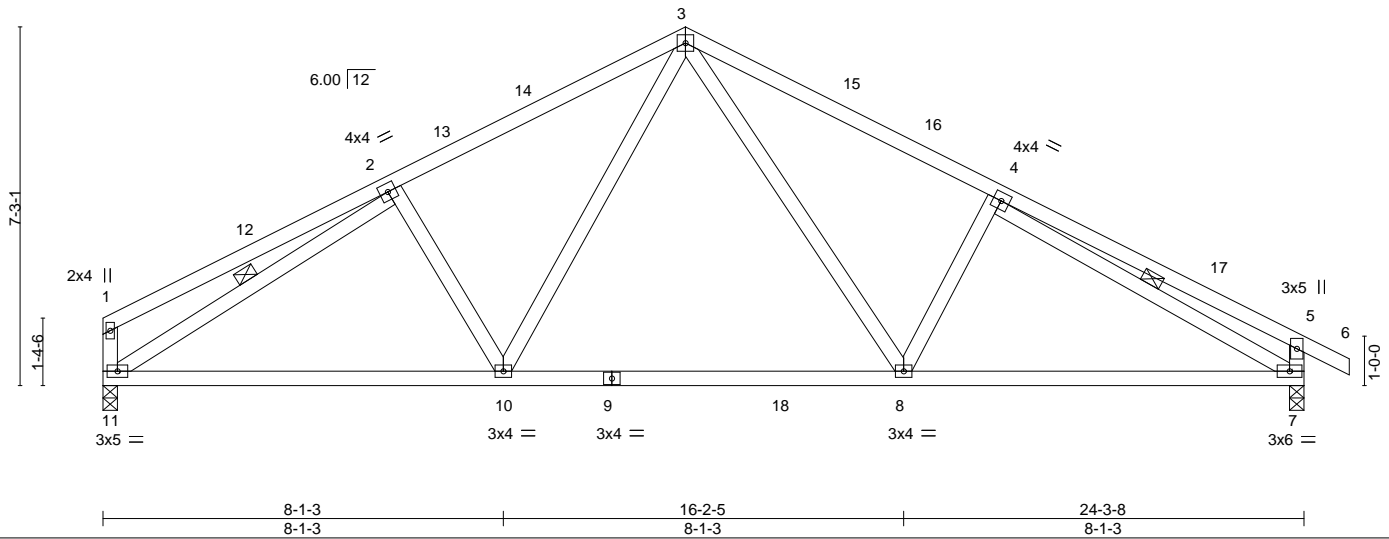

LOADING (psf)	SPACING-	CSI.	DEFL.	PLATES	GRIP
TCLL (roof) 20.0	2-0-0	TC 0.71	in (loc) l/defl L/d	MT20	244/190
Snow (Pf/Pg) 15.4/20.0	Plate Grip DOL 1.15	BC 0.78	Vert(LL) -0.15 8-10 >999 240		
TCDL 10.0	Lumber DOL 1.15	WB 0.38	Vert(CT) -0.23 8-10 >999 180		
BCLL 0.0 *	Rep Stress Incr YES	Matrix-MS	Horz(CT) 0.04 7 n/a n/a		
BCDL 10.0	Code IRC2018/TPI2014			Weight: 136 lb	FT = 20%

LUMBER-	BRACING-
TOP CHORD 2x4 SP No.2	TOP CHORD Structural wood sheathing directly applied or 3-7-0 oc purlins, except end verticals.
BOT CHORD 2x4 SP No.2	BOT CHORD Rigid ceiling directly applied or 10-0-0 oc bracing.
WEBS 2x4 SP No.3	WEBS 1 Row at midpt 2-11, 4-7

REACTIONS.	(size) 11=0-3-8, 7=0-3-8
	Max Horz 11=-142(LC 14)
	Max Uplift 11=-58(LC 16), 7=-92(LC 16)
	Max Grav 11=1054(LC 28), 7=1115(LC 29)

FORCES.	(lb) - Max. Comp./Max. Ten. - All forces 250 (lb) or less except when shown.
TOP CHORD	2-3=-1344/233, 3-4=-1444/246, 4-5=-428/119, 5-7=-377/149
BOT CHORD	10-11=-111/1262, 8-10=-16/952, 7-8=-112/1312
WEBS	3-10=-36/507, 3-8=-58/609, 4-8=-274/170, 2-11=-1271/157, 4-7=-1188/111

- NOTES-**
- 1) Unbalanced roof live loads have been considered for this design.
 - 2) Wind: ASCE 7-16; Vult=130mph (3-second gust) Vasd=103mph; TCCL=6.0psf; BCDL=6.0psf; h=25ft; B=45ft; L=24ft; eave=4ft; Cat. II; Exp B; Enclosed; MWFRS (directional) and C-C Exterior(2E) 0-1-12 to 3-1-12, Interior(1) 3-1-12 to 11-9-6, Exterior(2R) 11-9-6 to 14-9-6, Interior(1) 14-9-6 to 25-2-8 zone; cantilever left and right exposed; end vertical left and right exposed; C-C for members and forces & MWFRS for reactions shown; Lumber DOL=1.60 plate grip DOL=1.60
 - 3) TCLL: ASCE 7-16; Pr=20.0 psf (roof LL: Lum DOL=1.15 Plate DOL=1.15); Pg=20.0 psf; Pf=15.4 psf (Lum DOL = 1.15 Plate DOL = 1.15); Is=1.0; Rough Cat B; Partially Exp.; Ce=1.0; Cs=1.00; Ct=1.10
 - 4) Unbalanced snow loads have been considered for this design.
 - 5) This truss has been designed for greater of min roof live load of 12.0 psf or 1.00 times flat roof load of 15.4 psf on overhangs non-concurrent with other live loads.
 - 6) This truss has been designed for a 10.0 psf bottom chord live load nonconcurrent with any other live loads.
 - 7) * This truss has been designed for a live load of 20.0psf on the bottom chord in all areas where a rectangle 3-6-0 tall by 2-0-0 wide will fit between the bottom chord and any other members, with BCDL = 10.0psf.
 - 8) Provide mechanical connection (by others) of truss to bearing plate capable of withstanding 100 lb uplift at joint(s) 11, 7.
 - 9) This truss is designed in accordance with the 2018 International Residential Code sections R502.11.1 and R802.10.2 and referenced standard ANSI/TPI 1.



April 10, 2026

Job 26-1922-A	Truss T04G	Truss Type Common Girder	Qty 1	Ply 2	MDP-LOT #16 ROOF Job Reference (optional)	181045330
------------------	---------------	-----------------------------	----------	-----------------	--	-----------

Riverside Roof Truss, LLC, Danville, Va - 24541,

8.830 s Mar 11 2026 MiTek Industries, Inc. Fri Apr 10 06:38:52 2026 Page 2
ID:kk2_eRZGXxvKblGikzSpyNzs9fO-qFYyoDnRmwlgAPM9M0EbCaWsrzzVVv1hCaXbgIzSCAn

NOTES-

- 12) Use Simpson Strong-Tie HUS26 (14-10d Girder, 4-10d Truss) or equivalent at 22-2-12 from the left end to connect truss(es) to back face of bottom chord.
- 13) Fill all nail holes where hanger is in contact with lumber.

LOAD CASE(S) Standard

- 1) Dead + Snow (balanced): Lumber Increase=1.15, Plate Increase=1.15
- Uniform Loads (plf)
 - Vert: 1-4=-51, 4-8=-51, 15-16=-20
- Concentrated Loads (lb)
 - Vert: 10=-4764(B) 9=-776(B) 16=-522(B) 21=-776(B) 22=-776(B)

WARNING - Verify design parameters and READ NOTES ON THIS AND INCLUDED MITEK REFERENCE PAGE MII-7473 rev. 1/2/2023 BEFORE USE.

Design valid for use only with MiTek® connectors. This design is based only upon parameters shown, and is for an individual building component, not a truss system. Before use, the building designer must verify the applicability of design parameters and properly incorporate this design into the overall building design. Bracing indicated is to prevent buckling of individual truss web and/or chord members only. Additional temporary and permanent bracing is always required for stability and to prevent collapse with possible personal injury and property damage. For general guidance regarding the fabrication, storage, delivery, erection and bracing of trusses and truss systems, see **ANSI/TP1 Quality Criteria and DSB-22** available from Truss Plate Institute (www.tpinst.org) and **BCSI Building Component Safety Information** available from the Structural Building Component Association (www.sbcacomponents.com)



818 Soundside Road
Edenton, NC 27932

Job 26-1922-A	Truss T04GE	Truss Type GABLE	Qty 1	Ply 1	MDP-LOT #16 ROOF	181045331
------------------	----------------	---------------------	----------	----------	------------------	-----------

Riverside Roof Truss, LLC, Danville, Va - 24541,

8.830 s Mar 11 2026 MiTek Industries, Inc. Fri Apr 10 06:38:52 2026 Page 1

ID:kk2_eRZGXxvKblGikzSpyNzs9fO-qFYyDnRmwlgAPM9M0EbCaW_2z4oV5ihCaXbglzSCAn



4x4 =

Scale = 1:46.6

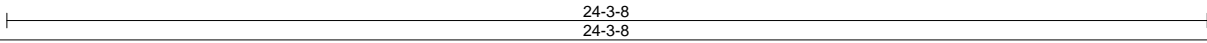
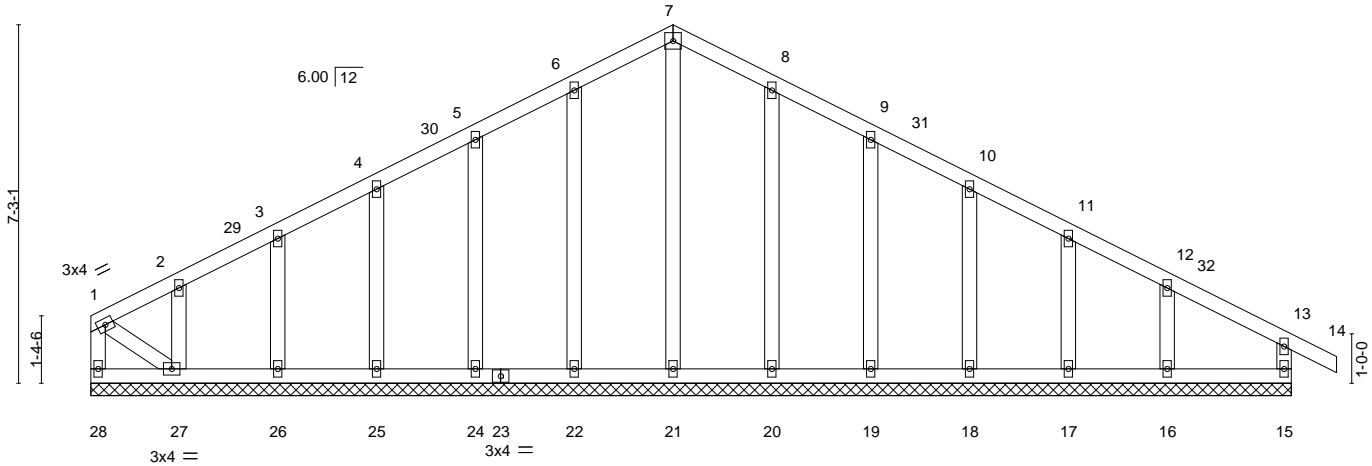

LOADING (psf)	SPACING-	CSI.	DEFL.	in (loc)	l/defl	L/d	PLATES	GRIP
TCLL (roof) 20.0	2-0-0	TC 0.11	Vert(LL) -0.00	14	n/r	120	MT20	244/190
Snow (Pf/Pg) 15.4/20.0	Plate Grip DOL 1.15	BC 0.04	Vert(CT) -0.00	14	n/r	120		
TCDL 10.0	Lumber DOL 1.15	WB 0.14	Horz(CT) 0.00	15	n/a	n/a		
BCLL 0.0 *	Rep Stress Incr YES	Matrix-S					Weight: 148 lb	FT = 20%
BCDL 10.0	Code IRC2018/TPI2014							

LUMBER-
TOP CHORD 2x4 SP No.2
BOT CHORD 2x4 SP No.2
WEBS 2x4 SP No.3
OTHERS 2x4 SP No.3

BRACING-
TOP CHORD Structural wood sheathing directly applied or 6-0-0 oc purlins, except end verticals.
BOT CHORD Rigid ceiling directly applied or 6-0-0 oc bracing, Except: 10-0-0 oc bracing: 27-28.

REACTIONS. All bearings 24-3-8.
(lb) - Max Horz 28=142(LC 14)
Max Uplift All uplift 100 lb or less at joint(s) 28, 15, 22, 24, 25, 26, 27, 20, 19, 18, 17, 16
Max Grav All reactions 250 lb or less at joint(s) 28, 15, 21, 22, 24, 25, 26, 27, 20, 19, 18, 17, 16

FORCES. (lb) - Max. Comp./Max. Ten. - All forces 250 (lb) or less except when shown.

NOTES-

- Unbalanced roof live loads have been considered for this design.
- Wind: ASCE 7-16; Vult=130mph (3-second gust) Vasd=103mph; TCCL=6.0psf; BCDL=6.0psf; h=25ft; B=45ft; L=24ft; eave=2ft; Cat. II; Exp B; Enclosed; MWFRS (directional) and C-C Corner(3E) 0-1-12 to 3-1-12, Exterior(2N) 3-1-12 to 11-9-6, Corner(3R) 11-9-6 to 14-9-6, Exterior(2N) 14-9-6 to 25-2-8 zone; cantilever left and right exposed; end vertical left and right exposed; C-C for members and forces & MWFRS for reactions shown; Lumber DOL=1.60 plate grip DOL=1.60
- Truss designed for wind loads in the plane of the truss only. For studs exposed to wind (normal to the face), see Standard Industry Gable End Details as applicable, or consult qualified building designer as per ANSI/TPI 1.
- TCLL: ASCE 7-16; Pr=20.0 psf (roof LL: Lum DOL=1.15 Plate DOL=1.15); Pg=20.0 psf; Pf=15.4 psf (Lum DOL = 1.15 Plate DOL = 1.15); Is=1.0; Rough Cat B; Partially Exp.; Ce=1.0; Cs=1.00; Ct=1.10
- Unbalanced snow loads have been considered for this design.
- This truss has been designed for greater of min roof live load of 12.0 psf or 1.00 times flat roof load of 15.4 psf on overhangs non-concurrent with other live loads.
- All plates are 2x4 MT20 unless otherwise indicated.
- Gable requires continuous bottom chord bearing.
- Truss to be fully sheathed from one face or securely braced against lateral movement (i.e. diagonal web).
- Gable studs spaced at 2-0-0 oc.
- This truss has been designed for a 10.0 psf bottom chord live load nonconcurrent with any other live loads.
- * This truss has been designed for a live load of 20.0psf on the bottom chord in all areas where a rectangle 3-6-0 tall by 2-0-0 wide will fit between the bottom chord and any other members.
- Provide mechanical connection (by others) of truss to bearing plate capable of withstanding 100 lb uplift at joint(s) 28, 15, 22, 24, 25, 26, 27, 20, 19, 18, 17, 16.
- This truss is designed in accordance with the 2018 International Residential Code sections R502.11.1 and R802.10.2 and referenced standard ANSI/TPI 1.



April 10, 2026

WARNING - Verify design parameters and READ NOTES ON THIS AND INCLUDED MITEK REFERENCE PAGE MII-7473 rev. 1/2/2023 BEFORE USE.

Design valid for use only with MiTek® connectors. This design is based only upon parameters shown, and is for an individual building component, not a truss system. Before use, the building designer must verify the applicability of design parameters and properly incorporate this design into the overall building design. Bracing indicated is to prevent buckling of individual truss web and/or chord members only. Additional temporary and permanent bracing is always required for stability and to prevent collapse with possible personal injury and property damage. For general guidance regarding the fabrication, storage, delivery, erection and bracing of trusses and truss systems, see **ANSI/TP1 Quality Criteria and DSB-22** available from Truss Plate Institute (www.tpinst.org) and **BCSI Building Component Safety Information** available from the Structural Building Component Association (www.sbcacomponents.com)



818 Soundside Road
Edenton, NC 27932

Job 26-1922-A	Truss T05	Truss Type Common	Qty 3	Ply 1	MDP-LOT #16 ROOF	181045332
------------------	--------------	----------------------	----------	----------	------------------	-----------

Riverside Roof Truss, LLC, Danville, Va - 24541,

8.830 s Mar 11 2026 MiTek Industries, Inc. Fri Apr 10 06:38:53 2026 Page 1

ID:kk2_eRZGXxvKblGikzSpyNzs9fO-IR6w0Zn3XEQxoZxLwjlqko2_iMMuEZOqQEG8CBzSCAm

Job Reference (optional)



4x4 =

Scale = 1:26.1

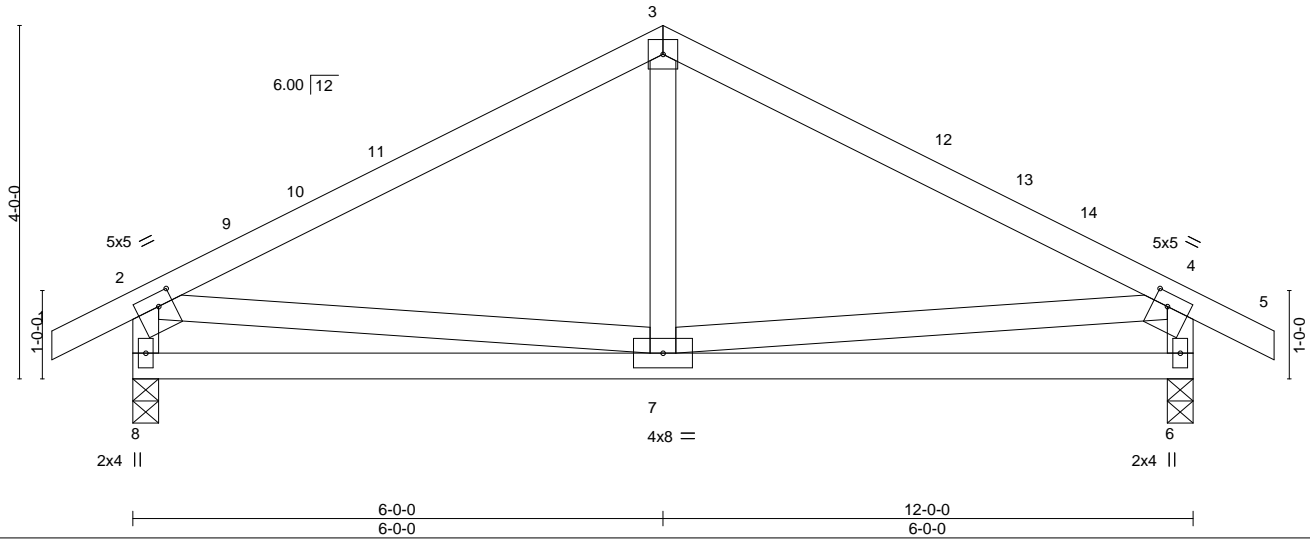

Plate Offsets (X,Y)-- [2:0-2-0,0-1-12], [4:0-2-0,0-1-12]

LOADING (psf)	SPACING-	CSI.	DEFL.	PLATES	GRIP
TCLL (roof) 20.0	2-0-0	TC 0.76	in (loc) l/defl L/d	MT20	244/190
Snow (Pf/Pg) 15.4/20.0	Plate Grip DOL 1.15	BC 0.31	Vert(LL) -0.02 6-7 >999 240		
TCDL 10.0	Lumber DOL 1.15	WB 0.11	Vert(CT) -0.05 6-7 >999 180		
BCLL 0.0 *	Rep Stress Incr YES	Matrix-MS	Horz(CT) 0.00 6 n/a n/a		
BCDL 10.0	Code IRC2018/TPI2014			Weight: 64 lb	FT = 20%

LUMBER-
 TOP CHORD 2x4 SP No.2
 BOT CHORD 2x4 SP No.2
 WEBS 2x4 SP No.3

BRACING-
 TOP CHORD Structural wood sheathing directly applied or 6-0-0 oc purlins, except end verticals.
 BOT CHORD Rigid ceiling directly applied or 10-0-0 oc bracing.

REACTIONS. (size) 8=0-3-8, 6=0-3-8
 Max Horz 8=82(LC 15)
 Max Uplift 8=62(LC 16), 6=62(LC 16)
 Max Grav 8=532(LC 2), 6=532(LC 2)

FORCES. (lb) - Max. Comp./Max. Ten. - All forces 250 (lb) or less except when shown.
 TOP CHORD 2-3=-538/177, 3-4=-538/177, 2-8=-479/229, 4-6=-479/229
 BOT CHORD 7-8=-169/307, 6-7=-124/307
 WEBS 2-7=0/262, 4-7=0/262

- NOTES-**
- Unbalanced roof live loads have been considered for this design.
 - Wind: ASCE 7-16; Vult=130mph (3-second gust) Vasd=103mph; TCCL=6.0psf; BCDL=6.0psf; h=25ft; B=45ft; L=24ft; eave=4ft; Cat. II; Exp B; Enclosed; MWFRS (directional) and C-C Exterior(2E) -0-11-0 to 2-1-0, Interior(1) 2-1-0 to 6-0-0, Exterior(2R) 6-0-0 to 9-0-0, Interior(1) 9-0-0 to 12-11-0 zone; cantilever left and right exposed; end vertical left and right exposed; C-C for members and forces & MWFRS for reactions shown; Lumber DOL=1.60 plate grip DOL=1.60
 - TCLL: ASCE 7-16; Pr=20.0 psf (roof LL: Lum DOL=1.15 Plate DOL=1.15); Pg=20.0 psf; Pf=15.4 psf (Lum DOL = 1.15 Plate DOL = 1.15); Is=1.0; Rough Cat B; Partially Exp.; Ce=1.0; Cs=1.00; Ct=1.10
 - Unbalanced snow loads have been considered for this design.
 - This truss has been designed for greater of min roof live load of 12.0 psf or 1.00 times flat roof load of 15.4 psf on overhangs non-concurrent with other live loads.
 - This truss has been designed for a 10.0 psf bottom chord live load nonconcurrent with any other live loads.
 - * This truss has been designed for a live load of 20.0psf on the bottom chord in all areas where a rectangle 3-6-0 tall by 2-0-0 wide will fit between the bottom chord and any other members.
 - Provide mechanical connection (by others) of truss to bearing plate capable of withstanding 100 lb uplift at joint(s) 8, 6.
 - This truss is designed in accordance with the 2018 International Residential Code sections R502.11.1 and R802.10.2 and referenced standard ANSI/TPI 1.



April 10, 2026

WARNING - Verify design parameters and READ NOTES ON THIS AND INCLUDED MITEK REFERENCE PAGE MII-7473 rev. 1/2/2023 BEFORE USE.
 Design valid for use only with MiTek® connectors. This design is based only upon parameters shown, and is for an individual building component, not a truss system. Before use, the building designer must verify the applicability of design parameters and properly incorporate this design into the overall building design. Bracing indicated is to prevent buckling of individual truss web and/or chord members only. Additional temporary and permanent bracing is always required for stability and to prevent collapse with possible personal injury and property damage. For general guidance regarding the fabrication, storage, delivery, erection and bracing of trusses and truss systems, see **ANSI/TP1 Quality Criteria and DSB-22** available from Truss Plate Institute (www.tpinst.org) and **BCSI Building Component Safety Information** available from the Structural Building Component Association (www.sbcacomponents.com)



818 Soundside Road
 Edenton, NC 27932

Job 26-1922-A	Truss T06	Truss Type Common	Qty 5	Ply 1	MDP-LOT #16 ROOF	I81045333
------------------	--------------	----------------------	----------	----------	------------------	-----------

Riverside Roof Truss, LLC,

Danville, Va - 24541,

8.830 s Mar 11 2026 MiTek Industries, Inc. Fri Apr 10 06:38:53 2026 Page 1

ID:kk2_eRZGXXvKblGikzSpyNzs9fO-IR6w0Zn3XEQXoZxLwjlqko2xdMDDEUKqQEG8CBzSCAm

Job Reference (optional)

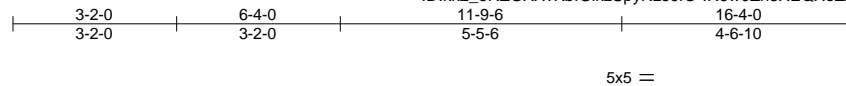

Scale = 1:44.6

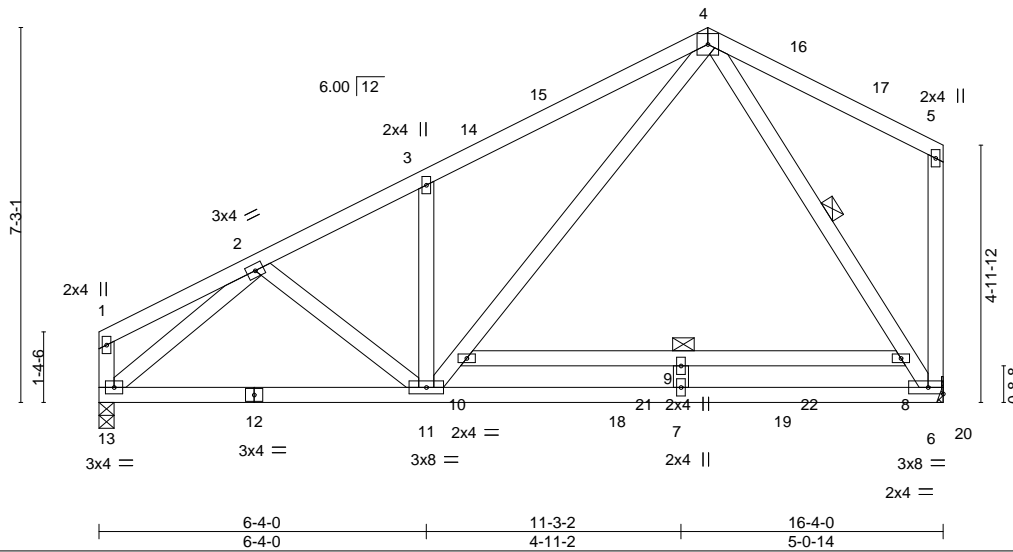

LOADING (psf)	SPACING-	CSI.	DEFL.	PLATES	GRIP
TCLL (roof) 20.0	2-0-0	TC 0.95	in (loc) l/defl L/d	MT20	244/190
Snow (Pf/Pg) 15.4/20.0	Plate Grip DOL 1.15	BC 0.86	Vert(LL) -0.41 6-7 >470 240		
TCDL 10.0	Lumber DOL 1.15	WB 0.43	Vert(CT) -0.68 6-7 >284 180		
BCLL 0.0 *	Rep Stress Incr YES	Matrix-MS	Horz(CT) 0.01 6 n/a n/a		
BCDL 10.0	Code IRC2018/TPI2014			Weight: 115 lb	FT = 20%

LUMBER-
TOP CHORD 2x4 SP No.2
BOT CHORD 2x4 SP No.1 *Except*
12-13: 2x4 SP No.2
WEBS 2x4 SP No.3

BRACING-
TOP CHORD Structural wood sheathing directly applied or 5-0-6 oc purlins, except end verticals.
BOT CHORD Rigid ceiling directly applied or 10-0-0 oc bracing. Except:
6-0-0 oc bracing: 8-10
WEBS 1 Row at midpt 4-6

REACTIONS. (size) 13=0-3-8, 6=Mechanical
Max Horz 13=199(LC 15)
Max Uplift 13=-3(LC 16)
Max Grav 13=818(LC 27), 6=976(LC 27)

FORCES. (lb) - Max. Comp./Max. Ten. - All forces 250 (lb) or less except when shown.
TOP CHORD 2-3=-1042/124, 3-4=-1097/232
BOT CHORD 11-13=-288/853, 7-11=-128/490, 6-7=-128/490
WEBS 3-11=-332/194, 10-11=-150/763, 4-10=-91/949, 2-13=-988/103, 4-8=-609/209, 6-8=-798/150

NOTES-

- 1) Unbalanced roof live loads have been considered for this design.
- 2) Wind: ASCE 7-16; Vult=130mph (3-second gust) Vasd=103mph; TCDL=6.0psf; BCDL=6.0psf; h=25ft; B=45ft; L=24ft; eave=4ft; Cat. II; Exp B; Enclosed; MWFRS (directional) and C-C Exterior(2E) 0-1-12 to 3-0-7, Interior(1) 3-0-7 to 11-9-6, Exterior(2R) 11-9-6 to 14-9-6, Interior(1) 14-9-6 to 16-2-4 zone; cantilever left and right exposed ; end vertical left and right exposed; C-C for members and forces & MWFRS for reactions shown; Lumber DOL=1.60 plate grip DOL=1.60
- 3) TCLL: ASCE 7-16; Pr=20.0 psf (roof LL: Lum DOL=1.15 Plate DOL=1.15); Pg=20.0 psf; Pf=15.4 psf (Lum DOL = 1.15 Plate DOL = 1.15); Is=1.0; Rough Cat B; Partially Exp.; Ce=1.0; Cs=1.00; Ct=1.10
- 4) Unbalanced snow loads have been considered for this design.
- 5) This truss has been designed for a 10.0 psf bottom chord live load nonconcurrent with any other live loads.
- 6) * This truss has been designed for a live load of 20.0psf on the bottom chord in all areas where a rectangle 3-6-0 tall by 2-0-0 wide will fit between the bottom chord and any other members, with BCDL = 10.0psf.
- 7) Refer to girder(s) for truss to truss connections.
- 8) Provide mechanical connection (by others) of truss to bearing plate capable of withstanding 100 lb uplift at joint(s) 13.
- 9) This truss is designed in accordance with the 2018 International Residential Code sections R502.11.1 and R802.10.2 and referenced standard ANSI/TPI 1.



April 10, 2026

Job 26-1922-A	Truss T07	Truss Type Common	Qty 5	Ply 1	MDP-LOT #16 ROOF	181045334
------------------	--------------	----------------------	----------	----------	------------------	-----------

Riverside Roof Truss, LLC, Danville, Va - 24541,

8.830 s Mar 11 2026 MiTek Industries, Inc. Fri Apr 10 06:38:54 2026 Page 1

ID:wNbLyl9Ve8oavxOPg0PWn6zSCEh-mefIDvohIXYOjWYUQH3H7bC0mbXz_R_fu0ildzSCAI

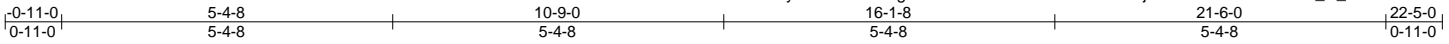

Scale = 1:37.4

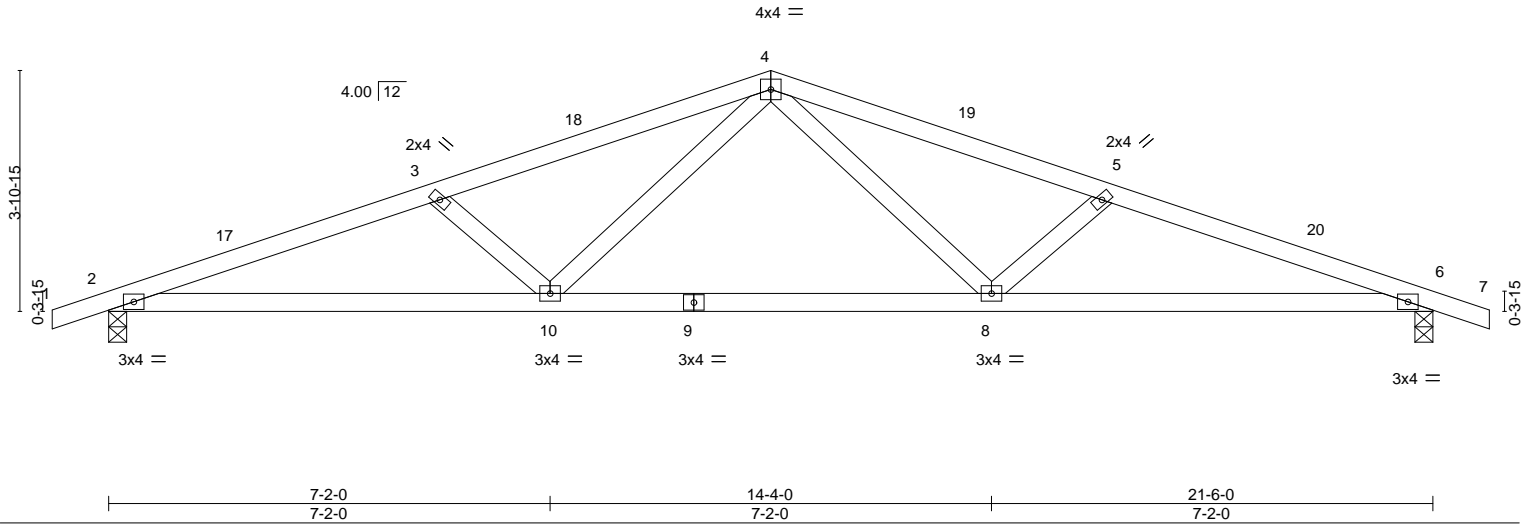

LOADING (psf)	SPACING-	CSI.	DEFL.	PLATES	GRIP
TCLL (roof) 20.0	2-0-0	TC 0.53	in (loc) l/defl L/d	MT20	244/190
Snow (Pf/Pg) 15.4/20.0	Plate Grip DOL 1.15	BC 0.67	Vert(LL) -0.10 8-10 >999 240		
TCDL 10.0	Lumber DOL 1.15	WB 0.25	Vert(CT) -0.23 8-10 >999 180		
BCLL 0.0 *	Rep Stress Incr YES	Matrix-MS	Horz(CT) 0.06 6 n/a n/a		
BCDL 10.0	Code IRC2018/TPI2014			Weight: 91 lb	FT = 20%

LUMBER-	BRACING-
TOP CHORD 2x4 SP No.2	TOP CHORD Structural wood sheathing directly applied or 3-8-11 oc purlins.
BOT CHORD 2x4 SP No.2	BOT CHORD Rigid ceiling directly applied or 10-0-0 oc bracing.
WEBS 2x4 SP No.3	

REACTIONS. (size) 2=0-3-8, 6=0-3-8
 Max Horz 2=41(LC 15)
 Max Uplift 2=81(LC 16), 6=81(LC 16)
 Max Grav 2=915(LC 2), 6=915(LC 2)

FORCES. (lb) - Max. Comp./Max. Ten. - All forces 250 (lb) or less except when shown.
 TOP CHORD 2-3=-2095/377, 3-4=-1836/317, 4-5=-1836/317, 5-6=-2095/377
 BOT CHORD 2-10=-305/1967, 8-10=-155/1283, 6-8=-308/1967
 WEBS 4-8=-42/603, 5-8=-414/168, 4-10=-42/603, 3-10=-414/168

- NOTES-**
- 1) Unbalanced roof live loads have been considered for this design.
 - 2) Wind: ASCE 7-16; Vult=130mph (3-second gust) Vasd=103mph; TCCL=6.0psf; BCDL=6.0psf; h=25ft; B=45ft; L=24ft; eave=4ft; Cat. II; Exp B; Enclosed; MWFRS (directional) and C-C Exterior(2E) -0-11-0 to 2-1-0, Interior(1) 2-1-0 to 10-9-0, Exterior(2R) 10-9-0 to 13-9-0, Interior(1) 13-9-0 to 22-5-0 zone; cantilever left and right exposed; end vertical left and right exposed; C-C for members and forces & MWFRS for reactions shown; Lumber DOL=1.60 plate grip DOL=1.60
 - 3) TCLL: ASCE 7-16; Pr=20.0 psf (roof LL: Lum DOL=1.15 Plate DOL=1.15); Pg=20.0 psf; Pf=15.4 psf (Lum DOL = 1.15 Plate DOL = 1.15); Is=1.0; Rough Cat B; Partially Exp.; Ce=1.0; Cs=1.0; Ct=1.10
 - 4) Unbalanced snow loads have been considered for this design.
 - 5) This truss has been designed for greater of min roof live load of 12.0 psf or 1.00 times flat roof load of 15.4 psf on overhangs non-concurrent with other live loads.
 - 6) This truss has been designed for a 10.0 psf bottom chord live load nonconcurrent with any other live loads.
 - 7) * This truss has been designed for a live load of 20.0psf on the bottom chord in all areas where a rectangle 3-6-0 tall by 2-0-0 wide will fit between the bottom chord and any other members.
 - 8) Provide mechanical connection (by others) of truss to bearing plate capable of withstanding 100 lb uplift at joint(s) 2, 6.
 - 9) This truss is designed in accordance with the 2018 International Residential Code sections R502.11.1 and R802.10.2 and referenced standard ANSI/TPI 1.



April 10, 2026

Job 26-1922-A	Truss TR01	Truss Type Monopitch	Qty 4	Ply 1	MDP-LOT #16 ROOF	81045335
------------------	---------------	-------------------------	----------	----------	------------------	----------

Riverside Roof Truss, LLC, Danville, Va - 24541,

8.830 s Mar 11 2026 MiTek Industries, Inc. Fri Apr 10 06:38:55 2026 Page 1

ID:kk2_eRZGXXvKblGikzSpyNzs9fO-EqDhRFpJ3rgF1s5k18olpD7lrAwNlFK7uYlFH3zSCAk

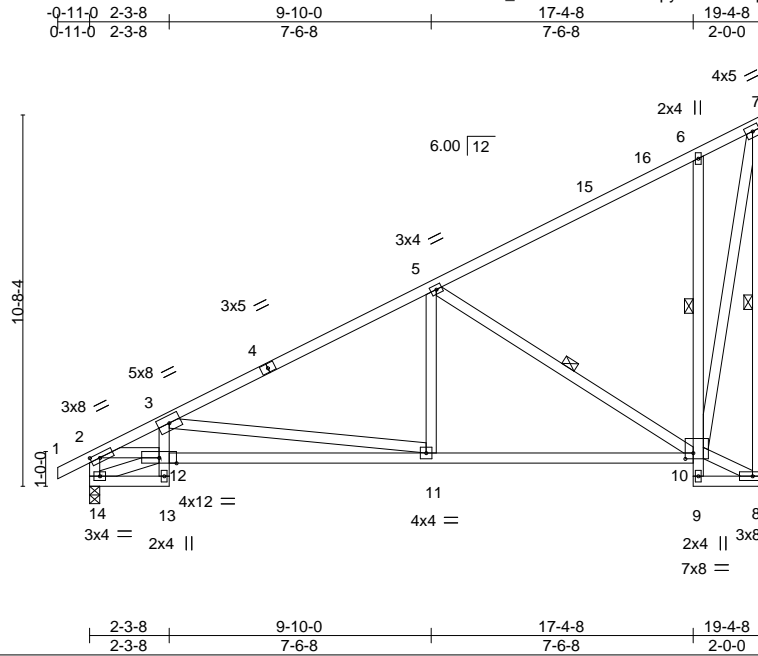

Scale = 1:66.3

Plate Offsets (X,Y)-- [2:0-3-3,0-1-8], [10:0-2-12,0-2-0]

LOADING (psf)	SPACING-	CSI.	DEFL.	PLATES	GRIP
TCLL (roof) 20.0	2-0-0	TC 0.84	in (loc) l/defl L/d	MT20	244/190
Snow (Pf/Pg) 15.4/20.0	Plate Grip DOL 1.15	BC 0.75	Vert(LL) -0.09 11-12 >999 240		
TCDL 10.0	Lumber DOL 1.15	WB 0.98	Vert(CT) -0.22 11-12 >999 180		
BCLL 0.0 *	Rep Stress Incr YES	Matrix-MS	Horz(CT) 0.08 8 n/a n/a		
BCDL 10.0	Code IRC2018/TPI2014			Weight: 147 lb	FT = 20%

LUMBER-
TOP CHORD 2x4 SP No.2
BOT CHORD 2x4 SP No.2 *Except*
3-13,6-9: 2x4 SP No.3
WEBS 2x4 SP No.3 *Except*
7-8: 2x4 SP No.2

BRACING-
TOP CHORD Structural wood sheathing directly applied or 4-8-7 oc purlins, except end verticals.
BOT CHORD Rigid ceiling directly applied or 5-11-11 oc bracing. Except:
1 Row at midpt 6-10
WEBS 1 Row at midpt 7-8, 5-10

REACTIONS. (size) 8=Mechanical, 14=0-3-8
Max Horz 14=366(LC 13)
Max Uplift 8=63(LC 16), 14=63(LC 16)
Max Grav 8=793(LC 21), 14=829(LC 2)

FORCES. (lb) - Max. Comp./Max. Ten. - All forces 250 (lb) or less except when shown.
TOP CHORD 2-3=-1531/360, 3-5=-1020/174, 5-6=-351/149, 6-7=-270/193, 7-8=-762/239,
2-14=-756/172
BOT CHORD 3-12=-164/259, 11-12=-966/1674, 10-11=-371/829, 6-10=-428/278
WEBS 3-11=-852/600, 5-11=0/411, 5-10=-788/240, 8-10=-214/310, 7-10=-309/893,
2-12=-317/1317, 12-14=-478/312

NOTES-

- Unbalanced roof live loads have been considered for this design.
- Wind: ASCE 7-16; Vult=130mph (3-second gust) Vasd=103mph; TCDL=6.0psf; BCDL=6.0psf; h=25ft; B=45ft; L=24ft; eave=4ft; Cat. II; Exp B; Enclosed; MWFRS (directional) and C-C Exterior(2E) -0-11-0 to 2-1-12, Interior(1) 2-1-12 to 19-2-12 zone; cantilever left and right exposed ; end vertical left and right exposed;C-C for members and forces & MWFRS for reactions shown; Lumber DOL=1.60 plate grip DOL=1.60
- TCLL: ASCE 7-16; Pr=20.0 psf (roof LL: Lum DOL=1.15 Plate DOL=1.15); Pg=20.0 psf; Pf=15.4 psf (Lum DOL = 1.15 Plate DOL = 1.15); Is=1.0; Rough Cat B; Partially Exp.; Ce=1.0; Cs=1.00; Ct=1.10
- Unbalanced snow loads have been considered for this design.
- This truss has been designed for greater of min roof live load of 12.0 psf or 1.00 times flat roof load of 15.4 psf on overhangs non-concurrent with other live loads.
- This truss has been designed for a 10.0 psf bottom chord live load nonconcurrent with any other live loads.
- * This truss has been designed for a live load of 20.0psf on the bottom chord in all areas where a rectangle 3-6-0 tall by 2-0-0 wide will fit between the bottom chord and any other members.
- Refer to girder(s) for truss to truss connections.
- Provide mechanical connection (by others) of truss to bearing plate capable of withstanding 100 lb uplift at joint(s) 8, 14.
- This truss is designed in accordance with the 2018 International Residential Code sections R502.11.1 and R802.10.2 and referenced standard ANSI/TPI 1.



April 10, 2026

WARNING - Verify design parameters and READ NOTES ON THIS AND INCLUDED MITEK REFERENCE PAGE MII-7473 rev. 1/2/2023 BEFORE USE.
Design valid for use only with MiTek® connectors. This design is based only upon parameters shown, and is for an individual building component, not a truss system. Before use, the building designer must verify the applicability of design parameters and properly incorporate this design into the overall building design. Bracing indicated is to prevent buckling of individual truss web and/or chord members only. Additional temporary and permanent bracing is always required for stability and to prevent collapse with possible personal injury and property damage. For general guidance regarding the fabrication, storage, delivery, erection and bracing of trusses and truss systems, see **ANSI/TPI Quality Criteria and DSB-22** available from Truss Plate Institute (www.tpinst.org) and **BCSI Building Component Safety Information** available from the Structural Building Component Association (www.sbcacomponents.com)

ENGINEERING BY
TRENCO
A MiTek Affiliate
818 Soundside Road
Edenton, NC 27932

Job 26-1922-A	Truss V01	Truss Type Valley	Qty 1	Ply 1	MDP-LOT #16 ROOF Job Reference (optional)	I81045336
------------------	--------------	----------------------	----------	----------	--	-----------

Riverside Roof Truss, LLC,

Danville, Va - 24541,

8.830 s Mar 11 2026 MiTek Industries, Inc. Fri Apr 10 06:38:55 2026 Page 1

ID:kk2_eRZGXXvKbIGikzSpyNzs9fO-EqDhRFpJ3rgF1s5k18olpD7NOA10iUa7uYIFH3zSCAK

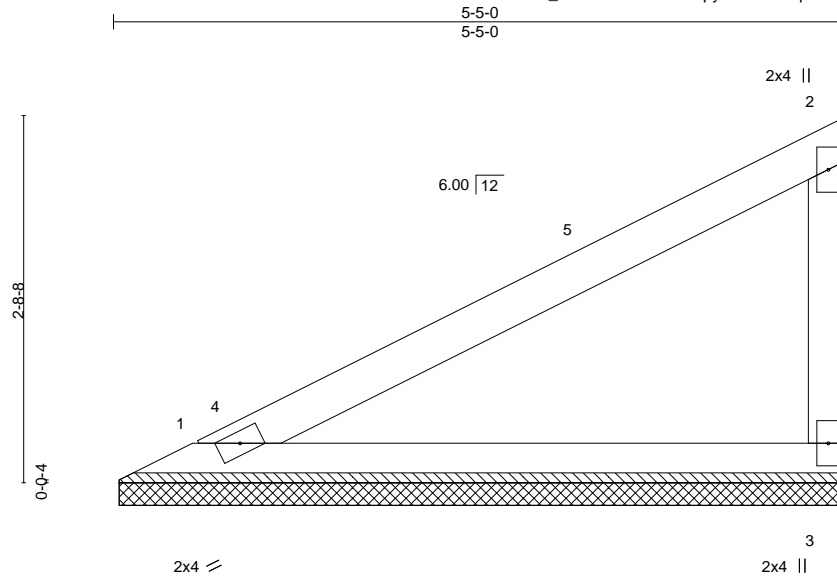

Scale = 1:17.0

LOADING (psf)	SPACING-	CSI.	DEFL.	PLATES	GRIP
TCLL (roof) 20.0	2-0-0	TC 0.55	in (loc) l/defl L/d	MT20	244/190
Snow (Pf/Pg) 15.4/20.0	Plate Grip DOL 1.15	BC 0.27	Vert(LL) n/a - n/a 999		
TCDL 10.0	Lumber DOL 1.15	WB 0.00	Vert(CT) n/a - n/a 999		
BCLL 0.0 *	Rep Stress Incr YES	Matrix-P	Horz(CT) 0.00 3 n/a n/a		
BCDL 10.0	Code IRC2018/TPI2014			Weight: 19 lb	FT = 20%

LUMBER-
TOP CHORD 2x4 SP No.2
BOT CHORD 2x4 SP No.2
WEBS 2x4 SP No.3

BRACING-
TOP CHORD Structural wood sheathing directly applied or 5-5-0 oc purlins, except end verticals.
BOT CHORD Rigid ceiling directly applied or 10-0-0 oc bracing.

REACTIONS. (size) 1=5-4-8, 3=5-4-8
Max Horz 1=81(LC 15)
Max Uplift 1=8(LC 16), 3=15(LC 16)
Max Grav 1=229(LC 20), 3=229(LC 20)

FORCES. (lb) - Max. Comp./Max. Ten. - All forces 250 (lb) or less except when shown.

NOTES-

- Unbalanced roof live loads have been considered for this design.
- Wind: ASCE 7-16; Vult=130mph (3-second gust) Vasd=103mph; TCCL=6.0psf; BCDL=6.0psf; h=25ft; B=45ft; L=24ft; eave=4ft; Cat. II; Exp B; Enclosed; MWFRS (directional) and C-C Exterior(2E) 0-7-9 to 3-7-9, Interior(1) 3-7-9 to 5-3-4 zone; cantilever left and right exposed; end vertical left and right exposed; C-C for members and forces & MWFRS for reactions shown; Lumber DOL=1.60 plate grip DOL=1.60
- TCLL: ASCE 7-16; Pr=20.0 psf (roof LL: Lum DOL=1.15 Plate DOL=1.15); Pg=20.0 psf; Pf=15.4 psf (Lum DOL = 1.15 Plate DOL = 1.15); Is=1.0; Rough Cat B; Partially Exp.; Ce=1.0; Cs=1.00; Ct=1.10
- Unbalanced snow loads have been considered for this design.
- Gable requires continuous bottom chord bearing.
- This truss has been designed for a 10.0 psf bottom chord live load nonconcurrent with any other live loads.
- * This truss has been designed for a live load of 20.0psf on the bottom chord in all areas where a rectangle 3-6-0 tall by 2-0-0 wide will fit between the bottom chord and any other members.
- Provide mechanical connection (by others) of truss to bearing plate capable of withstanding 100 lb uplift at joint(s) 1, 3.
- This truss is designed in accordance with the 2018 International Residential Code sections R502.11.1 and R802.10.2 and referenced standard ANSI/TPI 1.



April 10, 2026

WARNING - Verify design parameters and READ NOTES ON THIS AND INCLUDED MITEK REFERENCE PAGE MII-7473 rev. 1/2/2023 BEFORE USE.

Design valid for use only with MiTek® connectors. This design is based only upon parameters shown, and is for an individual building component, not a truss system. Before use, the building designer must verify the applicability of design parameters and properly incorporate this design into the overall building design. Bracing indicated is to prevent buckling of individual truss web and/or chord members only. Additional temporary and permanent bracing is always required for stability and to prevent collapse with possible personal injury and property damage. For general guidance regarding the fabrication, storage, delivery, erection and bracing of trusses and truss systems, see **ANSI/TPI1 Quality Criteria and DSB-22** available from Truss Plate Institute (www.tpinst.org) and **BCSI Building Component Safety Information** available from the Structural Building Component Association (www.sbcacomponents.com)



818 Soundside Road
Edenton, NC 27932

Job 26-1922-A	Truss V02	Truss Type Valley	Qty 1	Ply 1	MDP-LOT #16 ROOF Job Reference (optional)	I81045337
------------------	--------------	----------------------	----------	----------	--	-----------

Riverside Roof Truss, LLC, Danville, Va - 24541,

8.830 s Mar 11 2026 MiTek Industries, Inc. Fri Apr 10 06:38:56 2026 Page 1

ID:kk2_eRZGXxvKblGikzSpyNzs9fO-j0n3eayq9o6f0gwrJXMqgf3aRURxpG6CVppWzSCAJ

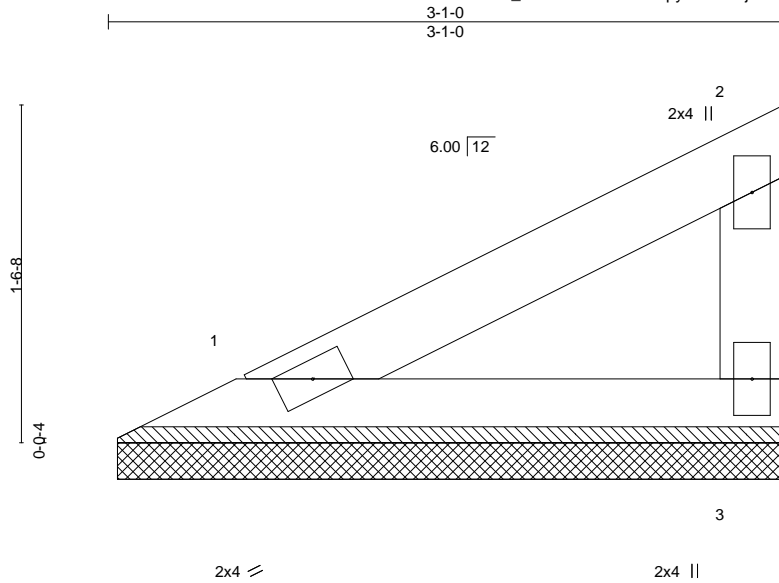

Scale = 1:10.5

LOADING (psf)	SPACING-	CSI.	DEFL.	PLATES	GRIP
TCLL (roof) 20.0	2-0-0	TC 0.11	in (loc) l/defl L/d	MT20	244/190
Snow (Pf/Pg) 15.4/20.0	Plate Grip DOL 1.15	BC 0.06	Vert(LL) n/a - n/a 999		
TCDL 10.0	Lumber DOL 1.15	WB 0.00	Vert(CT) n/a - n/a 999		
BCLL 0.0 *	Rep Stress Incr YES	Matrix-P	Horz(CT) 0.00 3 n/a n/a		
BCDL 10.0	Code IRC2018/TPI2014			Weight: 10 lb	FT = 20%

LUMBER-
TOP CHORD 2x4 SP No.2
BOT CHORD 2x4 SP No.2
WEBS 2x4 SP No.3

BRACING-
TOP CHORD Structural wood sheathing directly applied or 3-1-0 oc purlins, except end verticals.
BOT CHORD Rigid ceiling directly applied or 10-0-0 oc bracing.

REACTIONS. (size) 1=3-0-8, 3=3-0-8
Max Horz 1=41(LC 13)
Max Uplift 1=4(LC 16), 3=7(LC 16)
Max Grav 1=104(LC 20), 3=104(LC 20)

FORCES. (lb) - Max. Comp./Max. Ten. - All forces 250 (lb) or less except when shown.

NOTES-

- 1) Unbalanced roof live loads have been considered for this design.
- 2) Wind: ASCE 7-16; Vult=130mph (3-second gust) Vasd=103mph; TCCL=6.0psf; BCDL=6.0psf; h=25ft; B=45ft; L=24ft; eave=4ft; Cat. II; Exp B; Enclosed; MWFRS (directional) and C-C Exterior(2E) zone; cantilever left and right exposed ; end vertical left and right exposed;C-C for members and forces & MWFRS for reactions shown; Lumber DOL=1.60 plate grip DOL=1.60
- 3) TCLL: ASCE 7-16; Pr=20.0 psf (roof LL: Lum DOL=1.15 Plate DOL=1.15); Pg=20.0 psf; Pf=15.4 psf (Lum DOL = 1.15 Plate DOL = 1.15); Is=1.0; Rough Cat B; Partially Exp.; Ce=1.0; Cs=1.00; Ct=1.10
- 4) Unbalanced snow loads have been considered for this design.
- 5) Gable requires continuous bottom chord bearing.
- 6) This truss has been designed for a 10.0 psf bottom chord live load nonconcurrent with any other live loads.
- 7) * This truss has been designed for a live load of 20.0psf on the bottom chord in all areas where a rectangle 3-6-0 tall by 2-0-0 wide will fit between the bottom chord and any other members.
- 8) Provide mechanical connection (by others) of truss to bearing plate capable of withstanding 100 lb uplift at joint(s) 1, 3.
- 9) This truss is designed in accordance with the 2018 International Residential Code sections R502.11.1 and R802.10.2 and referenced standard ANSI/TPI 1.

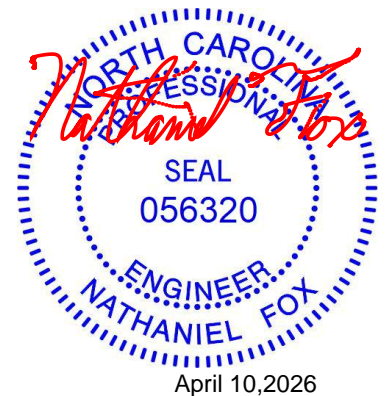

April 10, 2026

WARNING - Verify design parameters and READ NOTES ON THIS AND INCLUDED MITEK REFERENCE PAGE MII-7473 rev. 1/2/2023 BEFORE USE.

Design valid for use only with MiTek® connectors. This design is based only upon parameters shown, and is for an individual building component, not a truss system. Before use, the building designer must verify the applicability of design parameters and properly incorporate this design into the overall building design. Bracing indicated is to prevent buckling of individual truss web and/or chord members only. Additional temporary and permanent bracing is always required for stability and to prevent collapse with possible personal injury and property damage. For general guidance regarding the fabrication, storage, delivery, erection and bracing of trusses and truss systems, see **ANSI/TPH Quality Criteria and DSB-22** available from Truss Plate Institute (www.tpinst.org) and **BCSI Building Component Safety Information** available from the Structural Building Component Association (www.sbcacomponents.com)



818 Soundside Road
Edenton, NC 27932

Job 26-1922-A	Truss V03	Truss Type Valley	Qty 1	Ply 1	MDP-LOT #16 ROOF Job Reference (optional)	81045338
------------------	--------------	----------------------	----------	----------	--	----------

Riverside Roof Truss, LLC,

Danville, Va - 24541,

8.830 s Mar 11 2026 MiTek Industries, Inc. Fri Apr 10 06:38:56 2026 Page 1

ID:kk2_eRZGXXvKblGikzSpyNzs9fO-j0n3eaqyq9o6f0gwrJXMqGcBaPARxpG6CVppWzSCAj

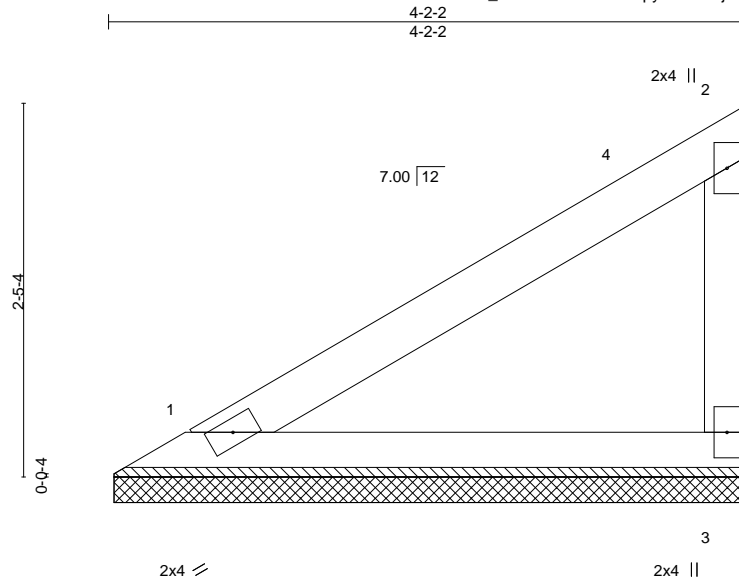

Scale = 1:15.0

LOADING (psf)	SPACING-	CSI.	DEFL.	PLATES	GRIP
TCLL (roof) 20.0	2-0-0	TC 0.29	in (loc) l/defl L/d	MT20	244/190
Snow (Pf/Pg) 15.4/20.0	Plate Grip DOL 1.15	BC 0.14	Vert(LL) n/a - n/a 999		
TCDL 10.0	Lumber DOL 1.15	WB 0.00	Vert(CT) n/a - n/a 999		
BCLL 0.0 *	Rep Stress Incr YES	Matrix-P	Horz(CT) 0.00 3 n/a n/a		
BCDL 10.0	Code IRC2018/TPI2014			Weight: 15 lb	FT = 20%

LUMBER-
 TOP CHORD 2x4 SP No.2
 BOT CHORD 2x4 SP No.2
 WEBS 2x4 SP No.3

BRACING-
 TOP CHORD Structural wood sheathing directly applied or 4-2-2 oc purlins, except end verticals.
 BOT CHORD Rigid ceiling directly applied or 10-0-0 oc bracing.

REACTIONS. (size) 1=4-1-11, 3=4-1-11
 Max Horz 1=71(LC 15)
 Max Uplift 1=5(LC 16), 3=14(LC 13)
 Max Grav 1=169(LC 20), 3=169(LC 20)

FORCES. (lb) - Max. Comp./Max. Ten. - All forces 250 (lb) or less except when shown.

NOTES-

- 1) Unbalanced roof live loads have been considered for this design.
- 2) Wind: ASCE 7-16; Vult=130mph (3-second gust) Vasd=103mph; TCCL=6.0psf; BCDL=6.0psf; h=25ft; B=45ft; L=24ft; eave=4ft; Cat. II; Exp B; Enclosed; MWFRS (directional) and C-C Exterior(2E) 0-6-8 to 3-6-8, Interior(1) 3-6-8 to 4-0-6 zone; cantilever left and right exposed; end vertical left and right exposed; C-C for members and forces & MWFRS for reactions shown; Lumber DOL=1.60 plate grip DOL=1.60
- 3) TCLL: ASCE 7-16; Pr=20.0 psf (roof LL: Lum DOL=1.15 Plate DOL=1.15); Pg=20.0 psf; Pf=15.4 psf (Lum DOL = 1.15 Plate DOL = 1.15); Is=1.0; Rough Cat B; Partially Exp.; Ce=1.0; Cs=1.00; Ct=1.10
- 4) Unbalanced snow loads have been considered for this design.
- 5) Gable requires continuous bottom chord bearing.
- 6) This truss has been designed for a 10.0 psf bottom chord live load nonconcurrent with any other live loads.
- 7) * This truss has been designed for a live load of 20.0psf on the bottom chord in all areas where a rectangle 3-6-0 tall by 2-0-0 wide will fit between the bottom chord and any other members.
- 8) Provide mechanical connection (by others) of truss to bearing plate capable of withstanding 100 lb uplift at joint(s) 1, 3.
- 9) This truss is designed in accordance with the 2018 International Residential Code sections R502.11.1 and R802.10.2 and referenced standard ANSI/TPI 1.



April 10, 2026

WARNING - Verify design parameters and READ NOTES ON THIS AND INCLUDED MITEK REFERENCE PAGE MII-7473 rev. 1/2/2023 BEFORE USE.

Design valid for use only with MiTek® connectors. This design is based only upon parameters shown, and is for an individual building component, not a truss system. Before use, the building designer must verify the applicability of design parameters and properly incorporate this design into the overall building design. Bracing indicated is to prevent buckling of individual truss web and/or chord members only. Additional temporary and permanent bracing is always required for stability and to prevent collapse with possible personal injury and property damage. For general guidance regarding the fabrication, storage, delivery, erection and bracing of trusses and truss systems, see **ANSI/TP1 Quality Criteria and DSB-22** available from Truss Plate Institute (www.tpinst.org) and **BCSI Building Component Safety Information** available from the Structural Building Component Association (www.sbcacomponents.com)

ENGINEERING BY
TRENCO
 A MiTek Affiliate

818 Soundside Road
 Edenton, NC 27932

Job 26-1922-A	Truss V04	Truss Type Valley	Qty 1	Ply 1	MDP-LOT #16 ROOF Job Reference (optional)	181045339
------------------	--------------	----------------------	----------	----------	--	-----------

Riverside Roof Truss, LLC, Danville, Va - 24541,

8.830 s Mar 11 2026 MiTek Industries, Inc. Fri Apr 10 06:38:56 2026 Page 1

ID:kk2_eRZGXXvKblGikzSpyNzs9fO-j0n3eaqyq9o6f0gwbrJXMqggoaRtRxpG6CVppWzSCAj

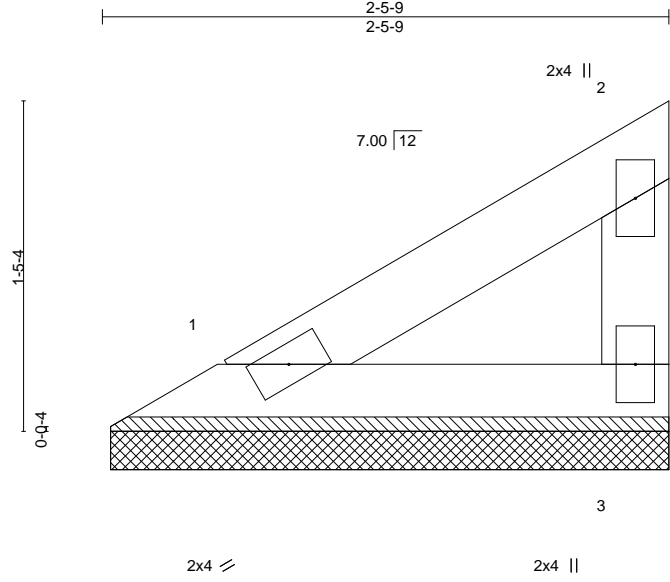

Scale = 1:10.0

LOADING (psf)	SPACING-	CSI.	DEFL.	PLATES	GRIP
TCLL (roof) 20.0	2-0-0	TC 0.06	in (loc) l/defl L/d	MT20	244/190
Snow (Pf/Pg) 15.4/20.0	Plate Grip DOL 1.15	BC 0.03	Vert(LL) n/a - n/a 999		
TCDL 10.0	Lumber DOL 1.15	WB 0.00	Vert(CT) n/a - n/a 999		
BCLL 0.0 *	Rep Stress Incr YES	Matrix-P	Horz(CT) 0.00 3 n/a n/a		
BCDL 10.0	Code IRC2018/TPI2014			Weight: 8 lb	FT = 20%

LUMBER-	BRACING-
TOP CHORD 2x4 SP No.2	TOP CHORD Structural wood sheathing directly applied or 2-5-9 oc purlins, except end verticals.
BOT CHORD 2x4 SP No.2	BOT CHORD Rigid ceiling directly applied or 10-0-0 oc bracing.
WEBS 2x4 SP No.3	

REACTIONS. (size) 1=2-5-2, 3=2-5-2
 Max Horz 1=36(LC 13)
 Max Uplift 1=2(LC 16), 3=7(LC 13)
 Max Grav 1=79(LC 20), 3=79(LC 20)

FORCES. (lb) - Max. Comp./Max. Ten. - All forces 250 (lb) or less except when shown.

NOTES-

- 1) Unbalanced roof live loads have been considered for this design.
- 2) Wind: ASCE 7-16; Vult=130mph (3-second gust) Vasd=103mph; TCCL=6.0psf; BCDL=6.0psf; h=25ft; B=45ft; L=24ft; eave=4ft; Cat. II; Exp B; Enclosed; MWFRS (directional) and C-C Exterior(2E) zone; cantilever left and right exposed ; end vertical left and right exposed;C-C for members and forces & MWFRS for reactions shown; Lumber DOL=1.60 plate grip DOL=1.60
- 3) TCLL: ASCE 7-16; Pr=20.0 psf (roof LL: Lum DOL=1.15 Plate DOL=1.15); Pg=20.0 psf; Pf=15.4 psf (Lum DOL = 1.15 Plate DOL = 1.15); Is=1.0; Rough Cat B; Partially Exp.; Ce=1.0; Cs=1.00; Ct=1.10
- 4) Unbalanced snow loads have been considered for this design.
- 5) Gable requires continuous bottom chord bearing.
- 6) This truss has been designed for a 10.0 psf bottom chord live load nonconcurrent with any other live loads.
- 7) * This truss has been designed for a live load of 20.0psf on the bottom chord in all areas where a rectangle 3-6-0 tall by 2-0-0 wide will fit between the bottom chord and any other members.
- 8) Provide mechanical connection (by others) of truss to bearing plate capable of withstanding 100 lb uplift at joint(s) 1, 3.
- 9) This truss is designed in accordance with the 2018 International Residential Code sections R502.11.1 and R802.10.2 and referenced standard ANSI/TPI 1.



April 10, 2026

Job 26-1922-A	Truss V05	Truss Type Valley	Qty 1	Ply 1	MDP-LOT #16 ROOF Job Reference (optional)	81045340
------------------	--------------	----------------------	----------	----------	--	----------

Riverside Roof Truss, LLC, Danville, Va - 24541,

8.830 s Mar 11 2026 MiTek Industries, Inc. Fri Apr 10 06:38:57 2026 Page 1

ID:kk2_eRZGXxvKblGikzSpyNzs9fO-BDLRswrabSwzHAF69ZqmveDrg_mxAO3QLsEMLySCAi

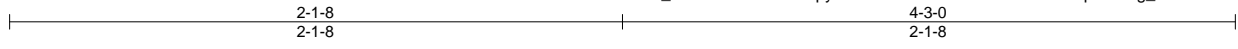

Scale: 1.5"=1'

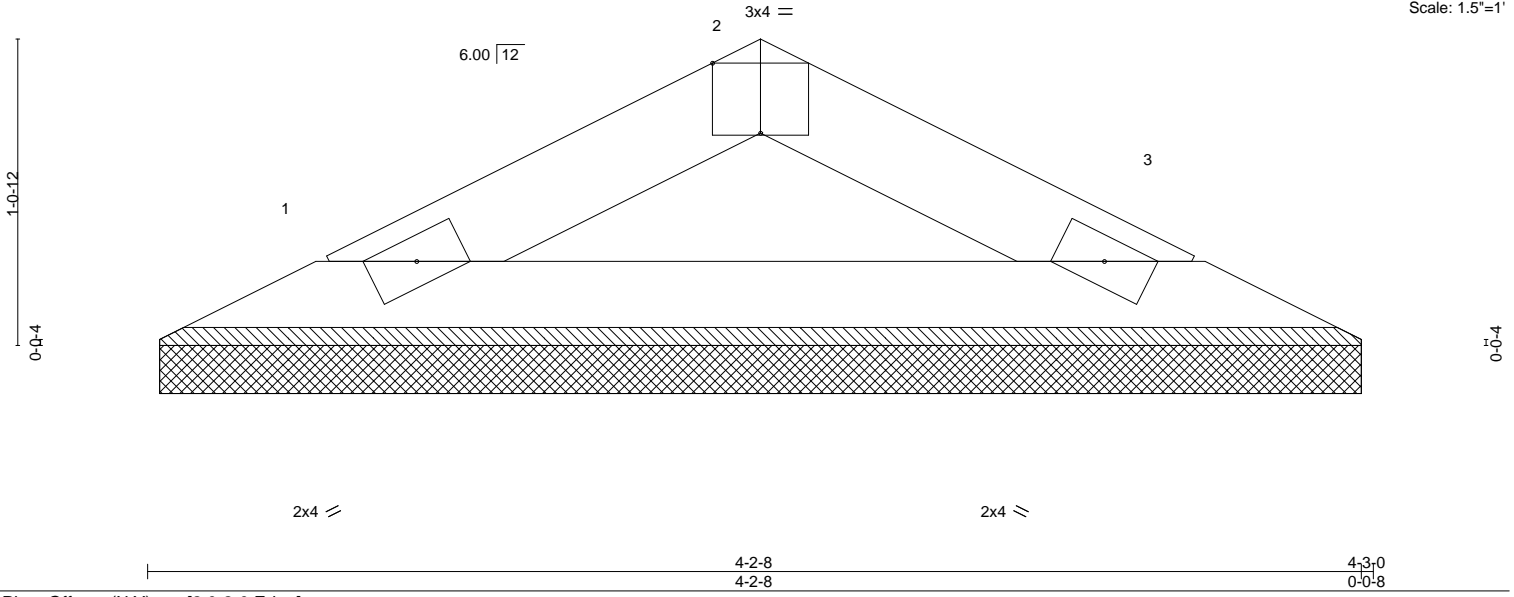

Plate Offsets (X,Y)-- [2:0-2-0,Edge]		4-2-8	4-2-8	4-3-0	0-0-8
LOADING (psf)	SPACING-	CSI.	DEFL.	PLATES	GRIP
TCLL (roof) 20.0	2-0-0	TC 0.05	in (loc) l/defl L/d	MT20	244/190
Snow (Pf/Pg) 15.4/20.0	Plate Grip DOL 1.15	BC 0.11	Vert(LL) n/a - n/a 999		
TCDL 10.0	Lumber DOL 1.15	WB 0.00	Vert(CT) n/a - n/a 999		
BCLL 0.0 *	Rep Stress Incr YES	Matrix-P	Horz(CT) 0.00 3 n/a n/a		
BCDL 10.0	Code IRC2018/TPI2014			Weight: 11 lb	FT = 20%

LUMBER-	BRACING-
TOP CHORD 2x4 SP No.2	TOP CHORD Structural wood sheathing directly applied or 4-3-0 oc purlins.
BOT CHORD 2x4 SP No.2	BOT CHORD Rigid ceiling directly applied or 10-0-0 oc bracing.

REACTIONS. (size) 1=4-2-0, 3=4-2-0
 Max Horz 1=12(LC 15)
 Max Uplift 1=7(LC 16), 3=7(LC 16)
 Max Grav 1=120(LC 2), 3=120(LC 2)

FORCES. (lb) - Max. Comp./Max. Ten. - All forces 250 (lb) or less except when shown.

NOTES-

- Unbalanced roof live loads have been considered for this design.
- Wind: ASCE 7-16; Vult=130mph (3-second gust) Vasd=103mph; TCCL=6.0psf; BCDL=6.0psf; h=25ft; B=45ft; L=24ft; eave=4ft; Cat. II; Exp B; Enclosed; MWFRS (directional) and C-C Exterior(2E) zone; cantilever left and right exposed ; end vertical left and right exposed;C-C for members and forces & MWFRS for reactions shown; Lumber DOL=1.60 plate grip DOL=1.60
- TCLL: ASCE 7-16; Pr=20.0 psf (roof LL: Lum DOL=1.15 Plate DOL=1.15); Pg=20.0 psf; Pf=15.4 psf (Lum DOL = 1.15 Plate DOL = 1.15); Is=1.0; Rough Cat B; Partially Exp.; Ce=1.0; Cs=1.00; Ct=1.10
- Unbalanced snow loads have been considered for this design.
- Gable requires continuous bottom chord bearing.
- This truss has been designed for a 10.0 psf bottom chord live load nonconcurrent with any other live loads.
- * This truss has been designed for a live load of 20.0psf on the bottom chord in all areas where a rectangle 3-6-0 tall by 2-0-0 wide will fit between the bottom chord and any other members.
- Provide mechanical connection (by others) of truss to bearing plate capable of withstanding 100 lb uplift at joint(s) 1, 3.
- This truss is designed in accordance with the 2018 International Residential Code sections R502.11.1 and R802.10.2 and referenced standard ANSI/TPI 1.



April 10, 2026

Job 26-1922-A	Truss V06	Truss Type Valley	Qty 1	Ply 1	MDP-LOT #16 ROOF	I81045341
------------------	--------------	----------------------	----------	----------	------------------	-----------

Riverside Roof Truss, LLC, Danville, Va - 24541,

8.830 s Mar 11 2026 MiTek Industries, Inc. Fri Apr 10 06:38:57 2026 Page 1

ID:kk2_eRZGXvKblGikzSpyNzs9fO-BDLRswrabSwzHAF69ZqmveDn2_miAORQLsEMLyzSCAI

Job Reference (optional)



Scale = 1:15.1

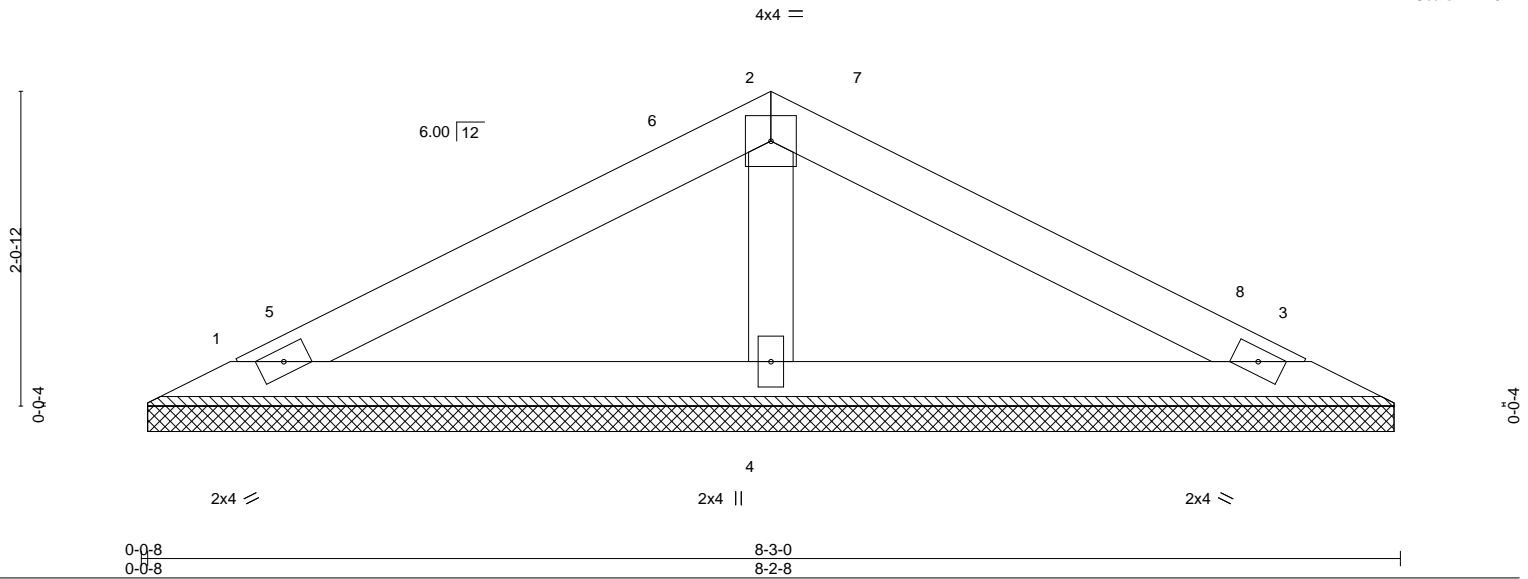

LOADING (psf)	SPACING-	CSI.	DEFL.	PLATES	GRIP
TCLL (roof) 20.0	2-0-0	TC 0.28	in (loc) l/defl L/d	MT20	244/190
Snow (Pf/Pg) 15.4/20.0	Plate Grip DOL 1.15	BC 0.12	Vert(LL) n/a - n/a 999		
TCDL 10.0	Lumber DOL 1.15	WB 0.04	Vert(CT) n/a - n/a 999		
BCLL 0.0 *	Rep Stress Incr YES	Matrix-P	Horz(CT) 0.00 3 n/a n/a		
BCDL 10.0	Code IRC2018/TPI2014			Weight: 26 lb	FT = 20%

LUMBER-	BRACING-
TOP CHORD 2x4 SP No.2	TOP CHORD Structural wood sheathing directly applied or 6-0-0 oc purlins.
BOT CHORD 2x4 SP No.2	BOT CHORD Rigid ceiling directly applied or 10-0-0 oc bracing.
OTHERS 2x4 SP No.3	

REACTIONS. (size) 1=8-2-0, 3=8-2-0, 4=8-2-0
 Max Horz 1=-29(LC 14)
 Max Uplift 1=-21(LC 16), 3=-21(LC 16)
 Max Grav 1=166(LC 20), 3=166(LC 21), 4=276(LC 2)

FORCES. (lb) - Max. Comp./Max. Ten. - All forces 250 (lb) or less except when shown.

NOTES-

- 1) Unbalanced roof live loads have been considered for this design.
- 2) Wind: ASCE 7-16; Vult=130mph (3-second gust) Vasd=103mph; TCCL=6.0psf; BCDL=6.0psf; h=25ft; B=45ft; L=24ft; eave=4ft; Cat. II; Exp B; Enclosed; MWFRS (directional) and C-C Exterior(2E) 0-7-9 to 3-7-9, Interior(1) 3-7-9 to 4-1-8, Exterior(2R) 4-1-8 to 7-1-8, Interior(1) 7-1-8 to 7-7-7 zone; cantilever left and right exposed; end vertical left and right exposed; C-C for members and forces & MWFRS for reactions shown; Lumber DOL=1.60 plate grip DOL=1.60
- 3) TCLL: ASCE 7-16; Pr=20.0 psf (roof LL: Lum DOL=1.15 Plate DOL=1.15); Pg=20.0 psf; Pf=15.4 psf (Lum DOL = 1.15 Plate DOL = 1.15); Is=1.0; Rough Cat B; Partially Exp.; Ce=1.0; Cs=1.00; Ct=1.10
- 4) Unbalanced snow loads have been considered for this design.
- 5) Gable requires continuous bottom chord bearing.
- 6) This truss has been designed for a 10.0 psf bottom chord live load nonconcurrent with any other live loads.
- 7) * This truss has been designed for a live load of 20.0psf on the bottom chord in all areas where a rectangle 3-6-0 tall by 2-0-0 wide will fit between the bottom chord and any other members.
- 8) Provide mechanical connection (by others) of truss to bearing plate capable of withstanding 100 lb uplift at joint(s) 1, 3.
- 9) This truss is designed in accordance with the 2018 International Residential Code sections R502.11.1 and R802.10.2 and referenced standard ANSI/TPI 1.



April 10, 2026

Symbols

PLATE LOCATION AND ORIENTATION

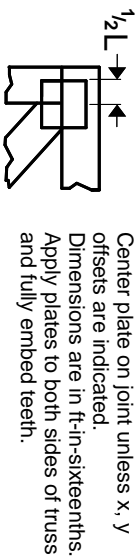

Center plate on joint unless x, y offsets are indicated. Dimensions are in ft-in-sixteenths. Apply plates to both sides of truss and fully embed teeth.

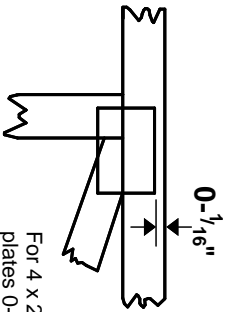

For 4 x 2 orientation, locate plates 0- 1/16" from outside edge of truss.

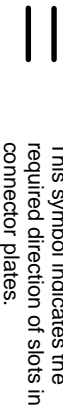

This symbol indicates the required direction of slots in connector plates.

* Plate location details available in MITek software or upon request.

PLATE SIZE

4 X 4

The first dimension is the plate width measured perpendicular to slots. Second dimension is the length parallel to slots.

LATERAL BRACING LOCATION



Indicated by symbol shown and/or by text in the bracing section of the output. Use T or I bracing if indicated.

BEARING

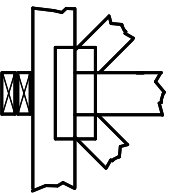

Indicates location where bearings (supports) occur. Icons vary but reaction section indicates joint number/letter where bearings occur. Min size shown is for crushing only.

Industry Standards:

ANSI/TP1: National Design Specification for Metal Plate Connected Wood Truss Construction.
DSB-22: Design Standard for Bracing.
BCSI: Building Component Safety Information, Guide to Good Practice for Handling, Installing, Restraining & Bracing of Metal Plate Connected Wood Trusses.

Numbering System

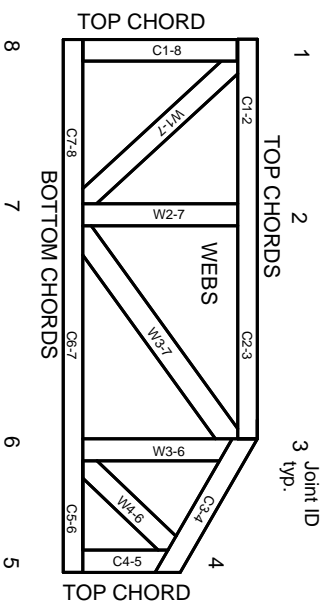

JOINTS ARE GENERALLY NUMBERED/LETTERED CLOCKWISE AROUND THE TRUSS STARTING AT THE JOINT FARTHEST TO THE LEFT.

CHORDS AND WEBS ARE IDENTIFIED BY END JOINT NUMBERS/LETTERS.

Product Code Approvals

ICC-ES Reports:

ESR-1988, ESR-2362, ESR-2685, ESR-3282
ESR-4722, ESL-1388

Design General Notes

Trusses are designed for wind loads in the plane of the truss unless otherwise shown.

Lumber design values are in accordance with ANSI/TP1 section 6.3. These truss designs rely on Lumber values established by others.

© 2023 MITek® All Rights Reserved

MITek

ENGINEERING BY
TRENGO
A MITek Affiliate

MITek Engineering Reference Sheet: MIL-7473 rev. 1/2/2023

General Safety Notes

Failure to Follow Could Cause Property Damage or Personal Injury

1. Additional stability/bracing for truss system, e.g. diagonal or X-bracing, is always required. See BCSI.
2. Truss bracing must be designed by an engineer. For wide truss spacing, individual lateral braces themselves may require bracing, or alternative Tor I bracing should be considered.
3. Never exceed the design loading shown and never stack materials on inadequately braced trusses.
4. Provide copies of this truss design to the building designer, erection supervisor, property owner and all other interested parties.
5. Cut members to bear tightly against each other.
6. Place plates on each face of truss at each joint and embed fully. Knots and wane at joint locations are regulated by ANSI/TP1 1.
7. Design assumes trusses will be suitably protected from the environment in accord with ANSI/TP1 1.
8. Unless otherwise noted, moisture content of lumber shall not exceed 19% at time of fabrication.
9. Unless expressly noted, this design is not applicable for use with fire retardant, preservative treated, or green lumber.
10. Camber is a non-structural consideration and is the responsibility of truss fabricator. General practice is to camber for dead load deflection.
11. Plate type, size, orientation and location dimensions indicated are minimum plating requirements.
12. Lumber used shall be of the species and size, and in all respects, equal to or better than that specified.
13. Top chords must be sheathed or purlins provided at spacing indicated on design.
14. Bottom chords require lateral bracing at 10 ft. spacing, or less, if no ceiling is installed, unless otherwise noted.
15. Connections not shown are the responsibility of others.
16. Do not cut or alter truss member or plate without prior approval of an engineer.
17. Install and load vertically unless indicated otherwise.
18. Use of green or treated lumber may pose unacceptable environmental, health or performance risks. Consult with project engineer before use.
19. Review all portions of this design (front, back, words and pictures) before use. Reviewing pictures alone is not sufficient.
20. Design assumes manufacture in accordance with ANSI/TP1 1 Quality Criteria.
21. The design does not take into account any dynamic or other loads other than those expressly stated.