

Location: _____



Lil

**Lil Max® – 7 to 50 GPM
HDPE Grease Interceptors**

Specification: MIFAB® Series Lil-(specify size) HDPE injection molded hydromechanical grease interceptor with flow rating of ____ (indicate) and grease holding capacity of ____ (indicate). Unit shall include: removable baffle assembly, deep seal trap covered by lid, sewer gas stopper, securing latches, internal stainless steel orifice flow control plate, internal air relief by pass, HDPE injection molded, non skid, rectangular gasketed lid(s). Interceptor shall be tested and certified to the P.D.I. Standard PDI-G101 (when installed with an external, vented flow control fitting), CSA B481, A.S.M.E. A112.14.3 and listed with I.A.P.M.O. Lil Max grease interceptors are also in compliance with International Plumbing Code (I.P.C.) / I.C.C. by I.A.P.M.O.

Function: Used in restaurants, kitchens, institutions and other types of food processing areas where fat, oil and grease (FOG) drains with the waste water. Interceptor may be installed on the ground, semi recessed or flush with the floor. Simple latch lid design permits fast and easy removal of the lid for cleaning and maintenance. HDPE injection molded body and lid is covered by a limited lifetime warranty. Sewer gas stopper prevents foul odors from entering the kitchen area through the interceptor. All Lil Max interceptors can withstand a temperature of up to and including 150° Fahrenheit.

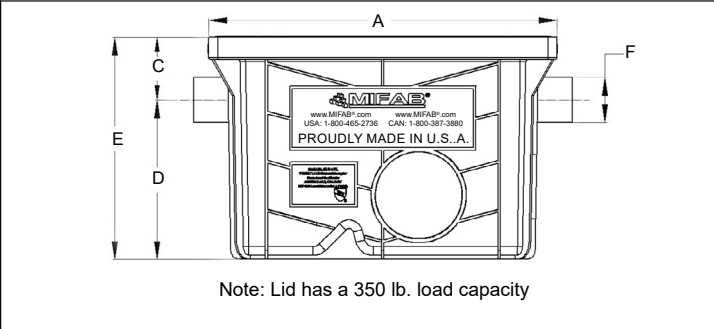
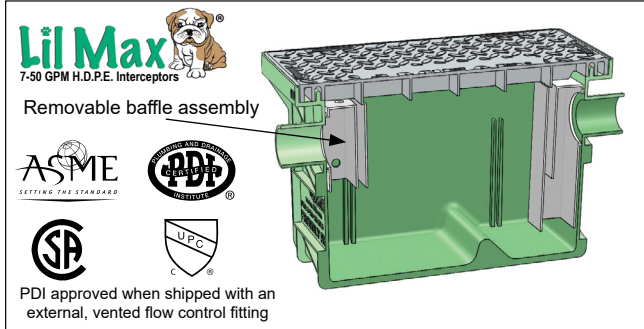

MODEL NO.	FLOW RATE (GPM)	GREASE CAP. (LBS.) per PDI	LIQUID CAP. (Gallons / Cu. Ft.)	GREASE DESIGN CAPACITY (Lbs.)	Solids Capacity (Gallons)	A (IN)	B (IN) WIDTH	C (IN)	D (IN)	E (IN)	F (IN)	Shipping Weight (lbs.) (in box)	Box Dimensions (L x W x H)
Lil-7	7	14	5.8 / .75	37	2.0	19.5	15.5	3.5	9	12.5	2	16	22" x 16" x 13"
Lil-10	10	20	9.2 / 1.2	42	2.2	23	17.5	3.5	9.75	13.25	2	25	25" x 18" x 14"
Lil-15	15	30	13 / 1.7	50	3.1	23	17.5	3.5	13.25	16.75	2	28	25" x 18" x 17.5"
Lil-20	20	40	16 / 2.1	73	3.9	29.5	20.5	3.5	10.75	14.25	3	36	32" x 21" x 15"
Lil-25	25	50	23 / 3.1	79	5.6	29.5	20.5	3.5	14.75	18.25	3	39	32" x 21" x 19"
Lil-35	35	70	39 / 5.2	86	10.6	33	25.5	5.5	16.75	22.25	3	52	35" x 26" x 23"
Lil-50	50	100	44 / 5.9	109	11.9	33	25.5	5.5	18.75	24.25	3	66	35" x 26" x 25"
Lil-25-LP	25	50	19 / 2.54	74	9.1	33	25.5	3.5	7.50	11.00	3	43	35" x 26" x 13"

SUFFIX	OPTIONAL VARIATIONS	PART NO.
-C	Extension "C" as required (up to 9" increments) (for models Lil-20 and Lil-25)	Lil-25-EXT
-C	Extension "C" as required (up to 9" increments) (for models Lil-35, Lil-50 and Lil-25-LP)	Lil-50-EXT
-DP	Dosing Pump for Lil Max, Big Max, SuperMax	XL-MI-PL-DP
-EP	Enzyme port for Lil Max, Big Max, SuperMax	XL-MI-PL-EP
-F	Connection sizes different from standard (specify size) (by using a MIFAB increasing / reducing coupling)	Contact MIFAB
-HD	Heavy duty 10 gauge stainless steel lid (up to 2,000 lbs. load bearing) (See page 28 for image)	Contact MIFAB
-HLA	High level alarm and float switch (to be installed on site) (for Lil Max, Big Max, SuperMax)	XL-MI-PL-HLA
-HLA2	High level alarm and dual float switch (to be installed on site) (for Lil Max, Big Max, SuperMax)	XL-MI-PL-HLA2
-HLAW	High level alarm and dual float switch with wifi capability (to be installed on site) (for Lil Max, Big Max, SuperMax)	XL-MI-PL-HLAW
-LHSI	No hub inlet on left hand side (not available with sediment bucket) (for Lil Max, Big Max, SuperMax)	MI-G-PL-PF4
-LHSO	No hub outlet on left hand side (not available with sediment bucket) (for Lil Max, Big Max, SuperMax)	MI-G-PL-PF4
-PDI	PDI plate and external, vented flow control fitting (to meet PDI G-101 Standard)	-PDI
-POK	Remote pump out kit	LIL-MAX-POK
-RHSI	No hub inlet on right hand side (not available with sediment bucket) (for Lil Max, Big Max, SuperMax)	MI-G-PL-PF4
-RHSO	No hub outlet on right hand side (not available with sediment bucket) (for Lil Max, Big Max, SuperMax)	MI-G-PL-PF4
-RPO	2" Remote pump outlet connections on top of interceptor - specify location and number required	LIL-MAX-RPO
-SAMPORT	External sampling port - offset	SAMPORT
-SB	Sediment bucket for Lil-7	MI-G-1-PL-PSB
-SB	Sediment bucket for Lil-10	MI-G-2-PL-PSB
-SB	Sediment bucket for Lil-15	MI-G-3-PL-PSB
-SB	Sediment bucket for Lil-20	MI-G-4-PL-PSB
-SB	Sediment bucket for Lil-25	MI-G-5-PL-PSB
-SB	Sediment bucket for Lil-35	MI-G-6-PL-PSB
-SB	Sediment bucket for Lil-50	MI-G-7-PL-PSB
-SB	Sediment bucket for Lil-25-LP	MI-G-5-PL-PSB-FSCR
-SP-IN	External sampling port - inline	Lil-SP
-SP-OFF	External sampling port - offset	Lil-SP-OFF
-T	Female threaded connections (for Lil Max, Big Max, SuperMax - 2 pcs. Included)	MI-G-PL-PF4T

CALIFORNIA PROPOSITION 65 WARNING. This product contains chemicals known to the State of California to cause cancer and birth defects or other reproductive harm.

Job Name: _____ Page No: _____
 Section No: _____ Contractor: _____
 Schedule No: _____ Purchase Order No: _____