

MiTek, Inc.  
16023 Swingley Ridge Rd.  
Chesterfield, MO 63017  
314.434.1200

Re: 25120071-A  
Altis @ Serenity Clubhouse-Clubhouse Roof

The truss drawing(s) referenced below have been prepared by MiTek USA, Inc. under my direct supervision based on the parameters provided by Carter Components (Chesapeake, VA).

Pages or sheets covered by this seal: I81448639 thru I81448641

My license renewal date for the state of Virginia is December 31, 2026.



April 28, 2026

---

Lassiter, Frank

**IMPORTANT NOTE:** The seal on these truss component designs is a certification that the engineer named is licensed in the jurisdiction(s) identified and that the designs comply with ANSI/TPI 1. These designs are based upon parameters shown (e.g., loads, supports, dimensions, shapes and design codes), which were given to MiTek or TRENCO. Any project specific information included is for MiTek's or TRENCO's customers file reference purpose only, and was not taken into account in the preparation of these designs. MiTek or TRENCO has not independently verified the applicability of the design parameters or the designs for any particular building. Before use, the building designer should verify applicability of design parameters and properly incorporate these designs into the overall building design per ANSI/TPI 1, Chapter 2.

Job 25120071-A	Truss I1	Truss Type Common	Qty 7	Ply 1	Altis @ Serenity Clubhouse-Clubhouse Roof Job Reference (optional)	I81448639
-------------------	-------------	----------------------	----------	----------	---	-----------

Carter Components (Chesapeake), Chesapeake, VA - 23323,

Run: 25.40 E Nov 25 2025 Print: 25.4.0 E Nov 25 2025 MiTek Industries, Inc. Tue Apr 28 12:47:23  
ID:cveN0elmRr6PsTbYJ1bGdSy9upj-T0HuS6mRcBw40e1SbXz1hgMx8Q8V8J8AUTaziZzMBzY

Page: 1

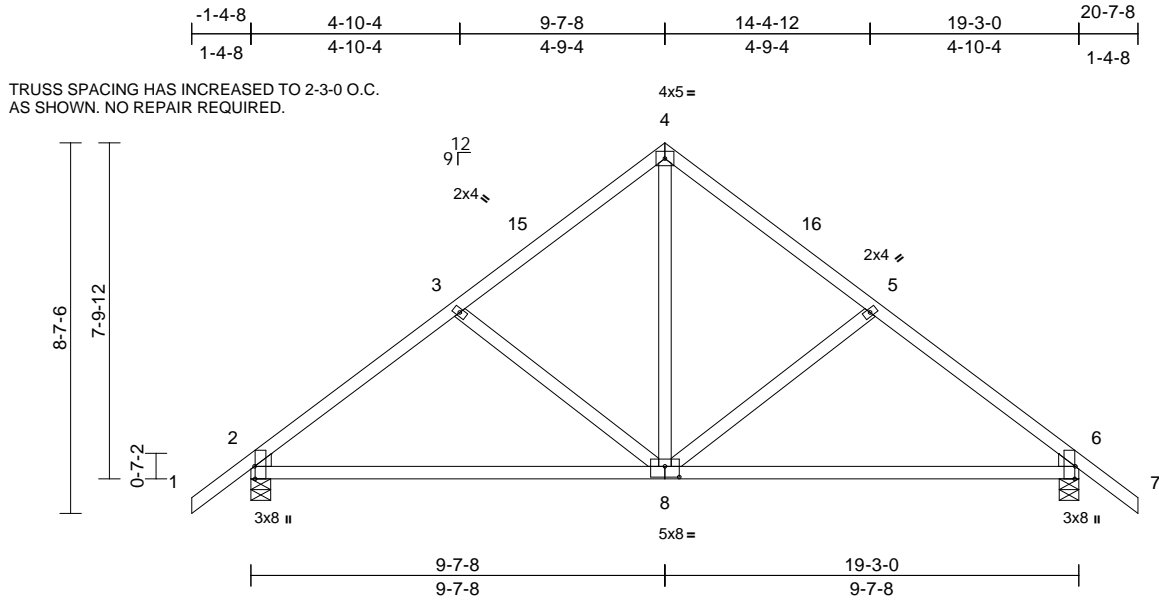

Scale = 1:53.6  
Plate Offsets (X, Y): [2:0-3-8,Edge], [6:0-3-8,Edge], [8:0-4-0,0-3-0]

Loading	(psf)	Spacing	2-3-0	CSI	DEFL	in	(loc)	l/defl	L/d	PLATES	GRIP	
TCLL (roof)	20.0	Plate Grip DOL	1.15	TC	0.38	Vert(LL)	-0.14	8-14	>999	240	MT20	244/190
Snow (Pf)	15.0	Lumber DOL	1.15	BC	0.96	Vert(CT)	-0.28	8-11	>824	180		
TCDL	10.0	Rep Stress Incr	NO	WB	0.21	Horz(CT)	0.02	6	n/a	n/a		
BCLL	0.0*	Code	IBC2021/TPI2014	Matrix-MS								
BCDL	10.0											
											Weight: 99 lb	FT = 20%

**LUMBER**  
TOP CHORD 2x4 SP No.2  
BOT CHORD 2x4 SP No.2  
WEBS 2x4 SP No.2  
WEDGE Left: 2x4 SP No.2  
Right: 2x4 SP No.2

**BRACING**  
TOP CHORD Structural wood sheathing directly applied or 5-4-15 oc purlins.  
BOT CHORD Rigid ceiling directly applied or 10-0-0 oc bracing.

**REACTIONS** (lb/size) 2=835/0-5-8, 6=835/0-5-8  
Max Horiz 2=186 (LC 13)  
Max Uplift 2=-44 (LC 14), 6=-44 (LC 15)  
Max Grav 2=959 (LC 2), 6=959 (LC 2)

**FORCES** (lb) - Maximum Compression/Maximum Tension  
TOP CHORD 1-2=0/74, 2-3=-1081/79, 3-4=-834/92,  
4-5=-834/92, 5-6=-1081/79, 6-7=0/74  
BOT CHORD 2-6=-78/835  
WEBS 4-8=-3/620, 5-8=-314/166, 3-8=-313/166

- TCLL: ASCE 7-16; Pr=20.0 psf (roof LL: Lum DOL=1.15 Plate DOL=1.15); Pf=15.0 psf (Lum DOL = 1.15 Plate DOL = 1.15); Is=1.0; Rough Cat B; Fully Exp.; Ce=0.9; Cs=1.00; Ct=1.10
- This truss has been designed for greater of min roof live load of 12.0 psf or 2.00 times flat roof load of 15.0 psf on overhangs non-concurrent with other live loads.
- This truss has been designed for a 10.0 psf bottom chord live load nonconcurrent with any other live loads.
- \* This truss has been designed for a live load of 20.0psf on the bottom chord in all areas where a rectangle 3-06-00 tall by 2-00-00 wide will fit between the bottom chord and any other members.
- One H2.5A Simpson Strong-Tie connectors recommended to connect truss to bearing walls due to UPLIFT at jt(s) 2 and 6. This connection is for uplift only and does not consider lateral forces.

**LOAD CASE(S)** Standard

- NOTES**
- Unbalanced roof live loads have been considered for this design.
  - Wind: ASCE 7-16; Vult=120mph (3-second gust) Vasd=95mph; TCDL=6.0psf; BCCL=6.0psf; h=25ft; Cat. II; Exp B; Enclosed; MWFRS (envelope) exterior zone and C-C Exterior(2E) -1-4-8 to 1-7-8, Interior (1) 1-7-8 to 9-7-8, Exterior(2R) 9-7-8 to 12-7-8, Interior (1) 12-7-8 to 20-7-8 zone; cantilever left and right exposed ; end vertical left and right exposed;C-C for members and forces & MWFRS for reactions shown; Lumber DOL=1.60 plate grip DOL=1.33



April 28, 2026

Job 25120071-A	Truss I2	Truss Type Common	Qty 8	Ply 1	Altis @ Serenity Clubhouse-Clubhouse Roof Job Reference (optional)	I81448640
-------------------	-------------	----------------------	----------	----------	---	-----------

Carter Components (Chesapeake), Chesapeake, VA - 23323,

Run: 25.40 E Nov 25 2025 Print: 25.4.0 E Nov 25 2025 MiTek Industries, Inc. Tue Apr 28 13:07:15  
ID:UyQJop?xvIIQtia2yTB\_uy9upO-aKIWdiB7uQ5y0q9YQitMZ?1jdwwzHQP8dawK2YTzMBgw

Page: 1

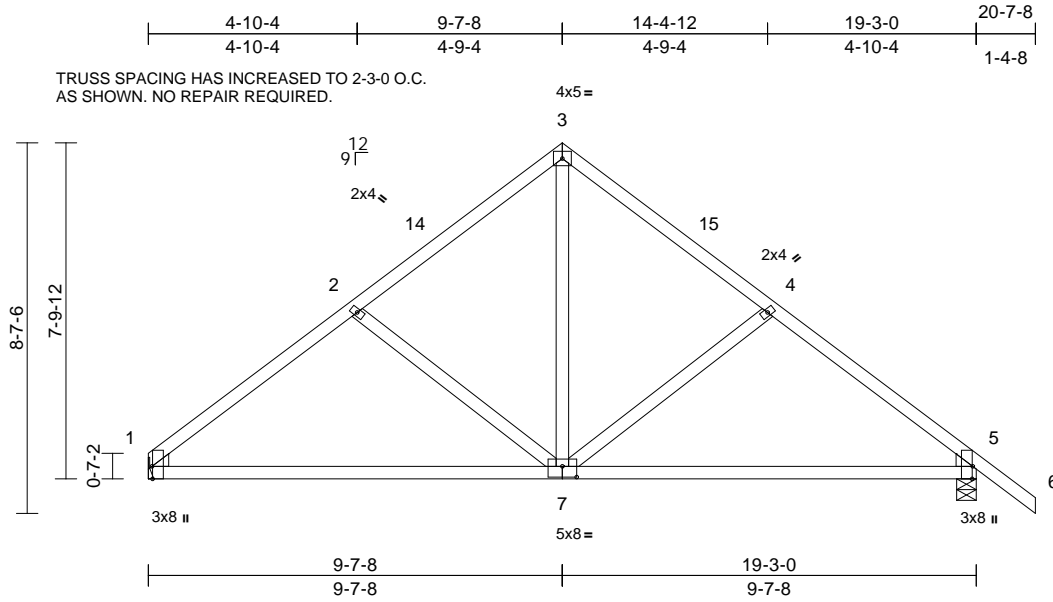

Scale = 1:53.6  
Plate Offsets (X, Y): [1:0-3-8,Edge], [5:0-3-8,Edge], [7:0-4-0,0-3-0]

Loading	(psf)	Spacing	2-3-0	CSI	DEFL	in	(loc)	l/defl	L/d	PLATES	GRIP	
TCLL (roof)	20.0	Plate Grip DOL	1.15	TC	0.41	Vert(LL)	-0.14	7-10	>999	240	MT20	244/190
Snow (Pf)	15.0	Lumber DOL	1.15	BC	0.97	Vert(CT)	-0.29	7-10	>805	180		
TCDL	10.0	Rep Stress Incr	NO	WB	0.21	Horz(CT)	0.02	5	n/a	n/a		
BCLL	0.0*	Code	IBC2021/TPI2014	Matrix-MS								
BCDL	10.0											
											Weight: 97 lb	FT = 20%

**LUMBER**  
TOP CHORD 2x4 SP No.2  
BOT CHORD 2x4 SP No.2  
WEBS 2x4 SP No.2  
WEDGE Left: 2x4 SP No.2  
Right: 2x4 SP No.2

**BRACING**  
TOP CHORD Structural wood sheathing directly applied or 5-4-13 oc purlins.  
BOT CHORD Rigid ceiling directly applied or 10-0-0 oc bracing.

**REACTIONS** (lb/size) 1=755/ Mechanical, 5=838/0-5-8  
Max Horiz 1=-178 (LC 12)  
Max Uplift 1=-20 (LC 14), 5=-44 (LC 15)  
Max Grav 1=863 (LC 2), 5=962 (LC 2)

**FORCES** (lb) - Maximum Compression/Maximum Tension  
TOP CHORD 1-2=-1075/86, 2-3=-841/97, 3-4=-840/93,  
4-5=-1087/81, 5-6=0/74  
BOT CHORD 1-5=-105/847  
WEBS 3-7=-9/623, 4-7=-313/166, 2-7=-324/170

- TCLL: ASCE 7-16; Pr=20.0 psf (roof LL: Lum DOL=1.15 Plate DOL=1.15); Pf=15.0 psf (Lum DOL = 1.15 Plate DOL = 1.15); Is=1.0; Rough Cat B; Fully Exp.; Ce=0.9; Cs=1.00; Ct=1.10
- This truss has been designed for greater of min roof live load of 12.0 psf or 2.00 times flat roof load of 15.0 psf on overhangs non-concurrent with other live loads.
- This truss has been designed for a 10.0 psf bottom chord live load nonconcurrent with any other live loads.
- \* This truss has been designed for a live load of 20.0psf on the bottom chord in all areas where a rectangle 3-06-00 tall by 2-00-00 wide will fit between the bottom chord and any other members.
- Refer to girder(s) for truss to truss connections.
- Provide mechanical connection (by others) of truss to bearing plate capable of withstanding 20 lb uplift at joint 1.
- One H2.5A Simpson Strong-Tie connectors recommended to connect truss to bearing walls due to UPLIFT at jt(s) 5. This connection is for uplift only and does not consider lateral forces.

**LOAD CASE(S)** Standard

- NOTES**
- Unbalanced roof live loads have been considered for this design.
  - Wind: ASCE 7-16; Vult=120mph (3-second gust) Vasd=95mph; TCDL=6.0psf; BCDL=6.0psf; h=25ft; Cat. II; Exp B; Enclosed; MWFRS (envelope) exterior zone and C-C Exterior(2E) 0-0-0 to 3-0-0, Interior (1) 3-0-0 to 9-7-8, Exterior(2R) 9-7-8 to 12-7-8, Interior (1) 12-7-8 to 20-7-8 zone; cantilever left and right exposed ; end vertical left and right exposed;C-C for members and forces & MWFRS for reactions shown; Lumber DOL=1.60 plate grip DOL=1.33



April 28, 2026

Job 25120071-A	Truss I3	Truss Type Common	Qty 4	Ply 1	Altis @ Serenity Clubhouse-Clubhouse Roof Job Reference (optional)	I81448641
-------------------	-------------	----------------------	----------	----------	---	-----------

Carter Components (Chesapeake), Chesapeake, VA - 23323,

Run: 25.40 E Nov 25 2025 Print: 25.4.0 E Nov 25 2025 MiTek Industries, Inc. Tue Apr 28 13:00:37  
ID:y8\_h?90ZGbtHVshmf\_QW5y9upN-EmF25cNUd8yQGgk36HDEt6EcwV99APu23?w\_aYzMBn8

Page: 1

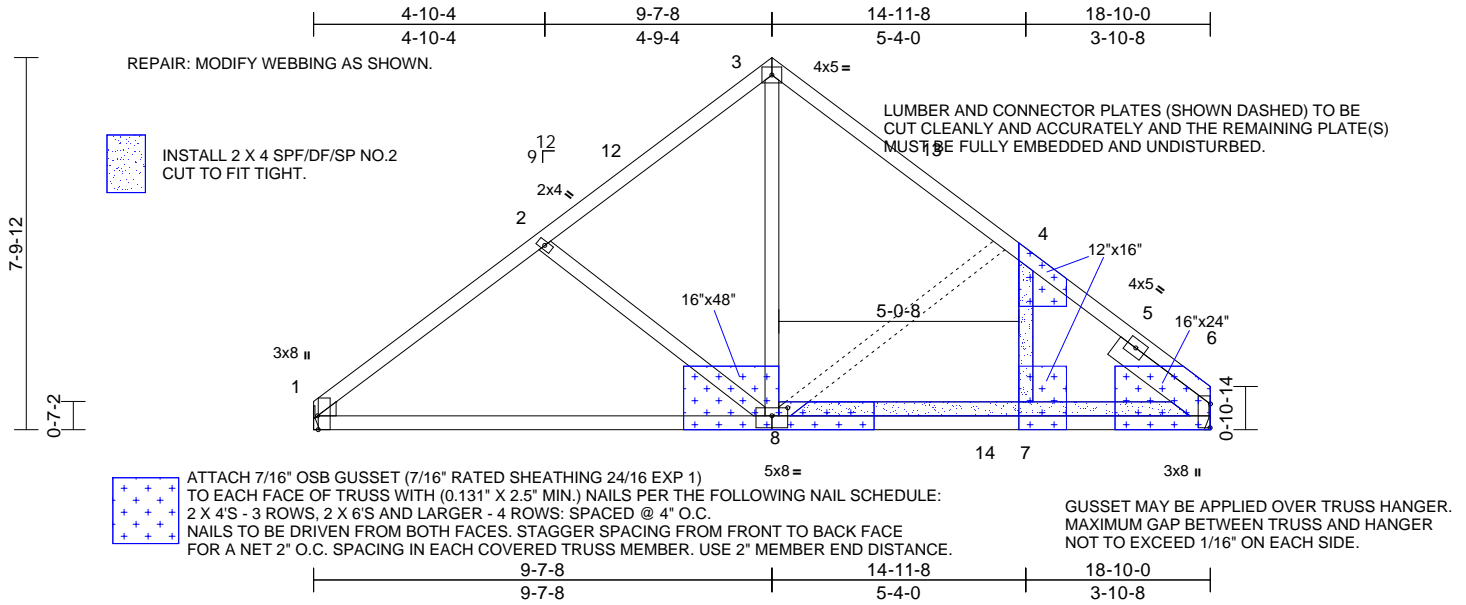

Scale = 1:48.4

Plate Offsets (X, Y): [1:0-3-8,Edge], [6:0-6-0,0-0-1], [8:0-4-0,0-2-0]

Loading	(psf)	Spacing	2-0-0	CSI	DEFL	in	(loc)	l/defl	L/d	PLATES	GRIP	
TCLL (roof)	20.0	Plate Grip DOL	1.15	TC	0.44	Vert(LL)	-0.13	8-11	>999	240	MT20	244/190
Snow (Pf)	15.0	Lumber DOL	1.15	BC	0.90	Vert(CT)	-0.26	8-11	>857	180		
TCDL	10.0	Rep Stress Incr	YES	WB	0.19	Horz(CT)	0.02	6	n/a	n/a		
BCLL	0.0*	Code	IBC2021/TPI2014	Matrix-MS								
BCDL	10.0											
											Weight: 107 lb	FT = 20%

**LUMBER**  
TOP CHORD 2x4 SP No.2  
BOT CHORD 2x4 SP No.2  
WEBS 2x4 SP No.2  
WEDGE Left: 2x4 SP No.2  
SLIDER Right 2x6 SP No.2 -- 2-6-0

**BRACING**  
TOP CHORD Structural wood sheathing directly applied or 5-7-6 oc purlins.  
BOT CHORD Rigid ceiling directly applied or 10-0-0 oc bracing.

**REACTIONS** (lb/size) 1=645/ Mechanical, 6=645/ Mechanical  
Max Horiz 1=-147 (LC 10)  
Max Uplift 1=-18 (LC 14), 6=-12 (LC 15)  
Max Grav 1=830 (LC 25), 6=843 (LC 26)

**FORCES** (lb) - Maximum Compression/Maximum Tension  
TOP CHORD 1-2=-991/81, 2-3=-820/91, 3-4=-808/85, 4-6=-861/3  
BOT CHORD 1-7=-107/871, 6-7=0/637  
WEBS 3-8=-5/620, 2-8=-296/148, 4-7=-240/182

- TCLL: ASCE 7-16; Pr=20.0 psf (roof LL: Lum DOL=1.15 Plate DOL=1.15); Pf=15.0 psf (Lum DOL = 1.15 Plate DOL = 1.15); Is=1.0; Rough Cat B; Fully Exp.; Ce=0.9; Cs=1.00; Ct=1.10
- This truss has been designed for a 10.0 psf bottom chord live load nonconcurrent with any other live loads.
- \* This truss has been designed for a live load of 20.0psf on the bottom chord in all areas where a rectangle 3-06-00 tall by 2-00-00 wide will fit between the bottom chord and any other members, with BCDL = 10.0psf.
- Refer to girder(s) for truss to truss connections.
- Provide mechanical connection (by others) of truss to bearing plate capable of withstanding 12 lb uplift at joint 6 and 18 lb uplift at joint 1.

**LOAD CASE(S)** Standard

- NOTES**
- Unbalanced roof live loads have been considered for this design.
  - Wind: ASCE 7-16; Vult=120mph (3-second gust) Vasd=95mph; TCDL=6.0psf; BCDL=6.0psf; h=25ft; Cat. II; Exp B; Enclosed; MWFRS (envelope) exterior zone and C-C Exterior(2E) 0-0-0 to 3-0-0, Interior (1) 3-0-0 to 9-7-8, Exterior(2R) 9-7-8 to 12-7-8, Interior (1) 12-7-8 to 18-5-1 zone; cantilever left and right exposed; end vertical left and right exposed; C-C for members and forces & MWFRS for reactions shown; Lumber DOL=1.60 plate grip DOL=1.33



April 28, 2026

**WARNING - Verify design parameters and READ NOTES ON THIS AND INCLUDED MITEK REFERENCE PAGE MII-7473 rev. 1/2/2023 BEFORE USE.**

Design valid for use only with MiTek® connectors. This design is based only upon parameters shown, and is for an individual building component, not a truss system. Before use, the building designer must verify the applicability of design parameters and properly incorporate this design into the overall building design. Bracing indicated is to prevent buckling of individual truss web and/or chord members only. Additional temporary and permanent bracing is always required for stability and to prevent collapse with possible personal injury and property damage. For general guidance regarding the fabrication, storage, delivery, erection and bracing of trusses and truss systems, see **ANSI/TPI1 Quality Criteria, and DSB-22** available from Truss Plate Institute (www.tpinst.org) and **BCSI Building Component Safety Information** available from the Structural Building Component Association (www.sbcsccomponents.com)

**MiTek®**

16023 Swingley Ridge Rd.  
Chesterfield, MO 63017  
314.434.1200 / MiTek-US.com

Job 25120071-A	Truss I1-2	Truss Type Common	Qty 7	Ply 1	Altis @ Serenity Clubhouse-Clubhouse Roof Job Reference (optional)	I81448639.01
-------------------	---------------	----------------------	----------	----------	---	--------------

Carter Components (Chesapeake), Chesapeake, VA - 23323,

Run: 25.40 E Nov 25 2025 Print: 25.40 E Nov 25 2025 MiTek Industries, Inc. Tue Apr 28 11:59:52

Page: 1

ID:cveNOelmRr6PsTbYJ1bGdSy9upj-SXW54FG51DjcUWw4GJTcSnhXA6yevmXuPTc9JzMcG5

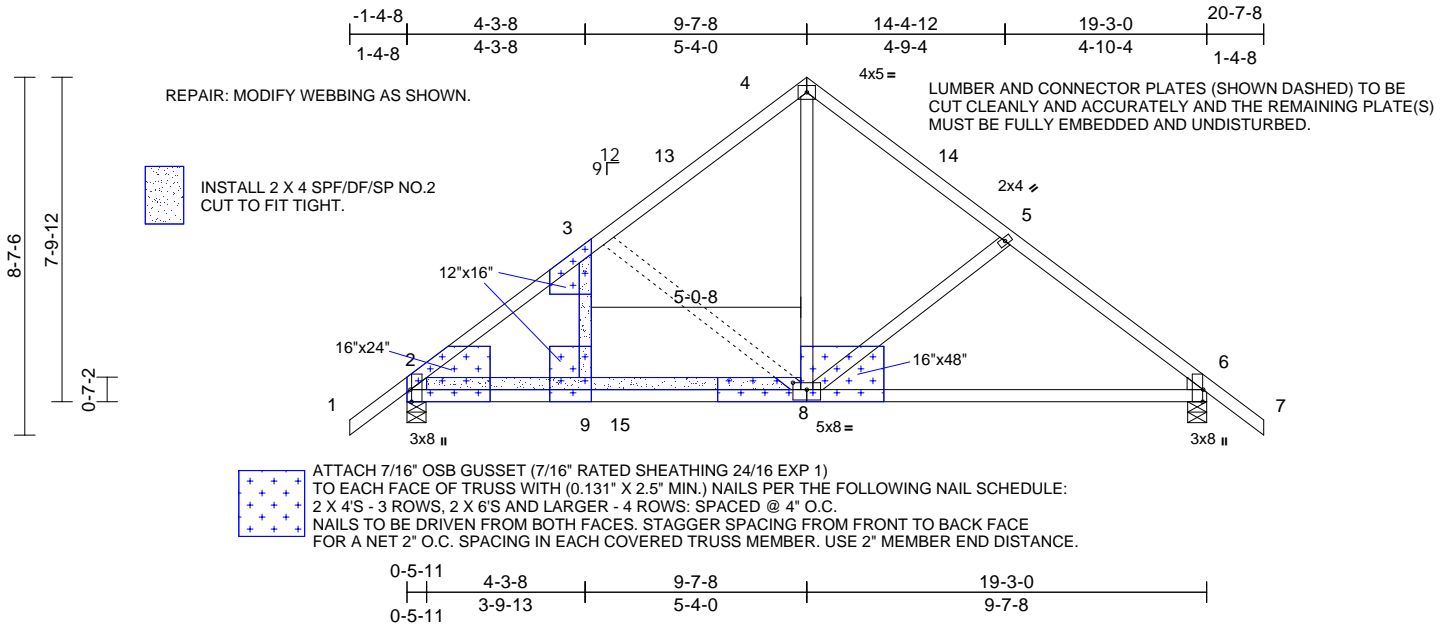

Scale = 1:55.5  
Plate Offsets (X, Y): [2:0-3-8,Edge], [6:0-3-8,Edge], [8:0-4-0,0-2-0]

Loading	(psf)	Spacing	2-0-0	CSI	DEFL	in	(loc)	l/defl	L/d	PLATES	GRIP	
TCLL (roof)	20.0	Plate Grip DOL	1.15	TC	0.45	Vert(LL)	0.16	8-9	>999	240	MT20	244/190
Snow (Pf)	15.0	Lumber DOL	1.15	BC	1.00	Vert(CT)	-0.27	8-9	>859	180		
TCDL	10.0	Rep Stress Incr	YES	WB	0.18	Horz(CT)	-0.01	6	n/a	n/a		
BCLL	0.0*	Code	IBC2021/TPI2014	Matrix-MS								
BCDL	10.0											
											Weight: 109 lb	FT = 20%

**LUMBER**  
TOP CHORD 2x4 SP No.2  
BOT CHORD 2x4 SP No.2  
WEBS 2x4 SP No.2  
WEDGE Left: 2x4 SP No.2  
Right: 2x4 SP No.2

**BRACING**  
TOP CHORD Structural wood sheathing directly applied or 5-4-12 oc purlins.  
BOT CHORD Rigid ceiling directly applied or 2-2-0 oc bracing.

**REACTIONS** (lb/size) 2=744/0-5-8, 6=739/0-5-8  
Max Horiz 2=165 (LC 13)  
Max Uplift 2=-42 (LC 14), 6=-41 (LC 15)  
Max Grav 2=962 (LC 26), 6=941 (LC 27)

**FORCES** (lb) - Maximum Compression/Maximum Tension  
TOP CHORD 1-3=-911/70, 3-4=-861/81, 4-5=-872/85,  
5-6=-1038/74, 6-7=0/66  
BOT CHORD 2-9=0/709, 6-9=-8/817  
WEBS 4-8=-1/671, 5-8=-274/145, 3-9=-265/171

- TCLL: ASCE 7-16; Pr=20.0 psf (roof LL: Lum DOL=1.15 Plate DOL=1.15); Pf=15.0 psf (Lum DOL = 1.15 Plate DOL = 1.15); Is=1.0; Rough Cat B; Fully Exp.; Ce=0.9; Cs=1.00; Ct=1.10
- This truss has been designed for greater of min roof live load of 12.0 psf or 2.00 times flat roof load of 15.0 psf on overhangs non-concurrent with other live loads.
- This truss has been designed for a 10.0 psf bottom chord live load nonconcurrent with any other live loads.
- \* This truss has been designed for a live load of 20.0psf on the bottom chord in all areas where a rectangle 3-06-00 tall by 2-00-00 wide will fit between the bottom chord and any other members, with BCDL = 10.0psf.
- Provide mechanical connection (by others) of truss to bearing plate capable of withstanding 42 lb uplift at joint 2 and 41 lb uplift at joint 6.

**LOAD CASE(S)** Standard

- NOTES**
- Unbalanced roof live loads have been considered for this design.
  - Wind: ASCE 7-16; Vult=120mph (3-second gust) Vasd=95mph; TCDL=6.0psf; BCDL=6.0psf; h=25ft; Cat. II; Exp B; Enclosed; MWFRS (envelope) exterior zone and C-C Exterior(2E) -1-4-8 to 1-7-8, Interior (1) 1-7-8 to 9-7-8, Exterior(2R) 9-7-8 to 12-7-8, Interior (1) 12-7-8 to 20-7-8 zone; cantilever left and right exposed ; end vertical left and right exposed;C-C for members and forces & MWFRS for reactions shown; Lumber DOL=1.60 plate grip DOL=1.33



April 28, 2026

Job 25120071-A	Truss I2-2	Truss Type Common	Qty 8	Ply 1	Altis @ Serenity Clubhouse-Clubhouse Roof Job Reference (optional)	181448640.01
-------------------	---------------	----------------------	----------	----------	---	--------------

Carter Components (Chesapeake), Chesapeake, VA - 23323,

Run: 25.40 E Nov 25 2025 Print: 25.4.0 E Nov 25 2025 MiTek Industries, Inc. Tue Apr 28 12:51:33  
ID:UyQJop?xVlIQia2yTB\_uy9upO-96OowboFk?Qc?38WE1SqQidsCWOJN?zzM8CU4zMBve

Page: 1

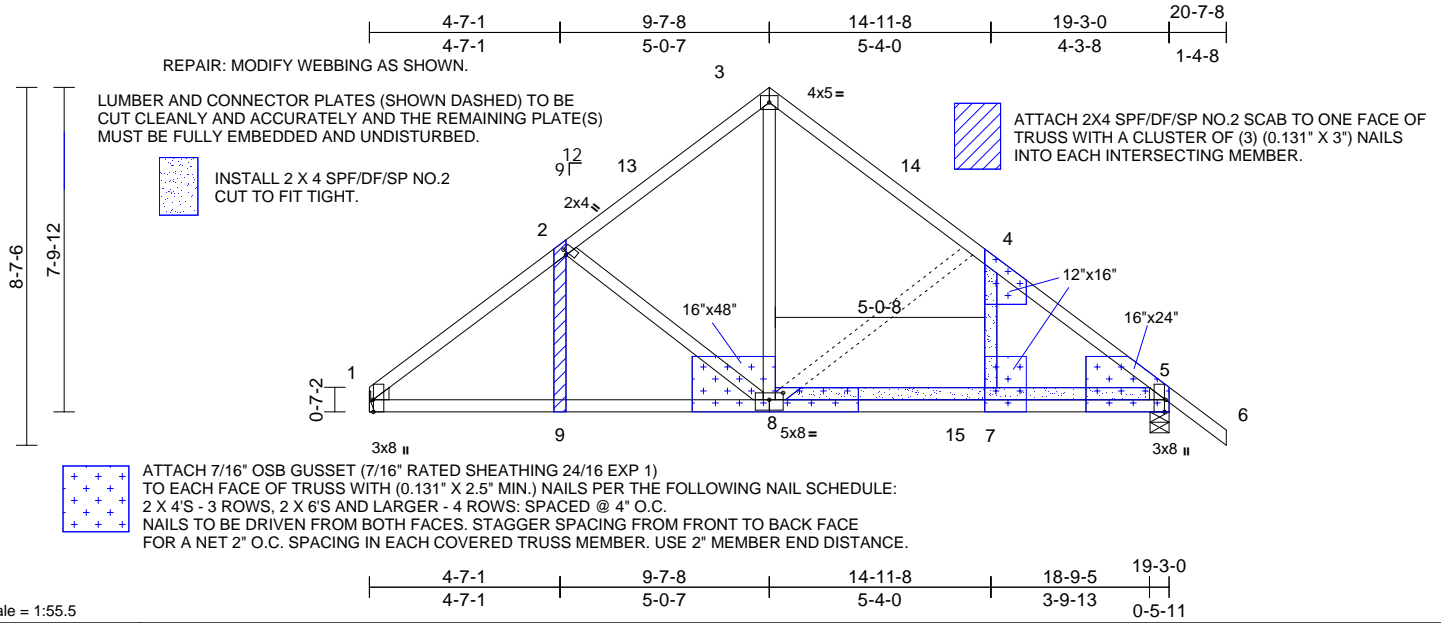

Plate Offsets (X, Y): [1:0-3-8,Edge], [2:0-1-8,0-0-12], [5:0-3-8,Edge], [8:0-4-0,0-2-0]

Loading	(psf)	Spacing	2-0-0	CSI	DEFL	in	(loc)	l/defl	L/d	PLATES	GRIP	
TCLL (roof)	20.0	Plate Grip DOL	1.15	TC	0.46	Vert(LL)	-0.16	7-8	>999	240	MT20	244/190
Snow (Pf)	15.0	Lumber DOL	1.15	BC	0.81	Vert(CT)	-0.29	7-8	>797	180		
TCDL	10.0	Rep Stress Incr	YES	WB	0.21	Horz(CT)	0.01	5	n/a	n/a		
BCLL	0.0*	Code	IBC2021/TPI2014	Matrix-MS								
BCDL	10.0											
											Weight: 111 lb	FT = 20%

**LUMBER**  
TOP CHORD 2x4 SP No.2  
BOT CHORD 2x4 SP No.2  
WEBS 2x4 SP No.2  
WEDGE Left: 2x4 SP No.2  
Right: 2x4 SP No.2

**BRACING**  
TOP CHORD Structural wood sheathing directly applied or 5-4-12 oc purlins.  
BOT CHORD Rigid ceiling directly applied or 10-0-0 oc bracing.

**REACTIONS** (lb/size) 1=668/ Mechanical, 5=747/0-5-8  
Max Horiz 1=-158 (LC 12)  
Max Uplift 1=-18 (LC 14), 5=-40 (LC 15)  
Max Grav 1=860 (LC 26), 5=962 (LC 27)

**FORCES** (lb) - Maximum Compression/Maximum Tension  
TOP CHORD 1-2=-1096/47, 2-3=-866/102, 3-4=-846/93, 4-6=-901/70  
BOT CHORD 1-9=-78/937, 7-9=-55/942, 5-7=0/693  
WEBS 3-8=-17/643, 2-8=-317/123, 4-7=-263/176, 2-9=0/123

- TCLL: ASCE 7-16; Pr=20.0 psf (roof LL: Lum DOL=1.15 Plate DOL=1.15); Pf=15.0 psf (Lum DOL = 1.15 Plate DOL = 1.15); Is=1.0; Rough Cat B; Fully Exp.; Ce=0.9; Cs=1.00; Ct=1.10
  - This truss has been designed for greater of min roof live load of 12.0 psf or 2.00 times flat roof load of 15.0 psf on overhangs non-concurrent with other live loads.
  - This truss has been designed for a 10.0 psf bottom chord live load nonconcurrent with any other live loads.
  - \* This truss has been designed for a live load of 20.0psf on the bottom chord in all areas where a rectangle 3-06-00 tall by 2-00-00 wide will fit between the bottom chord and any other members, with BCDL = 10.0psf.
  - Refer to girder(s) for truss to truss connections.
  - Provide mechanical connection (by others) of truss to bearing plate capable of withstanding 18 lb uplift at joint 1 and 40 lb uplift at joint 5.
- LOAD CASE(S)** Standard

- NOTES**
- Unbalanced roof live loads have been considered for this design.
  - Wind: ASCE 7-16; Vult=120mph (3-second gust) Vasd=95mph; TCDL=6.0psf; BCDL=6.0psf; h=25ft; Cat. II; Exp B; Enclosed; MWFRS (envelope) exterior zone and C-C Exterior(2E) 0-0-0 to 3-0-0, Interior (1) 3-0-0 to 9-7-8, Exterior(2R) 9-7-8 to 12-7-8, Interior (1) 12-7-8 to 20-7-8 zone; cantilever left and right exposed; end vertical left and right exposed; C-C for members and forces & MWFRS for reactions shown; Lumber DOL=1.60 plate grip DOL=1.33



April 28, 2026

# Symbols

## PLATE LOCATION AND ORIENTATION

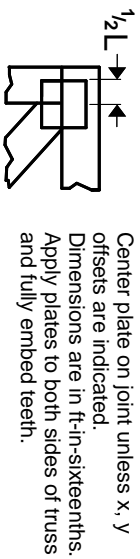

Center plate on joint unless x, y offsets are indicated. Dimensions are in ft-in-sixteenths. Apply plates to both sides of truss and fully embed teeth.

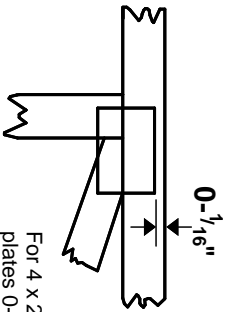

For 4 x 2 orientation, locate plates 0- 1/16\"/>



This symbol indicates the required direction of slots in connector plates.

\* Plate location details available in MITtek software or upon request.

## PLATE SIZE

4 X 4

The first dimension is the plate width measured perpendicular to slots. Second dimension is the length parallel to slots.

## LATERAL BRACING LOCATION



Indicated by symbol shown and/or by text in the bracing section of the output. Use T or I bracing if indicated.

## BEARING

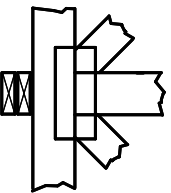

Indicates location where bearings (supports) occur. Icons vary but reaction section indicates joint number/letter where bearings occur. Min size shown is for crushing only.

## Industry Standards:

ANSI/TFP1: National Design Specification for Metal Plate Connected Wood Truss Construction.  
 DSB-22: Design Standard for Bracing.  
 BCSI: Building Component Safety Information, Guide to Good Practice for Handling, Installing, Restraining & Bracing of Metal Plate Connected Wood Trusses.

# Numbering System

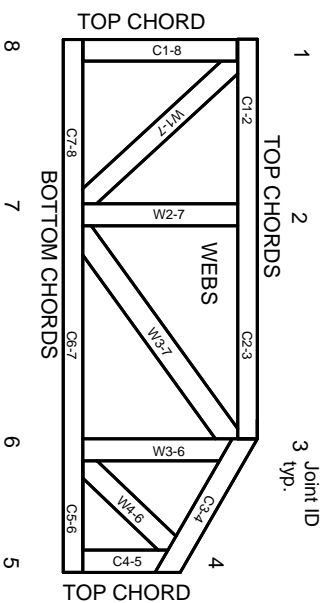

JOINTS ARE GENERALLY NUMBERED/LETTERED CLOCKWISE AROUND THE TRUSS STARTING AT THE JOINT FARTHEST TO THE LEFT.

CHORDS AND WEBS ARE IDENTIFIED BY END JOINT NUMBERS/LETTERS.

## Product Code Approvals

ICC-ES Reports:

ESR-1-1988, ESR-2-362, ESR-2-685, ESR-3-282  
 ESR-4-722, ESL-1-388

## Design General Notes

Trusses are designed for wind loads in the plane of the truss unless otherwise shown.

Lumber design values are in accordance with ANSI/TFP 1 section 6.3. These truss designs rely on Lumber values established by others.

© 2023 MITtek® All Rights Reserved

# General Safety Notes

## Failure to Follow Could Cause Property Damage or Personal Injury

1. Additional stability/bracing for truss system, e.g. diagonal or X-bracing, is always required. See BCSI.
2. Truss bracing must be designed by an engineer. For wide truss spacing, individual lateral braces themselves may require bracing, or alternative Tor I bracing should be considered.
3. Never exceed the design loading shown and never stack materials on inadequately braced trusses.
4. Provide copies of this truss design to the building designer, erection supervisor, property owner and all other interested parties.
5. Cut members to bear tightly against each other.
6. Place plates on each face of truss at each joint and embed fully. Knots and wane at joint locations are regulated by ANSI/TFP 1.
7. Design assumes trusses will be suitably protected from the environment in accord with ANSI/TFP 1.
8. Unless otherwise noted, moisture content of lumber shall not exceed 19% at time of fabrication.
9. Unless expressly noted, this design is not applicable for use with fire retardant, preservative treated, or green lumber.
10. Camber is a non-structural consideration and is the responsibility of truss fabricator. General practice is to camber for dead load deflection.
11. Plate type, size, orientation and location dimensions indicated are minimum plating requirements.
12. Lumber used shall be of the species and size, and in all respects, equal to or better than that specified.
13. Top chords must be sheathed or purlins provided at spacing indicated on design.
14. Bottom chords require lateral bracing at 10 ft. spacing, or less, if no ceiling is installed, unless otherwise noted.
15. Connections not shown are the responsibility of others.
16. Do not cut or alter truss member or plate without prior approval of an engineer.
17. Install and load vertically unless indicated otherwise.
18. Use of green or treated lumber may pose unacceptable environmental, health or performance risks. Consult with project engineer before use.
19. Review all portions of this design (front, back, words and pictures) before use. Reviewing pictures alone is not sufficient.
20. Design assumes manufacture in accordance with ANSI/TFP 1 Quality Criteria.
21. The design does not take into account any dynamic or other loads other than those expressly stated.



MITtek Engineering Reference Sheet: Mill-7473 rev. 1/2/2023