

SUBMITTAL DATA
PREPARED FOR:

ALTIS SERENITY
325 STREAMSIDE TERRACE
FUQUAY-VARINA NC

PREPARED BY:
J & D SPRINKLER CO.
315 W.MAIN STREET
CLAYTON,
NC 27520

PH: (919)-553-2356
FAX:(919)-359-0622

HYDRAULIC CALCULATIONS

Hydrant Flow Test Report

Test Date 12/18/2025

Test Time 9:52 AM

Location

Corner of Streamside Terrace and Tranquility
Way Fuquay Varina NC

Tested by

J & D Sprinkler Co.

Notes

Test conducted by Bob Weaver and Travis Curry with
J&D Sprinkler Co. and witnessed by Harnett County
Water department

Read Hydrant

101.8 psi **static pressure**
64.9 psi **residual pressure**
hydrant elevation

Flow Hydrant(s)

Outlet	Elev	Size	C	Pitot Pressure	Flow
#1		2.5	.9	33	969 gpm

Flow Graph

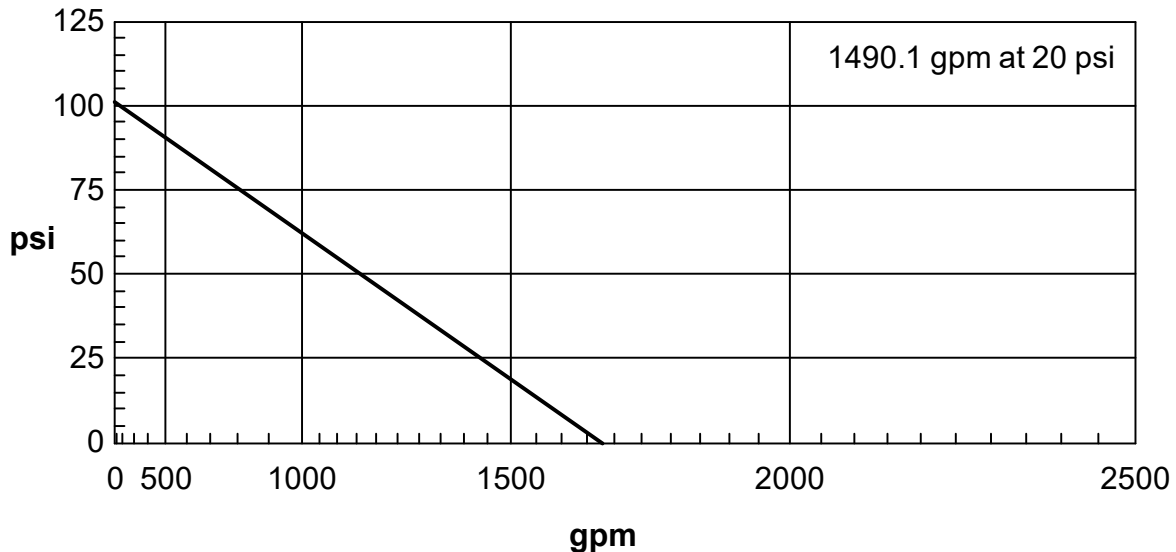

Hydraulic Overview

Job Number: BW25327
Report Description: Light Hazard (1)

Job	
Job Number BW25327	Designer TWC
Job Name: ALTIS SERENITY CLUBHOUSE	Phone 919-553-2356
Address 1 325 STREAMSIDE TERRACE	State Certification/License Number 16269FS
Address 2 FUQUAY-VARINA, NC 27526	AHJ
Address 3	Job Site/Building

System	
Density 0.10gpm/ft²	Area of Application 1500ft² (Actual 2560ft²)
Most Demanding Sprinkler Data 5.6 K-Factor 22.50 at 16.143	Hose Streams 100.00
Coverage Per Sprinkler 225ft²	Number Of Sprinklers Calculated 27
System Pressure Demand 53.104	Number Of Nozzles Calculated 0
Total Demand 739.79 @ 53.104	System Flow Demand 639.79
	Pressure Result +26.299 (33.1%)

Supplies						Check Point Gauges			
Node	Name	Flow(gpm)	Hose Flow(gpm)	Static(psi)	Residual(psi)	Identifier	Pressure(psi)	K-Factor(K)	Flow(gpm)
14	Water Supply	969.00	100.00	101.800	64.900	BOR (12)	34.660	108.67	639.79

Altis Fire Sprinkler Uprights **Water Supply at Node 14 (969.00, 0.00, 101.800, 64.900)**

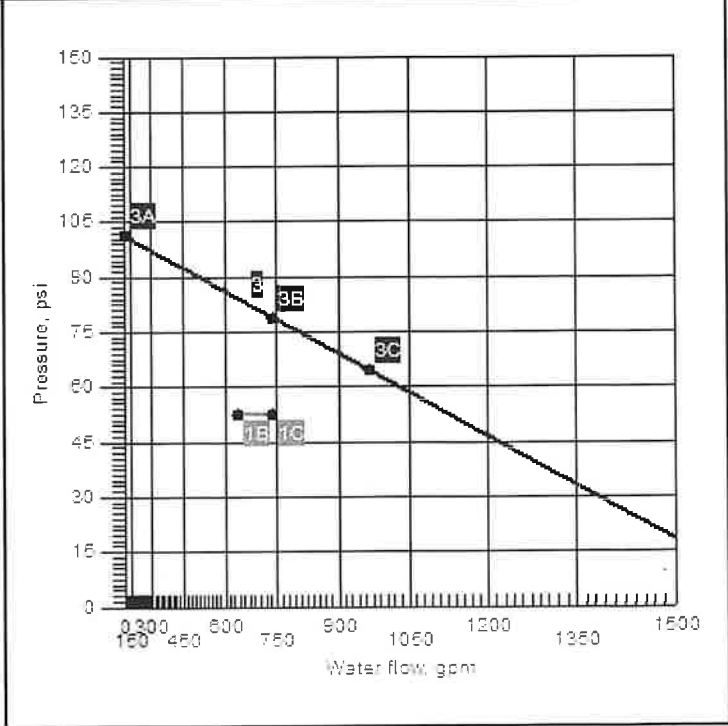
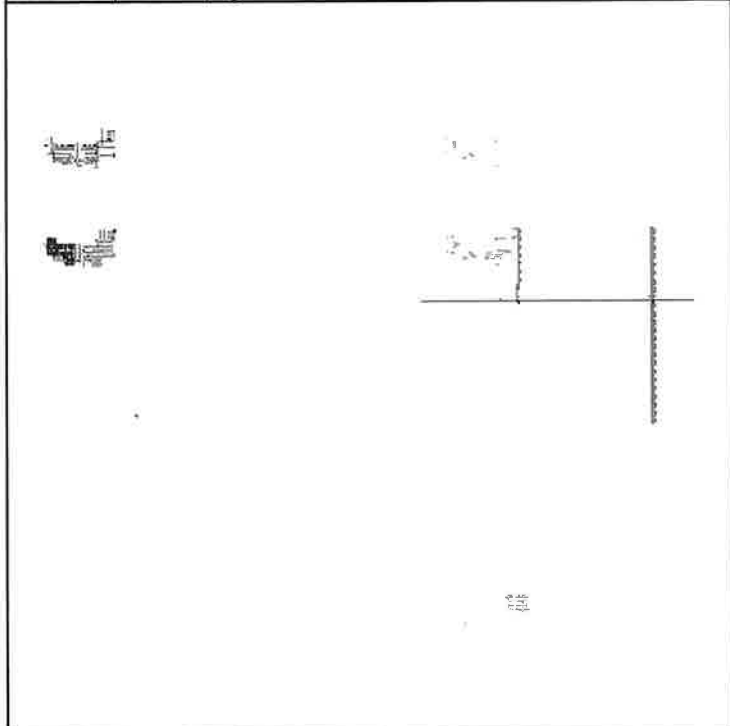

Hydraulic Calculations

for

Project Name: ALTIS SERENITY CLUBHOUSE: (BW25327)
Location: 325 STREAMSIDE TERRACE, FUQUAY-VARINA, NC 27526,
Drawing Name: Altis Fire Sprinkler Uprights

Calculation Date: 2/16/2026

Design

Remote Area Number: 1

Occupancy Classification: Light Hazard

Density 0.10gpm/ft²
Area of Application: 1500ft² (Actual 2560ft²)
Coverage per Sprinkler: 225ft²
Type of sprinklers calculated: Pendent
No. of sprinklers calculated: 27
No. of nozzles calculated: 0

In-rack Demand: N/A gpm at Node: N/A
Hose Streams: 100.00 at Node: 14 Type: Allowance at Source

Total Water Required (including Hose Streams where applicable):
From Water Supply at Node 14: 739.79 @ 53.104 (Safety Margin = 26.299)

Type of System:
Volume of Dry/PreAction/Antifreeze/OtherAgent System: 699.91gal

Name of Contractor:
Address:
Phone Number:
Name of designer: TWC
Authority Having Jurisdiction:

Notes:

Summary Notes:

Water Supply at Node 14



System Demand
Available Water Supply

Job Name: ALTIS SERENITY CLUBHOUSE
Job Number: BW25327
Report Description: Light Hazard (1)
Remote Area Number: 1

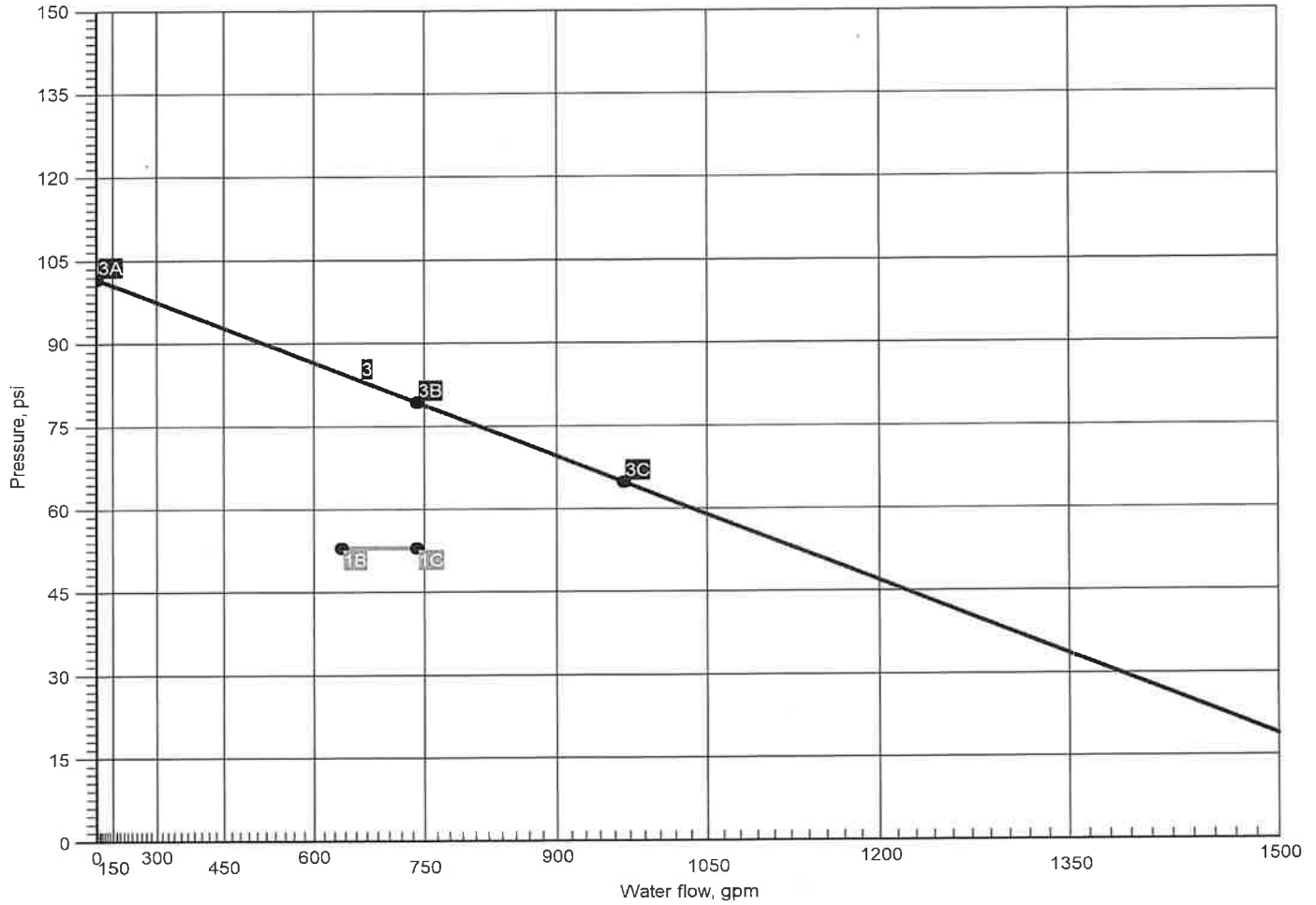

Curve	Data Point	Hydraulic Calculation Results	Additional Data
1	1B 1C	Required Pressure at System Demand: 53.104 @ 639.79 Required Pressure at System Demand (Including Hose Allowance at Source): 53.104 @ 739.79	Available Flow @ 20 PSI: 1489.42
3	3A 3B 3C	Available Static Pressure at Water Supply at Node 14: 101.800 Available Residual Pressure at System Demand: 79.404 @ 739.79 Available Residual Pressure & Flow at Water Supply at Node 14: 64.900 @ 969.00	

Summary Of Outflowing Devices

Device	Actual Flow (gpm)	Minimum Flow (gpm)	K-Factor (K)	Pressure (psi)			
⇒ Sprinkler 101	22.50	22.50	5.6	16.143			
Sprinkler 102	22.59	22.50	5.6	16.273			
Sprinkler 103	22.68	22.50	5.6	16.400			
Sprinkler 104	22.75	22.50	5.6	16.507			
Sprinkler 105	22.77	22.50	5.6	16.532			
Sprinkler 106	22.84	22.50	5.6	16.640			
Sprinkler 107	22.89	22.50	5.6	16.700			
Sprinkler 108	22.93	22.50	5.6	16.770			
Sprinkler 109	22.95	22.50	5.6	16.789			
Sprinkler 110	22.96	22.50	5.6	16.817			
Sprinkler 111	22.97	22.50	5.6	16.826			
Sprinkler 112	23.06	22.50	5.6	16.954			
Sprinkler 114	23.15	22.50	5.6	17.091			
Sprinkler 115	23.44	22.50	5.6	17.519			
Sprinkler 116	23.96	22.50	5.6	18.311			
Sprinkler 117	23.98	22.50	5.6	18.333			
Sprinkler 118	24.03	22.50	5.6	18.418			
Sprinkler 119	24.10	22.50	5.6	18.518			
Sprinkler 120	24.11	22.50	5.6	18.531			
Sprinkler 121	24.31	22.50	5.6	18.840			
Sprinkler 122	24.52	22.50	5.6	19.178			
Sprinkler 123	24.61	22.50	5.6	19.308			
Sprinkler 124	24.89	22.50	5.6	19.752			
Sprinkler 125	25.05	22.50	5.6	20.016			
Sprinkler 126	25.15	22.50	5.6	20.175			
Sprinkler 127	25.09	22.50	5.6	20.075			
Sprinkler 128	25.51	22.50	5.6	20.745			

⇒ Most Demanding Sprinkler Data

Supply Analysis							
Node	Name	Static (psi)	Residual (psi) @	Flow (gpm)	Available (psi) @	Total Demand (gpm)	Required Pressure (psi)
14	Water Supply	101.800	64.900	969.00	79.404	739.79	53.104
Node Analysis							
Node Number	Elevation (Foot)	Node Type	Pressure at Node (psi)	Discharge at Node (gpm)	Notes		
14	-3'-0	Supply	53.104	639.79			
101	15'-7	Sprinkler	16.143	22.50			
102	15'-7	Sprinkler	16.273	22.59			
103	15'-7	Sprinkler	16.400	22.68			
104	15'-7	Sprinkler	16.507	22.75			
105	15'-7	Sprinkler	16.532	22.77			
106	15'-7	Sprinkler	16.640	22.84			
107	17'-3	Sprinkler	16.700	22.89			
108	10'-1	Sprinkler	16.770	22.93			
109	10'-1	Sprinkler	16.789	22.95			
110	15'-7	Sprinkler	16.817	22.96			
111	10'-1	Sprinkler	16.826	22.97			
112	15'-7	Sprinkler	16.954	23.06			
114	10'-1	Sprinkler	17.091	23.15			
115	10'-1	Sprinkler	17.519	23.44			
116	12'-1	Sprinkler	18.311	23.96			
117	12'-1	Sprinkler	18.333	23.98			
118	10'-1	Sprinkler	18.418	24.03			

Node Number	Elevation (Foot)	Node Type	Pressure at Node (psi)	Discharge at Node (gpm)	Notes
119	10'-1	Sprinkler	18.518	24.10	
120	12'-1	Sprinkler	18.531	24.11	
121	10'-1	Sprinkler	18.840	24.31	
122	10'-1	Sprinkler	19.178	24.52	
123	10'-1	Sprinkler	19.308	24.61	
124	12'-1	Sprinkler	19.752	24.89	
125	12'-1	Sprinkler	20.016	25.05	
126	12'-1	Sprinkler	20.175	25.15	
127	10'-1	Sprinkler	20.075	25.09	
128	12'-1	Sprinkler	20.745	25.51	
1	17'-10		17.546	0.00	
2	17'-10		17.838	0.00	
3	17'-10		18.467	0.00	
4	13'-0		22.595	0.00	
5	13'-0		22.601	0.00	
6	13'-0		22.656	0.00	
7	13'-0		23.364	0.00	
8	13'-0		23.369	0.00	
9	13'-0		23.530	0.00	
10	13'-0		23.535	0.00	
11	3'-10		33.442	0.00	
12	1'-1	Gauge	34.660	0.00	BOR

Node Number	Elevation (Foot)	Node Type	Pressure at Node (psi)	Discharge at Node (gpm)	Notes
13	-3'-0		52.952	0.00	
15	17'-10		17.691	0.00	
16	17'-10		17.986	0.00	
17	17'-10		18.309	0.00	
18	13'-0		22.580	0.00	
19	13'-0		22.581	0.00	
20	13'-0		22.584	0.00	
21	17'-10		17.465	0.00	
22	17'-10		17.609	0.00	
23	13'-0		18.480	0.00	
24	13'-0		18.599	0.00	
25	13'-0		18.908	0.00	
26	13'-0		19.353	0.00	
27	13'-0		20.717	0.00	
28	13'-0		22.106	0.00	
29	13'-0		22.188	0.00	
30	13'-0		18.416	0.00	
31	13'-0		20.631	0.00	
32	13'-0		20.399	0.00	
33	13'-0		20.065	0.00	
34	13'-0		20.433	0.00	
35	13'-0		20.967	0.00	

Node Number	Elevation (Foot)	Node Type	Pressure at Node (psi)	Discharge at Node (gpm)	Notes
36	13'-0		19.990	0.00	
37	13'-0		20.329	0.00	

Pipe Information									
Node 1	Elev 1 (Foot)	K-Factor	Flow added this step (q)	Nominal ID	Fittings & Devices	Length (Foot)	C Factor	Total(Pt)	Notes Fitting/Device (Equivalent Length) Fixed Pressure Losses, when applicable, are added directly to (Pf) and shown as a negative value.
Node 2	Elev 2 (Foot)		Total Flow (Q)	Actual ID	Equiv. Length (Foot)	Fitting (Foot)	Pf Friction Loss Per Unit (psi)	Elev(Pe)	
						Total (Foot)		Friction(Pf)	
101	15'-7	5.6	22.50	1	(See Notes)	4'-1	100	16.143	••••• Route 1 ••••• Sprinkler, 2E(1'-5), PO(3'-7)
1	17'-10		22.50	1.0490		6'-5	0.226725	-0.980	
						10'-6		2.383	
1	17'-10		22.75	2		11'-10	100	17.546	Flow (q) from Route 4
2	17'-10		45.25	2.1570		11'-10	0.024673	0.292	
2	17'-10		22.68	2		12'-0½	100	17.838	Flow (q) from Route 3
3	17'-10		67.93	2.1570		12'-0½	0.052313	0.629	
3	17'-10		23.06	2	(See Notes)	9'-5	100	18.467	Flow (q) from Route 12 E(4'-4½), PO(8'-9½)
4	13'-0		90.99	2.1570		13'-2	0.089828	2.099	
						22'-7		2.029	
4	13'-0		139.14	6		2'-4	100	22.595	Flow (q) from Route 2
5	13'-0		230.13	6.3570		2'-4	0.002588	0.006	
5	13'-0		237.01	6		5'-8½	100	22.601	Flow (q) from Route 8
6	13'-0		467.14	6.3570		5'-8½	0.009589	0.055	
6	13'-0		72.05	6	(See Notes)	44'-1	100	22.656	Flow (q) from Route 15 E(12'-6½)
7	13'-0		539.19	6.3570		12'-6½	0.012503		
						56'-7½		0.708	
7	13'-0		25.05	6		0'-4	100	23.364	Flow (q) from Route 24
8	13'-0		564.24	6.3570		0'-4	0.013599	0.005	
8	13'-0		25.15	6		10'-11	100	23.369	Flow (q) from Route 26
9	13'-0		589.40	6.3570		10'-11	0.014742	0.161	
9	13'-0		25.51	6		0'-4	100	23.530	Flow (q) from Route 27
10	13'-0		614.90	6.3570		0'-4	0.015944	0.005	
10	13'-0		24.89	6	(See Notes)	198'-4	100	23.535	Flow (q) from Route 23 11E(12'-6½), DPV, BV(8'-11½)
						147'-0½	0.017158	3.981	
11	3'-10		639.79	6.3570		345'-4		5.925	

Pipe Information

Pipe Information									
Node 1	Elev 1 (Foot)	K-Factor	Flow added this step (q)	Nominal ID	Fittings & Devices	Length (Foot)	C Factor	Total(Pt)	Notes Fitting/Device (Equivalent Length) Fixed Pressure Losses, when applicable, are added directly to (Pf) and shown as a negative value.
Node 2	Elev 2 (Foot)		Total Flow (Q)	Actual ID	Equiv. Length (Foot)	Fitting (Foot)	Pf Friction Loss Per Unit (psi)	Elev(Pe)	
						Total (Foot)		Friction(Pf)	
11	3'-10			6	(See Notes)	2'-9	120	33.442	BOR
12	1'-1		639.79	6.3570		2'-9	0.012246	1.185	
								0.033	
12	1'-1			6	(See Notes)	202'-10½	140	34.660	5E(22'-1), BFP(-13.000), T(47'-3½)
13	-3'-0		639.79	6.2800		157'-7	0.009770	1.770	
						360'-5½		16.522	
13	-3'-0			12	Supply (See Notes)	340'-0	140	52.952	Avl. Pressure @ Supply: 79.404 S, C(98'-3½)
14	-3'-0		639.79	12.4600		98'-3½	0.000347		
						438'-3½		0.152	
			100.00					53.104	Hose Allowance At Source
14			739.79						Total(Pt) Route 1
102	15'-7	5.6	22.59	1	(See Notes)	4'-1	100	16.273	••••• Route 2 ••••• Sprinkler, 2E(1'-5), PO(3'-7)
15	17'-10		22.59	1.0490		6'-5	0.228416	-0.985	
						10'-6½		2.403	
15	17'-10		22.84	2		11'-10	100	17.691	Flow (q) from Route 6
16	17'-10		45.43	2.1570		11'-10	0.024857	0.294	
16	17'-10		22.77	2		6'-1½	100	17.986	Flow (q) from Route 5
17	17'-10		68.20	2.1570		6'-1½	0.052702	0.323	
17	17'-10		22.96	2	(See Notes)	15'-4	100	18.309	Flow (q) from Route 10 2E(4'-4½)
18	13'-0		91.17	2.1570		8'-9½	0.090157	2.099	
						24'-1		2.172	
18	13'-0			6		1'-5½	100	22.580	Flow (q) from Route 25
19	13'-0		91.17	6.3570		1'-5½	0.000467	0.001	
19	13'-0		25.09	6		4'-0	100	22.581	Flow (q) from Route 7
20	13'-0		116.26	6.3570		4'-0	0.000732	0.003	
20	13'-0		22.89	6		11'-6½	100	22.584	Flow (q) from Route 7
4	13'-0		139.14	6.3570		11'-6½	0.001020	0.012	

Pipe Information

Node 1	Elev 1 (Foot)	K-Factor	Flow added this step (q)	Nominal ID	Fittings & Devices	Length (Foot)	C Factor	Total(Pt)	Notes
Node 2	Elev 2 (Foot)		Total Flow (Q)	Actual ID	Equiv. Length (Foot)	Fitting (Foot)	Pf Friction Loss Per Unit (psi)		Fixed Pressure Losses, when applicable, are added directly to (Pf) and shown as a negative value.
								22.595	Total(Pt) Route 2
103	15'-7	5.6	22.68	1	(See Notes)	4'-1	100	16.400 Route 3 Sprinkler, 2E(1'-5), PO(3'-7)
						6'-5	0.230060	-0.980	
2	17'-10		22.68	1.0490		10'-6		2.418	
								17.838	Total(Pt) Route 3
104	15'-7	5.6	22.75	1	(See Notes)	4'-1	100	16.507 Route 4 Sprinkler, 3E(1'-5)
						4'-3½	0.231445	-0.980	
21	17'-10		22.75	1.0490		8'-4½		1.938	
21	17'-10			2		11'-10	100	17.465	
1	17'-10		22.75	2.1570		11'-10	0.006915	0.082	
								17.546	Total(Pt) Route 4
105	15'-7	5.6	22.77	1	(See Notes)	4'-1½	100	16.532 Route 5 Sprinkler, 2E(1'-5), PO(3'-7)
						6'-5	0.231776	-0.985	
16	17'-10		22.77	1.0490		10'-6½		2.439	
								17.986	Total(Pt) Route 5
106	15'-7	5.6	22.84	1	(See Notes)	4'-1	100	16.640 Route 6 Sprinkler, 3E(1'-5)
						4'-3½	0.233167	-0.985	
22	17'-10		22.84	1.0490		8'-4½		1.954	
22	17'-10			2		11'-10	100	17.609	
15	17'-10		22.84	2.1570		11'-10	0.006966	0.082	
								17.691	Total(Pt) Route 6
107	17'-3	5.6	22.89	1	(See Notes)	10'-10	100	16.700 Route 7 Sprinkler, 2E(1'-5), PO(3'-7)
						6'-5	0.233955	1.846	
20	13'-0		22.89	1.0490		17'-3		4.037	
								22.584	Total(Pt) Route 7
108	10'-1	5.6	22.93	1	(See Notes)	6'-3	100	16.770 Route 8 Sprinkler, 2E(1'-5), PO(3'-7)
						6'-5	0.234855	-1.264	
23	13'-0		22.93	1.0490		12'-8		2.975	
23	13'-0		22.95	2		4'-8½	100	18.480	Flow (q) from Route 9
24	13'-0		45.88	2.1570		4'-8½	0.025308	0.119	

Pipe Information

Node 1	Elev 1 (Foot)	K-Factor	Flow added this step (q)	Nominal ID	Fittings & Devices	Length (Foot)	C Factor	Total(Pt)	Notes
Node 2	Elev 2 (Foot)		Total Flow (Q)	Actual ID	Equiv. Length (Foot)	Fitting (Foot)	Pf Friction Loss Per Unit (psi)	Friction(Pf)	
24	13'-0		22.97	2		5'-9	100	18.599	Flow (q) from Route 11
25	13'-0		68.85	2.1570		5'-9	0.053629	0.309	
25	13'-0		23.15	2		4'-10	100	18.908	Flow (q) from Route 13
26	13'-0		92.00	2.1570		4'-10	0.091685	0.444	
26	13'-0		23.44	2		9'-9½	100	19.353	Flow (q) from Route 14
27	13'-0		115.44	2.1570		9'-9½	0.139523	1.364	
27	13'-0		24.52	2	(See Notes)	2'-7	100	20.717	Flow (q) from Route 21 E(4'-4½)
28	13'-0		139.96	2.1570		4'-4½	0.199257	1.389	
28	13'-0			4		6'-11½			
28	13'-0			4		11'-4½	100	22.106	
29	13'-0		139.96	4.2600		11'-4½	0.007245	0.082	
29	13'-0		97.05	4	(See Notes)	2'-9	100	22.188	Flow (q) from Route 17 T(18'-9½)
5	13'-0		237.01	4.2600		18'-9½	0.019197	0.413	
						21'-6½			
								22.601	Total(Pt) Route 8
109	10'-1	5.6	22.95	1	(See Notes)	5'-10½	100	16.789	***** Route 9 ***** Sprinkler, 2E(1'-5), PO(3'-7)
30	13'-0		22.95	1.0490		6'-5	0.235100	-1.264	
30	13'-0			2		12'-3½		2.891	
30	13'-0			2		9'-2½	100	18.416	
23	13'-0		22.95	2.1570		9'-2½	0.007024	0.065	
								18.480	Total(Pt) Route 9
110	15'-7	5.6	22.96	1	(See Notes)	4'-1½	100	16.817	***** Route 10 ***** Sprinkler, 2E(1'-5), PO(3'-7)
17	17'-10		22.96	1.0490		6'-5	0.235463	-0.986	
						10'-6½		2.478	
								18.309	Total(Pt) Route 10
111	10'-1	5.6	22.97	1	(See Notes)	6'-5½	100	16.826	***** Route 11 ***** Sprinkler, 2E(1'-5), PO(3'-7)
24	13'-0		22.97	1.0490		6'-5	0.235585	-1.264	
						12'-10½		3.038	

Pipe Information

Node 1	Elev 1 (Foot)	K-Factor	Flow added this step (q)	Nominal ID	Fittings & Devices	Length (Foot)	C Factor	Total(Pt)	Notes Fitting/Device (Equivalent Length) Fixed Pressure Losses, when applicable, are added directly to (Pf) and shown as a negative value.
Node 2	Elev 2 (Foot)		Total Flow (Q)	Actual ID	Equiv. Length (Foot)	Fitting (Foot)	Pf Friction Loss Per Unit (psi)	Elev(Pe)	
								Friction(Pf)	
								18.599	Total(Pt) Route 11
112	15'-7	5.6	23.06	1	(See Notes)	4'-1	100	16.954 Route 12 Sprinkler, 2E(1'-5), PO(3'-7)
						6'-5	0.237237	-0.980	
3	17'-10		23.06	1.0490		10'-6		2.493	
								18.467	Total(Pt) Route 12
114	10'-1	5.6	23.15	1	(See Notes)	6'-5½	100	17.091 Route 13 Sprinkler, 2E(1'-5), PO(3'-7)
						6'-5	0.239012	-1.264	
25	13'-0		23.15	1.0490		12'-10½		3.082	
								18.908	Total(Pt) Route 13
115	10'-1	5.6	23.44	1	(See Notes)	6'-3	100	17.519 Route 14 Sprinkler, 2E(1'-5), PO(3'-7)
						6'-5	0.244547	-1.264	
26	13'-0		23.44	1.0490		12'-8		3.098	
								19.353	Total(Pt) Route 14
116	12'-1	5.6	23.96	1	(See Notes)	4'-3	100	18.311 Route 15 Sprinkler, 2E(1'-5), PO(3'-7)
						6'-5	0.254746	-0.397	
31	13'-0		23.96	1.0490		10'-8		2.718	
31	13'-0		48.08	2	(See Notes)	25'-11½	100	20.631	Flow (q) from Route 16 PO(8'-9½)
						8'-9½	0.058328		
6	13'-0		72.05	2.1570		34'-8½		2.025	
								22.656	Total(Pt) Route 15
117	12'-1	5.6	23.98	1	(See Notes)	3'-3	100	18.333 Route 16 Sprinkler, 2E(1'-5), PO(3'-7)
						6'-5	0.255036	-0.397	
32	13'-0		23.98	1.0490		9'-8		2.464	
32	13'-0		24.11	2		8'-4½	100	20.399	Flow (q) from Route 19
							0.027605		
31	13'-0		48.08	2.1570		8'-4½		0.232	
								20.631	Total(Pt) Route 16
118	10'-1	5.6	24.03	1	(See Notes)	4'-11½	100	18.418 Route 17 Sprinkler, 2E(1'-5), PO(3'-7)
						6'-5	0.256129	-1.264	
33	13'-0		24.03	1.0490		11'-4½		2.911	
33	13'-0		24.10	2		13'-3½	100	20.065	Flow (q) from Route 18
							0.027655		
34	13'-0		48.13	2.1570		13'-3½		0.368	

Pipe Information

Node 1		Elev 1 (Foot)	K-Factor	Flow added this step (q)	Nominal ID	Fittings & Devices	Length (Foot)	C Factor	Total(Pt)	Notes Fitting/Device (Equivalent Length) Fixed Pressure Losses, when applicable, are added directly to (Pf) and shown as a negative value.
Node 2		Elev 2 (Foot)		Total Flow (Q)	Actual ID		Fitting (Foot)	Pf Friction Loss Per Unit (psi)	Elev(Pe)	
						Total (Foot)		Friction(Pf)		
34	13'-0			24.31	2		9'-1	100	20.433	Flow (q) from Route 20
35	13'-0			72.44	2.1570		9'-1	0.058915	0.534	
35	13'-0			24.61	2	(See Notes)	3'-3½	100	20.967	Flow (q) from Route 22 PO(8'-9½)
29	13'-0			97.05	2.1570		12'-1	0.101203	1.221	
									22.188	Total(Pt) Route 17
119	10'-1	5.6		24.10	1	(See Notes)	4'-2½	100	18.518	***** Route 18 ***** Sprinkler, 2E(1'-5), PO(3'-7)
36	13'-0			24.10	1.0490		6'-5	0.257417	-1.264	
						10'-7½	2.736			
36	13'-0				2		9'-8½	100	19.990	
33	13'-0			24.10	2.1570		9'-8½	0.007691	0.075	
									20.065	Total(Pt) Route 18
120	12'-1	5.6		24.11	1	(See Notes)	4'-3	100	18.531	***** Route 19 ***** Sprinkler, 3E(1'-5)
37	13'-0			24.11	1.0490		4'-3½	0.257580	-0.397	
						8'-6½	2.196			
37	13'-0				2		9'-1	100	20.329	
32	13'-0			24.11	2.1570		9'-1	0.007696	0.070	
									20.399	Total(Pt) Route 19
121	10'-1	5.6		24.31	1	(See Notes)	4'-6	100	18.840	***** Route 20 ***** Sprinkler, 2E(1'-5), PO(3'-7)
34	13'-0			24.31	1.0490		6'-5	0.261552	-1.264	
						10'-11	2.857			
									20.433	Total(Pt) Route 20
122	10'-1	5.6		24.52	1	(See Notes)	4'-1½	100	19.178	***** Route 21 ***** Sprinkler, 2E(1'-5), PO(3'-7)
27	13'-0			24.52	1.0490		6'-5	0.265885	-1.264	
						10'-6½	2.804			
									20.717	Total(Pt) Route 21
123	10'-1	5.6		24.61	1	(See Notes)	4'-6	100	19.308	***** Route 22 ***** Sprinkler, 2E(1'-5), PO(3'-7)
35	13'-0			24.61	1.0490		6'-5	0.267563	-1.264	
						10'-11	2.923			
									20.967	Total(Pt) Route 22

Pipe Information

Node 1	Elev 1 (Foot)	K-Factor	Flow added this step (q)	Nominal ID	Fittings & Devices	Length (Foot)	C Factor	Total(Pt)	Notes Fitting/Device (Equivalent Length) Fixed Pressure Losses, when applicable, are added directly to (Pf) and shown as a negative value.
Total (Foot)	Friction(Pf)								
		124	12'-1	5.6	24.89	1	(See Notes)	7'-5½	
						7'-10	0.273248	-0.397	
10	13'-0		24.89	1.0490		15'-3½		4.180	
								23.535	Total(Pt) Route 23
125	12'-1	5.6	25.05	1	(See Notes)	7'-1½	100	20.016	••••• Route 24 ••••• Sprinkler, 2E(1'-5), PO(3'-7)
						6'-5	0.276626	-0.397	
7	13'-0		25.05	1.0490		13'-6½		3.745	
								23.364	
127	10'-1	5.6	25.09	1	(See Notes)	5'-9	100	20.075	••••• Route 25 ••••• Sprinkler, 3E(1'-5), PO(3'-7)
						7'-10	0.277379	-1.264	
19	13'-0		25.09	1.0490		13'-7		3.770	
								22.581	
126	12'-1	5.6	25.15	1	(See Notes)	5'-0½	100	20.175	••••• Route 26 ••••• Sprinkler, 3E(1'-5), PO(3'-7)
						7'-10	0.278652	-0.397	
8	13'-0		25.15	1.0490		12'-10½		3.591	
								23.369	
128	12'-1	5.6	25.51	1	(See Notes)	4'-8½	100	20.745	••••• Route 27 ••••• Sprinkler, 2E(1'-5), PO(3'-7)
						6'-5	0.285930	-0.397	
9	13'-0		25.51	1.0490		11'-1½		3.182	
								23.530	

Equivalent Pipe Lengths of Valves and Fittings (C=120 only)

C Value Multiplier

$$\left(\frac{\text{Actual Inside Diameter}}{\text{Schedule 40 Steel Pipe Inside Diameter}} \right)^{4.87} = \text{Factor}$$

Value Of C	100	130	140	150
Multiplying Factor	0.713	1.16	1.33	1.51

Fittings Legend

ALV Alarm Valve	AngV Angle Valve	b Bushing
BaIV Ball Valve	BFP Backflow Preventer	BV Butterfly Valve
C Cross Flow Turn 90°	cplg Coupling	Cr Cross Run
CV Check Valve	DelV Deluge Valve	DPV Dry Pipe Valve
E 90° Elbow	EE 45° Elbow	Ee1 11¼° Elbow
Ee2 22½° Elbow	f Flow Device	fd Flex Drop
FDC Fire Department Connectic	fE 90° FireLock(TM) Elbow	fEE 45° FireLock(TM) Elbow
flg Flange	FN Floating Node	fT FireLock(TM) Tee
g Gauge	GloV Globe Valve	GV Gate Valve
Ho Hose	Hose Hose	HV Hose Valve
Hyd Hydrant	LtE Long Turn Elbow	mecT Mechanical Tee
Noz Nozzle	P1 Pump In	P2 Pump Out
PIV Post Indicating Valve	PO Pipe Outlet	PrV Pressure Relief Valve
PRV I Pressure Reducing Valve I	PRV (Pressure Reducing Valve (red Reducer/Adapter
S Supply	sCV Swing Check Valve	SFx Seismic Flex
Spr Sprinkler	St Strainer	T Tee Flow Turn 90°
Tr Tee Run	U Union	WirF Wirsbo
WMV Water Meter Valve	Z Cap	

Job	
Job Number BW25327	Designer TWC
Job Name: ALTIS SERENITY CLUBHOUSE	Phone 919-553-2356
Address 1 325 STREAMSIDE TERRACE	State Certification/License Number 16269FS
Address 2 FUQUAY-VARINA, NC 27526	AHJ
Address 3	Job Site/Building

System	
Density 0.10gpm/ft²	Area of Application 1500ft² (Actual 2414ft²)
Most Demanding Sprinkler Data 5.6 K-Factor 14.82 at 7.000	Hose Streams 100.00
Coverage Per Sprinkler 120ft²	Number Of Sprinklers Calculated 33
	Number Of Nozzles Calculated 0
System Pressure Demand 47.412	System Flow Demand 618.18
Total Demand 718.18 @ 47.412	Pressure Result +33.187 (41.2%)

Supplies						Check Point Gauges			
<u>Node</u>	<u>Name</u>	<u>Flow(gpm)</u>	<u>Hose Flow(gpm)</u>	<u>Static(psi)</u>	<u>Residual(psi)</u>	<u>Identifier</u>	<u>Pressure(psi)</u>	<u>K-Factor(K)</u>	<u>Flow(gpm)</u>
14	Water Supply	969.00	100.00	101.800	64.900	BOR (12)	29.194	114.41	618.18

Altis Fire Sprinkler Uprights **Water Supply at Node 14 (969.00, 0.00, 101.800, 64.900)**

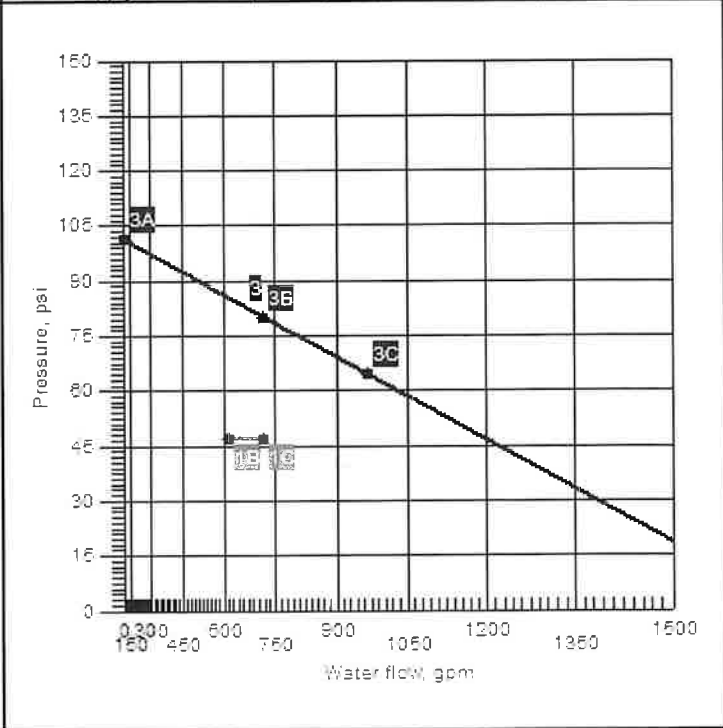
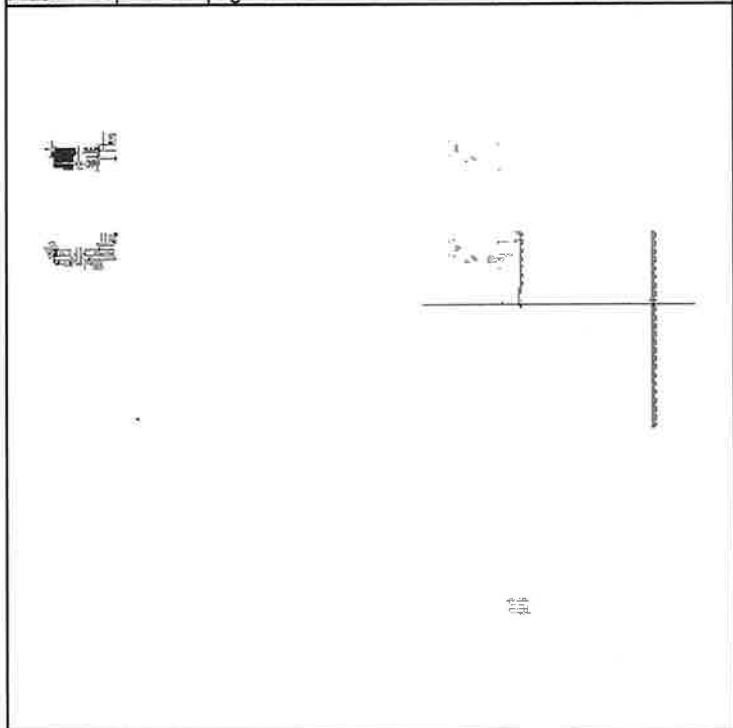

Hydraulic Summary

Job Number: BW25327
Report Description: Light Hazard (2)

Job	
Job Number BW25327	Designer TWC
Job Name ALTIS SERENITY CLUBHOUSE	State Certification/License Number 16269FS
Address 1 325 STREAMSIDE TERRACE	AHJ
Address 2 FUQUAY-VARINA, NC 27526	Job Site/Building
Address 3	Drawing Name Altis Fire Sprinkler Uprights

System		Remote Area(s)	
Most Demanding Sprinkler Data 5.6 K-Factor 14.82 at 7.000		Occupancy Light Hazard	Job Suffix
Hose Allowance At Source 100.00		Density 0.10gpm/ft ²	Area of Application 1500ft ² (Actual 2414ft ²)
Additional Hose Supplies <u>Node</u> <u>Flow(gpm)</u>		Number Of Sprinklers Calculated 33	Number Of Nozzles Calculated 0
		Coverage Per Sprinkler 120ft ²	
Total Hose Streams 100.00			
System Flow Demand 618.18		Total Water Required (Including Hose Allowance) 718.18	
Maximum Pressure Unbalance In Loops 0.000			
Maximum Velocity Above Ground 11.02 between nodes 39 and 38			
Maximum Velocity Under Ground 6.40 between nodes 13 and 12			
Volume capacity of Wet Pipes 7788.08gal		Volume capacity of Dry Pipes 699.91gal	

Supplies											
Node	Name	Hose Flow (gpm)	Static (psi)	Residual (psi)	@	Flow (gpm)	Available (psi)	@	Total Demand (gpm)	Required (psi)	Safety Margin (psi)
14	Water Supply	100.00	101.800	64.900		969.00	80.599		718.18	47.412	33.187

Contractor			
Contractor Number		Contact Name	
Name of Contractor:		Phone	Contact Title
Address 1		Extension	
Address 2		FAX	
Address 3		E-mail	
		Web-Site	

Hydraulic Calculations

for

Project Name: ALTIS SERENITY CLUBHOUSE: (BW25327)
Location: 325 STREAMSIDE TERRACE, FUQUAY-VARINA, NC 27526,
Drawing Name: Altis Fire Sprinkler Uprights

Calculation Date: 2/16/2026

Design

Remote Area Number: 2
Occupancy Classification: Light Hazard

Density: 0.10gpm/ft²
Area of Application: 1500ft² (Actual 2414ft²)
Coverage per Sprinkler: 120ft²
Type of sprinklers calculated: Upright
No. of sprinklers calculated: 33
No. of nozzles calculated: 0

In-rack Demand: N/A gpm at Node: N/A
Hose Streams: 100.00 at Node: 14 Type: Allowance at Source

Total Water Required (including Hose Streams where applicable):
From Water Supply at Node 14: 718.18 @ 47.412 (Safety Margin = 33.187)

Type of System:
Volume of Dry/PreAction/Antifreeze/OtherAgent System: 699.91gal

Name of Contractor:
Address:
Phone Number:
Name of designer: TWC
Authority Having Jurisdiction:

Notes:

Summary Notes:

Water Supply at Node 14



System Demand
Available Water Supply

Job Name: ALTIS SERENITY CLUBHOUSE
Job Number: BW25327
Report Description: Light Hazard (2)
Remote Area Number: 2

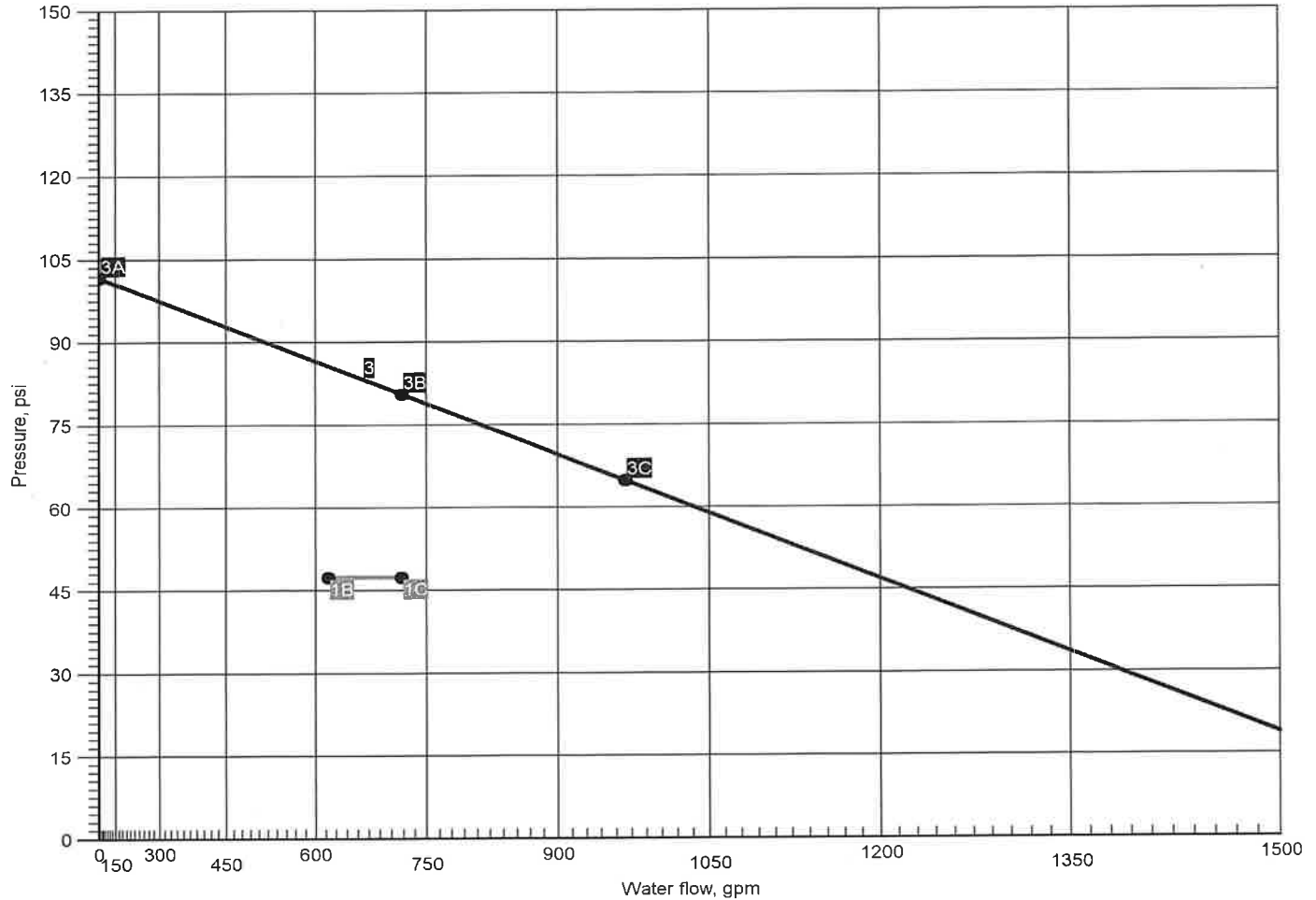

Curve	Data Point	Hydraulic Calculation Results	Additional Data
1	1B	Required Pressure at System Demand: 47.412 @ 618.18	Available Flow @ 20 PSI: 1489.42
	1C	Required Pressure at System Demand (Including Hose Allowance at Source): 47.412 @ 718.18	
3	3A	Available Static Pressure at Water Supply at Node 14: 101.800	
	3B	Available Residual Pressure at System Demand: 80.599 @ 718.18	
	3C	Available Residual Pressure & Flow at Water Supply at Node 14: 64.900 @ 969.00	

Summary Of Outflowing Devices

Device	Actual Flow (gpm)	Minimum Flow (gpm)	K-Factor (K)	Pressure (psi)			
⇒ Sprinkler 201	14.82	12.00	5.6	7.000			
Sprinkler 202	14.84	12.00	5.6	7.025			
Sprinkler 203	14.94	12.00	5.6	7.115			
Sprinkler 204	15.14	12.00	5.6	7.307			
Sprinkler 205	15.43	12.00	5.6	7.596			
Sprinkler 206	15.94	12.00	5.6	8.101			
Sprinkler 207	16.63	12.00	5.6	8.821			
Sprinkler 208	17.46	12.00	5.6	9.726			
Sprinkler 209	18.93	12.00	5.6	11.431			
Sprinkler 210	19.31	12.00	5.6	11.893			
Sprinkler 211	19.89	12.00	5.6	12.611			
Sprinkler 212	17.57	12.00	5.6	9.842			
Sprinkler 213	17.70	12.00	5.6	9.985			
Sprinkler 214	17.27	12.00	5.6	9.505			
Sprinkler 215	17.29	12.00	5.6	9.530			
Sprinkler 216	17.40	12.00	5.6	9.650			
Sprinkler 217	17.62	12.00	5.6	9.905			
Sprinkler 218	17.96	12.00	5.6	10.287			
Sprinkler 219	18.54	12.00	5.6	10.956			
Sprinkler 220	19.33	12.00	5.6	11.911			
Sprinkler 221	17.79	12.00	5.6	10.089			
Sprinkler 222	18.49	12.00	5.6	10.907			
Sprinkler 223	19.98	12.00	5.6	12.724			
Sprinkler 224	20.37	12.00	5.6	13.237			
Sprinkler 225	20.98	12.00	5.6	14.033			
Sprinkler 226	18.60	12.00	5.6	11.036			
Sprinkler 227	18.74	12.00	5.6	11.195			
Sprinkler 228	23.06	12.00	5.6	16.963			
Sprinkler 229	23.10	12.00	5.6	17.020			
Sprinkler 230	23.20	12.00	5.6	17.159			
Sprinkler 231	23.24	12.00	5.6	17.216			
Sprinkler 232	23.26	12.00	5.6	17.255			
Sprinkler 233	23.37	12.00	5.6	17.421			

⇒ Most Demanding Sprinkler Data

Supply Analysis							
Node	Name	Static (psi)	Residual (psi) @	Flow (gpm)	Available (psi) @	Total Demand (gpm)	Required Pressure (psi)
14	Water Supply	101.800	64.900	969.00	80.599	718.18	47.412
Node Analysis							
Node Number	Elevation (Foot)	Node Type	Pressure at Node (psi)	Discharge at Node (gpm)	Notes		
14	-3'-0	Supply	47.412	618.18			
201	23'-0	Sprinkler	7.000	14.82			
202	23'-0	Sprinkler	7.025	14.84			
203	23'-0	Sprinkler	7.115	14.94			
204	23'-0	Sprinkler	7.307	15.14			
205	23'-0	Sprinkler	7.596	15.43			
206	23'-0	Sprinkler	8.101	15.94			
207	23'-0	Sprinkler	8.821	16.63			
208	19'-9½	Sprinkler	9.726	17.46			
209	18'-4	Sprinkler	11.431	18.93			
210	18'-4	Sprinkler	11.893	19.31			
211	18'-4	Sprinkler	12.611	19.89			
212	19'-9½	Sprinkler	9.842	17.57			
213	19'-9½	Sprinkler	9.985	17.70			
214	18'-3½	Sprinkler	9.505	17.27			
215	18'-3½	Sprinkler	9.530	17.29			
216	18'-3½	Sprinkler	9.650	17.40			
217	18'-3½	Sprinkler	9.905	17.62			

Node Number	Elevation (Foot)	Node Type	Pressure at Node (psi)	Discharge at Node (gpm)	Notes
218	18'-3½	Sprinkler	10.287	17.96	
219	18'-3½	Sprinkler	10.956	18.54	
220	18'-3½	Sprinkler	11.911	19.33	
221	23'-0	Sprinkler	10.089	17.79	
222	16'-11	Sprinkler	10.907	18.49	
223	15'-5½	Sprinkler	12.724	19.98	
224	15'-5½	Sprinkler	13.237	20.37	
225	15'-5½	Sprinkler	14.033	20.98	
226	16'-11	Sprinkler	11.036	18.60	
227	16'-11	Sprinkler	11.195	18.74	
228	13'-0	Sprinkler	16.963	23.06	
229	13'-0	Sprinkler	17.020	23.10	
230	13'-0	Sprinkler	17.159	23.20	
231	13'-0	Sprinkler	17.216	23.24	
232	13'-0	Sprinkler	17.255	23.26	
233	13'-0	Sprinkler	17.421	23.37	
11	3'-10		27.977	0.00	
12	1'-1	Gauge	29.194	0.00	BOR
13	-3'-0		47.269	0.00	
38	23'-0		10.145	0.00	
39	13'-0		17.544	0.00	
40	13'-0		17.566	0.00	

Node Number	Elevation (Foot)	Node Type	Pressure at Node (psi)	Discharge at Node (gpm)	Notes
41	13'-0		17.632	0.00	
42	13'-0		17.904	0.00	
43	13'-0		18.304	0.00	
44	18'-4		11.078	0.00	
45	18'-4		11.201	0.00	
46	18'-4		11.043	0.00	
48	13'-0		17.537	0.00	
49	15'-5½		12.332	0.00	
50	15'-5½		12.469	0.00	
51	15'-5½		12.293	0.00	
52	13'-0		17.347	0.00	
53	13'-0		17.521	0.00	

Pipe Information									
Node 1	Elev 1 (Foot)	K-Factor	Flow added this step (q)	Nominal ID	Fittings & Devices	Length (Foot)	C Factor	Total(Pt)	Notes
Node 2	Elev 2 (Foot)		Total Flow (Q)	Actual ID	Equiv. Length (Foot)	Fitting (Foot)	Pf Friction Loss Per Unit (psi)	Elev(Pe)	Fitting/Device (Equivalent Length) Fixed Pressure Losses, when applicable, are added directly to (Pf) and shown as a negative value
						Total (Foot)		Friction(Pf)	
201	23'-0	5.6	14.82	2	(See Notes)	8'-0	100	7.000 Route 1 Sprinkler
202	23'-0		14.82	2.1570		8'-0	0.003127	0.025	
202	23'-0	5.6	14.84	2	(See Notes)	8'-0	100	7.025	Sprinkler
203	23'-0		29.66	2.1570		8'-0	0.011292	0.090	
203	23'-0	5.6	14.94	2	(See Notes)	8'-0	100	7.115	Sprinkler
204	23'-0		44.60	2.1570		8'-0	0.024016	0.192	
204	23'-0	5.6	15.14	2	(See Notes)	7'-0	100	7.307	Sprinkler
205	23'-0		59.73	2.1570		7'-0	0.041239	0.289	
205	23'-0	5.6	15.43	2	(See Notes)	8'-0	100	7.596	Sprinkler
206	23'-0		75.17	2.1570		8'-0	0.063090	0.505	
206	23'-0	5.6	15.94	2	(See Notes)	8'-0	100	8.101	Sprinkler
207	23'-0		91.11	2.1570		8'-0	0.090046	0.720	
207	23'-0	5.6	16.63	2	(See Notes)	2'-0	100	8.821	Sprinkler, T(8'-9½)
38	23'-0		107.74	2.1570		8'-9½	0.122797	1.324	
						10'-9½			
38	23'-0		17.79	2	(See Notes)	10'-0	100	10.145	Flow (q) from Route 6 PO(8'-9½)
39	13'-0		125.53	2.1570		8'-9½	0.162912	4.339	
						18'-9½		3.060	
39	13'-0		125.40	6		7'-6	100	17.544	Flow (q) from Route 2
40	13'-0		250.92	6.3570		7'-6	0.003037	0.023	
40	13'-0		110.86	6		11'-0	100	17.566	Flow (q) from Route 3
41	13'-0		361.78	6.3570		11'-0	0.005976	0.066	
41	13'-0		117.16	6	(See Notes)	14'-6½	100	17.632	Flow (q) from Route 7 E(12'-6½)
42	13'-0		478.95	6.3570		12'-6½	0.010042	0.272	
						27'-1			

Pipe Information									
Node 1	Elev 1 (Foot)	K-Factor	Flow added this step (q)	Nominal ID	Fittings & Devices	Length (Foot)	C Factor	Total(Pt)	Notes
Node 2	Elev 2 (Foot)		Total Flow (Q)	Actual ID	Equiv. Length (Foot)	Fitting (Foot)	Pf Friction Loss Per Unit (psi)	Elev(Pe)	Fitting/Device (Equivalent Length) Fixed Pressure Losses, when applicable, are added directly to (Pf) and shown as a negative value.
						Total (Foot)		Friction(Pf)	
42	13'-0		69.43	6		31'-0	100	17.904	Flow (q) from Route 10
43	13'-0		548.38	6.3570		31'-0	0.012900	0.400	
43	13'-0		69.81	6	(See Notes)	206'-6	100	18.304	Flow (q) from Route 11 11E(12'-6½), DPV, BV(8'-11½)
						147'-0½	0.016101	3.981	
11	3'-10		618.18	6.3570	353'-6	5.692			
11	3'-10			6	(See Notes)	2'-9	120	27.977	BOR
							0.011492	1.185	
12	1'-1		618.18	6.3570	2'-9	0.031			
12	1'-1			6	(See Notes)	202'-10½	140	29.194	5E(22'-1), BFP(-13.000), T(47'-3½)
						157'-7	0.009169	1.770	
13	-3'-0		618.18	6.2800	360'-5½	16.305			
13	-3'-0			12	Supply (See Notes)	340'-0	140	47.269	Avl. Pressure @ Supply: 80.599 S, C(98'-3½)
						98'-3½	0.000326		
14	-3'-0		618.18	12.4600	438'-3½	0.143			
			100.00					47.412	Hose Allowance At Source
14			718.18						Total(Pt) Route 1
214	18'-3½	5.6	17.27	2	(See Notes)	6'-0	100	9.505	••••• Route 2 ••••• Sprinkler
215	18'-3½		17.27	2.1570		6'-0	0.004150	0.025	
215	18'-3½	5.6	17.29	2	(See Notes)	8'-0	100	9.530	Sprinkler
216	18'-3½		34.55	2.1570		8'-0	0.014979	0.120	
216	18'-3½	5.6	17.40	2	(See Notes)	8'-0	100	9.650	Sprinkler
217	18'-3½		51.95	2.1570		8'-0	0.031849	0.255	
217	18'-3½	5.6	17.62	2	(See Notes)	7'-0	100	9.905	Sprinkler
							0.054676	-0.000	
218	18'-3½		69.57	2.1570	7'-0	0.383			
218	18'-3½	5.6	17.96	2	(See Notes)	8'-0	100	10.287	Sprinkler
219	18'-3½		87.53	2.1570		8'-0	0.083621	0.669	

Pipe Information									
Node 1	Elev 1 (Foot)	K-Factor	Flow added this step (q)	Nominal ID	Fittings & Devices	Length (Foot)	C Factor	Total(Pt)	Notes
Node 2	Elev 2 (Foot)		Total Flow (Q)	Actual ID	Equiv. Length (Foot)	Fitting (Foot)	Pf Friction Loss Per Unit (psi)	Elev(Pe)	Fitting/Device (Equivalent Length) Fixed Pressure Losses, when applicable, are added directly to (Pf) and shown as a negative value.
						Total (Foot)		Friction(Pf)	
219	18'-3½	5.6	18.54	2	(See Notes)	8'-0	100	10.956	Sprinkler
220	18'-3½		106.07	2.1570		8'-0	0.119299	0.954	
220	18'-3½	5.6	19.33	2	(See Notes)	7'-3½	100	11.911	Sprinkler, E(4'-4½), PO(8'-9½)
						13'-2	0.162600	2.298	
48	13'-0		125.40	2.1570		20'-5½		3.328	
48	13'-0			6		7'-11	100	17.537	
39	13'-0		125.40	6.3570		7'-11	0.000842	0.007	
								17.544	Total(Pt) Route 2
208	19'-9½	5.6	17.46	1	(See Notes)	1'-5½	100	9.726 Route 3 Sprinkler, PO(3'-7)
44	18'-4		17.46	1.0490		3'-7	0.141893	0.637	
						5'-0½		0.714	
44	18'-4		17.70	2		8'-0	100	11.078	Flow (q) from Route 5
45	18'-4		35.16	2.1570		8'-0	0.015470	0.124	
45	18'-4		17.57	2		7'-0	100	11.201	Flow (q) from Route 4
209	18'-4		52.73	2.1570		7'-0	0.032740	0.229	
209	18'-4	5.6	18.93	2	(See Notes)	8'-0	100	11.431	Sprinkler
210	18'-4		71.66	2.1570		8'-0	0.057752	0.462	
210	18'-4	5.6	19.31	2	(See Notes)	8'-0	100	11.893	Sprinkler
211	18'-4		90.97	2.1570		8'-0	0.089801	0.718	
211	18'-4	5.6	19.89	2	(See Notes)	7'-4	100	12.611	Sprinkler, E(4'-4½), PO(8'-9½)
						13'-2	0.129457	2.304	
40	13'-0		110.86	2.1570		20'-6		2.651	
								17.566	Total(Pt) Route 3
212	19'-9½	5.6	17.57	1	(See Notes)	1'-5½	100	9.842 Route 4 Sprinkler, PO(3'-7)
						3'-7	0.143456	0.637	
45	18'-4		17.57	1.0490		5'-0½		0.722	
								11.201	Total(Pt) Route 4

Pipe Information

Node 1		Elev 1 (Foot)	K-Factor	Flow added this step (q)	Nominal ID	Fittings & Devices	Length (Foot)	C Factor	Total(Pt)	Notes Fitting/Device (Equivalent Length) Fixed Pressure Losses, when applicable, are added directly to (Pf) and shown as a negative value.
Node 2		Elev 2 (Foot)		Total Flow (Q)	Actual ID	Equiv. Length (Foot)	Fitting (Foot)	Pf Friction Loss Per Unit (psi)	Elev(Pe)	
						Total (Foot)			Friction(Pf)	
213	19'-9½	5.6	17.70	1	(See Notes)	1'-5½	100	9.985	••••• Route 5 ••••• Sprinkler, E(1'-5)	
46	18'-4		17.70	1.0490		1'-5	0.145380	0.637		
						2'-10½		0.421		
46	18'-4			2		8'-0	100	11.043		
44	18'-4		17.70	2.1570		8'-0	0.004343	0.035		
									11.078	Total(Pt) Route 5
221	23'-0	5.6	17.79	2	(See Notes)	4'-0	100	10.089	••••• Route 6 ••••• Sprinkler, T(8'-9½)	
38	23'-0		17.79	2.1570		8'-9½	0.004385	0.056		
						12'-9				
									10.145	Total(Pt) Route 6
222	16'-11	5.6	18.49	1	(See Notes)	1'-5½	100	10.907	••••• Route 7 ••••• Sprinkler, PO(3'-7)	
49	15'-5½		18.49	1.0490		3'-7	0.157755	0.632		
						5'-0½		0.792		
49	15'-5½		18.74	2		8'-0	100	12.332	Flow (q) from Route 9	
50	15'-5½		37.23	2.1570		8'-0	0.017197	0.138		
50	15'-5½		18.60	2		7'-0	100	12.469	Flow (q) from Route 8	
223	15'-5½		55.83	2.1570		7'-0	0.036396	0.255		
223	15'-5½	5.6	19.98	2	(See Notes)	8'-0	100	12.724	Sprinkler	
224	15'-5½		75.81	2.1570		8'-0	0.064089	0.513		
224	15'-5½	5.6	20.37	2	(See Notes)	8'-0	100	13.237	Sprinkler	
225	15'-5½		96.18	2.1570		8'-0	0.099547	0.796		
225	15'-5½	5.6	20.98	2	(See Notes)	4'-5½	100	14.033	Sprinkler, E(4'-4½), PO(8'-9½)	
41	13'-0		117.16	2.1570		13'-2	0.143398	1.070		
						17'-7½		2.529		
									17.632	Total(Pt) Route 7
226	16'-11	5.6	18.60	1	(See Notes)	1'-5½	100	11.036	••••• Route 8 ••••• Sprinkler, PO(3'-7)	
50	15'-5½		18.60	1.0490		3'-7	0.159479	0.632		
						5'-0½		0.801		

Pipe Information

Node 1	Elev 1 (Foot)	K-Factor	Flow added this step (q)	Nominal ID	Fittings & Devices	Length (Foot)	C Factor	Total(Pt)	Notes
								12.469	Total(Pt) Route 8
227	16'-11	5.6	18.74	1	(See Notes)	1'-5½	100	11.195 Route 9 Sprinkler, E(1'-5)
51	15'-5½		18.74	1.0490		1'-5	0.161601	0.632	
						2'-10½		0.466	
51	15'-5½			2		8'-0	100	12.293	
49	15'-5½		18.74	2.1570		8'-0	0.004828	0.039	
								12.332	
228	13'-0	5.6	23.06	2	(See Notes)	8'-0	100	16.963 Route 10 Sprinkler
229	13'-0		23.06	2.1570		8'-0	0.007091	0.057	
229	13'-0	5.6	23.10	2	(See Notes)	4'-0	100	17.020	Sprinkler, T(8'-9½)
52	13'-0		46.17	2.1570		8'-9½	0.025604	0.327	
						12'-9½			
52	13'-0		23.26	2	(See Notes)	1'-5½	100	17.347	Flow (q) from Route 12 PO(8'-9½)
42	13'-0		69.43	2.1570		8'-9½	0.054467	0.557	
						10'-3			
								17.904	Total(Pt) Route 10
230	13'-0	5.6	23.20	2	(See Notes)	8'-0	100	17.159 Route 11 Sprinkler
231	13'-0		23.20	2.1570		8'-0	0.007167	0.057	
231	13'-0	5.6	23.24	2	(See Notes)	3'-0	100	17.216	Sprinkler, T(8'-9½)
53	13'-0		46.43	2.1570		8'-9½	0.025877	0.305	
						11'-9½			
53	13'-0		23.37	2	(See Notes)	5'-5½	100	17.521	Flow (q) from Route 13 PO(8'-9½)
43	13'-0		69.81	2.1570		8'-9½	0.055017	0.783	
						14'-3			
								18.304	Total(Pt) Route 11
232	13'-0	5.6	23.26	2	(See Notes)	4'-0	100	17.255 Route 12 Sprinkler, T(8'-9½)
52	13'-0		23.26	2.1570		8'-9½	0.007204	0.092	
						12'-9½			
								17.347	Total(Pt) Route 12

Pipe Information

Pipe Information										
Node 1	Elev 1 (Foot)	K-Factor	Flow added this step (q)	Nominal ID	Fittings & Devices	Length (Foot)	C Factor	Total(Pt)	Notes	
									Fitting/Device (Equivalent Length) Fixed Pressure Losses, when applicable, are added directly to (Pf) and shown as a negative value.	
Node 2	Elev 2 (Foot)		Total Flow (Q)	Actual ID	Equiv. Length (Foot)	Fitting (Foot)	Pf Friction Loss Per Unit (psi)	Elev(Pe)	Friction(Pf)	
233	13'-0	5.6	23.37	2	(See Notes)	5'-0	100	17.421		***** Route 13 ***** Sprinkler, T(8'-9½)
53	13'-0		23.37	2.1570		8'-9½	0.007268			
						13'-9½			0.100	
								17.521	Total(Pt) Route 13	

Equivalent Pipe Lengths of Valves and Fittings (C=120 only)

C Value Multiplier

$$\left(\frac{\text{Actual Inside Diameter}}{\text{Schedule 40 Steel Pipe Inside Diameter}} \right)^{4.87} = \text{Factor}$$

Value Of C	100	130	140	150
Multiplying Factor	0.713	1.16	1.33	1.51

Fittings Legend

ALV Alarm Valve	AngV Angle Valve	b Bushing
BalV Ball Valve	BFP Backflow Preventer	BV Butterfly Valve
C Cross Flow Turn 90°	cplg Coupling	Cr Cross Run
CV Check Valve	DelV Deluge Valve	DPV Dry Pipe Valve
E 90° Elbow	EE 45° Elbow	Ee1 11¼° Elbow
Ee2 22½° Elbow	f Flow Device	fd Flex Drop
FDC Fire Department Connectic	fE 90° FireLock(TM) Elbow	fEE 45° FireLock(TM) Elbow
flg Flange	FN Floating Node	fT FireLock(TM) Tee
g Gauge	GloV Globe Valve	GV Gate Valve
Ho Hose	Hose Hose	HV Hose Valve
Hyd Hydrant	LtE Long Turn Elbow	mecT Mechanical Tee
Noz Nozzle	P1 Pump In	P2 Pump Out
PIV Post Indicating Valve	PO Pipe Outlet	PrV Pressure Relief Valve
PRV Pressure Reducing Valve	PRV (Pressure Reducing Valve (red Reducer/Adapter
S Supply	sCV Swing Check Valve	SFx Seismic Flex
Spr Sprinkler	St Strainer	T Tee Flow Turn 90°
Tr Tee Run	U Union	WirF Wirsbo
WMV Water Meter Valve	Z Cap	

Hydraulic Overview

Job	
Job Number BW25327	Designer TWC
Job Name: ALTIS SERENITY CLUBHOUSE	Phone 919-553-2356
Address 1 325 STREAMSIDE TERRACE	State Certification/License Number 16269FS
Address 2 FUQUAY-VARINA, NC 27526	AHJ
Address 3	Job Site/Building

System	
Density 0.10gpm/ft²	Area of Application 1500ft² (Actual 168ft²)
Most Demanding Sprinkler Data 8 K-Factor 38.00 at 22.563	Hose Streams 100.00
Coverage Per Sprinkler 360ft²	Number Of Sprinklers Calculated 7
System Pressure Demand 61.491	System Flow Demand 271.44
Total Demand 371.44 @ 61.491	Pressure Result +34.048 (35.6%)

Supplies						Check Point Gauges			
Node	Name	Flow(gpm)	Hose Flow(gpm)	Static(psi)	Residual(psi)	Identifier	Pressure(psi)	K-Factor(K)	Flow(gpm)
14	Water Supply	969.00	100.00	101.800	64.900	BOR (12)	45.969	40.04	271.44

Altis Fire Sprinkler Uprights | **Water Supply at Node 14 (969.00, 0.00, 101.800, 64.900)**

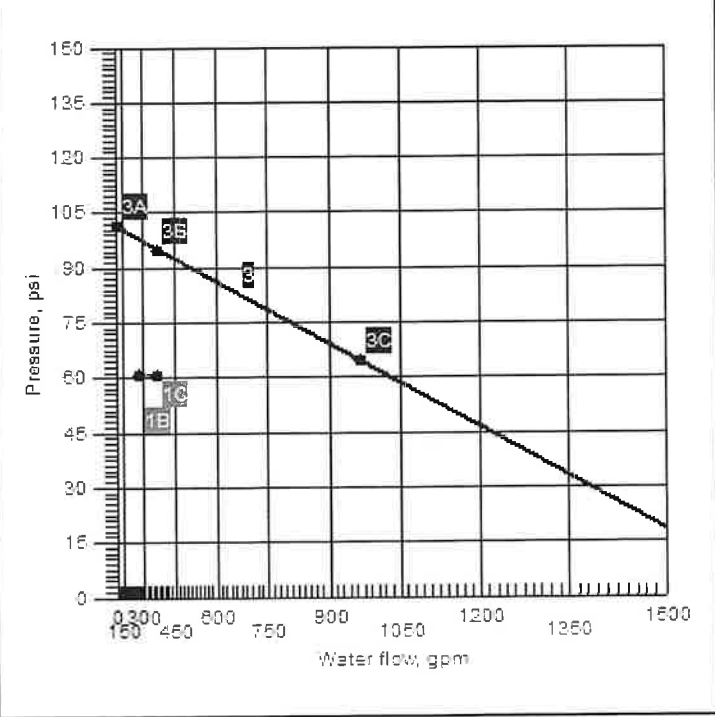
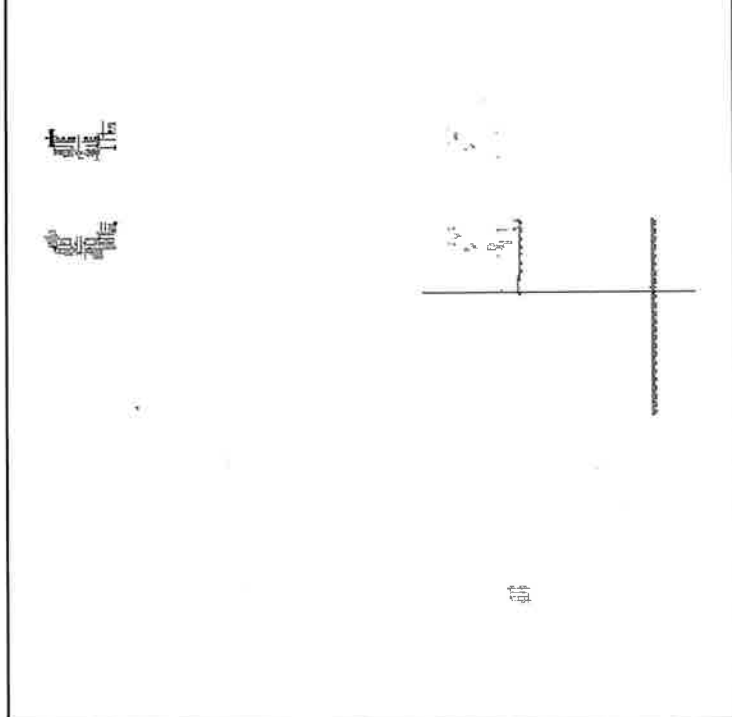

Hydraulic Summary

Job Number: BW25327
Report Description: Light Hazard (3)

Job	
Job Number BW25327	Designer TWC
Job Name: ALTIS SERENITY CLUBHOUSE	State Certification/License Number 16269FS
Address 1 325 STREAMSIDE TERRACE	AHJ
Address 2 FUQUAY-VARINA, NC 27526	Job Site/Building
Address 3	Drawing Name Altis Fire Sprinkler Uprights

System	Remote Area(s)	
Most Demanding Sprinkler Data 8 K-Factor 38.00 at 22.563	Occupancy Light Hazard	Job Suffix
Hose Allowance At Source 100.00	Density 0.10gpm/ft²	Area of Application 1500ft² (Actual 168ft²)
Additional Hose Supplies Node Flow(gpm)	Number Of Sprinklers Calculated 7	Number Of Nozzles Calculated 0
	Coverage Per Sprinkler 360ft²	
Total Hose Streams 100.00		
System Flow Demand 271.44	Total Water Required (Including Hose Allowance) 371.44	
Maximum Pressure Unbalance In Loops 0.000		
Maximum Velocity Above Ground 15.97 between nodes 55 and 54		
Maximum Velocity Under Ground 2.81 between nodes 13 and 12		
Volume capacity of Wet Pipes 7788.08gal	Volume capacity of Dry Pipes 699.91gal	

Supplies									
Node	Name	Hose Flow (gpm)	Static (psi)	Residual (psi) @	Flow (gpm)	Available (psi) @	Total Demand (gpm)	Required (psi)	Safety Margin (psi)
14	Water Supply	100.00	101.800	64.900	969.00	95.539	371.44	61.491	34.048

Contractor			
Contractor Number		Contact Name	
Name of Contractor:		Phone	Contact Title
Address 1		FAX	
Address 2		E-mail	
Address 3		Web-Site	

Hydraulic Calculations

for

Project Name: ALTIS SERENITY CLUBHOUSE: (BW25327)
Location: 325 STREAMSIDE TERRACE, FUQUAY-VARINA, NC 27526,
Drawing Name: Altis Fire Sprinkler Uprights

Calculation Date: 2/16/2026

Design

Remote Area Number: 3

Occupancy Classification: Light Hazard

Density 0.10gpm/ft²

Area of Application: 1500ft² (Actual 168ft²)

Coverage per Sprinkler: 360ft²

Type of sprinklers calculated: Upright

No. of sprinklers calculated: 7

No. of nozzles calculated: 0

In-rack Demand: N/A gpm at Node: N/A

Hose Streams: 100.00 at Node: 14 Type: Allowance at Source

Total Water Required (including Hose Streams where applicable):

From Water Supply at Node 14: 371.44 @ 61.491 (Safety Margin = 34.048)

Type of System:

Volume of Dry/PreAction/Antifreeze/OtherAgent System: 699.91gal

Name of Contractor:

Address:

Phone Number:

Name of designer: TWC

Authority Having Jurisdiction:

Notes:

Summary Notes:

Water Supply at Node 14

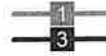

System Demand
Available Water Supply

Job Name: ALTIS SERENITY CLUBHOUSE
Job Number: BW25327
Report Description: Light Hazard (3)
Remote Area Number: 3

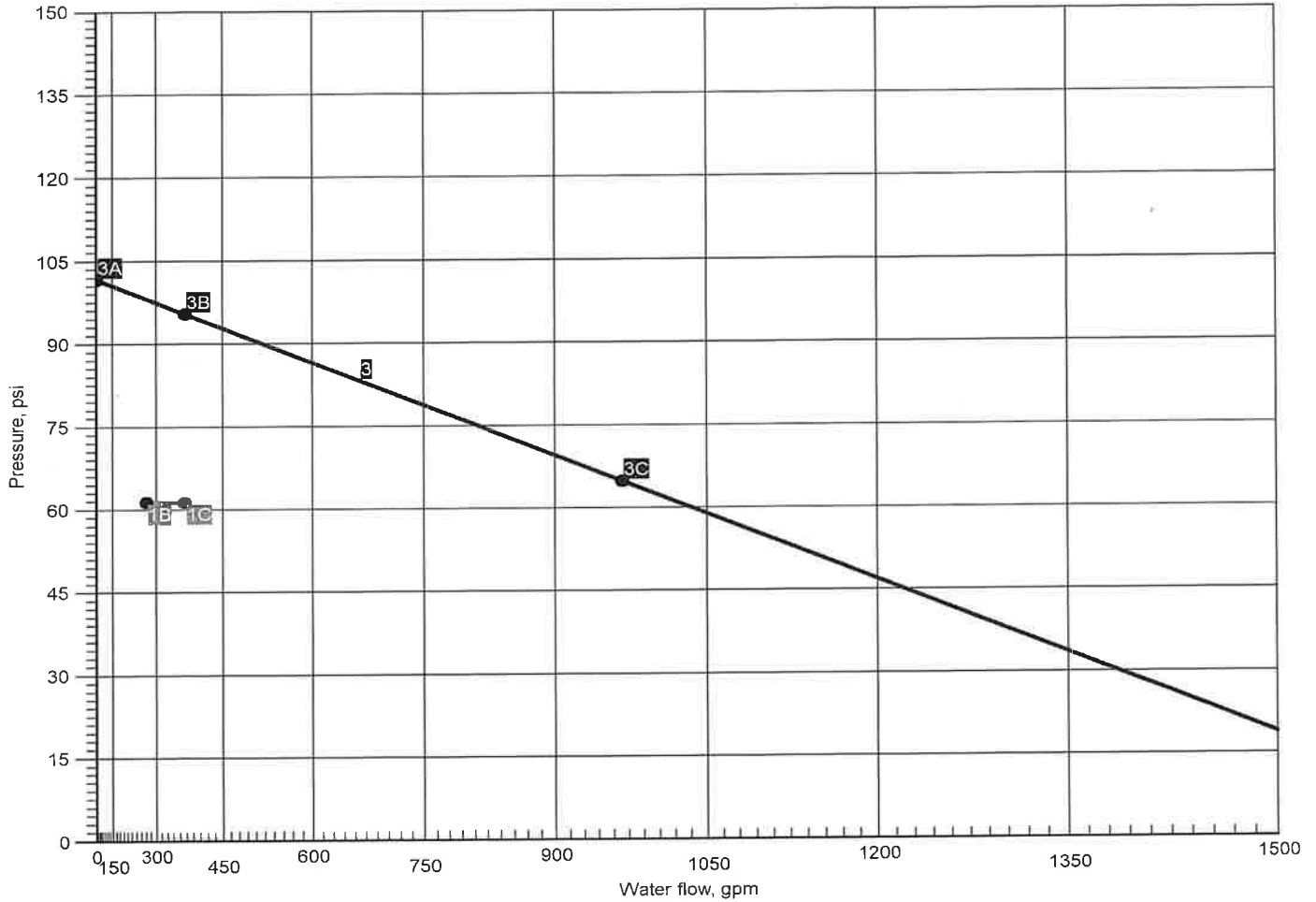

Curve	Data Point	Hydraulic Calculation Results	Additional Data
1	1B	Required Pressure at System Demand: 61.491 @ 271.44	Available Flow @ 20 PSI: 1489.42
	1C	Required Pressure at System Demand (Including Hose Allowance at Source): 61.491 @ 371.44	
3	3A	Available Static Pressure at Water Supply at Node 14: 101.800	
	3B	Available Residual Pressure at System Demand: 95.539 @ 371.44	
	3C	Available Residual Pressure & Flow at Water Supply at Node 14: 64.900 @ 969.00	

Summary Of Outflowing Devices

Device	Actual Flow (gpm)	Minimum Flow (gpm)	K-Factor (K)	Pressure (psi)			
⇒ Sprinkler 301	38.00	38.00	8	22.563			
Sprinkler 302	38.09	38.00	8	22.670			
Sprinkler 303	38.41	38.00	8	23.057			
Sprinkler 304	39.09	38.00	8	23.881			
Sprinkler 305	39.11	38.00	8	23.899			
Sprinkler 306	39.20	38.00	8	24.012			
Sprinkler 307	39.53	38.00	8	24.421			

⇒ Most Demanding Sprinkler Data

Supply Analysis

Node	Name	Static (psi)	Residual (psi) @	Flow (gpm)	Available (psi) @	Total Demand (gpm)	Required Pressure (psi)
14	Water Supply	101.800	64.900	969.00	95.539	371.44	61.491

Node Analysis

Node Number	Elevation (Foot)	Node Type	Pressure at Node (psi)	Discharge at Node (gpm)	Notes
14	-3'-0	Supply	61.491	271.44	
301	16'-11	Sprinkler	22.563	38.00	
302	16'-11	Sprinkler	22.670	38.09	
303	16'-11	Sprinkler	23.057	38.41	
304	16'-11	Sprinkler	23.881	39.09	
305	16'-11	Sprinkler	23.899	39.11	
306	16'-11	Sprinkler	24.012	39.20	
307	16'-11	Sprinkler	24.421	39.53	
5	13'-0		39.323	0.00	
11	3'-10		44.777	0.00	
12	1'-1	Gauge	45.969	0.00	BOR
13	-3'-0		61.460	0.00	
54	16'-11		26.333	0.00	
55	13'-0		38.685	0.00	

Pipe Information

Node 1	Elev 1 (Foot)	K-Factor	Flow added this step (q)	Nominal ID	Fittings & Devices	Length (Foot)	C Factor	Total(Pt)	Notes
301	16'-11	8	38.00	2	(See Notes)	6'-0	100	22.563	••••• Route 1 ••••• Sprinkler
302	16'-11		38.00	2.1570		6'-0	0.017860	0.107	
302	16'-11	8	38.09	2	(See Notes)	6'-0	100	22.670	Sprinkler
303	16'-11		76.09	2.1570		6'-0	0.064528	0.387	
303	16'-11	8	38.41	2	(See Notes)	6'-0	100	23.057	Sprinkler
304	16'-11		114.50	2.1570		6'-0	0.137438	0.825	
304	16'-11	8	39.09	2	(See Notes)	1'-7	100	23.881	Sprinkler, T(8'-9½)
						8'-9½	0.236650		
54	16'-11		153.60	2.1570		10'-4½		2.451	
54	16'-11		117.84	2½	(See Notes)	24'-0	100	26.333	Flow (q) from Route 2 E(5'-10½), PO(11'-9)
						17'-7½	0.256003	1.698	
55	13'-0		271.44	2.6350		41'-7½		10.655	
55	13'-0			4	(See Notes)	7'-1	100	38.685	T(18'-9½)
						18'-9½	0.024673		
5	13'-0		271.44	4.2600		25'-10½		0.638	
5	13'-0			6	(See Notes)	259'-8½	100	39.323	12E(12'-6½), DPV, BV(8'-11½)
						159'-7	0.003512	3.981	
11	3'-10		271.44	6.3570		419'-3½		1.473	
11	3'-10			6	(See Notes)	2'-9	120	44.777	BOR
							0.002507	1.185	
12	1'-1		271.44	6.3570		2'-9		0.007	
12	1'-1			6	(See Notes)	202'-10½	140	45.969	5E(22'-1), BFP(-13.000), T(47'-3½)
						157'-7	0.002000	1.770	
13	-3'-0		271.44	6.2800		360'-5½		13.721	
13	-3'-0			12	Supply (See Notes)	340'-0	140	61.460	Avl. Pressure @ Supply: 95.539 S, C(98'-3½)
						98'-3½	0.000071		
14	-3'-0		271.44	12.4600		438'-3½		0.031	
			100.00				61.491	Hose Allowance At Source	
14			371.44					Total(Pt) Route 1	

Pipe Information

Node 1	Elev 1 (Foot)	K-Factor	Flow added this step (q)	Nominal ID	Fittings & Devices	Length (Foot)	C Factor	Total(Pt)	Notes
305	16'-11	8	39.11	2	(See Notes)	6'-0	100	23.899	***** Route 2 ***** Sprinkler
306	16'-11		39.11	2.1570		6'-0	0.018837	0.113	
306	16'-11	8	39.20	2	(See Notes)	6'-0	100	24.012	Sprinkler
307	16'-11		78.31	2.1570		6'-0	0.068055	0.408	
307	16'-11	8	39.53	2	(See Notes)	4'-5	100	24.421	Sprinkler, T(8'-9½)
54	16'-11		117.84	2.1570		8'-9½	0.144949	1.912	
						13'-2½			
								26.333	Total(Pt) Route 2

Equivalent Pipe Lengths of Valves and Fittings (C=120 only)

C Value Multiplier

$$\left(\frac{\text{Actual Inside Diameter}}{\text{Schedule 40 Steel Pipe Inside Diameter}} \right)^{4.87} = \text{Factor}$$

Value Of C	100	130	140	150
Multiplying Factor	0.713	1.16	1.33	1.51

Fittings Legend

ALV Alarm Valve	AngV Angle Valve	b Bushing
BalV Ball Valve	BFP Backflow Preventer	BV Butterfly Valve
C Cross Flow Turn 90°	cplg Coupling	Cr Cross Run
CV Check Valve	DelV Deluge Valve	DPV Dry Pipe Valve
E 90° Elbow	EE 45° Elbow	Ee1 11¼° Elbow
Ee2 22½° Elbow	f Flow Device	fd Flex Drop
FDC Fire Department Connectic	fE 90° FireLock(TM) Elbow	fEE 45° FireLock(TM) Elbow
flg Flange	FN Floating Node	fT FireLock(TM) Tee
g Gauge	GloV Globe Valve	GV Gate Valve
Ho Hose	Hose Hose	HV Hose Valve
Hyd Hydrant	LtE Long Turn Elbow	mecT Mechanical Tee
Noz Nozzle	P1 Pump In	P2 Pump Out
PIV Post Indicating Valve	PO Pipe Outlet	PrV Pressure Relief Valve
PRV Pressure Reducing Valve	PRV (Pressure Reducing Valve (red Reducer/Adapter
S Supply	sCV Swing Check Valve	SFx Seismic Flex
Spr Sprinkler	St Strainer	T Tee Flow Turn 90°
Tr Tee Run	U Union	WirF Wirsbo
WMV Water Meter Valve	Z Cap	

SPRINKLER HEADS

FireLock™ Series FL-QR/DRY

Standard Coverage, Quick Response Dry, Upright, Pendent and Recessed Pendent Sprinklers K5.6 (8.1), K8.0 (11.5)



45.01

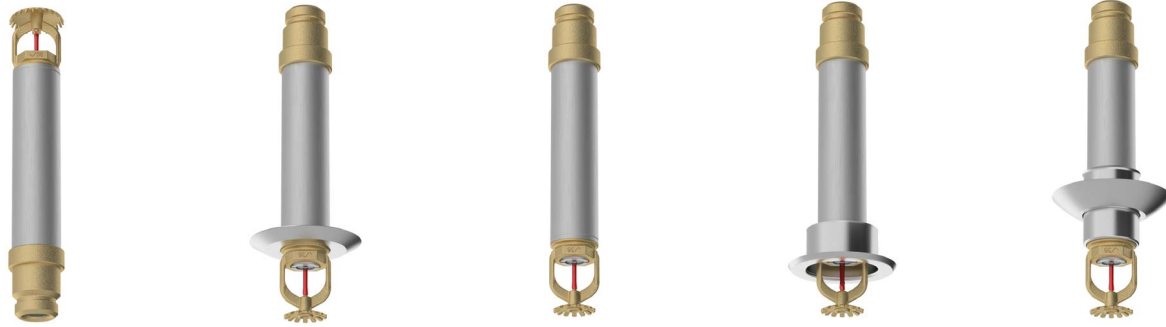

1.0 PRODUCT DESCRIPTION

UPRIGHT QUICK RESPONSE DRY SPRINKLERS		
SIN	V3602	V3604
ORIENTATION	UPRIGHT	UPRIGHT
K-FACTOR ¹	5.6 Imp./8.1 S.I.	8.0 Imp./11.5 S.I.
CONNECTION	1" NPT/25mm BSPT/1" IGS	1" NPT/25mm BSPT/1" IGS
MAX WORKING PRESSURE	175 psi (1200 kPa)	175 psi (1200 kPa)
ESCUTCHEON	Plain	Plain
GLOBE EQUIVALENT	GL5639	GL8139

PENDENT QUICK RESPONSE DRY SPRINKLERS		
SIN	V3614	V3616
ORIENTATION	PENDENT	PENDENT
K-FACTOR ¹	5.6 Imp./8.1 S.I.	8.0 Imp./11.5 S.I.
CONNECTION	1" NPT/25mm BSPT/1" IGS	1" NPT/25mm BSPT/1" IGS
MAX WORKING PRESSURE	175 psi (1200 kPa)	175 psi (1200 kPa)
ESCUTCHEON	Plain/Flush/Sleeve and Skirt/Extended	Plain/Flush/Sleeve and Skirt/Extended
GLOBE EQUIVALENT	GL5635	GL8135

RECESSED PENDENT QUICK RESPONSE DRY SPRINKLERS		
SIN	V3614	V3616
ORIENTATION	PENDENT	PENDENT
K-FACTOR ¹	5.6 Imp./8.1 S.I.	8.0 Imp./11.5 S.I.
CONNECTION	1" NPT/25mm BSPT/1" IGS	1" NPT/25mm BSPT/1" IGS
MAX WORKING PRESSURE	175 psi (1200 kPa)	175 psi (1200 kPa)
ESCUTCHEON	Recessed	Recessed
GLOBE EQUIVALENT	GL5635	GL8135

AVAILABLE GUARDS/SHIELDS			
SPRINKLER	V34/V36	V36 Intermediate Shield	V34/V36 Int. Shield/Guard
Upright	■		■
Pendent	■	■	

AVAILABLE WRENCHES			
Sprinkler	V36 Recessed	V36 Open End	3/16 Hex Bit (V9)
Upright		■	■
Pendent	■	■	■

Factory Hydrostatic Test: 100% @ 500 psi/3447 kPa/34 bar

Min. Operating Pressure: Pendent: 7 psi/48 kPa/.5 bar
Upright: 12 psi/83 kPa/0.8 bar

Temperature Rating: See tables in section 2.0

¹ For K-Factor when pressure is measured in bar, multiply S.I. units by 10.0.

ALWAYS REFER TO ANY NOTIFICATIONS AT THE END OF THIS DOCUMENT REGARDING PRODUCT INSTALLATION, MAINTENANCE OR SUPPORT.



2.0 CERTIFICATION/LISTINGS

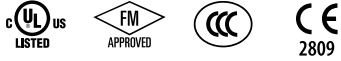

APPROVALS/LISTINGS		
SIN	V3602	V3604
Nominal K Factor Imperial	5.6	8.0
Nominal K Factor S.I. ²	8.1	11.5
Orientation	Upright	Upright
Escutcheon	Plain	Plain
Approved Temperature Ratings F°/C°		
cULus	135°F/57°C 155°F/68°C 200°F/93°C 286°F/141°C	135°F/57°C 155°F/68°C 200°F/93°C 286°F/141°C
FM	135°F/57°C 155°F/68°C 200°F/93°C 286°F/141°C	135°F/57°C 155°F/68°C 200°F/93°C
CCC	155°F/68°C	–

APPROVALS/LISTINGS				
SIN	V3614	V3616	V3614	V3616
Nominal K Factor Imperial	5.6	8.0	5.6	8.0
Nominal K Factor S.I. ²	8.1	11.5	8.1	11.5
Orientation	Pendent	Pendent	Pendent	Pendent
Escutcheon	Plain, Flush, Slv & Skt, Ext	Plain, Flush, Slv & Skt, Ext	Recessed	Recessed
Approved Temperature Ratings F°/C°				
cULus	135°F/57°C 155°F/68°C 200°F/93°C 286°F/141°C	135°F/57°C 155°F/68°C 200°F/93°C 286°F/141°C	135°F/57°C 155°F/68°C 200°F/93°C 286°F/141°C	135°F/57°C 155°F/68°C 200°F/93°C 286°F/141°C
FM	135°F/57°C 155°F/68°C 200°F/93°C 286°F/141°C	135°F/57°C 155°F/68°C 200°F/93°C 286°F/141°C	135°F/57°C 155°F/68°C 200°F/93°C	135°F/57°C 155°F/68°C 200°F/93°C
CCC	155°F/68°C 200°F/93°C 286°F/141°C	155°F/68°C 200°F/93°C 286°F/141°C	155°F/68°C 200°F/93°C 286°F/141°C	155°F/68°C 200°F/93°C 286°F/141°C
CE	135°F/57°C 155°F/68°C 200°F/93°C 286°F/141°C	135°F/57°C 155°F/68°C 200°F/93°C 286°F/141°C	135°F/57°C 155°F/68°C 200°F/93°C	135°F/57°C 155°F/68°C 200°F/93°C

² For K-Factor when pressure is measured in Bar, multiply S.I. units by 10.

NOTES

- Listings and approval as of printing.
- Temperatures are UL Listed for ordinary hazards for V3614 and V3616 dry sprinklers up to 48"/1219mm length.
- CCCf approved for V3614 and V3616 dry sprinklers 79 to 1304 mm/3.1 – 51.3" in length.
- V3616 dry sprinklers are FM-Approved and CE-certified from 5" (127mm) to 30" (762mm) length.
- V3614 and V3616 dry sprinklers with IGS connections are for wet system installation or dry/preaction systems in spaces maintained at 40°F/5°C or greater.

3.0 SPECIFICATIONS – MATERIAL

Deflector: Stainless Steel

Bulb Nominal Diameter: 3.0mm

Split Spacer: Stainless Steel

Load Screw: Brass

Pip Cap: Stainless Steel

Spring Seal Assembly: PTFE coated
Beryllium nickel alloy and stainless steel

Frame: Brass

Inlet Fitting: Brass

Outer Tube: Galvanized steel pipe

Inner Tube: Stainless Steel

Orifice Insert: Stainless Steel

Escutcheon/Plate: 1010 - 1018 mild steel
and stainless steel

Torsion Spring: SST wire

Installation Wrench: Ductile iron

Sprinkler Frame Finishes:

- Plain brass
- Chrome plated
- White painted^{3, 4}
- Bright White painted^{3, 4}
- Flat black painted^{3, 4}
- Custom painted^{3, 4}
- VC-250⁵

³ Not available on the Intermediate Level Style Pendant.

⁴ UL Listed for corrosion resistance.

⁵ UL Listed, FM Approved, and CE-certified for corrosion resistance.

NOTES

- Weather resistant escutcheon available upon request.
- For cabinets and other accessories refer to separate sheet.

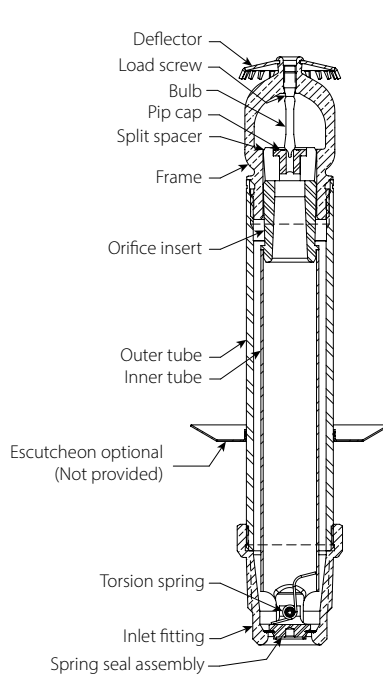

**Material Specifications
V3602, V3604**

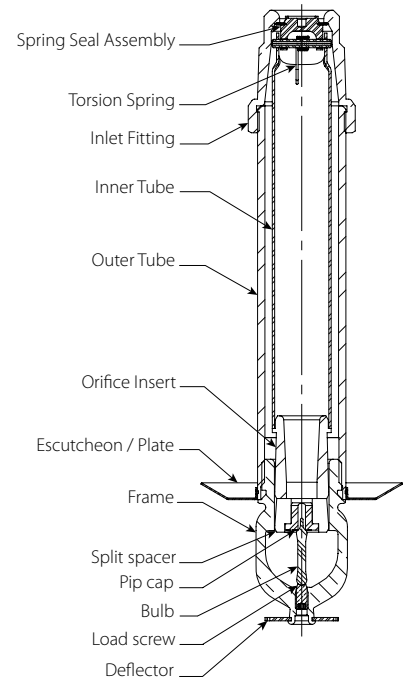

**Material Specifications
V3614, V3616**

4.0 DIMENSIONS

Standard offering includes made-on escutcheon with "A" dimension shown above. Use the "Adjustments for Optional Interchangeable Escutcheons" table when making optional field adjustments to the standard ordered escutcheon.

ADJUSTMENTS FOR INTERCHANGEABLE ESCUTCHEONS	
ESCUTCHEON	"A" DIMENSION ADJUSTMENT
Plain Barrel	A = A
Flush	A = -1/4"/6mm
Recessed	A = +1/4"/6mm
Slv/Skrt	A = -1 3/8"/35mm

NOTE

- See "Dry Sprinkler Installation" section in [I-40: Victaulic FireLock™ Automatic Sprinklers Installation and Maintenance Instructions](#) for specific instructions on connecting to threaded fittings in dry systems.

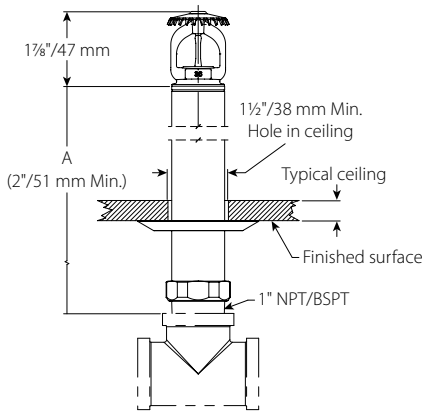

**Installed Dimensions, Threaded
V3602, V3604**

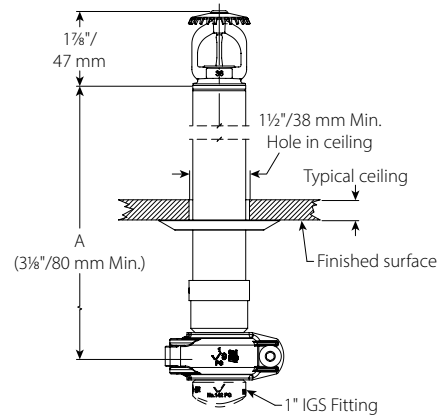

**Installed Dimensions, Grooved
V3602, V3604**

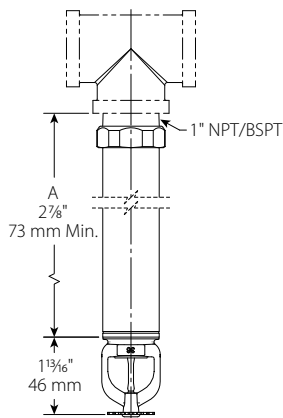

**Plain Barrel, Threaded
V3614, V3616**

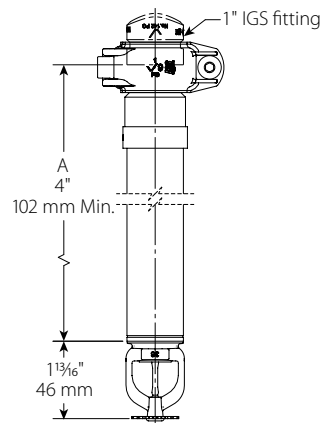

**Plain Barrel, Grooved
V3614, V3616**

4.0 DIMENSIONS (CONTINUED)

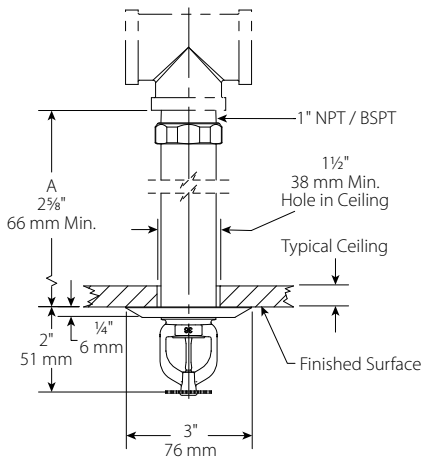

**Flush, Threaded
V3614, V3616**

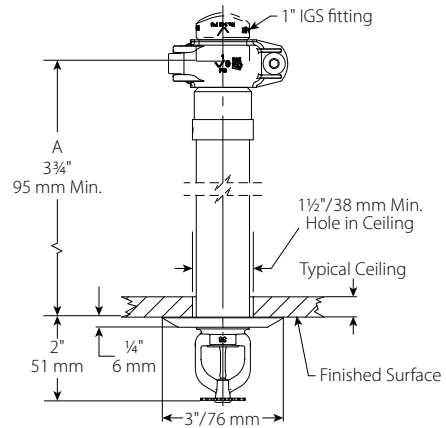

**Flush, Grooved
V3614, V3616**

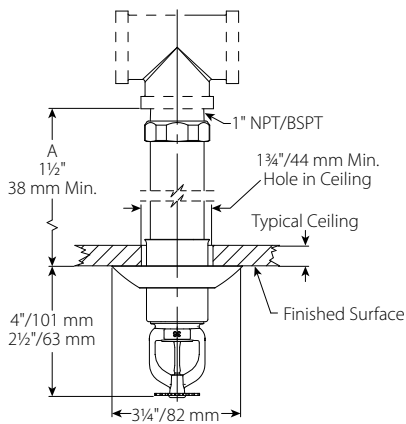

**Sleeve and Skirt, Threaded
V3614, V3616**

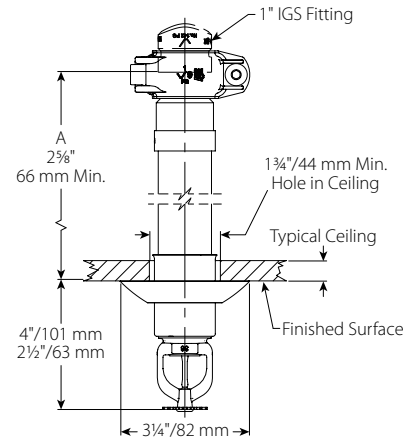

**Sleeve and Skirt, Grooved
V3614, V3616**

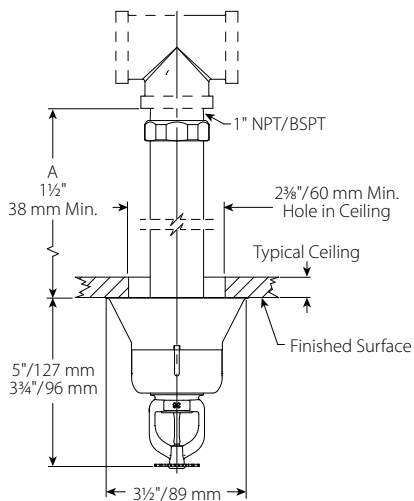

**Extended
Sleeve and Skirt, Threaded
V3614, V3616**

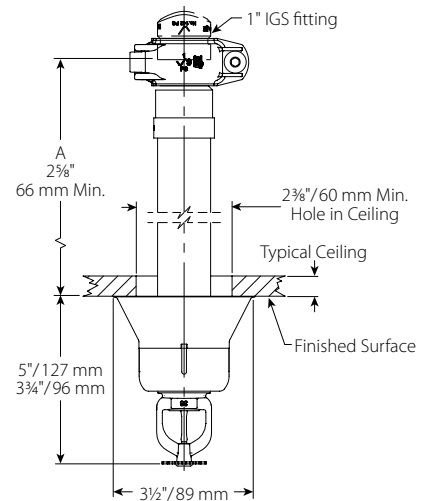

**Extended
Sleeve and Skirt, Grooved
V3614, V3616**

4.0 DIMENSIONS (CONTINUED)

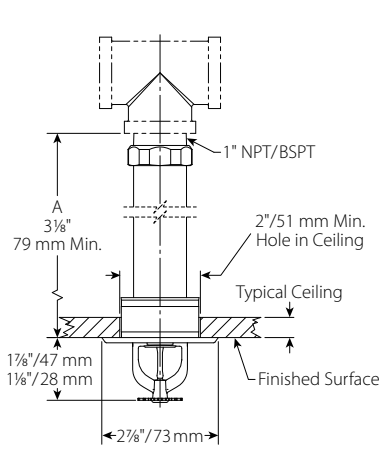

**Recessed, Threaded
V3614, V3616**

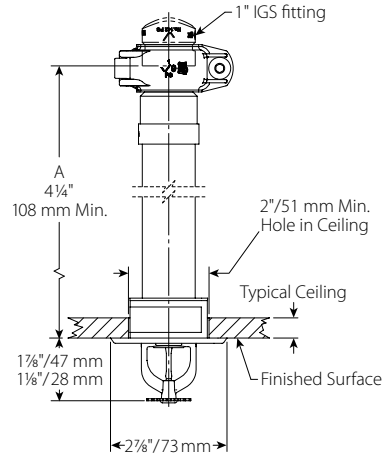

**Recessed, Grooved
V3614, V3616**

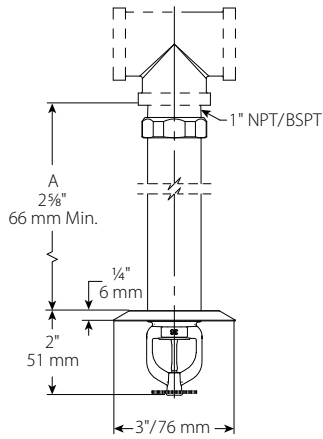

**Intermediate, Threaded
V3614, V3616**

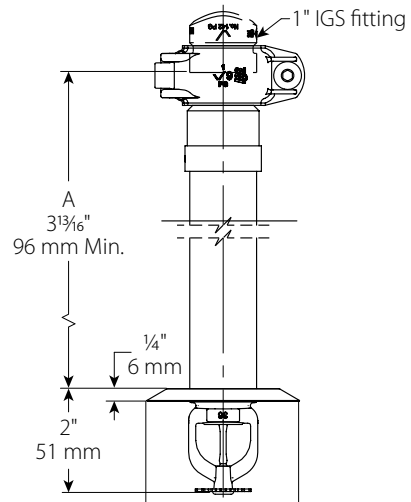

**Intermediate, Grooved
V3614, V3616**

5.0 PERFORMANCE

Sprinkler is to be installed and designed as per NFPA, FM Datasheets, or any local standards.

6.0 NOTIFICATIONS

⚠ WARNING



- Read and understand all instructions before attempting to install any Victaulic products.
- Always verify that the piping system has been completely depressurized and drained immediately prior to installation, removal, adjustment, or maintenance of any Victaulic products.
- Wear safety glasses, hardhat, and foot protection.

Failure to follow these instructions could result in death or serious personal injury and property damage.

- These products shall be used only in fire protection systems that are designed and installed in accordance with current, applicable National Fire Protection Association (NFPA 13, 13D, 13R, etc.) standards, or equivalent standards, and in accordance with applicable building and fire codes. These standards and codes contain important information regarding protection of systems from freezing temperatures, corrosion, mechanical damage, etc.
- The installer shall understand the use of this product and why it was specified for the particular application.
- The installer shall understand common industry safety standards and potential consequences of improper product installation.
- It is the system designer's responsibility to verify suitability of materials for use with the intended fluid media within the piping system and external environment.
- The material specifier shall evaluate the effect of chemical composition, pH level, operating temperature, chloride level, oxygen level, and flow rate on materials to confirm system life will be acceptable for the intended service.

Failure to follow installation requirements and local and national codes and standards could compromise system integrity or cause system failure, resulting in death or serious personal injury and property damage.

7.0 REFERENCE MATERIALS

Ratings: All glass bulbs are rated for temperatures from –67°F/–55°C.

[1-40: Victaulic FireLock™ Automatic Sprinklers Installation and Maintenance Instructions](#)

[I-V9: Style V9 Victaulic FireLock™ IGS™ Installation-Ready™ Sprinkler Coupling Installation Instructions](#)

User Responsibility for Product Selection and Suitability

Each user bears final responsibility for making a determination as to the suitability of Victaulic products for a particular end-use application, in accordance with industry standards and project specifications, and the applicable building codes and related regulations as well as Victaulic performance, maintenance, safety, and warning instructions. Nothing in this or any other document, nor any verbal recommendation, advice, or opinion from any Victaulic employee, shall be deemed to alter, vary, supersede, or waive any provision of Victaulic Company's standard conditions of sale, installation guide, or this disclaimer.

Intellectual Property Rights

No statement contained herein concerning a possible or suggested use of any material, product, service, or design is intended, or should be construed, to grant any license under any patent or other intellectual property right of Victaulic or any of its subsidiaries or affiliates covering such use or design, or as a recommendation for the use of such material, product, service, or design in the infringement of any patent or other intellectual property right. The terms "Patented" or "Patent Pending" refer to design or utility patents or patent applications for articles and/or methods of use in the United States and/or other countries.

Note

This product shall be manufactured by Victaulic or to Victaulic specifications. All products to be installed in accordance with current Victaulic installation/assembly instructions. Victaulic reserves the right to change product specifications, designs and standard equipment without notice and without incurring obligations.

Installation

Reference should always be made to the Victaulic installation handbook or installation instructions of the product you are installing. Handbooks are included with each shipment of Victaulic products, providing complete installation and assembly data, and are available in PDF format on our website at www.victaulic.com.

Warranty

Refer to the Warranty section of the current Price List or contact Victaulic for details.

Trademarks

Victaulic and all other Victaulic marks are the trademarks or registered trademarks of Victaulic Company, and/or its affiliated entities, in the U.S. and/or other countries.

Victaulic® FireLock™ Series FL-QR

Standard Coverage, Quick Response

Upright, Pendent and Recessed Pendent Sprinklers

K2.8 (4.0), K4.2 (6.1), K5.6 (8.1), K8.0 (11.5)



41.01



1.0 PRODUCT DESCRIPTION

QUICK RESPONSE UPRIGHT SPRINKLERS				
SIN	V2815	V4215	V2704	V3402
ORIENTATION	UPRIGHT	UPRIGHT	UPRIGHT	UPRIGHT
K-FACTOR ¹	2.8 Imp./4.0 S.I.	4.2 Imp./6.1 S.I.	5.6 Imp./8.1 S.I.	8.0 Imp./11.5 S.I.
CONNECTION	½" NPT/15mm BSPT	½" NPT/15mm BSPT	½" NPT/15mm BSPT/IGS	¾" NPT/20mm BSPT/IGS
MAX. WORKING PRESSURE	175 psi/1200 kPa	175 psi/1200 kPa	175 psi/1200 kPa cULus 250 psi/1725 kPa	175 psi/1200 kPa
GLOBE RE-DESIGNATION	GL2815	GL4215	-	-
GLOBE EQUIVALENT	-	-	GL5615	GL8118

QUICK RESPONSE PENDENT SPRINKLERS				
SIN	V2801	V4201	V2708	V3406
ORIENTATION	PENDENT	PENDENT	PENDENT	PENDENT
K-FACTOR ¹	2.8 Imp./4.0 S.I.	4.2 Imp./6.1 S.I.	5.6 Imp./8.1 S.I.	8.0 Imp./11.5 S.I.
CONNECTION	½" NPT/15mm BSPT	½" NPT/15mm BSPT	½" NPT/15mm BSPT/IGS	¾" NPT/20mm BSPT/IGS
MAX. WORKING PRESSURE	175 psi/1200 kPa	175 psi/1200 kPa	175 psi/1200 kPa cULus 250 psi/1725 kPa	175 psi/1200 kPa
GLOBE RE-DESIGNATION	GL2801	GL4201	-	-
GLOBE EQUIVALENT	-	-	GL5601	GL8101

QUICK RESPONSE RECESSED PENDENT SPRINKLERS				
SIN	V2801	V4201	V2708	V3406
ORIENTATION	PENDENT	PENDENT	PENDENT	PENDENT
K-FACTOR ¹	2.8 Imp./4.0 S.I.	4.2 Imp./6.1 S.I.	5.6 Imp./8.1 S.I.	8.0 Imp./11.5 S.I.
CONNECTION	½" NPT/15mm BSPT	½" NPT/15mm BSPT	½" NPT/15mm BSPT/IGS	¾" NPT/20mm BSPT/IGS
MAX. WORKING PRESSURE	175 psi/1200 kPa	175 psi/1200 kPa	175 psi/1200 kPa cULus 250 psi/1725 kPa	175 psi/1200 kPa
ESCUTCHEON	Recessed	Recessed	Recessed	Recessed
GLOBE RE-DESIGNATION	GL2801	GL4201	-	-
GLOBE EQUIVALENT	-	-	GL5601	GL8101

AVAILABLE GUARDS/SHIELDS				
SPRINKLER	V28	V42	V27	V34
Upright			■	■
Pendent			■	■

AVAILABLE WRENCHES							
SPRINKLER	V56-2 Recessed	V56 Open End	V27-2 Recessed	V27 Open End	V34-2 Recessed	V34 Open End	⅜ Hex-Bit
V2815 and V4215		■					
V2707 and V2704				■			■
V3402						■	■
V2801, and V4201	■	■					
V2706 and V2708			■	■			■
V3406					■	■	■

Factory Hydrostatic Test: 100% @ 500 psi/3447 kPa/34 bar

Min. Operating Pressure: UL/FM: 7 psi/48 kPa/.5 bar
VdS: 5 psi/35 kPa/.35 bar (Upright only)

Temperature Rating: See tables in section 2.0

¹ For K-Factor when pressure is measured in bar, multiply S.I. units by 10.0.

ALWAYS REFER TO ANY NOTIFICATIONS AT THE END OF THIS DOCUMENT REGARDING PRODUCT INSTALLATION, MAINTENANCE OR SUPPORT.



2.0 CERTIFICATION/LISTINGS



UPRIGHT APPROVALS/LISTINGS				
SIN	V2815	V4215	V2704	V3402
Nominal K Factor Imperial	2.8	4.2	5.6	8.0
Nominal K Factor S.I. ²	4.0	6.1	8.1	11.5
Orientation	UPRIGHT	UPRIGHT	UPRIGHT	UPRIGHT
Approved Temperature Ratings F°/C°				
cULus	135°F/57°C 155°F/68°C 175°F/79°C 200°F/93°C 286°F/141°C	135°F/57°C 155°F/68°C 175°F/79°C 200°F/93°C 286°F/141°C	135°F/57°C 155°F/68°C 175°F/79°C 200°F/93°C 286°F/141°C	135°F/57°C 155°F/68°C 175°F/79°C 200°F/93°C 286°F/141°C
FM	-	-	135°F/57°C 155°F/68°C 175°F/79°C 200°F/93°C 286°F/141°C	135°F/57°C 155°F/68°C 175°F/79°C 200°F/93°C 286°F/141°C
LPCB	-	-	135°F/57°C 155°F/68°C 175°F/79°C 200°F/93°C 286°F/141°C	135°F/57°C 155°F/68°C 175°F/79°C 200°F/93°C 286°F/141°C
CE, UKCA	-	-	135°F/57°C 155°F/68°C 175°F/79°C 200°F/93°C 286°F/141°C	135°F/57°C 155°F/68°C 175°F/79°C 200°F/93°C 286°F/141°C
VdS	-	-	135°F/57°C 155°F/68°C 175°F/79°C 200°F/93°C 286°F/141°C	135°F/57°C 155°F/68°C 175°F/79°C 200°F/93°C 286°F/141°C
CCC K-ZSTZ	-	-	155°F/68°C 175°F/79°C 286°F/141°C	155°F/68°C 286°F/141°C

² For K-Factor when pressure is measured in Bar, multiply S.I. units by 10.

PENDENT APPROVALS/LISTINGS				
SIN	V2801	V4201	V2708	V3406
Nominal K Factor Imperial	2.8	4.2	5.6	8.0
Nominal K Factor S.I. ²	4.0	6.1	8.1	11.5
Orientation	PENDENT	PENDENT	PENDENT	PENDENT
Escutcheon	Flush/Extended	Flush/Extended	Flush/Extended	Flush/Extended
Approved Temperature Ratings F°/C°				
cULus	135°F/57°C 155°F/68°C 175°F/79°C 200°F/93°C 286°F/141°C	135°F/57°C 155°F/68°C 175°F/79°C 200°F/93°C 286°F/141°C	135°F/57°C 155°F/68°C 175°F/79°C 200°F/93°C 286°F/141°C	135°F/57°C 155°F/68°C 175°F/79°C 200°F/93°C 286°F/141°C
FM	-	-	135°F/57°C 155°F/68°C 175°F/79°C 200°F/93°C 286°F/141°C	135°F/57°C 155°F/68°C 175°F/79°C 200°F/93°C 286°F/141°C
CCC K-ZSTX	-	-	155°F/68°C 200°F/93°C 286°F/141°C	155°F/68°C 286°F/141°C

² For K-Factor when pressure is measured in Bar, multiply S.I. units by 10.

NOTES

- Listings and approval as of printing.
- Where cULus Listed, Polyester and VC-250 Coatings Listed as Corrosion Resistant (V3402 with VC-250 Only)
- Where FM Approved, VC-250 Coating Approved as Corrosion Resistant
- New York City Acceptance - All UL Listed and/or FM Approved sprinklers acceptable to NYC per section 28-113 of the Administrative Code and the OTCR Rule.

2.0 CERTIFICATION/LISTINGS (CONTINUED)

RECESSED PENDENT APPROVALS/LISTINGS				
SIN	V2801	V4201	V2708	V3406
Nominal K Factor Imperial	2.8	4.2	5.6	8.0
Nominal K Factor S.I. ²	4.0	6.1	8.1	11.5
Orientation	PENDENT	PENDENT	PENDENT	PENDENT
Escutcheon	Recessed	Recessed	Recessed	Recessed
Approved Temperature Ratings F°/C°				
cULus	135°F/57°C 155°F/68°C 175°F/79°C 200°F/93°C 286°F/141°C	135°F/57°C 155°F/68°C 175°F/79°C 200°F/93°C 286°F/141°C	135°F/57°C 155°F/68°C 175°F/79°C 200°F/93°C	135°F/57°C 155°F/68°C 175°F/79°C 200°F/93°C 286°F/141°C
FM WITH ½" ADJUSTMENT ESCUTCHEON ONLY	-	-	135°F/57°C 155°F/68°C 175°F/79°C 200°F/93°C	135°F/57°C 155°F/68°C 175°F/79°C 200°F/93°C
CCC K-ZSTX	-	-	155°F/68°C 200°F/93°C 286°F/141°C	155°F/68°C 286°F/141°C

² For K-Factor when pressure is measured in Bar, multiply S.I. units by 10.

NOTES

- Listings and approval as of printing.
- Where cULus Listed, Polyester and VC-250 Coatings Listed as Corrosion Resistant (V3402 with VC-250 Only)
- Where FM Approved, VC-250 Coating Approved as Corrosion Resistant
- New York City Acceptance - All UL Listed and/or FM Approved sprinklers acceptable to NYC per section 28-113 of the Administrative Code and the OTCR Rule.

3.0 SPECIFICATIONS – MATERIAL

Deflector: Bronze

Bulb Nominal Diameter: 3.0mm

Load Screw: Bronze

Pip Cap: Bronze

Spring Seal: PTFE coated Beryllium nickel alloy

Frame: Brass

Lodgement Spring: Stainless steel

Installation Wrench: Ductile iron

Sprinkler Frame Finishes:

- Plain brass
- Chrome plated
- White polyester painted^{3, 4}
- Flat black polyester painted^{3, 4}
- Custom polyester painted^{3, 4}
- VC-250⁵

³ Not available on the Intermediate Level Style Pendant.

⁴ UL Listed for corrosion resistance.

⁵ UL Listed and FM Approved for corrosion resistance.

NOTE

- For cabinets and other accessories refer to separate sheet.

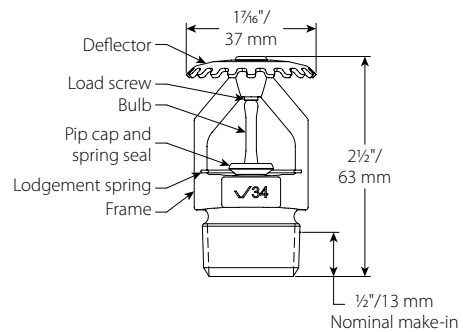
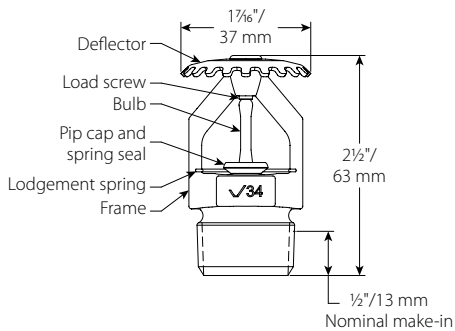
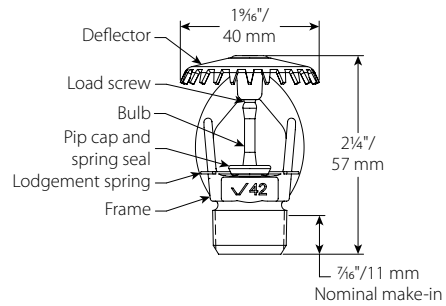
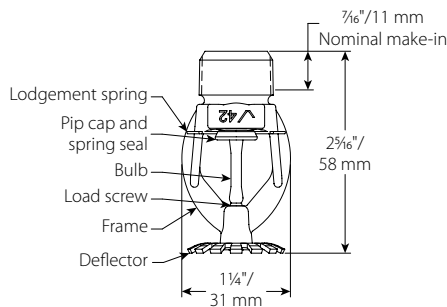
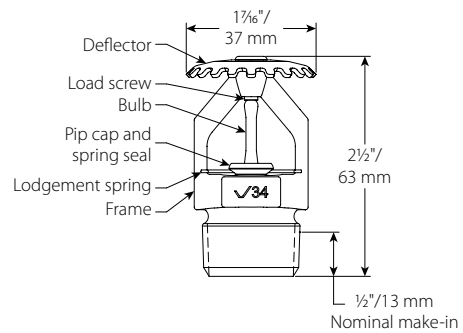
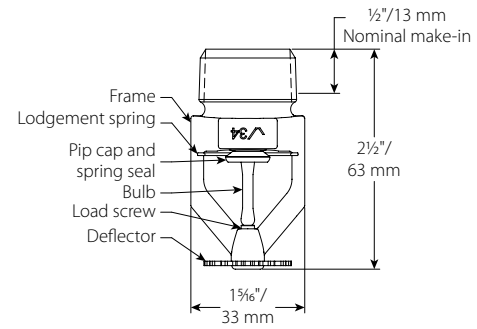

4.0 DIMENSIONS

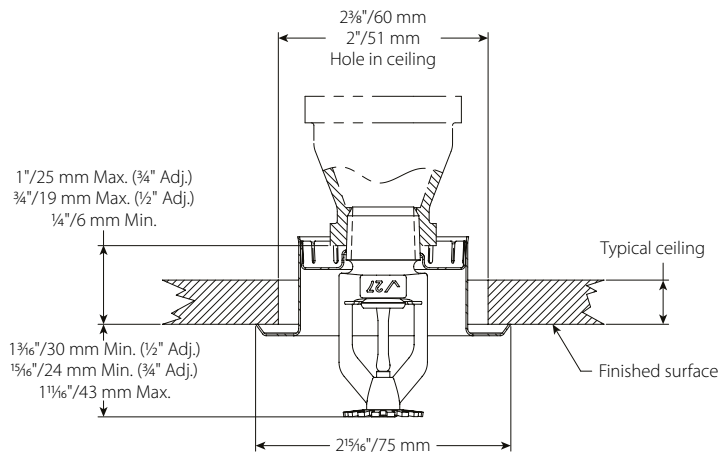
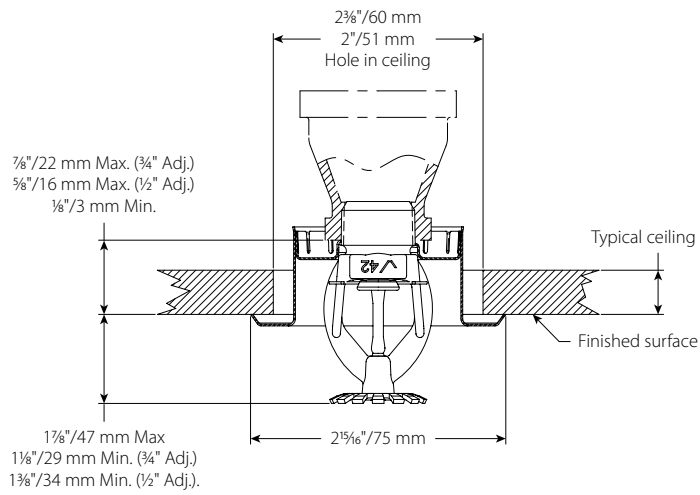
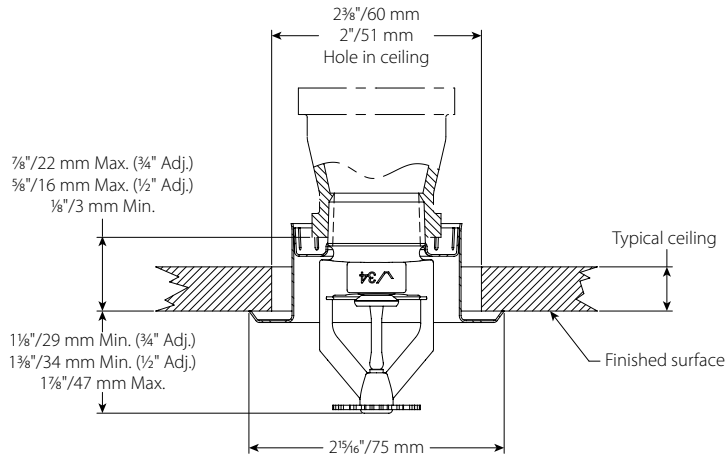

5.0 PERFORMANCE

Sprinkler is to be installed and designed as per NFPA, FM Datasheets, or any local standards.

6.0 NOTIFICATIONS

⚠ WARNING	
	<ul style="list-style-type: none"> • Read and understand all instructions before attempting to install any Victaulic products. • Always verify that the piping system has been completely depressurized and drained immediately prior to installation, removal, adjustment, or maintenance of any Victaulic products. • Wear safety glasses, hardhat, and foot protection. <p>Failure to follow these instructions could result in death or serious personal injury and property damage.</p>
<ul style="list-style-type: none"> • These products shall be used only in fire protection systems that are designed and installed in accordance with current, applicable National Fire Protection Association (NFPA 13, 13D, 13R, etc.) standards, or equivalent standards, and in accordance with applicable building and fire codes. These standards and codes contain important information regarding protection of systems from freezing temperatures, corrosion, mechanical damage, etc. • The installer shall understand the use of this product and why it was specified for the particular application. • The installer shall understand common industry safety standards and potential consequences of improper product installation. • It is the system designer's responsibility to verify suitability of materials for use with the intended fluid media within the piping system and external environment. • The material specifier shall evaluate the effect of chemical composition, pH level, operating temperature, chloride level, oxygen level, and flow rate on materials to confirm system life will be acceptable for the intended service. <p>Failure to follow installation requirements and local and national codes and standards could compromise system integrity or cause system failure, resulting in death or serious personal injury and property damage.</p>	

7.0 REFERENCE MATERIALS

Ratings: All glass bulbs are rated for temperatures from -67°F/-55°C to those shown in the table below.

[I-40: Victaulic FireLock™ Automatic Sprinklers Installation and Maintenance Instructions](#)

[I-V9: Style V9 Victaulic FireLock™ IGS™ Installation-Ready™ Sprinkler Coupling Installation Instructions](#)

User Responsibility for Product Selection and Suitability

Each user bears final responsibility for making a determination as to the suitability of Victaulic products for a particular end-use application, in accordance with industry standards and project specifications, as well as Victaulic performance, maintenance, safety, and warning instructions. Nothing in this or any other document, nor any verbal recommendation, advice, or opinion from any Victaulic employee, shall be deemed to alter, vary, supersede, or waive any provision of Victaulic Company's standard conditions of sale, installation guide, or this disclaimer.

Intellectual Property Rights

No statement contained herein concerning a possible or suggested use of any material, product, service, or design is intended, or should be construed, to grant any license under any patent or other intellectual property right of Victaulic or any of its subsidiaries or affiliates covering such use or design, or as a recommendation for the use of such material, product, service, or design in the infringement of any patent or other intellectual property right. The terms "Patented" or "Patent Pending" refer to design or utility patents or patent applications for articles and/or methods of use in the United States and/or other countries.

Note

This product shall be manufactured by Victaulic or to Victaulic specifications. All products to be installed in accordance with current Victaulic installation/assembly instructions. Victaulic reserves the right to change product specifications, designs and standard equipment without notice and without incurring obligations.

Installation

Reference should always be made to the Victaulic installation handbook or installation instructions of the product you are installing. Handbooks are included with each shipment of Victaulic products, providing complete installation and assembly data, and are available in PDF format on our website at www.victaulic.com.

Warranty

Refer to the Warranty section of the current Price List or contact Victaulic for details.

Trademarks

Victaulic and all other Victaulic marks are the trademarks or registered trademarks of Victaulic Company, and/or its affiliated entities, in the U.S. and/or other countries.



TECHNICAL DATA

MODEL V-BB SPECIFIC APPLICATION ATTIC SPRINKLER

The Viking Corporation, 210 N Industrial Park Drive, Hastings MI 49058

Telephone: 269-945-9501 Technical Services: 877-384-5464 Fax: 269-818-1680 Email: techsvcs@vikingcorp.com

Visit the Viking website for the latest edition of this technical data page www.vikinggroupinc.com.

1. DESCRIPTION

The Model V-BB (Back to Back) is a Specific Application Attic Sprinkler designed to provide superior fire protection in combustible and non-combustible sloped attic spaces when compared to standard spray attic protection. With specific application criteria for use with Model V-SD (Single Directional) and VK696 Attic Upright Specific Application Sprinklers, Viking attic sprinklers provide an extended coverage spacing alternative to standard spray sprinklers. They make it possible to use a single line of piping at the attic peak, eliminating the need for branch lines and greatly reducing the number of required sprinklers and associated material and installation costs. Model V-BB sprinklers also have lower minimum flow and pressure requirements than competitive products.

Viking Attic Sprinklers can be installed with either steel or CPVC piping (CPVC allowed on wet pipe systems only), and are available in brass or with corrosion-resistant Electroless Nickel PTFE (ENT) coatings where salt water and other corrosive elements are a consideration. They are cULus Listed with specific application guidelines for use as special sprinklers as defined by the National Fire Protection Association (NFPA), and are cULus Listed for extended coverage in combustible and non-combustible construction. The cULus Listing was achieved using full-scale fire tests within wood truss construction.

The Model V-BB Attic Sprinkler provides a reduced response time due to its narrow ridge spacing of 6 ft. (1,8 m) and long throw pattern (up to 30 ft. in each direction measured horizontally), and is offered in three different slope ranges and two different orifice sizes (K=5.6 or 8.0). Listed for specific pitches 4:12<7:12, 7:12<10:12, and 10:12≤12:12; and spans of 60 ft. and 40 ft. The 8.0K can protect up to 80 ft. span when used along with the Model Attic Upright VK696.

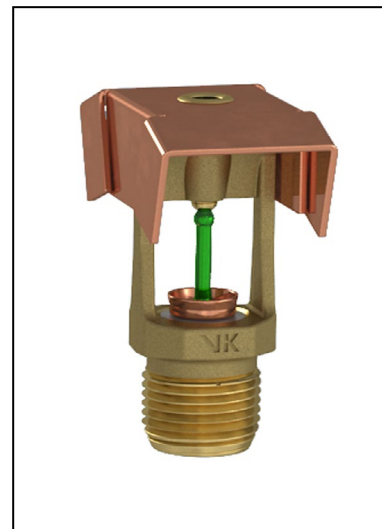

V-BB Sprinkler

8.0K	5.6K	Pitch
VK681	VK684	4:12 < 7:12
VK682	VK685	7:12 < 10:12
VK683	VK686	10:12 ≤ 12:12

2. LISTINGS AND APPROVALS



cULus Listed: Category VN1V

Refer to the Approval Chart on page 4.

3. TECHNICAL DATA

Specifications:

Minimum Operating Pressure: See Design Criteria - UL

Rated to 175 psi (12 bar) water working pressure

Factory tested hydrostatically to 500 psi (34.5 bar)

Thread size: 1/2" (15 mm) or 3/4" (19 mm) NPT

Nominal K-Factor: 5.6 U.S. (80.6 metric*) or 8.0 (115.2 metric*)

* Metric K-factor measurement shown is when pressure is measured in Bar. When pressure is measured in kPa, divide the metric K-factor shown by 10.0.

Glass-bulb fluid temperature rated to -65 °F (-55 °C)

Overall Length: 2-5/8" (67,6 mm)

Covered by the following US Patent No.: 9,149,818

Material Standards:

Frame Casting: Brass UNS-C84400 or QM Brass

Deflector: Brass UNS-C23000

Bulb: Glass, nominal 3 mm diameter

Belleville Spring Sealing Assembly: Nickel Alloy, coated on both sides with Teflon Tape

Screw: Brass UNS-C36000

Pip Cap and Insert Assembly: Copper UNS-C11000 and Stainless Steel UNS-S30400

Ordering Information: (Also refer to the current Viking price list.)

To order the Attic Sprinkler, add the appropriate suffix for the sprinkler finish and then the appropriate suffix for the temperature rating to the sprinkler base part number.

Finish Suffix: Brass = A, ENT = JN

Temperature Suffix: E = 200 °F (93.3 °C)

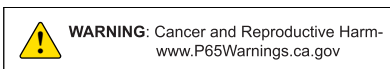

WARNING: Cancer and Reproductive Harm-
www.P65Warnings.ca.gov



TECHNICAL DATA

MODEL V-BB SPECIFIC APPLICATION ATTIC SPRINKLER

The Viking Corporation, 210 N Industrial Park Drive, Hastings MI 49058

Telephone: 269-945-9501 Technical Services: 877-384-5464 Fax: 269-818-1680 Email: techsvcs@vikingcorp.com

Visit the Viking website for the latest edition of this technical data page www.vikinggroupinc.com.

Available Finishes And Temperature Ratings:

Refer to the approval chart on page 4.

Accessories: (Also refer to the "Sprinkler Accessories" section of the Viking website under Technical Data)

Sprinkler Wrench:

Standard Wrench: Part No. 10896W/B

Sprinkler Cabinets:

A. Six-head capacity: Part No. 01724A

B. Twelve-head capacity: Part No. 01725A

4. INSTALLATION

Refer to appropriate NFPA Installation Standards.

5. OPERATION

During a fire condition, the heat sensitive liquid in the glass bulb expands, causing the glass to shatter, releasing the pip cap and sealing spring assembly. Water flowing through the sprinkler orifice strikes the deflector, forming a uniform spray pattern to extinguish or control the fire, and protect the piping in the interstitial space.

6. INSPECTIONS, TESTS AND MAINTENANCE

Refer to NFPA 25 for Inspection, Testing and Maintenance requirements.

7. AVAILABILITY

The Model V-BB Specific Application Sprinkler is available through a network of domestic and international distributors. See The Viking Corporation web site for the closest distributor or contact The Viking Corporation.

8. GUARANTEE

For details of warranty, refer to Viking's current list price schedule or contact Viking directly.

TABLE 1: AVAILABLE SPRINKLER TEMPERATURE RATINGS AND FINISHES

Sprinkler Temperature Classification	Sprinkler Nominal Temperature Rating ¹	Maximum Ambient Ceiling Temperature ²	Bulb Color
Intermediate	200 °F (93.3 °C)	150 °F (65°C)	Green

Sprinkler Finishes: Brass, ENT³

Footnotes

¹ The sprinkler temperature rating is stamped on the deflector.

² Based on NFPA-13. Other limits may apply, depending on fire loading, sprinkler location, and other requirements of the Authority Having Jurisdiction. Refer to specific installation standards.

³ cULus Listed as corrosion resistant.



TECHNICAL DATA

**MODEL V-BB
SPECIFIC APPLICATION
ATTIC SPRINKLER**

The Viking Corporation, 210 N Industrial Park Drive, Hastings MI 49058
 Telephone: 269-945-9501 Technical Services: 877-384-5464 Fax: 269-818-1680 Email: techsvcs@vikingcorp.com
 Visit the Viking website for the latest edition of this technical data page www.vikinggroupinc.com.

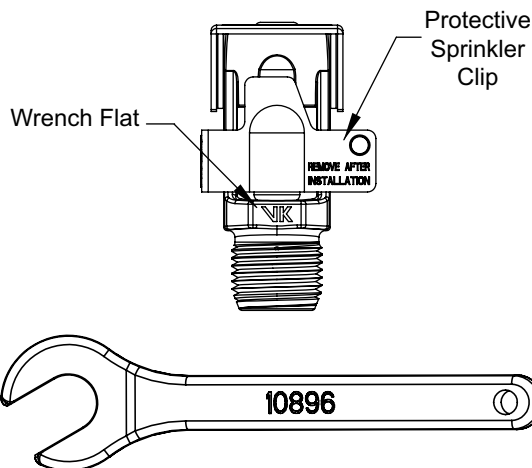

**Figure 1:
Standard Sprinkler Wrench 10896W/B**

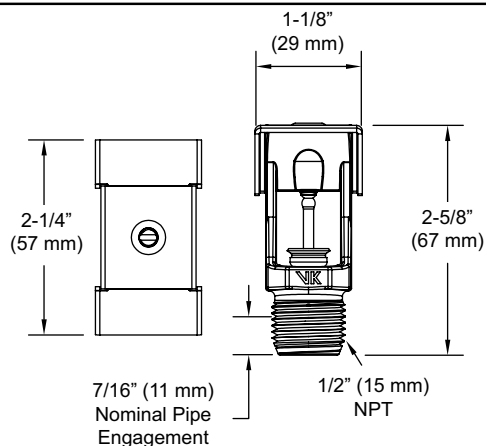

**Figure 2a:
Sprinkler Dimensions - 5.6K**

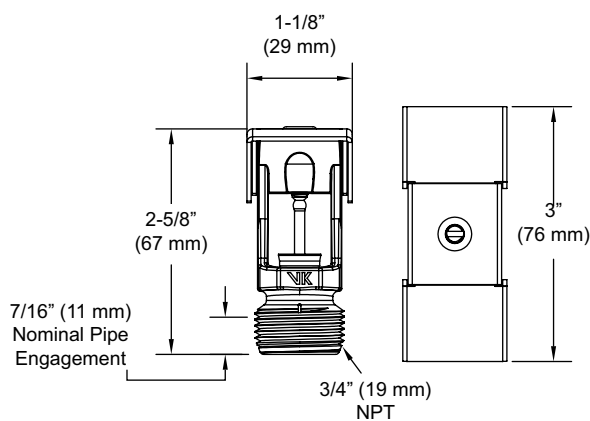

**Figure 2b:
Sprinkler Dimensions - 8.0K**



TECHNICAL DATA

MODEL V-BB SPECIFIC APPLICATION ATTIC SPRINKLER

The Viking Corporation, 210 N Industrial Park Drive, Hastings MI 49058
 Telephone: 269-945-9501 Technical Services: 877-384-5464 Fax: 269-818-1680 Email: techsvcs@vikingcorp.com
 Visit the Viking website for the latest edition of this technical data page www.vikinggroupinc.com.

Approval Chart 1

Viking V-BB Specific Application Sprinkler
 For Combustible and Non-Combustible Sloped Attic Spaces

KEY	
Temperature	↓
Finish	←
A1X ← Escutcheon (if applicable)	

Part Number ¹	SIN	Maximum Pressure	Thread Size		Nominal K-Factor		Overall Length		Listings and Approvals ³				
			NPT	BSP	U.S.	metric ²	Inches	mm	cULus ⁴	FM	LPCB	CE	⚙
19627	VK684	175 psi	1/2"	15 mm	5.6	80,6	2-5/8	68	A1, A2	--	--	--	--
19801	VK685	175 psi	1/2"	15 mm	5.6	80,6	2-5/8	68	A1, A2	--	--	--	--
19754	VK686	175 psi	1/2"	15 mm	5.6	80,6	2-5/8	68	A1, A2	--	--	--	--
19626	VK681	175 psi	3/4"	20 mm	8.0	115,2	2-5/8	68	A1, A2	--	--	--	--
19798	VK682	175 psi	3/4"	20 mm	8.0	115,2	2-5/8	68	A1, A2	--	--	--	--
19751	VK683	175 psi	3/4"	20 mm	8.0	115,2	2-5/8	68	A1, A2	--	--	--	--
Approved Temperature Rating							Approved Finishes						
A - 200 °F (93.3 °C)							1 - Brass, 2 - ENT ⁵						

¹ Also refer to Viking's current price schedule.

² Metric K-factor measurement shown is when pressure is measured in Bar. When pressure is measured in kPa, divide the metric K-factor shown by 10.0.

³ This table shows the listings and approvals available at the time of printing. Other approvals may be in process.

⁴ Listed by Underwriters Laboratories Inc for use in the United States and Canada.

⁵ cULus Listed as corrosion resistant.

DESIGN CRITERIA - UL Chart 1

(Also refer to Approval Chart 1)
 Allowable , flow, pressure and slope for attic protection using Viking V-BB Sprinklers

Sprinkler Base Part Number	SIN	Type	Thread Size		Nominal K-Factor		Allowable Roof Span ² ft. (m)	Minimum Flow		Minimum Pressure		Pitch ¹	Dry Pipe System Maximum Water Delivery Time ³ (in seconds)
			NPT	BSP	U.S.	metric		GPM	LPM	PSI	BAR		
19627	VK684	V-BB	1/2"	15 mm	5.6	80,6	≤40 (12,2)	24	91	18.4	1,3	4:12 < 7:12	See footnote 3
19801	VK685	V-BB	1/2"	15 mm	5.6	80,6	≤40 (12,2)	24	91	18.4	1,3	7:12 < 10:12	See footnote 3
19754	VK686	V-BB	1/2"	15 mm	5.6	80,6	≤40 (12,2)	24	91	18.4	1,3	10:12 ≤ 12:12	See footnote 3
19626	VK681	V-BB	3/4"	20 mm	8.0	115,2	≤60 (18,3)	38	144	22.6	1,5	4:12 < 7:12	See footnote 3
19798	VK682	V-BB	3/4"	20 mm	8.0	115,2	≤60 (18,3)	38	144	22.6	1,5	7:12 < 10:12	See footnote 3
19751	VK683	V-BB	3/4"	20 mm	8.0	115,2	≤60 (18,3)	38	144	22.6	1,5	10:12 ≤12:12	See footnote 3

¹ Pitch and slope indicate the incline of a roof, expressed as a proportion of the vertical to the horizontal.

² Refer to the Viking Attic Upright VK696 data sheet for roof spans over 60 ft (18,29 m) up to 80 ft (24,38 m) wide.

³ Refer to NFPA 13, 2013, Section 7.2.3.

IMPORTANT: Always refer to Bulletin Form No. F_091699 - Care and Handling of Sprinklers. Also refer to page SR1-3 for general care, installation, and maintenance information. Viking sprinklers are to be installed in accordance with the latest edition of Viking technical data, the appropriate standards of NFPA, LPCB, APSAD, VdS or other similar organizations, and also with the provisions of governmental codes, ordinances, and standards, whenever applicable.



TECHNICAL DATA

MODEL V-BB SPECIFIC APPLICATION ATTIC SPRINKLER

The Viking Corporation, 210 N Industrial Park Drive, Hastings MI 49058

Telephone: 269-945-9501 Technical Services: 877-384-5464 Fax: 269-818-1680 Email: techsvcs@vikingcorp.com

Visit the Viking website for the latest edition of this technical data page www.vikinggroupinc.com.

ADDITIONAL DESIGN CRITERIA - UL Chart 2

(Also refer to DESIGN CRITERIA Chart 1)

Allowable roof span, flow, pressure and slope for attic protection using Viking V-BB Sprinklers

Design Criteria: Flow and Pressures refer to Design Chart 1.

System Type:

Wet systems and dry systems.

Antifreeze Systems:

Use only listed antifreeze in accordance with the applicable NFPA standard as follows:

Option 1: Use any listed antifreeze in accordance with the manufacturer's installation instructions.

Option 2: For a Light Hazard Unoccupied attic

1. System Volume ≤ 200 gal (764 L)
2. Use freezemaster™ antifreeze (refer to Manufacturer's documentation)
3. Viking Attic Sprinklers (V-BB, V-HIP, V-SD, VK696, VK697)
4. Calculate the number of sprinklers in the hydraulically remote area in accordance with wet system criteria.*

* **NOTE:** For systems greater than 40 Gal (151 L), pipe sizing shall be determined using both the Darcy-Weisbach and Hazen-Williams approved hydraulic calculations. Because of the density of freezemaster™ antifreeze, the K-factor must be adjusted, and the friction loss must be considered in the system design.

Piping Types:

Steel (wet and dry) CPVC (wet systems only).

Occupancy Classification: Light hazard only.

Viking V-BB Sprinkler Spacing

Maximum Coverage Area:

400 ft² (37,16 m²) as measured along the slope.

Coverage area is determined by the twice the maximum distance thrown measured along the slope, multiplied by the distance along the branch line.

Example: 60' (18,3 m) span with a 10:12 slope, when measured along the slope provides a distance of approximately 39'-1" (11,9 m). This number must be multiplied by 2 to equal the overall span, which would be approximately 78'-2" (23,8 m). 400 ft² divided by 78'-2" (23,8 m) allows a maximum spacing along the branchline of 5'-1" (15,5 m).

Along the Branch Line:

Minimum Spacing: 4'-0" (1,2 m) between V-BB's and from V-SD's. 7'-0" (2,1 m) from Viking Attic Uprights. 6'-0" (1,8 m) from Standard Spray Sprinklers

Maximum Spacing: 6'-0" (1,8 m) between V-BB's and from V-SD's.

Measured Down the Slope:

Minimum Spacing: 26'-0" (7,9 m) from Viking Attic Uprights and Standard Spray Sprinklers.

Deflector Position below Peak, Ridge, or Deck:

For all roof pitches as per the listing from 4:12 – 12:12 the maximum deflector distance down is 22" (560 mm), and the minimum deflector distance down is 16" (405 mm).

Deflector Position above Scissor Truss:

For all roof pitches as per the listing from 4:12 – 12:12 the minimum distance above a scissor truss is 18" (458 mm).

Maximum distance from center line of the ridge:

6" (152 mm) on either side of the center line.

Minimum distance from Truss:

6" (152 mm) from nearest edge of the truss.

Draft Curtains:

Where used to allow Attic Upright Sprinkler installation shall be constructed to contain heat, may be constructed of minimum 1/2" (13 mm) plywood or equivalent.

Continues on next page.



TECHNICAL DATA

MODEL V-BB SPECIFIC APPLICATION ATTIC SPRINKLER

The Viking Corporation, 210 N Industrial Park Drive, Hastings MI 49058

Telephone: 269-945-9501 Technical Services: 877-384-5464 Fax: 269-818-1680 Email: techsvcs@vikingcorp.com

Visit the Viking website for the latest edition of this technical data page www.vikinggroupinc.com.

Continued from previous page.

Use of UL Listed CPVC Blazemaster Piping (Wet Systems Only):

Can be used to supply the sprinklers protecting the floor below the combustible concealed space when covered with 6" (152 mm) of non-combustible insulation over the horizontal or vertical piping, and extending 12" (304 mm) on both sides of the center line of the piping. If the piping is located in the joist, the width of the joist channel must be entirely covered to 6" (152 mm) above the top of the piping. The area above the piping must be protected with the Model V-BB's, V-SD's, or the Attic Upright Sprinklers.

Listed CPVC Blazemaster piping may also be used exposed to feed wet systems using Viking V-BB sprinklers in accordance with the following requirements, and in accordance with Figure 15:

- Risers are vertical and protected by V-BB or V-SD sprinklers located a maximum of 12 (304 mm)" away from the riser centerline.
- Model V-BB or V-SD sprinklers are mounted directly to the branchline.
- Model V-BB or V-SD sprinklers are installed on arm-overs a maximum of 6" (152 mm) laterally from the center line of the branch line.
- Model V-BB or V-SD sprinklers are installed on Vertical Sprigs attached to the branchline.
- Model V-BB or V-SD sprinklers are installed on angled sprigs a maximum of 6" (152 mm) laterally from the centerline of the branchline.
- Installed with a minimum lateral distance of 18" (456 mm) from any device that produces and releases heat, i.e. attic furnace, kitchen or bathroom exhaust fan, flue vents, heat lamps, and other such devices.

NOTICE

Insulation requirements are provided solely for Fire Protection purposes and not for freeze protection.

NOTICE

Non-combustible insulation being used needs to be verified for chemical compatibility with the CPVC piping at www.lubrizol.com

Obstruction Criteria:

Refer to Figures 4—14

Refer to Sections 8.8.5.2.1.3 and 8.8.5.2.1.7 of NFPA 13, 2013 for requirements if installed on greater than 2-1/2" (64 mm) diameter piping.

Hydraulic Requirements:

Viking V-BB Sprinklers must be calculated in accordance with the following figures and guidelines.

The design area shall include the most hydraulically demanding sprinklers, and in certain cases may require more than one set of calculations to verify the system's design.

The following figures cover Hydraulic Requirements for Viking V-BB Sprinklers only, and when installed with Attic Upright or Standard Spray Sprinklers.

For areas using Viking V-SD Sprinklers refer to the applicable data sheets.

Refer to Figures-unless otherwise noted, all Figures portray a 60' (18,3 m) roof span:

Figure 16 – V-BB Sprinklers

Figure 17 – V-BB Sprinklers & Attic Upright or Standard Spray Sprinklers Beyond an Obstruction

Figure 18 – V-BB Sprinklers & Attic Upright or Standard Spray Sprinklers at the Hip

Figure 19 – V-BB Sprinklers & Attic Upright or Standard Spray Sprinklers in a Dormer, at a Hip, or at an Eil.

Figure 20 – V-BB Sprinklers & Attic Upright or Standard Spray Sprinklers separated by compartmentalization.

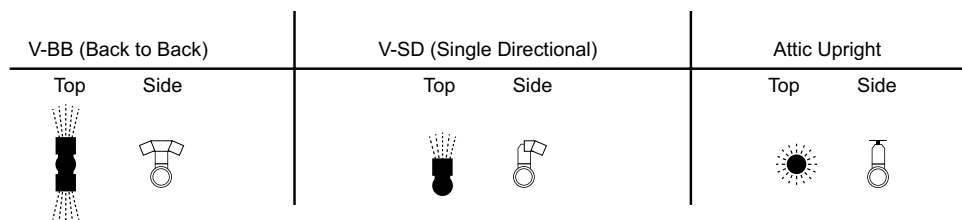
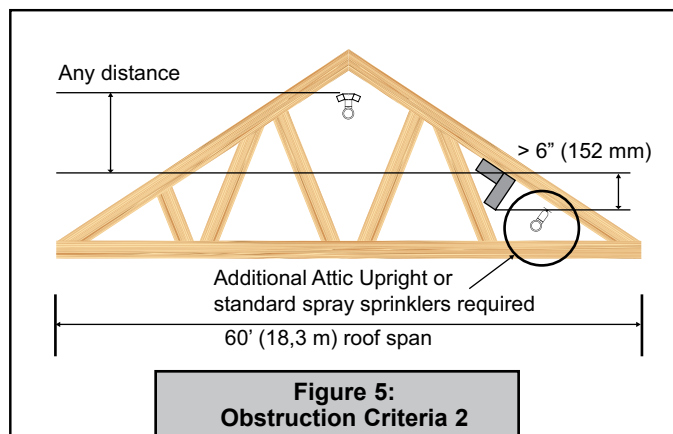
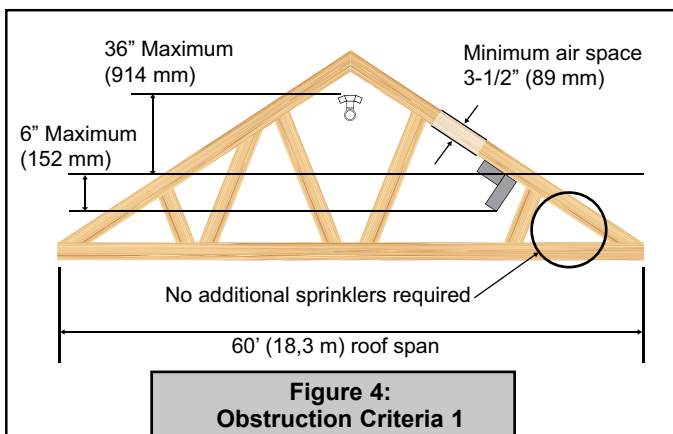

Figure 3: Sprinkler Type Legend

	<h2 style="margin: 0;">TECHNICAL DATA</h2>	<h3 style="margin: 0;">MODEL V-BB SPECIFIC APPLICATION ATTIC SPRINKLER</h3>
---	--	---

The Viking Corporation, 210 N Industrial Park Drive, Hastings MI 49058
 Telephone: 269-945-9501 Technical Services: 877-384-5464 Fax: 269-818-1680 Email: techsvcs@vikingcorp.com
 Visit the Viking website for the latest edition of this technical data page www.vikinggroupinc.com.

Refer to figures 4 and 5 below-unless otherwise noted, all Figures portray a 60' (18,3 m) roof span. Maximum 6" (152 mm) obstruction allowed provided it sits at least 36" (914 mm) vertically below the Viking V-BB Sprinkler. Larger or closer obstructions require an additional sprinkler on the opposite side of the obstruction. This criteria only limits the obstructions that run across the trusses or rafters, not the top chord of the trusses or the depth of the rafter.



Refer to Figures 6 and 7 below where the maximum spacing for Attic Upright Sprinklers is 12 ft. (3,7 m) and standard spray sprinklers is 15 ft (4,6 m). Any horizontal obstruction that is 4 ft. (1,2 m) or less in width requires minimum 6" (152 mm) clearance over the top to allow for sufficient water flow over and under. The clearance must be measured perpendicular to and from the bottom of the rafter. If the clearance is less than 6" (152 mm), an additional sprinkler is required on the opposite side of the obstruction. If the obstruction is more than 4 ft. (1,2 m) wide, an additional sprinkler is required underneath.

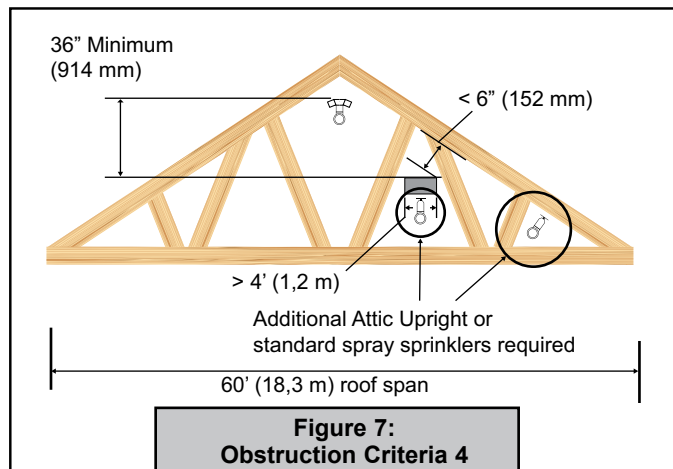
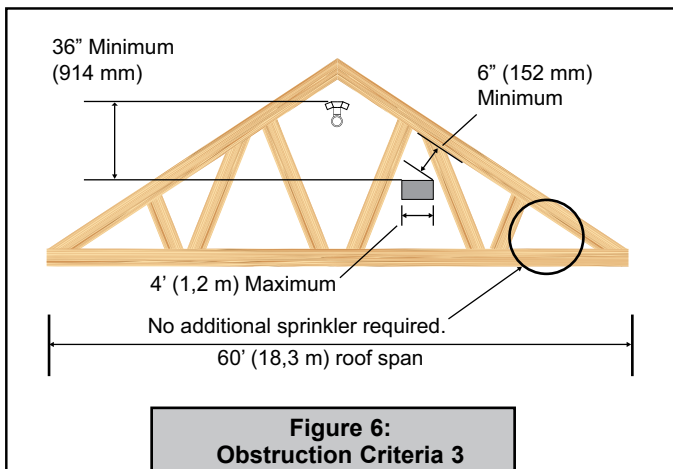

	TECHNICAL DATA	MODEL V-BB SPECIFIC APPLICATION ATTIC SPRINKLER
---	-----------------------	--

The Viking Corporation, 210 N Industrial Park Drive, Hastings MI 49058
 Telephone: 269-945-9501 Technical Services: 877-384-5464 Fax: 269-818-1680 Email: techsvcs@vikingcorp.com
 Visit the Viking website for the latest edition of this technical data page www.vikinggroupinc.com.

Refer to Figure 8 below. For vertical obstructions, the maximum dimension of the obstruction is the width and the horizontal distance is measured horizontally.

TABLE 2: OBSTRUCTION CRITERIA		
Dimension X	Distance Y	Additional Sprinklers Required Beyond Obstruction
Maximum Horizontal Dimension of Obstruction	Minimum Horizontal Distance to Obstruction	
All vertical obstructions	< 6" (152 mm)	YES
1/2" - 1" (13 mm - 25 mm)	6" (152 mm)	NO
1" - 4" (25 mm - 102 mm)	12" (305 mm)	NO
4" - 8" (101 mm - 203 mm)	24" (610 mm)	NO
8" - 10" (203 mm - 254 mm)	5'-0" (1,5 m)	NO
10" - 20" (254 mm - 508 mm)	10'-0" (3,0 m)	NO
20" - 30" (508 mm - 762mm)	15'-0" (4,6 m)	NO
30" - 40" (762 mm - 1016 mm)	20'-0" (6,1 m)	NO
40" - 48" (1016 mm - 1219 mm)	25'-0" (7,6 m)	NO
> 48" (1219 mm)	Any distance	YES

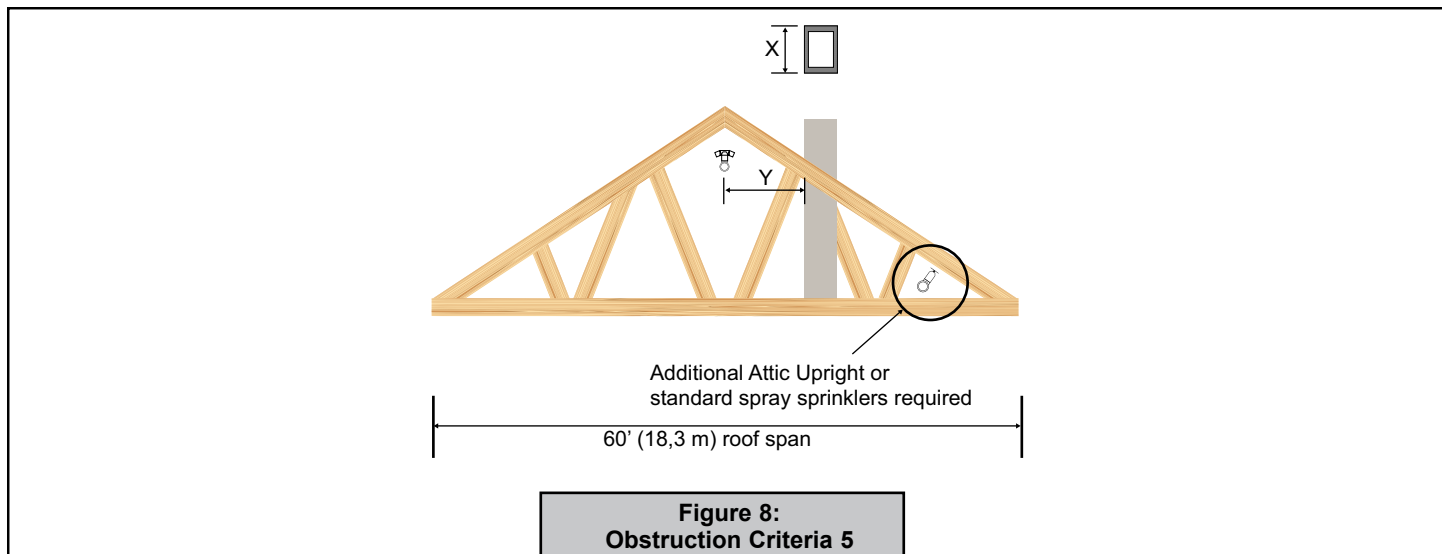

	<h2 style="margin: 0;">TECHNICAL DATA</h2>	<h3 style="margin: 0;">MODEL V-BB SPECIFIC APPLICATION ATTIC SPRINKLER</h3>
---	--	---

The Viking Corporation, 210 N Industrial Park Drive, Hastings MI 49058
Telephone: 269-945-9501 Technical Services: 877-384-5464 Fax: 269-818-1680 Email: techsvcs@vikingcorp.com
Visit the Viking website for the latest edition of this technical data page www.vikinggroupinc.com.

If a V-BB Sprinkler is 36" (914 mm) or greater above the space, and 36" (914 mm) or greater clearance above the space is present, additional sprinklers are not needed.

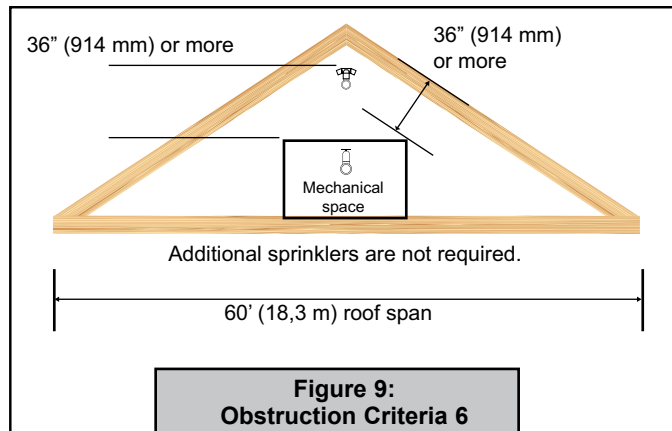

If a V-BB sprinkler is 36" (914 mm) or greater above the space, and a 12" - 36" (304 - 914 mm) clearance above the space is present, intermediate level standard sprinklers are required.

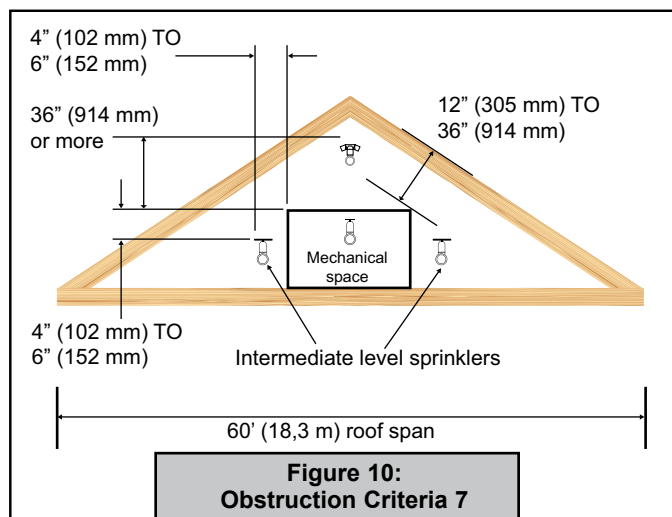

Otherwise, the area outside the mechanical space is to be protected as shown using standard spray sprinklers as necessary or by building a shear wall and installing V-SD Sprinklers.

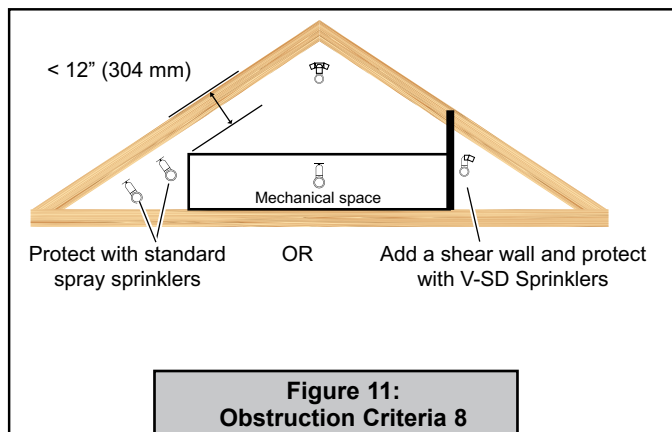



TECHNICAL DATA

**MODEL V-BB
SPECIFIC APPLICATION
ATTIC SPRINKLER**

The Viking Corporation, 210 N Industrial Park Drive, Hastings MI 49058

Telephone: 269-945-9501 Technical Services: 877-384-5464 Fax: 269-818-1680 Email: techsvcs@vikingcorp.com

Visit the Viking website for the latest edition of this technical data page www.vikinggroupinc.com.

If a V-BB Sprinkler can be installed below or between stiffeners and 16 to 22" (404 to 559 mm) distance to peak can be maintained, as well as A and B clearances to the stiffeners, no additional sprinklers are required.

A	B		
	VK681 VK684	VK682 VK685	VK683 VK686
0"	0"	0"	0"
A > 0"	A + 15"	A + 10"	A + 8"

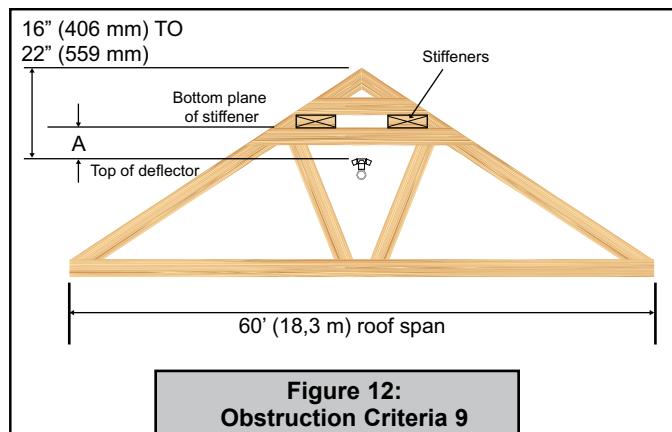
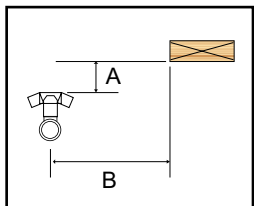

When the stiffeners are located a minimum of 12" (305 mm) below the V-BB Sprinkler, the stiffeners are 7-12" (190 mm) maximum wide, the openings are 12" (305 mm) minimum, and there is 70% minimum open area, no additional sprinklers are required.

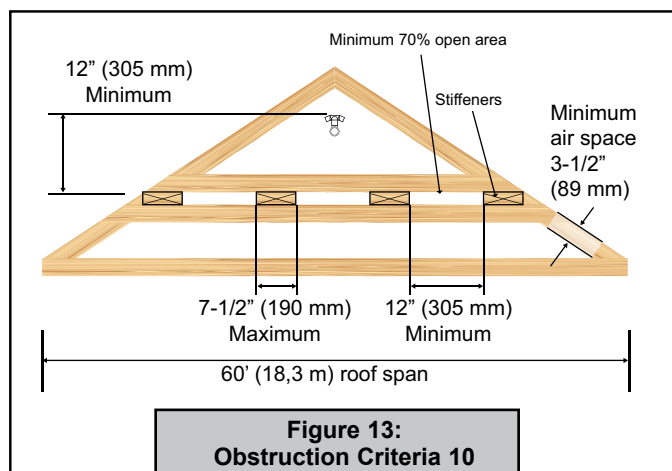

Otherwise, additional sprinklers are required as shown.

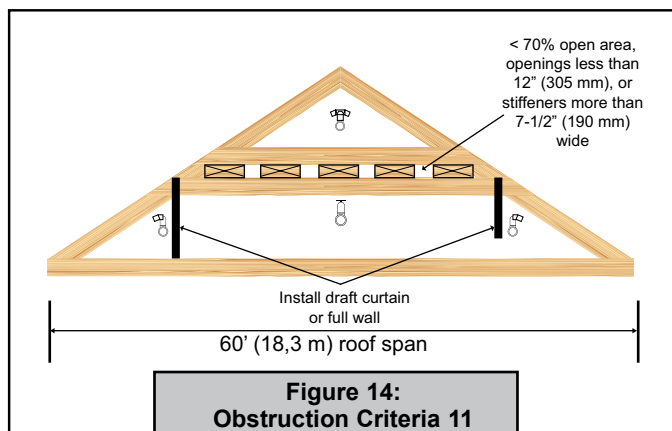



TECHNICAL DATA

**MODEL V-BB
SPECIFIC APPLICATION
ATTIC SPRINKLER**

The Viking Corporation, 210 N Industrial Park Drive, Hastings MI 49058
 Telephone: 269-945-9501 Technical Services: 877-384-5464 Fax: 269-818-1680 Email: techsvcs@vikingcorp.com
 Visit the Viking website for the latest edition of this technical data page www.vikinggroupinc.com.

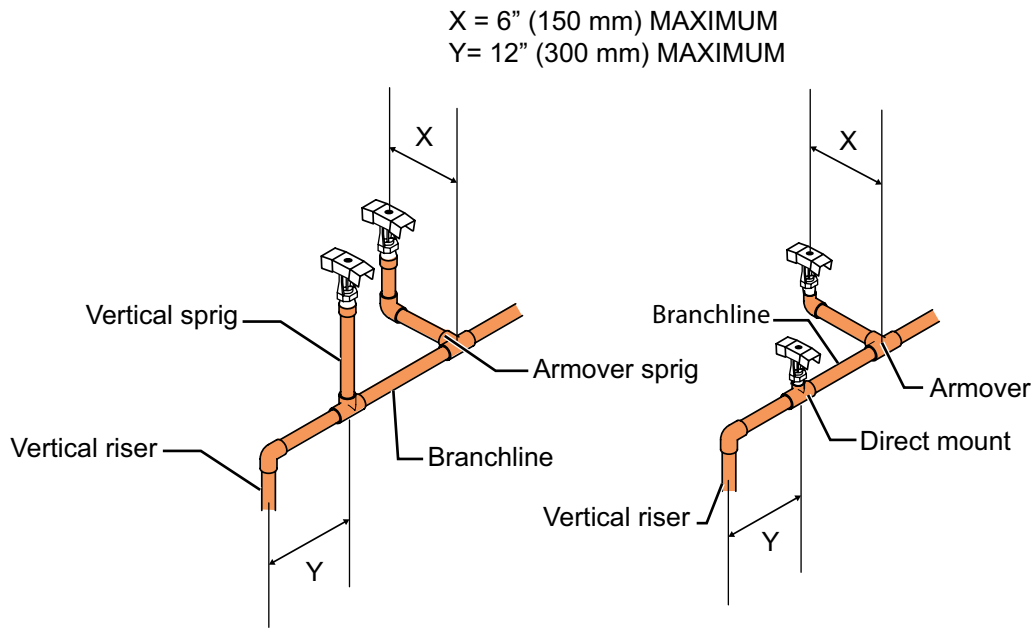

**Figure 15:
Exposed CPVC with V-BB Sprinklers**

Wet Systems: Calculate the most demanding 5 sprinklers.

Dry Systems: Calculate the most demanding 7 sprinklers.

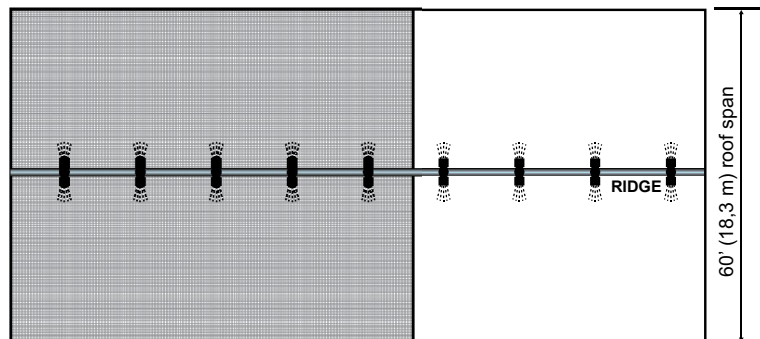

NOTE: Wet system shown.

**Figure 16:
V-BB Sprinklers**



TECHNICAL DATA

**MODEL V-BB
SPECIFIC APPLICATION
ATTIC SPRINKLER**

The Viking Corporation, 210 N Industrial Park Drive, Hastings MI 49058
 Telephone: 269-945-9501 Technical Services: 877-384-5464 Fax: 269-818-1680 Email: techsvcs@vikingcorp.com
 Visit the Viking website for the latest edition of this technical data page www.vikinggroupinc.com.

Wet Systems: Calculate the most demanding 5 V-BB sprinklers and add up to 2 of the most demanding Attic Upright or Standard Spray Sprinklers.

Dry Systems: Calculate the most demanding 7 V-BB sprinklers and add up to 2 of the most demanding Attic Upright or Standard Spray Sprinklers.

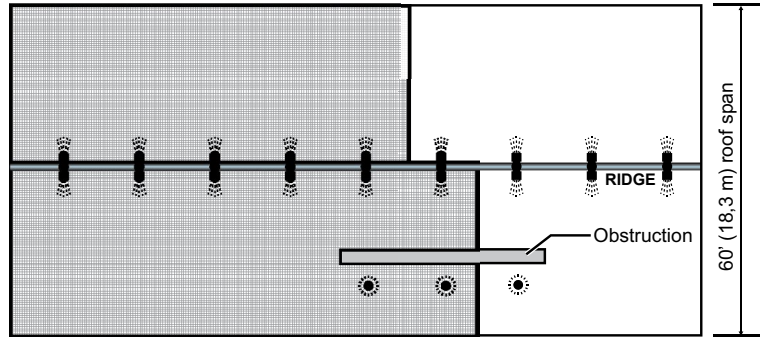

NOTE: Wet system shown.

**Figure 17:
V-BB and Attic Upright or Standard Spray Sprinklers Beyond an Obstruction**



TECHNICAL DATA

MODEL V-BB
SPECIFIC APPLICATION
ATTIC SPRINKLER

The Viking Corporation, 210 N Industrial Park Drive, Hastings MI 49058

Telephone: 269-945-9501 Technical Services: 877-384-5464 Fax: 269-818-1680 Email: techsvcs@vikingcorp.com

Visit the Viking website for the latest edition of this technical data page www.vikinggroupinc.com.

Wet Systems: Calculate the most demanding 5 V-BB sprinklers plus the 2 most demanding Attic Upright Sprinklers, and then calculate the most demanding area up to 1500 ft² (137m²) having Attic Upright sprinklers. Use the most demanding calculation.

Wet Systems: Calculate the most demanding 5 V-BB Sprinklers and add up to 2 of the most demanding Standard Spray Sprinklers, then calculate the most demanding remote design area (including ALL sprinkler types) per NFPA 13. For example, area reduction for quick response and 30% increase for sloped ceilings. Use the most demanding calculation.

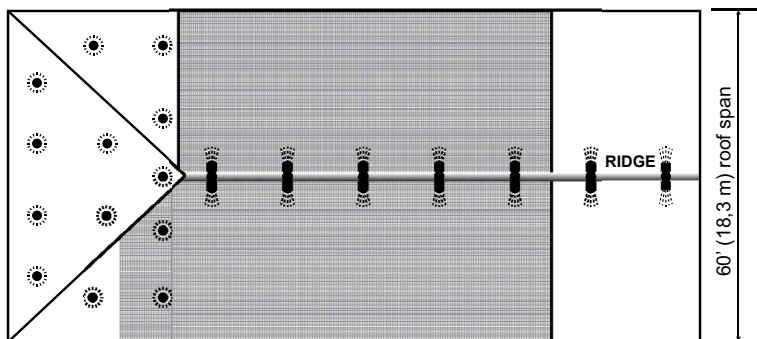

NOTE: Wet system shown.

Dry Systems: Calculate the most demanding 7 V-BB sprinklers plus the 2 most demanding Attic Upright sprinklers, and then calculate the most demanding area up to 1950 ft² (181 m²) having Attic Upright sprinklers. Use the most demanding calculation.

Dry Systems: Calculate the most demanding 7 V-BB Sprinklers and add up to 2 of the most demanding Standard Spray Sprinklers, then calculate the most demanding remote design area (including ALL sprinkler types) per NFPA 13. For example, 30% increase for sloped ceilings and 30% increase for dry systems. Use the most demanding calculation.

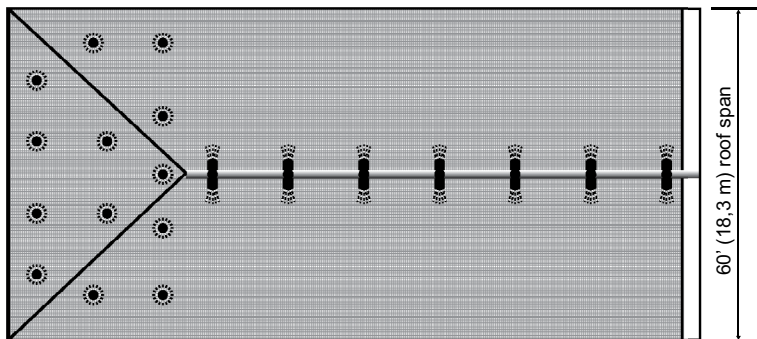

NOTE: Wet system shown.

Figure 18:
V-BB and Attic Upright or Standard Spray Sprinklers at the Hip



TECHNICAL DATA

**MODEL V-BB
SPECIFIC APPLICATION
ATTIC SPRINKLER**

The Viking Corporation, 210 N Industrial Park Drive, Hastings MI 49058

Telephone: 269-945-9501 Technical Services: 877-384-5464 Fax: 269-818-1680 Email: techsvcs@vikingcorp.com

Visit the Viking website for the latest edition of this technical data page www.vikinggroupinc.com.

Where the quantity of Attic Upright or Standard Spray sprinklers in each dormer, cross, or ell is 4 or less and all of the dormers, crosses and ells meet the maximum 4 standard sprinkler criteria, calculate the V-BB demand as shown in Figures 16 and 17, and add up to 2 of the most demanding Attic Upright or Standard Spray sprinklers in the dormer, cross, or ell that is adjacent to the Attic Upright Sprinklers that are being included in the demand calculation.

Where the quantity of Attic Upright or Standard Spray sprinklers in any dormer, cross, or ell is greater than four, refer to Figure 18.

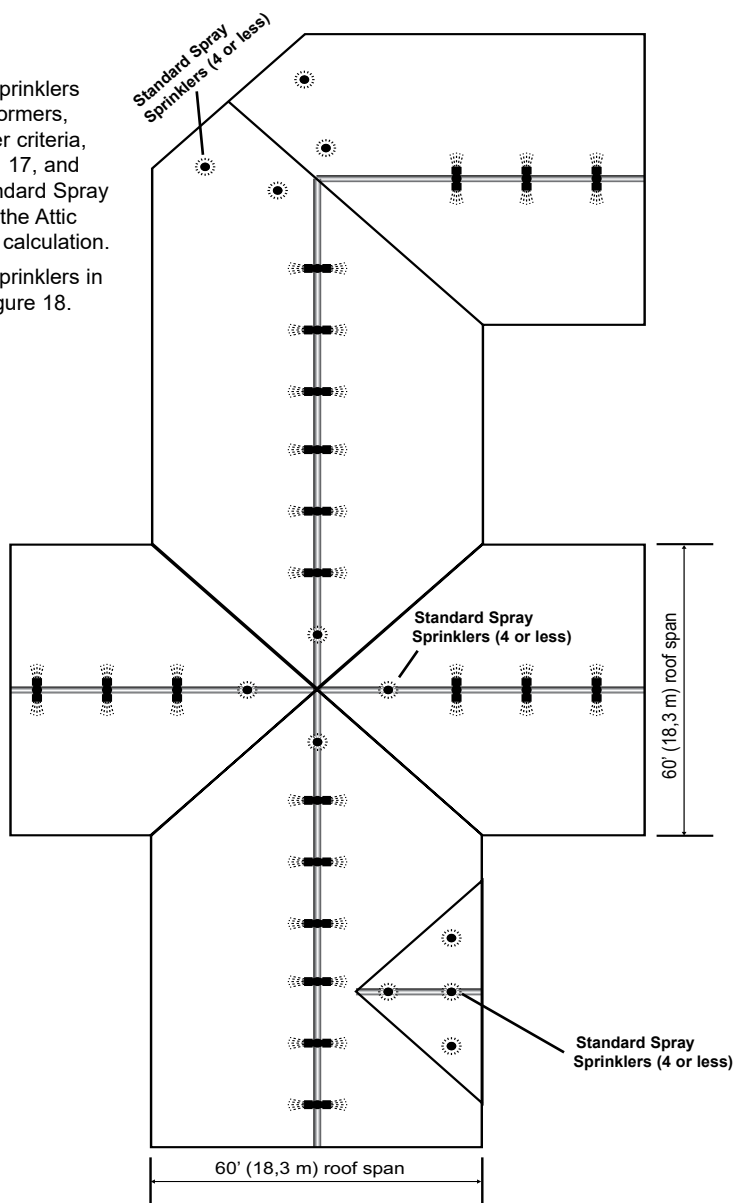

**Figure 19:
V-BB Sprinklers and Attic Upright or Standard Spray Sprinklers in a Dormer, at a Hip or at an Ell**



TECHNICAL DATA

**MODEL V-BB
SPECIFIC APPLICATION
ATTIC SPRINKLER**

The Viking Corporation, 210 N Industrial Park Drive, Hastings MI 49058

Telephone: 269-945-9501 Technical Services: 877-384-5464 Fax: 269-818-1680 Email: techsvcs@vikingcorp.com

Visit the Viking website for the latest edition of this technical data page www.vikinggroupinc.com.

Calculate the V-BB demand as described in Figures 16 and 17, then calculate the Attic Upright or Standard Spray Sprinklers per NFPA 13. use the most demanding calculation.

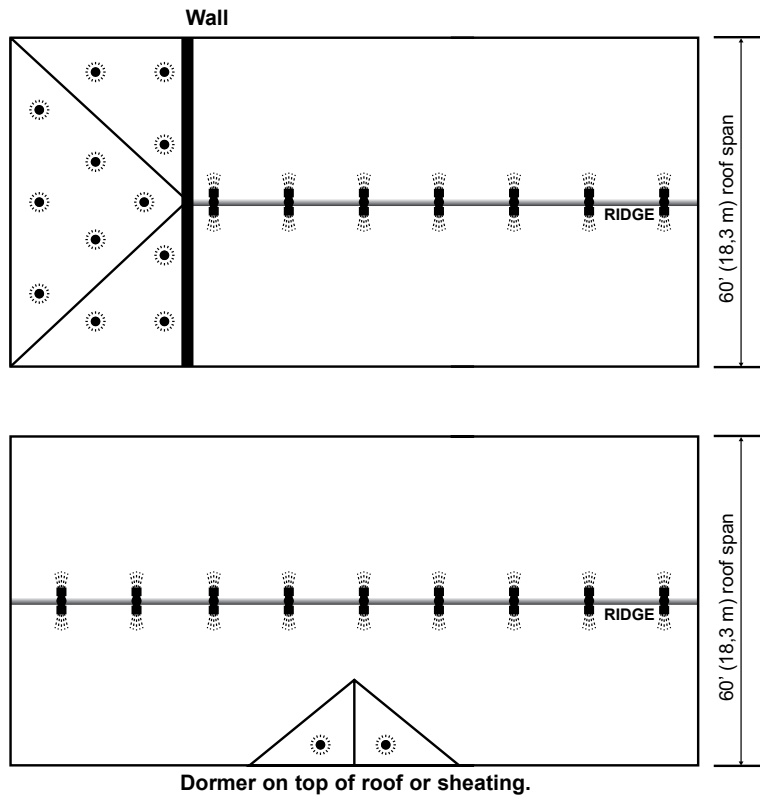

**Figure 20:
V-BB Sprinklers and Attic Upright or Standard Spray Sprinklers Separated by Compartmentalization**



BULLETIN

CARE AND HANDLING OF SPRINKLERS

The Viking Corporation, 210 N Industrial Park Drive, Hastings MI 49058
 Telephone: 269-945-9501 Technical Services: 877-384-5464 Fax: 269-818-1680 Email: techsvcs@vikingcorp.com

SPRINKLERS ARE FRAGILE - HANDLE WITH CARE!

General Handling and Storage:

- Store sprinklers in a cool, dry place.
- Protect sprinklers during storage, transport, handling, and after installation.
- Use the original shipping containers. DO NOT place sprinklers loose in boxes, bins, or buckets.
- Keep sprinklers separated at all times. DO NOT allow metal parts to contact sprinkler operating elements.

For Pre-Assembled Drops:

- Protect sprinklers during handling and after installation.
- For recessed assemblies, use the protective sprinkler cap (Viking Part Number 10364).

Sprinklers with Protective Shields or Caps:

- DO NOT remove shields or caps until after sprinkler installation and there no longer is potential for mechanical damage to the sprinkler operating elements.
- **Sprinkler shields or caps MUST be removed BEFORE placing the system in service!**
- Remove the sprinkler shield by carefully pulling it apart where it is snapped together.
- Remove the cap by turning it slightly and pulling it off the sprinkler.

Sprinkler Installation:

- DO NOT use the sprinkler deflector or operating element to start or thread the sprinkler into a fitting.
- **Use only the designated sprinkler head wrench!** Refer to the current sprinkler technical data page to determine the correct wrench for the model of sprinkler used.
- DO NOT install sprinklers onto piping at the floor level.
- Install sprinklers after the piping is in place to prevent mechanical damage.
- DO NOT allow impacts such as hammer blows directly to sprinklers or to fittings, pipe, or couplings in close proximity to sprinklers. Sprinklers can be damaged from direct or indirect impacts.
- DO NOT attempt to remove drywall, paint, etc., from sprinklers.
- **Take care not to over-tighten the sprinkler and/or damage its operating parts!**

Maximum Torque:

- 1/2" NPT: 14 ft-lbs. (19.0 N-m)**
- 3/4" NPT: 20 ft-lbs. (27.1 N-m)**
- 1" NPT: 30 ft-lbs. (40.7 N-m)**



CORRECT
(Original container used)

INCORRECT
(Placed loose in box)

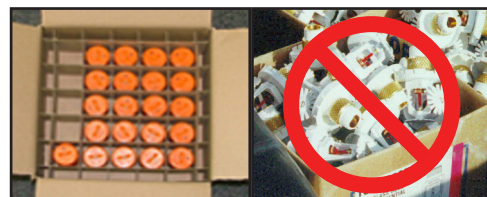

CORRECT
(Protected with caps)

INCORRECT
(Protective caps not used)



CORRECT
(Piping is in place at the ceiling)

INCORRECT
(Sprinkler at floor level)



CORRECT
(Special installation wrenches)

INCORRECT
(Designated wrench not used)

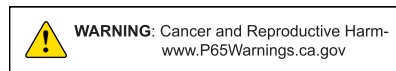

! WARNING

Any sprinkler with a loss of liquid from the glass bulb or damage to the fusible element should be destroyed. Never install sprinklers that have been dropped, damaged, or exposed to temperatures exceeding the maximum ambient temperature allowed. Sprinklers that have been painted in the field must be replaced per NFPA 13. Protect sprinklers from paint and paint overspray in accordance with the installation standards. Do not clean sprinklers with soap and water, ammonia, or any other cleaning fluid. Do not use adhesives or solvents on sprinklers or their operating elements.

Refer to the appropriate technical data page and NFPA standards for complete care, handling, installation, and maintenance instructions. For additional product and system information Viking data pages and installation instructions are available on the Viking Web site at www.vikinggroupinc.com.



BULLETIN

CARE AND HANDLING
OF SPRINKLERS

The Viking Corporation, 210 N Industrial Park Drive, Hastings MI 49058
 Telephone: 269-945-9501 Technical Services: 877-384-5464 Fax: 269-818-1680 Email: techsvcs@vikingcorp.com

PROTECTIVE SPRINKLER SHIELDS AND CAPS

General Handling and Storage:

Many Viking sprinklers are available with a plastic protective cap or shield temporarily covering the operating elements. The snap-on shields and caps are factory installed and are intended to help protect the operating elements from mechanical damage during shipping, storage, and installation. NOTE: It is still necessary to follow the care and handling instructions on the appropriate sprinkler technical data sheets* when installing sprinklers with bulb shields or caps.

WHEN TO REMOVE THE SHIELDS AND CAPS:

NOTE: SHIELDS AND CAPS MUST BE REMOVED FROM SPRINKLERS BEFORE PLACING THE SYSTEM IN SERVICE!

Remove the shield or cap from the sprinkler only after checking all of the following:

- The sprinkler has been installed*.
- The wall or ceiling finish work is completed where the sprinkler is installed and there no longer is a potential for mechanical damage to the sprinkler operating elements.

SHIELDS AND CAPS MUST BE REMOVED FROM SPRINKLERS BEFORE PLACING THE SYSTEM IN SERVICE!

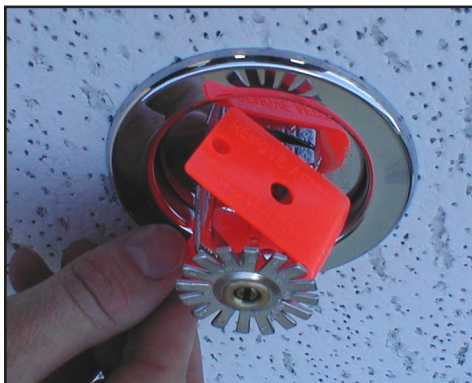

Figure 1: Sprinkler shield being removed from a pendent sprinkler.



Figure 2: Sprinkler cap being removed from a pendent sprinkler.



Figure 3: Sprinkler cap being removed from an upright sprinkler.

HOW TO REMOVE SHIELDS AND CAPS:

No tools are necessary to remove the shields or caps from sprinklers. DO NOT use any sharp objects to remove them! **Take care not to cause mechanical damage to sprinklers when removing the shields or caps.** When removing caps from fusible element sprinklers, use care to prevent dislodging ejector springs or damaging fusible elements. NOTE: Squeezing the sprinkler cap excessively could damage sprinkler fusible elements.

- To remove the shield, simply pull the ends of the shield apart where it is snapped together. Refer to Figure 1.
- To remove the cap, turn it slightly and pull it off the sprinkler. Refer to Figures 2 and 3.

NOTICE

Refer to the current sprinkler technical data page to determine the correct sprinkler wrench for the model of sprinkler used.

WARNING

Never install sprinklers that have been dropped, damaged, or exposed to temperatures in excess of the maximum ambient temperature allowed.

* Refer to the appropriate current technical data pages for complete care, handling, and installation instructions. Data pages are included with each shipment from Viking or Viking distributors. They can also be found on the Web site at www.vikinggroupinc.com.



BULLETIN

CARE AND HANDLING
OF SPRINKLERS

The Viking Corporation, 210 N Industrial Park Drive, Hastings MI 49058
 Telephone: 269-945-9501 Technical Services: 877-384-5464 Fax: 269-818-1680 Email: techsvcs@vikingcorp.com



CONCEALED COVER ASSEMBLIES ARE FRAGILE!
TO ASSURE SATISFACTORY PERFORMANCE OF THE PRODUCT, HANDLE WITH CARE.

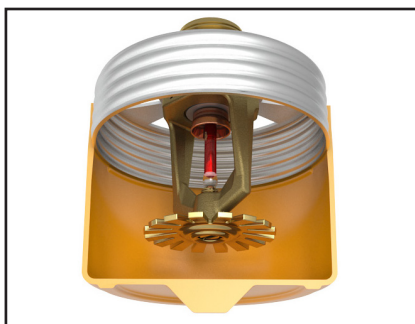

Concealed Sprinkler and Adapter
 Assembly with Protective Cap

Concealed Sprinkler and Adapter
 Assembly (Protective Cap Removed)



Cover Plate Assembly
 (Pendent Cover 12381 shown)



GENERAL HANDLING AND STORAGE INSTRUCTIONS:

- Do not store in temperatures exceeding 100 °F (38 °C). Avoid direct sunlight and confined areas subject to heat.
- Protect sprinklers and cover assemblies during storage, transport, handling, and after installation.
 - Use original shipping containers.
 - Do not place sprinklers or cover assemblies loose in boxes, bins, or buckets.
- Keep the sprinkler bodies covered with the protective sprinkler cap any time the sprinklers are shipped or handled, during testing of the system, and while ceiling finish work is being completed.
- Use only the designated Viking recessed sprinkler wrench (refer to the appropriate sprinkler data page) to install these sprinklers. **NOTE:** The protective cap is temporarily removed during installation and then placed back on the sprinkler for protection until finish work is completed.
- Do not over-tighten the sprinklers into fittings during installation.
- Do not use the sprinkler deflector to start or thread the sprinklers into fittings during installation.
- Do not attempt to remove drywall, paint, etc., from the sprinklers.
- Remove the plastic protective cap from the sprinkler before attaching the cover plate assembly. **PROTECTIVE CAPS MUST BE REMOVED FROM SPRINKLERS BEFORE PLACING THE SYSTEM IN SERVICE!**

Refer to the appropriate current technical data pages for complete care, handling, and installation instructions. Data pages are included with each shipment from Viking or Viking distributors. They can also be found on the Web site at www.vikinggroupinc.com.



BULLETIN

CARE AND HANDLING
OF SPRINKLERS

The Viking Corporation, 210 N Industrial Park Drive, Hastings MI 49058

Telephone: 269-945-9501 Technical Services: 877-384-5464 Fax: 269-818-1680 Email: techsvcs@vikingcorp.com

USE THE FOLLOWING PRECAUTIONS WHEN HANDLING WAX-COATED SPRINKLERS

Many of Viking's sprinklers are available with factory-applied wax coating for corrosion resistance. These sprinklers MUST receive appropriate care and handling to avoid damaging the wax coating and to assure satisfactory performance of the product.

General Handling and Storage of Wax-Coated Sprinklers:

- Store the sprinklers in a cool, dry place (in temperatures below the maximum ambient temperature allowed for the sprinkler temperature rating. Refer to Table 1 below.)
- Store containers of wax-coated sprinklers separate from other sprinklers.
- Protect the sprinklers during storage, transport, handling, and after installation.
- Use original shipping containers.
- Do not place sprinklers in loose boxes, bins, or buckets.

Installation of Wax-Coated Sprinklers:

Use only the special sprinkler head wrench designed for installing wax-coated Viking sprinklers (any other wrench may damage the unit).

- Take care not to crack the wax coating on the units.
- For touching up the wax coating after installation, wax is available from Viking in bar form. Refer to Table 1 below. The coating MUST be repaired after sprinkler installation to protect the corrosion-resistant properties of the sprinkler.
- Use care when locating sprinklers near fixtures that can generate heat. Do not install sprinklers where they would be exposed to temperatures exceeding the maximum recommended ambient temperature for the temperature rating used.
- Inspect the coated sprinklers frequently soon after installation to verify the integrity of the corrosion resistant coating. Thereafter, inspect representative samples of the coated sprinklers in accordance with NFPA 25. Close up visual inspections are necessary to determine whether the sprinklers are being affected by corrosive conditions.

TABLE 1

Sprinkler Temperature Rating (Fusing Point)	Wax Part Number	Wax Melting Point	Maximum Ambient Ceiling Temperature ¹	Wax Color
155 °F (68 °C) / 165 °F (74 °C)	02568A	148 °F (64 °C)	100 °F (38 °C)	Light Brown
175 °F (79 °C)	04146A	161 °F (71 °C)	150 °F (65 °C)	Brown
200 °F (93 °C)	04146A	161 °F (71 °C)	150 °F (65 °C)	Brown
220 °F (104 °C)	02569A	170 °F (76 °C)	150 °F (65 °C)	Dark Brown
286 °F (141 °C)	02569A	170 °F (76 °C)	150 °F (65 °C)	Dark Brown

¹ Based on NFPA-13. Other limits may apply, depending on fire loading, sprinkler location, and other requirements of the Authority Having Jurisdiction. Refer to specific installation standards.



Never install sprinklers that have been dropped, damaged, or exposed to temperatures in excess of the maximum ambient temperature allowed.

Refer to the appropriate current technical data pages for complete care, handling, and installation instructions. Data pages are included with each shipment from Viking or Viking distributors. They can also be found on the Web site at www.vikinggroupinc.com.



TECHNICAL DATA

SPRINKLER OVERVIEW

The Viking Corporation, 210 N Industrial Park Drive, Hastings MI 49058

Telephone: 269-945-9501 Technical Services: 877-384-5464 Fax: 269-818-1680 Email: techsvcs@vikingcorp.com

1. DESCRIPTION

Viking fire sprinklers consist of a threaded frame with a specific waterway or orifice size and a deflector for distributing water in a specified pattern. A closed or sealed sprinkler refers to a complete assembly, including the thermosensitive operating element. An open sprinkler does not use an operating element and is open at all times. The distribution of water is intended to extinguish a fire or to control its spread.

Viking sprinklers are available in several models and styles. Refer to specific sprinkler technical data pages for available styles, finishes, temperature ratings, thread sizes, and nominal K-Factors for the particular model selected.

2. LISTINGS AND APPROVALS

Refer to the Approval Charts on the appropriate sprinkler technical data page(s) and/or approval agency listings.



WARNING: Cancer and Reproductive Harm-
www.P65Warnings.ca.gov

3. TECHNICAL DATA

Pressure Ratings:

Maximum allowable water working pressure is 175 psig (12 Bar) unless rated and specified for high water working pressure [250 psig (17.2 bar)].

Sprinkler Identification:

Viking sprinklers are identified and marked with the word "Viking", the sprinkler identification number (SIN) consisting of "VK" plus a three digit number*, the model letter, and the year of manufacture.

Available Finishes:

Viking sprinklers are available in several decorative finishes. Some models are available with corrosion-resistant coatings or are fabricated from non-corrosive material. Refer to the sprinkler technical data page for additional information.

Available Temperature Ratings:

Viking sprinklers are available in several temperature ratings that relate to a specific temperature classification. Applicable installation rules mandate the use and limitations of each temperature classification. In selecting the appropriate temperature classification, the maximum expected ceiling temperature must be known. When there is doubt as to the maximum temperature at the sprinkler location, a maximum-reading thermometer should be used to determine the temperature under conditions that would show the highest readings to be expected. In addition, recognized installation rules may require a higher temperature classification, depending upon sprinkler location, occupancy classification, commodity classification, storage height, and other hazards. In all cases, the maximum expected ceiling temperature dictates the lowest allowable temperature classification. Sprinklers located immediately adjacent to a heat source may require a higher temperature rating.

K-Factors:

Viking sprinklers are available in several orifice sizes with related K-Factors. The orifice is a tapered waterway and, therefore, the K-Factor given is nominal. Nominal U.S. K-Factors are provided in accordance with the 1999 edition of NFPA 13, Section 3-2.3. Refer to the specific data page for appropriate K-Factor information.

Available Styles:

Viking sprinklers are available for installation in several positions as indicated by a stamping on the deflector. The deflector style dictates the appropriate installation position of the sprinkler; it breaks the solid stream of water issuing from the sprinkler orifice to form a specific spray pattern. The following list indicates the various styles and identification of Viking sprinklers.

UPRIGHT SPRINKLER: A sprinkler intended to be installed with the deflector above the frame so water flows upward through the orifice, striking the deflector and forming an umbrella-shaped spray pattern downward. Marked "SSU" (Standard Sprinkler Upright) or "UPRIGHT" on the deflector.

PENDENT SPRINKLER: A sprinkler intended to be oriented with the deflector below the frame so water flows downward through the orifice, striking the deflector and forming an umbrella-shaped spray pattern downward. Marked "SSP" (Standard Sprinkler Pendent) or "PENDENT" on the deflector.

CONVENTIONAL SPRINKLER: An "old style" sprinkler intended to be installed with the deflector in either the upright or pendent position. The deflector provides a spherical type pattern with 40 to 60 percent of the water initially directed downward and a proportion directed upward. Must be installed in accordance with installation rules for conventional or old style sprinklers. **DO NOT USE AS A REPLACEMENT FOR STANDARD SPRAY SPRINKLERS.** Marked "C U/P" (Conventional Upright/Pendent) on the deflector.

Viking Technical Data may be found on
The Viking Corporation's Web site at
<http://www.vikinggroupinc.com>.
The Web site may include a more recent
edition of this Technical Data Page.



TECHNICAL DATA

SPRINKLER OVERVIEW

The Viking Corporation, 210 N Industrial Park Drive, Hastings MI 49058

Telephone: 269-945-9501 Technical Services: 877-384-5464 Fax: 269-818-1680 Email: techsvcs@vikingcorp.com

VERTICAL SIDEWALL (VSW) SPRINKLER: A sprinkler intended for installation near the wall and ceiling. The deflector provides a water spray pattern outward in a quarter-spherical pattern and can be installed in the upright or pendent position with the flow arrow in the direction of discharge. Marked "SIDEWALL" on the deflector with an arrow and the word "FLOW". (Note: Some vertical sidewall sprinklers can only be installed in the upright or pendent position—in this case, the sprinkler will also be marked "UPRIGHT" or "PENDENT".)

HORIZONTAL SIDEWALL (HSW) SPRINKLER: A sprinkler intended for installation near the wall and ceiling. The special deflector provides a water spray pattern outward in a quarter-spherical pattern. Most of the water is directed away from the nearby wall with a small portion directed at the wall behind the sprinkler. The top of the deflector is oriented parallel with the ceiling or roof. The flow arrows point in the direction of discharge. Marked "SIDEWALL" and "TOP" with an arrow and the word "FLOW".

EXTENDED COVERAGE (EC) SPRINKLER: A spray sprinkler designed to discharge water over an area having the maximum dimensions indicated in the individual listings. Maximum area of coverage, minimum flow rate, orifice size, and nominal K-Factor are specified in the individual listings. EC sprinklers are intended for Light-Hazard occupancies with smooth, flat, horizontal ceilings unless otherwise specified. In addition to the above markings, the sprinkler is marked "EC".

QUICK RESPONSE (QR) SPRINKLER: A spray sprinkler with a fast-actuating operating element. The use of quick response sprinklers may be limited due to occupancy and hazard. Refer to the Authority Having Jurisdiction (AHJ) prior to installing.

QUICK RESPONSE EXTENDED COVERAGE (QREC) SPRINKLER: A spray sprinkler designed to discharge water over an area having the maximum dimensions indicated in the individual listing. This is a sprinkler with an operating element that meets the criteria for quick response. QREC sprinklers are only intended for Light Hazard occupancies. The sprinkler is marked "QREC".

FLUSH SPRINKLER: A decorative spray sprinkler intended for installation with a concealed piping system. The unit is mounted flush with the ceiling or wall, with the fusible link exposed. Upon actuation, the deflector extends beyond the ceiling or wall to distribute water discharge. The sprinkler is marked "SSP", "PEND", or "SIDEWALL" and "TOP".

CONCEALED SPRINKLER: A decorative spray sprinkler intended for installation with a concealed piping system. The sprinkler is hidden from view by a cover plate installed flush with the ceiling or wall. During fire conditions, the cover plate detaches, and upon sprinkler actuation, the deflector extends beyond the ceiling or wall to distribute water discharge. The sprinkler is marked "SSP", "PEND", or "SIDEWALL" and "TOP".

RECESSED SPRINKLER: A spray sprinkler assembly intended for installation with a concealed piping system. The assembly consists of a sprinkler installed in a decorative adjustable recessed escutcheon that minimizes the protrusion of the sprinkler beyond the ceiling or wall without adversely affecting the sprinkler distribution or sensitivity. Refer to the appropriate technical data page for allowable sprinkler models, temperature ratings, and occupancy classifications. DO NOT RECESS ANY SPRINKLER NOT LISTED FOR USE WITH THE ESCUTCHEON.

CORROSION-RESISTANT SPRINKLER: A special service sprinkler with non-corrosive protective coatings, or that is fabricated from non-corrosive material, for use in atmospheres that would normally corrode sprinklers.

DRY SPRINKLER: A special-service sprinkler intended for installation on dry pipe systems or wet pipe systems where the sprinkler is subject to freezing temperatures. The unit consists of a sprinkler permanently secured to an extension nipple with a sealed inlet end to prevent water from entering the nipple until the sprinkler operates. The unit MUST be installed in a tee fitting. Dry upright sprinklers are marked with the "B" dimension [distance from the face of the fitting (tee) to the top of the deflector]. Dry pendent and sidewall sprinklers are marked with the "A" dimension [the distance from the face of fitting (tee) to the finished surface of the ceiling or wall].

LARGE DROP SPRINKLER: A type of special application sprinkler used to provide fire control of specific high-challenge fire hazards. Large drop sprinklers are designed to produce an umbrella-shaped spray pattern downward with a higher percentage of "large" water droplets than standard spray sprinklers. The sprinkler has an extra-large orifice with a nominal K-Factor of 11.2. Marked "HIGH CHALLENGE" and "UPRIGHT".

EARLY SUPPRESSION FAST-RESPONSE (ESFR) SPRINKLER: A sprinkler intended to provide fire suppression of specific high-challenge fire hazards through the use of a fast response fusible link, 14.0, 16.8, or 25.2 nominal K-Factor, and special deflector. ESFR sprinklers are designed to produce high-momentum water droplets in a hemispherical pattern below the deflector. This permits penetration of the fire plume and direct wetting of the burning fuel surface while cooling the atmosphere early in the development of a high-challenge fire. Marked "ESFR" and "UPRIGHT" or "PEND".

INTERMEDIATE LEVEL/RACK STORAGE SPRINKLER: A standard spray sprinkler assembly designed to protect its operating element from the spray of sprinklers installed at higher elevations. The assembly consists of a standard or large orifice upright or pendent sprinkler with an integral upright or pendent water shield and guard assembly. Use only those sprinklers that have been tested and listed for use with the assembly. Refer to the technical data page for allowable sprinkler models.

RESIDENTIAL SPRINKLER: A sprinkler intended for use in the following occupancies: one- and two-family dwellings with the fire protection sprinkler system installed in accordance with NFPA 13D; residential occupancies up to four stories in height with the fire protection system installed in accordance with NFPA 13R; and where allowed by the Authority Having Jurisdiction in residential portions of any occupancy with the fire protection system installed in accordance with NFPA 13.



TECHNICAL DATA

SPRINKLER OVERVIEW

The Viking Corporation, 210 N Industrial Park Drive, Hastings MI 49058

Telephone: 269-945-9501 Technical Services: 877-384-5464 Fax: 269-818-1680 Email: techsvcs@vikingcorp.com

Residential sprinklers have a unique distribution pattern and utilize a “fast response” heat sensitive operating element. They enhance survivability in the room of fire origin and are designed to provide a life safety environment for a minimum of ten minutes. For this reason, residential sprinklers must not be used to replace standard sprinklers unless tested for and approved by the Authority Having Jurisdiction. In addition to standard markings, the unit is identified as “RESIDENTIAL SPRINKLER” or “RES”.

4. INSTALLATION

Refer to appropriate NFPA Installation Standards.

5. OPERATION

Refer to the appropriate sprinkler technical data page(s).

6. INSPECTIONS, TESTS AND MAINTENANCE

Refer to NFPA 25 for Inspection, Testing and Maintenance requirements.

7. AVAILABILITY

Viking sprinklers are available through a network of domestic and international distributors. See The Viking Corporation web site for the closest distributor or contact The Viking Corporation.

8. GUARANTEE

For details of warranty, refer to Viking’s current list price schedule or contact Viking directly.

IMPORTANT: Always refer to Bulletin Form No. F_091699 - Care and Handling of Sprinklers and the appropriate sprinkler general care, installation, and maintenance guide. Vikings sprinklers are to be installed in accordance with the latest edition of Viking technical data, the appropriate standards of NFPA, FM Global, LPCB, APSAD, VdS or other similar organizations, and also with the provisions of governmental codes, ordinances, and standards, whenever applicable. The sprinkler technical data page may contain installation requirements specific for the sprinkler model selected. The use of certain types of sprinklers may be limited due to occupancy and hazard. Refer to the Authority Having Jurisdiction prior to installation.



TECHNICAL DATA

SPRINKLER GENERAL CARE, INSTALLATION, AND MAINTENANCE GUIDE

The Viking Corporation, 210 N Industrial Park Drive, Hastings MI 49058

Telephone: 269-945-9501 Technical Services: 877-384-5464 Fax: 269-818-1680 Email: techsvcs@vikingcorp.com

Visit the Viking website for the latest edition of this technical data page.

1. DESCRIPTION - STANDARD RESPONSE, QUICK RESPONSE, EXTENDED COVERAGE, AND DRY SPRINKLERS

Viking thermosensitive spray sprinklers consist of a small frame and either a glass bulb or a fusible operating element. Available styles include pendent, flush pendent, concealed pendent, upright, horizontal sidewall, vertical sidewall, or conventional, depending on the particular sprinkler model selected.

Viking sprinklers are available with various finishes, temperature ratings, responses, and K-Factors to meet design requirements†. Used in conjunction with one of the corrosion-resistant coatings (for frame style sprinklers), the units provide protection against many corrosive environments. In addition, the special Polyester or Teflon® coatings can be used in decorative applications where colors are desired.

† Refer to the sprinkler technical data page for available styles, finishes, temperature ratings, responses, and nominal K-Factors for specific sprinkler models.

2. LISTINGS AND APPROVALS

Refer to the Approval Charts on the appropriate sprinkler technical data page(s) and/or approval agency listings.

3. TECHNICAL DATA

Specifications:

Refer to the appropriate sprinkler technical data sheet.

Material Standards:

Refer to the appropriate sprinkler technical data sheet.

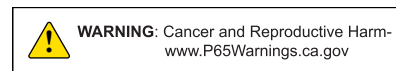

4. INSTALLATION

NOTE: Take care not to over-tighten the sprinkler and/or damage its operating parts!

Maximum Torque:

1/2" NPT: 14 ft-lbs. (19.0 N-m)

3/4" NPT: 20 ft-lbs. (27.1 N-m)

1" NPT: 30 ft-lbs. (40.7 N-m)

A. Care and Handling (also refer to Bulletin - Care and Handling of Sprinklers, Form No. F_091699.)

Sprinklers must be handled with care. They must be stored in a cool, dry place in their original shipping container. Never install sprinklers that have been dropped, damaged, or exposed to temperatures exceeding the maximum ambient temperature allowed (refer to the temperature chart on the sprinkler technical data page). Never install any glass-bulb sprinkler if the bulb is cracked or if there is a loss of liquid from the bulb. A small air bubble should be present in the glass bulb. Any sprinkler with a loss of liquid from the glass bulb or damage to the fusible element should be destroyed immediately. (Note: Installing glass bulb sprinklers in direct sunlight (ultraviolet light) may affect the color of the dye used to color code the bulb. This color change does not affect the integrity of the bulb.)

Sprinklers must be protected from mechanical damage during storage, transport, handling, and after installation. Sprinklers subject to mechanical damage must be protected with an approved sprinkler guard.

Use only sprinklers listed as corrosion resistant when subject to corrosive environments. When installing corrosion-resistant sprinklers, take care not to damage the corrosion-resistant coating. Use only the special wrench designed for installing coated or recessed Viking sprinklers (any other wrench may damage the unit).

Concealed sprinklers must be installed in neutral or negative pressure plenums only!

Use care when locating sprinklers near fixtures that can generate heat. Do not install sprinklers where they could be exposed to temperatures exceeding the maximum recommended ambient temperature for the temperature rating used.

Wet pipe systems must be provided with adequate heat. Sprinklers supplied from dry systems in areas subject to freezing must be listed dry sprinklers, upright, or horizontal sidewall sprinklers installed so that water is not trapped. For dry systems, pendent sprinklers and sidewall sprinklers installed on return bends are permitted, where the sprinklers, return bend, and branch line piping are in an area maintained at or above 40 °F (4 °C).

B. Installation Instructions - Standard Spray Sprinklers

Viking sprinklers are manufactured and tested to meet the rigid requirements of approving agencies. They are designed to be installed in accordance with recognized installation standards. Deviation from the standards or any alteration to sprinklers or cover plate assemblies after they leave the factory including, but not limited to: painting, plating, coating, or modification, may render them inoperative and will automatically nullify the approvals and any guarantee made by The Viking Corporation.



TECHNICAL DATA

SPRINKLER GENERAL CARE, INSTALLATION, AND MAINTENANCE GUIDE

The Viking Corporation, 210 N Industrial Park Drive, Hastings MI 49058

Telephone: 269-945-9501 Technical Services: 877-384-5464 Fax: 269-818-1680 Email: techsvcs@vikingcorp.com

Visit the Viking website for the latest edition of this technical data page.

Before installation, be sure to have the appropriate sprinkler model and style, with the correct K-Factor, temperature rating, and response characteristics. Sprinklers must be installed after the piping is in place to prevent mechanical damage. Keep sprinklers with protective caps or bulb shields contained within the caps or shields during installation and testing, and any time the sprinkler is shipped or handled.

1a. For frame-style sprinklers, install escutcheon (if used), which is designed to thread onto the external threads of the sprinkler. Refer to the appropriate sprinkler data page to determine approved escutcheons for use with specific sprinkler models.

1b. For flush and concealed style sprinklers: Cut the sprinkler nipple so that the 1/2" or 3/4" (15 mm or 20 mm)* NPT outlet of the reducing coupling is at the desired location, and centered in the opening* in the ceiling or wall.

*Size depends on the sprinkler model used. Refer to the sprinkler technical data page.

2. Apply a small amount of pipe-joint compound or tape to the external threads of the sprinkler only, taking care not to allow a build-up of compound in the sprinkler inlet. **NOTE:** Sprinklers with protective caps or bulb shields must have the caps or shields kept on them when applying pipe-joint compound or tape. *Exception: For domed concealed sprinklers, remove the protective cap for installation, and then place it back on the sprinkler temporarily.*

3. Refer to the appropriate sprinkler technical data page to determine the correct sprinkler wrench for the model of sprinkler used. DO NOT use the deflector or fusible element to start or thread the sprinkler into a fitting.

a. Install the sprinkler onto the piping using the special sprinkler wrench only, taking care not to over-tighten or damage the sprinkler.

b. For flush and concealed style sprinklers: the internal diameter of the special sprinkler installation wrench is designed for use with the sprinkler contained in the protective cap. *Exception: For domed concealed sprinklers, remove the protective cap for installation, and then place it back on the sprinkler temporarily.* Thread the flush or concealed sprinkler into the 1/2" or 3/4" (15 mm or 20 mm)* NPT outlet of the coupling by turning it clockwise with the special sprinkler wrench. *Thread size depends on the particular sprinkler model used. Refer to the sprinkler technical data page.

C. Installation Instructions - Dry Sprinklers

WARNING: Viking dry sprinklers are to be installed in the 1" outlet (for dry and preaction systems), or run of malleable, ductile iron, or Nibco CPVC* threaded tee fittings (for wet systems) that meet the dimensional requirements of ANSI B16.3 (Class 150), or cast iron threaded tee fittings that meet the dimensional requirements of ANSI B16.4 (Class 125), even at branch line ends. The threaded end of the dry sprinkler is designed to allow the seal to penetrate and extend into the fitting to a predetermined depth. This prevents condensation from accumulating and freezing over the sprinkler seal. ***NOTE: When using CPVC fittings with Viking dry sprinklers, use only new Nibco Model 5012-S-BI. When selecting other CPVC fittings, contact Viking Technical Services.**

1. **DO NOT** install the dry sprinkler into a threaded elbow, coupling, or any other fitting that could interfere with thread penetration. Such installation would damage the brass seal.

2. **DO NOT** install dry sprinklers into couplings or fittings that would allow condensation to accumulate above the seal when the sprinkler is located in an area subject to freezing.

3. **NEVER** try to modify dry sprinklers. They are manufactured for specific "A" or "B" dimensions and cannot be modified.

The dry sprinkler must be installed after the piping is in place to prevent mechanical damage. Before installation, be sure to have the correct sprinkler model and style, with the appropriate "A" or "B" dimension(s), temperature rating, orifice size, and response characteristics. Keep sprinklers with protective caps or bulb shields contained within the caps or shields during installation and testing, and any time the sprinkler is shipped or handled. *Exception: For concealed and adjustable recessed dry sprinklers, the protective caps and shields are removed for installation.*

To install the dry sprinkler, refer to the instructions below and the appropriate sprinkler technical data page for illustrated instructions.

Dry upright sprinklers must be installed above the piping, in the upright position only. When installing dry upright or plain barrel style vertical sidewall sprinklers on piping located close to the ceiling, it may be necessary to lower the sprinkler into the fitting from above the ceiling. When installing dry upright or plain barrel vertical sidewall sprinklers from below the ceiling, verify that the opening in the ceiling is a minimum 1-1/2" (38.1 mm) in diameter.

For dry upright or plain barrel vertical sidewall sprinklers in the upright position: First, install the escutcheon (if used) over the threaded end of the sprinkler barrel. Slide the escutcheon past the external threads. NOTE: When installing the dry upright or plain barrel vertical sidewall sprinkler from above the ceiling, it will be necessary to install the escutcheon after lowering the threaded end of the sprinkler through the ceiling penetration.

A. **For all dry sprinklers:** Apply a small amount of pipe-joint compound or tape to the external threads of the sprinkler barrel only, taking care not to allow a build-up of compound or tape over the brass inlet and seal. **NOTE:** Sprinklers with protective caps or bulb shields must be contained within the caps or shields before applying pipe-joint compound or tape.



TECHNICAL DATA

SPRINKLER GENERAL CARE, INSTALLATION, AND MAINTENANCE GUIDE

The Viking Corporation, 210 N Industrial Park Drive, Hastings MI 49058

Telephone: 269-945-9501 Technical Services: 877-384-5464 Fax: 269-818-1680 Email: techsvcs@vikingcorp.com

Visit the Viking website for the latest edition of this technical data page.

- B. Refer to the appropriate sprinkler technical data page to determine the correct sprinkler wrench for the model of sprinkler used.
- C. Install the dry sprinkler on the piping using the special dry sprinkler wrench only, while taking care not to damage the sprinkler.
NOTE: Thread the sprinkler into the fitting hand tight, plus 1/2 turn with the dry sprinkler wrench.
- D. *For adjustable standard and adjustable recessed dry pendent and sidewall sprinklers: Escutcheons can be installed after the sprinklers have been installed onto the piping. Refer to the appropriate sprinkler technical data page for escutcheon installation instructions and illustrations.*

D. Installation Instructions - Testing

- 4. After installation, the entire sprinkler system must be tested. The test must be conducted to comply with the installation standards. Viking *high pressure* sprinklers may be hydrostatically tested at a maximum of 300 psi (20.7 bar) for limited periods of time (two hours), for the purpose of acceptance by the Authority Having Jurisdiction.
 - a. Make sure the sprinkler is properly tightened. If a thread leak occurs, normally the sprinkler must be removed, new pipe-joint compound or tape applied, and then reinstalled. This is due to the fact that when the joint seal is damaged, the sealing compound or tape is washed out of the joint. Air testing [do not exceed 40 psi (2.76 bar)] the sprinkler piping prior to testing with water may be considered in areas where leakage during testing must be prevented. Refer to the Installation Standards and the Authority Having Jurisdiction.
 - b. **Remove plastic protective sprinkler caps or bulb shields AFTER the wall or ceiling finish work is completed where the sprinkler is installed and there no longer is a potential for mechanical damage to the sprinkler operating elements.** To remove the bulb shields, simply pull the ends of the shields apart where they are snapped together. To remove caps from frame style sprinklers, turn the caps slightly and pull them off the sprinklers. **SPRINKLER CAPS OR BULB SHIELDS MUST BE REMOVED FROM SPRINKLERS BEFORE PLACING THE SYSTEM IN SERVICE!** Retain a protective cap or shield in the spare sprinkler cabinet.
- 5. For flush style sprinklers: the ceiling ring can now be installed onto the sprinkler body. Align the ceiling ring with the sprinkler body and thread or push it on (depends on sprinkler model) until the outer flange touches the surface of the ceiling. Note the maximum adjustment is 1/4" (6.35 mm). DO NOT MODIFY THE UNIT. If necessary, re-cut the sprinkler drop nipple as required.
- 6. For concealed sprinklers: the cover assembly can now be attached.
 - a. Remove the cover from the protective box, taking care not to damage the cover plate assembly.
 - b. Gently place the base of the cover plate assembly over the sprinkler protruding through the opening in the ceiling.
 - c. Push the cover plate assembly onto the sprinkler until the unfinished brass flange of the cover plate base (or the cover adapter, if used) touches the surface of the ceiling.
 - d. Refer to the applicable technical data sheet to determine the maximum adjustment available for concealed sprinklers. DO NOT MODIFY THE UNIT. If necessary, re-cut the sprinkler drop nipple.

NOTE: If it is necessary to remove the entire sprinkler unit, the system must be taken out of service. See section 6. INSPECTIONS, TESTS AND MAINTENANCE and follow all warnings and instructions.

5. OPERATION

Refer to the appropriate sprinkler technical data page(s). During fire conditions, the operating element fuses or shatters (depending on the type of sprinkler), releasing the pip cap and sealing assembly. Water flowing through the sprinkler orifice strikes the sprinkler deflector, forming a uniform spray pattern to extinguish or control the fire.

IMPORTANT: Always refer to Bulletin Form No. F_091699 - Care and Handling of Sprinklers. Viking sprinklers are to be installed in accordance with the latest edition of Viking technical data, the appropriate standards of NFPA, FM Global, LPCB, APSAD, VdS or other similar organizations, and also with the provisions of governmental codes, ordinances, and standards, whenever applicable. The sprinkler technical data page may contain installation requirements specific for the sprinkler model selected. The use of certain types of sprinklers may be limited due to occupancy and hazard. Refer to the Authority Having Jurisdiction prior to installation.



TECHNICAL DATA

SPRINKLER GENERAL CARE, INSTALLATION, AND MAINTENANCE GUIDE

The Viking Corporation, 210 N Industrial Park Drive, Hastings MI 49058

Telephone: 269-945-9501 Technical Services: 877-384-5464 Fax: 269-818-1680 Email: techsvcs@vikingcorp.com

Visit the Viking website for the latest edition of this technical data page.

6. INSPECTIONS, TESTS AND MAINTENANCE

NOTICE: Refer to NFPA 25 for Inspection, Testing and Maintenance requirements. **NOTICE:** The owner is responsible for having the fire-protection system and devices inspected, tested, and maintained in proper operating condition in accordance with this guide, and applicable NFPA standards. In addition, the Authority Having Jurisdiction may have additional maintenance, testing, and inspection requirements that must be followed.

- A. Sprinklers must be inspected on a regular basis for corrosion, mechanical damage, obstructions, paint, etc. Frequency of inspections may vary due to corrosive atmospheres, water supplies, and activity around the sprinkler unit.
- B. Sprinklers or cover plate assemblies that have been field painted, caulked, or mechanically damaged must be replaced immediately. Sprinklers showing signs of corrosion shall be tested and/or replaced immediately as required. Installation standards require sprinklers to be tested and, if necessary, replaced after a specified term of service. Refer to NFPA 25 and the Authority Having Jurisdiction for the specified period of time after which testing and/or replacement is required. Never attempt to repair or reassemble a sprinkler. Sprinklers and cover assemblies that have operated cannot be reassembled or re-used, but must be replaced. When replacement is necessary, use only new sprinklers and cover assemblies with identical performance characteristics.
- C. The sprinkler discharge pattern is critical for proper fire protection. Therefore, nothing should be hung from, attached to, or otherwise obstruct the discharge pattern. All obstructions must be immediately removed or, if necessary, additional sprinklers installed.
- D. When replacing existing sprinklers, the system must be removed from service. Refer to the appropriate system description and/or valve instructions. Prior to removing the system from service, notify all Authorities Having Jurisdiction. Consideration should be given to employment of a fire patrol in the affected area.
 1. Remove the system from service, drain all water, and relieve all pressure on the piping.
 - 2a. For frame-style sprinklers, use the special sprinkler wrench to remove the old sprinkler by turning it counterclockwise to unthread it from the piping.
 - 2b. For flush and concealed style sprinklers: Remove the ceiling ring or cover plate assembly before unthreading the sprinkler body from the piping. Ceiling rings and cover plates can be removed either by gently unthreading them or pulling them off the sprinkler body (depends on the sprinkler model used). After the ceiling ring or cover plate assembly has been removed from the sprinkler body, place the plastic protective cap (from the spare sprinkler cabinet) over the sprinkler to be removed and then fit the sprinkler wrench over the cap. Then use the wrench to unthread the sprinkler from the piping. *Exception: Domed concealed sprinklers are removed without the plastic cap.*
 3. Install the new sprinkler unit by following the instructions in section 4. INSTALLATION. Care must be taken to ensure that the replacement sprinkler is the proper model and style, with the correct K-Factor, temperature rating, and response characteristics. A fully stocked spare sprinkler cabinet should be provided for this purpose. For flush or concealed sprinklers: stock of spare ceiling rings or cover plates should also be available in the spare sprinkler cabinet.
- E. Place the system back in service and secure all valves. Check for and repair all leaks. Sprinkler systems that have been subjected to a fire must be returned to service as soon as possible. The entire system must be inspected for damage, and repaired or replaced as necessary. Sprinklers that have been exposed to corrosive products of combustion or high ambient temperatures, but have not operated, should be replaced. Refer to the Authority Having Jurisdiction for minimum replacement requirements.

7. AVAILABILITY

Viking sprinklers are available through a network of domestic and international distributors. See The Viking Corporation web site for the closest distributor or contact The Viking Corporation.

8. GUARANTEE

For details of warranty, refer to Viking's current list price schedule or contact Viking directly.

**BULLETIN****REGULATORY AND HEALTH
WARNINGS**

The Viking Corporation, 210 N Industrial Park Drive, Hastings MI 49058

Telephone: 269-945-9501 Technical Services: 877-384-5464 Fax: 269-818-1680 Email: techsvcs@vikingcorp.com

Visit the Viking website for the latest edition of this technical data page www.vikinggroupinc.com

1. DESCRIPTION

Regulatory and Health Warnings applying to materials used in the manufacture and construction of fire protection products are provided herein as they relate to legally mandated jurisdictional regions.

⚠ WARNING**STATE OF CALIFORNIA, USA**

Installing or servicing fire protection products such as sprinklers, valves, piping etc. can expose you to chemicals including, but not limited to, lead, nickel, butadiene, titanium dioxide, chromium, carbon black, and acrylonitrile which are known to the State of California to cause cancer or birth defects or other reproductive harm.

For more information, go to www.P65Warnings.ca.gov

2. WARRANTY TERMS AND CONDITIONS

For details of warranty, refer to Viking's current list price schedule at www.vikinggroupinc.com or contact Viking directly.

PIPE

Schedule 10 and Schedule 40

FM Approved and UL Listed Sprinkler Pipe

Bull Moose Tube Company is a recognized producer of quality pipe products. Our Schedule 10 and Schedule 40 are FM Approved and UL Listed (for U.S. and Canada), even though these products do not require separate approvals and listings. Bull Moose Tube made the decision to have them approved and listed for your peace of mind. Our Sch. 10 and Sch. 40 have been through the same rigorous testing as our other fine pipe products.

Bull Moose Tube's Sch. 10 and Sch. 40 pipes are made to ASTM A135 and ASTM A795. These products are typically supplied with our protective coating but can be supplied without the coating so they can be hot-dip galvanized to meet FM requirements for use in dry systems in accordance with the zinc coating specifications of ASTM A795 or ASTM A53.

Schedule 10 Pipe

Nominal Pipe Size (in)	Nominal O.D. (in)	Nominal I.D. (in)	Weight/Ft	Bundle Size
1	1.315	1.097	1.41 lbs/ft	91
1 1/4	1.660	1.442	1.81 lbs/ft	61
1 1/2	1.900	1.682	2.09 lbs/ft	61
2	2.375	2.157	2.64 lbs/ft	37
2 1/2	2.875	2.635	3.53 lbs/ft	30
3	3.500	3.260	4.34 lbs/ft	19
4	4.500	4.260	5.62 lbs/ft	19

Schedule 40 Pipe

Nominal Pipe Size (in)	Nominal O.D. (in)	Nominal I.D. (in)	Weight/Ft	Bundle Size
1	1.315	1.049	1.68 lbs/ft	70
1 1/4	1.660	1.380	2.27 lbs/ft	51
1 1/2	1.900	1.610	2.72 lbs/ft	44
2	2.375	2.067	3.66 lbs/ft	30
2 1/2	2.875	2.468	5.80 lbs/ft	30
3	3.500	3.068	7.58 lbs/ft	19
4	4.500	4.260	10.80 lbs/ft	19

PIPE PREPARATION

For proper operation, all pipe surfaces should be cleaned prior to installation. In order to provide a leak-tight seat for the gasket, pipe surfaces should be free from indentations and projections from the end of the pipe to the groove. All loose paint, scale, dirt, chips, grease, and rust must be removed prior to installation. Failure to take these important steps may result in improper coupling assembly, causing leakage. Also, check the manufacturer's instructions for the specific fitting used.



A CAPARO company

1819 Clarkson Road
 Chesterfield, MO 63017
 (800) 325-4467
 FAX: (636) 537-2645
www.bullmoosetube.com
 e-mail: sales@bullmoosetube.com

For additional information,
 contact your salesperson
 today at (800) 325-4467 or
 (636) 537-2600 in the USA,
 or from Canada
 call (800) 882-4666



HANGER MATERIAL

SIDEWINDER® FOR STEEL - Horizontal Application



Application	Product Features
	<ul style="list-style-type: none"> Made with TekS® self-drilling fasteners - no pre-drilling required. Installs into steel range from 20 gauge – 1/2" thicknesses. A standard screwgun with a depth sensitive nosepiece should be used to install TekS. For optimal fastener performance, the screwgun should be a minimum of 6 amps and have an RPM range of 0-2500. Saves time from traditional methods. Reduces installation costs. Quick to install using the Sammys Nut Driver with an 18V cordless drill/driver. Manufactured in the U.S.A.

Watch a video demonstration at www.itwbuildex.com

Approvals	Rod Size	Part Number	Model	Screw Descriptions	Ultimate Pullout (lbs)	UL Test Load (lbs)	FM Test Load (lbs)	Min Thickness	Max Thickness	Box Qty	Case Qty
HORIZONTAL MOUNT											
	1/4"	8047957	SWD 100	1/4-14 x 1" TEKS 3	1477 (16 ga.)			.060"-16 ga	3/16"	25	125
	1/4"	8049957	SWDR 100 *	1/4-20 x 1" TEKS 3	1900 (20 ga.)			.036"-20 ga	3/16"	25	125
	3/8"	8050957	SWD 10	1/4-14 x 1" TEKS 3	1477 (16 ga.)			.060"-16 ga	3/16"	25	125
	3/8"	8080925	SWD 10-SS	1/4-14 x 1" TEKS 3	1477 (16 ga.)			.060"-16 ga	3/16"	25	125
	3/8"	8052957	SWD 20	1/4-14 x 2" TEKS 3	1477 (16 ga.)			.060"-16 ga	3/16"	25	125
	3/8"	8055957	SWDR 1 *	1/4-20 x 1" TEKS 3	1900 (20 ga.)	1500	1475	.036"-20 ga	3/16"	25	125
	3/8"	8054957	SWDR 1-1/2 *	12-24 x 1-1/2" TEKS 5	2375 (3/16")	1500	1475	.188"-3/16"	1/2"	25	125
	3/8"	8056957	SWDR 516 *	5/16-18 x 1-1/4" TEKS 3	2480 (20 ga.)	1500	1475	.036"-20 ga	3/16"	25	125
	3/8"	8057957	SWT 15	12-24 x 1-1/2" TEKS 5	2375 (3/16")			.188"-3/16"	1/2"	25	125

*Includes retaining nut

SAMMYS SWIVEL HEAD™ FOR STEEL - Swivel Application



Application	Product Features
	<ul style="list-style-type: none"> Eliminates distortion of threaded rod in sloped roof applications. Accommodates 3-1/2 x 12 pitch. Installs into angled z-purlin; allows threaded rod to hang plumb. Allows 17° deflection from vertical. Manufactured in the U.S.A.

Watch a video demonstration at www.itwbuildex.com

Approvals	Rod Size	Part Number	Model	Screw Descriptions	Ultimate Pullout (lbs)	UL Test Load (lbs)	FM Test Load (lbs)	Min Thick	Max Thick	Box Qty	Case Qty
SWIVEL MOUNT											
	3/8"	8137957	SH-DSTR 1*	1/4-20 X 1" TEKS 3	3220 (3/16")	1500	1475	.035"	3/16"	25	125
	3/8"	8268957	SH-TEK 50	12-24 x 1-3/4" TEKS 5	2368 (1/2" steel Vertical) 1306 (45° off Vertical) 2281 (3/16" HSS) 1585 (3/16" HSS 45° off Vertical)	1500 (Vertical) 850 (45° off Vertical)	4" 2-1/2"	3/16"	1/2"	25	125
	1/2"	8270957	SH-TEK 5.0	12-24 x 1-3/4" TEKS 5	2368 (1/2" steel Vertical) 1306 (45° off Vertical) 2281 (3/16" HSS) 1585 (3/16" HSS 45° off Vertical)			3/16"	1/2"	25	125

*Does not comply with ROHS requirements / Includes retaining nut

Threaded Rods

Low Carbon Steel Threaded Rod

The most economical and most common form of Threaded Rod. Typically used by the plumbing and contracting trades. Used in maintenance departments in various applications including hanging, mounting, bracing, supporting, and fastening applications.

- Low carbon steel according to ASTM A307, Grade A requirements
- Conforms to ASME B18.31.3
- Class 1A rolled threads
- Zinc Plated according to Fe/Zn 3AT Per ASTM F1941
- Hot Dip Galvanized according to ASTM A153 or F2329
- 60,000 psi Min. Tensile Strength



FASTENERS

		1 ft				2 ft				3 ft				6 ft				10 ft				12 ft								
		Plain		Zinc		Plain		Zinc		Plain		Zinc		Hot Dip Galvanized		Plain		Zinc		Plain		Zinc		Hot Dip Galvanized		Plain		Zinc		Hot Dip Galvanized
Diameter	Thread Size	Part No.	Part No.	Part No.	Part No.	Part No.	Part No.	Part No.	Part No.	Part No.	Part No.	Part No.	Part No.	Part No.	Part No.	Part No.	Part No.	Part No.	Part No.	Part No.	Part No.	Part No.	Part No.	Part No.	Part No.	Part No.	Part No.	Part No.	Part No.	Part No.
#6	32	-	-	-	-	47002	47052	-	-	47102	47152	-	-	-	-	-	-	-	-	-	-	-	-	-	-	-	-	-	-	
#8	32	-	-	-	-	47003	47053	-	-	47103	47153	-	-	47136	47186	-	-	-	-	-	-	-	-	-	-	-	-	-	-	
#10	24	-	-	-	-	47004	47054	-	-	47104	47154	-	-	47137	47187	-	-	-	-	-	-	-	-	-	-	-	-	-	-	
#12	24	-	-	-	-	47006	47056	-	-	-	47156	-	-	-	-	-	-	-	-	-	-	-	-	-	-	-	-	-	-	
1/4"	20	0156376	0156317	0156377	0156318	47007	47057	-	-	47107	47157	-	-	47140	47190	-	-	47207	47257	-	-	-	-	-	-	-	-	-	-	
5/16"	18	0156378	0156319	0156379	0156320	47009	47059	-	-	47109	47159	-	-	47141	47191	-	-	47209	47259	-	-	-	-	-	-	-	-	-	-	
3/8"	16	0156380	0156321	0156381	0156322	47011	47061	47602	47111	47161	47618	47142	47192	47634	47211	47261	47650	-	-	-	-	-	-	-	-	-	-	-	-	
7/16"	14	0156382	0156323	0156383	0156324	47013	47063	0156404	47113	47163	-	47143	47193	-	47213	47263	-	-	-	-	-	-	-	-	-	-	-	-	-	
1/2"	13	0156384	0156325	0156385	0156326	47015	47065	47604	47115	47165	47620	47144	47194	47636	47215	47265	47652	-	-	-	-	-	-	-	-	-	-	-	-	
9/16"	12	0156386	0156327	0156387	0156328	47017	47067	-	47117	47167	-	47145	47195	-	47217	47267	-	-	-	-	-	-	-	-	-	-	-	-	-	
5/8"	11	0156388	0156329	0156389	0156330	47019	47069	47606	47119	47169	47622	47146	47196	47638	47219	47269	47654	-	-	-	-	-	-	-	-	-	-	-	-	
3/4"	10	0156390	0156331	0156391	0156332	47021	47071	47607	47121	47171	47623	47147	47197	47639	47221	47271	47655	-	-	-	-	-	-	-	-	-	-	-	-	
7/8"	9	0156392	0156333	0156393	0156334	47023	47073	0156408	47123	47173	47624	47148	47198	47640	47223	47273	47656	-	-	-	-	-	-	-	-	-	-	-	-	
1"	8	0156394	0156335	0156395	0156336	47025	47075	47609	47125	47175	47625	47149	47199	47641	47225	47275	47657	-	-	-	-	-	-	-	-	-	-	-	-	
1-1/8"	7	-	-	-	-	47027	47077	-	47127	47177	47626	47150	47200	47642	47227	47277	47658	-	-	-	-	-	-	-	-	-	-	-	-	
1-1/4"	7	-	-	-	-	47028	47078	47611	47128	47178	47627	47151	47201	47643	47228	47278	47659	-	-	-	-	-	-	-	-	-	-	-	-	
1-3/8"	6	-	-	-	-	47029	47079	-	47129	47179	-	47233	47237	47644	47229	47279	47660	-	-	-	-	-	-	-	-	-	-	-	-	
1-1/2"	6	-	-	-	-	47030	47080	-	47130	47180	47629	47234	47238	47645	47230	47280	47661	-	-	-	-	-	-	-	-	-	-	-	-	
1-3/4"	5	-	-	-	-	47031	47081	-	47131	47181	47630	47235	47239	47646	47231	47281	47662	-	-	-	-	-	-	-	-	-	-	-	-	
2"	4.5	-	-	-	-	47032	47082	-	47132	47182	-	47236	47240	47647	47232	47282	47663	-	-	-	-	-	-	-	-	-	-	-	-	

		3 ft		6 ft		12 ft	
		Plain	Zinc	Plain	Zinc	Plain	Zinc
Diameter	Thread Size	Part No.	Part No.	Part No.	Part No.	Part No.	Part No.
#10	32	47005	47055	47105	47155	-	-
1/4"	28	47008	47058	47108	47158	47208	47258
5/16"	24	47010	47060	47110	47160	47210	47260
3/8"	24	47012	47062	47112	47162	47212	47262
7/16"	20	47014	47064	47114	47164	47214	47264
1/2"	20	47016	47066	47116	47166	47216	47266
9/16"	18	47018	47068	47118	47168	-	47268
5/8"	18	47020	47070	47120	47170	47220	47270
3/4"	16	47022	47072	47122	47172	47222	47272
7/8"	14	47024	47074	47124	47174	47224	47274
1"	14	47026	47076	47126	47176	47226	47276
1-1/8"	12	47033	47083	47133	47183	47094	-
1-1/4"	12	47034	47084	47134	47184	47095	47098
1-1/2"	12	47035	47085	47135	47185	47096	-

Left Hand Low Carbon Steel Threaded Rod



The most economical and most common form of Threaded Rod. Typically used by the plumbing and contracting trades. Used in maintenance departments in various applications; left hand threading. Plain Finish, or bare metal finish which may contain a light coating of oil.

- 6 foot lengths

Thread - Left Hand - Coarse		
Diameter	Thread Size	Plain Part No.
1/4"	20	47302
5/16"	18	47303
3/8"	16	47304
1/2"	13	47306
5/8"	11	47308
3/4"	10	47309
7/8"	9	47310
1"	8	47311
1-1/8"	7	47312
1-1/4"	7	47313
1-1/2"	6	47315
2"	4.5	47318

Metric Threaded Rod

- Made from heat treated Class 8.8 steel.



		Class 4.6		Class 8.8	
		Plain	Zinc	Plain	Zinc
Diameter	Thread Size	Part No.	Part No.	Part No.	Part No.
M2	0.4	-	0162065	-	-
M3	0.5	-	0162068	-	-
M4	0.7	47556	0162070	-	-
M5	0.8	47570	0162071	-	-
M6	1.0	47571	0162072	47870	-
M8	1.25	47572	0162073	47872	-
M10	1.5	47573	0162075	47873	-
M12	1.75	47574	0162078	47874	-
M14	2.0	47575	0162081	47875	-
M16	2.0	47576	0162083	47876	-
M18	2.5	47577	0162085	47877	-
M20	2.5	47578	0162086	47878	-
M22	2.5	47579	-	47879	-
M24	3.0	47580	0162088	47880	-

		Class 4.6		Class 8.8	
		Plain	Zinc	Plain	Zinc
Diameter	Thread Size	Part No.	Part No.	Part No.	Part No.
M27	3.0	47581	0162089	47881	-
M30	3.5	47582	0162090	47882	-
M33	3.5	47733	-	47883	-
M36	4.0	47583	-	47884	-
M39	4.0	47734	-	47885	-
M42	4.5	47735	-	47886	-
M48	5.0	47737	-	-	-

Thread - Fine		
Diameter	Thread Size	Class 4.6 Zinc Part No.
M8	1.0	0162074
M10	1.0	0162077
M10	1.25	0162076
M12	1.25	0162080
M12	1.5	0162079
M14	1.5	0162082
M16	1.5	0162084

HOW DO YOU PREFER TO BUY?

Local Store | Personal Service | Inventory Solutions | fastenal.com

100 Heavy Duty Loop Hanger



- Recommended for the suspension of stationary non-insulated pipe lines
- Conforms with Federal Specification WW-H-171 (Type 10), Manufacturers Standardization Society (MSS) SP-58 (Type 10)

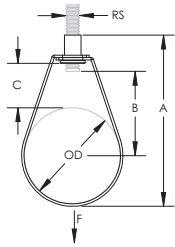

Material: Steel
Finish: Pregalvanized

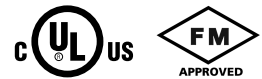

Part Number	Pipe Size	Outer Diameter OD	Rod Size RS	A	B	C	Static Load F
1000250EG	2 1/2"	2 7/8"	1/2"	5 5/8"	2 9/16"	1 1/2"	1,000 lb
1000300EG	3"	3 1/2"	1/2"	6 9/16"	3 3/16"	1 13/16"	1,000 lb
1000350EG	3 1/2"	4"	1/2"	7"	3 3/8"	1 3/4"	1,000 lb
1000400EG	4"	4 1/2"	5/8"	7 3/4"	3 11/16"	1 7/8"	1,100 lb
1000500EG	5"	5 9/16"	5/8"	9 1/8"	4 9/16"	2 3/16"	1,100 lb
1000600EG	6"	6 5/8"	3/4"	10 5/8"	5 3/16"	2 3/8"	1,250 lb
1000800EG	8"	8 5/8"	7/8"	13 1/8"	6 9/16"	2 7/8"	1,250 lb

FM is a registered certification mark of FM Approvals LLC, LTD. UL, UR, cUL, cUR, cULus and cURus are registered certification marks of UL LLC.

WARNING

Pentair products shall be installed and used only as indicated in Pentair's product instruction sheets and training materials. Instruction sheets are available at erico.pentair.com and from your Pentair customer service representative. Improper installation, misuse, misapplication or other failure to completely follow Pentair's instructions and warnings may cause product malfunction, property damage, serious bodily injury and death and/or void your warranty.

© 2017 Pentair All rights reserved

Pentair, CADDY, CADWELD, CRITEC, ERICO, ERIFLEX, ERITECH and LENTON are owned by Pentair or its global affiliates.

All other trademarks are the property of their respective owners. Pentair reserves the right to change specifications without prior notice.



300 Universal Beam Clamp



- Conforms with Federal Specification WW-H-171 (Type 23), Manufacturers Standardization Society ANSI®/MSS-SP-58 (Type 19 and 23)

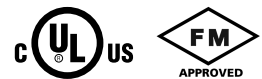
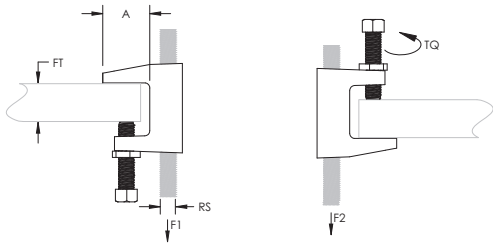

Material: Steel

Part Number	Rod Size RS	Flange Thickness FT	A	Torque TQ	Static Load 1 F1	Static Load 2 F2	Certifications	Standard Packaging Quantity
Finish: Plain								
3000037PL	3/8"	13/16" Max	1 1/8"	5 ft lb	500 lb	250 lb	cULus, FM	100 pc
3000050PL	1/2"	13/16" Max	1 1/8"	8 ft lb	950 lb	760 lb	cULus, FM	50 pc
3000062PL	5/8"	13/16" Max	1 1/8"	5 ft lb	950 lb	760 lb	cULus	50 pc
3000075PL	3/4"	13/16" Max	1 1/8"	5 ft lb	950 lb	760 lb	cULus	50 pc
3000087PL	7/8"	13/16" Max	1 1/8"	5 ft lb	950 lb	760 lb	cULus	50 pc
Finish: Electrogalvanized								
3000037EG	3/8"	13/16" Max	1 1/8"	5 ft lb	500 lb	250 lb	cULus, FM	100 pc
3000050EG	1/2"	13/16" Max	1 1/8"	8 ft lb	950 lb	760 lb	cULus, FM	50 pc
3000062EG	5/8"	13/16" Max	1 1/8"	5 ft lb	950 lb	760 lb	cULus	50 pc
3000075EG	3/4"	13/16" Max	1 1/8"	5 ft lb	950 lb	760 lb	cULus	50 pc
3000087EG	7/8"	13/16" Max	1 1/8"	5 ft lb	950 lb	760 lb	cULus	50 pc

Setscrew must be tightened and torqued onto the sloped side of the I-beam.

Recognizing that torque wrenches are generally not used or available on many job sites, the setscrew should be tightened so it contacts the I-beam and then an additional 1/4 to 1/2 turn added.

ANSI is a registered trademark of American National Standards Institute. FM is a registered certification mark of FM Approvals LLC, LTD. UL, UR, cUL, cUR, cULus and cURus are registered certification marks of UL LLC.

WARNING

Pentair products shall be installed and used only as indicated in Pentair's product instruction sheets and training materials. Instruction sheets are available at erico.pentair.com and from your Pentair customer service representative. Improper installation, misuse, misapplication or other failure to completely follow Pentair's instructions and warnings may cause product malfunction, property damage, serious bodily injury and death and/or void your warranty.

© 2017 Pentair All rights reserved

Pentair, CADDY, CADWELD, CRITEC, ERICO, ERIFLEX, ERITECH and LENTON are owned by Pentair or its global affiliates.

All other trademarks are the property of their respective owners. Pentair reserves the right to change specifications without prior notice.



FITTINGS

FIG. 3201

90° Elbow

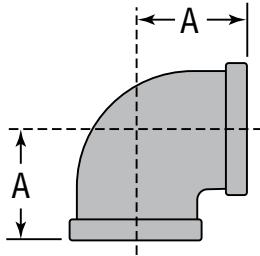

For Listings/Approval Details and Limitations, visit our website at www.anvilintl.com or contact an Anvil® Sales Representative.

FIGURE 3201 - 90° ELBOW

Nominal Size	Maximum Working Pressure▲	Dimension A	Approx. Wt. Each
<i>In. (mm)</i>	<i>PSI (kPa)</i>	<i>In. (mm)</i>	<i>Lbs. (kg)</i>
1 20	500 3450	1.50 38.10	0.62 0.28
1¼ 32	500 3450	1.75 44.45	0.90 0.41
1½ 40	500 3450	1.94 49.276	1.20 0.54
2 50	500 3450	2.25 57.15	1.85 0.84

▲ – Working Pressure Ratings are for reference only and based on Sch. 40 pipe. For the latest UL/ULC, and FM pressure ratings versus pipe schedule, please visit anvilintl.com or contact your local Anvil Representative.

MATERIAL SPECIFICATIONS

Dimensions: ASME B16.3

Material: ASTM A536 Grade 65-45-12

Finish: Black

Threads: NPT per ASME B1.20.1

Agency Approvals: All ductile iron threaded fittings are UL/ULC Listed and FM Approved.

NOTICE: Ductile iron fittings have higher tensile strength than that of steel pipe. Therefore, over tightening can cause damage to pipe threads which may cause leakage. Ductile iron fittings should be tightened approximately three turns beyond hand tight, but no more than four turns.

PROJECT INFORMATION

APPROVAL STAMP

Project:	<input type="checkbox"/> Approved
Address:	<input type="checkbox"/> Approved as noted
Contractor:	<input type="checkbox"/> Not approved
Engineer:	Remarks:
Submittal Date:	
Notes 1:	
Notes 2:	

FIG. 3221R

Reducing Coupling

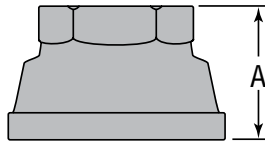

For Listings/Approval Details and Limitations, visit our website at www.anvilintl.com or contact an Anvil® Sales Representative.

FIGURE 3221R - REDUCING COUPLING			
Nominal Size	Maximum Working Pressure▲	Dimension A	Approx. Wt. Each
<i>In. (mm)</i>	<i>PSI (kPa)</i>	<i>In. (mm)</i>	<i>Lbs. (kg)</i>
1 x 1/2 25 x 15	500 3450	1.69 42.92	0.39 0.18
1 x 3/4 25 x 20	500 3450	1.69 42.92	0.53 0.24

▲ - Working Pressure Ratings are for reference only and based on Sch. 40 pipe. For the latest UL/ULC, and FM pressure ratings versus pipe schedule, please visit anvilintl.com or contact your local Anvil Representative.

MATERIAL SPECIFICATIONS

Dimensions: ASME B16.3

Material: ASTM A536 Grade 65-45-12

Finish: Black

Threads: NPT per ASME B1.20.1

Agency Approvals: All ductile iron threaded fittings are UL/ULC Listed and FM Approved.

NOTICE: Ductile iron fittings have higher tensile strength than that of steel pipe. Therefore, over tightening can cause damage to pipe threads which may cause leakage. Ductile iron fittings should be tightened approximately three turns beyond hand tight, but no more than four turns.

PROJECT INFORMATION		APPROVAL STAMP	
Project:		<input type="checkbox"/> Approved	
Address:		<input type="checkbox"/> Approved as noted	
Contractor:		<input type="checkbox"/> Not approved	
Engineer:		Remarks:	
Submittal Date:			
Notes 1:			
Notes 2:			

VALVES

Model DPV-1 Dry Pipe Valve External Resetting

General Description

The TYCO Model DPV-1 Dry Pipe Valves are differential valves used to automatically control the flow of water into dry pipe fire protection sprinkler systems upon operation of one or more automatic sprinklers. The DPV-1 also provides for actuation of fire alarms upon system operation. The Model DPV-1 features are as follows:

- External reset.
- 250 psi (17,2 bar) pressure rating.
- Unique offset single clapper design enabling a simple compact valve to minimize installation labor.
- Ductile iron construction to ensure a lightweight valve to minimize shipping cost.
- A variety of inlet and outlet connections.
- Compact, Pre-Trimmed, and Semi-Assembled, easy to operate valve trim.
- Simple reset procedure through the elimination of priming water.

Dry pipe sprinkler systems are used in unheated warehouses, parking garages, store windows, attic spaces, loading docks, and other areas exposed to freezing temperatures, where water filled pipe cannot be utilized. When set for service, the dry pipe sprinkler system is pressurized with air (or nitrogen). The loss of pressure through an operated automatic sprinkler in response to heat from a fire permits the DPV-1 Dry Pipe Valve to open and allow a flow of water into the sprinkler system piping. Table B establishes the minimum required system air pressure that includes a safety factor to help prevent false operations that might occur due to water supply fluctuations.

NOTICE

The Model DPV-1 Dry Pipe Valves described herein must be installed and maintained in compliance with this document, as well as with the



Available Sizes and End Connections

End Connection	Nominal Valve Size			
	2-1/2 Inch (DN65)	3 Inch (DN80)	4 Inch (DN100)	6 Inch (DN150)
Flange x Flange	N/A	N/A	•	•
Flange x Groove	N/A	N/A	•	•
Groove x Groove	•	•	•	•

• = Available
N/A = Not Available

applicable standards of the National Fire Protection Association, in addition to the standards of any other authorities having jurisdiction. Failure to do so may impair the performance of these devices.

The owner is responsible for maintaining their fire protection system and devices in proper operating condition. Contact the installing contractor or product manufacturer with any questions.

Technical Data

Approvals
UL and C-UL Listed
FM Approved
NYC Approved

Dry Pipe Valve

The TYCO Model DPV-1 Dry Pipe Valves shall be installed in the vertical orientation only (supply at bottom flowing upward) and are rated for use at a maximum service pressure of 250 psi (17,2 bar). Valve and trim dimensions are shown in Figure 6.

Flanged connections are available and drilled per ANSI, ISO, AS, and JIS specifications (Ref. Table A). The grooved outlet connections, as applicable, are cut in accordance with standard groove specifications for steel pipe. They are suitable for use with grooved end pipe couplings that are listed or approved for fire protection system service. Available combinations of inlet and outlet connections are described in the

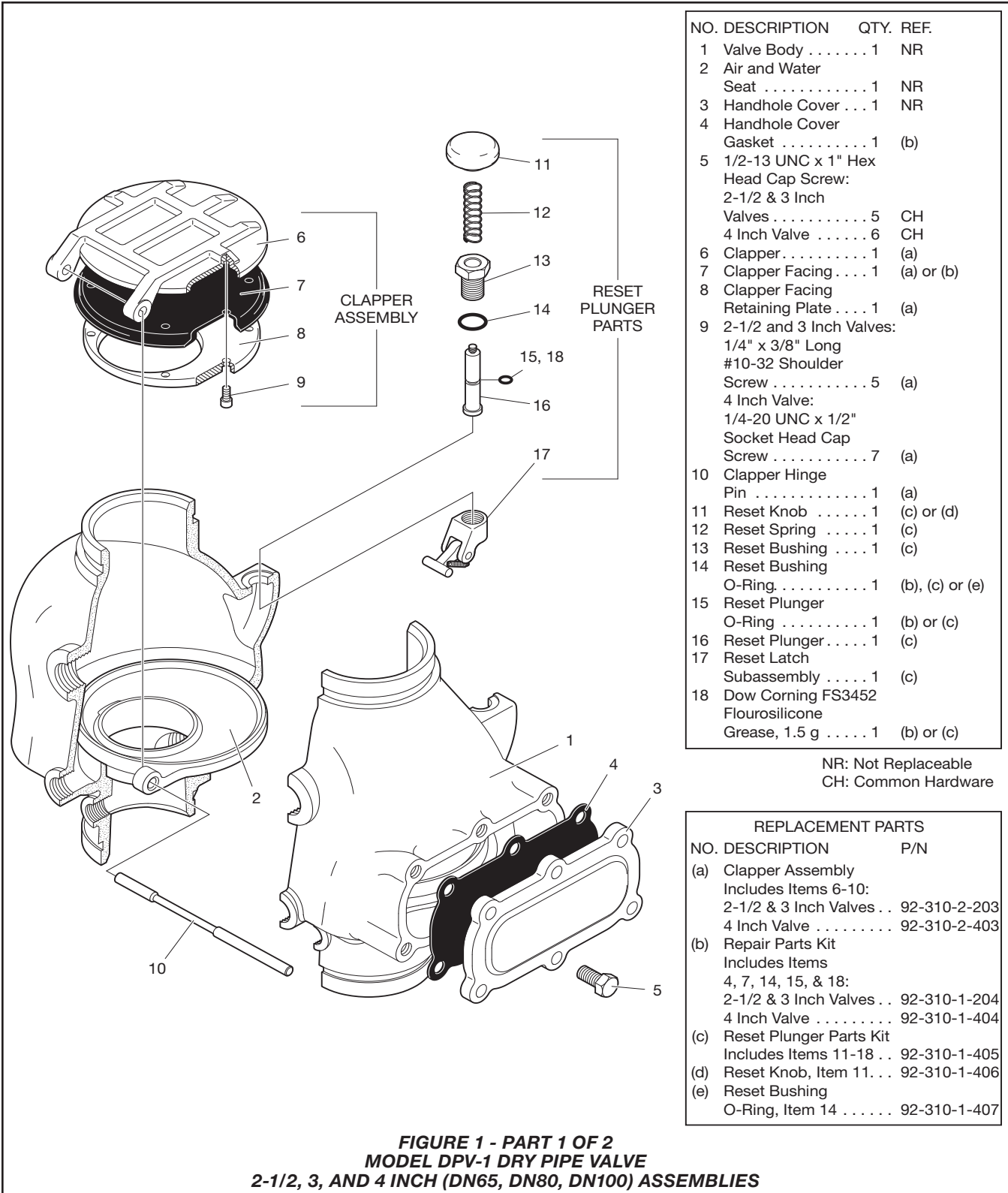

NO.	DESCRIPTION	QTY.	REF.
1	Valve Body	1	NR
2	Air and Water Seat	1	NR
3	Handhole Cover	1	NR
4	Handhole Cover Gasket	1	(b)
5	1/2-13 UNC x 1" Hex Head Cap Screw: 2-1/2 & 3 Inch Valves	5	CH
6	4 Inch Valve	6	CH
6	Clapper	1	(a)
7	Clapper Facing	1	(a) or (b)
8	Clapper Facing Retaining Plate	1	(a)
9	2-1/2 and 3 Inch Valves: 1/4" x 3/8" Long #10-32 Shoulder Screw	5	(a)
	4 Inch Valve: 1/4-20 UNC x 1/2" Socket Head Cap Screw	7	(a)
10	Clapper Hinge Pin	1	(a)
11	Reset Knob	1	(c) or (d)
12	Reset Spring	1	(c)
13	Reset Bushing	1	(c)
14	Reset Bushing O-Ring	1	(b), (c) or (e)
15	Reset Plunger O-Ring	1	(b) or (c)
16	Reset Plunger	1	(c)
17	Reset Latch Subassembly	1	(c)
18	Dow Corning FS3452 Flourosilicone Grease, 1.5 g	1	(b) or (c)

NR: Not Replaceable
 CH: Common Hardware

REPLACEMENT PARTS	
NO.	P/N
(a)	Clapper Assembly Includes Items 6-10: 2-1/2 & 3 Inch Valves 92-310-2-203 4 Inch Valve 92-310-2-403
(b)	Repair Parts Kit Includes Items 4, 7, 14, 15, & 18: 2-1/2 & 3 Inch Valves 92-310-1-204 4 Inch Valve 92-310-1-404
(c)	Reset Plunger Parts Kit Includes Items 11-18 92-310-1-405
(d)	Reset Knob, Item 11. 92-310-1-406
(e)	Reset Bushing O-Ring, Item 14 92-310-1-407

FIGURE 1 - PART 1 OF 2
MODEL DPV-1 DRY PIPE VALVE
2-1/2, 3, AND 4 INCH (DN65, DN80, DN100) ASSEMBLIES

NO.	DESCRIPTION	QTY.	REP. PART
1	Valve Body	1	NR
2	Air and Water Seat	1	NR
3	Water Seal O-Ring	1	NR
4	Air Seal O-Ring	1	NR

NO.	DESCRIPTION	QTY.	REP. PART
5	Socket Head Cap Screw	8	NR
6	Handhole Cover	1	NR
7	Handhole Cover Gasket	1	(b)

NO.	DESCRIPTION	QTY.	REP. PART
8	Hex Head Cap Screw	6	CH
9	Clapper	1	(a)
10	Clapper Facing	1	(a) or (b)
11	Clapper Facing Retaining Plate	1	(a)
12	Socket Head Cap Screw	9	(a)
13	Clapper Hinge Pin	1	(a)
14	Reset Knob	1	(c) or (d)
15	Reset Spring	1	(c)
16	Reset Bushing	1	(c)
17	Reset Bushing O-Ring	1	(b), (c) or (e)
18	Reset Plunger O-Ring	1	(b) or (c)
19	Reset Plunger	1	(c)
20	Reset Latch Subassembly	1	(c)
21	Dow Corning FS3452 Fluorosilicone Grease, 1.5 g	1	(b) or (c)

NR: Not Replaceable
 CH: Common Hardware

REPLACEMENT PARTS		
NO.	DESCRIPTION	P/N
(a)	Clapper Assembly	
	Includes Items 9-13	92-310-2-603
(b)	Repair Parts Kit	
	Includes Items 7, 10, 17, 18, 21	92-310-1-604
(c)	Reset Plunger Parts Kit	
	Includes Items 14-21	92-310-1-405
(d)	Reset Knob, Item 14	92-310-1-406
(e)	Reset Bushing O-Ring, Item 17	92-310-1-407

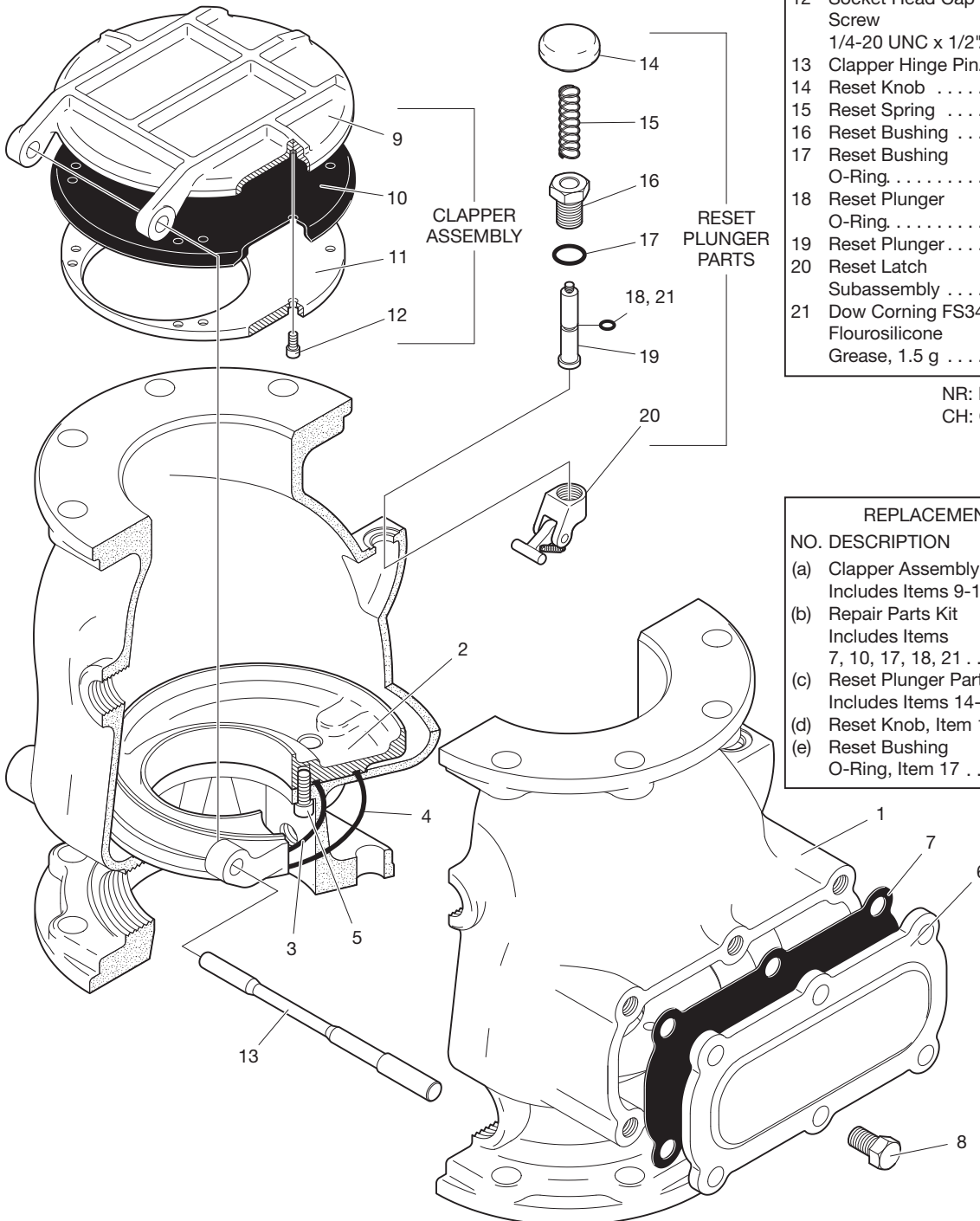
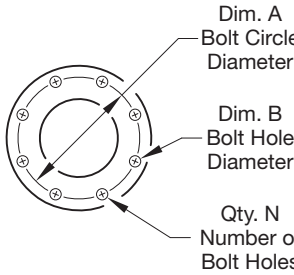

FIGURE 1 - PART 2 OF 2
MODEL DPV-1 DRY PIPE VALVE
6 INCH (DN150) ASSEMBLY

Nominal Valve Size	Flange Drilling Specification											
	Nominal Dimensions in Inches and (mm)											
	ANSI B16.11 ¹ (Class 125)			ISO 7005-2 (PN16) ²			JIS B 2210 (10K)			AS 2129 (Table E)		
	Dim. A	Dim. B	Qty. N	Dim. A	Dim. B	Qty. N	Dim. A	Dim. B	Qty. N	Dim. A	Dim. B	Qty. N
4 Inch (DN100)	7.50 (190,5)	0.75 (19,0)	8	7.09 (180,0)	0.75 (19,0)	8	6.89 (175,0)	0.59 (15,0)	8	7.00 (178,0)	0.71 (18,0)	8
6 Inch (DN150)	9.50 (241,3)	0.88 (22,2)	8	9.45 (240,0)	0.91 (23,0)	8	9.45 (240,0)	0.75 (19,0)	8	9.25 (235,0)	0.87 (22,0)	8



Dim. A
Bolt Circle Diameter

Dim. B
Bolt Hole Diameter

Qty. N
Number of Bolt Holes

1. Drilling same as ANSI B16.5 (Class 150) and ANSI B16.42 (Class 150).
2. Drilling same as BS 4504 Section 3.2 (PN16) and DIN 2532 (PN16).

TABLE A
SELECTION OF FLANGE DRILLING SPECIFICATIONS

Ordering Procedure section and in the “Available End Connection and Sizes” table above.

Trim port connections of valves having flanges drilled to ANSI, AS, or JIS specifications are NPT threaded per ANSI Standard B1.20.1. Trim port connections of valves having flanges drilled to ISO are available either threaded per ISO 7-1 or NPT threaded per ANSI Standard B1.20.1. Valves with NPT threaded ports will readily accept the trim arrangements shown in Parts 2 and 3 of Figures 3, 4, and 5.

Model DPV-1 Valve assemblies are shown in Figure 1. The Body and Hand-hole Cover are ductile iron. The Hand-hole Cover Gasket is neoprene, and the Clapper Facing is EPDM. The Air/Water Seat Ring is brass, the Clapper is bronze or aluminum bronze, and both the Clapper Retaining Plate and Latch are bronze. The Hinge Pin is aluminum bronze, and the fasteners for the Hand-hole Cover are carbon steel.

Valve Trim

Installation dimensions are provided in Figure 6, and Valve Trim and Pre-Trimmed Valve Assemblies are shown in Figures 3, 4, and 5.

The valve trim, ordered separately or as a pre-trimmed valve assembly, forms a part of the laboratory listings and approvals of the DPV-1 Valve and is necessary for the proper operation of the DPV-1 Valve.

Trim packages or pre-trimmed valve assemblies include the following equipment:

- Water Supply Pressure Gauge
- System Air Pressure Gauge
- Air Supply Connections
- Main Drain Valve
- Low Body Drain Valve
- Alarm Test Valve
- Automatic Drain Valve
- Drip Funnel

- Connections For Optional Quick Opening Device (Accelerator)

Pre-trimmed valve assemblies also include the following equipment:

- Model BFV-300 butterfly valve
- Figure 577 grooved coupling
- PS10-2 waterflow alarm switch
- PS40-2 low air pressure alarm switch

Order the above equipment separately when ordering trim packages separately.

Note: When the system pressure is greater than 175 psi (12,1 bar), provision shall be made to replace the standard order 300 psi (20,7 bar) Water Pressure gauge with a separately ordered 600 psi (41,4 bar) Water Pressure Gauge.

Weights

The following are the nominal weights for Pre-Trimmed Valve Assemblies, Semi-Assembled Trim, and DPV-1 Valves without trim.

Pre-Trimmed DPV-1 Valve Assemblies:

- 2-1/2 Inch (DN65) GxG 87lbs (40kg)
- 3 Inch (DN80) GxG..... 90lbs (42kg)
- 4 Inch (DN100) GxG..... 121lbs.(56kg)
- 4 Inch (DN100) FxG..... 135lbs (64kg)
- 4 Inch (DN100) FxF 145bs (69kg)
- 6 Inch (DN150) GxG..... 175lbs (81kg)
- 6 Inch (DN150) FxG..... 195lbs (90kg)
- 6 Inch (DN150) FxF 208lbs (96kg)

Standard Galvanized Semi-Assembled DPV-1 Trim:

- 2-1/2 Inch (DN65)..... 23lbs (11kg)
- 3 Inch (DN80) 23lbs (11kg)
- 4 Inch (DN100) 30lbs (14kg)
- 6 Inch (DN150) 30lbs (14kg)

DPV-1 Valve (Without Trim):

- 2-1/2 Inch (DN65) GxG 37lbs (17kg)
- 3 Inch (DN80) GxG..... 38lbs (18kg)

- 4 Inch (DN100) GxG..... 57lbs (26kg)
- 4 Inch (DN100) FxG..... 67lbs (31kg)
- 4 Inch (DN100) FxF 77lbs (36kg)
- 6 Inch (DN150) GxG..... 95lbs (44kg)
- 6 Inch (DN150) FxG..... 108lbs (50kg)
- 6 Inch (DN150) FxF 121lbs (56kg)

Air Supply

Table B shows the system air pressure requirements as a function of the water supply pressure. The air (or nitrogen) pressure in the sprinkler system is recommended to be automatically maintained by using one of the following pressure maintenance devices, as appropriate:

- Model AMD-1 Air Maintenance Device (pressure reducing type)
- Model AMD-2 Air Maintenance Device (compressor control type)
- Model AMD-3 Nitrogen Maintenance Device (high pressure reducing type)

The Pressure Relief Valve provided with the valve trim is factory set to relieve at a pressure of approximately 45 psi (3,1 bar). If the normal system air pressure is less than or exceeds 40 psi (2,8 bar), then the pressure Relief Valve must be reset to relieve at a pressure that is in accordance with the authority having jurisdiction.

Quick Opening Device

The Model DPV-1 Dry Pipe Valve may optionally be equipped with an electronic or mechanical dry pipe valve accelerator. Select the VIZOR Electronic Dry Pipe Valve Accelerator (4 and 6 inch sizes only) described in Technical Data Sheet TFP1105 or the Model ACC-1 Mechanical Dry Pipe Valve Accelerator (2-1/2 through 6 inch sizes) described in Technical Data Sheet TFP1112.

The VIZOR or the ACC-1 is used to reduce the time to valve actuation following the operation of one or more automatic sprinklers. In some cases the use of a quick opening device such as the VIZOR or the ACC-1 may

Maximum Water Supply Pressure psi	System Air Pressure Range psi
20	10
60	15 - 23
80	20 - 28
100	25 - 33
120	30 - 38
145	35 - 43
165	40 - 48
185	45 - 53
205	50 - 58
225	55 - 63
250	60 - 68

**TABLE B
SYSTEM AIR PRESSURE
REQUIREMENTS**

be required to meet the requirements of the National Fire Protection Association to meet water delivery times.

Operation

The TYCO Model DPV-1 Dry Pipe Valve is a differential type valve that utilizes a substantially lower system (air or nitrogen) pressure than the supply (water) pressure, to maintain the set position shown in Figure 2A. The differential nature of the DPV-1 is based on the area difference between the air seat and the water seat in combination with the ratio of the radial difference from the Hinge Pin to the center of the Water Seat and the Hinge Pin to the center of the Air Seat. The difference is such that 1 psi (0,07 bar) of system air pressure can hold approximately 5.5 psi (0,38 bar) of water supply pressure.

Table B establishes the minimum required system air pressure that includes a safety factor to help prevent false operations that occur due to water supply fluctuations.

The Intermediate Chamber of the DPV-1 is formed by the area between the Air Seat and Water Seat as shown in Figure 2B. The Intermediate Chamber normally remains at atmospheric pressure through the Alarm Port connection and the valve trim to the normally open Automatic Drain Valve (Fig. 3, 4, or 5). Having the Intermediate Chamber, Figure 2B, open to atmosphere is critical to the DPV-1 Valve remaining set, otherwise the full resulting pressure of the system air pressure on top of the Clapper Assembly cannot be realized.

For example, and assuming a water supply pressure of 100 psi (6,9 bar), if the system air pressure is 25 psi (1,7 bar) and there was 15 psi (1,0 bar) pressure trapped in the Intermediate Chamber, the resulting pressure across

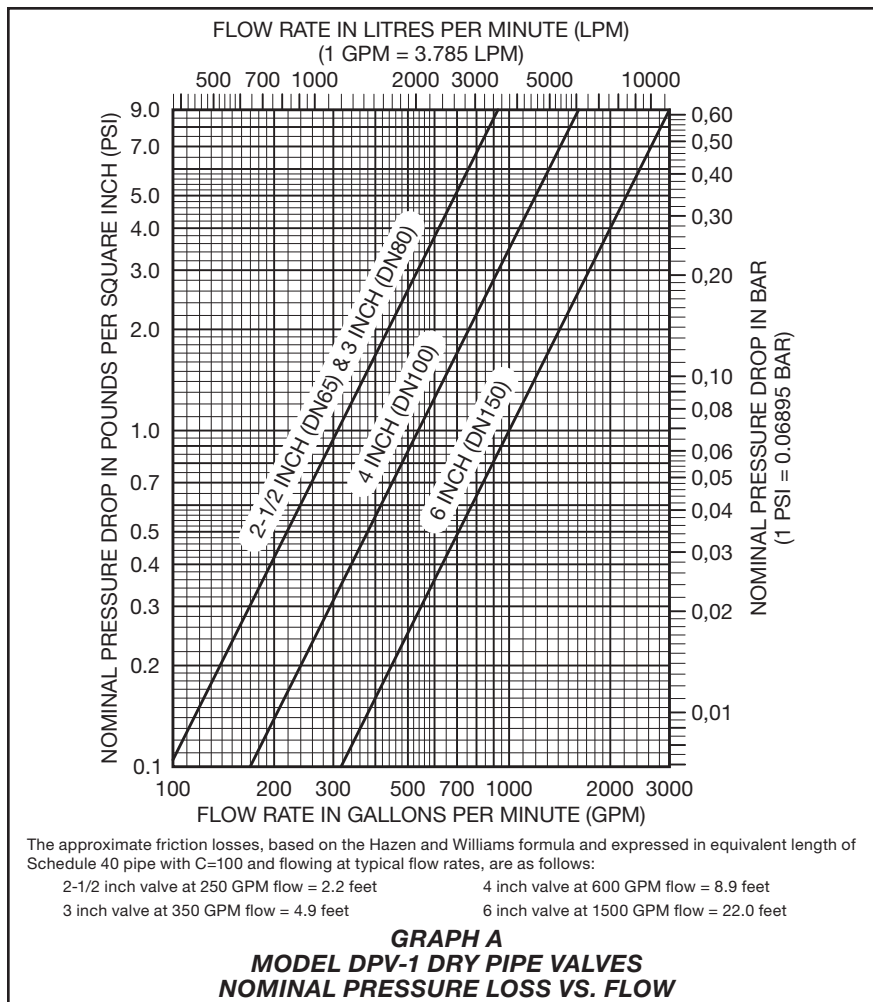

the top of the Clapper would only be 10 psi (0,7 bar). This pressure would be insufficient to hold the Clapper Assembly closed against a water supply pressure of 100 psi (6,9 bar). It is for this reason that the plunger of the Automatic Drain Valve must be depressed during several of the resetting steps, as well as during inspections, making certain that the Automatic Drain Valve is open.

When one or more automatic sprinklers operate in response to a fire, air pressure within the system piping is relieved through the open sprinklers. When the air pressure is sufficiently reduced, the water pressure overcomes the differential holding the Clapper Assembly closed and the Clapper Assembly swings clear of the water seat, as shown in Figure 2C, This action permits water flow into the system piping and subsequently to be discharged from any open sprinklers. Also, with the Clapper Assembly open, the intermediate chamber is pressurized and water flows through the alarm port (Ref. Figure 2B) at the rear of the DPV-1 Valve to actuate system water flow alarms. The flow from the alarm

port is also sufficient to close the otherwise normally open Automatic Drain Valve in the valve trim.

After a valve actuation and upon subsequent closing of a system main control valve to stop water flow, the Clapper Assembly will latch open as shown in Figure 3D. Latching open of the DPV-1 will permit complete draining of the system (including any loose scale) through the main drain port.

During the valve resetting procedure and after the system is completely drained, the external reset knob can be easily depressed to externally unlatch the Clapper Assembly, as shown in Figure 2E. As such, the Clapper Assembly is returned to its normal set position to facilitate setting of the dry pipe sprinkler system, without having to remove the Handhole Cover.

Installation

General Instructions

Proper operation of the Model DPV-1 Dry Pipe Valve depends upon its trim being installed in accordance with the instructions given in this Technical Data Sheet. Failure to follow the appropriate trim diagram may prevent the DPV-1 Valve from functioning properly, as well as void listings, approvals, and the manufacturer warranties.

Failure to latch open the Clapper Assembly prior to a system hydrostatic test may result in damage to the Clapper Assembly.

The DPV-1 Valve must be installed in a readily visible and accessible location.

The DPV-1 Valve and associated trim must be maintained at a minimum temperature of 40°F (4°C).

Heat tracing of the DPV-1 Valve or its associated trim is not permitted. Heat tracing can result in the formation of hardened mineral deposits that are capable of preventing proper operation.

The Model DPV-1 Dry Pipe Valve is to be installed in accordance with the following criteria:

- All nipples, fittings, and devices must be clean and free of scale and burrs before installation. Use pipe thread sealant sparingly on male pipe threads only.
- The DPV-1 Valve must be trimmed in accordance with Figures 3, 4, or 5, as applicable. If the DPV-1 is to

be equipped with a Dry Pipe Valve Accelerator, refer to the Technical Data Sheet TFP1105 for the VIZOR Electronic Dry Pipe Valve Accelerator or TFP1112 for the Model ACC-1 Mechanical Dry Pipe Valve Accelerator.

- Care must be taken to make sure that check valves, strainers, globe valves, etc. are installed with the flow arrows in the proper direction.
- Drain tubing to the drip funnel must be installed with smooth bends that will not restrict flow.
- The main drain and drip funnel drain may be interconnected provided a check valve is located at least 12 inches (300 mm) below the drip funnel. The Low Body Drain Valve (Figure 3, 4, or 5) may be piped so as to discharge into the Drip Funnel or to a separate drain.
- Suitable provision must be made for disposal of drain water. Drainage water must be directed such that it will not cause accidental damage to property or danger to persons.
- Unused pressure alarm switch and/or water motor alarm connections must be plugged.
- The Pressure Relief Valve provided with the Valve Trim is factory set to relieve at a pressure of approximately 45 psi (3,1 bar), which can typically be used for a maximum normal system air pressure of 40 psi (2,8 bar). The Pressure Relief Valve may be reset to a lower or higher pressure;

however, it must be reset to relieve at a pressure which is in accordance with the requirements of the authority having jurisdiction.

To reset the Pressure Relief Valve, first loosen the jam nut and then adjust the cap accordingly — clockwise for a higher pressure setting or counter-clockwise for a lower pressure setting. After verifying the desired pressure setting, tighten the jam nut.

- Installation of an Air Maintenance Device, as described in the Technical Data Section, is recommended.
- An Inspector's Test Connection as required By NFPA 13 must be provided on the system piping at the most remote location from the Model DPV-1 Valve.
- Conduit and electrical connections are to be made in accordance with the requirements of the authority having jurisdiction and/or the National Electric Code.
- Before a system hydrostatic test is performed in accordance with NFPA 13 system acceptance test requirements, the Clapper Assembly is to be manually latched open (Ref. Figure 2D); the Automatic Drain Valve (Figure 3, 4, or 5) is to be temporarily replaced with a 1/2 inch NPT plug, the 3/32 inch Vent Fitting (Item 13, Figure 3; Item 15, Figure 4; or Item 15, Figure 5) is to be temporarily replaced with a 1/4 inch NPT plug, and the Handhole Cover Bolts are to be tightened using a cross-draw sequence.

Valve Setting Procedure

Steps 1 through 11 are to be performed when initially setting the Model DPV-1 Dry Pipe Valve; after an operational test of the fire protection system; or, after system operation due to a fire.

NOTES: If the DPV-1 is equipped with a Dry Pipe Valve Accelerator, refer to its resetting instructions before resetting the DPV-1. Refer to TFP1105 for the VIZOR or TFP1112 for the ACC-1.

Based on the instructions provided, reset the Accelerator at the appropriate time during the resetting of the DPV-1.

Unless otherwise noted, refer to Figure 3, 4, or 5 to identify functional trim components.

Step 1. Close the Main Control Valve, and close the Air Supply Control Valve. If the DPV-1 is equipped with a Dry Pipe Valve Accelerator, remove the Dry Pipe Valve Accelerator from service in accordance with its Technical Data Sheet (Refer to TFP1105 for the VIZOR or TFP1112 for the ACC-1).

Step 2. Open the Main Drain Valve and all auxiliary drains in the system. Close the auxiliary drain valves after water ceases to discharge. Leave the Main Drain Valve open.

Step 3. Depress the plunger of the Automatic Drain Valve to verify that it is open and that the DPV-1 Valve is completely drained.

Step 4. Open the Optional Alarm Control Valve, as applicable, if it was closed to silence local alarms.

Step 5. As necessary, replace all sprinklers that have operated. Replacement sprinklers must be of the same type and temperature rating as those which have operated.

NOTICE

In order to prevent the possibility of a subsequent operation of an over-heated solder type sprinkler, any solder type sprinklers which were possibly exposed to a temperature greater than their maximum rated ambient must be replaced.

Step 6. Push down on the Reset Knob (Figure 2E) to allow the Clapper Assembly to re-seat.

Step 7. Pressurize the system with air (or nitrogen) to 10 psi (0,7 bar), and then individually open all auxiliary drain valves in the system piping to drain any remaining water in trapped sections. Close each drain valve as soon as water ceases to discharge.

Also partially open the Low Body Drain Valve to assure that the riser is completely drained. Close the Low Body Drain Valve as soon as water ceases to discharge.

Step 8. Refer to Table B and then restore the system to the normal system air pressure as necessary to hold the DPV-1 Valve closed.

Step 9. Depress the plunger on the Automatic Drain Valve to make sure it is open and that there is no air discharging.

The absence of air discharging from the Automatic Drain Valve is an indication of a properly set air seat within the

DPV-1 Valve. If air is discharging, refer to the Care and Maintenance section under Automatic Drain Valve Inspection to determine/correct the cause of the leakage problem.

Step 10. Partially open the Main Control Valve. Slowly close the Main Drain Valve as soon as water discharges from the drain connection.

Depress the plunger on the Automatic Drain Valve to make sure that it is open and that there is no water discharging. The absence of water discharging from the Automatic Drain Valve is an indication of a properly set water seat within the DPV-1 Valve. If water is discharging, refer to the Care and Maintenance section under the Automatic Drain Valve Inspection to determine/correct the cause of the leakage problem.

If there are no leaks, the DPV-1 Valve is ready to be placed in service and the Main Control Valve must then be fully opened.

Note: After setting a fire protection system, notify the proper authorities and advise those responsible for monitoring proprietary and/or central station alarms.

Step 11. Once a week after a valve is reset following an operational test or system operation, the Low Body Drain Valve (and any low point drain valves) should be partially opened (and then subsequently closed) to relieve drain-back water. Continue this procedure until drain-back water is no longer present.

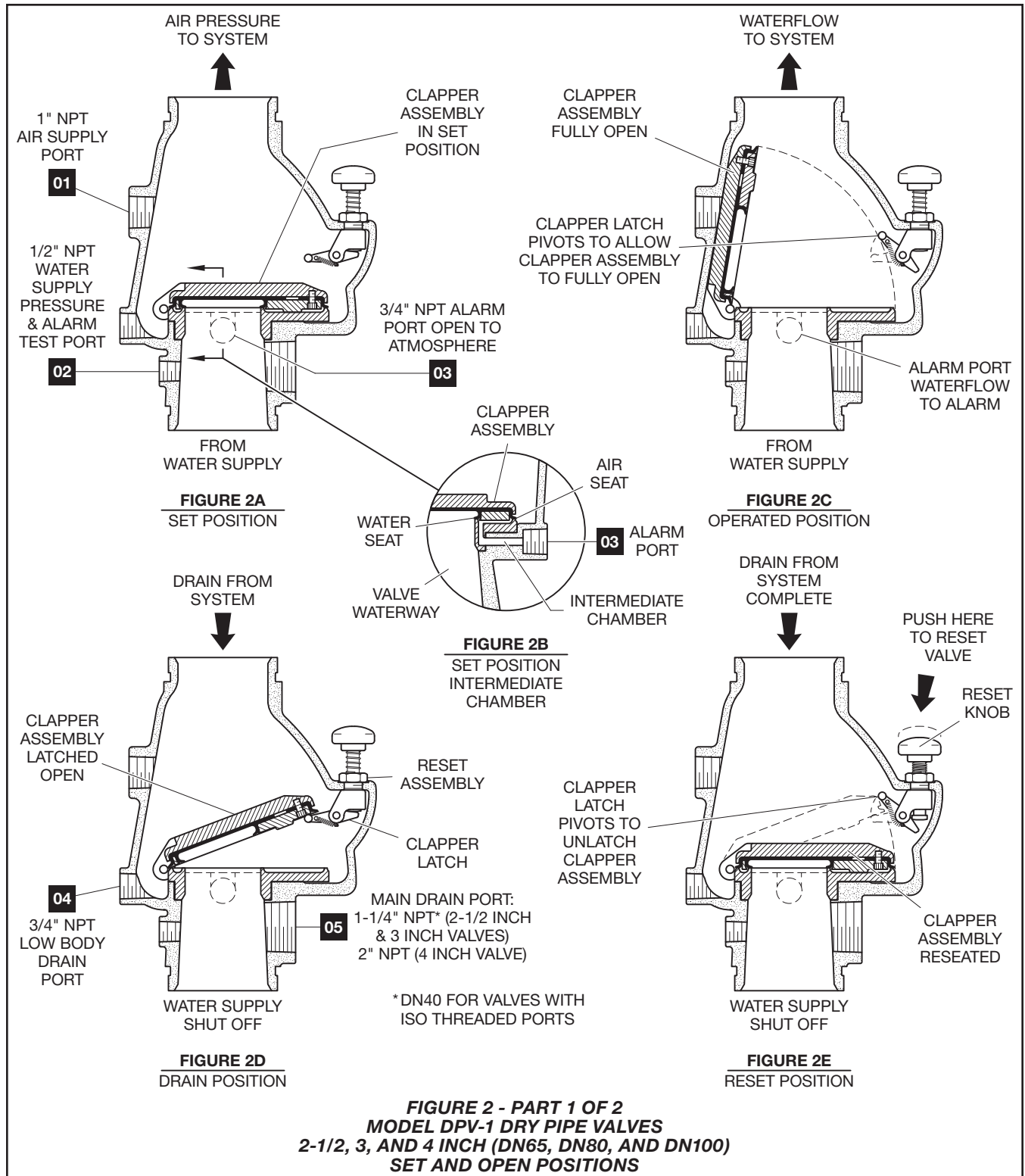

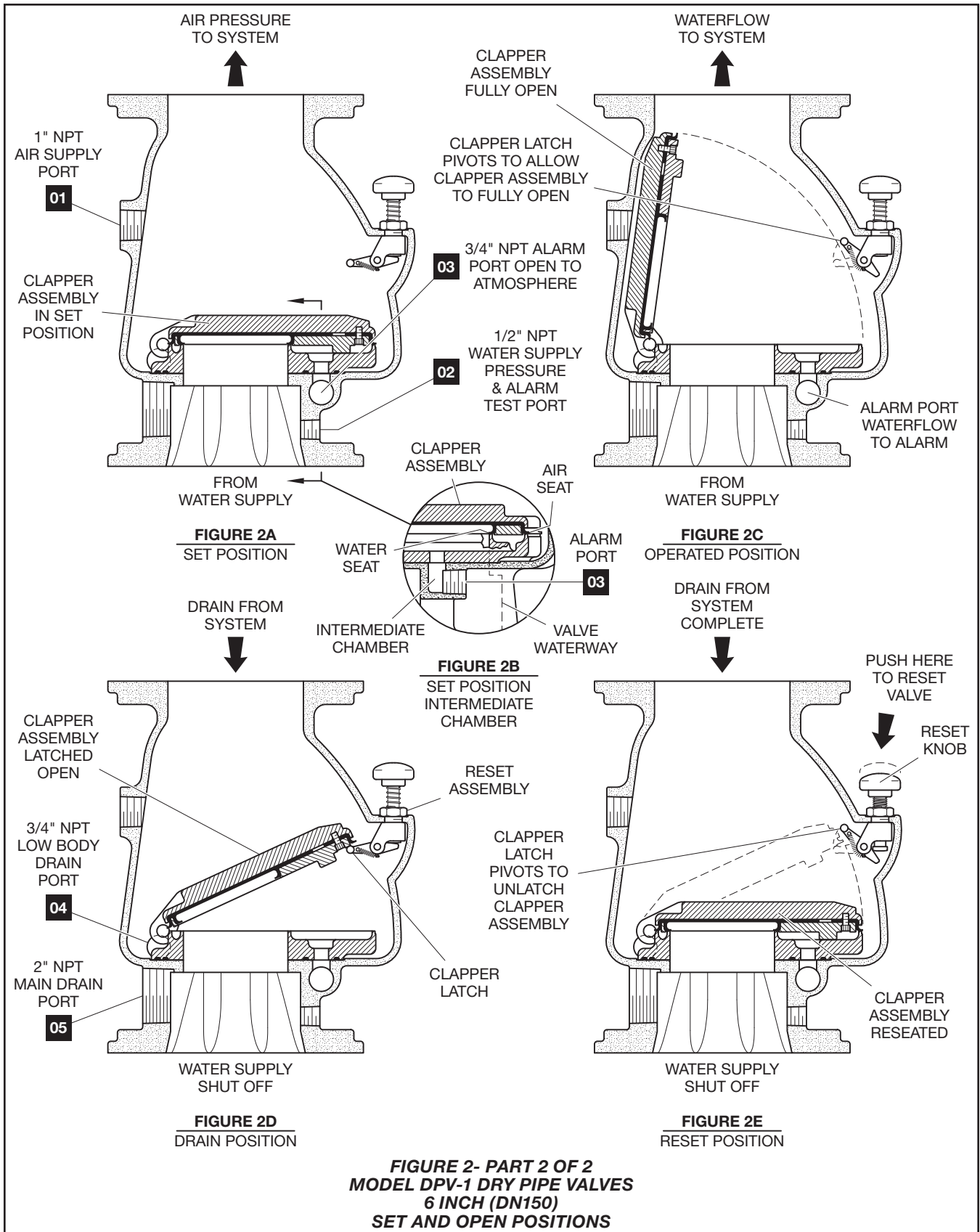

NOTES:

1. SEE FIGURE 3 PART 3 FOR TRIM ARRANGEMENT WITH BILL OF MATERIALS AND COMPONENT PART NUMBERS.
2. TRIM SHOWN FULLY ASSEMBLED; COMPONENTS SUCH AS GAUGES AND SWITCHES MAY REQUIRE ASSEMBLY IN TRIM AT INSTALLATION.

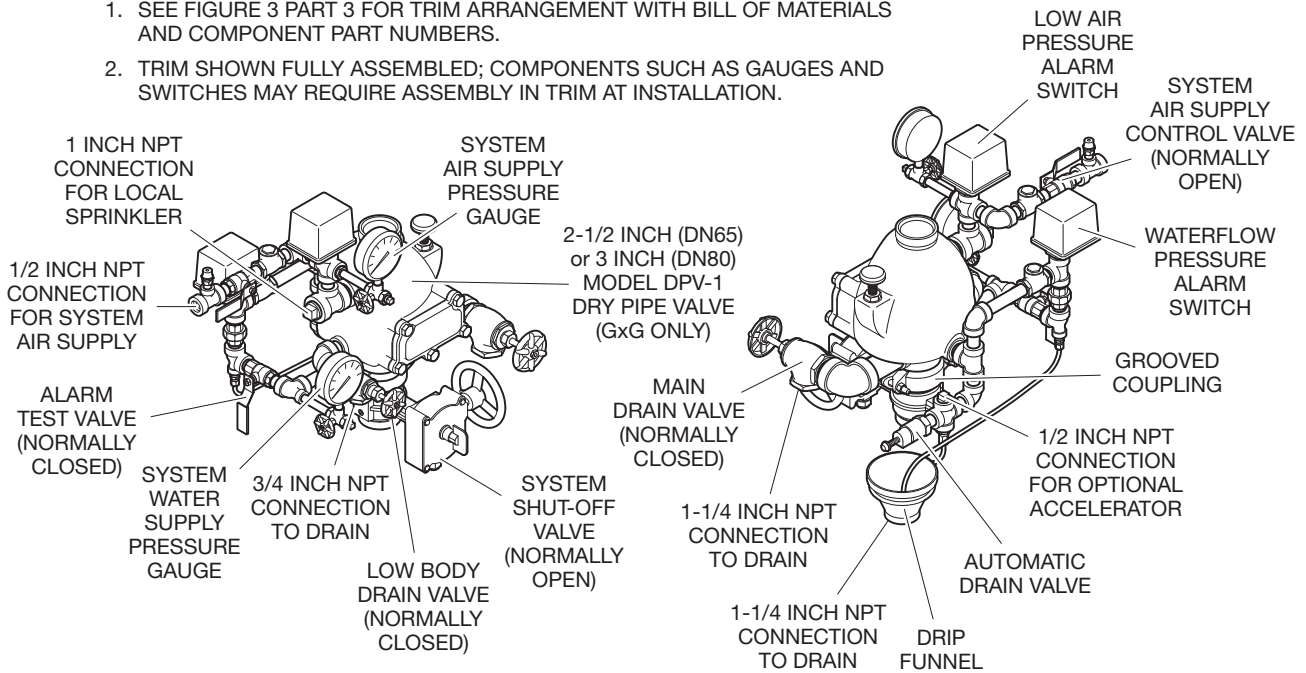
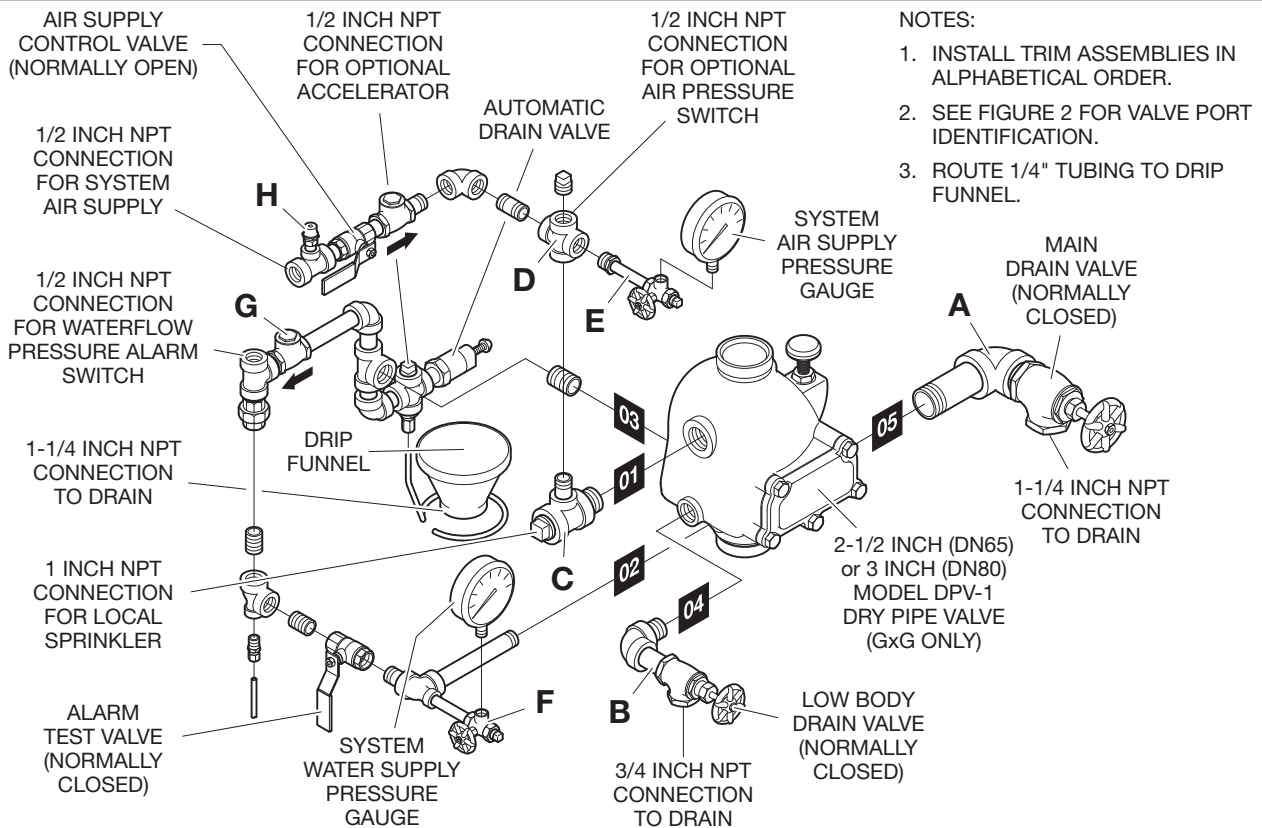

FIGURE 3 - PART 1 OF 3
2-1/2 AND 3 INCH (DN65 AND DN80) MODEL DPV-1 DRY PIPE VALVE
PRE-TRIMMED ASSEMBLY



NOTES:

1. INSTALL TRIM ASSEMBLIES IN ALPHABETICAL ORDER.
2. SEE FIGURE 2 FOR VALVE PORT IDENTIFICATION.
3. ROUTE 1/4" TUBING TO DRIP FUNNEL.

FIGURE 3 - PART 2 OF 3
2-1/2 AND 3 INCH (DN65 AND DN80) MODEL DPV-1 DRY PIPE VALVE
EXPLODED ARRANGEMENT OF SEMI-ASSEMBLED TRIM

NO.	DESCRIPTION	QTY	P/N
1	250 psi/ 1750 kPa Air Pressure Gauge	1	92-343-1-012
2	300 psi/ 2000 kPa Water Pressure Gauge	1	92-343-1-005
3	1/4" Gauge Test Valve	2	46-005-1-002
4	Model AD-1 Automatic Drain Valve	1	52-793-2-004
5	1/4" Pressure Relief Valve	1	92-343-1-020
6	1/2" Ball Valve	2	46-050-1-004
7	3/4" Angle Valve	1	46-048-1-005
8	1-1/4" Angle Valve	1	46-048-1-007
9	1/2" Swing Check Valve	2	46-049-1-004
10	Drip Funnel Connector	1	92-211-1-005
11	Drip Funnel Bracket	1	92-211-1-003
12	Drip Funnel	1	92-343-1-007

NO.	DESCRIPTION	QTY	P/N
13	3/32" Vent Fitting	1	92-032-1-002
14	1/4" Tube, 18" Long	1	CH
15	1/4" Plug	2	CH
16	1/2" Plug	2	CH
17	1" Plug	1	CH
18	1/2" Union	1	CH
19	1/2" x 1/4" Reducing Bushing	1	CH
20	1/2" 90° Elbow	3	CH
21	3/4" 90° Elbow	1	CH
22	1-1/4" 90° Elbow	1	CH
23	1/2" Cross	2	CH
24	1/2" x 1/2" x 1/4" Reducing Tee	1	CH
25	1/2" Tee	1	CH
26	1/2" x 1/4" x 1/2" Reducing Tee	2	CH
27	1/2" x 1/2" x 3/4" Reducing Tee	1	CH

NO.	DESCRIPTION	QTY	P/N
28	1" x 1" x 1/2" Reducing Tee	1	CH
29	Not Used		
PIPE NIPPLES:			
30	1/4" x 3"	2	CH
31	1/2" x Close	4	CH
32	1/2" x 1-1/2"	8	CH
33	1/2" x 2"	1	CH
34	1/2" x 4-1/2"	1	CH
35	1/2" x 6"	1	CH
36	3/4" x Close	1	CH
37	3/4" x 1-1/2"	1	CH
38	3/4" x 2-1/2"	1	CH
39	1" x Close	1	CH
40	1-1/4" x Close	1	CH
41	1-1/4" x 4"	1	CH

COMPONENTS INCLUDED ONLY IN PRE-TRIMMED VALVE ASSEMBLIES:

42	Model BFV-300 Butterfly Valve, 2-1/2" (DN65)	1	59300G025WS
	3" (DN80)	1	59300G030WS
43	Figure 577 Coupling, 2-1/2" (DN65)	1	57725ACP
	3" (DN80)	1	57730ACP
44	Waterflow Pressure Alarm Switch, Model PS10-2.	1	25710
45	Low Air Pressure Alarm Switch, Model PS40-2.	1	25730

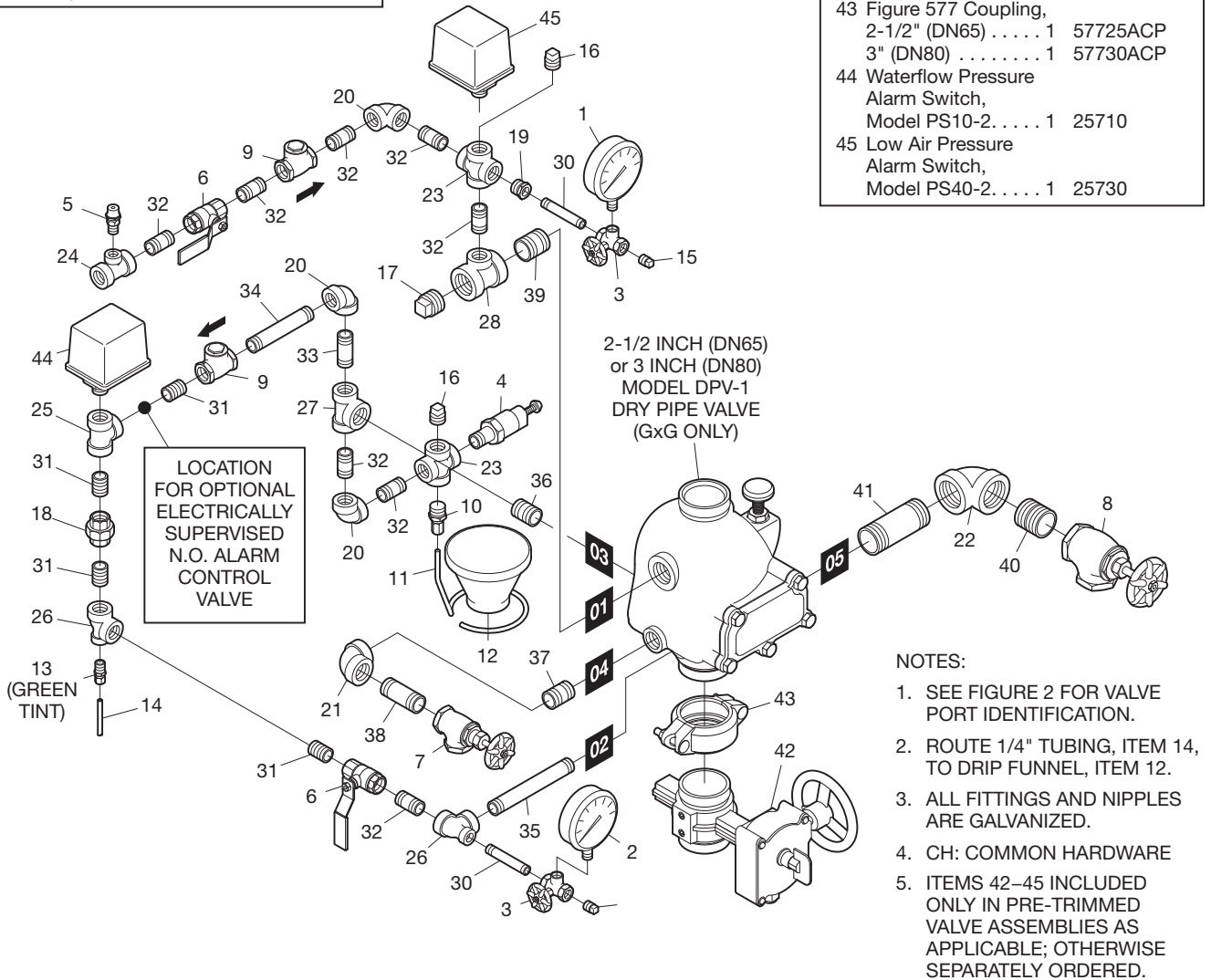

FIGURE 3 - PART 3 OF 3
2-1/2 AND 3 INCH (DN65 AND DN80) MODEL DPV-1 DRY PIPE VALVE
EXPLODED ARRANGEMENT OF VALVE TRIM

1. SEE FIGURE 4 PART 3 FOR TRIM ARRANGEMENT WITH BILL OF MATERIALS AND COMPONENT PART NUMBERS.
2. TRIM SHOWN FULLY ASSEMBLED; COMPONENTS SUCH AS GAUGES AND SWITCHES MAY REQUIRE ASSEMBLY IN TRIM AT INSTALLATION.

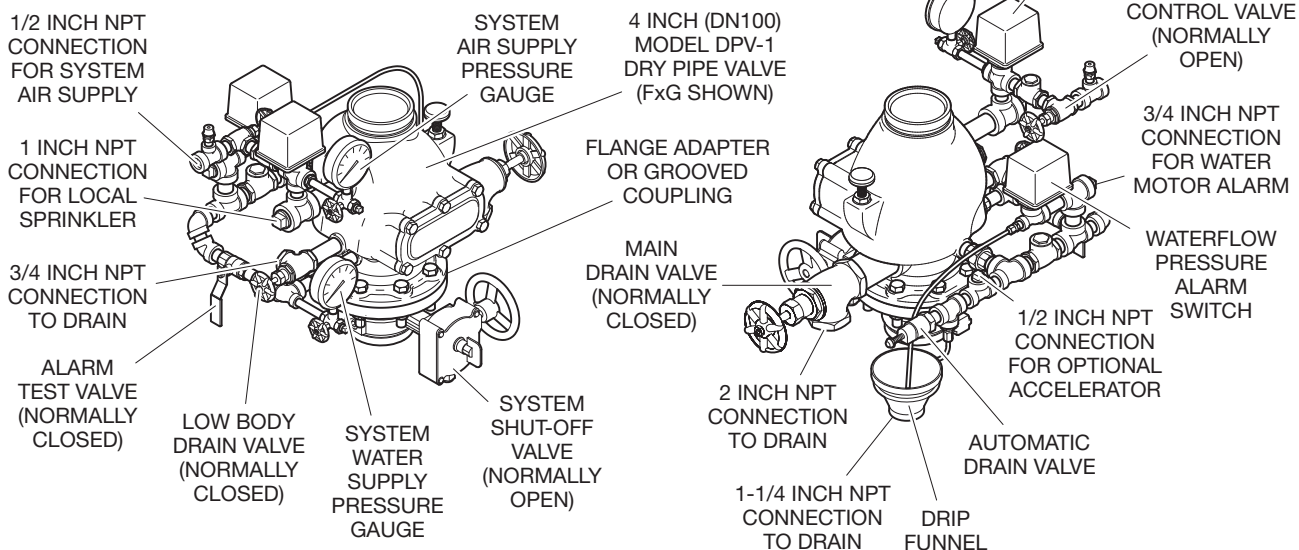

FIGURE 4 - PART 1 OF 3
4 INCH (DN100) MODEL DPV-1 DRY PIPE VALVE
PRE-TRIMMED ASSEMBLY

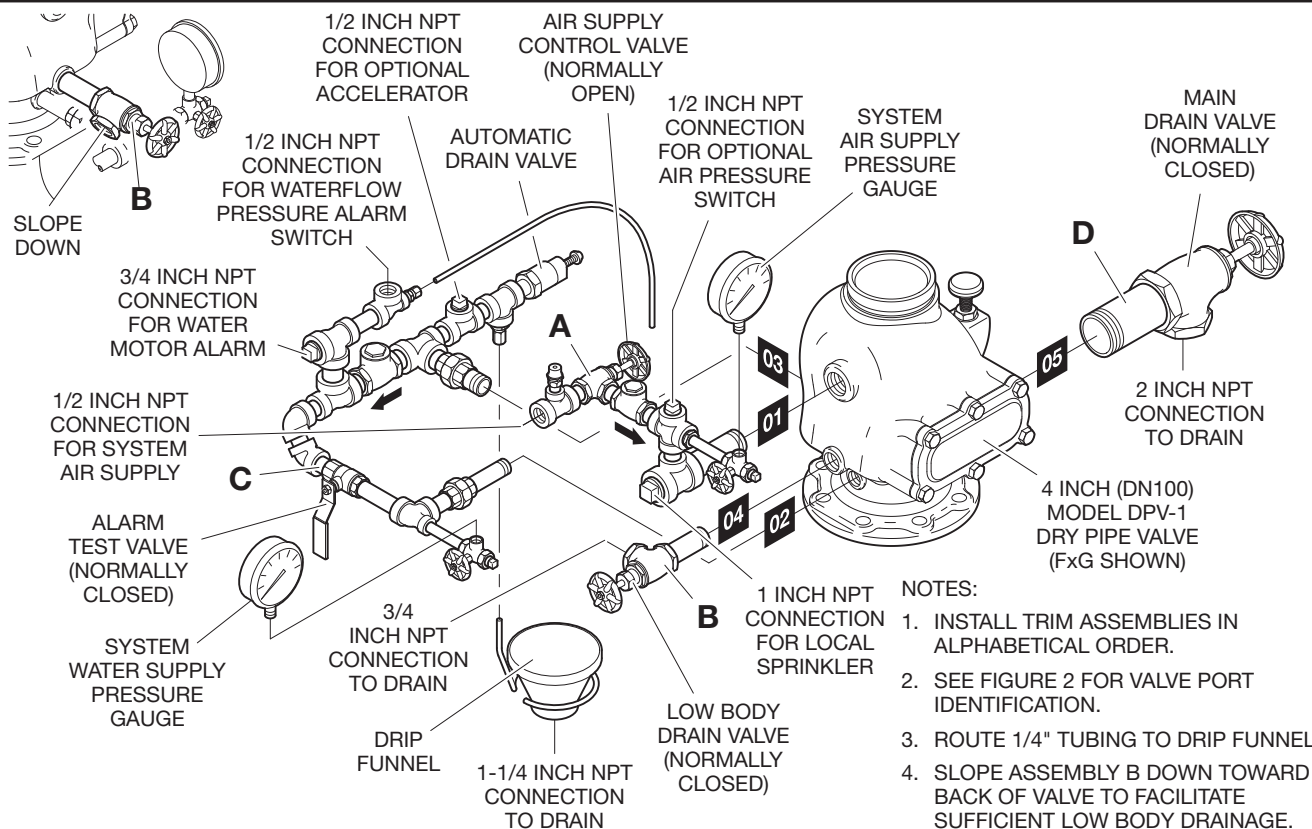
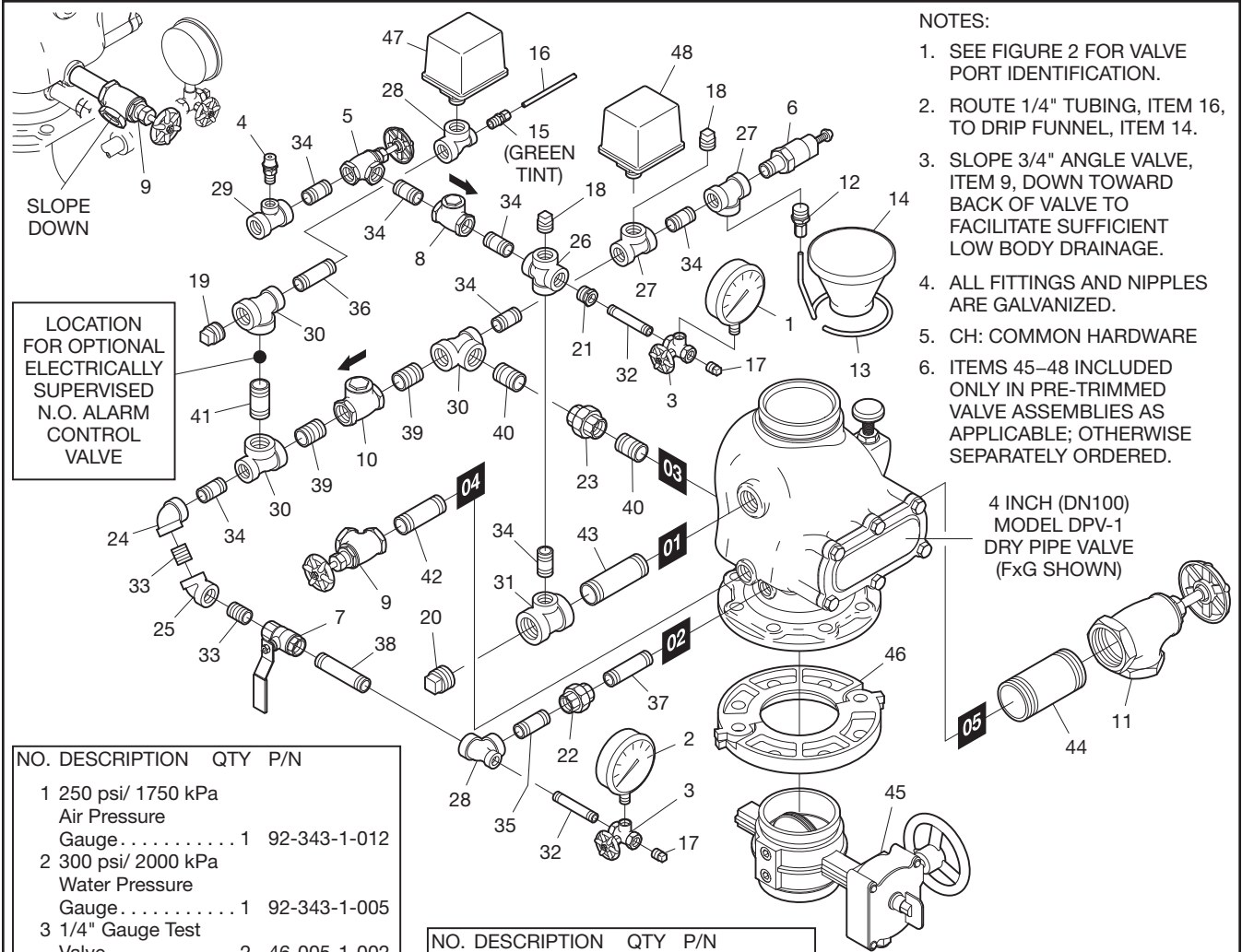

FIGURE 4 - PART 2 OF 3
4 INCH (DN100) MODEL DPV-1 DRY PIPE VALVE
EXPLODED ARRANGEMENT OF SEMI-ASSEMBLED TRIM

- NOTES:**
1. INSTALL TRIM ASSEMBLIES IN ALPHABETICAL ORDER.
 2. SEE FIGURE 2 FOR VALVE PORT IDENTIFICATION.
 3. ROUTE 1/4" TUBING TO DRIP FUNNEL.
 4. SLOPE ASSEMBLY B DOWN TOWARD BACK OF VALVE TO FACILITATE SUFFICIENT LOW BODY DRAINAGE.



- NOTES:**
1. SEE FIGURE 2 FOR VALVE PORT IDENTIFICATION.
 2. ROUTE 1/4" TUBING, ITEM 16, TO DRIP FUNNEL, ITEM 14.
 3. SLOPE 3/4" ANGLE VALVE, ITEM 9, DOWN TOWARD BACK OF VALVE TO FACILITATE SUFFICIENT LOW BODY DRAINAGE.
 4. ALL FITTINGS AND NIPPLES ARE GALVANIZED.
 5. CH: COMMON HARDWARE
 6. ITEMS 45-48 INCLUDED ONLY IN PRE-TRIMMED VALVE ASSEMBLIES AS APPLICABLE; OTHERWISE SEPARATELY ORDERED.

NO.	DESCRIPTION	QTY	P/N
1	250 psi/ 1750 kPa Air Pressure Gauge	1	92-343-1-012
2	300 psi/ 2000 kPa Water Pressure Gauge	1	92-343-1-005
3	1/4" Gauge Test Valve	2	46-005-1-002
4	1/4" Pressure Relief Valve	1	92-343-1-020
5	1/2" Angle Valve	1	46-048-1-004
6	Model AD-1 Automatic Drain Valve	1	52-793-2-004
7	1/2" Ball Valve	1	46-050-1-004
8	1/2" Swing Check Valve	1	46-049-1-004
9	3/4" Angle Valve	1	46-048-1-005
10	3/4" Swing Check Valve	1	46-049-1-005
11	2" Angle Valve	1	46-048-1-009
12	Drip Funnel Connector	1	92-211-1-005
13	Drip Funnel Bracket	1	92-211-1-003
14	Drip Funnel	1	92-343-1-007
15	3/32" Vent Fitting	1	92-032-1-002
16	1/4" Tube, 24" Long	1	CH
17	1/4" Plug	2	CH
18	1/2" Plug	2	CH
19	3/4" Plug	1	CH
20	1" Plug	1	CH

NO.	DESCRIPTION	QTY	P/N
21	1/2" x 1/4" Reducing Bushing	1	CH
22	1/2" Union	1	CH
23	3/4" Union	1	CH
24	1/2" 90° Elbow	1	CH
25	1/2" 45° Elbow	1	CH
26	1/2" Cross	1	CH
27	1/2" Tee	2	CH
28	1/2" x 1/4" x 1/2" Reducing Tee	2	CH
29	1/2" x 1/2" x 1/4" Reducing Tee	1	CH
30	3/4" x 1/2" x 3/4" Reducing Tee	3	CH
31	1" x 1" x 1/2" Reducing Tee	1	CH
PIPE NIPPLES:			
32	1/4" x 3"	2	CH
33	1/2" x Close	2	CH
34	1/2" x 1-1/2"	7	CH
35	1/2" x 2"	1	CH
36	1/2" x 2-1/2"	1	CH
37	1/2" x 3"	1	CH
38	1/2" x 3-1/2"	1	CH
39	3/4" x Close	2	CH
40	3/4" x 1-1/2"	2	CH

NO.	DESCRIPTION	QTY	P/N
41	3/4" x 2"	1	CH
42	3/4" x 3"	1	CH
43	1" x 4"	1	CH
44	2" x 4-1/2"	1	CH
COMPONENTS INCLUDED ONLY IN PRE-TRIMMED VALVE ASSEMBLIES:			
45	Model BFV-300 Butterfly Valve, 4" (DN100)	1	59300G040WS
46	Butterfly Valve Assembly Component: GxG DPV-1 Valves, Figure 577 Coupling, 4" (DN100)	1	57740ACP
	FxF, FxG DPV-1 Valves, Figure 71 Flange Adapter, 4" (DN100)	1	7140S
47	Waterflow Pressure Alarm Switch, Model PS10-2	1	25710
48	Low Air Pressure Alarm Switch, Model PS40-2	1	25730

FIGURE 4 - PART 3 OF 3
4 INCH (DN100) MODEL DPV-1 DRY PIPE VALVE
EXPLODED ARRANGEMENT OF VALVE TRIM

NOTES:

1. SEE FIGURE 5 PART 3 FOR TRIM ARRANGEMENT WITH BILL OF MATERIALS AND COMPONENT PART NUMBERS.
2. TRIM SHOWN FULLY ASSEMBLED; COMPONENTS SUCH AS GAUGES AND SWITCHES MAY REQUIRE ASSEMBLY IN TRIM AT INSTALLATION.

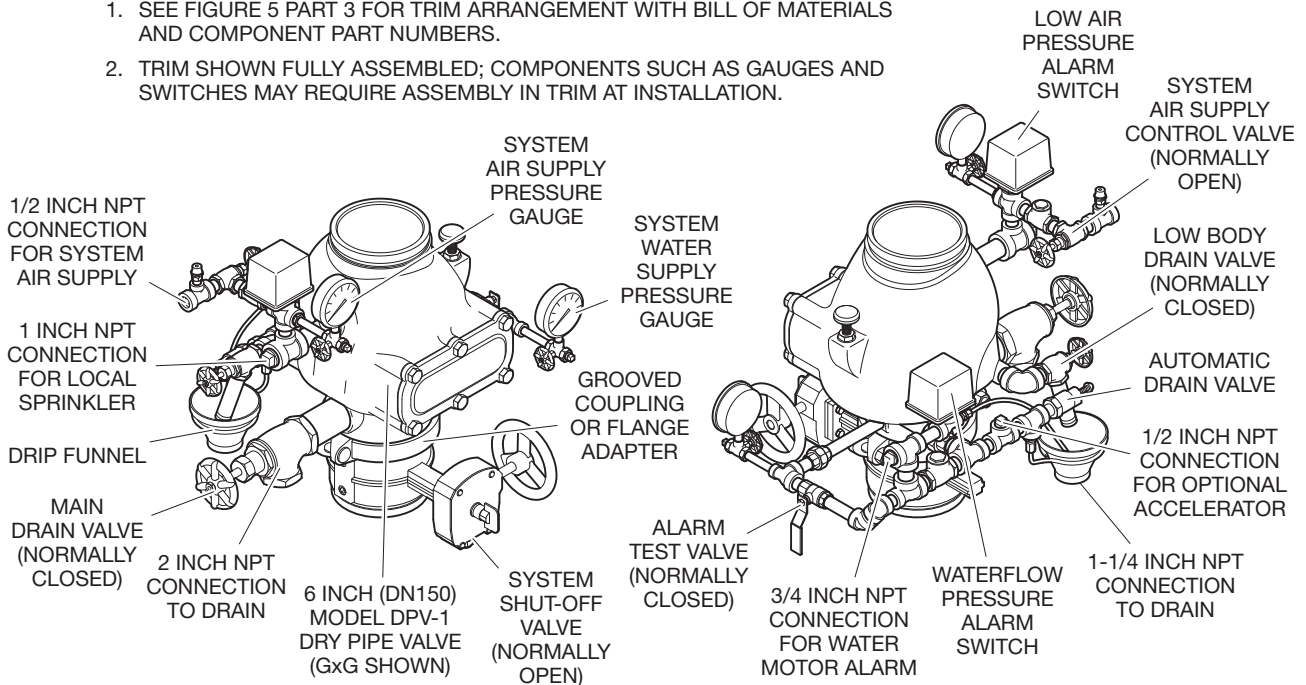
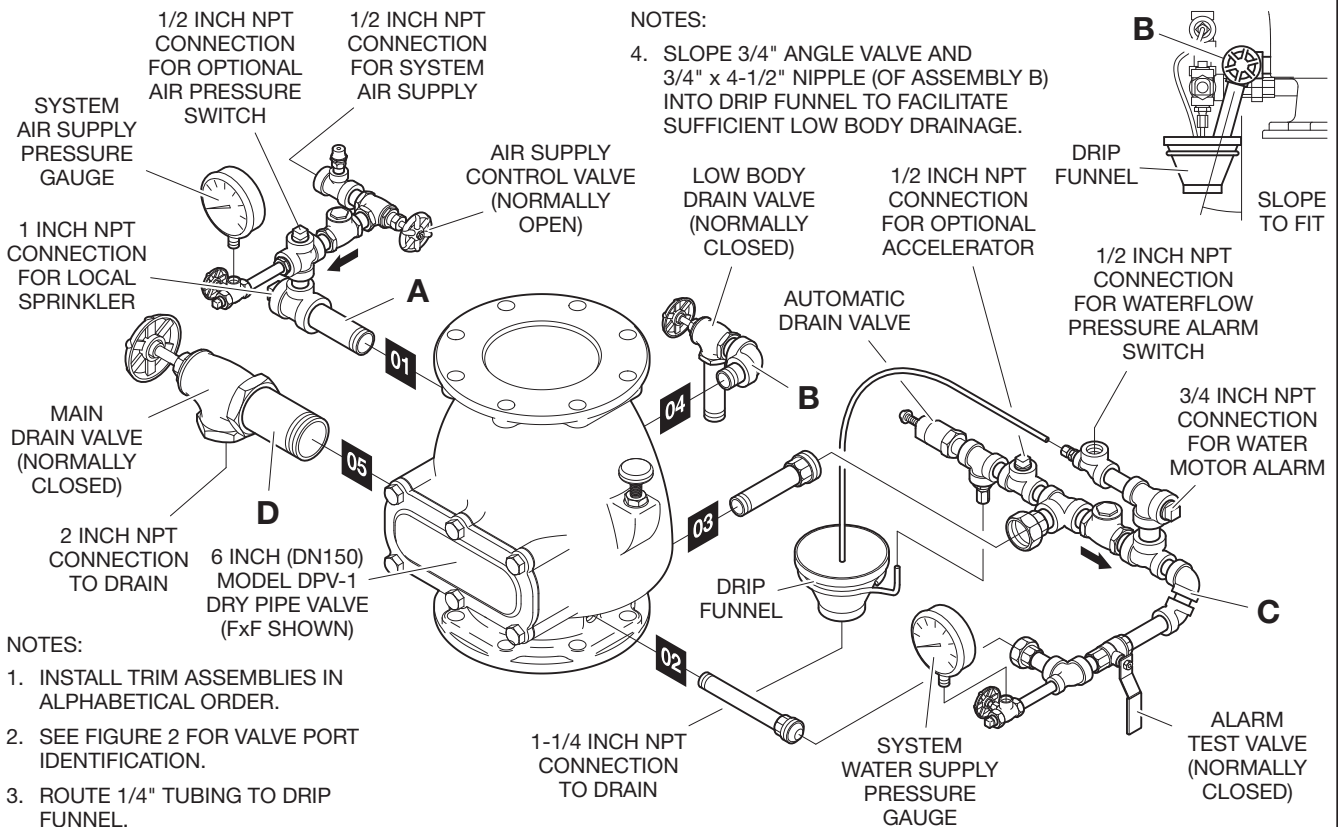

FIGURE 5 - PART 1 OF 3
6 INCH (DN150) MODEL DPV-1 DRY PIPE VALVE
PRE-TRIMMED ASSEMBLY

NOTES:

4. SLOPE 3/4" ANGLE VALVE AND 3/4" x 4-1/2" NIPPLE (OF ASSEMBLY B) INTO DRIP FUNNEL TO FACILITATE SUFFICIENT LOW BODY DRAINAGE.



NOTES:

1. INSTALL TRIM ASSEMBLIES IN ALPHABETICAL ORDER.
2. SEE FIGURE 2 FOR VALVE PORT IDENTIFICATION.
3. ROUTE 1/4" TUBING TO DRIP FUNNEL.

FIGURE 5 - PART 2 OF 3
6 INCH (DN150) MODEL DPV-1 DRY PIPE VALVE
EXPLODED ARRANGEMENT OF SEMI-ASSEMBLED TRIM

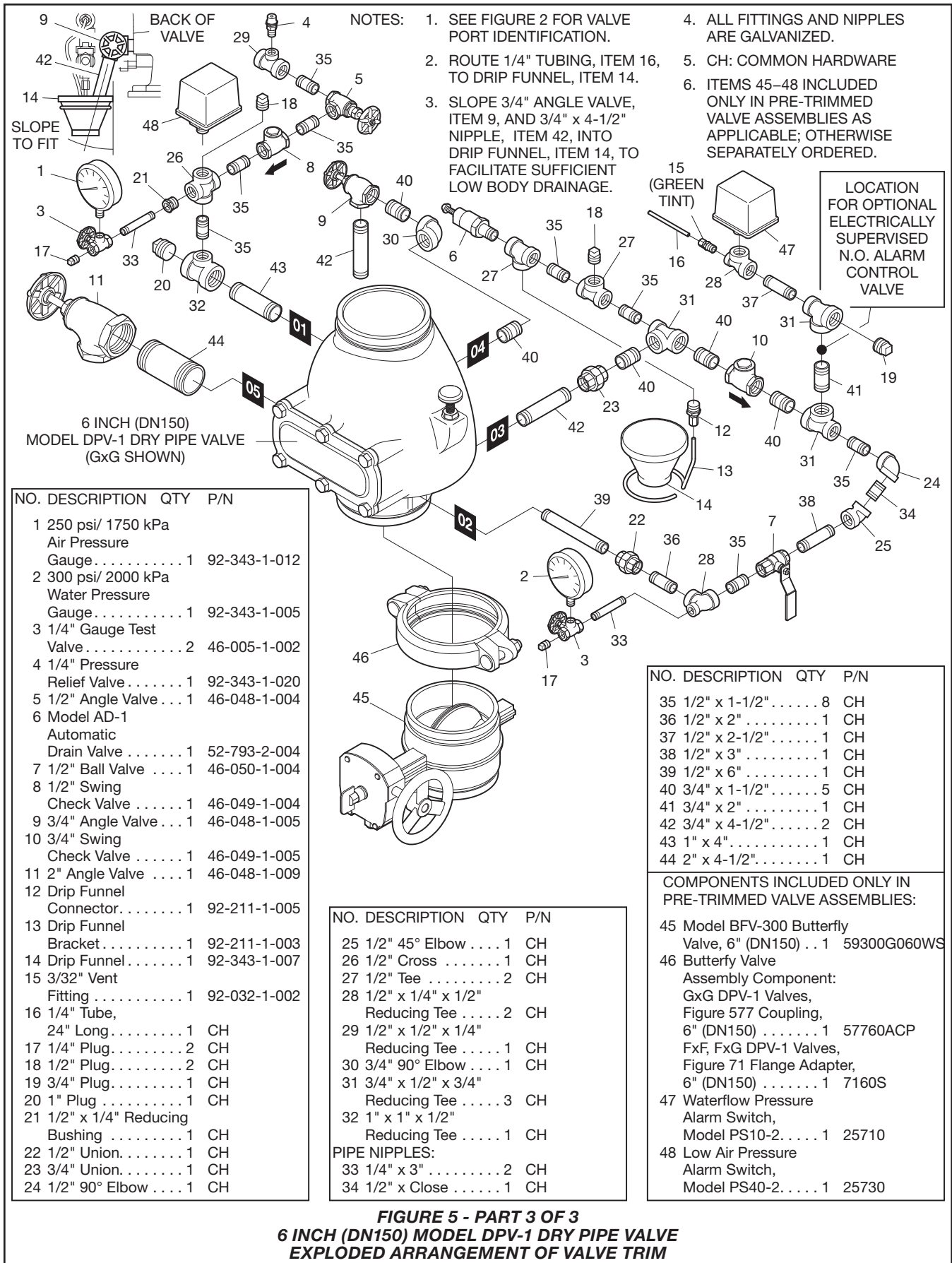

**FIGURE 5 - PART 3 OF 3
6 INCH (DN150) MODEL DPV-1 DRY PIPE VALVE
EXPLODED ARRANGEMENT OF VALVE TRIM**

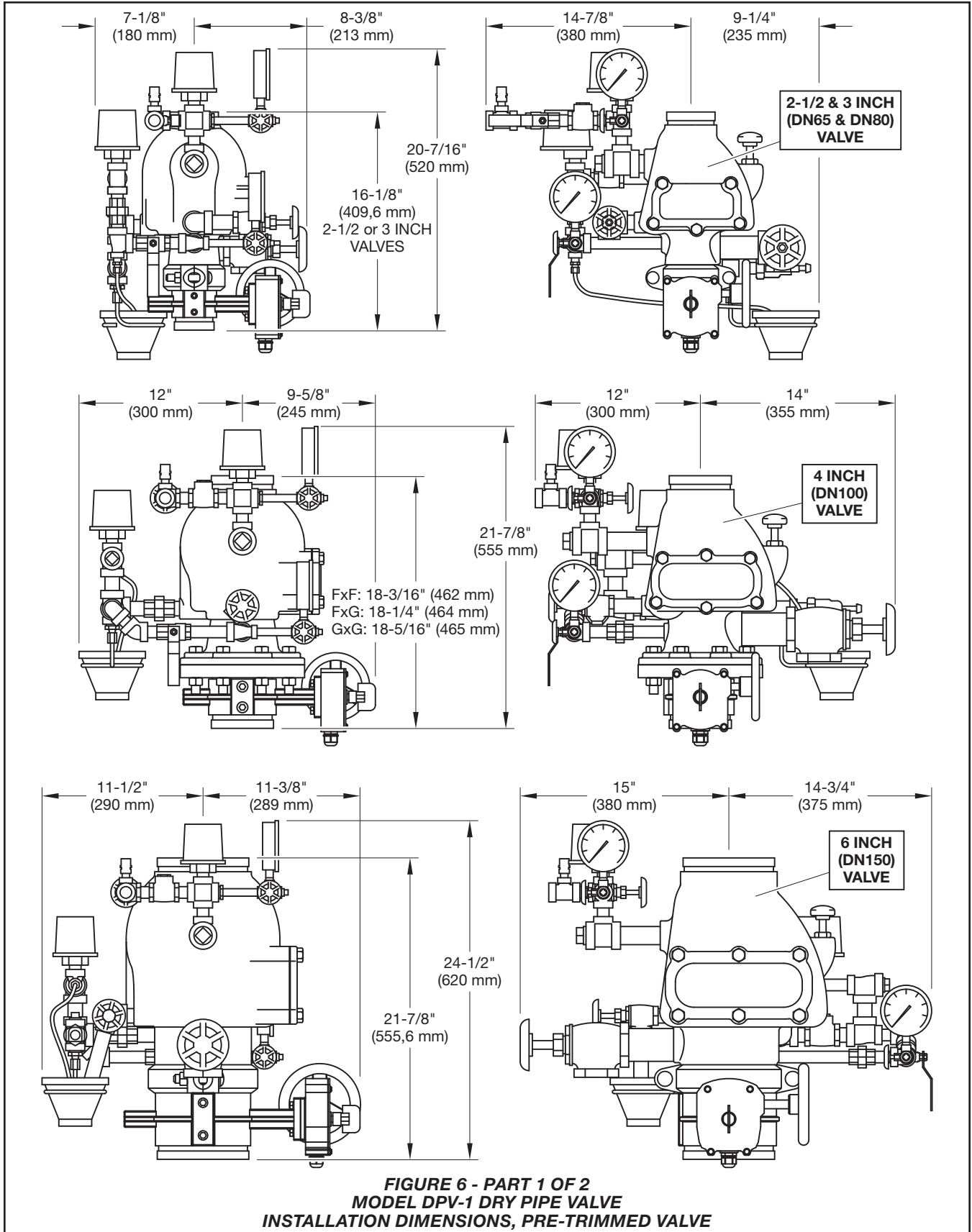

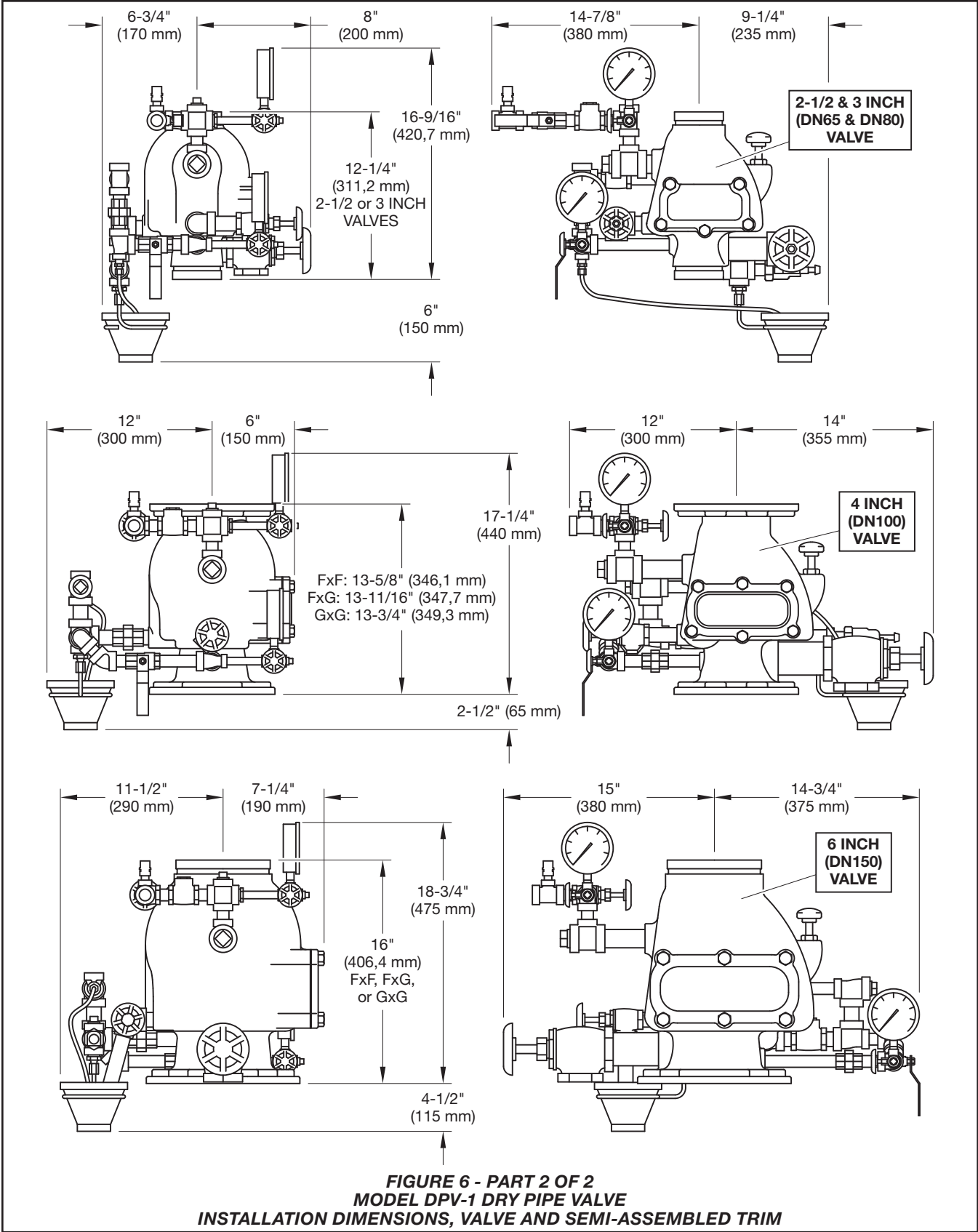

Care and Maintenance

The following procedures and inspections should be performed as indicated, in addition to any specific requirements of the NFPA, and any impairment must be immediately corrected.

Before closing a fire protection system main control valve for maintenance work on the fire protection system that it controls, permission to shut down the affected fire protection system must be obtained from the proper authorities and notify all personnel who may be affected by action.

The owner is responsible for the inspection, testing, and maintenance of their fire protection system and devices in compliance with this document, as well as with the applicable standards of the National Fire Protection Association (e.g., NFPA 25), in addition to the standards of any authority having jurisdiction. Contact the installing contractor or sprinkler manufacturer regarding any questions.

Automatic sprinkler systems are recommended to be inspected, tested, and maintained by a qualified Inspection Service in accordance with local requirements and/or national codes.

The operational test procedure and waterflow pressure alarm test procedure will result in operation of the associated alarms. Consequently, notification must first be given to the owner and the fire department, central station, or other signal station to which the alarms are connected.

Annual Operation Test Procedure

Note: Unless otherwise noted, refer to Figure 3, 4, or 5 to identify functional trim components.

Proper operation of the DPV-1 Valve (i.e., opening of the DPV-1 Valve during a fire condition) should be verified at least once a year as follows:

Step 1. If necessary, prevent water from flowing beyond the riser by:

- Close the Main Control Valve
- Open the Main Drain Valve
- Open the Main Control Valve one turn beyond the position at which water just begins to flow from the Main Drain Valve
- Close the Main Drain Valve

Step 2. Open the system Inspector's Test Connection.

Step 3. Verify that the DPV-1 Valve has operated, as indicated by the flow of water into the system and that all waterflow alarms operate properly.

Step 4. Close the system Main Control Valve.

Step 5. Reset the DPV-1 Valve in accordance with the Valve Setting Procedure.

Note: It is recommended that the requirement of NFPA 25 to annually inspect the inside of the valve be performed at this time and prior to resetting the DPV-1 Valve. Refer to the Automatic Drain Valve Inspection subsection Steps 2 through 5 for instructions with regard to the inspection of the Clapper Facing.

Quarterly Waterflow Alarm Test Procedure

Testing of the system waterflow alarms should be performed quarterly. To test the waterflow alarm, open the Alarm Test Valve, which will allow a flow of water to the Waterflow Pressure Alarm Switch and/or Water Motor Alarm. Upon satisfactory completion of the test, close the Alarm Test Valve.

Water Pressure Inspection

The Water Pressure Gauge is to be inspected monthly (per NFPA 25) to ensure that normal system water pressure is being maintained.

Air Pressure Inspection

The Air Pressure Gauge is to be inspected monthly (per NFPA 25) to ensure that normal system air pressure is being maintained.

Automatic Drain Valve Inspection

The Automatic Drain Valve should be inspected monthly (per NFPA 25) by depressing the plunger and checking to ensure that the Automatic Drain Valve is not discharging water and/or air. A discharge of water and/or air is an indication that the air and/or water seats are leaking, which could subsequently cause a false operation should the intermediate chamber become inadvertently pressurized.

If leakage is present, take the DPV-1 Valve out of service (i.e., close the main control valve, open the main drain valve, close the air supply control valve, remove the Dry Pipe Valve Accelerator from service, as applicable, in accordance with its Technical Data Sheet (Refer to TFP1105 for the VIZOR or TFP1112 for the ACC-1), and open the Inspector's Test Connection to relieve the system air pressure to 0 psig as indicated on the System Air Pressure

Nominal Valve Sizes Inches (DN)	Torque Feet Lbs. (Nm)
2-1/2 (DN65)	30 (41)
3 (DN80)	30 (41)
4 (DN100)	30 (41)
6 (DN150)	55 (75)

**TABLE C
HANDHOLE COVER BOLTS
MAXIMUM TORQUE**

Gauge), and then after removing the Handhole Cover, perform the following steps:

Step 1. Make sure that the Seat Ring is clean and free of any nicks or significant scratches.

Step 2. Remove the Clapper Assembly from the valve by first pulling out the Hinge Pin.

Step 3. Disassemble the Clapper Facing Retainer from the Clapper so that the Clapper Facing can be removed and inspected. Make sure that the Clapper Facing does not show signs of compression set, damage, etc. Replace the Clapper Facing if there is any signs of wear.

Step 4. Clean the Clapper Facing, Clapper, and Clapper Facing Retainer, and then reassemble the Clapper Assembly.

Step 5. Reinstall the Clapper Assembly with its Hinge Pin.

Step 6. Install Handhole Cover:

- a. Align Handhole Cover Gasket and Handhole Cover in proper orientation with valve body (Ref. Figure 1) and hold in place
- b. Apply LOCTITE No. 242 (or equivalent) to Hex Bolt threads
- c. Insert Hex Bolts through Handhole Cover Gasket and Handhole Cover, hand-tighten into valve body
- d. Using crossdraw sequence to assure uniformity, wrench-tighten Hex Bolts to appropriate torque values (Ref. Table C)
- e. Inspect to assure all Hex Bolts are securely tightened

Limited Warranty

For warranty terms and conditions, visit www.tyco-fire.com.

Ordering Procedure

Contact your local distributor for availability. When placing an order, indicate the full product name and Part Number (P/N).

Standard DPV-1 Dry Pipe Valve

ANSI standard outside diameter (O.D.) pipe size with grooved or ANSI drilled flange end connections and NPT threaded ports.

Specify: (specify size) Model DPV-1 Dry Pipe Valve with (specify) End Connections, P/N (specify):

Groove x Groove, ANSI 2.88 Inch (73,1 mm) O.D. Grooves:	
2-1/2 Inch (DN65) G x G	52-310-1-925
Groove x Groove, ANSI 3.50 Inch (88,9 mm) O.D. Grooves:	
3 Inch (DN80) G x G	52-310-1-930
Groove x Groove, ANSI 4.50 Inch (114,3 mm) O.D. Grooves:	
4 Inch (DN100) G x G	52-310-1-940
Flange x Groove, ANSI Flange x ANSI 4.50 Inch (114,3 mm) O.D. Groove:	
4 Inch (DN100) F x G	52-310-1-440
Flange x Flange, ANSI Flanges:	
4 Inch (DN100) F x F	52-310-1-040
Groove x Groove, ANSI 6.62 Inch (168,3 mm) O.D. Grooves:	
6 Inch (DN150) G x G	52-310-1-960
Flange x Groove, ANSI Flange x ANSI 6.62 Inch (168,3 mm) O.D. Groove:	
6 Inch (DN150) F x G	52-310-1-460
Flange x Flange, ANSI Flanges:	
6 Inch (DN150) F x F	52-310-1-060

Pre-Trimmed DPV-1 Assemblies with Butterfly Valve

Specify: 2-1/2 Inch DPV-1 Pre-Trimmed Valve Assembly, Grooved End Connections, P/N 52-310-3-925

Specify: 3 Inch DPV-1 Pre-Trimmed Valve Assembly, Grooved End Connections, P/N 52-310-3-930

Specify: 4 Inch DPV-1 Pre-Trimmed Valve Assembly, (specify) End Connection, P/N (specify):

Flange x Flange	52-310-3-040
Flange x Groove	52-310-3-440
Groove x Groove	52-310-3-940

Specify: 6 Inch DPV-1 Pre-Trimmed Valve Assembly, (specify) End Connection, P/N (specify):

Flange x Flange	52-310-3-060
Flange x Groove	52-310-3-460
Groove x Groove	52-310-3-960

Pre-Trimmed DPV-1 Assemblies without Butterfly Valve

Specify: 4 Inch DVP-1 Pre-Trimmed Valve Assembly without Butterfly, (specify) End Connection, P/N (specify):

Flange x Flange	52-310-4-040
Flange x Groove	52-310-4-440

Specify: 6 Inch DVP-1 Pre-Trimmed Valve Assembly without Butterfly, (specify) End Connection, P/N (specify):

Flange x Flange	52-310-4-060
Flange x Groove	52-310-4-460

Standard Galvanized Semi-Assembled DPV-1 Trim

Note: Valves with NPT threaded ports are intended for use with the Standard Galvanized Semi-Assembled DPV-1 Valve Trim described in Figures 3, 4 and 5 of this document.

Specify: 2-1/2 and 3 Inch DPV-1 Semi-Assembled Galvanized Trim, P/N 52-309-2-005

Specify: 4 Inch DPV-1 Semi-Assembled Galvanized Trim, P/N 52-309-2-001

Specify: 6 Inch DPV-1 Semi-Assembled Galvanized Trim, P/N 52-309-2-002

Optional Electronic Accelerator: VIZOR Electronic Dry Pipe Accelerator (with Trim)

(Ref. Technical Data Sheet TFP1105)

Specify: VIZOR Electronic Dry Pipe Accelerator for use with the 4 or 6 inch TYCO Model DPV-1 Dry Pipe Valve Trim, P/N 52-312-3-001

Optional Mechanical Accelerator: Model ACC-1 Dry Pipe Accelerator

(Ref. Technical Data Sheet TFP1112)

Specify: Model ACC-1 Dry Pipe Accelerator, P/N 52-311-1-001, and Galvanized Accelerator Trim for Model DPV-1 Dry Pipe Valve, P/N 52-311-2-010

Optional 600 PSI Water Pressure Gauge:

Specify: 600 PSI Water Pressure Gauge, P/N 92-343-1-004

Accessories

Refer to Technical data Sheets describing the following accessories, as applicable.

Specify: Description, P/N (specify):

Model PS10-2 Potter Electric Waterflow Pressure Alarm Switch	25710
(Ref. Potter Electric Technical Data Sheet)	
Model PS40-2 Potter Electric Low Air Pressure Alarm Switch	25730
(Ref. Potter Electric Technical Data Sheet)	
Model WMA-1 Water Motor Alarm	52-630-1-001
(Ref. Technical Data Sheet TFP921)	
Model AMD-1 Air Maintenance Device	52-324-2-002
(Ref. Technical Data Sheet TFP1221)	
Model AMD-2 Air Maintenance Device	52-326-2-001
(Ref. Technical Data Sheet TFP1231)	
Model AMD-3 Nitrogen Maintenance Device	52-328-2-001
(Ref. Technical Data Sheet TFP1241)	

Replacement Valve Parts

Specify: (description) for use with (specify size) Model DPV-1 Dry Pipe Valve, P/N (see Figure 1).

Replacement Trim Parts

Specify: (description) for use with (specify size) Model DPV-1 Dry Pipe Valve, P/N (see Figures 3, 4, or 5).

Other DPV-1 Dry Pipe Valves

Notes: Other DPV-1 Dry Pipe Valves are valves ordered with any combination of flange drilling, pipe groove outside diameter (O.D.), or port thread specification not offered as Standard DPV-1 Dry Pipe Valves.

Valves with NPT threaded ports are intended for use with the Standard Galvanized Semi-Assembled DPV-1 Valve Trim described in Figures 3, 4 and 5 of this document. Valves with ISO threaded ports are intended for use with special order trim that is provided by local distributors to meet the specific needs of certain localities. Please contact your local distributor regarding valves and valve trim for specific localities.

Specify: (specify size) Model DPV-1 Dry Pipe Valve with (specify) End Connections and (specify NPT or ISO) threaded ports, P/N (specify):

Other 2-1/2 Inch (DN65) Valves with NPT Threaded Ports

Groove x Groove, 3.00 Inch (76,1 mm) O.D.	
Grooves	52-309-1-930

Other 2-1/2 Inch (DN65) Valves with ISO Threaded Ports

Groove x Groove, ANSI 2.88 Inch (73,0 mm) O.D.	
Grooves	52-309-1-920
Groove x Groove, 3.00 Inch (76,1 mm) O.D.	
Grooves	52-309-1-940

Other 3 Inch (DN80) Valves with ISO Threaded Ports

Groove x Groove, ANSI 3.50 Inch (88,9 mm) O.D.	
Grooves	52-309-1-922

Other 4 Inch (DN100) Valves with NPT Threaded Ports

Flange x Groove, ISO Flange x ANSI 4.50 Inch (114,3 mm) O.D.	
Groove	52-309-1-253
Flange x Groove, AS Flange x ANSI 4.50 Inch (114,3 mm) O.D.	
Groove	52-309-1-613
Flange x Groove, JIS Flange x ANSI 4.50 Inch (114,3 mm) O.D.	
Groove	52-309-1-813
Flange x Flange, ISO Flanges	52-309-1-133
Flange x Flange, AS Flanges	52-309-1-513
Flange x Flange, JIS Flanges	52-309-1-713

Other 4 Inch (DN100) Valves with ISO Threaded Ports

Groove x Groove, ANSI 4.50 Inch (114,3 mm) O.D.	
Grooves	52-309-1-923
Flange x Groove, ISO Flange x ANSI 4.50 Inch (114,3 mm) O.D.	
Groove	52-309-1-213
Flange x Flange, ISO Flanges	52-309-1-113

Other 6 Inch (DN150) Valves with NPT Threaded Ports

Groove x Groove, 6.50 Inch (165,1 mm) O.D.	
Grooves	52-309-1-935
Flange x Groove, ANSI Flange x 6.50 Inch (165,1 mm) O.D.	
Groove	52-309-1-435
Flange x Groove, ISO Flange x ANSI 6.62 Inch (168,3 mm) O.D.	
Groove	52-309-1-255
Flange x Groove, ISO Flange x 6.50 Inch (165,1 mm) O.D.	
Groove	52-309-1-335
Flange x Groove, AS Flange x ANSI 6.62 Inch (168,3 mm) O.D.	
Groove	52-309-1-615
Flange x Groove, AS Flange x 6.50 Inch (165,1 mm) O.D.	
Groove	52-309-1-635
Flange x Groove, JIS Flange x ANSI 6.62 Inch (168,3 mm) O.D.	
Groove	52-309-1-815
Flange x Groove, JIS Flange x 6.50 Inch (165,1 mm) O.D.	
Groove	52-309-1-835
Flange x Flange, ISO Flanges	52-309-1-135
Flange x Flange, AS Flanges	52-309-1-515
Flange x Flange, JIS Flanges	52-309-1-715

Other 6 Inch (DN150) Valves with ISO Threaded Ports

Groove x Groove, ANSI 6.62 Inch (168,3 mm) O.D.	
Grooves	52-309-1-925
Groove x Groove, 6.50 Inch (165,1 mm) O.D.	
Grooves	52-309-1-945
Flange x Groove, ISO Flange x ANSI 6.62 Inch (168,3 mm) O.D.	
Groove	52-309-1-215
Flange x Groove, ISO Flange x 6.50 Inch (165,1 mm) O.D.	
Groove	52-309-1-315
Flange x Flange, ISO Flanges	52-309-1-115

FireLock® Butterfly Valve

Series 705 with Weatherproof Actuator



1.0 PRODUCT DESCRIPTION

- Available Sizes: 2 – 12”/50 – 300 mm
- cULus Listed, LPCB Listed, FM and VdS Approved for service up to 300 psi/2068 kPa /20 bar.
- Designed for fire protection services only.
- Features a weatherproof actuator housing Approved for indoor and outdoor use.
- Actuation options: Hand wheel (2 – 12”/50 – 300 mm)
- Exclusively for use with pipe and Victaulic products which feature ends formed with the Victaulic Original Groove System (OGS) groove profile (see section 7.0 for Reference Materials).

2.0 CERTIFICATION/LISTINGS



NOTES

- Refer to Victaulic [submittal publication 10.01](#) for details

ALWAYS REFER TO ANY NOTIFICATIONS AT THE END OF THIS DOCUMENT REGARDING PRODUCT INSTALLATION, MAINTENANCE OR SUPPORT.

System No.		Location	
Submitted By		Date	

Spec Section		Paragraph	
Approved		Date	

2.1 CERTIFICATION/LISTINGS

Size	Approval/Listing Service Pressures			
	Series 705 Butterfly Valve			
	cULus	FM	Vds	LPCB
2 50	up to 300psi/2068kPa	n/a	up to 300psi/2068kPa	up to 300psi/2068kPa
2½ 65	up to 300psi/2068kPa	up to 300psi/2068kPa	n/a	up to 300psi/2068kPa
76.1 mm	up to 300psi/2068kPa	up to 300psi/2068kPa	up to 300psi/2068kPa	up to 300psi/2068kPa
3 80	up to 300psi/2068kPa	up to 300psi/2068kPa	up to 300psi/2068kPa	up to 300psi/2068kPa
4 100	up to 300psi/2068kPa	up to 300psi/2068kPa	up to 300psi/2068kPa	up to 300psi/2068kPa
5 125	up to 300psi/2068kPa	up to 300psi/2068kPa	n/a	up to 300psi/2068kPa
139.7 mm	up to 300psi/2068kPa	up to 300psi/2068kPa	up to 300psi/2068kPa	up to 300psi/2068kPa
6 150	up to 300psi/2068kPa	up to 300psi/2068kPa	up to 300psi/2068kPa	up to 300psi/2068kPa
165.1 mm	up to 300psi/2068kPa	up to 300psi/2068kPa	n/a	up to 300psi/2068kPa
8 200	up to 300psi/2068kPa	up to 300psi/2068kPa	up to 300psi/2068kPa	up to 300psi/2068kPa
10 250	up to 300psi/2068kPa	up to 300psi/2068kPa	n/a	up to 300psi/2068kPa
12 300	up to 300psi/2068kPa	up to 300psi/2068kPa	n/a	up to 300psi/2068kPa

3.0 SPECIFICATIONS – MATERIAL

Body: Ductile Iron conforming to ASTM A-536, Grade 65-45-12

End Face, 2 – 6”/50 – 150 mm: Ductile Iron conforming to ASTM A-536, Grade 65-45-12

Seal Retainer, 8 – 12”/200 – 300 mm: Ductile Iron conforming to ASTM A-536, Grade 65-45-12

Body Coating: Black alkyd enamel

Disc: Ductile Iron conforming to ASTM A-536, Grade 65-45-12, with electroless nickel coating conforming to ASTM B-733

Seat: Grade “E” EPDM

Stems: 416 stainless steel conforming to ASTM A-582

Stem Seal Cartridge: C36000 brass

Bearings: Stainless steel with TFE lining

Stem Seals: EPDM

Stem Retaining Ring: Carbon steel

Actuator:

2 – 8”/50 – 200 mm: Brass or bronze traveling nut on a steel lead screw, in a ductile iron housing

10 – 12”/250 – 300 mm: Steel worm and cast iron quadrant gear, in a cast iron housing

4.0 DIMENSIONS

Series 705

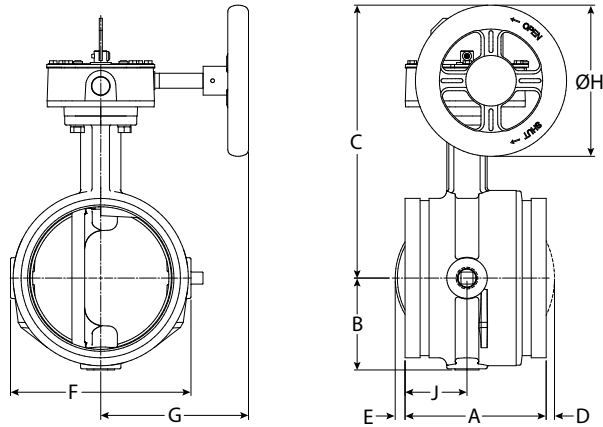

Size		Dimensions								
Nominal inches mm	Actual Outside Diameter inches mm	E to E A inches mm	B inches mm	C inches mm	D inches mm	E inches mm	F inches mm	G inches mm	DIA H inches mm	J inches mm
2 60.3	2.375 60.3	4.25 108.0	2.28 57.9	6.41 162.8	-	-	4.00 101.6	4.22 107.2	4.50 114.3	2.12 53.8
2½ 73	2.875 73.0	3.77 95.8	2.28 57.9	7.54 191.5	-	-	4.00 101.6	4.22 107.2	4.50 114.3	1.77 45.0
76.1 mm	3.000 76.1	3.77 95.8	2.28 57.9	7.54 191.5	-	-	4.00 101.6	4.22 107.2	4.50 114.3	1.77 45.0
3 88.9	3.500 88.9	3.77 95.8	2.53 64.3	7.79 197.9	-	-	4.50 114.3	4.22 107.2	4.50 114.3	1.77 45.0
108 mm	4.250 108.0	4.63 117.6	2.88 73.2	8.81 223.8	-	-	5.50 139.7	4.22 107.2	4.50 114.3	2.20 55.9
4 114.3	4.500 114.3	4.63 117.6	2.88 73.2	8.81 223.8	-	-	5.50 139.7	4.22 107.2	4.50 114.3	2.20 55.9
133 mm	5.250 133.0	5.88 149.4	3.35 85.1	10.88 276.4	-	-	6.56 166.6	6.19 157.2	6.30 160.0	2.58 65.5
139.7 mm	5.500 139.7	5.88 149.4	3.35 85.1	10.88 276.4	-	-	6.56 166.6	6.19 157.2	6.30 160.0	2.58 65.6
5 141.3	5.563 141.3	5.88 149.4	3.35 85.1	10.88 276.4	-	-	6.56 166.6	6.19 157.2	6.30 160.0	2.58 65.5
159 mm	6.250 159.0	5.88 149.4	3.84 97.5	11.38 289.1	-	0.41 10.4	7.52 191.0	6.19 157.2	6.30 160.0	2.58 65.5
165.1 mm	6.500 165.1	5.88 149.4	3.84 97.5	11.38 289.1	-	0.41 10.4	7.52 191.0	6.19 157.2	6.30 160.0	2.58 65.5
6 168.3	6.625 168.3	5.88 149.4	3.84 97.5	11.38 289.1	-	0.41 10.4	7.52 191.0	6.19 157.2	6.30 160.0	1.90 48.3
8 219.1	8.625 219.1	5.33 135.4	5.07 128.8	13.53 343.6	0.80 20.3	1.47 37.3	10.00 254.0	6.19 157.2	8.10 205.7	2.33 59.2
10 273	10.750 273.0	6.40 162.6	6.37 161.8	15.64 397.3	1.41 35.8	1.81 46.0	12.25 311.2	8.10 205.7	9.00 228.6	-
12 323.9	12.750 323.9	6.50 165.1	7.36 186.9	16.64 422.7	2.30 58.4	2.80 71.1	14.25 362.0	8.10 205.7	9.00 228.6	-

NOTE

- Optional ½"/15 mm tap available. Contact Victaulic for details.

5.0 PERFORMANCE

Series 705

The chart expresses the frictional resistance of Victaulic Series 705 Butterfly Valve in equivalent feet/meters of straight pipe.

Nominal Size mm inches	Outside Diameter mm inches	Equivalent
		Feet/m of pipe
2 50	2.375 60.3	6 1.8
2½ 65	2.875 73.0	6 1.8
76.1 mm	3.000 76.1	6 1.8
3 80	3.500 88.9	7 2.1
4 100	4.500 114.3	8 2.4
108 mm	108 mm	8 2.4
5 125	5.563 141.3	12 3.7
133 mm	133 mm	12 3.7
139.7 mm	5.500 139.7	12 3.7
6 150	6.625 168.3	14 4.2
159 mm	159 mm	14 4.3
165.1 mm	6.500 165.1	14 4.2
8 200	8.625 219.1	16 4.9
10 250	10.750 273.0	18 5.5
12 300	12.750 323.9	19 5.8

5.1 PERFORMANCE

Series 705

C_v values for flow of water at +60°F/+16°C through a fully open valve are shown in the table below. For additional details, contact Victaulic.

Formulas for C_v values

$$\Delta P = \frac{Q^2}{C_v^2}$$

$$Q = C_v \times \sqrt{\Delta P}$$

Where:

Q = Flow (GPM)
 ΔP = Pressure Drop (psi)
 C_v = Flow Coefficient

Formulas for K_v values

$$\Delta P = \frac{Q^2}{K_v^2}$$

$$Q = K_v \times \sqrt{\Delta P}$$

Where:

Q = Flow (m³/hr)
 ΔP = Pressure Drop (Bar)
 K_v = Flow Coefficient

Valve Size		Full Open
Nominal Size inches mm	Actual Outside Diameter inches mm	Flow Coefficient C_v
2 50	2.375 60.3	170
2½ 65	2.875 73.0	260
76.1 mm	3.000 76.1	260
3 80	3.500 88.9	440
4 100	4.500 114.3	820
108 mm	108 mm	820
5 125	5.563 141.3	1200
133 mm	133 mm	1200
139.7 mm	5.500 139.7	1200
6 150	6.625 168.3	1800
159 mm	159 mm	1800
165.1 mm	6.500 165.1	1800
8 200	8.625 219.1	3400
10 250	10.750 273.0	5800
12 300	12.750 323.9	9000

Valve Size		Full Open
Nominal Size inches mm	Actual Outside Diameter inches mm	Flow Coefficient K_v
2 50	2.375 60.3	147
2½ 65	2.875 73.0	225
76.1 mm	3.000 76.1	225
3 80	3.500 88.9	380
4 100	4.500 114.3	710
108 mm	108 mm	710
5 125	5.563 141.3	1040
133 mm	133 mm	1040
139.7 mm	5.500 139.7	1040
6 150	6.625 168.3	1560
159 mm	159 mm	1560
165.1 mm	6.500 165.1	1560
8 200	8.625 219.1	2940
10 250	10.750 273.0	5020
12 300	12.750 323.9	7790

6.0 NOTIFICATIONS

WARNING



- Read and understand all instructions before attempting to install, remove, adjust, or maintain any Victaulic piping products.
- Depressurize and drain the piping system before attempting to install, remove, adjust, or maintain any Victaulic piping products.
- Wear safety glasses, hardhat, and foot protection.

Failure to follow these instructions could result in death or serious personal injury and property damage.

7.0 REFERENCE MATERIALS

Switch and Wiring

1. The supervisory switch contains two single pole, double throw, pre-wired switches.
2. Switches are rated:
10 amps @ 125 or 250 VAC/60 Hz
0.50 amps @ 125 VDC
0.25 amps @ 250 VDC
3. Switches supervise the valve in the “OPEN” position.
5. One switch has two #18 insulated wires per terminal, which permit complete supervision of leads (refer to diagrams and notes below). The second switch has one #18 insulated wire per terminal. This double circuit provides flexibility to operate two electrical devices at separate locations, such as an indicating light and an audible alarm, in the area that the valve is installed.
6. A #14 insulated ground lead (green) is provided.

Switch #1 = S1

For connection to the supervisory circuit of a UL Listed alarm control panel

Switch #2 = S2

Auxiliary switch that may be connected to auxiliary devices, per the authority having jurisdiction

S1 { Normally Closed: (2) Blue
Common: (2) Yellow

S2 { Normally Closed: Blue with Orange Stripe
Normally Open: Brown with Orange Stripe
Common: Yellow with Orange Stripe

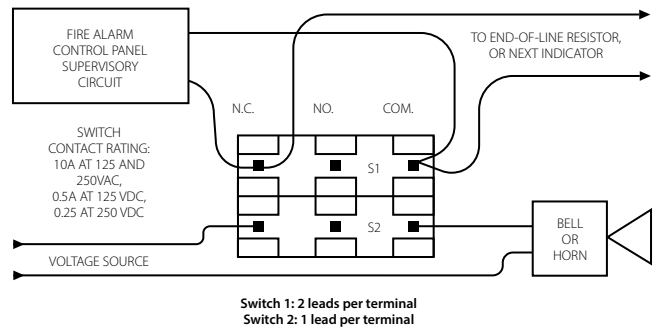
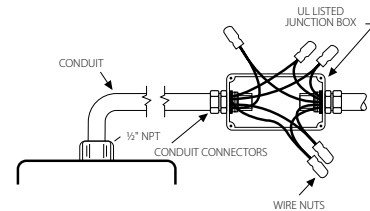

NOTES

- The above diagram shows a connection between the common terminal (yellow – S1 and yellow-with-orange stripe – S2) and the normally closed terminal (blue – S1 and blue-with-orange stripe – S2). In this example, the indicator light and alarm will stay on until the valve is fully open. When the valve is fully open, the indicator light and alarm will go out. Cap off any unused wires (e.g. brown with orange stripe).
- Only S1 (two leads per terminal) may be connected to the fire alarm control panel.
- The connection of the alarm switch wiring shall be in accordance with NFPA 72 and the auxiliary switch per NFPA 70 (NEC).

7.1 REFERENCE MATERIALS

[10.01: Regulatory Approval Reference Guide](#)

[29.01: Terms and Conditions/Warranty](#)

[I-100: Field Installation Handbook](#)

User Responsibility for Product Selection and Suitability

Each user bears final responsibility for making a determination as to the suitability of Victaulic products for a particular end-use application, in accordance with industry standards and project specifications, and the applicable building codes and related regulations as well as Victaulic performance, maintenance, safety, and warning instructions. Nothing in this or any other document, nor any verbal recommendation, advice, or opinion from any Victaulic employee, shall be deemed to alter, vary, supersede, or waive any provision of Victaulic Company's standard conditions of sale, installation guide, or this disclaimer.

Intellectual Property Rights

No statement contained herein concerning a possible or suggested use of any material, product, service, or design is intended, or should be construed, to grant any license under any patent or other intellectual property right of Victaulic or any of its subsidiaries or affiliates covering such use or design, or as a recommendation for the use of such material, product, service, or design in the infringement of any patent or other intellectual property right. The terms "Patented" or "Patent Pending" refer to design or utility patents or patent applications for articles and/or methods of use in the United States and/or other countries.

Note

This product shall be manufactured by Victaulic or to Victaulic specifications. All products to be installed in accordance with current Victaulic installation/assembly instructions. Victaulic reserves the right to change product specifications, designs and standard equipment without notice and without incurring obligations.

Installation

Reference should always be made to the Victaulic installation handbook or installation instructions of the product you are installing. Handbooks are included with each shipment of Victaulic products, providing complete installation and assembly data, and are available in PDF format on our website at www.victaulic.com.

Warranty

Refer to the Warranty section of the current Price List or contact Victaulic for details.

Trademarks

Victaulic and all other Victaulic marks are the trademarks or registered trademarks of Victaulic Company, and/or its affiliated entities, in the U.S. and/or other countries.